

RETURN BIDS TO:
RETOURNER LES SOUMISSIONS À:
PWGSC/TPSGC Acquisitions
1045 Main Street
1st Floor, Lobby C
Unit 108
Moncton, NB E1C 1H1
Bid Fax: (506) 851-6759

SOLICITATION AMENDMENT
MODIFICATION DE L'INVITATION

The referenced document is hereby revised; unless otherwise indicated, all other terms and conditions of the Solicitation remain the same.

Ce document est par la présente révisé; sauf indication contraire, les modalités de l'invitation demeurent les mêmes.

Comments - Commentaires

This bid solicitation cancels and supersedes previous bid solicitation number W3557-120024/A dated February 21, 2012 with a closing of March 8, 2012 at 02:00 PM Atlantic Standard Time.

This procurement is subject to the Nunavut Land Claims Agreement.

Vendor/Firm Name and Address
Raison sociale et adresse du fournisseur/de l'entrepreneur

Issuing Office - Bureau de distribution

NB / PEI Division - Moncton Acquisitions Office
1045 Main Street
1st Floor, Lobby C
Unit 108
Moncton, NB E1C 1H1

Title - Sujet Fuel Tank and Components	
Solicitation No. - N° de l'invitation W3557-120024/B	Amendment No. - N° modif. 005
Client Reference No. - N° de référence du client W3557-120024	Date 2012-04-24
GETS Reference No. - N° de référence de SEAG PW-\$MCT-014-4434	
File No. - N° de dossier MCT-1-34452 (014)	CCC No./N° CCC - FMS No./N° VME
Solicitation Closes - L'invitation prend fin at - à 02:00 PM on - le 2012-05-07	Time Zone Fuseau horaire Atlantic Daylight Saving Time ADT
F.O.B. - F.A.B. Plant-Usine: <input type="checkbox"/> Destination: <input checked="" type="checkbox"/> Other-Autre: <input type="checkbox"/>	
Address Enquiries to: - Adresser toutes questions à: MacDonald, Charline	Buyer Id - Id de l'acheteur mct014
Telephone No. - N° de téléphone (506) 851-6067 ()	FAX No. - N° de FAX (506) 851-6759
Destination - of Goods, Services, and Construction: Destination - des biens, services et construction:	

Instructions: See Herein

Instructions: Voir aux présentes

Delivery Required - Livraison exigée	Delivery Offered - Livraison proposée
Vendor/Firm Name and Address Raison sociale et adresse du fournisseur/de l'entrepreneur	
Telephone No. - N° de téléphone Facsimile No. - N° de télécopieur	
Name and title of person authorized to sign on behalf of Vendor/Firm (type or print) Nom et titre de la personne autorisée à signer au nom du fournisseur/de l'entrepreneur (taper ou écrire en caractères d'imprimerie)	
Signature	Date

Solicitation No. - N° de l'invitation

W3557-120024/B

Client Ref. No. - N° de réf. du client

W3557-120024

Amd. No. - N° de la modif.

005

File No. - N° du dossier

MCT-1-34452

Buyer ID - Id de l'acheteur

mct014

CCC No./N° CCC - FMS No/ N° VME

****Please Note: Same as Solicitation Amendment No. 003 and 004 as they did not transmit properly****

Title: Fuel Tank and Components

Solicitation Amendment No. 005

This solicitation is hereby amended to provide the following questions and answers:

Q6. I am inquiring about solicitation No. W3557-120024/B – Fuel Tank and Components with regards to the stairs and platform. I was wondering if a ladder and platform system would be sufficient as the company I am speaking to states a ladder and platform system is more appropriate and safety oriented due to the style and height of the tank. I have attached a drawing at ANNEX “C” of the tank for reference. Would this type of ladder and platform system be acceptable?

A6. No, a stair is required, not a ladder and it must adhere to safety regulations. Please refer to attached ANNEX “D”, however a hand rail might be required.

If your bid has already been forwarded and you wish to revise same, this revision should be sent either in a sealed envelope and mailed to the above address or by facsimile (506) 851-6759 and reach the undersigned before the appropriate closing date. The solicitation number and the closing date are to be shown on the outside of the sealed envelope or on the facsimile transmission.

All other terms and conditions of the solicitation document remain unchanged.

All enquiries concerning this amendment are to be forwarded to:

Name: Charline MacDonald
Telephone No.: (506) 851-6067
Facsimile No: (506) 851-6759

ANNEX(E) "C"

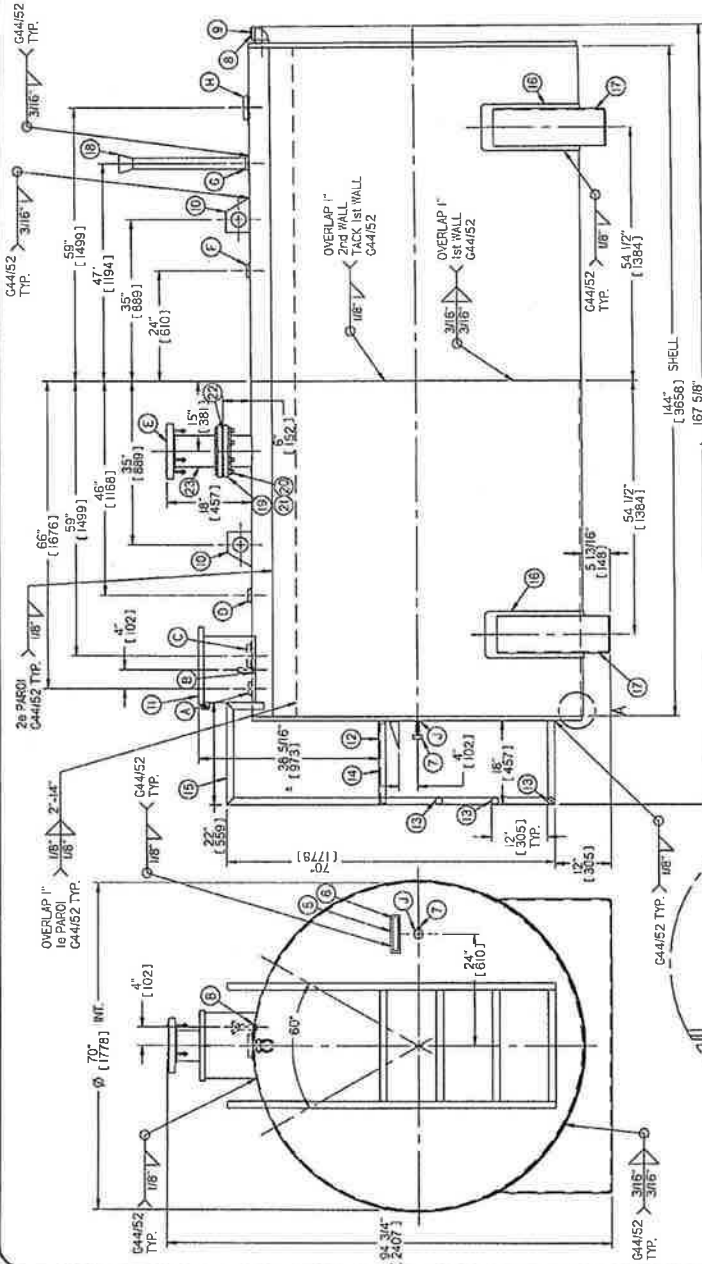

DESIGN EMIS. POUR FABRICATION
2010-04-06
PROD #1 _____ AQ #1
BUREAU _____ AQ #2
PREPARATION _____ ACHAT #1
MAGASIN _____ ACHAT #2
PEINTURE _____ DOSSIER

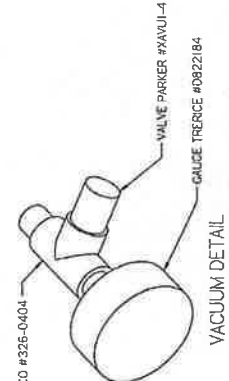
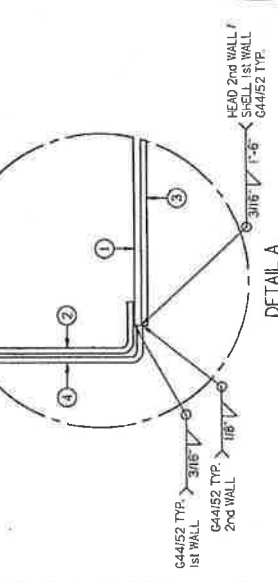
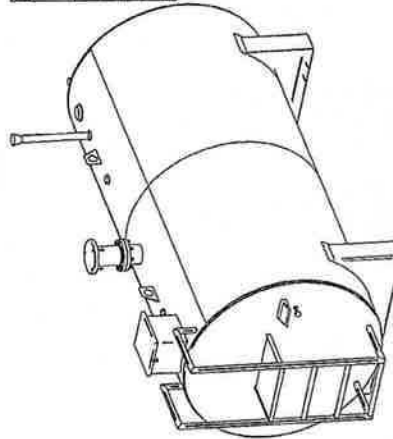

No	QTY	DIA	TYPE	CL	MAT.	LIST OF OPENINGS		SCH	NOTE
						MAT. PFE	LENG. PIPE		
A	1	2"	WTF	250	SA105	-	-	-	DIP
B	1	3/4"	HALF CFLG	150	SA105	-	-	-	DRINK SB
C	1	4"	WTF	250	SA105	-	-	-	FLL
D	1	2"	WTF	250	SA105	-	-	-	GAUGE
E	1	6"	SHOE FLANGE	150	SA105	-	-	-	EMERGE VENT
F	1	2"	WTF	250	SA105	-	-	-	RETURN
G	1	2"	WTF	250	SA105	-	-	-	WEAT
H	1	4"	WTF	250	SA105	-	-	-	SUCTION
J	1	1/4"	WTF	250	SA105	-	-	-	VACUUM

Item	Qty	Description	Thk (in)	Width (in)	Length (in)	Weight (lb)	Material
1	2	SHELL 1ST WALL 4.0mm	0.187	72.000	221739	1695	A101I
2	2	FLANGED HEAD 70"OD X 4.0mm - 8 GA	0.158			366	A101I
3	2	PLATE 2ND WALL 3.0mm	0.125	72.000	185523	945	A101I
4	2	FLANGED HEAD 70"OD X 4.0mm - 8 GA	0.158			364	A101I
5	1	ULC NAMEPLATE BRACKET				0	Copper
6	1	ULC NAMEPLATE				0	Copper
7	1	VACUUM KIT				1	
8	1	S/W ELBOW 90deg. 2 dig				0	SA-105
9	1	INTERSTICE PLUG				0	URETHANE
10	2	LIFTING LUG 6mm TYPE 1	0.250			3	A101I
11	1	RECT. SPILL BOX 14" X 14"				35	
12	1	ANGLE 1/8" X 1 1/2" X 1 1/2" X 60" LG TOTAL					C4021-44W
13	3	RUNGS 1.5"Ø "SAFETY TRENDS"			24.000	12	AMICO
14	1	GRATING 3/16" X 1" TYPE 19-4	1.000	17.000	23.000	111	ISALV.
15	1	TUBING 1SS 1/8" X 1/2" X 20'-0" TOTAL	0.187	10.000	81.918	87	A101I
16	2	WEAR PLATE	0.313	31.702	77.924	270	A101I
17	2	FOLDED SADDLE				9	SALV.
18	1	NORMAL VENT 2" DIA X 60" LG - V-VENT BAYCO #417-48				34	SA-105
19	2	FLANGE SORF 6" DIA 150#				5	GRU
20	8	HEX BOLT 3/4"-10NC X 3 1/2" LG				1	GRU
21	8	HEX NUT 3/4"-10NC				1	GRU
22	1	RING GASKET FOR FLANGE 6" DIA 150#				1	CARLOCK
23	1	PIPE 6" DIA SCH 40			11.900	18	SAS39

DIP STICK - VOLUMETRIC CHART

GENERAL NOTES

BUILT AS PER ULC-5601 LAST EDITION
 PRELIMINARY TEST 29 @ 43 PSIG @ 30 KPa
 INSIDE FINISH NONE
 OUTSIDE FINISH SSSC-SP6 - 1 COAT WHITE EPOXY AMERLOCK 2
 14-8mils DFT 325 sqft
 EMERGENCY VENT CAPACITY: 109 cume. / min
 REAL CAPACITY: 2018 IG 19176 L / 7424 USG.

NO	DATE	REVISION	BY	APPROV

NO	DATE	REVISION	BY	APPROV

NO	DATE	REVISION	BY	APPROV

TOTAL WEIGHT
4043 lbm

IX ABOVEGROUND TANK 2000 IG
300" DOUBLE WALL

CUSTOMER: _____
 PURCHASE ORDER NO: _____
 PROJECT: _____

REV: 0

