

# EQPT DETAIL - 1

COMMERCIAL KITCHEN HOODS Section 23 38 13  
Page 1  
2012-08-10

---

## PART 1 - GENERAL

- 1.1 RELATED SECTIONS
- .1 Section 01 33 00 - Submittal Procedures.
  - .2 Section 01 61 00 - Common Product Requirements.
  - .3 Section 01 74 20 - Construction/Demolition Waste Management and Disposal.
  - .4 Section 01 78 00 - Closeout Submittals.
- 1.2 REFERENCES
- .1 Definitions:
    - .1 Certified Ratings: catalogued or published ratings obtained from tests carried out by manufacturer or independent testing agency designated by manufacturer and signifying adherence to codes and standards.
  - .2 Reference Standards:
    - .1 Canadian Standards Association (CSA International)
    - .2 National Fire Protection Association (NFPA)
      - .1 NFPA 96-2011, Standard for Ventilation Control and Fire Protection of Commercial Cooking Operations, 2008 Edition.
    - .3 Underwriter's Laboratories of Canada (ULC)
- 1.3 ACTION AND INFORMATIONAL SUBMITTALS
- .1 Provide submittals in accordance with Section 01 33 00.
  - .2 Product Data:
    - .1 Provide manufacturer's printed product literature and datasheets for hood, grease filter, and grease extractor, and include product characteristics, performance criteria, physical size, finish and limitations.
  - .3 Shop Drawings:
    - .1 Provide drawings stamped and signed by professional engineer registered or licensed in Province of Ontario, Canada.
-



- 2.3 GREASE EXTRACTOR TYPE (Cont'd)
- .3 Fire detection and suppression system: in accordance with NFPA 96.
  - .4 Control system:
    - .1 Automatic demand control ventilation system complete with motorized dampers (one per hood); IR sensors, control panel capable of calculating the flow requirement and controlling the associated exhaust fan.
  - .5 Cleaning system:
    - .1 Nozzle type detergent spray cleaning system.
    - .2 System to conform to Sanitary Standards of Food and Beverage Industry 3A and USPHS standards.
  - .6 Performance: as indicated on drawings.
    - .1 Pressure drop max through unit up to duct collar: as per drawings.
  - .7 Controls for hoods by Halton as part of hood package.

PART 3 - EXECUTION

- 3.1 APPLICATION
- .1 Manufacturer's Instructions: comply with manufacturer's written recommendations, including product technical bulletins, handling, storage and installation instructions, and datasheets.
- 3.2 INSTALLATION
- .1 Install hoods in accordance with manufacturers instructions.
  - .2 Install filter/filter media prior to acceptance.
- 3.3 CLEANING
- .1 Clean in accordance with Section 01 74 11.
    - .1 Remove surplus materials, excess materials, rubbish, tools and equipment.
  - .2 Waste Management: separate waste materials for reuse and recycling in accordance with Section 01 74 20.

HOOD INFORMATION TABLE													
DIM. UNITS NUMBER	HOOD MODEL	EXHAUST AIR PRESSURE	EXHAUST AIR FLOW REQUIREMENTS			GREASE EXTRACTOR			HOOD CONSTRUCTION	HOOD WEIGHT			
			T.A.B. PORT STATIC PRESSURE	TOTAL HOOD STATIC PRESSURE	QTY	EXHAUST COLLAR LENGTH	EXHAUST COLLAR WIDTH	SIZE L			SIZE H	TYPE	
MPE/AL UNITS	1-1	K/E	.308 "WG	.428 "WG	2	12"	10"	8	20"	13"	KSA	ALL 18GA. 304 S.S.	1175lb
METRIC UNITS	1-1	K/E	1411 1/8	.076 kPa	2	305 mm	254 mm	0	508	330	KSA	ALL 18GA. 304 S.S.	534 kg

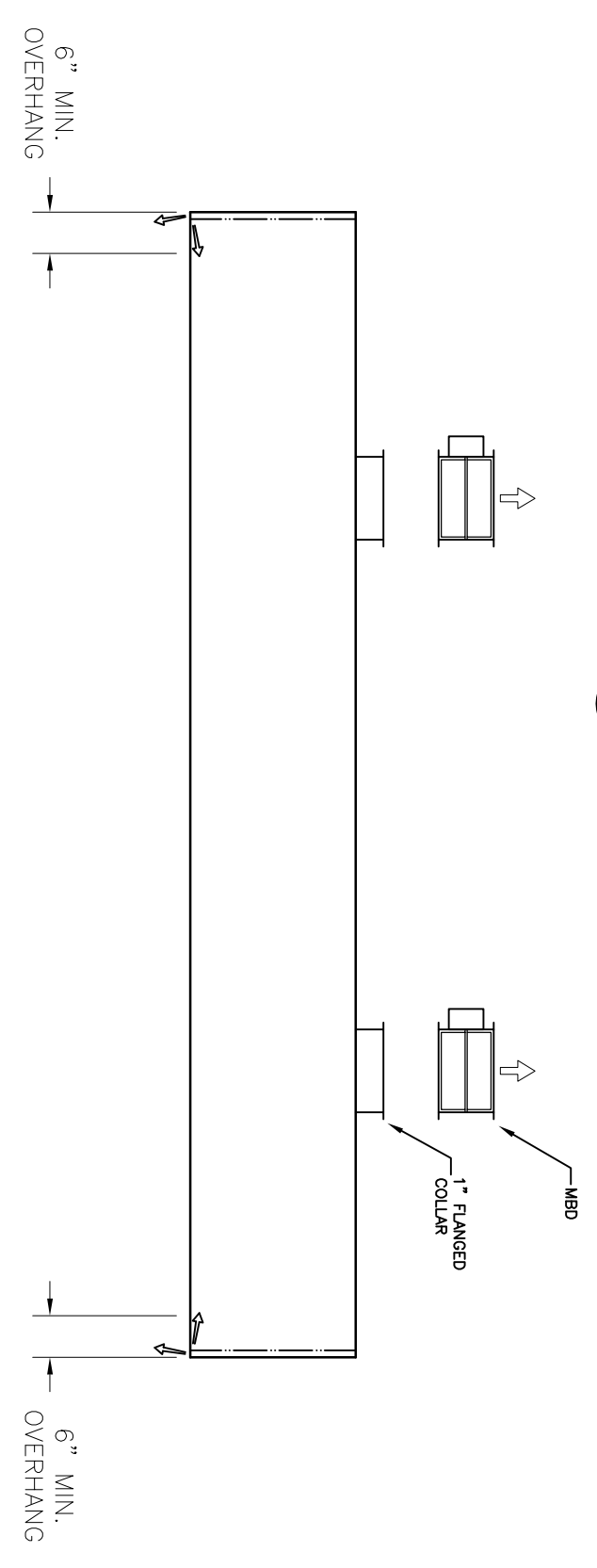
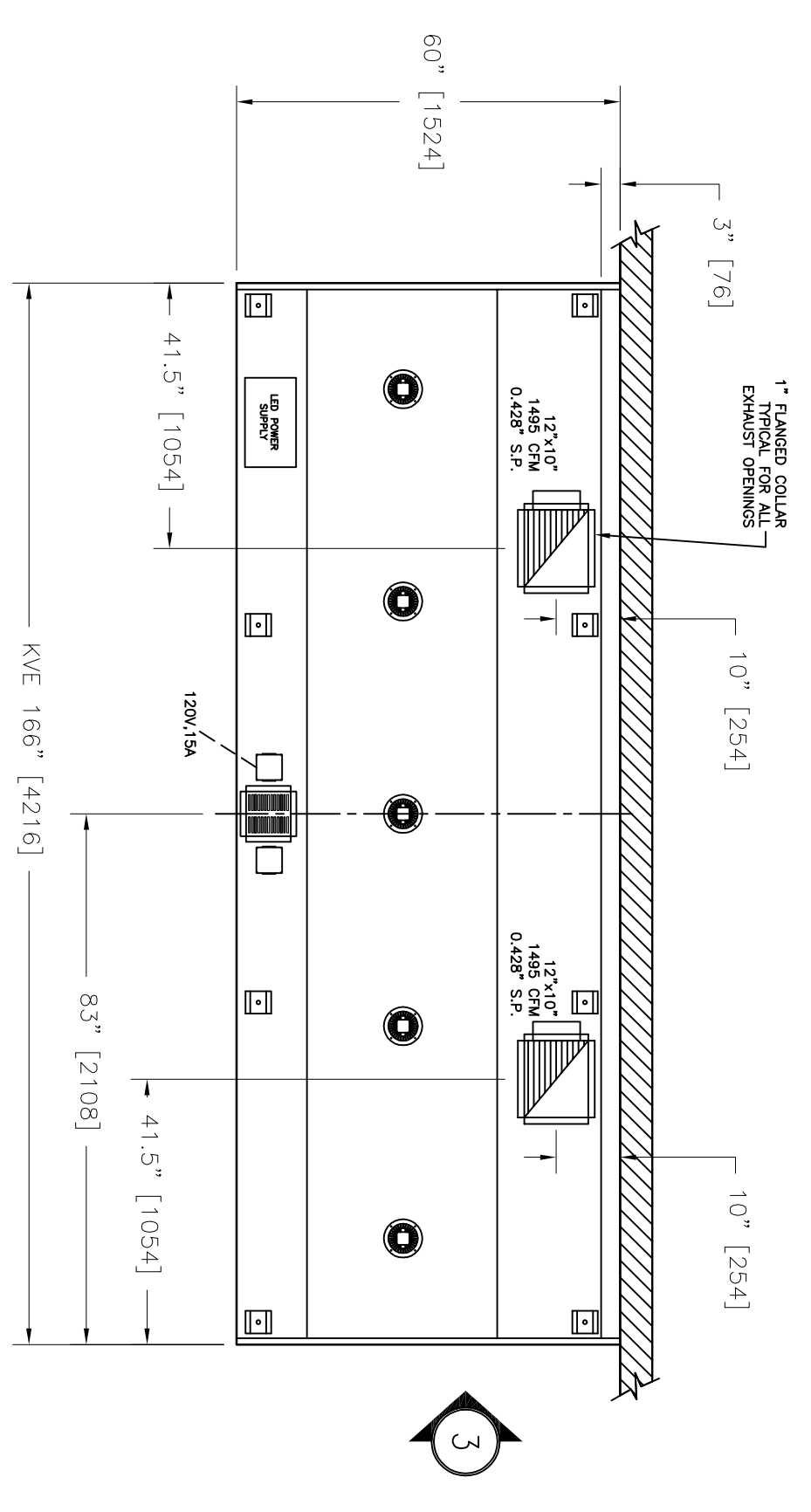

ITEM # 1-1  
ELEVATION VIEW

ITEM # 1-1  
SECTION VIEW

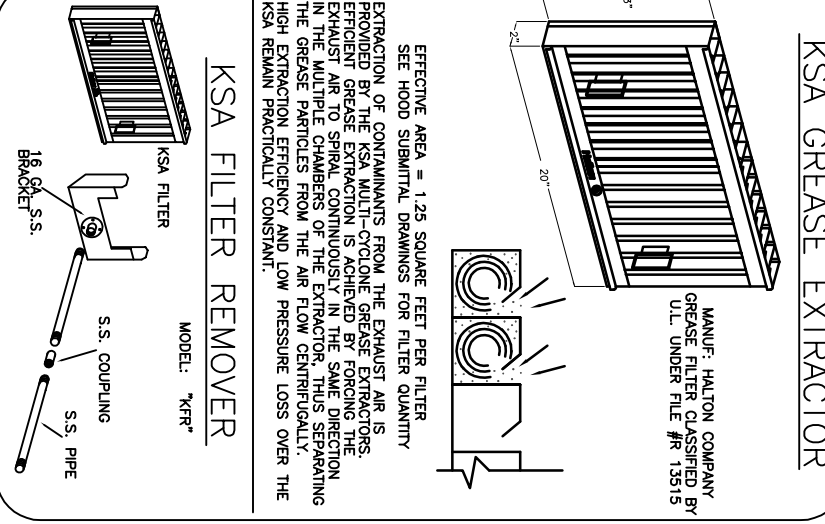
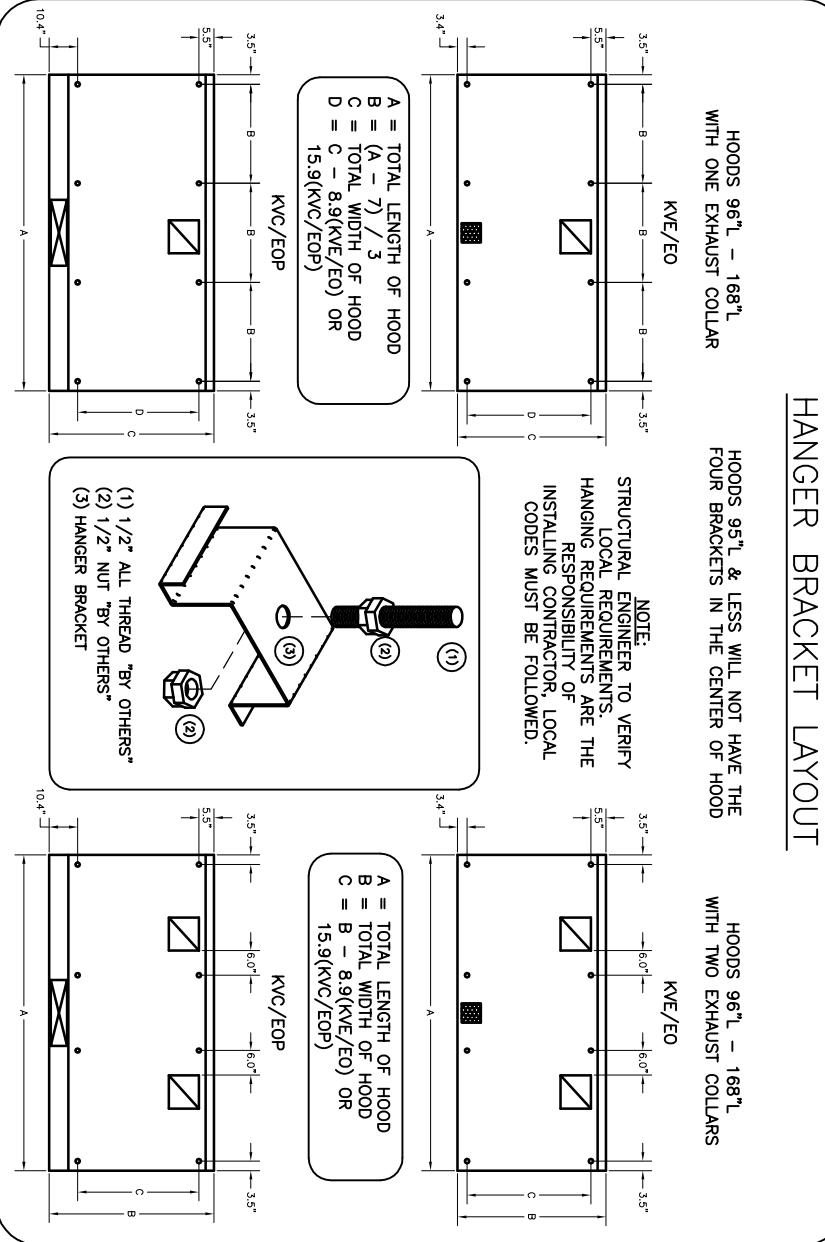
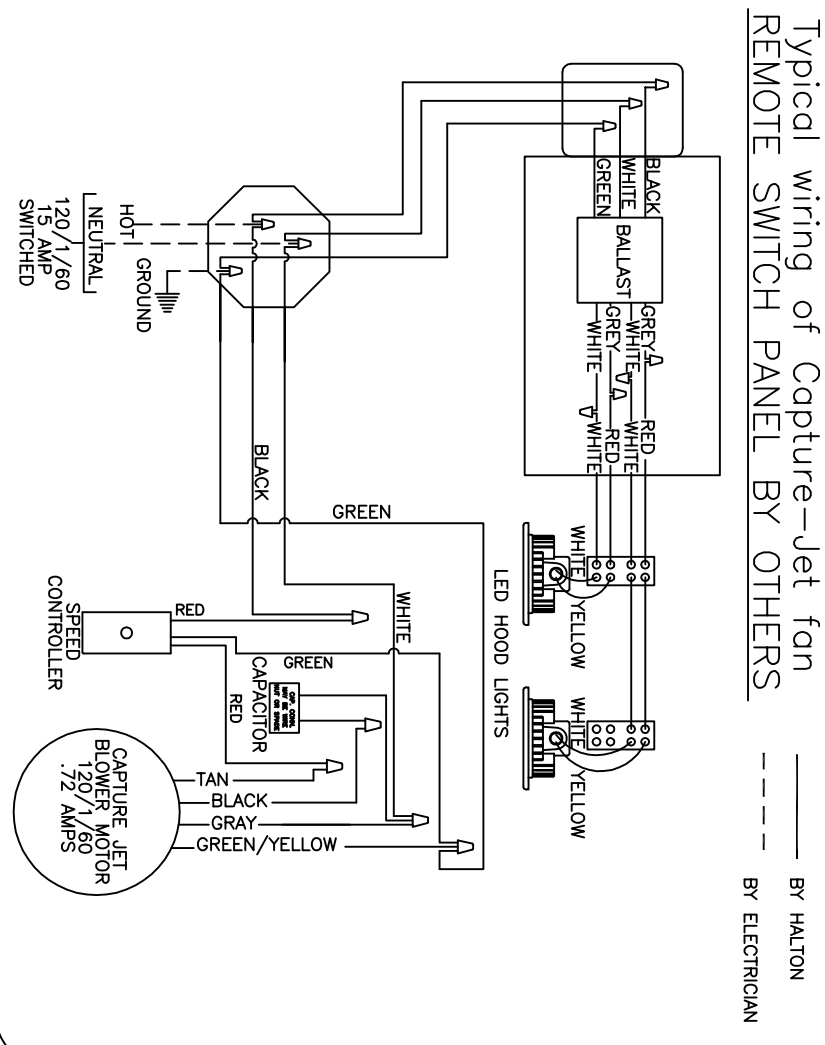
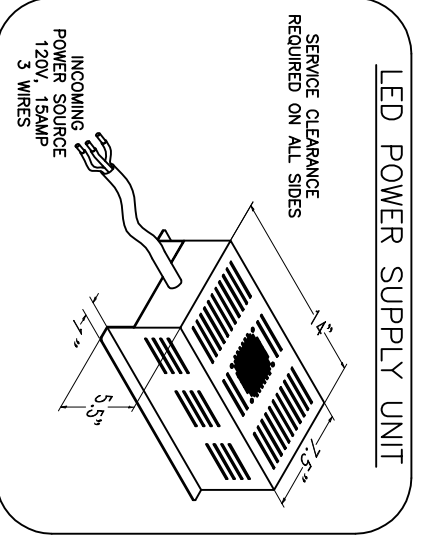

**PERFORMANCE CRITERIA**  
 MANUFACTURER MUST PROVIDE A WRITTEN GUARANTEE OF PERFORMANCE, ENSURING THE SPECIFIC PERFORMANCE OF THE HOOD SHALL BE AS SPECIFIED IN THE ENGINEER'S SATISFACTION WHEN INSTALLED AND BALANCED ACCORDING TO DESIGN AIR FLOW AND CAPTURE VELOCITY. THE DESIGN AIR FLOW SHALL BE DETERMINED BY TAG POINTS AND PRESSURE VS. AIR FLOW CURVES. ANY ALTERNATE SYSTEM MUST MEET THE DESIGN AIR FLOW AND CAPTURE VELOCITY REQUIREMENTS. THE THRESHOLD FLOW RATE DETERMINED AT THE DESIGN AIR FLOW AND CAPTURE VELOCITY SHALL BE REPLACED WITH SPECIFIED SYSTEM WITH ALL REPLACEMENT COSTS PAID BY MANUFACTURER OF HOOD.  
 ANY CHANGES IN THE SPECIFIED SIZING OF POWER OR GAS LINES DUE TO THE USE OF ANY SYSTEM OTHER THAN THAT WHICH IS SPECIFIED IS THE RESPONSIBILITY OF THE MANUFACTURER AND MUST BE COORDINATED BY THE MANUFACTURER AND CONTRACTORS INVOLVED.

**CEILING HEIGHT NOTE**  
 IF HALTON COMPANY IS TO PROVIDE CEILING CLOSURE SYSTEMS, EXHAUST HOODS MUST BE PROVIDED FROM TO CEILING HEIGHT. CEILING HEIGHT MUST BE PROVIDED FROM TO CEILING FINISHED CEILING HEIGHT A.F.F.

**ELECTRICAL EQUIPMENT REQUIREMENTS**  
 FLUORESCENT LIGHT FIXTURE 40 WATT MAX BULB= 67 AMP EA.  
 RECESSED INCANDESCENT LIGHT FIXTURE 150 WATT MAX BULB= 1.25 AMP EA.  
 COBE INCANDESCENT LIGHT FIXTURE 100 WATT MAX BULB= .50 AMP EA.  
 LED LIGHT FIXTURES= .30 AMP EA.  
 CAPTURE JET FAN= .72 AMP EA.  
 \*\*ALL HOOD CIRCUITS ARE NOT TO EXCEED 15 AMP\*\*  
 \*\*NOTE: LIGHT BULBS/LAMPS, IF REQUIRED, ARE NOT PROVIDED BY HALTON\*\*

**INSTALLATION REQUIREMENTS**  
 KITCHEN EQUIPMENT CONTRACTOR'S REQUIREMENTS  
 1- PROVIDE DRAWINGS TO APPROPRIATE TRADES REFERENCING CONTRACTOR'S REQUIREMENTS FOR ELECTRICAL, MECHANICAL, PLUMBING, AND FINISH WORK.  
 2- DELIVER, ASSEMBLE AND INSTALL HALTON SYSTEM PER DRAWING.  
 3- FINISH WIRING AND PLUMBING DIAGRAMS TO END USER.  
 4- THE K.E.C. MUST NOTIFY HALTON OF ANY CHANGES IN EQUIPMENT OR BUILDING STRUCTURE. FIELD ADJUSTMENTS ARE THE RESPONSIBILITY OF THE K.E.C.  
 5- IF HALTON MANUAL EXHAUST VOLUME DAMPERS ARE PROVIDED, THE K.E.C. IS RESPONSIBLE FOR THEIR INSTALLATION OR TO MAKE ARRANGEMENTS WITH OTHER TRADES FOR THEIR INSTALLATION.  
 ELECTRICAL CONTRACTOR'S REQUIREMENTS  
 1- PROVIDE AND CONNECT ALL REQUIRED VOLTAGES, CONNECTORS, WIRING, CONDUIT, ETC., PER NEC AND ALL APPLICABLE LOCAL CODES.

**GENERAL SPECIFICATIONS**  
 1- HOOD CONSTRUCTION AND DESIGN MEETS NFPA 96 AND UL 710 STANDARD.  
 2- HOOD IS NSF AND ETI LISTED UNDER THE FOLLOWING FILE NUMBER: ETI #3085193ALE-002  
 3- ALL INSTALLATION WORK IS TO BE PERFORMED BY QUALIFIED PERSONS AND IN ACCORDANCE WITH STATE AND LOCAL BUILDING CODE REQUIREMENTS.  
 4- THE INSTALLATION SHALL BE IN ACCORDANCE WITH NFPA 96, REMOVAL OF SMOKE AND GREASE COOKING EQUIPMENT.  
 5- ALL EXHAUST DUCTWORK AND TRANSITIONS ARE TO BE PROVIDED BY THE HVAC CONTRACTOR.  
 6- CLEARANCE FROM HOOD AND DUCTS TO APPLICABLE BUILDING CODES.  
 7- FOR PROPER OPERATION OF THE HOOD SYSTEM, CONTRACTOR TO HAVE THE HOOD BALANCED AND TESTED TO ENSURE THAT THE EXHAUST REQUIREMENTS OF THE HOOD ARE MET.

**EXHAUST VOLUME DAMPER**  
 MODEL: MBD (Manual Balancing Damper)  
 TABLE:  

TAG	UNIT	QTY	INERT	QTY
1-1	12"	1	300 S.S.	300 S.S.
2	10"	2	300 S.S.	300 S.S.

 GENERAL NOTES:  
 - FIELD NOTES  
 - FLANGED FIELD CONNECTIONS REQUIRED  
 - BOLT TO BE PROVIDED BY OTHERS  
 - MANUFACTURER'S DRAWING FOR REFERENCED PARTS TO BE USED  
 - FACTORY NOTES SHOULD BE FOLLOWED  
 - THE INFORMATION CONTAINED HEREIN IS THE PROPERTY OF HALTON COMPANY AND IS NOT TO BE REPRODUCED OR TRANSMITTED IN ANY FORM OR BY ANY MEANS, ELECTRONIC OR MECHANICAL, INCLUDING PHOTOCOPYING, RECORDING, OR BY ANY INFORMATION STORAGE AND RETRIEVAL SYSTEM.

**EXHAUST VOLUME DAMPER**  
 MODEL: MBD (Manual Balancing Damper)  
 TABLE:  

TAG	UNIT	QTY	INERT	QTY
1-1	12"	1	300 S.S.	300 S.S.
2	10"	2	300 S.S.	300 S.S.

 GENERAL NOTES:  
 - FIELD NOTES  
 - FLANGED FIELD CONNECTIONS REQUIRED  
 - BOLT TO BE PROVIDED BY OTHERS  
 - MANUFACTURER'S DRAWING FOR REFERENCED PARTS TO BE USED  
 - FACTORY NOTES SHOULD BE FOLLOWED  
 - THE INFORMATION CONTAINED HEREIN IS THE PROPERTY OF HALTON COMPANY AND IS NOT TO BE REPRODUCED OR TRANSMITTED IN ANY FORM OR BY ANY MEANS, ELECTRONIC OR MECHANICAL, INCLUDING PHOTOCOPYING, RECORDING, OR BY ANY INFORMATION STORAGE AND RETRIEVAL SYSTEM.

**EXHAUST VOLUME DAMPER**  
 MODEL: MBD (Manual Balancing Damper)  
 TABLE:  

TAG	UNIT	QTY	INERT	QTY
1-1	12"	1	300 S.S.	300 S.S.
2	10"	2	300 S.S.	300 S.S.

 GENERAL NOTES:  
 - FIELD NOTES  
 - FLANGED FIELD CONNECTIONS REQUIRED  
 - BOLT TO BE PROVIDED BY OTHERS  
 - MANUFACTURER'S DRAWING FOR REFERENCED PARTS TO BE USED  
 - FACTORY NOTES SHOULD BE FOLLOWED  
 - THE INFORMATION CONTAINED HEREIN IS THE PROPERTY OF HALTON COMPANY AND IS NOT TO BE REPRODUCED OR TRANSMITTED IN ANY FORM OR BY ANY MEANS, ELECTRONIC OR MECHANICAL, INCLUDING PHOTOCOPYING, RECORDING, OR BY ANY INFORMATION STORAGE AND RETRIEVAL SYSTEM.

**INSTALLATION REQUIREMENTS**  
 KITCHEN EQUIPMENT CONTRACTOR'S REQUIREMENTS  
 1- PROVIDE DRAWINGS TO APPROPRIATE TRADES REFERENCING CONTRACTOR'S REQUIREMENTS FOR ELECTRICAL, MECHANICAL, PLUMBING, AND FINISH WORK.  
 2- DELIVER, ASSEMBLE AND INSTALL HALTON SYSTEM PER DRAWING.  
 3- FINISH WIRING AND PLUMBING DIAGRAMS TO END USER.  
 4- THE K.E.C. MUST NOTIFY HALTON OF ANY CHANGES IN EQUIPMENT OR BUILDING STRUCTURE. FIELD ADJUSTMENTS ARE THE RESPONSIBILITY OF THE K.E.C.  
 5- IF HALTON MANUAL EXHAUST VOLUME DAMPERS ARE PROVIDED, THE K.E.C. IS RESPONSIBLE FOR THEIR INSTALLATION OR TO MAKE ARRANGEMENTS WITH OTHER TRADES FOR THEIR INSTALLATION.  
 ELECTRICAL CONTRACTOR'S REQUIREMENTS  
 1- PROVIDE AND CONNECT ALL REQUIRED VOLTAGES, CONNECTORS, WIRING, CONDUIT, ETC., PER NEC AND ALL APPLICABLE LOCAL CODES.

**GENERAL SPECIFICATIONS**  
 1- HOOD CONSTRUCTION AND DESIGN MEETS NFPA 96 AND UL 710 STANDARD.  
 2- HOOD IS NSF AND ETI LISTED UNDER THE FOLLOWING FILE NUMBER: ETI #3085193ALE-002  
 3- ALL INSTALLATION WORK IS TO BE PERFORMED BY QUALIFIED PERSONS AND IN ACCORDANCE WITH STATE AND LOCAL BUILDING CODE REQUIREMENTS.  
 4- THE INSTALLATION SHALL BE IN ACCORDANCE WITH NFPA 96, REMOVAL OF SMOKE AND GREASE COOKING EQUIPMENT.  
 5- ALL EXHAUST DUCTWORK AND TRANSITIONS ARE TO BE PROVIDED BY THE HVAC CONTRACTOR.  
 6- CLEARANCE FROM HOOD AND DUCTS TO APPLICABLE BUILDING CODES.  
 7- FOR PROPER OPERATION OF THE HOOD SYSTEM, CONTRACTOR TO HAVE THE HOOD BALANCED AND TESTED TO ENSURE THAT THE EXHAUST REQUIREMENTS OF THE HOOD ARE MET.

**INSTALLATION REQUIREMENTS**  
 KITCHEN EQUIPMENT CONTRACTOR'S REQUIREMENTS  
 1- PROVIDE DRAWINGS TO APPROPRIATE TRADES REFERENCING CONTRACTOR'S REQUIREMENTS FOR ELECTRICAL, MECHANICAL, PLUMBING, AND FINISH WORK.  
 2- DELIVER, ASSEMBLE AND INSTALL HALTON SYSTEM PER DRAWING.  
 3- FINISH WIRING AND PLUMBING DIAGRAMS TO END USER.  
 4- THE K.E.C. MUST NOTIFY HALTON OF ANY CHANGES IN EQUIPMENT OR BUILDING STRUCTURE. FIELD ADJUSTMENTS ARE THE RESPONSIBILITY OF THE K.E.C.  
 5- IF HALTON MANUAL EXHAUST VOLUME DAMPERS ARE PROVIDED, THE K.E.C. IS RESPONSIBLE FOR THEIR INSTALLATION OR TO MAKE ARRANGEMENTS WITH OTHER TRADES FOR THEIR INSTALLATION.  
 ELECTRICAL CONTRACTOR'S REQUIREMENTS  
 1- PROVIDE AND CONNECT ALL REQUIRED VOLTAGES, CONNECTORS, WIRING, CONDUIT, ETC., PER NEC AND ALL APPLICABLE LOCAL CODES.

**GENERAL SPECIFICATIONS**  
 1- HOOD CONSTRUCTION AND DESIGN MEETS NFPA 96 AND UL 710 STANDARD.  
 2- HOOD IS NSF AND ETI LISTED UNDER THE FOLLOWING FILE NUMBER: ETI #3085193ALE-002  
 3- ALL INSTALLATION WORK IS TO BE PERFORMED BY QUALIFIED PERSONS AND IN ACCORDANCE WITH STATE AND LOCAL BUILDING CODE REQUIREMENTS.  
 4- THE INSTALLATION SHALL BE IN ACCORDANCE WITH NFPA 96, REMOVAL OF SMOKE AND GREASE COOKING EQUIPMENT.  
 5- ALL EXHAUST DUCTWORK AND TRANSITIONS ARE TO BE PROVIDED BY THE HVAC CONTRACTOR.  
 6- CLEARANCE FROM HOOD AND DUCTS TO APPLICABLE BUILDING CODES.  
 7- FOR PROPER OPERATION OF THE HOOD SYSTEM, CONTRACTOR TO HAVE THE HOOD BALANCED AND TESTED TO ENSURE THAT THE EXHAUST REQUIREMENTS OF THE HOOD ARE MET.

**PROJECT:**  
 BOWDEN  
 LOCATION: ONTARIO  
 DRAWN BY: GD DATE: 5/21/13  
 SCALE: NOT TO SCALE  
 CONSULTANT:

**MAIL APPROVED DRAWINGS TO APPROPRIATE FACTORY BELOW:**  
 HALTON CO. (CANADA)  
 1021 BREVIN PLACE  
 MISSISSAUGA, ON L4W 3R7  
 1-905-624-0301

**WEBSITE: WWW.HALTONCOMPANY.COM**  
 HALTON CO. (USA)  
 101 INDUSTRIAL DRIVE  
 SCOTTSVILLE, KY 42164  
 1-270-237-5600

**REVISION DESCRIPTION**

REV.	DESCRIPTION	BY	DATE
1			
2			
3			
4			
5			
6			
7			

**REVISION DESCRIPTION**

REV.	DESCRIPTION	BY	DATE
1			
2			
3			
4			
5			
6			
7			

**REVISION DESCRIPTION**

REV.	DESCRIPTION	BY	DATE
1			
2			
3			
4			
5			
6			
7			

**REVISION DESCRIPTION**

REV.	DESCRIPTION	BY	DATE
1			
2			
3			
4			
5			
6			
7			

**REVISION DESCRIPTION**

REV.	DESCRIPTION	BY	DATE
1			
2			
3			
4			
5			
6			
7			

**REVISION DESCRIPTION**

REV.	DESCRIPTION	BY	DATE
1			
2			
3			
4			
5			
6			
7			

**REVISION DESCRIPTION**

REV.	DESCRIPTION	BY	DATE
1			
2			
3			
4			
5			
6			
7			

**REVISION DESCRIPTION**

REV.	DESCRIPTION	BY	DATE
1			
2			
3			
4			
5			
6			
7			

**REVISION DESCRIPTION**

REV.	DESCRIPTION	BY	DATE
1			
2			
3			
4			
5			
6			
7			

**REVISION DESCRIPTION**

REV.	DESCRIPTION	BY	DATE
1			
2			
3			
4			
5			
6			
7			

**REVISION DESCRIPTION**

REV.	DESCRIPTION	BY	DATE
1			
2			
3			
4			
5			
6			
7			

**REVISION DESCRIPTION**

REV.	DESCRIPTION	BY	DATE
1			
2			
3			
4			
5			
6			
7			

**REVISION DESCRIPTION**

REV.	DESCRIPTION	BY	DATE
1			
2			
3			
4			
5			
6			
7			

**REVISION DESCRIPTION**

REV.	DESCRIPTION	BY	DATE
1			
2			
3			
4			
5			
6			
7			

**REVISION DESCRIPTION**

REV.	DESCRIPTION	BY	DATE
1			
2			
3			
4			
5			
6			
7			

**REVISION DESCRIPTION**

REV.	DESCRIPTION	BY	DATE
1			
2			
3			
4			
5			
6			
7			

**REVISION DESCRIPTION**

REV.	DESCRIPTION	BY	DATE
1			
2			
3			
4			
5			
6			
7			

**REVISION DESCRIPTION**

REV.	DESCRIPTION	BY	DATE
1			
2			
3			
4			
5			
6			
7			

**REVISION DESCRIPTION**

REV.	DESCRIPTION	BY	DATE
1			
2			
3			
4			
5			
6			
7			

**REVISION DESCRIPTION**

REV.	DESCRIPTION	BY	DATE
1			
2			
3			
4			
5			
6			
7			

**REVISION DESCRIPTION**

REV.	DESCRIPTION	BY	DATE
1			
2			
3			
4			
5			
6			
7			

**REVISION DESCRIPTION**

REV.	DESCRIPTION	BY	DATE
1			
2			
3			
4			
5			
6			
7			

**REVISION DESCRIPTION**

REV.	DESCRIPTION	BY	DATE
1			
2			
3			
4			
5			
6			
7			

**REVISION DESCRIPTION**

REV.	DESCRIPTION	BY	DATE
1			
2			
3			
4			
5			
6			
7			

**REVISION DESCRIPTION**

REV.	DESCRIPTION	BY	DATE
1			
2			
3			
4			
5			
6			
7			

DIM. UNITS NUMBER	HOOD MODEL	EXHAUST AIR FLOW REQUIREMENTS				GREASE EXTRACTOR				HOOD CONSTRUCTION	HOOD WEIGHT
		T.A.B. PORT STATIC PRESSURE	TOTAL HOOD STATIC PRESSURE	EXHAUST COLLAR QTY	EXHAUST COLLAR LENGTH	SIZE L	SIZE H	TYPE			
M/PERAL UNITS	KVE	.11 "WG	.224 "WG	1	12"	5	20" 13"	KSA	ALL 18GA. 304 S.S.	835lb	
METRIC UNITS	KVE	.027 kPa	.056 kPa	1	305 mm	229 mm	508 330	KSA	ALL 18GA. 304 S.S.	380 kg	

HOOD INFORMATION TABLE

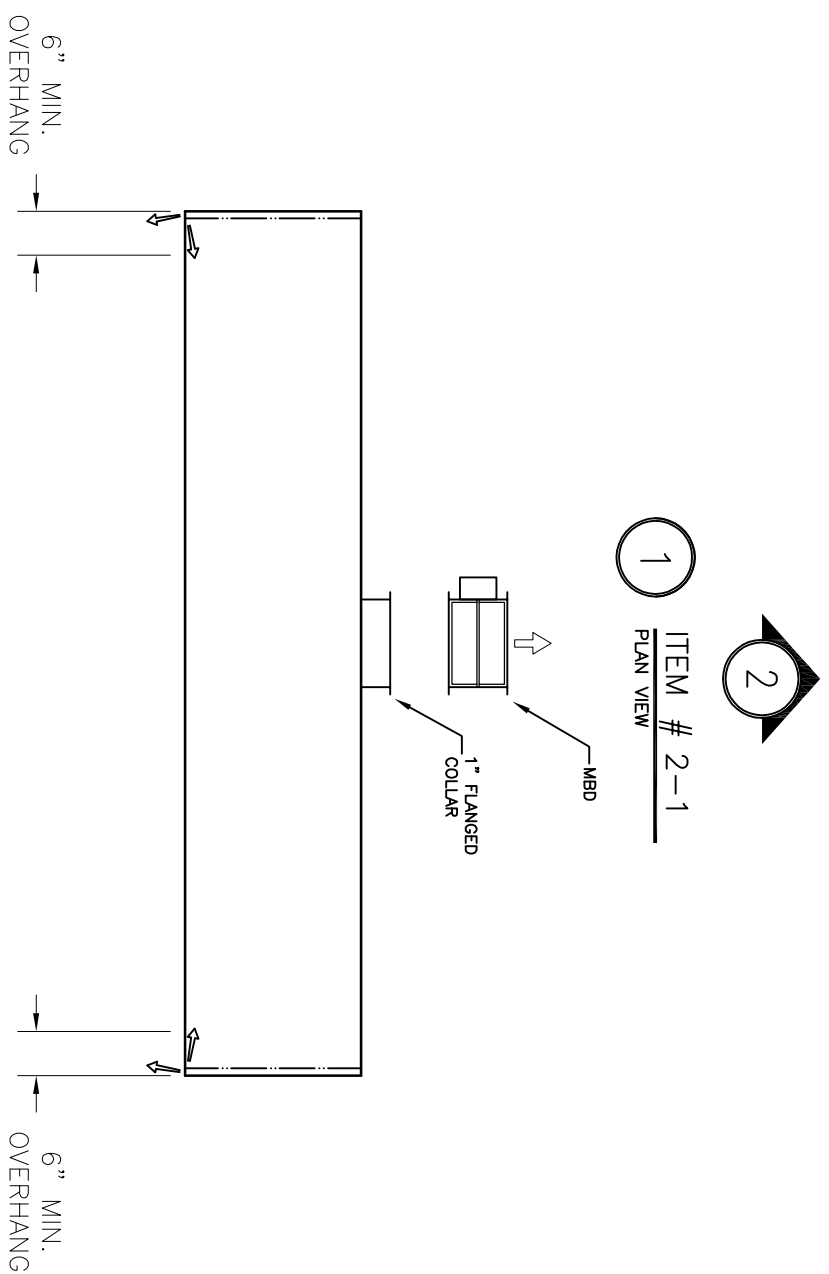
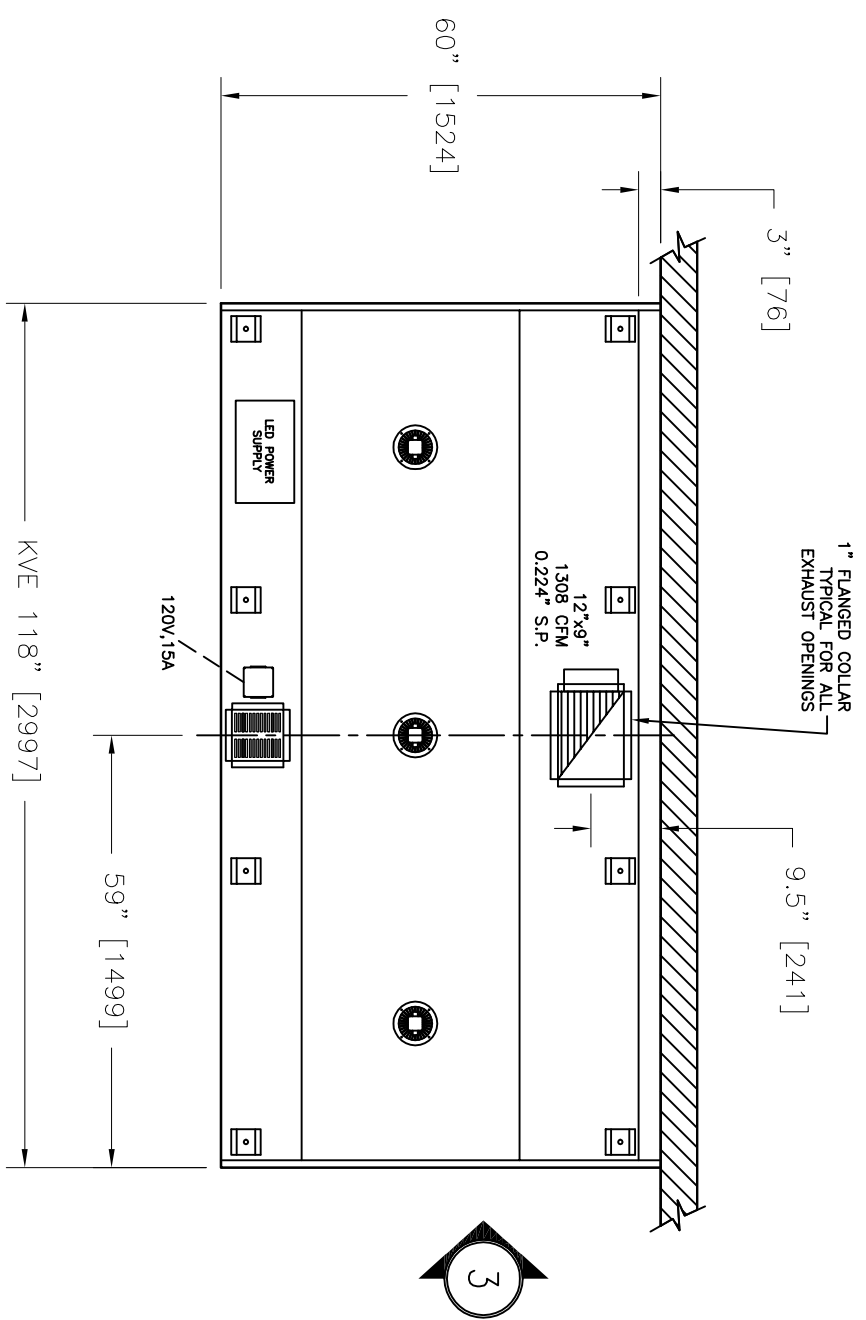

ITEM # 2-1  
ELEVATION VIEW

ITEM # 2-1  
SECTION VIEW

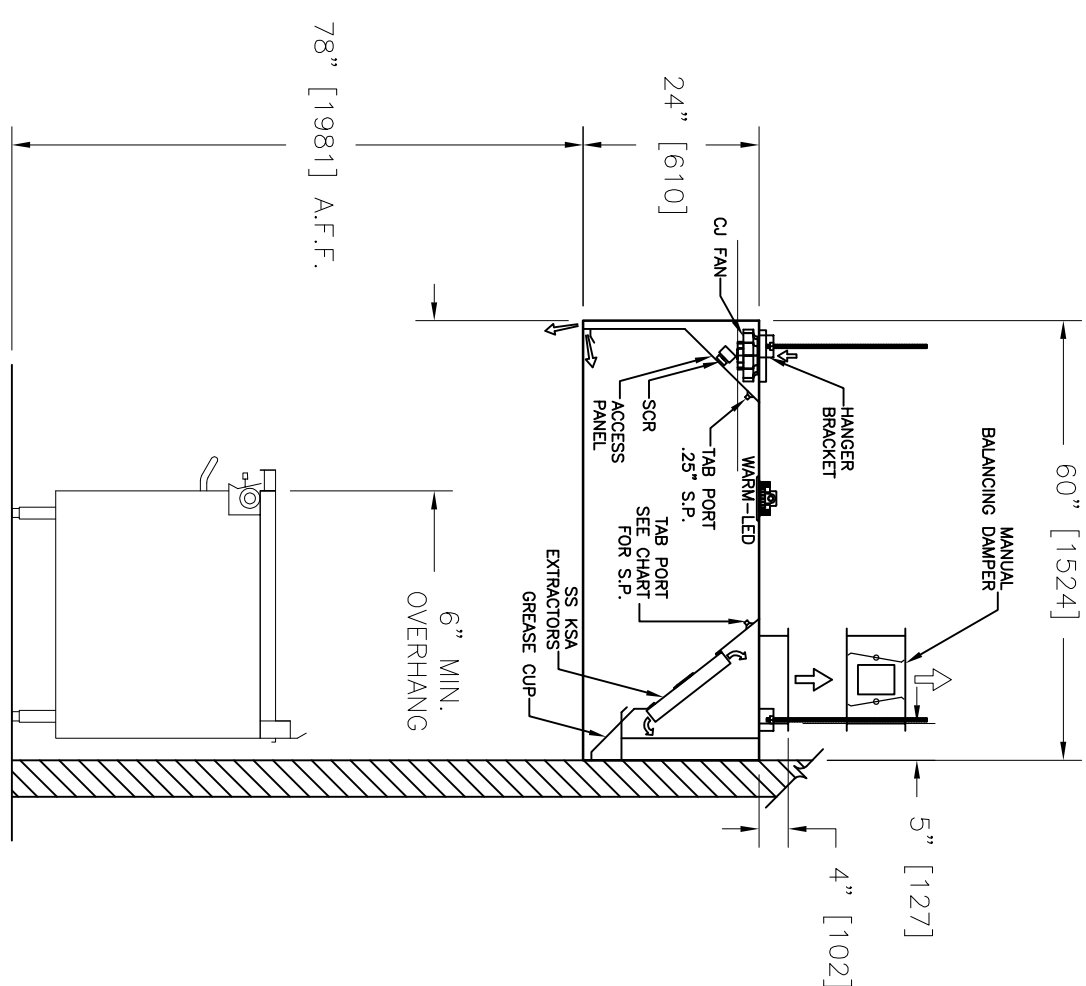

M/D SHIPPED LOOSE

EXHAUST VOLUME DAMPER  
MODEL: MBD (Manual Balancing Damper)

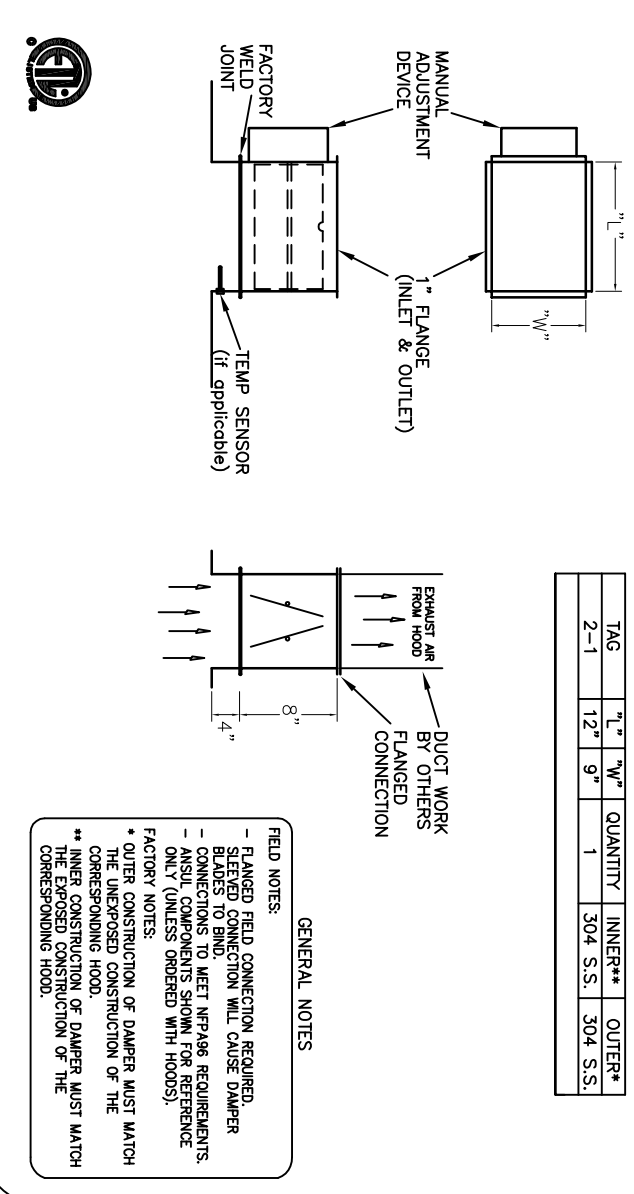

GENERAL NOTES:  
 - FLANGED COLLAR CONNECTION NUMBERS  
 - REFER TO THE DRAWING FOR THE COLLAR CONNECTION NUMBERS  
 - ALL DIMENSIONS ARE IN INCHES UNLESS OTHERWISE NOTED  
 - FACTORY WELDED JOINTS SHALL BE PERFORMED BY QUALIFIED PERSONNEL  
 - THE MANUFACTURER SHALL BE RESPONSIBLE FOR THE PROPER INSTALLATION OF THE DAMPER  
 - THE DAMPER SHALL BE INSTALLED IN ACCORDANCE WITH THE MANUFACTURER'S INSTALLATION INSTRUCTIONS

GENERAL SPECIFICATIONS

- HOOD CONSTRUCTION AND DESIGN MEETS NFPA 96 AND UL 710 STANDARD.
- HOOD IS NSF AND ETL LISTED UNDER THE FOLLOWING FILE NUMBER: ETL #30851932E-002
- ALL INSTALLATION WORK IS TO BE PERFORMED BY QUALIFIED PERSONS AND IN ACCORDANCE WITH STATE AND LOCAL BUILDING CODE REQUIREMENTS.
- THE INSTALLATION SHALL BE IN ACCORDANCE WITH NFPA 96, REMOVAL OF SMOKE AND GREASE LOUVER VAPORS FROM COMMERCIAL COOKING EQUIPMENT.
- ALL EXHAUST DUCTWORK AND TRANSITIONS ARE TO BE PROVIDED BY THE HVAC CONTRACTOR.
- SEPARATE FROM HOOD AND QUITS TO APPLICABLE BUILDING CODES.
- FOR PROPER OPERATION OF THE HOOD SYSTEM, CONTRACTOR TO HAVE THE HOOD BALANCED AND TESTED TO ENSURE THAT THE EXHAUST ARE MET.

INSTALLATION REQUIREMENTS

- KITCHEN EQUIPMENT CONTRACTOR'S REQUIREMENTS
- PROVIDE DRAWINGS TO APPROPRIATE TRADES REPRESENTING PLUMBING SERVICE AND COORDINATE FINAL CONNECTIONS.
  - DELIVER, ASSEMBLE AND INSTALL HALTON SYSTEM PER DRAWING.
  - FINISH WIRING AND PLUMBING DRAWINGS TO END USER.
  - THE K.E.C. MUST NOTIFY HALTON OF ANY CHANGES IN EQUIPMENT OR BUILDING STRUCTURE. FIELD MODIFICATIONS ARE THE RESPONSIBILITY OF THE K.E.C.
  - IF HALTON MANUAL EXHAUST VOLUME DAMPERS ARE PROVIDED, THE K.E.C. IS RESPONSIBLE FOR THEIR INSTALLATION OR TO MAKE ARRANGEMENTS WITH OTHER TRADES FOR THEIR INSTALLATION.
- ELECTRICAL CONTRACTOR'S REQUIREMENTS
- PROVIDE AND CONNECT ALL REQUIRED VOLTAGES, CONNECTORS, WIRING, CONDUIT, ETC., PER NEC AND ALL APPLICABLE LOCAL CODES.

ELECTRICAL EQUIPMENT REQUIREMENTS

- FLUORESCENT LIGHT FIXTURE 40 WATT MAX BULB= 67 AMP EA.
  - RECESSED INCANDESCENT LIGHT FIXTURE 150 WATT MAX BULB= 1.25 AMP EA.
  - COOKING APPLIANCE LIGHT FIXTURE 100 WATT MAX BULB= .83 AMP EA.
  - LED LIGHT FIXTURES= .30 AMP EA.
  - CAPTURE LET FAN= .72 AMP EA.
- \*\*ALL HOOD CIRCUITS ARE NOT TO EXCEED 15 AMP\*\*  
 \*\*NOTE: LIGHT BULBS/LAMPS, IF REQUIRED, ARE NOT PROVIDED BY HALTON\*\*

CEILING HEIGHT NOTE

IF HALTON COMPANY IS TO PROVIDE CEILING CLOSURE PANELS, EACH CEILING JOINT MUST BE FINISHED TO RELEASE CEILING HEIGHT MUST BE PROVIDED FROM TO RELEASE FINISHED CEILING HEIGHT A.F.F.:

HANGER BRACKET LAYOUT

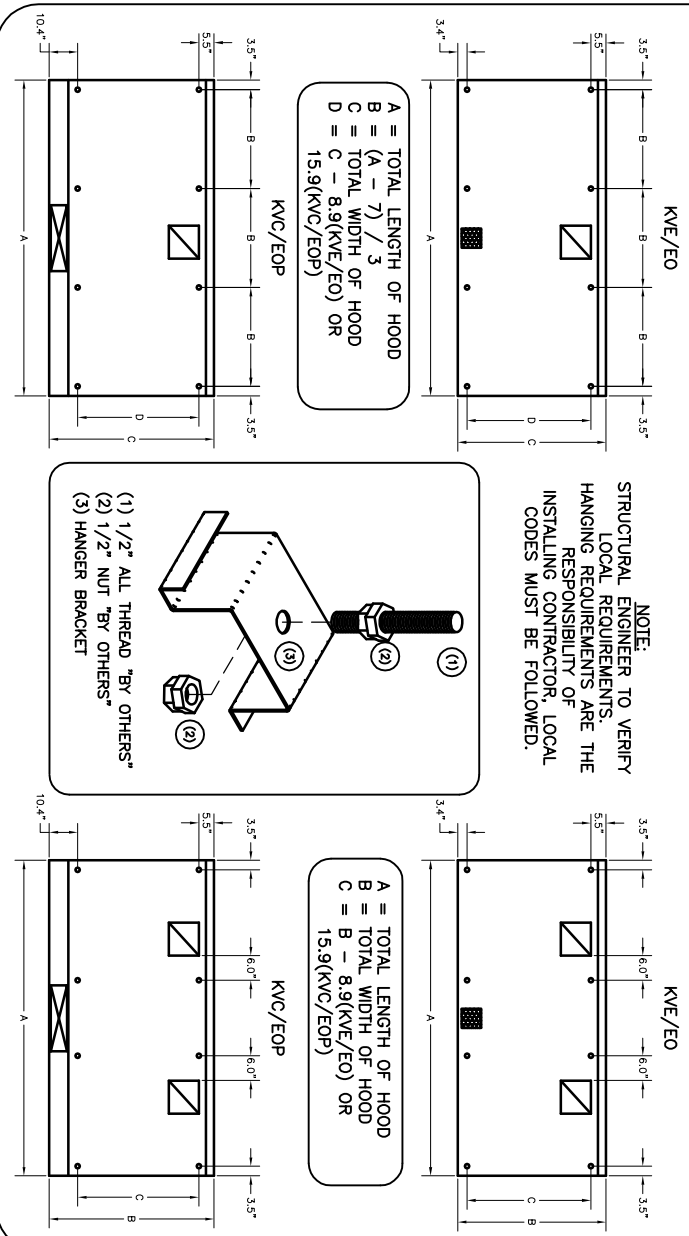

Typical wiring of Capture-Jet fan REMOTE SWITCH PANEL BY OTHERS

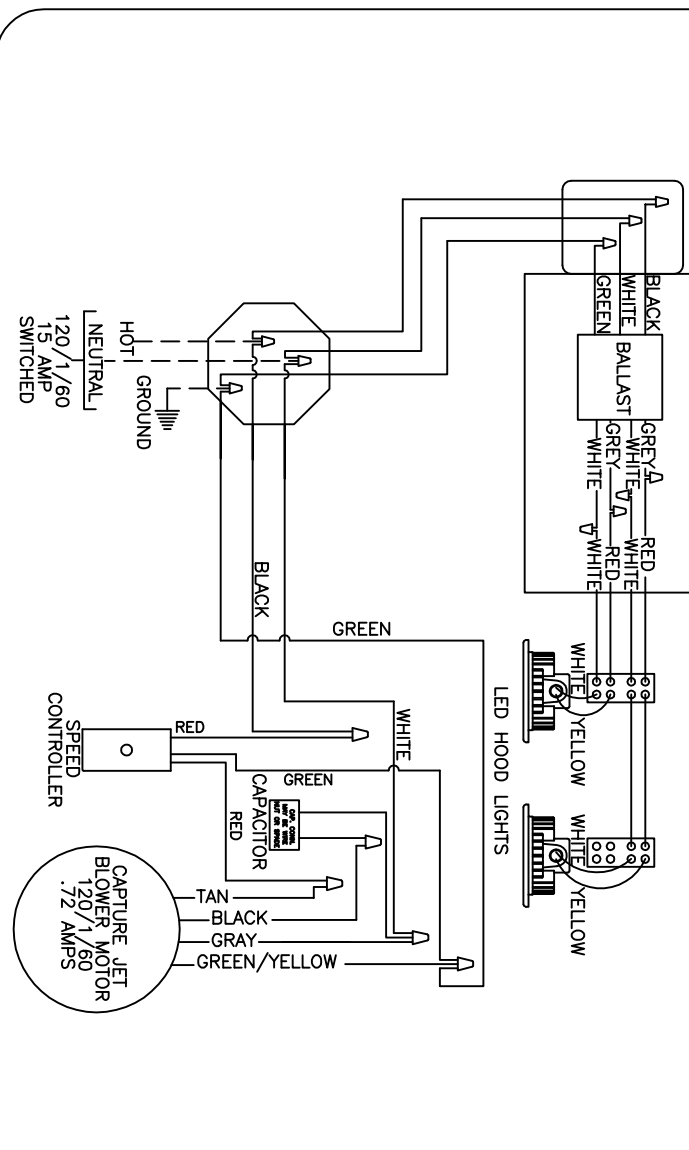

LED POWER SUPPLY UNIT

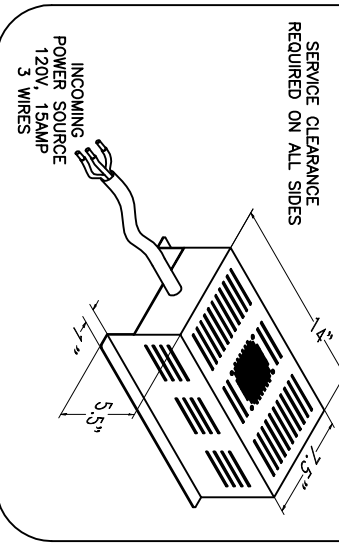

PERFORMANCE CRITERIA

OTHER MANUFACTURERS WISHING TO OBTAIN AN ALTERNATE TO THE SPECIFIED MANUFACTURER MUST SUBMIT A WRITTEN GUARANTEE TO THE OFFICE OF THE SHOPPING CONSULTANT. APPLICATION MUST BE RECEIVED BY THE SHOPPING CONSULTANT ON OR BEFORE THE DATE OF THE BID DATE. ANY ALTERNATE SYSTEM MUST MEET THE SAME PERFORMANCE AND CONTAMINANT EXHAUST AIR FLOW CAPACITY AS SPECIFIED IN THE SPECIFICATION. REQUESTS FOR APPROVAL MUST INCLUDE GREASE EXTRACTION PERFORMANCE DATA (VUCON SIZE VS. EXTRACTION EFFICIENCY) AND MANUFACTURER'S OWN CALCULATED HEAT LOAD OF COOKING EQUIPMENT BENEATH THE HOOD.

ANY CHANGES IN THE SPECIFIED SIZING OF POWER SUPPLY, WIRING, OR LIGHTING SHALL BE THE RESPONSIBILITY OF THE MANUFACTURER AND MUST BE COMMANDED BY THE HOOD MANUFACTURER AND CONTRACTORS INVOLVED.

KSA GREASE EXTRACTOR

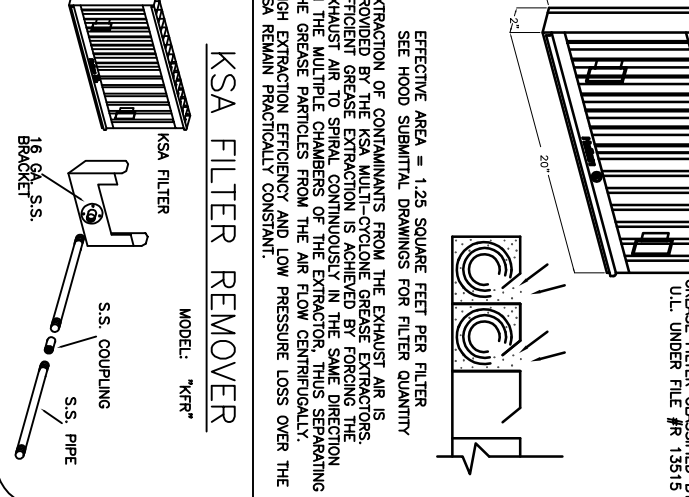

KSA FILTER REMOVER

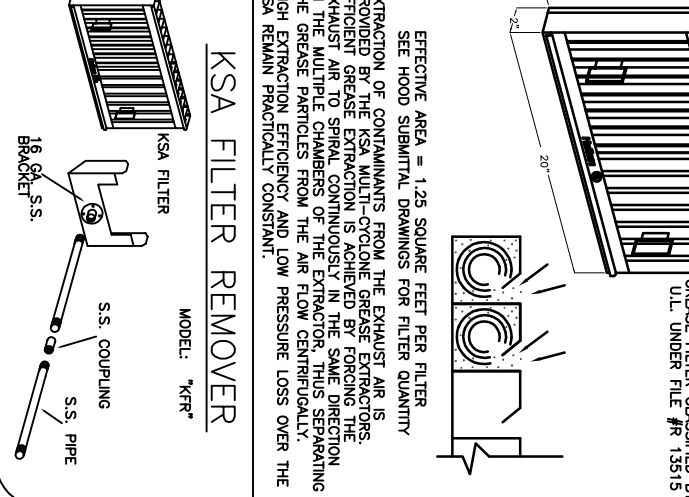

Typical wiring of Capture-Jet fan REMOTE SWITCH PANEL BY OTHERS

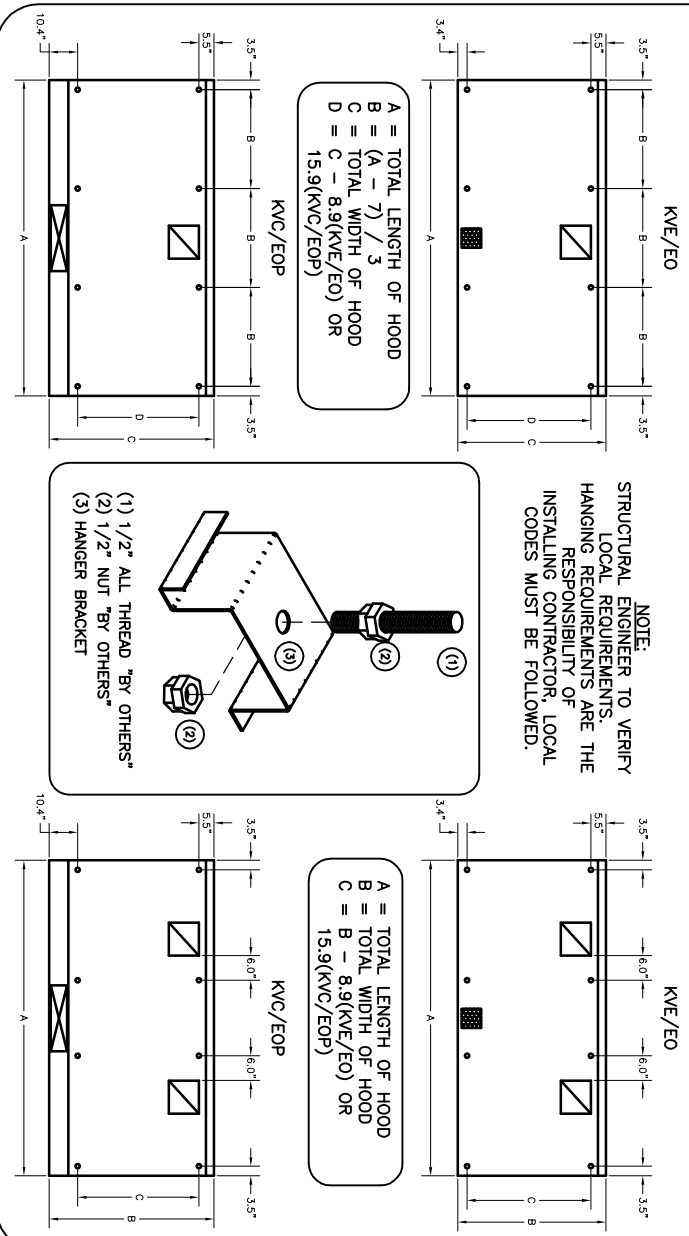

LED POWER SUPPLY UNIT

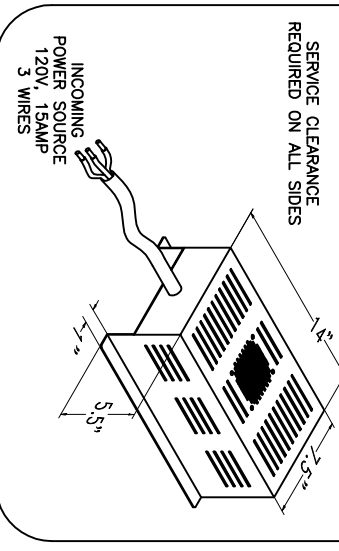

THIS DRAWING MUST BE CHECKED, SIGNED AND RETURNED TO THE APPROPRIATE FACTORY. PLEASE VERIFY THE FOLLOWING:

- ALL DIMENSIONAL INFORMATION, MOUNTING POSITIONS AND CLEARANCES.
- THE LOCATION AND TYPE OF COOKING EQUIPMENT.

NOTE TO ARCHITECT  
 ANY CHANGES IN COOKING EQUIPMENT SUCH AS INCREASED ENERGY INPUTS OR EQUIPMENT POSITION MAY AFFECT EXHAUST AIRFLOW. HALTON MUST BE NOTIFIED IF ANY OF THESE CHANGES OCCUR. A RECALCULATION EXHAUST AIRFLOW MAY BE REQUIRED.

APPROVED FOR FABRICATION  
 WITH NO CHANGES  WITH CHANGES AS NOTED

APPROVED BY: \_\_\_\_\_ DATE: \_\_\_\_\_



MAIL APPROVED DRAWINGS TO APPROPRIATE FACTORY BELOW: WEBSITE: WWW.HALTONCOMPANY.COM

HALTON CO. (CANADA)  
 1021 BREVILLE PLACE  
 MISSISSAUGA, ON L4W 3R7  
 1-905-624-0301

HALTON CO. (USA)  
 101 INDUSTRIAL DRIVE  
 SCOTTSVILLE, KY 42164  
 1-270-237-5600

REV.	REVISION DESCRIPTION	BY	DATE
1			
2			
3			
4			
5			
6			
7			

PROJECT: BOWDEN

LOCATION: ONTARIO

DRAWN BY: GD DATE: 5/21/13

SCALE: NOT TO SCALE

CONSULTANT:



DRAWING No.: C13-239

REV. NO.: 0 SHEET 2 of 4



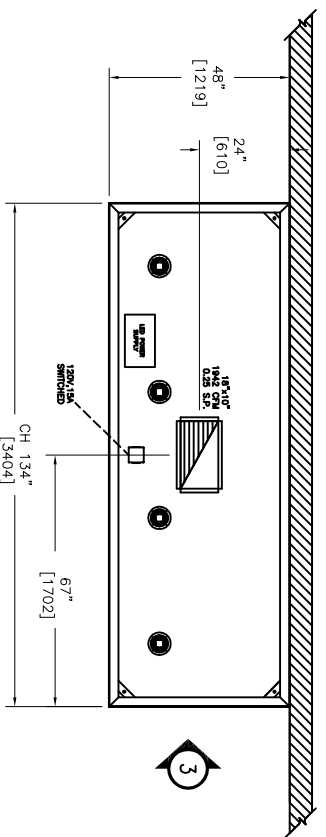

1 ITEM # 4-1  
FRONT VIEW

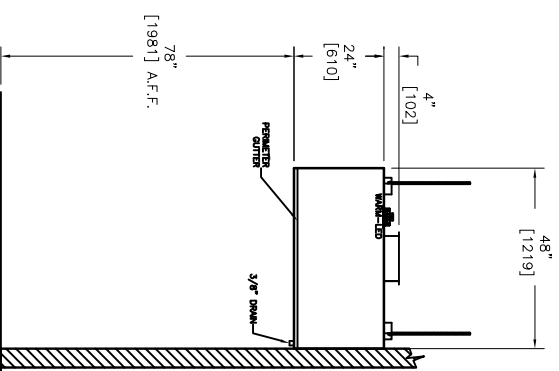
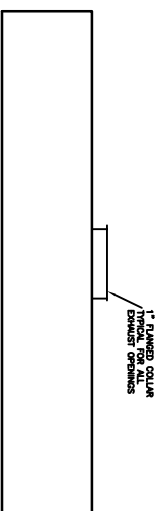

3 ITEM # 4-1  
SECTION VIEW

HOOD INFORMATION TABLE

EXHAUST AIR FLOW REQUIREMENTS				GRABSE EXTRACTOR				HOOD	
QUL UNITS	HOOD MODEL	EXHAUST AIR FLOW REQUIREMENT	EXHAUST COLLAR	QTY	L	H	TYPE	CONSTRUCTION	HOOD WEIGHT
4-1	CH	1942 CH4	N/A	25	78"	15"	N/A	ALL 18GA. 304 S.S.	300LB
4-1	CH	917 I/S	N/A	1	18"	10"	N/A	ALL 18GA. 304 S.S.	229 kg

LED POWER SUPPLY UNIT

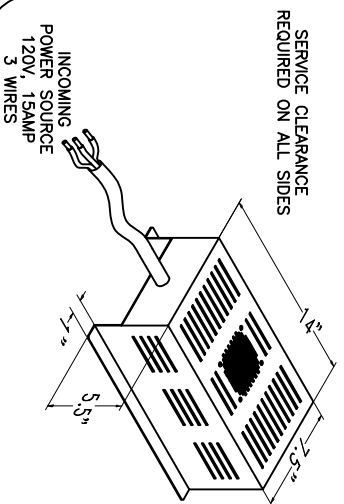

Typical wiring of REMOTE SWITCH PANEL BY OTHERS

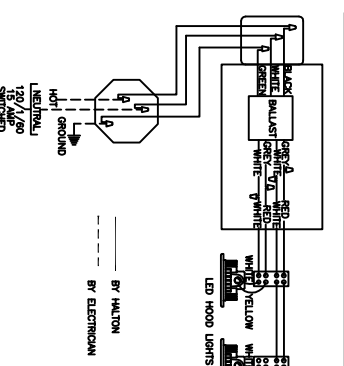

HANGER BRACKET LAYOUT

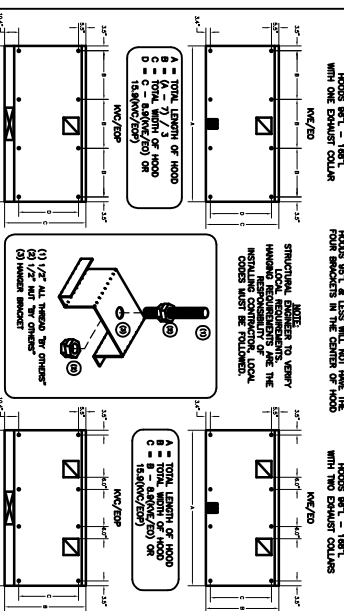

CEILING HEIGHT NOTE

F. HALTON COMPANY IS TO PROVIDE CEILING CLOSEURE PANELS. THE EXACT DIMENSION OF THE FINISHED CEILING HEIGHT MUST BE PROVIDED PRIOR TO RELEASE.

FINISHED CEILING HEIGHT A.F.F.: \_\_\_\_\_

ELECTRICAL EQUIPMENT REQUIREMENTS

- FLUORESCENT LIGHT FEATURE 40 WATT MAX BULBS- 67 AMP EA.
- RECESSED INCANDESCENT LIGHT FEATURE 150 WATT MAX BULBS- 1.25 AMP EA.
- GLOBE INCANDESCENT LIGHT FEATURE 100 WATT MAX BULBS- .25 AMP EA.
- LED LIGHT FEATURES- 30 AMP EA.

\*\*ALL HOOD CIRCUITS ARE NOT TO EXCEED 15 AMP\*\*  
\*\*NOTE: LIGHT BULBS/AMPS, IF REQUIRED, ARE NOT PROVIDED BY HALTON\*\*

INSTALLATION REQUIREMENTS

- KITCHEN EQUIPMENT CONTRACTOR'S REQUIREMENTS
- PROVIDE DRAWINGS TO APPROPRIATE TRADES REPRESENTING UTILITY SERVICE AND COORDINATE PAUL CONNECTION.
  - DRIVER ASSEMBLY AND INSTALL HALTON SYSTEM PER DRAWING.
  - FINISH WIRING AND PLUMBING DRAWINGS TO END USER.
  - THE K.E.C. MUST NOTIFY HALTON OF ANY CHANGES IN EQUIPMENT OR BUILDING STRUCTURE. FIELD MODIFICATIONS ARE THE RESPONSIBILITY OF THE K.E.C.
  - IF HALTON MANUAL EXHAUST VOLUME DAMPERS ARE PROVIDED, THE K.E.C. IS RESPONSIBLE FOR THEIR INSTALLATION OR TO MAKE ARRANGEMENTS WITH OTHER TRADES FOR THEIR INSTALLATION.
- ELECTRICAL CONTRACTOR'S REQUIREMENTS
- PROVIDE AND CONNECT ALL REQUIRED VOLTAGES, CONNECTIONS, WIRING, CONDUIT, ETC., PER NEC AND ALL APPLICABLE LOCAL CODES.

GENERAL SPECIFICATIONS

- HOOD MODEL CONSTRUCTION AND DESIGN MEETS NFPA 96 AND UL 710 STANDARD.
- HOOD IS NSF AND ETL LISTED UNDER THE FOLLOWING FILE NUMBER: ETL #518978787-001
- ALL INSTALLATION WORK IS TO BE PERFORMED BY QUALIFIED PERSONS AND IN ACCORDANCE WITH ALL APPLICABLE LOCAL BUILDING CODE REQUIREMENTS.
- THE INSTALLATION SHALL BE IN ACCORDANCE WITH NFPA 96, REMOVAL OF SMOKE AND GREASE COOKING EQUIPMENT - COMMERCIAL.
- ALL EXHAUST DUCTWORK AND TRANSMISSIONS CONTROLS PROVIDED BY THE HVAC CONTRACTOR.
- CLEARANCE FROM HOOD AND DUCTS TO COMBUSTIBLE MATERIAL SHALL BE PER APPLICABLE BUILDING CODES.
- FOR PROPER OPERATION OF THE HOOD SYSTEM, IT IS THE RESPONSIBILITY OF THE GENERAL CONTRACTOR TO HAVE THE HOOD BALANCED AND TESTED FOR PROPER EXHAUST AIRFLOW. PROPER POSITION MAY AFFECT EXHAUST AIRFLOW. NOTIFICATION OF THESE CHANGES OCCUR, A RECALCULATION EXHAUST AIRFLOW MAY BE REQUIRED.

THIS DRAWING MUST BE CHECKED, SIGNED AND RETURNED TO THE APPROPRIATE FACTORY. PLEASE VERIFY THE FOLLOWING:

- ALL DIMENSIONAL INFORMATION, MOUNTING POSITIONS AND CLEARANCES.
- THE LOCATION AND TYPE OF COOKING EQUIPMENT.

NOTE TO APPROVER

ANY CHANGES IN COOKING EQUIPMENT SUCH AS INCREASED ENERGY INPUTS OR EQUIPMENT POSITION MAY AFFECT EXHAUST AIRFLOW. NOTIFICATION OF THESE CHANGES OCCUR, A RECALCULATION EXHAUST AIRFLOW MAY BE REQUIRED.

- APPROVED FOR FABRICATION
- WITH NO CHANGES  WITH CHANGES AS NOTED

APPROVED BY \_\_\_\_\_

DATE \_\_\_\_\_

MAIL APPROVED DRAWINGS TO APPROPRIATE FACTORY BELOW: WEBSITE: WWW.HALTONCOMPANY.COM

HALTON CO. (CANADA) 1021 BREVIK PLACE MISSISSAUGA, ON L4W 3R7 1-905-624-0301

HALTON CO. (USA) 101 INDUSTRIAL DRIVE SCOTTSVILLE, KY 42164 1-270-237-5600

REV.	REVISION DESCRIPTION	BY	DATE
1			
2			
3			
4			
5			
6			
7			



PROJECT: BOWDEN  
LOCATION: ON  
DRAWN BY: GD  
SCALE:  
CONSULTANT:



DRAWING No.: C13-239  
REV. NO.: 0  
SHEET 4 of 4