

# Champion®

The Dishwashing Machine Specialists

Project \_\_\_\_\_  
Item No. \_\_\_\_\_  
Quantity \_\_\_\_\_

64 SERIES RACK CONVEYOR

## STANDARD FEATURES

- **ENERGY STAR® Qualified**
- Dual-pawl cradle drive system
- One-piece cast stainless steel upper & lower spray arm assemblies
- Internal removable scrap basket and two-piece scrap screen
- Standard vertical opening accommodates 18" x 26" sheet pans
- Wide 26" leakproof doors on wash/rinse
- Anti-jam conveyor drive system
- Energy Sentinel (Idle pump shut-off)
- Convenient top-mounted controls
- Automatic tank fill
- Door safety switch
- Door activated drain closure
- Enclosure panels (front and sides)
- Stainless steel heavy-gauge construction, including base and feet
- Electric tank heat
- Wash/rinse pump 2 Hp motors
- Stainless steel pump and impeller
- Two-point electrical connection
- Vent fan control switch
- Stainless steel rear manifolds

## PREWASH MODELS ONLY

- External prewash scrap basket
- Prewash pump 1 Hp motor
- Wide 15-1/2" leak proof door internally fitted (22" Prewash)
- Wide 26" leak proof door internally fitted (36" Prewash)

## 64 SERIES

64, 86 PW, 90 FFPW, 100 HDPW  
High-Temperature  
Rack Conveyor Dishwashing Machine



Model 64 Shown with  
Vent Cowl and Damper Option

## SPECIFIER STATEMENT

Specified unit will be Champion model 64 Series high temperature rack conveyor dishwashing machine. Features top mounted control cabinet; upper and lower one-piece stainless steel spray arm assemblies, removable internal scrap baskets with two-piece scrap screen. Large 26" front access doors with double-hook safety latch (Prewash unit has additional 15-1/2" or 26" wash door). Anti-jam conveyor drive system.

1 year parts and labor warranty.



Champion Industries, Inc.  
2674 N. Service Road,  
Jordan Station, Ontario, Canada L0R 1S0  
Tel: 905/562-4195 Fax: 905/562-4618

Champion Industries, Inc.  
3765 Champion Blvd., Winston-Salem, NC 27105  
Tel: 336/661-1556 Fax: 336/661-1979  
[www.championindustries.com](http://www.championindustries.com)



# Champion®

The Dishwashing Machine Specialists

## 64 SERIES

64, 86 PW, 90 FFPW, 100 HDPW  
High-Temperature  
Rack Conveyor Dishwashing Machine

### SPECIFICATIONS

#### Capacity

Racks per hr. (NSF rated)	277
Wash tank (US gal.)	21
Conveyor speed (ft./min.)	7.7

#### Motor Horsepower

Drive	1/6
Wash	2
Rinse	2

#### Water Consumption

US Gal. per hr. (max. use)	124
US Gal. per rack	.45

#### Heating

Tank Heat, electric (kW)	25
Tank heat, steam (lbs./hr. required at 15 PSI flow pressure)	125
Electric booster (built-in) (kW supplied for 40°F rise)	15
Electric booster (built-in) (kW supplied for 70°F rise)	24
Steam booster (lbs./hr. required for 40°F rise)	75
Steam booster (lbs./hr. required for 70°F rise)	120

*Booster heaters completely inter plumbed,  
Controls are interwired*

#### Venting

Load end (minimum CFM)	200
Unload end (minimum CFM)	400

#### Standard 20" x 20" rack complement

Peg	2
Flat	1



**NEW** Exclusive Digital Gauges



**NEW** Durable Stainless Steel Start/Stop Switches



One-Piece Cast Stainless Steel Spray Assembly



Stainless Steel Built-in Nested Booster



Two-Piece Scrap Screen



Built-in Scrap Basket for ease of cleaning



# 64 SERIES

**64, 86 PW, 90 FFPW, 100 HDPW**  
High-Temperature  
Rack Conveyor Dishwashing Machine

# Champion®

The Dishwashing Machine Specialists

**MODEL 64** Shipping weight crated: **1200 lbs.**

Dimensions shown in inches [mm]

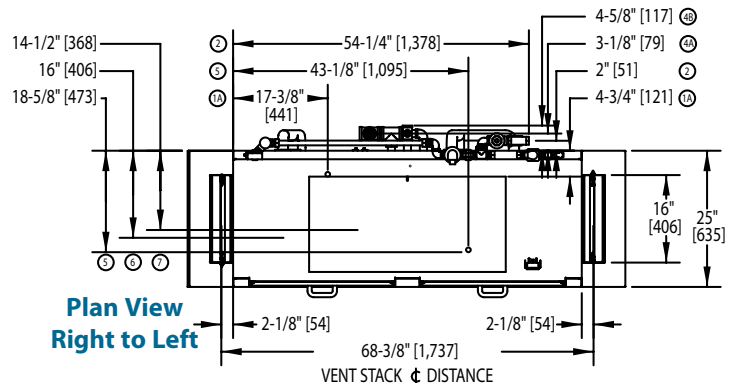
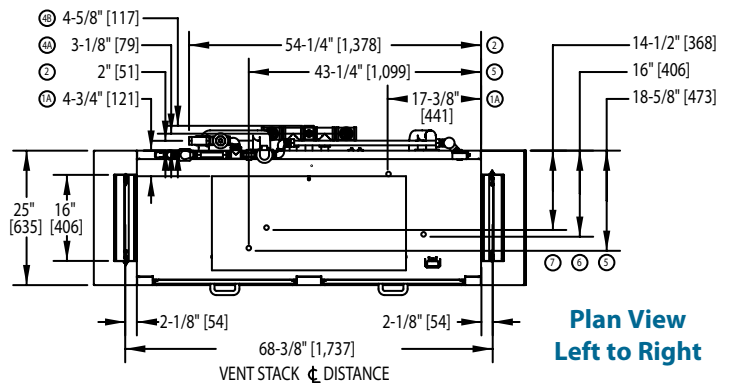
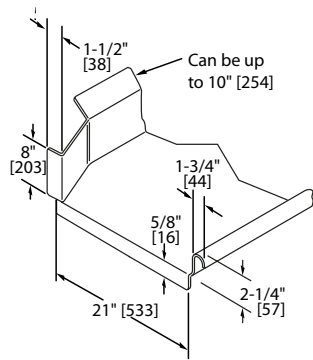
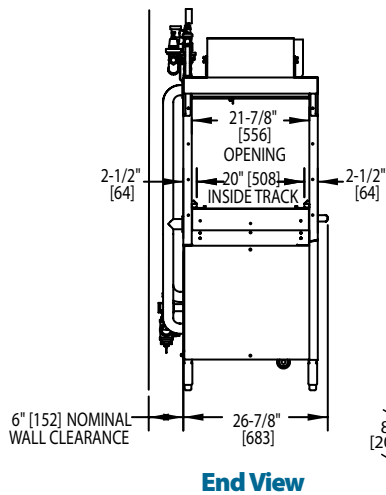
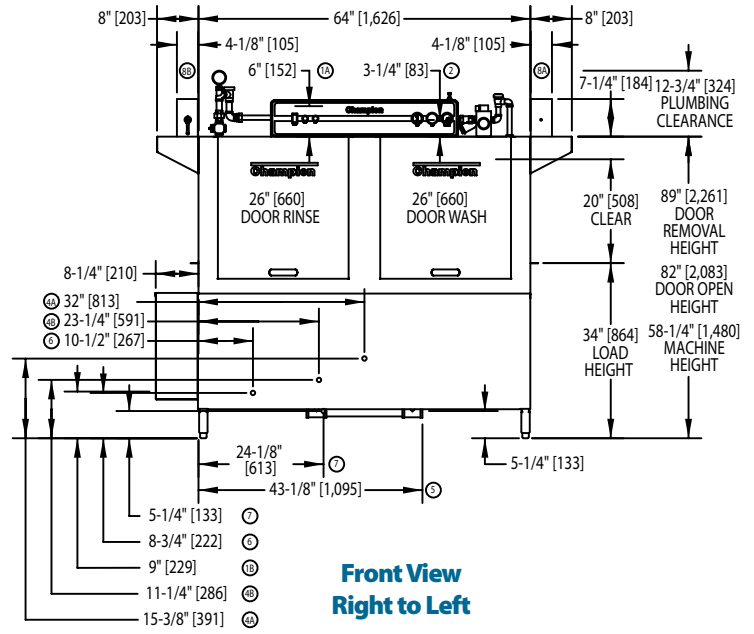
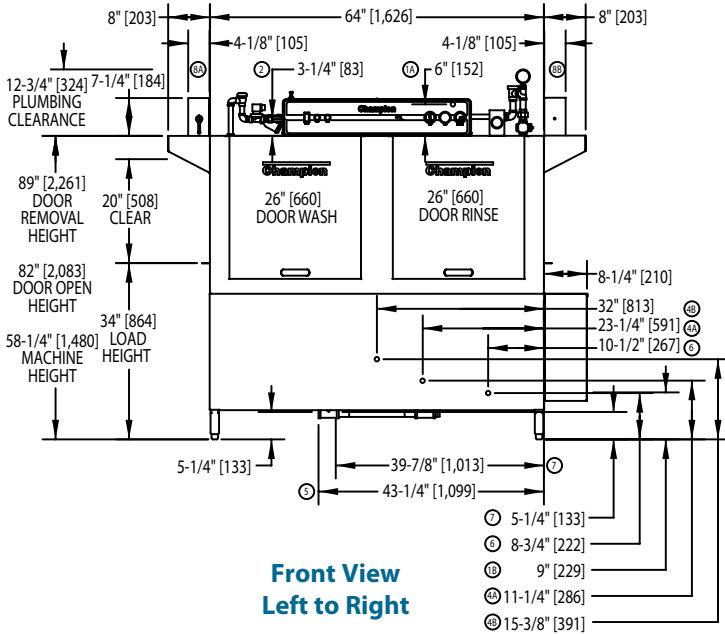

Due to an ongoing value analysis program at Champion, specifications contained in this catalog are subject to change without notice.

Champion Industries, Inc., 3765 Champion Blvd., Winston-Salem, NC 27105 • 336/661-1556 • Fax: 336/661-1979 • www.championindustries.com  
2674 N. Service Road, Jordan Station, Ontario, Canada L0R 1S0 • 905/562-4195 • Fax: 905/562-4618

# 64 SERIES

**64, 86 PW, 90 FFPW, 100 HDPW**  
 High-Temperature  
 Rack Conveyor Dishwashing Machine

**Champion<sup>®</sup>**  
 The Dishwashing Machine Specialists

Dimensions shown in inches [mm]

## MODEL 86 PW WITH 22" PREWASH

Shipping weight crated: **1375 lbs.**

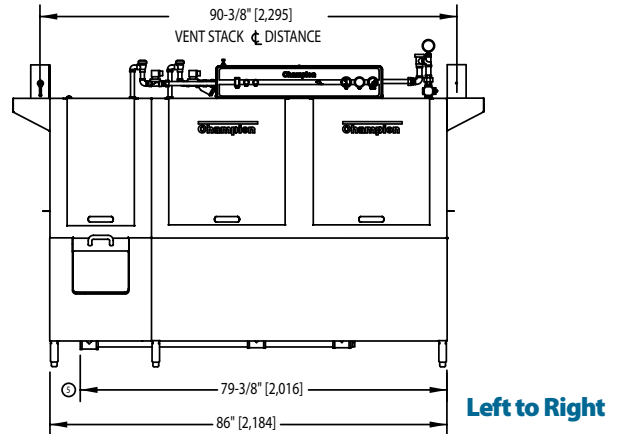
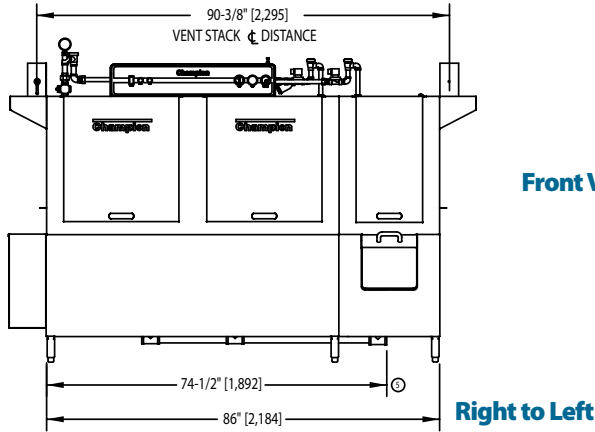

## MODEL 90 FFPW WITH 26" FRONT FEED PREWASH

Shipping weight crated: **1400 lbs.**

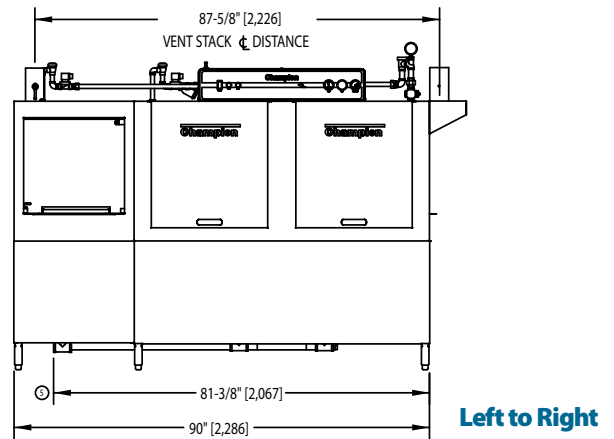
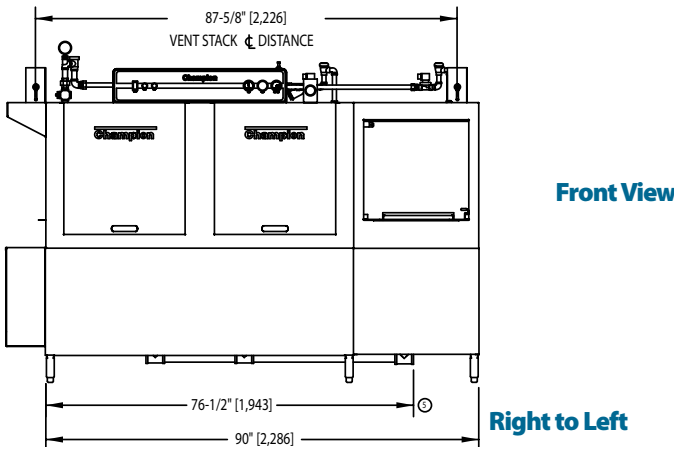

## MODEL 100 FFPW WITH 36" HEAVY DUTY PREWASH

Shipping weight crated: **1550 lbs.**

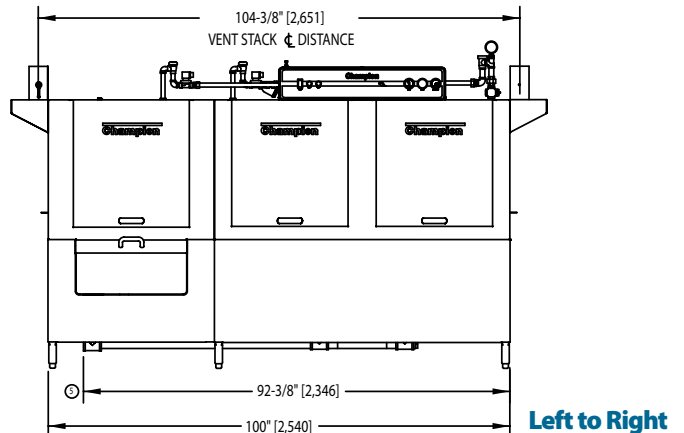
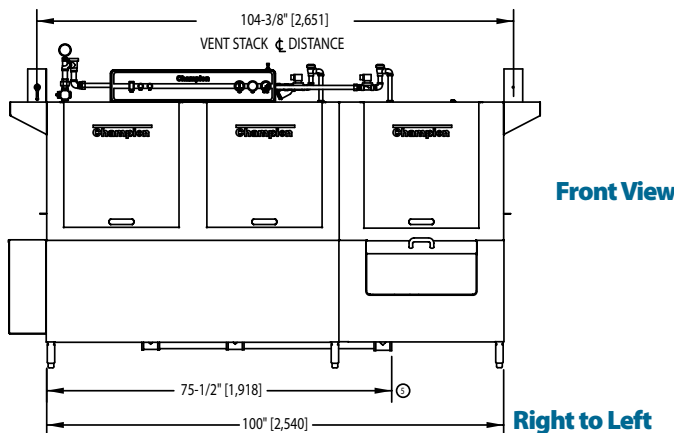

**NOTE:** For complete machine dimensions, plan view, end view, specifications and table construction see 64 drawing page.

# 64 SERIES

**64, 86 PW, 90 FFPW, 100 HDPW**  
High-Temperature  
Rack Conveyor Dishwashing Machine

# Champion®

The Dishwashing Machine Specialists

Dimensions shown in inches

Utilities	
<b>1</b>	<b>Electrical Connection</b> A Machine electrical connection B Booster electrical connection
<b>2</b>	<b>Hot Water</b> Main connection 3/4" NPT
<b>3</b>	<b>Cold Water</b> Contact Factory
<b>4</b>	<b>Hot Water Tank</b> A Heat inlet connection 1" NPT B Heat return connection 1" NPT
<b>5</b>	<b>Drain</b> Connection 1 1/2" NPT
<b>6</b>	<b>Steam</b> Inlet connection 1 1/4" NPT
<b>7</b>	<b>Condensate</b> Connection 1" NPT return to boiler
<b>8</b>	<b>Vents</b> A Stack connection - Load end 150 CFM @ 1/4" static pressure B Stack connection - Unload end 400 CFM @ 1/4" static pressure

**Warning:** Plumbing and electrical connections should be made by qualified personnel who will observe all the applicable plumbing, sanitary, safety codes and the National Electrical Code.

**Note:** Water Hammer Arrestor (meeting ASSE-1010 standard or equivalent) to be supplied (by others) in common water supply line at service connection.

**Plumbing Notes:** Because of the variation in house-supplied steam and water pressures, steam and water pressure regulating valves (PRVs) may be needed. (Water PRV is standard on machines with booster.) The PRVs can either be purchased from Champion or obtained locally.

**Venting Notes:** Fabricated duct size: 3-7/8" x 15-7/8" (Outside dimensions)

**64 ONLY**  
**TABLE A - Machine Connection**

Machine only			
Elec. Specs.	Rated Amps	Minimum Supply Ckt. Conductor Ampacity	Minimum Overcurrent Protective Device
208/60/3	90	110	110
240/60/3	80	100	100
480/60/3	40	50	50
575/60/3	31	40	40

**64 ONLY**  
**TABLE B - Booster Connection**

40°F/22°C Rise – 15 kW Electric built-in booster (booster only)			
Elec. Specs.	Rated Amps	Minimum Supply Ckt. Conductor Ampacity	Minimum Overcurrent Protective Device
208/60/3	42	50	50
240/60/3	36	45	45
480/60/3	18	25	25
575/60/3	15	20	20

70°F/39°C Rise – 24 kW Electric built-in booster (booster only)			
Elec. Specs.	Rated Amps	Minimum Supply Ckt. Conductor Ampacity	Minimum Overcurrent Protective Device
208/60/3	67	80	80
240/60/3	58	70	70
480/60/3	29	35	35
575/60/3	24	30	30

Machine and steam built-in booster			
Elec. Specs.	Rated Amps	Minimum Supply Ckt. Conductor Ampacity	Minimum Overcurrent Protective Device
208/60/3	15	20	20
240/60/3	14	20	20
480/60/3	7	15	15
575/60/3	6	15	15

**86 PW, 90 FFPW, 100 HDPW**  
**TABLE A - Machine Connection**

Machine only			
Elec. Specs.	Rated Amps	Minimum Supply Ckt. Conductor Ampacity	Minimum Overcurrent Protective Device
208/60/3	95	125	125
240/60/3	83	100	100
480/60/3	41	50	50
575/60/3	32	40	40

**86 PW, 90 FFPW, 100 HDPW**  
**TABLE B - Booster Connection**

40°F/22°C Rise – 15 kW Electric built-in booster (booster only)			
Elec. Specs.	Rated Amps	Minimum Supply Ckt. Conductor Ampacity	Minimum Overcurrent Protective Device
208/60/3	42	50	50
240/60/3	36	45	45
480/60/3	18	25	25
575/60/3	15	20	20

70°F/39°C Rise – 24 kW Electric built-in booster (booster only)			
Elec. Specs.	Rated Amps	Minimum Supply Ckt. Conductor Ampacity	Minimum Overcurrent Protective Device
208/60/3	67	80	80
240/60/3	58	70	70
480/60/3	29	35	35
575/60/3	24	30	30

Machine and steam built-in booster			
Elec. Specs.	Rated Amps	Minimum Supply Ckt. Conductor Ampacity	Minimum Overcurrent Protective Device
208/60/3	20	25	25
240/60/3	17	25	25
480/60/3	9	15	15

Contact factory for single phase information.

Due to an ongoing value analysis program at Champion, specifications contained in this catalog are subject to change without notice.

Champion Industries, Inc., 3765 Champion Blvd., Winston-Salem, NC 27105 • 336/661-1556 • Fax: 336/661-1979 • www.championindustries.com  
2674 N. Service Road, Jordan Station, Ontario, Canada L0R 1S0 • 905/562-4195 • Fax: 905/562-4618

# 64 SERIES

**64, 86 PW, 90 FFPW, 100 HDPW**

High-Temperature  
Rack Conveyor Dishwashing Machine

# Champion®

The Dishwashing Machine Specialists

## OPTIONS & ACCESSORIES

- Tank heat: choice of steam coil, steam injector, hot water coil
- 2 Hp prewash motor
- 48" Blower-dryer - steam or electric
- Booster Heaters (completely interplumbed, controls are interwired)
  - Steam: 40°F or 70°F rise
  - Electric: 15 kW (40°F rise) (built-in only)
  - Electric: 24 kW (70°F rise) (built-in only)
- Cantilever sideloader (with or without hood) for 90° load operation
  - 24" Sideload
  - 30" Sideload (accepts sheet pans)
- Extended pawl bar (extended drive unit) for use with load tabling
- Racks: peg or flat racks (specify type)
- Steam pressure regulating valve (unmounted)
- Table limit switch, unmounted (recommended on all rack conveyor installations)
- Vent cowl, stainless steel with 7" stack and locking damper
- Extended vent hood, stainless steel with 7" stack and locking damper
- Water pressure regulating valve (unmounted) (standard with booster)
- Water hammer kit
- Drain tempering kit
- Vertical clearance through machine: 24" (instead of standard 20") for larger ware
- Model CCT 180 (180° Corner Conveyor Table)
- Model CCT 90 (90° Corner Conveyor Table)
- Model RCT 64 or RCT 84 Roller Conveyor Table (See factory for custom length)
- Splash Shields



**NEW CCT 90**  
90° Corner Conveyor Table (shown)  
**NEW CCT 180**  
180° Corner Conveyor Table  
also available



**Cantilever Sideloader**  
(No hood)



**Model RCT 64  
or RCT 84**  
Roller  
Conveyor Table

Due to an ongoing value analysis program at Champion, specifications contained in this catalog are subject to change without notice.  
'USGBC' and related logo is a trademark owned by the U.S. Green Building Council and is used by permission.

Champion Industries, Inc., 3765 Champion Blvd., Winston-Salem, NC 27105 • 336/661-1556 • Fax: 336/661-1979 • www.championindustries.com  
2674 N. Service Road, Jordan Station, Ontario, Canada L0R 1S0 • 905/562-4195 • Fax: 905/562-4618