

MECHANICAL SPECIFICATIONS

MECHANICAL GENERAL PROVISIONS

- ELECTRICAL CONTRACTOR SHALL ACT AS AND SHALL BE CONSIDERED THE GENERAL CONTRACTOR FOR THIS PROJECT AND SHALL BE RESPONSIBLE FOR CONSTRUCTION COORDINATION, CONSTRUCTION MANAGEMENT, FINAL BALANCING AND COMMISSIONING, AND TAKES RESPONSIBILITY OF ALL WORK ON SITE. GENERAL CONTRACTOR SHALL CARRY COSTS OF COORDINATE, AND TAKE RESPONSIBILITY FOR ALL WORK AND EFFORT OF ALL SUB TRADES REQUIRED TO COMPLETE THE SCOPE OF WORK.
- CONTRACTOR TO BE IN ACCORDANCE WITH APPLICABLE PROVINCIAL BUILDING CODES, LEGISLATED STANDARDS, MOST RECENT VERSIONS OF REFERENCED DOCUMENTS IN CODES AND STANDARDS, AND TO GOOD TRADE PRACTICE.
- THE CONTRACTOR SHALL ASSUME RESPONSIBILITY FOR NEW EQUIPMENT INCLUDING COORDINATING DELIVERIES, TEMPORARY STORAGE UNTIL INSTALLATION, INSTALLATION OF EQUIPMENT AND WARRANTY.
- CONTRACTOR IS RESPONSIBLE FOR OWN SITE MEASUREMENTS AND INVESTIGATION BEFORE CONTRACT AWARD AND BEFORE COMMENCING CONSTRUCTION. CONTRACTOR IS RESPONSIBLE FOR NOTIFYING ENGINEER OF ANY DISCREPANCIES BETWEEN DRAWINGS AND SITE CONDITIONS.
- PAINTING; RESTORE TO NEW CONDITION FINISHES WHICH HAVE BEEN DAMAGED. APPLY ONE COAT OF CORROSION RESISTANT PRIMER PAINT TO FERROUS SUPPORTS AND SITE FABRICATED WORK.
- THE BUILDING IS TO BE OCCUPIED AND REMAIN IN USE DURING CONSTRUCTION. GENERAL CONTRACTOR SHALL COORDINATE ALL WORK SCHEDULING AND PHASING WITH THE NCC TO WORK AROUND THE OCCUPANTS' SCHEDULES AND REQUIREMENTS. REFER TO DRAWING ME-04 FOR ADDITIONAL DETAILS.
- GENERAL CONTRACTOR IS RESPONSIBLE FOR OBTAINING AND COORDINATING ALL NECESSARY HOT WORK PERMITS AND FIRE ALARM BY-PASSES AS REQUIRED TO COMPLETE THE SCOPE OF WORK.

SCOPE OF WORK

- PROVIDE LABOUR, EQUIPMENT AND SERVICES NECESSARY TO PROPERLY COMPLETE THE WORK INDICATED ON DRAWINGS.

PERMITS AND FEES

- OBTAIN AND PAY FOR PERMITS AND FEES NECESSARY FOR THE EXECUTION OF THE WORK. CONFORM TO ALL APPLICABLE CODES AND BY-LAWS. OBTAIN CERTIFICATES OF ACCEPTANCE FROM ALL THE INSPECTION AUTHORITIES.

SITE VISITS

- ACQUIRE FULL WORKING KNOWLEDGE OF BUILDING SITE AND ANY EXISTING CONDITIONS WHICH MAY AFFECT THE WORK. VISIT SITE PRIOR TO TENDER SUBMISSION.

PROTECTION

- TAKE PRECAUTIONS TO PROTECT THE OCCUPANTS AND BUILDING FROM INJURY OR DAMAGE DUE TO CONSTRUCTION ACTIVITIES.

CONTRACT DRAWINGS

- CONTRACT DRAWINGS FOR WORK ARE IN PART DIAGRAMMATIC, INTENDED TO CONVEY THE SCOPE OF WORK AND GENERAL ARRANGEMENT OF WORK COMPONENTS. BEFORE INSTALLATION, VERIFY THE PHYSICAL LOCATION OF ALL COMPONENTS WITH OTHER TRADES AND REPORT ANY OBSTRUCTIONS OR INTERFERENCES. NO EXTRA PAYMENTS ARISING FROM FAILURE TO MAKE THIS VERIFICATION WILL BE CONSIDERED.

EXISTING SERVICES

- GIVE THE OWNER AMPLE NOTICE OF EACH NECESSARY INTERRUPTION TO EXISTING SYSTEMS DURING THE COURSE OF THE WORK. KEEP THE DURATION OF INTERRUPTIONS AS SHORT AS POSSIBLE. THE OWNER RESERVES THE RIGHT TO DENY APPROVAL FOR AN INTERRUPTION ON ANY SPECIFIC DATE OR TIME. IN THIS CASE, AN ALTERNATIVE TIME SHALL BE MUTUALLY SELECTED.

CUTTING, PATCHING, AND PAINTING

- THE GENERAL CONTRACTOR SHALL CARRY COSTS OF, COORDINATE, AND TAKE RESPONSIBILITY FOR ALL WORK AND EFFORT OF ALL SUB TRADES REQUIRED FOR CUTTING, PATCHING, AND PAINTING.
- REMOVE ARCHITECTURAL FINISHES AND ELEMENTS AS REQUIRED TO ALLOW FOR THE DEMOLITION AND NEW WORK SHOWN ON ALL DRAWINGS.
- RESTORE AND FINISH ALL DAMAGED BUILDING ELEMENTS TO MATCH EXISTING.

DEMOLITION

- REMOVE FROM THE CONSTRUCTION SITE EXISTING EQUIPMENT WHICH BECOMES OBSOLETE AS A RESULT OF THE WORK EXCEPT AS OTHERWISE STATED.

WARRANTY

- WARRANTY ALL WORK FOR TWELVE (12) MONTHS FROM DATE OF ACCEPTANCE, EXCEPT WHERE NOTED OTHERWISE.

CONTRACT CLOSEOUT

- PROVIDE ONE SET OF MARKED UP RED LINE DRAWINGS SHOWING AS-BUILT CONFIGURATION OF ALL WORK.
- PROVIDE A ONE YEAR WARRANTY INCLUSIVE OF PARTS AND LABOUR FOR ALL WORK COVERED BY THIS CONTRACT.

SHOP DRAWINGS

- SUBMIT TO THE ENGINEER FOR APPROVAL ONE (1) COPY OF SHOP DRAWINGS FOR ALL NEW EQUIPMENT, PRODUCTS AND SYSTEMS (INCLUDING WIRING DIAGRAMS AND CONTROL SCHEMATICS).

MATERIALS

- MATERIALS AND EQUIPMENT TO BE NEW, UNLESS OTHERWISE INDICATED, AND FREE FROM DAMAGE, BLEMISHES, OXIDATION, ETC. MATERIALS USED FOR SIMILAR PURPOSES AND FUNCTIONS SHALL BE THE PRODUCT OF ONE MANUFACTURER UNLESS SPECIFIED OTHERWISE.

ACCESSORIES

- PROVIDE ACCESSORY ITEMS OR MATERIALS REQUIRED SUCH AS EQUIPMENT SUPPORTS, FABRICATED BASES, BRACKETS, CLEATS, CONNECTORS, SEALANTS, LUBRICANTS, CLEANERS, PROTECTIONS, ETC., TO ENSURE COMPLETE AND TOTALLY FUNCTIONAL SYSTEMS ARE PROVIDED TO THE OWNER.

CONTROLS

- NEW ELECTRIC BASEBOARD HEATERS TO BE CONTROLLED BY EXISTING OR NEW REMOTE LOW VOLTAGE THERMOSTATS, AND TRIAC SOLID STATE RELAY CONTROLLERS SUPPLIED AND INSTALLED BY THE CONTROLS CONTRACTOR. LOW VOLTAGE WIRING AND INTERFACING WITH EXISTING BUILDING AUTOMATION SYSTEM BY THE CONTROLS CONTRACTOR. LINE VOLTAGE WIRING SHALL BY THE ELECTRICAL CONTRACTOR. REFER TO DRAWING ME-04.
- NEW FORCE FLOW HEATERS TO BE CONTROLLED BY NEW REMOTE LOW VOLTAGE THERMOSTATS, SUPPLIED AND INSTALLED BY THE CONTROLS CONTRACTOR. 24V RELAY AND CONTACTOR INTEGRAL TO FORCE FLOW HEATERS. LOW VOLTAGE WIRING BY THE CONTROLS CONTRACTOR. LINE VOLTAGE WIRING BY ELECTRICAL CONTRACTOR. REFER TO DRAWING ME-04.
- NEW UNIT HEATERS TO BE CONTROLLED BY NEW REMOTE LOW VOLTAGE THERMOSTATS, SUPPLIED AND INSTALLED BY THE CONTROLS CONTRACTOR. 24V RELAY AND CONTACTOR INTEGRAL TO FORCE FLOW HEATERS. LOW VOLTAGE WIRING BY THE CONTROLS CONTRACTOR. LINE VOLTAGE WIRING BY ELECTRICAL CONTRACTOR. REFER TO DRAWING ME-04.
- TRIAc SOLID STATE RELAY CONTROLLERS:
 - PROVIDES ON-OFF CONTROL ON ELECTRICAL RESISTANCE LOAD.
 - MODULATES POWER NEAREST TO DEMAND AND REDUCES ENERGY COST AND POWER CONSUMPTION.
 - ZERO-CROSSING OPERATION, ELIMINATES THE THERMAL SHOCKS OVERSHOOT AND UNDERSHOOT.
 - CYCLE ONCE PER SECOND, VERY FAST AND QUIET.
 - LIFE EXPECTATION HIGHER THAN 1 000 000 000 OPERATIONS.
 - DOES NOT CREATE RFI (RADIO FREQUENCY INTERFERENCE) AND WILL NOT ADVERSELY AFFECT SENSITIVE EQUIPMENT.
 - EPOXY THERMALLY PROTECTED, FOR HUMIDITY, PROTECTION, OVERHEAT OR CONTAMINATED ENVIRONMENT.
 - MOUNTED ON AN ALUMINIUM HEAT SINK AND THE ELECTRONIC COMPONENTS ARE COVERED IN A THERMAL EPOXY.
 - ACCEPT INPUT SIGNAL: 24 VAC, 24 VDC, 3-32 VDC.
 - OUTPUT: 48 TO 600 VAC, 1 PHASE.
 - AMPERAGE: 45 A.
 - SECURITY FACTORY 2, I.E. 600 VOLTS SURGE PROTECTED AND BUILT FOR 1200 VOLTS.
 - CSA AND C US APPROVED.
 - 2 YEAR WARRANTY.
 - ACCEPTABLE PRODUCT: REGULVAR MODEL SSR600-C4, OR APPROVED ALTERNATE.
- LOW VOLTAGE THERMOSTATS:
 - TYPE: LOW VOLTAGE ELECTRONIC THERMOSTAT.
 - COMPATIBLE WITH ELECTROMECHANICAL AND ELECTRONIC RELAYS.
 - COLOR: STANDARD: WHITE.
 - VOLTAGE: 24V.
 - TEMPERATURE SETTING RECORDED PERMANENTLY.
 - CONTROL: RESOLUTION: 0.5 °C (1 °F). 15-MINUTE CYCLES. "ON/STANDBY" SWITCH: ALLOWS TO PUT THE THERMOSTAT IN STANDBY MODE WHEN IT IS NOT IN USE (DURING SUMMER FOR EXAMPLE).
 - DISPLAY: DIGITAL DISPLAY OF AMBIENT TEMPERATURE (°C OR °F), HEATING LEVEL INDICATOR AND SETPOINT TEMPERATURE. BACKLIT.
 - TEMPERATURE RANGE: 5 °C (40 °F) TO 30 °C (86 °F).
 - THERMOSTATS LOCATED IN PUBLIC AREAS TO BE SUPPLIED WITH PLASTIC TAMPERPROOF GUARDS, KEYED ALIKE, TO MATCH EXISTING INSTALLATION: 3-WIRE THERMOSTAT.
 - WARRANTY: 1-YEAR WARRANTY AGAINST DEFECTS.
 - ACCEPTABLE PRODUCT: OUELLET SERIES OTH824, OR APPROVED ALTERNATE.
 - WIRED TO RELAYS INTEGRAL TO NEW HEATERS. REFER TO ELECTRICAL.
- REFER TO DRAWING ME-03 AND ME-04 FOR CONTROLS WORK.

ABATEMENT REQUIREMENTS FOR ALL CONTRACTORS

HAZARDOUS MATERIALS

CONTRACTOR TO READ ASBESTOS REPORT PREPARED BY TROW DATED FEBRUARY 2010 PROVIDED BY THE NCC AND ATTACHED TO FRONT END DOCUMENTS OF THIS PROJECT. CONTRACTOR TO CARRY THE COST TO COMPLETE ALL ABATEMENT WORK OUTLINED/SPECIFIED IN REPORT IN AREAS AFFECTED BY THIS PROJECT. THIS REPORT IS PART OF THIS CONTRACT AND TO BE READ IN CONJUNCTION WITH DEMOLITION DOCUMENTS.

ASBESTOS ABATEMENT SUBMITTALS

- ALL WORK TO BE COMPLETED UNDER THE DIRECTION OF CONTRACTOR'S ENVIRONMENTAL CONSULTANT AND ASBESTOS ABATEMENT SPECIALIST INCLUDING ABATEMENT PLAN, REMOVAL AND FINAL INSPECTIONS. ALL ABATEMENT PLANS AND INSPECTION REPORTS AS WELL AS FINAL AIR TESTING TO BE SUBMITTED TO THE NCC
 - OBTAIN FROM APPROPRIATE AGENCY AND SUBMIT TO THE NCC NECESSARY PERMITS FOR TRANSPORTATION AND DISPOSAL OF ASBESTOS WASTE. ENSURE THAT DUMP OPERATOR IS FULLY AWARE OF HAZARDOUS NATURE OF MATERIAL BEING DUMPED AND PROPER METHODS OF DISPOSAL. SUBMIT PROOF SATISFACTORY TO THE NCC THAT SUITABLE ARRANGEMENTS HAVE BEEN MADE TO RECEIVE AND PROPERLY DISPOSE OF ASBESTOS WASTE.
 - SUBMIT PROOF SATISFACTORY TO THE NCC THAT ALL ASBESTOS WORKERS HAVE RECEIVED APPROPRIATE TRAINING AND EDUCATION BY A COMPETENT PERSON ON HAZARDS OF ASBESTOS EXPOSURE, GOOD PERSONAL HYGIENE, ENTRY AND EXIT FROM ASBESTOS WORK AREA, ASPECTS OF WORK PROCEDURES AND PROTECTIVE MEASURES WHILE WORKING IN ASBESTOS WORK AREAS, AND THE USE, CLEANING AND DISPOSAL OF RESPIRATORS AND PROTECTIVE CLOTHING. SUBMIT PROOF OF ATTENDANCE IN FORM OF CERTIFICATE.
 - ENSURE SUPERVISORY PERSONNEL HAVE ATTENDED ASBESTOS ABATEMENT COURSE, OF NOT LESS THAN TWO DAYS DURATION, APPROVED BY THE NCC. SUBMIT PROOF OF ATTENDANCE IN FORM OF CERTIFICATE. MINIMUM OF ONE SUPERVISOR FOR EVERY TEN WORKERS.
 - SUBMIT LAYOUT OF PROPOSED ENCLOSURES, PROCEDURES AND DECONTAMINATION FACILITIES AS REQUIRED AS WELL ALL GENERAL ABATEMENT PLAN PRODUCED BY CONTRACTOR'S ABATEMENT SPECIALIST TO THE NCC FOR REVIEW.
- BEFORE BEGINNING WORK:
 - GENIVAR SHALL NOT BE RESPONSIBLE FOR AND/OR INVOLVED IN THE COORDINATION, IMPLEMENTATION, SUPERVISION, AND/OR REVIEW OF ANY OF THE ASBESTOS ABATEMENT WORK REQUIRED FOR THIS PROJECT AS OUTLINED IN THE TROW REPORT.

ASBESTOS ABATEMENT

- ALL ASBESTOS DISPOSAL TO BE DONE IN ACCORDANCE WITH APPLICABLE LEGISLATION AND AS DIRECTED BY CONTRACTOR'S ENVIRONMENTAL CONSULTANT AND ASBESTOS ABATEMENT SPECIALIST.
- PLACE MATERIALS DEFINED AS HAZARDOUS OR TOXIC IN DESIGNATED CONTAINERS.
- HANDLE AND DISPOSE OF HAZARDOUS MATERIALS IN ACCORDANCE WITH THE CEPA, TDGA, REGIONAL AND MUNICIPAL REGULATIONS.
- DISPOSAL OF ASBESTOS WASTE GENERATED BY REMOVAL ACTIVITIES MUST COMPLY WITH FEDERAL, PROVINCIAL, TERRITORIAL AND MUNICIPAL REGULATIONS. DISPOSE OF ASBESTOS WASTE IN SEALED DOUBLE THICKNESS 6 ML BAGS OR LEAK PROOF DRUMS. LABEL CONTAINERS WITH APPROPRIATE WARNING LABELS.
- PROVIDE MANIFESTS DESCRIBING AND LISTING WASTE CREATED. TRANSPORT CONTAINERS BY APPROVED MEANS TO LICENSED LANDFILL FOR BURIAL.

ABBREVIATIONS:

- UVV. VAV TERMINAL UNIT
- TP. LOW VOLTAGE ROOM THERMOSTAT
- V. 2-WAY VALVE C/W ACTUATOR
- S. TEMPERATURE SENSOR. (THERMISTOR) INSTALLED INSIDE ROOM THERMOSTAT CASING, WIRED TO BAS.

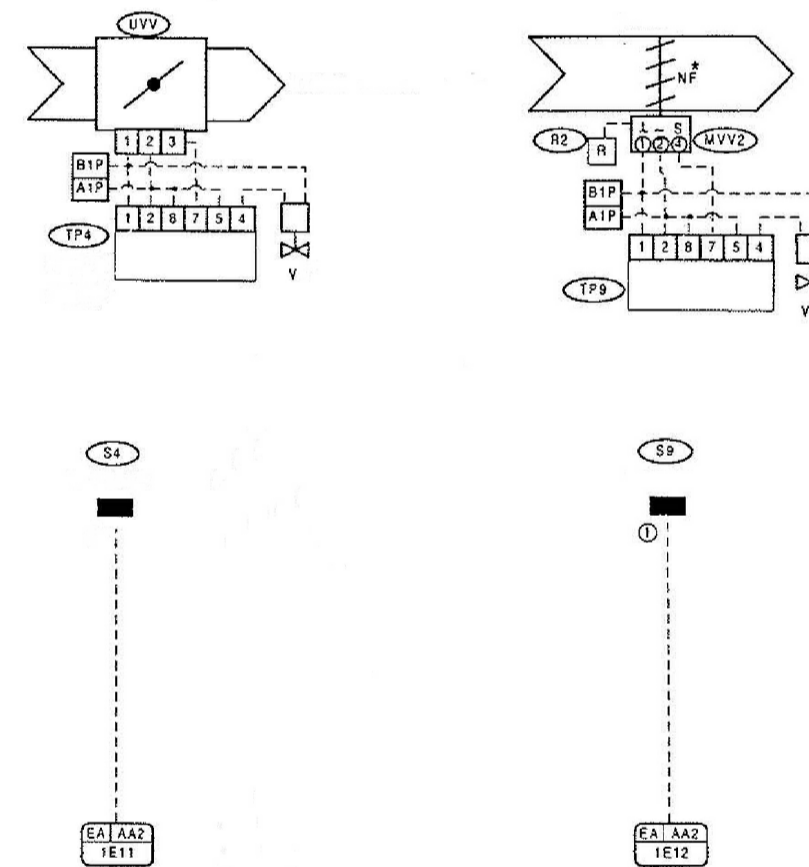

1 TYPICAL EXISTING TERMINAL UNIT / HYDRONIC HEATING VALVE "BAS" CONTROLS DIAGRAM

MECHANICAL LEGEND	
ITEM	DESCRIPTION
—HWS—	HEATING WATER SUPPLY
—HWR—	HEATING WATER RETURN
	EXISTING PUMP TO BE REMOVED
—W—	DIRECTION OF AIR FLOW
G-----	PIPE DOWN TO BE REMOVED
O-----	PIPE UP TO BE REMOVED
	CONTROL VALVE TO BE REMOVED
	ISOLATION VALVE TO BE REMOVED
	EXPANSION TANK TO BE REMOVED
	UNIT HEATER TO BE REMOVED
	ELECTRIC BOILER TO BE REMOVED
	HYDRONIC HEATER TO BE REMOVED
	EXISTING DISCONNECT SWITCH TO BE REMOVED
	DEMOLISH/REMOVE EXISTING
	DRAWING NOTE No. 1
	LOW VOLTAGE WIRING (BY CONTROLS CONTRACTOR)
	LOW VOLTAGE THERMOSTAT (BY CONTROLS CONTRACTOR)
	ROOM TEMPERATURE SENSOR



Capital Planning and Real Asset Management Branch
Direction de l'aménagement de la capitale et gestion de l'immobilier

Design and Construction Division
Division design et construction

director - Daniel Miron - directeur

consultant
expert-conseil



issued or revised émis ou révisé		
no.	description	date
2	ISSUED FOR TENDER	2013-06-07
1	ISSUED FOR 100%	2013-03-28

project
HEATING SYSTEM
UPGRADES - GATINEAU PARK
VISITORS' CENTER
CENTRE DES VISITEURS DU
PARC DE LA GATINEAU
MODIFICATIONS AU SYSTÈME
DE CHAUFFAGE

drawing
dessin

MECHANICAL
LEGEND, SPECIFICATIONS,
CONTROLS DIAGRAM

approved by approuvé par	P.C.
designed by conçu par	G.S.
drawn by dessiné par	M.A.D.
date	MARCH 2013
scale	AS SHOWN
NCC project no. no. du projet de la CCN	DC3020-5
sheet no. no. de la feuille	ME-01

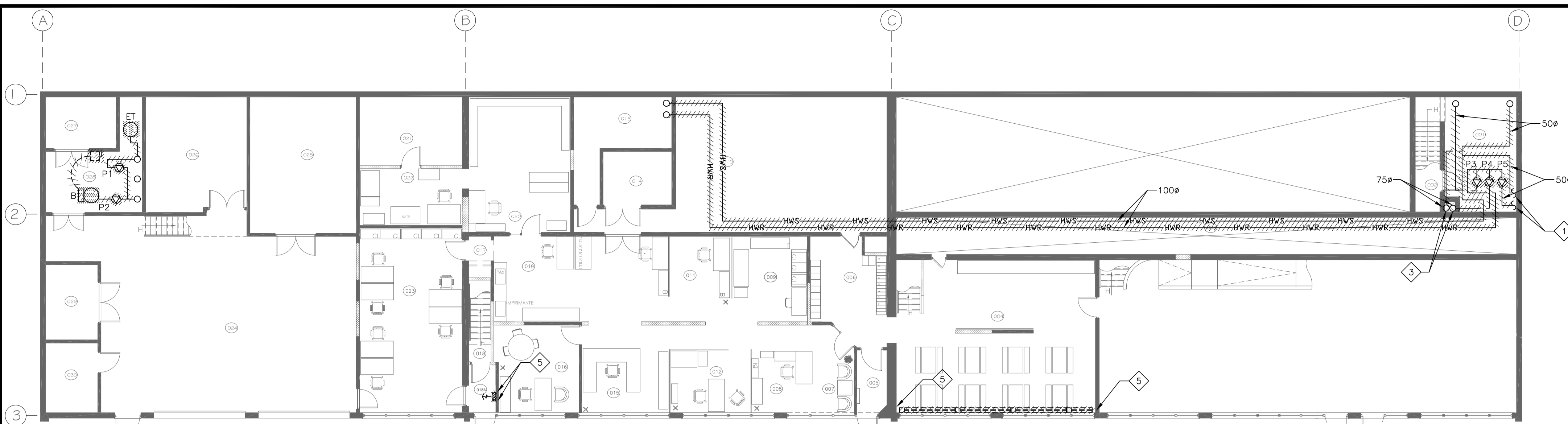

A LOWER FLOOR LEVEL - DEMOLITION WORK
ME-02
3/32" = 1'-0"
0 3' 6' 12' 18' 24' 30'

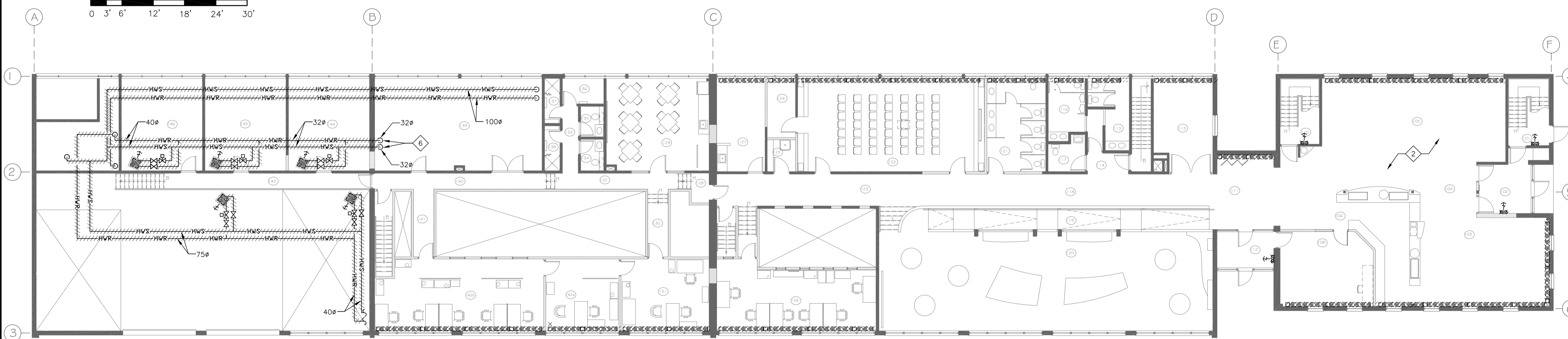

B MAIN FLOOR LEVEL - DEMOLITION WORK
ME-02
3/32" = 1'-0"
0 3' 6' 12' 18' 24' 30'

GENERAL NOTES:

- A. MECHANICAL CONTRACTOR TO REMOVE THE EXISTING HYDRONIC HEATING SYSTEM IN ITS ENTIRETY, UNLESS NOTED OTHERWISE. REMOVE ALL MECHANICAL AND ELECTRICAL ELEMENTS INCLUDING ALL PIPING, INSULATION, SUPPORTS, VALVES, FITTINGS, CONDUIT, WIRING, COMPONENTS, ETC. WHETHER EXPLICITLY SHOWN ON DRAWINGS OR NOT, UNLESS NOTED OTHERWISE.
- B. EXISTING THERMOSTATS AND CONTROL WIRING TO REMAIN FOR RECONNECTION TO NEW ELECTRIC HEATERS.
- C. THE NEW ELECTRIC HEATER SIZES MAY DIFFER FROM THE EXISTING HYDRONIC HEATER SIZES. PATCH, PAINT, AND FINISH BEHIND REMOVED HEATERS AS REQUIRED.
- D. ELECTRICAL CONTRACTOR TO DISCONNECT AND REMOVE ALL ELECTRICAL TO HYDRONIC HEATING SYSTEM EQUIPMENT BEING REMOVED SUCH AS THE BOILER, PUMPS, FAN-POWERED UNIT-HEATERS AND CONSOLE HEATERS. ELECTRICAL CONDUIT AND WIRING TO BE REMOVED BACK TO ASSOCIATED PANEL BREAKER AND LABELLED AS "SPARE" AT PANEL DIRECTORY. WHERE A PORTION OF CONDUIT IS CONSIDERED INACCESSIBLE, THE PORTION OF CONDUIT IS TO REMAIN ABANDONED AND ITS WIRING IS TO BE REMOVED THROUGHOUT.
- E. FOR OCCUPIED SPACES: IF THE REMOVAL OF CONCEALED PIPING REQUIRES CUTTING AND PATCHING OF WALLS OR SLAB, THEN ABANDON THE PIPING WITHIN THE WALL/SLAB. CUT PIPING AT WALL/SLAB AND CAP AND PATCH OVER IT.
- F. ALL NEW MECHANICAL SYSTEMS INDICATED ARE TO BE COMPLETE, FULLY TESTED AND OPERATIONAL, MEETING THE REQUIREMENTS DESCRIBED IN THE CONTRACT DOCUMENTS AND IN COMPLETE ACCORDANCE WITH APPLICABLE CODES AND REGULATIONS.
- G. CONTRACT DRAWINGS ARE PARTLY DIAGRAMMATIC AND APPROXIMATE TO SCALE UNLESS DETAILED OTHERWISE. THE DRAWINGS ARE INTENDED TO ESTABLISH THE SCOPE OF WORK, QUALITY OF MATERIALS AND INSTALLATION, AND NOT DETAILED INSTALLATION INSTRUCTIONS. IT IS THE INSTALLING CONTRACTORS' RESPONSIBILITY TO ENSURE THAT EQUIPMENT MADE BY THE CHOSEN MANUFACTURERS WILL FIT WITHOUT CAUSING INTERFERENCE OR ACCESSIBILITY PROBLEMS.
- H. FOLLOW THE MANUFACTURERS' RECOMMENDATIONS REGARDING EQUIPMENT INSTALLATION, AND INCLUDE ALL ACCESSORIES AND FEATURES TO RESULT IN FULLY OPERATIONAL SYSTEMS.
- I. EQUIPMENT AND MATERIALS ARE TO BE INSTALLED GENERALLY IN LOCATIONS INDICATED ON THE DRAWINGS. COORDINATE THE LOCATIONS OF SERVICES AND EQUIPMENT WITH ALL OTHER TRADES AND SUB-TRADES TO AVOID CONFLICTS, INTERFERENCES, AND THE INEFFICIENT USE OF AVAILABLE SPACE.
- J. CONSULT WITH ALL OTHER TRADES AND SUB-TRADES INVOLVED ON THE PROJECT.
- K. INSTALL WORK TO ALLOW FOR EASY ACCESS FOR MAINTENANCE AND REPAIR.
- L. INSTALLING CONTRACTOR TO PROVIDE ACCESS PANELS AND DOORS WHERE NECESSARY TO GAIN ACCESS TO CONCEALED CONTROLS COMPONENTS, ETC.
- M. PROVIDE FIRE-STOPPING AT ALL LOCATIONS WHERE PIPES OR CONDUITS PENETRATE DESIGNATED FIRE AND SMOKE SEPARATIONS. FIRE STOPPING MATERIALS SHALL MEET THE REQUIREMENTS OF ULC CAN S115.
- N. THE INSTALLING CONTRACTORS ARE TO GROUT, CAULK, AND SEAL ALL BUILDING ENVELOPE PENETRATIONS MADE BY MECHANICAL SERVICES.
- O. FURNITURE AND DISPLAY CASES OBSTRUCTING THE WORK WILL BE MOVED AND PROTECTED WITH TARPS BY THE GENERAL CONTRACTOR. AFTER THE WORK IS DONE, THE FURNITURE AND DISPLAY CASES SHALL BE CLEANED AND RE-INSTALLED BY THE GENERAL CONTRACTOR. THE GENERAL CONTRACTOR SHALL MODIFY THE FURNITURE AND DISPLAY CASES, AS REQUIRED, TO SUIT THE NEW BASEBOARD HEATERS.

DRAWING NOTES:

- 1 CONCEALED PIPES SERVE ZONE INDICATED BY DRAWING NOTE #2. CONTRACTOR TO INVESTIGATE AND TRACE EXACT ROUTING OF CONCEALED PIPES AND REMOVE. DEMOLISH EXISTING ARCHITECTURAL ELEMENTS AS REQUIRED TO TRACE AND REMOVE PIPING.
- 2 ZONE SERVED BY PIPES INDICATED BY DRAWING NOTE #1.
- 3 CONCEALED PIPES RUN UP INTO SHAFT AND SERVE ZONE INDICATED BY DRAWING NOTE #4. CONCEALED PIPES ARE TO REMAIN. CAP PIPES AT POINT OF ENTRY INTO SHAFT.
- 4 ZONE SERVED BY PIPES INDICATED BY DRAWING NOTE #3.
- 5 HEATING WATER PIPE RISER CONCEALED WITHIN WALL TO BE REMOVED.
- 6 HWS AND HWR PIPES DROP BENEATH FLOOR BUT DO NOT APPEAR TO FURTHER SERVE ANY EXISTING EQUIPMENT IN THE BUILDING. CONTRACTOR TO INVESTIGATE AND TRACE EXACT ROUTING OF CONCEALED PIPE AND REMOVE. DEMOLISH EXISTING ARCHITECTURAL ELEMENTS AS REQUIRED TO TRACE AND REMOVE PIPING.

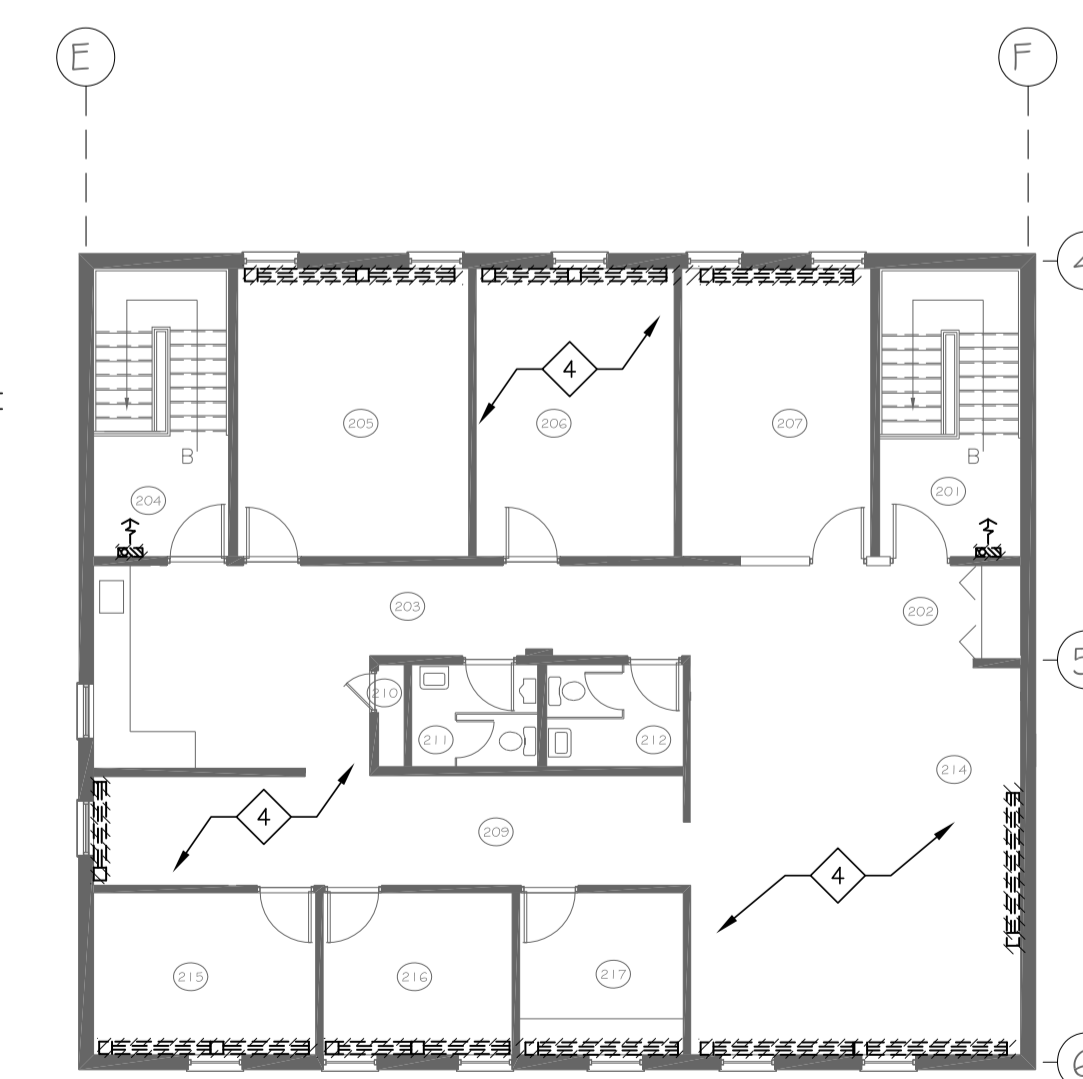

C SECOND FLOOR LEVEL - DEMOLITION WORK
ME-02
3/32" = 1'-0"
0 3' 6' 12' 18' 24' 30'

no.	description	date
2	ISSUED FOR TENDER	2013-06-07
1	ISSUED FOR 100%	2013-03-28

project
project **HEATING SYSTEM
UPGRADES - GATINEAU PARK
VISITORS' CENTER
CENTRE DES VISITEURS DU
PARC DE LA GATINEAU
MODIFICATIONS AU SYSTÈME
DE CHAUFFAGE**

drawing
dessin
**MECHANICAL/ELECTRICAL
FLOOR PLANS - DEMOLITION WORK**

approved by approuvé par	P.C.
designed by conçu par	G.S.
drawn by dessiné par	M.A.D.
date	MARCH 2013
scale échelle	AS SHOWN
NCC project no. no. du projet de la CCN	sheet no. no. de la feuille
DC3020-5	ME-02

ELECTRICAL SYMBOL LEGEND

NOTE: THIS A COMPREHENSIVE LEGEND AND NOT ALL ITEMS APPEAR ON THESE DRAWINGS.

SINGLE LINE DIAGRAM

SINGLE LINE SYMBOLS

- FUSE
- SWITCH
- FUSED DISCONNECT SWITCH
- METER SOCKET
- PANEL (REFER TO PANEL DETAIL)

POWER and DISTRIBUTION

DEVICE

- PANEL
- NON-FUSIBLE DISCONNECT
- FUSIBLE DISCONNECT
- ELECTRIC BASEBOARD HEATER
- ELECTRIC FORCED FLOW HEATER.
- ELECTRIC UNIT HEATER.
- EXISTING
- REPLACE WITH NEW
- REMOVE
- LOW VOLTAGE WIRING (BY CONTROLS CONTRACTOR)
- 600V, 1ph TRIAC (BY CONTROLS CONTRACTOR)
- LOW VOLTAGE THERMOSTAT (BY CONTROLS CONTRACTOR)
- ROOM TEMPERATURE SENSOR

NOTE:
REFER TO DRAWING ME-02 FOR ELECTRICAL DEMOLITION WORK ASSOCIATED WITH REMOVAL OF HOT WATER HEATING SYSTEM.

ELECTRICAL SPECIFICATION

GENERAL PROVISIONS

GENERAL CONDITIONS

THE ELECTRICAL CONTRACTOR SHALL ACT AS AND SHALL BE CONSIDERED THE GENERAL CONTRACTOR FOR THIS PROJECT AND SHALL BE RESPONSIBLE FOR CONSTRUCTION COORDINATION, CONSTRUCTION MANAGEMENT, FINAL BALANCING AND COMMISSIONING, AND TAKES RESPONSIBILITY OF ALL WORK ON SITE. GENERAL CONTRACTOR SHALL CARRY COSTS OF, COORDINATE, AND TAKE RESPONSIBILITY FOR ALL WORK AND EFFORT OF ALL SUB TRADES REQUIRED TO COMPLETE THE SCOPE OF WORK.

THE CONTRACTOR SHALL ASSUME RESPONSIBILITY FOR NEW EQUIPMENT INCLUDING COORDINATING DELIVERIES, TEMPORARY STORAGE UNTIL INSTALLATION, INSTALLATION OF EQUIPMENT AND WARRANTY.

THE BUILDING IS TO BE OCCUPIED AND REMAIN IN USE DURING CONSTRUCTION. GENERAL CONTRACTOR SHALL COORDINATE ALL WORK SCHEDULING AND PHASING WITH THE NCC TO WORK AROUND THE OCCUPANTS' SCHEDULES AND REQUIREMENTS. REFER TO DRAWINGS FOR ADDITIONAL DETAILS.

CONTRACTOR IS RESPONSIBLE FOR OBTAINING AND COORDINATING ALL NECESSARY HOT WORK PERMITS AND FIRE ALARM BYPASSES AS REQUIRED TO COMPLETE THE SCOPE OF WORK.

PROVIDE FOR ALL GENERAL CONDITIONS. PROVIDE ALL LABOUR, MATERIALS, PRODUCTS, EQUIPMENT, SERVICES AND ALL INCIDENTALS REQUIRED TO COMPLETE, TEST AND COMMISSION ALL ELECTRICAL WORK SHOWN ON THE DRAWINGS AND/OR NOTED HEREUNDER.

ALL WORK SHALL BE COMPLIMENTARY TO THE ORIGINAL BUILDING DESIGN AND INSTALLATIONS. WHERE AN EXACT METHOD OF INSTALLATION HAS NOT BEEN INDICATED, FOLLOW THE METHODS USED ON THE ORIGINAL BUILDING. GENERALLY, THE STANDARD OF WORK SHALL BE EQUAL TO OR BETTER THAN THAT OF THE ORIGINAL BUILDING. ADDITIONS AND/OR CHANGES TO EXISTING SYSTEMS SHALL BE MADE USING EQUIPMENT IDENTICAL TO THAT ALREADY USED IN THE BUILDING, UNLESS SPECIFICALLY INDICATED OTHERWISE.

ELECTRICAL WORK SHALL BE CARRIED OUT BY A CONTRACTOR HOLDING A VALID CONTRACTOR'S LICENSE AND QUALIFIED ELECTRICIANS WHO HOLD VALID QUEBEC CERTIFICATES OF QUALIFICATION FROM CORPORATION DES MAITRES ELECTRICIENS DU QUEBEC (CMEQ) AND THE RÈGIE DU BATIMENT DU QUEBEC (RBQ).

DEFINITIONS

"PROVIDE" MEANS SUPPLY AND INSTALL.
"APPROVAL" MEANS APPROVAL IN WRITING FROM THE OWNER & CONSULTANT OR AUTHORITIES HAVING JURISDICTION.
"CONSULTANT" MEANS THE ENGINEER OR THE CONSULTING ENGINEERING FIRM.
"OWNER" MEANS THE OWNER'S PROJECT MANAGER OR REPRESENTATIVE.

CODES AND STANDARDS

DO COMPLETE INSTALLATION IN ACCORDANCE WITH APPLICABLE CODES, INCLUDING BUT NOT NECESSARILY LIMITED TO THE QUEBEC ELECTRICAL CODE 2010 AND THE REQUIREMENTS OF ALL AUTHORITIES HAVING JURISDICTION.

PERMITS AND FEES

OBTAIN PERMITS NECESSARY FOR THE EXECUTION OF THE ELECTRICAL WORK. ON COMPLETION OF THE WORK FURNISH COPIES OF THE CERTIFICATES OF ACCEPTANCE FROM THE INSPECTION AUTHORITY AND PERTINENT AUTHORITIES HAVING JURISDICTION. PAY ALL ASSOCIATED COSTS AND FEES, INCLUDING ANY PREMIUMS ASSOCIATED WITH WORK SCHEDULE.

WARRANTY

WARRANTEE ALL WORK, MATERIALS, EQUIPMENT AND INSTALLATIONS TO BE FREE OF ALL DEFECTS, FOR 12 MONTHS FROM DATE OF ACCEPTANCE BY THE OWNER OR OWNER'S REPRESENTATIVE.

SITE VISIT

ACQUIRE FULL WORKING KNOWLEDGE OF BUILDING SITE AND ANY EXISTING CONDITIONS WHICH MAY AFFECT THE WORK. VISIT SITE PRIOR TO TENDER SUBMISSION.

CONTRACT DRAWINGS

CONTRACT DRAWINGS FOR ELECTRICAL WORK, ARE IN PART DIAGRAMMATIC, INTENDED TO CONVEY THE SCOPE OF WORK AND GENERAL ARRANGEMENT OF EQUIPMENT, CONDUIT AND OUTLETS. BEFORE INSTALLATION, VERIFY THE PHYSICAL LOCATION OF ALL ELECTRICAL EQUIPMENT WITH ALL OTHER INSTALLATIONS AND REPORT ANY OBSTRUCTIONS OR INTERFERENCES. NO EXTRA PAYMENTS ARISING FROM FAILURE TO MAKE THIS VERIFICATION WILL BE CONSIDERED.

DRAWINGS INDICATE THE GENERAL LAYOUT OF THE COMPLETE ELECTRICAL SYSTEM, ARRANGEMENT OF FEEDERS, CIRCUITS, CONTROLS, PANELBOARDS AND OTHER WORK.

THE DRAWINGS INDICATE THE GENERAL LOCATION AND ROUTES TO BE FOLLOWED, BUT DO NOT SHOW ALL CONDUIT AND/OR WIRING OR ALL THE STRUCTURAL, MECHANICAL AND ARCHITECTURAL DETAILS. PLAN AND INSTALL CONDUIT RUNS RESPECTING ALL APPLICABLE CONDITIONS INCLUDING STRUCTURAL, ARCHITECTURAL AND MECHANICAL DETAILS. BRING OBVIOUS DISCREPANCIES OR OMISSIONS TO THE ATTENTION OF THE CONSULTANT DURING THE TENDER PERIOD, AT LEAST FIVE WORKING DAYS PRIOR TO TENDER CLOSING.

SHOP DRAWINGS

SUBMIT ELECTRONIC VERSION OF SHOP DRAWINGS TO THE CONSULTANT WITH TRANSMITTAL FOR REVIEW OR AS REQUIRED BY THE GENERAL CONDITIONS. CLEARLY INDICATED THE PROJECT NAME AND PROVIDE ELECTRICAL CONTRACTOR STAMP. REVIEW OF SHOP DRAWINGS INDICATES ONLY THAT THE QUALITY AND GENERAL DESIGN OF THE EQUIPMENT IS ACCEPTABLE. VERIFICATION OF DETAILED DESIGN COMPLIANCE, DIMENSIONS AND QUANTITIES, OR THE LOCATION OF CONNECTIONS TO EQUIPMENT, SHALL BE THE RESPONSIBILITY OF THE CONTRACTOR. CONTRACTOR SHALL VERIFY SHOP DRAWINGS PRIOR AND AFTER REVIEW BY CONSULTANT TO ENSURE PROPOSED EQUIPMENT SUITABLE WITH PROPOSED INSTALLATION BY THE CONTRACTOR.
SUBMIT SHOP DRAWINGS FOR SUCH ITEMS AS :
POWER DISTRIBUTION EQUIPMENT, INCLUDING PANELBOARDS AND BREAKERS, ELECTRIC HEATING WITH COMPLETE INFORMATION ON DIMENSIONS, CAPACITIES, VOLTAGE, OPTIONS, RELAYS & TRANSFORMER DETAILS.

COMMISSIONING

GENERAL ELECTRICAL INSTALLATION:
INSPECT, TEST AND COMMISSION ALL EQUIPMENT AND WORK PROVIDED UNDER THIS CONTRACT TO DEMONSTRATE AND VERIFY CORRECT OPERATION. RECTIFY AND REPLACE, AT NO COST TO THE OWNER, ANY FAULTY OPERATION AND FAULTY EQUIPMENT.
PRIOR TO ENERGIZING, MEGGER ANY NEW FEEDERS AND CHECK INSULATION RESISTANCE TO GROUND BEFORE ENERGIZING.
PERFORM GROUND CONTINUITY AND RESISTANCE TESTS USING METHOD APPROPRIATE TO SITE CONDITIONS.
INSPECT, TEST AND COMMISSION ALL HEATING SYSTEM AND THERMOSTAT/SENSOR CONTROLS INTERFACING WITH EQUIPMENT AND BAS CONTROL SYSTEM IN BUILDING.

OPERATION AND MAINTENANCE MANUAL

SUBMIT ONE MANUAL TO THE CONSULTANT FOR APPROVAL PRIOR TO FORMAL SUBMISSION OF THREE COPIES TO THE OWNER. INCLUDE IN MANUALS, INFORMATION BASED ON THE REQUIREMENT LISTED UNDER SHOP DRAWINGS. OPERATION AND MAINTENANCE DATA TO BE SUFFICIENTLY DETAILED WITH RESPECT TO DESIGN ELEMENTS, OPERATIONAL PROCEDURES, TECHNICAL DATA, CONSTRUCTION FEATURES, COMPONENT FUNCTIONS AND MAINTENANCE REQUIREMENTS TO PERMIT EFFECTIVE START-UP, OPERATION, MAINTENANCE, REPAIR, MODIFICATION, EXTENSION AND EXPANSION OF ANY PORTION OF THE SYSTEM. INCLUDE ALSO ALL UPDATED PANEL SCHEDULES (FOR ANY PANELS MODIFIED), TESTING AND COMMISSIONING RESULTS.

AS BUILT DRAWINGS

SUBMIT TO THE OWNER ONE COMPLETE SET OF PRINTS OF DRAWINGS SHOWING ACCURATE AS-BUILT ELECTRICAL INSTALLATIONS INCLUDING ALL CONDUIT AND WIRING. REVISIONS SHALL BE NOTED IN RED INK. PROVIDE NEATLY TYPED UPDATED PANEL DIRECTORIES FOR ALL PANELS AFFECTED INCLUDING EXISTING PANEL INFORMATION.

PROTECTION

IT IS THE CONTRACTOR'S RESPONSIBILITY TO REVIEW DESIGNATED SUBSTANCES REPORT PREPARED BY TROW ASSOCIATED INC AND DATED 2010 PRIOR TO COMMENCING WITH ANY WORK FOR IMPACT AND PROCEDURES AS A RESULT OF DEMOLITION AND NEW WORK. REFER TO DWG. ME-01 ASBESTOS NOTES FOR ABATEMENT PROCEDURES AND PROTECTION.

TAKE PRECAUTIONS TO PROTECT THE OCCUPANTS AND PERSONNEL FROM INJURY DUE TO LIVE CIRCUITS. PROTECT ALL FINISHED AND UNFINISHED WORK FROM DAMAGE DUE TO CARRYING OUT THIS WORK. ALSO PROVIDE FULL DUST PROTECTION DURING CONSTRUCTION WHERE CONTAMINATION OF DEBRIS IS ANTICIPATED. KEEP EQUIPMENT DRY AND CLEAN AT ALL TIMES. PROTECT ALL EXISTING SERVICES TO REMAIN IN AND AROUND THE AREAS OF RENOVATIONS.

EXISTING SERVICES

GIVE THE OWNER AMPLE NOTICE OF EACH NECESSARY INTERRUPTION OF ELECTRICAL SERVICE DURING THE COURSE OF THE WORK. UNAVOIDABLE INTERRUPTIONS TO EXISTING SYSTEMS/INSTALLATIONS, IF ANY, SHALL BE OF THE SHORTEST POSSIBLE DURATION AND EACH SUCH INTERRUPTION SHALL REQUIRE THE SPECIFIC APPROVAL OF THE OWNER. SUBMIT A SCHEDULE OF ALL ANTICIPATED INTERRUPTIONS, IDENTIFYING EXACTLY WHAT THE INTERRUPTION IS, HOW LONG IT WILL BE, WHEN IT IS PLANNED TO OCCUR AND WHICH AREA(S) WILL BE AFFECTED. GIVE THE OWNER A MINIMUM OF 48 HOURS NOTICE RELATED TO EACH NECESSARY INTERRUPTION. THE OWNER RESERVES THE RIGHT TO DENY APPROVAL FOR AN INTERRUPTION ON ANY SPECIFIC DATE OR TIME. IN THIS CASE, AN ALTERNATIVE TIME SHALL BE MUTUALLY SELECTED. REFER ALSO TO PHASING/ WORK SCHEDULE OF THE PROJECT. THE OWNER IS RESPONSIBLE FOR ANY TEMPORARY SERVICES PROVISIONS REQUIRED TO MAINTAIN POWER TO AREAS DEEMED ESSENTIAL BY OWNER DURING SHUTDOWN PERIODS.

DEMOLITION

REFER TO DEMOLITION NOTES ON DRAWINGS. RENDER SAFE THE INSTALLATIONS AT LOCATIONS FROM WHICH THE EXISTING INSTALLATIONS AND EQUIPMENT HAS BEEN REMOVED AS PART OF THIS WORK. ANY BRANCH CIRCUITS REMAINING THAT ARE INTERRUPTED OR PARTIALLY DISCONNECTED AS A RESULT OF THE WORK ARE TO BE EXTENDED OR REROUTED AS REQUIRED TO ENSURE COMPLETE CIRCUIT/S REMAINING ARE FULLY FUNCTIONAL AFTER DEMOLITION WORK.
REMOVE FROM THE SITE ALL EXISTING EQUIPMENT AND MATERIALS, WHICH BECOMES OBSOLETE AS A RESULT OF THIS WORK EXCEPT WHERE SPECIFICALLY NOTED OTHERWISE.

CUTTING AND PATCHING

PROVIDE ALL CUTTING/CORE DRILLING AND PATCHING REQUIRED FOR THE ELECTRICAL INSTALLATIONS. BEFORE CARRYING OUT ANY CUTTING OR CORING REVIEW EXISTING SITE CONDITIONS FOR POSSIBLE INTERFERENCES OF WORK.

FIREPROOF PATCHING

WHERE CONDUITS OR SINGLE CONDUCTOR CABLES PASS THROUGH FIRE RATED FLOOR SLABS, FIRE RATED CEILING OR FIRE RATED WALLS, SEAL OPENING AROUND WITH SAME TO MAINTAIN FIRE SEPARATION USING ELECTROVERT "FLAMESEAL" PUTTY #AA400 OR APPROVED ULC RATED EQUIVALENT.

CLEAN UP AND REPAIR

CARRY OUT THE REQUIRED CLEANUP AT THE END OF EACH DAY IN WORK AREAS. REMOVE ALL TOOLS, EQUIPMENT, LADDERS AND EMPTY CARDBOARD BOXES ETC. AND LEAVE THE PREMISES CLEAN. THE ELECTRICAL CONTRACTOR SHALL ALSO BE RESPONSIBLE FOR MAKING GOOD ANY DAMAGE TO WALLS, FLOORS, CEILINGS, WOODWORK, FINISHES, ETC. CAUSED DIRECTLY OR INDIRECTLY AS A RESULT OF HIS WORK.

SEISMIC REQUIREMENTS

COMPLY WITH ALL PERTINENT CODE REQUIREMENTS. ELECTRICAL EQUIPMENT AND ASSOCIATED SERVICES REQUIRING SEISMIC RESTRAINTS SHALL INCLUDE, BUT NOT NECESSARILY BE LIMITED TO ALL SUSPENDED EQUIPMENT AND FASTENING OF PANELBOARDS.

ELECTRICAL CONTRACTOR SHALL RETAIN AND PAY FOR THE SERVICES OF A STRUCTURAL ENGINEER LICENSED IN QUEBEC TO PROVIDE STAMPED SHOP DRAWINGS FOR SEISMIC SUPPORT SYSTEM TO SUIT THE ELECTRICAL INSTALLATION. PROVIDE LETTER OF COMPLIANCE FROM STRUCTURAL ENGINEER.

GENERAL MATERIALS

MATERIALS AND EQUIPMENT

EQUIPMENT AND MATERIAL SUPPLIED AS PART OF THE ELECTRICAL WORK SHALL BE NEW AND CSA APPROVED FOR THE APPLICATION.

CONDUIT

WIRING SHALL BE IN CONDUIT UNLESS SPECIFICALLY INDICATED OTHERWISE. PROVIDE EMT THROUGHOUT EXCEPT WHERE SPECIFIED OTHERWISE. CONCEAL CONDUITS/RACEWAYS IN CEILING SPACE OR WALL CAVITIES FOR ALL AREAS EXCEPT IN MECHANICAL AND ELECTRICAL ROOMS OR WHERE SPECIFICALLY INDICATED OTHERWISE OR INSTALLATION CANNOT BE PROVIDED FOR DUE TO SITE CONDITIONS, CONSULT WITH CONSULTANT WHERE CONCEALMENT IS NOT POSSIBLE PRIOR TO INSTALLATION AND ALTERNATIVELY SURFACE MOUNTED RACEWAY IN FINISHED AREAS MAY BE PERMITTED BY CONSULTANT. INSTALL CONDUITS PARALLEL TO BUILDING LINES. INSTALL POLYPROPYLENE, MINIMUM 180 KG PULL STRENGTH PULL CORDS IN EMPTY RACEWAYS AND FASTEN CORDS AT EACH END.

FASTENING AND SUPPORTS

USE LEAD ANCHORS TO SECURE EQUIPMENT TO SOLID MASONRY, TILE AND PLASTER SURFACES. USE EXPANDABLE INSERTS TO SECURE EQUIPMENT TO POURED CONCRETE. USE TOGGLE BOLTS TO SECURE EQUIPMENT TO HOLLOW MASONRY WALLS OR SUSPENDED CEILINGS. SUPPORT GROUPS OF CONDUITS AND CABLES, AND EQUIPMENT ON 1-5/8" X 1-5/8" THICK GALVANIZED CHANNELS EQUAL TO UNISTRUT P-SERIES, USING CLIPS, SPRING LOADED BOLT, CABLE CLAMPS AND THE LIKE, DESIGNED AS ACCESSORIES TO BASIC CHANNEL MEMBERS. FOR SURFACE MOUNTING OF TWO OR MORE CONDUITS USE CHANNELS AT 5"-0" OR LESS ON CENTRE SPACING.

CONDUIT AND CABLE IDENTIFICATION

COLOUR CODE CONDUITS, BOXES AND METALLIC SHEATHED CABLES. FOR BOXES, IDENTIFY THE COVER AS WELL AS INSIDE EACH BOX, IDENTIFICATION SYSTEM TO BE CONFIRMED WITH THE CONSULTANT.

WIRING

- TYPE RW-90 COPPER, 600V TO MAXIMUM #10 AWG AND 1000V #8 AND LARGER, XLPE INSULATION. SOLID CONDUCTORS TO #10 AWG, STRANDED CONDUCTORS #8 AWG AND LARGER. MINIMUM BRANCH CIRCUIT CONDUCTORS SHALL BE #12 AWG EXCEPT FOR 120V CONTROL CIRCUITS. MINIMUM SIZE OF WIRE SHALL BE #14 AWG. WIRING FOR BRANCH CIRCUITS SHALL BE SIZED TO LIMIT THE VOLTAGE DROP FROM THE PANELBOARD TO THE FURTHEST OUTLET TO 2% WHEN CARRYING 80% OF THE BRANCH CIRCUIT BREAKER RATED CURRENT.
- TWIST-ON PRESSURE TYPE WIRE CONNECTORS FOR #10 AWG AND SMALLER AND SPLIT-BOLT TYPE FOR #8 AWG AND LARGER.
- TYPE AC-90 WILL BE PERMITTED FROM CONDUIT SYSTEM JUNCTION BOXES TO HEATING PANELS, CONCEALED AS FINAL DROPS WITHIN FINISHED WALLS TO MINIMIZE DISRUPTION TO EXISTING FINISHES AND FOR FINAL FLEX CONNECTIONS TO MOTOR CONNECTIONS SUCH AS UNIT HEATERS.
- TYPE AC-90 SHALL NOT BE USED FOR ANY OTHER APPLICATION.

GROUNDING / BONDING

BOND TO GROUND ALL EQUIPMENT WITH APPROVED FITTINGS AND BOND CONDUCTORS OF AMPLE CAPACITY AS REQUIRED BY GROUNDING TO CSA C22.1, "ELECTRICAL SAFETY CODE".

INSTALL COMPLETE PERMANENT, CONTINUOUS, SYSTEM AND CIRCUIT, EQUIPMENT, GROUNDING/BONDING SYSTEMS INCLUDING CONDUCTORS, CONNECTORS, ACCESSORIES, AS INDICATED, TO CONFORM TO REQUIREMENTS OF CONSULTANT, AND LOCAL AUTHORITY HAVING JURISDICTION OVER INSTALLATION. PROVIDE INSULATED GROUND WIRES FOR ALL BRANCH CIRCUITS AND MOTOR CIRCUITS BY RUNNING THE BONDING WIRES IN THE SAME CONDUIT AS FOLLOWS:
MINIMUM SIZE OF BONDING WIRE TO BE #12 AWG COPPER OR AS REQUIRED TO SATISFY CODE. INSTALL CONTINUOUS BONDING CONDUCTORS THROUGH ALL CONDUITS/RACEWAYS FOR SYSTEMS OPERATING ABOVE 50 VOLTS, BOND AT EACH BOX AND DEVICE. BOND TO GROUND ALL METALLIC RACEWAYS FOR HEATING SYSTEM.

MOUNTING HEIGHTS

MOUNTING HEIGHT OF EQUIPMENT IS FROM FINISHED FLOOR TO CENTRELINE OF EQUIPMENT UNLESS OTHERWISE SPECIFIED OR INDICATED. INSTALL ELECTRICAL EQUIPMENT AT THE FOLLOWING HEIGHTS UNLESS INDICATED OTHERWISE:
BASEBOARD HEATERS: 1/2" FROM FLOOR TO BOTTOM OF HEATER OR TO SUIT EXISTING CONDITIONS.
THERMOSTATS: 48" AFF
PANELBOARDS: 72" TO TOP

DISTRIBUTION PANELBOARDS & PANELBOARDS

600V PANELBOARD: MAINS BUS, NUMBER OF CIRCUITS, NUMBER AND SIZE OF BOLT-ON BRANCH CIRCUIT BREAKERS AND SYMMETRICAL INTERRUPTING CAPACITY OF 18KA. PANELBOARDS COMPLETE WITH GROUND BUS AND SOLID NEUTRAL. TRIM WITH CONCEALED FRONT BOLTS AND HINGES. TRIM AND DOOR MINIMUM 12 GAUGE, AND FINISHED BAKED GREY ENAMEL. TWO KEYS FOR EACH PANELBOARD.

MOULDED CASE BREAKERS

BOLT-ON MOULDED CASE CIRCUIT BREAKER: QUICK-MAKE, QUICK-BREAK TYPE, FOR MANUAL AND AUTOMATIC OPERATION WITH TEMPERATURE COMPENSATION FOR 40°C AMBIENT. COMMON-TRIP BREAKERS. WITH SINGLE HANDLE FOR MULTI-POLE APPLICATIONS. MOULDED CASE CIRCUIT BREAKER TO OPERATE AUTOMATICALLY BY MEANS OF THERMAL AND MAGNETIC TRIPPING DEVICES TO PROVIDE INVERSE TIME CURRENT TRIPPING AND INSTANTANEOUS TRIPPING FOR SHORT CIRCUIT PROTECTION.

INTERRUPTING CAPACITY OF NEW BREAKERS MUST BE GREATER THAN OR EQUAL TO THE INTERRUPTING RATING OF BREAKERS WITHIN PANEL. IF INTERRUPTING RATINGS DIFFER BETWEEN BREAKERS THE HIGHEST INTERRUPTING RATING MUST BE SELECTED. IF A SERIES RATING IS INDICATED ON PANEL, CONTRACTOR IS RESPONSIBLE FOR PURCHASING BREAKERS, WHICH MAINTAIN THE SERIES RATING. BREAKERS SUPPLIED BY CONTRACTOR MUST MATCH THE MANUFACTURER OF PANEL.

DISCONNECT SWITCHES

HEAVY DUTY DISCONNECT SWITCHES, EEMAC 1 IN DRY LOCATIONS, EEMAC 3 IN DAMP LOCATIONS, QUICK-MAKE/QUICK-BREAK MECHANISMS, VISIBLE BLADES, ARC QUENCHER FOR SWITCHES RATED 600V. MECHANICALLY INTERLOCKED COVER TO PREVENT OPENING IN 'ON' POSITION, EXCEPT BY DEFEAT MECHANISM. ON-OFF SWITCH POSITION INDICATION ON SWITCH ENCLOSURE COVER. PROVISION FOR PADLOCKING IN BOTH 'ON' AND 'OFF' POSITIONS. HRC FUSE HOLDERS SIZE AS INDICATED.

FUSES

HRC FUSES MINIMUM 100,000A I.C. HRCI-J, FOR RATINGS 0-600A. WHERE TIME DELAY CHARACTERISTIC (J1 OR L1) IS INDICATED, FUSES SHALL CARRY 500% OF RATING FOR 10 SECONDS AND BE LABELED "TIME DELAY".

EQUIPMENT IDENTIFICATION

IDENTIFY DISTRIBUTION EQUIPMENT USING SUITABLY SIZED LAMACOID NAMEPLATES.

ELECTRIC HEATERS:

GENERAL:

BASEBOARD HEATERS TO BE CONTROLLED BY EXISTING OR NEW REMOTE LOW VOLTAGE THERMOSTAT AND TRIAC CONTROLLERS SUPPLIED BY CONTROLS CONTRACTOR. LOW VOLTAGE WIRING & INTERFACING WITH EXISTING BUILDING CONTROL SYSTEM BY CONTROLS CONTRACTOR.
BALANCE HEATER LOADING AT PANELS ACROSS THREE PHASES TO ENSURE SINGLE PHASE LOADS ARE EVENLY PLACED ACROSS ALL PHASES AS POSSIBLE, ADJUST POSITION OF BREAKERS TO SUIT.

COMMERCIAL BASEBOARD HEATER:

SURFACE MOUNTED, RIGID ALUMINIUM COVER WITH 20 GAUGE STEEL CABINET, STAINLESS STEEL TUBULAR ELEMENT WITH ALUMINIUM FINS, FACTORY STANDARD FINISHED IN WHITE POWDER COAT, BUILT-IN WIRING COMPARTMENT, 600V, 1Ø, STANDARD WATT DENSITY OF 275W/FT. WITH WATTAGE AS INDICATED ON PLANS. STANDARD OF ACCEPTANCE: STANDARD OF ACCEPTANCE: OUELLET SERIES OOL. STANDARD RESIDENTIAL BASEBOARD HEATERS WILL NOT BE CONSIDERED ACCEPTABLE FOR THIS APPLICATION.

COMMERCIAL UNIT HEATER:

SUSPENDED FROM CEILING OR WALL MOUNTED C/W MOUNTING HARDWARE/BRACKETS, 18 OR 20 GAUGE STEEL CONSTRUCTION, ADJUSTABLE LOUVRES, HIGH LIMIT TEMPERATURE CONTROL WITH AUTO RESET, THERMALLY PROTECTED FAN MOTOR, STAINLESS STEEL TUBULAR ELEMENT OR FINNED TO SUIT KW RATING REQUIREMENTS, FACTORY STANDARD FINISHED IN ALMOND POWDER COAT, FACTORY INSTALLED LOW VOLTAGE TRANSFORMER & CONTACTOR SUITABLE TO VOLTAGE/PHASE FOR REMOTE L/V T'STAT. CONTROL : RATED 600V, 1Ø OR 3Ø AS APPLICABLE, WITH WATTAGE AS INDICATED ON PLANS. STANDARD OF ACCEPTANCE: OUELLET SERIES OAS.

FORCED FLOW ENTRANCE HEATER:

ARCHITECTURAL STYLE FOR SURFACE OR RECESSED WALL MOUNTED, EXTRUDED ALUMINIUM FRONT GRILLE AND 20 GAUGE STEEL CABINET, BOTTOM AIR OUTLET, HIGH LIMIT TEMPERATURE CONTROL WITH AUTO RESET, THERMALLY PROTECTED FAN MOTOR, TUBULAR HEATING ELEMENT WITH FINS, FACTORY STANDARD FINISHED IN WHITE POWDER COAT, FACTORY INSTALLED BUILT-IN T'STAT WHERE INDICATED ON PLANS AND BUILT IN TRANSFORMER/RELAY FOR REMOTE T'STAT CONTROL AS APPLICABLE. HEATER RATED 600V, 1Ø, WITH WATTAGE AS INDICATED ON PLANS. INSTALL MIN. 10" FROM FINISHED FLOOR AND ADJACENT WALL SURFACES OR TO MANUFACTURER'S RECOMMENDATIONS. PROVIDE ALL REQUIRED OPTIONS FOR A COMPLETE SYSTEM OPERATION. STANDARD OF ACCEPTANCE: OUELLET SERIES OAWH.



Capital Planning and Real Asset Management Branch
Direction de l'aménagement de la capitale et gestion de l'immobilier

Design and Construction Division
Division design et construction

director - Daniel Miron - directeur

consultant
expert-conseil



issued or revised émis ou révisé		
2	ISSUED FOR TENDER	2013-06-07
1	ISSUED FOR 100%	2013-03-28
no.	description	date

project
projet

**HEATING SYSTEM
UPGRADES - GATINEAU PARK
VISITORS' CENTER
CENTRE DES VISITEURS DU
PARC DE LA GATINEAU
MODIFICATIONS AU SYSTÈME
DE CHAUFFAGE**

drawing
dessin

**ELECTRICAL
DRAWING LIST, LEGEND &
SPECIFICATIONS**

approved by approuvé par	J.H.		
designed by conçu par	D.R.		
drawn by dessiné par	D.R.		
date	MARCH 2013	scale échelle	NONE
NCC project no. no. du projet de la CCN		sheet no. no. de la feuille	
DC3020-5			ME-03

GENERAL NOTES:

1. ALL ELECTRICAL EQUIPMENT SHOWN WITH LIGHT BACKGROUND & DASHED IS EXISTING TO REMAIN AND FOR INFORMATION PURPOSES ONLY.
2. ALL ELECTRICAL EQUIPMENT SHOWN WITH LIGHT BACKGROUND & HATCHED INDICATES EXISTING TO BE REMOVED.
3. ALL ELECTRICAL EQUIPMENT NOTED SHOWN BOLD WITH SOLID LINES IS NEW.
4. DISCONNECT AND REMOVE ALL ELECTRICAL CIRCUITS ASSOCIATED WITH DEMOLITION OF EXISTING HOT WATER SYSTEM SUCH AS BOILER, ASSOCIATED CIRC. PUMPS, UNIT HEATER FANS/CONTROLS, ETC. UPDATE EFFECTED PANEL DIRECTORIES AS REQUIRED.

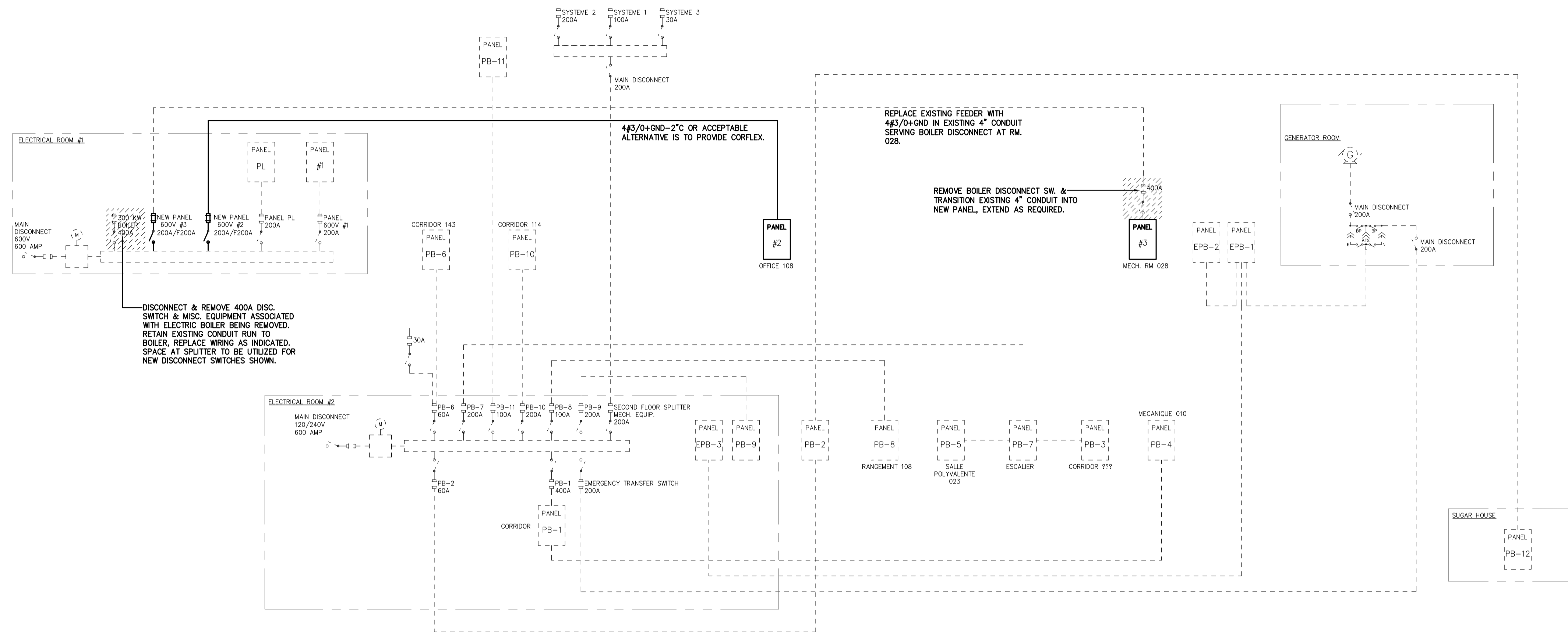

issued or revised / émis ou révisé		
no.	description	date
2	ISSUED FOR TENDER	2013-06-07
1	ISSUED FOR 100%	2013-03-28

project / projet: HEATING SYSTEM UPGRADES - GATINEAU PARK VISITORS' CENTER
CENTRE DES VISITEURS DU PARC DE LA GATINEAU
MODIFICATIONS AU SYSTÈME DE CHAUFFAGE

drawing / dessin

ELECTRICAL
REVISED SINGLE LINE DIAGRAM.

approved by / approuvé par: J.H.
designed by / conçu par: D.R.
drawn by / dessiné par: D.R.
date: MARCH 2013 scale / échelle: NONE
NCC project no. / sheet no. / no. du projet de la CCN / no. de la feuille: DC3020-5 ME-05

\\SERV-NEP-DATA\PROJECTS\131-13000\S\131-13714-00_33_SCOTT_HEATING_SYSTEM_UPGRADES\STRUCTURAL\WORKING DRAWINGS\131-13714-SK1.DWG

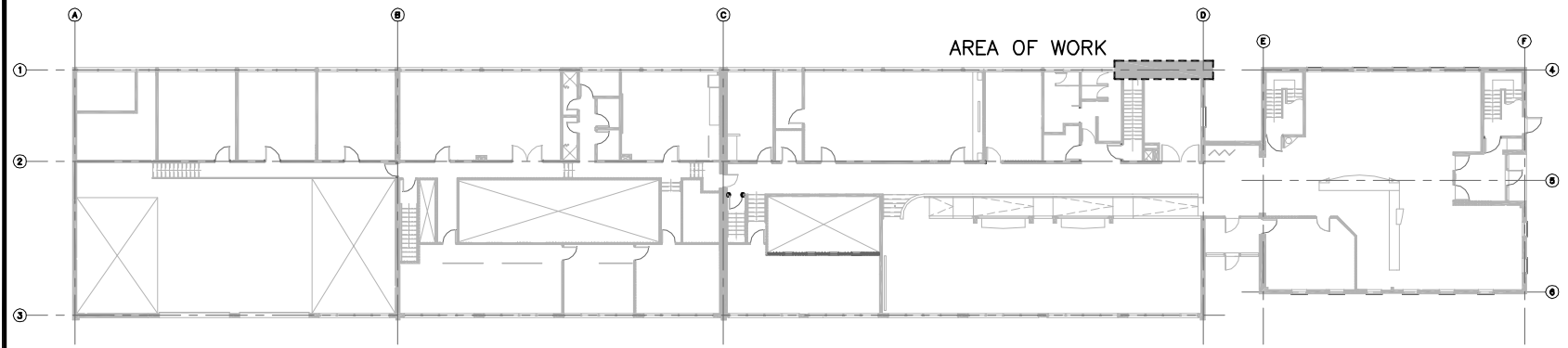

1 **GROUND FLOOR KEY PLAN**
SK1 N.T.S

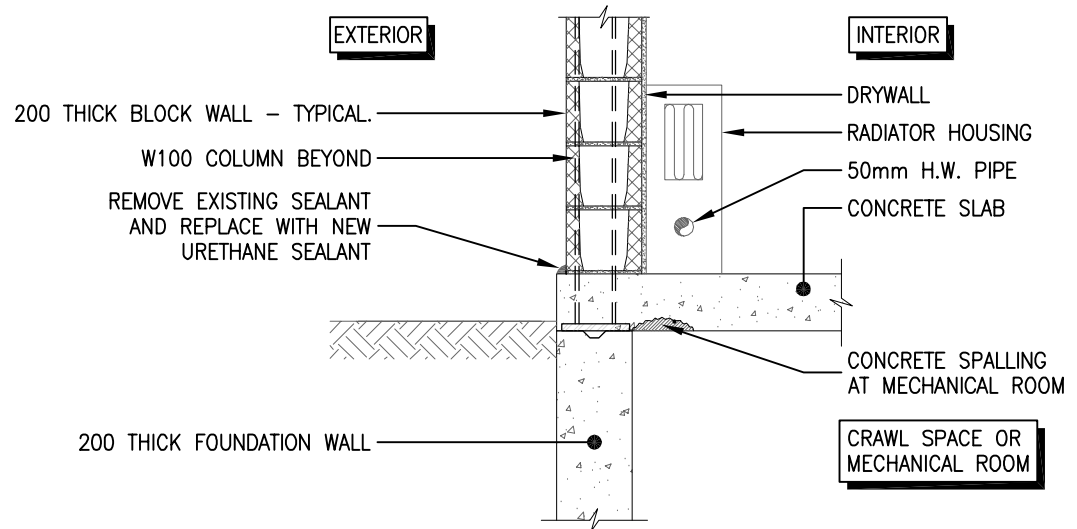

2 **TYP. WALL SECTION**
SK1 SCALE 1 : 20

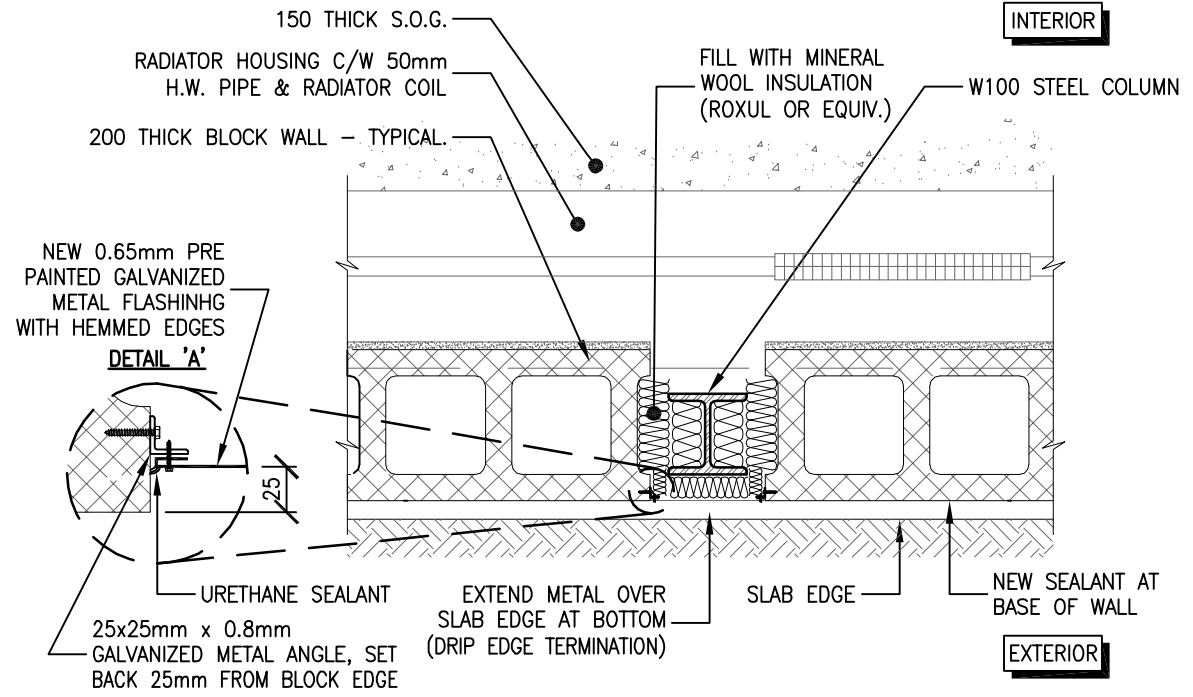

3 **TYP. STEEL COLUMN @ EXTERIOR WALL**
SK1 N.T.S

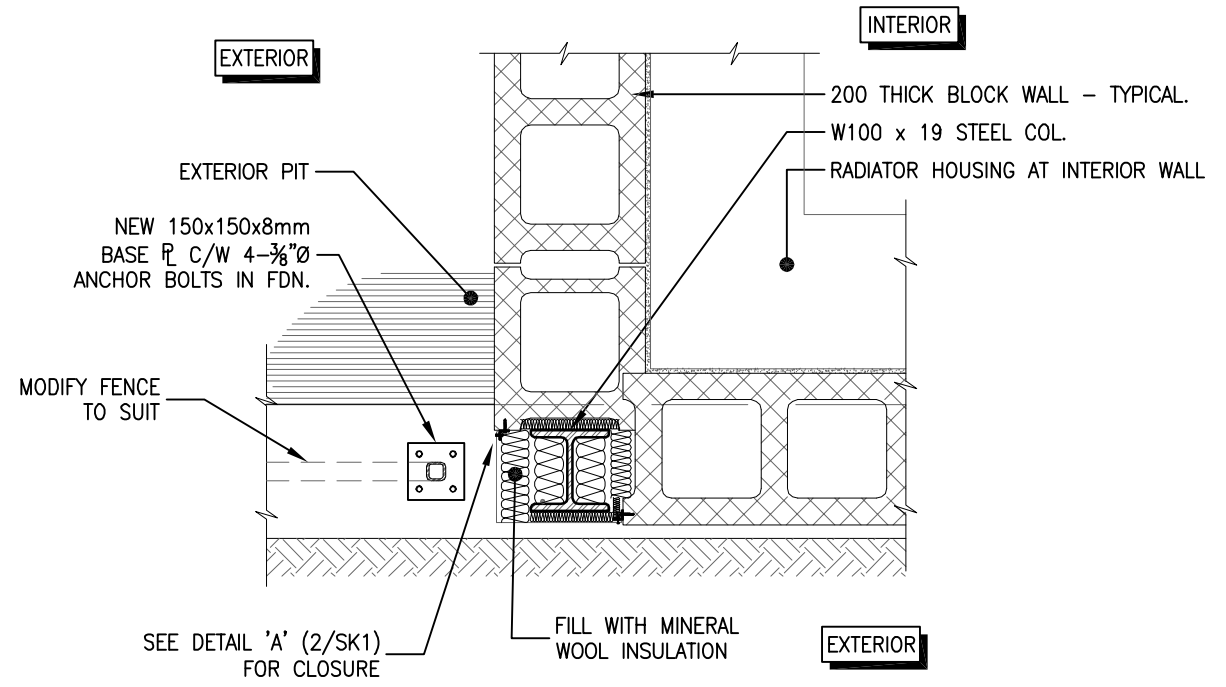

4 **STEEL COLUMN @ SOUTH-EAST CORNER**
SK1 N.T.S

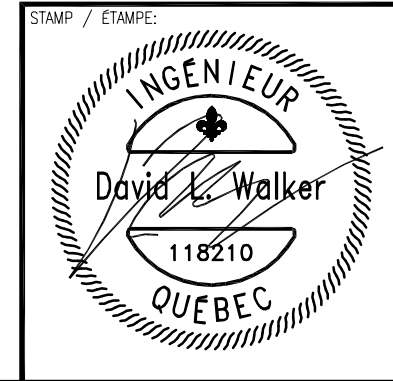

PROJECT / PROJET: NCC VISITOR CENTER 33 SCOTT ROAD, CHELSEA, QC.	PROJECT NO / NO PROJET: 131-13714-00 SCALE / ÉCHELLE: AS SHOWN	SUPPLEMENTAL: ADDENDUM / ADDENDUM: ADD_# <input type="checkbox"/> DIRECTIVE / DIRECTIVE: DIR_# <input type="checkbox"/> CHANGE ORDER / ORDRE DE CHANGEMENT: CHG_# <input type="checkbox"/>
TITLE / TITRE: DETAILS	DRAWN BY / DESSINÉ PAR: N. K. - M. P. CHECKED BY / VÉRIFIÉ PAR: D. WALKER	REVISION / RÉVISION: ISSUED FOR TENDER DATE / DATE: 2013/05/22 SUPPLEMENTAL NO / DESSIN NO: SK1