

READ IN CONJUNCTION WITH DRAWING:

DIALOG[®]

PROJECT TITLE: Granville Island Public Market Patio
 PROJECT #: 0903
 DRAWING TITLE: Location + Context Plans

DRAWING #: A000
 DRAWN BY: SL
 CHECKED BY:
 DATE: 2013 04 19

Part 1 General

1.1 Section Includes

- .1 General Instructions applicable to all portions of the Work.

1.2 Summary of work:

- .1 Removal of existing decking and substructure
- .2 Clearing of riprap
- .3 Construction of a concrete and timber structure
- .4 Construction of an illuminated steel canopy frame and cover
- .5 Re-grading of pavers

1.3 Notification of Authorities

- .1 Notify the appropriate authorities of intention to carry out operations in the vicinity of a utility or structure at least one week prior to the commencement of such operation and obtain approval for access to any operations carried out on adjacent public and private property, if and as required.

1.4 Documents Required

- .1 The following documents shall be retained on site at all times:
 - .1 Contract Drawings.
 - .2 Specifications.
 - .3 Addenda.
 - .4 Reviewed Shop Drawings.
 - .5 Change Orders.
 - .6 Other modifications to the Contract.
 - .7 Field Test Reports.
 - .8 Vancouver Building By-Laws, B.C. Plumbing Code, B.C. and Canadian Electrical Codes, together with all supplements, Occupational Environment Regulations.

1.5 Construction Progress Schedule

- .1 Provide, within seven (7) working days after Contract award, schedule showing anticipated progress stages and final completion of work within time period required by the Contract Documents.
- .2 Throughout the duration of the Work, revise schedule whenever any significant change occurs that, in the opinion of the Consultant, necessitates revisions.

1.6 Cost Breakdown

- .1 Before submitting first progress claim, submit breakdown of the Contract Price in detail as directed by the Consultant. After approval by the Consultant, the cost breakdown will be used as basis for progress payment.

1.7 Project Meetings

- .1 Record and distribute minutes of Project Meetings.
- .2 Arrange project meetings and assume responsibility for setting times.

1.8 Fees, Permits, Licenses

- .1 The Building Permit may be obtained and paid for by the Owner. Obtain and pay for all other permits, licenses including business license and certificates required for performance of the work. Provide the inspection authorities with such plans and information as may be required for issue of acceptance certificates. Furnish inspection certificates in evidence that works installed conform with the requirements of the authority having jurisdiction.

1.9 Codes and Standards

- .1 Execute the work in accordance with the Vancouver Building By-Law.
- .2 Conform to the latest issue of codes and standards specified, as amended and revised on the date of receipt of Tenders unless otherwise required to meet applicable Codes and Standards.
- .3 Materials and workmanship must conform to or exceed applicable standards of Canadian Government Specification Board (CGSB), Canadian Standards Association (CSA), American Society for Testing and Materials (ASTM) and other referenced organizations.
- .4 If required by the Consultant, furnish documentation indicating compliance with the specified requirements including certification by a Professional Engineer registered in the Province of British Columbia.

1.10 Alternative and Equivalent Products

- .1 Only products and methods specified shall be used, or such products and methods approved as equivalent. Alternative products and methods may be used only where approved in writing by the Consultant prior to the submission of the Bid Price. If requested by the Consultant, alternatives may be considered after submission of the Bid Price.
- .2 Application for approval of equivalent or alternative products will be received by the Consultant up to three (3) days prior to close of Bids, other than as noted above.
- .3 Submit request for approval, in duplicate, to the Consultant. List specification section or drawing number and page, brand, model, and manufacturer of specified product and proposed product, with full supporting technical specifications, data, and samples.
- .4 Approval of products does not relieve the Contractor from meeting the requirements of the specifications, and for all maintenance that may be required for incorporation of them into the work.
- .5 Make all changes necessitated by use of the alternative at no extra cost to the Owner.

1.11 Safety Requirements

- .1 Observe and enforce all construction safety measures by the Canadian Construction Safety Code supplemented by the Vancouver Building By-Law, applicable Workers' Compensation Board (WorkSafe BC) requirements, and local statutes and By-laws.

- .2 In the event of conflict between any provisions of the above authorities, the most stringent will apply.
- .3 If required to be in compliance with the Vancouver Building By-Law the employ a Construction Safety Officer.
- .4 Where applicable obtain copies of the Project Safety Program, be familiar with and comply with same and a Project Safety and Loss Control Program. Comply with all laws, regulations, and codes concerning safety as applicable to the work and to the safety standards established during the progress of the work by the Consultant or Authorities Having Jurisdiction and conduct all operations within the Project Safety Policy. Make copies of the Project Safety and Loss Control Program available at the Project Site Office.

1.12 Workers' Compensation (WorkSafe BC)

- .1 Prior to commencing work and prior to receiving payment for Substantial Performance of the work, provide evidence of compliance with all requirements of the Workers' Compensation Board (WorkSafe BC), including payments due thereunder.
- .2 At any time during the term of the Contract, when requested by the Consultant, provide such evidence of compliance for any or all subcontractors.

1.13 Protection of Public Work And Property

- .1 Adequately protect all work completed or in progress. Remove and replace or repair as directed by the Consultant at no increase in the Contract Price any work damaged or defaced due to failure to provide such protection.
- .2 Prevent overloading of any part of the building. Do not cut, drill or otherwise sleeve any load-bearing structural member without written approval of the Consultant.
- .3 Assume responsibility for any damage to existing paving, walks, adjacent building and property, services, etc., caused by construction operations.
- .4 The Contractor's attention is directed to the existence and possible existence of aerial and underground power lines, pipelines and otherwise concealed and other public or private improvements which may be within the work area or adjacent thereto and may or may not be shown in the Contract Documents. The fact that any aerial or underground facility is not shown upon the plans does not relieve the Contractor of his responsibility to ascertain the existence, position and ownership of any such structures that may be subject to damage by reason of his operations. Take every precaution to preserve and protect any such improvement from injury or damage during the Work.
- .5 Notify the Consultant immediately of any damage to existing amenities or services and remove and replace completed work as necessary to allow repairs or replacement to affected damaged amenities or services. Maintain access to existing manholes, catch basins, electrical pull boxes, fire hydrants, valve boxes and allied services underground and on the surface.

1.14 Cooperation and Coordination

- .1 Coordinate the work of sub-contractors with efficient and continuous supervision.
- .2 Cooperate with the authorities having jurisdiction and other Contractors engaged in simultaneous development of adjacent facilities. Coordinate access to the site, the location, removal or adjustment of temporary fences, sheds and utility services.

- .3 Coordinate the work of all trades requiring suspension or fixing devices to be incorporated into the structure. Where required, such suspension or fixing devices are to be built into the structure and/or by of the type specified or detailed submit to the Consultant details of the device proposed accompanied information that Consultant may require to assess the capability of the proposed device.
- .4 Other Contractors may be independently appointed by the Owner. Cooperate with these other Contractors and allow them to proceed with their work.

1.15 Weather Conditions

- .1 Continue work through normal weather conditions, without interruptions or shutdowns.

1.16 Specifications

- .1 The Specifications are complementary to the Drawings and Details and what is required by any one shall be as binding as if required by all.
- .2 The General Conditions of the Contract, Supplementary Conditions, and General Requirements all form an integral part of each individual section of the Specifications. Read, interpret, and coordinate with all other parts.

1.17 Trademarks and Labels

- .1 Trademarks and labels, including applied labels and construction markings must not be visible in the finished work. Remove such trademarks or labels by grinding if necessary, or paint out where the particular material is being painted. The exception of this requirement is those labels essential to obtain identification of mechanical and electrical equipment and where required by Code to ensure compliance.

1.18 Shop Drawings, Submittals

- .1 Submit to the Consultant for review, shop drawings, product data, and samples specified and noted on the drawings.
- .2 Throughout the duration of the Contract, whenever requested to do so by the Consultant submit product samples and colour charts. This of particular importance where materials are described in generic terms on the drawings.
- .3 Do not proceed with work involving relevant product until submission is reviewed.
- .4 Prepare Shop Drawings, which illustrate appropriate portion of work; showing fabrication, layout, setting or erection details and as specified in relevant Sections.
- .5 Review shop drawings, product data, and samples prior to submission.
- .6 Verify and clearly identify on each shop drawing:
 - .1 Field measurements.
 - .2 Field construction criteria.
 - .3 Catalogue numbers and similar data.
- .7 Coordinate each submission with requirements of the Work and Contract Documents.
- .8 Include the Contractor's stamp, initialed or signed, certifying review of submission, verification of field measurements and compliance with the Contract Documents.

- .9 The Contractor's responsibility for errors and omissions is not relieved by the Consultant's review of submittals.
- .10 The Contractor's responsibility for deviations in submission from requirements of the Contract Documents is not relieved by the Consultant's review of submission, unless the Consultant gives written acceptance of specified deviations.
- .11 Notify the Consultant, in writing, at time of submission, of deviations from requirements of the Contract Documents.
- .12 Letters of Assurance: Where requested or required by the Authority having jurisdiction Submit Letters of Assurance in accordance with the requirements and format of the Authority having jurisdiction.
- .13 Schedule submissions at least ten (10) working days before dates that reviewed submissions will be needed.
- .14 Product Data:
 - .1 Preparation:
 - .1 Clearly mark each copy to identify pertinent products or models.
 - .2 Show performance characteristics and capacities.
 - .3 Show dimensions and clearances required.
 - .4 Show wiring or piping diagrams and controls.
 - .2 Manufacturer's Standard Schematic Drawings and Diagrams:
 - .1 Modify drawings and diagrams to delete information which is not applicable to the work.
 - .2 Supplement additional information to provide information specifically applicable to the work.
- .15 Samples:
 - .1 Provide office samples of sufficient size and quantity to clearly illustrate:
 - .1 Functional characteristics of the product, with integrally related parts and attachment devices.
 - .2 Full range of colour, texture, and pattern.
 - .2 Field Samples:
 - .1 Provide Field Samples as requested in relevant Sections.
 - .3 Number of submittals required:
 - .1 Product data: Submit the number of copies which the Contractor requires, plus three copies which will be retained by the Consultant and Owner Representative.
 - .2 Samples: Submit the number stated in each Specification Section.
 - .3 Shop Drawings: Submit one reproducible plus four prints which will be retained by the Consultant/Owner Representative or as specified in Structural, Mechanical, and Electrical divisions. The Consultant may permit electronic copies of shop drawings submitted by email.
 - .4 Submittals shall contain:
 - .1 The date of submission and the dates of any previous submissions.
 - .2 The project title and number.
 - .3 Contract identification.
 - .4 The names of the Contractor, the Supplier and the Manufacturer.

- .5 Identification of the product, with the specification number.
- .6 Field dimensions, clearly identified as such, in imperial.
- .7 Relation and connection to adjacent or critical features of the work or materials.
- .8 Applicable standards, such as CSA, CGSB, or ASTM numbers.
- .9 Identification of deviations from Contract Documents.
- .10 Identification of revisions on resubmittals.
- .11 The Contractor's stamp, initialed or signed, certifying to review of submittal, verification of products, field measurements and field construction criteria, and coordination of the information within the submittal with requirements of the work and of the Contract Documents.
- .12 Provide Engineer's seal where required.

1.19 Mock-Ups

- .1 Locate where directed by Consultant.
- .2 Approved mock-ups may remain as part of the Work.
- .3 Mock-up will be used for testing to determine compliance with performance requirements. Perform the tests as requested by the Consultant.
- .4 Mock-ups will be used to judge workmanship, substrate preparation, operation of equipment and material application.
- .5 Construct full size mock ups on site of the following conditions in locations directed by the Design Consultant. Make changes to the mock ups as directed by the Design Consultant. Mock ups once accepted, may be used in the finished work and will serve as a standard against which other work will be judged.
 - .1 Deck edge, bull rail, and concrete wall interface.
 - .2 All mock up inspections are to be indicated on the construction schedule.

1.20 Resubmission Requirements

- .1 Make any corrections or changes in the submittals required by the Consultant/Owner Representative and resubmit until stamped as reviewed.
- .2 Shop drawings and product data:
 - .1 Review initial drawings or data, and resubmit as specified for the initial submittal.
 - .2 Indicate any changes which have been made other than those requested by the Consultant/Owner Representative.
- .3 Samples: Submit new samples as required for initial submittal as soon as possible after notification of the rejection or disapproval of the original submission and shall be marked "re-submitted sample."

1.21 Workmanship

- .1 General:
 - .1 Workmanship shall be the best quality, executed by workers experienced and skilled in the respective duties for which they are employed. Immediately notify the Construction Manager or Consultant if required work is such as to make it impractical to produce required results.

- .2 Do not employ any unfit person or anyone unskilled in their required duties. The Construction Manager reserves the right to require the dismissal from the site, workers deemed incompetent, careless, insubordinate or otherwise objectionable.
- .3 Decisions as to the quality or fitness of workmanship in cases of dispute rest solely with the Consultant, whose decision is final.
- .2 Coordination:
 - .1 Ensure co-operation of workers in laying out the work. Maintain efficient and continuous supervision.
 - .2 Be responsible for coordination and placement of openings, sleeves, and accessories.

1.22 Location of Equipment and Fixtures

- .1 Location of equipment, fixtures, and outlets indicated or specified are to be considered as approximate. Location of service runs, ducts, conduits, piping, suspension systems, and other concealed items shown on drawings are diagrammatic.
- .2 Locate equipment, fixtures, and distribution systems to provide minimum interference and maximum usable space and in accordance with manufacturer's recommendations for safety, access, and maintenance.

1.23 Concealment

- .1 Conceal pipes, ducts, and wiring in floor, wall, and ceiling construction of finished areas except where indicated otherwise.

1.24 Requests for Inspection

- .1 Requests for Interim and Final Inspections must be in writing. The requests for Interim will read "fully completed". The Final will read "all deficiencies fully completed". Requests for these inspections must be in writing seven (7) days prior to inspection.

1.25 Inspection and Testing Extra Costs

- .1 When Interim or Final Inspections and tests of installation, assemblies, and equipment fail to receive approval of the Consultant, Municipal, Public Utility and/or manufacturer's inspectors, all costs incurred by any of these authorities to revisit the project site for further inspection and tests will be paid by the Contractor.
- .2 Requests for re-inspections to be in writing to the Consultant or applicable authority.

1.26 Disposal of Wastes

- .1 Recycle cardboard, wood, metals and plastic.
- .2 Fires, burning or burying of rubbish and waste materials on the site are not permitted.
- .3 Disposal of waste or volatile materials, such as mineral spirits, oil or paint thinner into waterways, storm or sanitary sewers are prohibited.
- .4 Provide a container for waste. Drywall and other hazardous material shall be kept separate. Dispose of all waste materials in a legal manner.

1.27 Project Record Documents

- .1 As-Built Drawings:
 - .1 Keep one set of white prints of all contract drawings, including all addenda, revisions, clarifications, change orders and approved shop drawings in the site office and identify them as "As-Built drawings".
 - .2 As the work proceeds, record clearly and indelibly in red pencil "as-built" conditions wherever they deviate from the original directions of the contract drawings.
 - .3 At Substantial Performance, submit the As-Built Drawings to the Consultant.
 - .4 Certify to the Consultant that the white prints provided represent the work "as-built".
 - .5 Record the deviations including, in general, items that are hidden from view and items of major importance to future operations and maintenance and to future alternations and additions.
 - .6 If allowed by the governing Lien Act, a holdback from the monies due to the Contractor will be maintained until all the "as-built" white prints are certified as correct and delivered to the Consultant.
- .2 Recording:
 - .1 Label each document "PROJECT RECORD" in neat large printed letters.
 - .2 Record information concurrently with construction progress. (Do not conceal any work until required information is recorded.)
 - .3 Drawings: Legible mark to record actual construction:
 - .1 Location of internal utilities and appurtenances, concealed in the construction, referenced to visible and accessible features of the structure.
 - .2 Field changes of dimension and detail.
 - .3 Changes made by Field Order or by Change Order.
 - .4 Details not on original contract drawings.
 - .3 Submittal: At the time of application for substantial performance, deliver Record Documents to the Consultant.

1.28 Cleaning During Construction

- .1 Use only cleaning materials recommended by manufacturer of surface to be cleaned, and as recommended by cleaning material manufacturer.
- .2 Maintain project grounds and public properties free from accumulations of waste materials and rubbish.

1.29 Guarantees and Warranties

- .1 Upon Substantial Performance of the Project, furnish to the Owner a guarantee in writing stating that the Contractor shall make good, at his expense and to the satisfaction of the Consultant, all defects which may develop in materials and equipment used on the work, for a minimum period of one (1) year, except where required in excess of one year, upon Substantial Performance, which are, in the opinion of the Consultant, due to the use of improper workmanship and/or faulty materials and equipment.
- .2 In the case of the work performed by his Subcontractor and where guarantees are required, secure such guarantees from the subcontractors and furnish them to the Owner on or before the substantial performance of the project.

- .3 Provide guarantees that all the work furnished and installed by the guarantors shall remain in perfect condition and working order for the period of one or more years (as the case may be) from Substantial Performance of the project, and that the guarantors will replace same with new and like materials at no expense to the Owner unless it can be proven that the defects are caused by abuse and negligence on the part of the Owner or his employees.
- .4 Bear all costs involved in removing or replacing adjacent materials affected by the replacement of defective work which may be disturbed and which is required to complete restoration of the original finish.

1.30 Maintenance Manual

- .1 On completion of the Contract, submit to the Consultant three (3) copies of Operations Data and Maintenance Manual in English, made up as follows:
 - .1 Bind data in vinyl, hard-covered, 3-ring, loose leaf binder for 8 ½" x 11" size paper.
 - .2 Enclose title sheet, labelled "Operations Data and Maintenance Manual", project name, date, and list of contents.
 - .3 Organize contents into applicable sections of work to parallel project specification breakdown. Mark each section by labelled tabs protected by celluloid covers fastened to hard paper dividing sheets.
- .2 Include the following information plus data specified in various sections:
 - .1 Maintenance instructions for finished surfaces and materials.
 - .2 Copy of hardware and paint schedule.
 - .3 Description, operation, and maintenance instructions for equipment and systems, including a complete list of equipment and parts list. Indicate nameplate information such as size, capacity, and serial number.
 - .4 Names, addresses, and phone numbers of subcontractors and suppliers.
 - .5 Guarantees, warranties, and bonds showing:
 - .1 Name and address of project.
 - .2 Guarantee commencement date (date of Final Certificate of Completion).
 - .3 Duration of guarantee.
 - .4 Clear indication of what is being guaranteed and what remedial action will be taken under guarantee.
 - .5 Signature and seal of Contractor.
- .3 Neatly type lists and notes. Use clear drawings, diagrams or manufacturer's literature.
- .4 Include one complete set of final shop drawings (bound separately), indicating corrections and changes made during fabrication and installation.

1.31 Making Good

- .1 Make good all surfaces and installations disturbed in any way by the Work of the Contract.
- .2 Refinish surfaces to match adjacent finishes; for continuous, surfaces refinish to nearest intersection; for assembly, refinish entire unit.

1.32 Adjacent Property

- .1 The Contractor shall conduct construction operations with minimum interference to adjacent roadways, sidewalks, and access facilities in general. Keep such areas free from materials, debris, and equipment at all times. Confine operations to areas designated by the Consultant and/or Owner. Maintain fire vehicular access to existing building at all times.

1.33 Construction Facilities and Temporary Controls

- .1 Installation/Removal
 - .1 Provide construction facilities and temporary controls in order to execute work expeditiously.
 - .2 Remove from site all such facilities after use.
- .2 Scaffolding
 - .1 Provide and maintain scaffolding, ramps, ladders, and platforms as needed.
 - .2 Design and construct scaffolding in accordance with CSA S269.2-M87(R1998).
- .3 Hoisting
 - .1 Provide, operate and maintain hoists and cranes required for moving of workers, materials and equipment and materials. Make financial arrangements with Subcontractors for use thereof.
 - .2 Hoists and cranes shall be operated by qualified operator.
- .4 Guard Rails and Barricades
 - .1 Provide as required by governing authorities, secure, rigid guard railings and barricades around deep excavations, open shafts, open stair wells, open edges of floors and roofs.
 - .2 Provide fall protection as required by WorkSafe BC (WCB) and authorities having jurisdiction.
- .5 Sanitary Facilities
 - .1 Maintain in clean condition.
 - .2 Existing facilities as designated may be used during construction period.
- .6 Access to Site
 - .1 Provide and maintain access roads, sidewalk crossings, ramps and construction runways as may be required for access to the Work.
- .7 Construction Parking
 - .1 Parking as directed by Owner will be permitted on site provided it does not disrupt the performance of Work.
 - .2 Coordinate with Owner and Construction Manager as required.

1.34 Noisy Work Hours of Operation

- .1 In existing building, perform noisy work outside of normal business hours and conform to Municipal noise By-Laws.

1.35 Fire Safety Plan and Manual

- .1 Provide Fire Safety Plans and Fire Safety Plan Manual in strict accordance with Vancouver Building By-Law and other municipal and provincial regulations.

1.36 Project Closeout

- .1 Final Cleaning
 - .1 Remove waste materials and debris from site at regularly scheduled times or dispose of as directed by Consultant. Do not burn waste materials on site, unless approved by Consultant.
 - .2 Leave work “broom clean” before inspection process commences.
 - .3 Broom clean and wash exterior walks, steps and surfaces.
 - .4 Remove dirt and other disfigurations from exterior surfaces.
- .2 Documents
 - .1 Collect reviewed submittals and assemble documents executed by Subcontractors, suppliers, and manufacturers.
 - .2 Submit material prior to final Application for Payment.
 - .3 Submit operation and maintenance data, record (as-built) drawings.
 - .4 Provide warranties and bonds fully executed and notarized.
 - .5 Execute transition of Performance and Labour and Materials Payment Bond to warranty period requirements as applicable.
 - .6 Submit a final statement of accounting giving total adjusted Contract Price, previous payments, and monies remaining due.
 - .7 Consultant will issue a final change order reflecting approved adjustments to Contract Price not previously made.
- .3 Inspection/Takeover Procedures
 - .1 Prior to application for certificate of Substantial Performance, carefully inspect the Work and ensure it is complete, that major and minor construction deficiencies are complete, defects are corrected and building is clean and in condition for occupancy. Notify Consultant in writing, of satisfactory completion of the Work and request an inspection.
 - .2 During Consultant inspection, a list of deficiencies and defects will be tabulated. Correct same.
 - .3 When Consultant considers deficiencies and defects have been corrected and it appears requirements of Contract have been performed, make application for certificate of Substantial Performance.

End of Section

ISSUED FOR
1 4/19/13 Issued for Tender

METRIC
THIS DRAWING IS COPYRIGHTED AND MUST NOT BE USED, REPRODUCED, OR REVISED WITHOUT WRITTEN PERMISSION.
ALL DIMENSIONS ARE IN MILLIMETERS UNLESS OTHERWISE NOTED. VERIFY DIMENSIONS. DO NOT SCALE THIS DRAWING.
REPORT INCONSISTENCIES AND OMISSIONS TO THE CONSULTANT FOR CLARIFICATION BEFORE COMMENCING WITH THE WORK.
DEVIATIONS FROM THE CONTRACT DOCUMENTS WITHOUT WRITTEN APPROVAL FROM THE CONSULTANT ARE SUBJECT TO CORRECTION AT THE CONTRACTOR'S EXPENSE.

ARCHITECT & PRIME CONSULTANT
DIALOG BC ARCHITECTURE ENGINEERING
INTERIOR DESIGN PLANNING INC.
406 - 611 ALEXANDER STREET
VANCOUVER, BC, V6A 1E1
Tel: (604) 255-1169 Fax: (604) 255-1790
design@designdialog.ca

STRUCTURAL ENGINEER
EQUILIBRIUM CONSULTING INC.
202 - 388 WEST 8TH AVENUE
VANCOUVER, BC, V5Y 3X2
Tel: (604) 730-1422 Fax: (604) 738-8191

SEAL

Granville Island
Public Market Patio
Plan + sections

DRAWN: SL CHECKED: SL
PLOT DATE: 4/22/13

A01

Contractor to contact consultants for clarification where site conditions deviate from drawings

All wood frame, heavy timber and glue-laminated timber elements to be pressure treated as specified in Struc notes (refer to S02)

Connection of new lighting to elec. panel (including revisions to existing equipment and / or installation of new equipment) to be coordinated on site and be included in bid

Visual Requirements:

- Comply with the following requirements for steel exposed to view; compliance will be judged from the closest in service reviewing distance.
- Make all sections true, straight, with no dents, bends or other noticeable damage.
- In addition to the structural requirements, make all connection details meet the aesthetic requirements of the Consultant.
- For all connections, respect the exposed nature of the element. Make all weld passes continuous with uniform bead size. Protect surrounding steel from damage due to weld spatter. Grind all welds to a smooth uniform surface to the approval of the Consultant.

****Note: galvanized steel to be exposed min. one year prior to field painting**

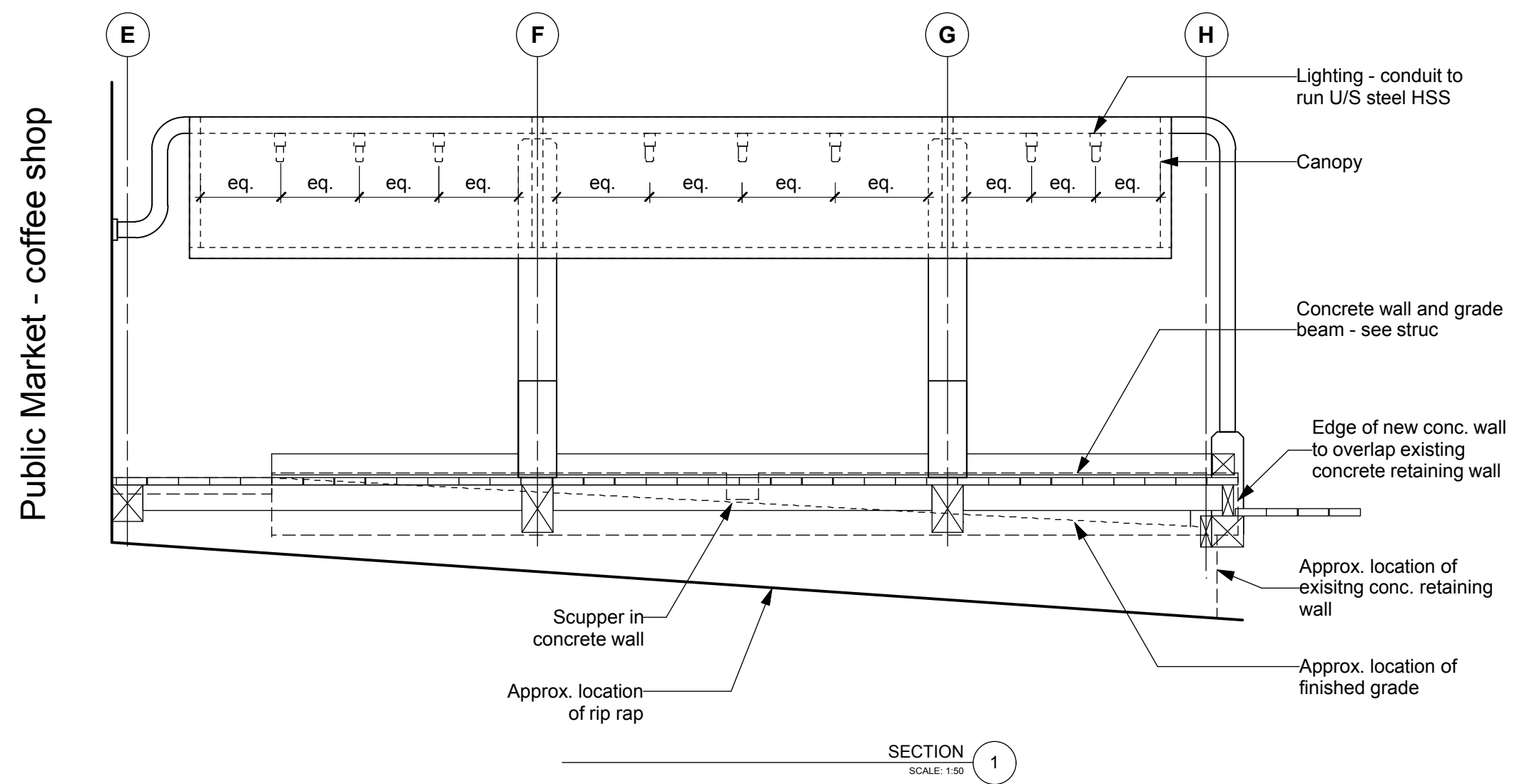
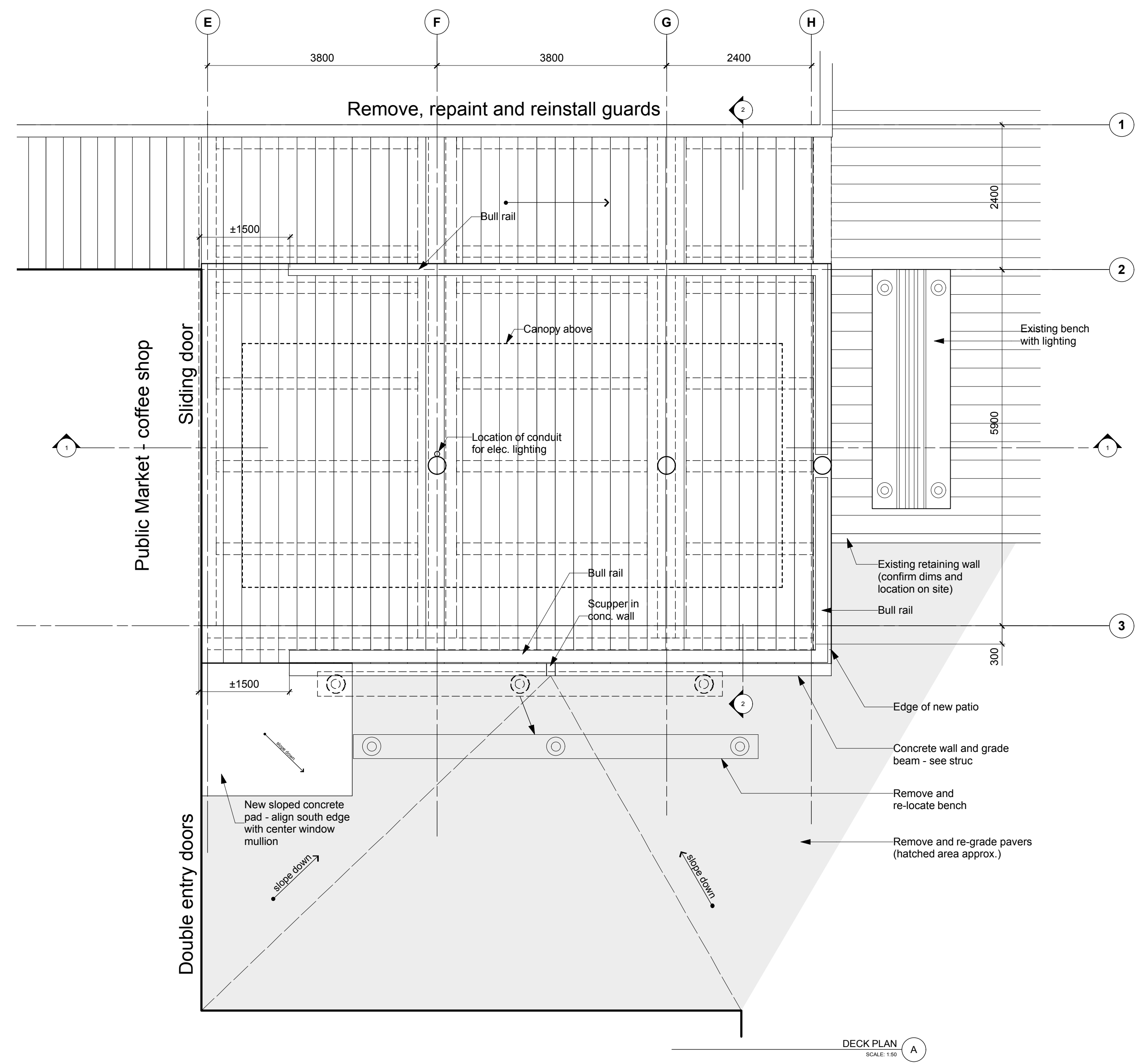
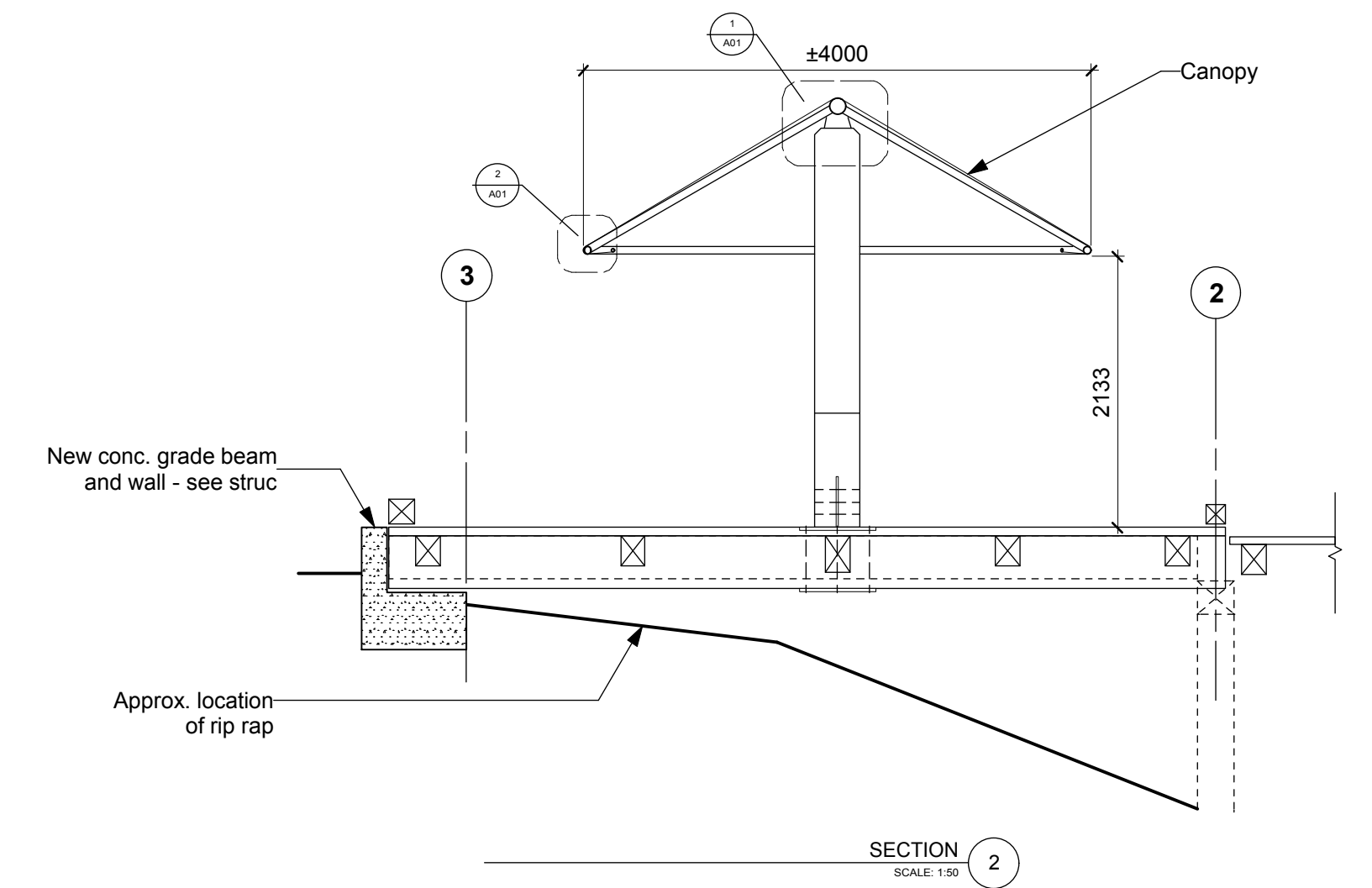
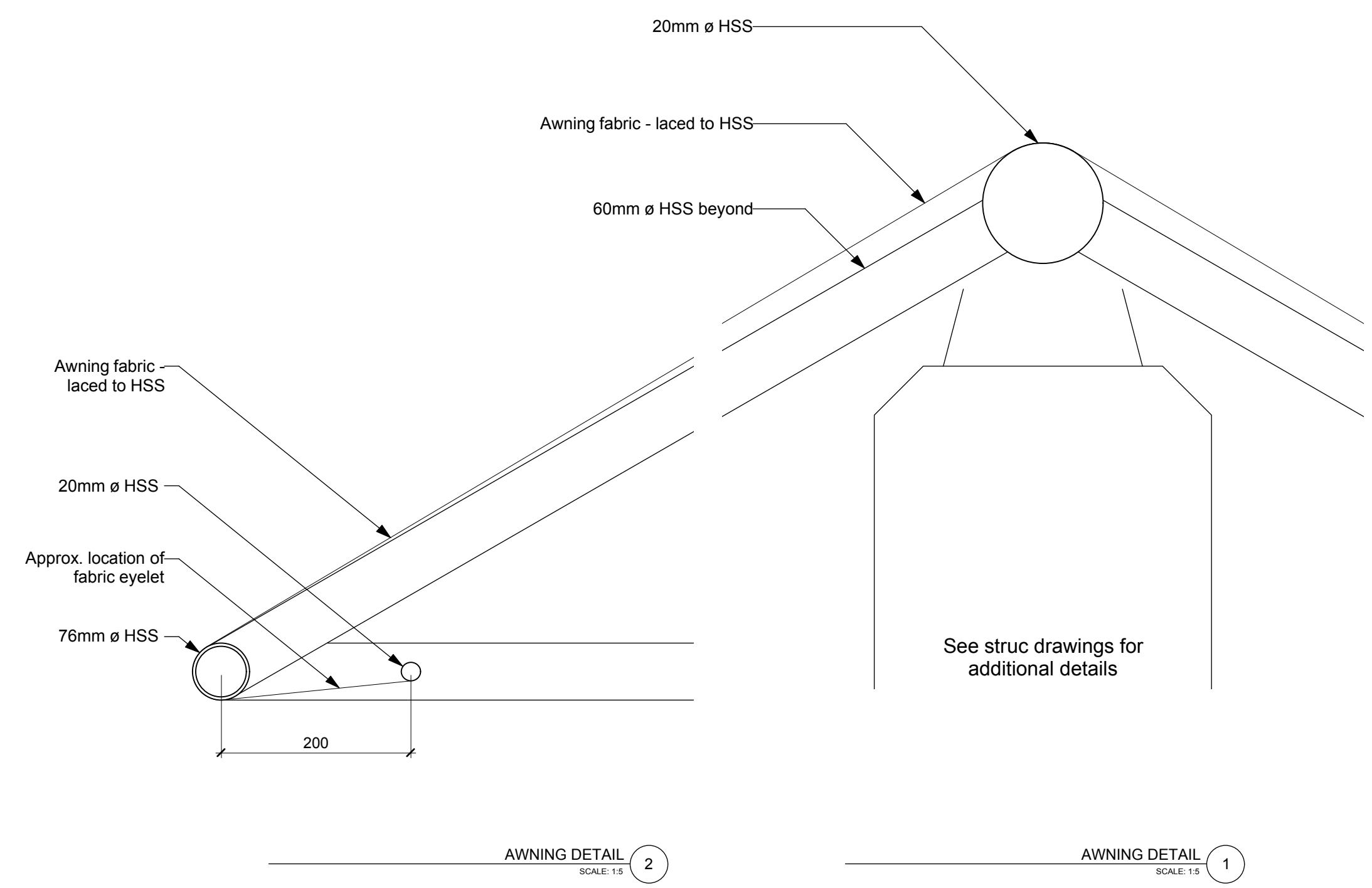

CONCRETE WALLS

- Refer to Architectural drawings for locations and dimensions of concrete upstand walls, planter walls, and curbs.
- Wall reinforcing shall be continuous unless noted otherwise. Use hooks or corner bars at all wall junctions and extend to top face of wall. Locate corner bars on outside face or center of wall, and embed vertical bars in main structure.
- Horizontal and vertical splices shall be Class B - Case 1 tension splices. Horizontal bars do not need to be considered as top bars unless noted otherwise.
- Lap 2-15M vertical at 625 mm (2 ft.) at ends of walls unless noted otherwise.
- Provide 2-15M parallel to all wall edges and extend 625 mm (2 ft.) beyond corners at openings in walls.
- Provide dowels at bottoms of walls at footing or where wall begins and hook if necessary. Dowels shall match vertical steel reinforcing.
- Provide U-bars at locations where floors are supports from the bottom of walls unless noted otherwise.
- Retaining walls below grade and exterior walls exposed to weather above grade shall have control joints. Submit locations of control joints in exposed concrete to the Architect for review and approval. Construction joints may replace control joints where required.
- Tops of walls shall be placed 0 mm (0") to 12 mm (1/2") below soffit of supported concrete structure unless noted otherwise. Carefully chip down any tops of walls placed above soffit as required by the Structural Engineer.

STRUCTURAL STEEL/METALS

- All structural steel work shall conform to CAN/CSA-S16-01.
 - All structural steel material shall conform to CSA-G40-20-04/G40-21-04 with the following grades:
 - a) Rolled shapes and plates: - 350W, W, WWF, S, T shapes
 - b) C, MC, HP shapes
 - c) Angles
 - d) HSS shapes (Class C)
 - e) Pipe sections
 - f) Bolts
 - g) Anchor rods & misc hardware
 - Design forces shown on drawings for all structural steel elements are factored vertical shear forces unless noted otherwise. Refer to "General Notes" and plans for applied design loads and definitions of live load, dead load, and superimposed load. Units for design forces are as follows:
 - a) Forces - kN
 - b) Moments - kNm
 - c) Line Loads - kN/m
 - d) Distributed Loads - kPa
 - All welding shall conform to CSA-W59-03 and to be performed by welders under CSA-W47-1-03, fabricators to CWB approval.
 - Welds shall be E-70xx. Filled welds shall be 6mm minimum. Nelson Stud welding shall meet specifications of manufacturer.
 - Install all welded headed studs and welded deformed bar anchors according to manufacturer's specifications or shop filed weld. Field filled welded headed studs and deformed bar anchors will be rejected. The Contractor shall be responsible for coordinating the design, supply and installation of all studs and anchors. Refer to Structural drawings for locations and details of welded studs and anchors.
 - Provide 16 mm (5/8") column cap plates and 20 mm (3/4") column base plates unless noted otherwise.
 - Provide 6 mm (1/4") cap plate for HSS members unless noted otherwise.
 - Unless noted otherwise, apply one shop coat of primer to all steel work, to CISC/CPMA 1-73A. Primer for exterior exposure shall be zinc-chromate Type 1, conforming to CGSB 1-GP-40d.
 - Where required, all hot dip galvanizing shall conform to CAN/CSA-G164-M92.
 - Unless noted otherwise, design structural steel connections for minimum half the shear or compression capacity of the members connected by the Fabricator's Engineer). Bolted connections shall consist of minimum 2-19 mm (2-3/4") A325 bolts with a 9.5 mm (3/8") connector plate.
 - Do not oversize holes in steel to fit any anchor locations unless noted otherwise. Follow standard practice of using slightly oversized holes in column base plates:
 - a) Use 6 mm (1/4") oversized hole diameter for column anchor rods up to and including 27 mm (1 1/8") diameter.
 - b) Use 12 mm (1/2") oversized hole diameter for column anchor rods greater than 27 mm (1 1/8") diameter.
 - Unless noted otherwise, design deck angle splice connections for minimum half the tension capacity of the members connected (by the Fabricator's Engineer).
 - Refer to shear connector notes for stud shear connections of all composite beams. Refer to Structural drawings for details of studs shown on structural elements other than composite beams. The contractor shall be responsible for the coordination of the design, supply, and installation of all studs.
 - Moment connected beams through supporting beams or columns are designated by the following symbol:
- Provide full moment connection unless noted otherwise.
- Refer to typical details in the general notes for support framing of roof top mechanical equipment unless noted otherwise. Frame roof and floor openings greater than 450 mm (1'-6") according to typical details unless noted otherwise on plans.
 - Confirm roof and floor elevations, roof slopes, edge details, and additional dimensions and details with Architectural drawings. Also refer to Mechanical and Electrical drawings for design details.
 - All exposed steel work to be quality appearance to the Consultant's approval and in accordance with Architectural specifications and CAN/CSA-S16-01.
 - The Contractor shall notify the consultant in writing, prior to submission of shop drawings, as to which Engineer will be responsible for providing field review for the connections and components designed by the Contractor.
 - The Contractor shall notify the Structural Engineer in writing, prior to the submission of shop drawings, that the fabricator is certified to a minimum of Division 2.1 of CAN/CSA-W47.1.
 - Submit PDF shop drawings for the above to the Structural Engineer for review prior to fabrication. All shop drawings shall show all details, indicate all applicable design loads and material specifications, and be sealed by the fabricator's engineer (a P-Eng registered in B.C.).
 - All beam connections shall be standard frame beam connections or equivalent, unless noted otherwise. The Fabricator shall be responsible for the design of all standard connections unless noted otherwise, and shall submit detailed design drawings with associated design capacities in addition to regular shop drawings for review. Detailed standard connection drawings are to precede regular shop drawings.
 - The Specialty Structural Engineer shall be responsible for the preparation of shop drawings and field review of components and connections designed by the Fabricator. When satisfied at the end of field review, the Specialty Engineer shall provide a sealed letter (schedule S) to the Structural Engineer ensuring that constructed work conforms to shop drawings, as well as provide sealed sketches for all field modifications made to designs.
 - The Fabricator's Specialty Structural Engineer shall sign and seal all shop drawings of components and connections designed by said Engineer. Alternatively, a signed and sealed letter detailing what was designed, including a list of final drawings with revision dates and numbers may be substituted in place of sealed shop drawings.
 - Connections and splices not shown on structural drawings and requested by fabricator must be detailed on shop drawings and receive written approval from the Structural Engineer. Testing of connection and splices is subject to the discretion of the Structural Engineer at the expense of the Contractor.

STRUCTURAL STEEL/METALS continued

- The Contractor shall not alter connection details shown on the Structural drawings without written approval from the Structural Engineer.
 - Refer to CAN/CSA-S16-01 for general seismic requirements for:
 - a) Connection design for connection forces - Clause 27 not shown on drawings
 - b) Steel in the energy dissipation system - Clause 27.1.5.
 - c) Welds and weld material - Clause 27.1.5.3.
 - d) Bolted connections - Clause 27.1.6.
 - Welding of reinforcing to embedded plates is permitted only with weldable deformed bar anchors with the following fillet weld sizes:

BAR Ø	WELD SIZE
10M (3/8")	6mm (1/2")
15M (5/8")	10mm (3/8")
20M (3/4")	12mm (1/2")
 - Grout fill voids on underside of all base plates and bearing plates in contact with concrete or masonry with a plastic consistency non-shrink grout with a minimum 7 day strength of 45 MPa (6500 psi). Follow manufacturer's specifications and instructions for mixing and placement.
 - Beam and girder connections to embedded plates shall be double angle framing connections unless noted otherwise.
 - Design beam and girder connections for shear based on the member's full moment resistance to a uniformly loaded and simply supported span unless noted otherwise.
 - The top flanges of beams shall be clear of paint, dirt, heavy rust, and any other materials that may interfere with welding of stud shear connection and steel deck to beams.
 - Provide full height and full width 10mm (3/8") stiffener plates each side over column where beams sit over columns unless noted otherwise.
 - See Architectural drawings for miscellaneous steel components. Any steel components not shown on the Structural drawings are considered to be Secondary Components (see notes on Secondary Components and Their Attachments). Assume 6mm (1/4") unless noted otherwise.
- Fabrication:
 - Fabrication shall be handled with special care and necessary straightening to maintain the condition of the material.
 - Shop drawings shall clearly detail the required fabrication tolerances. Erection plans and/or anchor bolt plans shall show the required tolerances for setting embedded items.
 - Copes, mitres and butt cuts in exposed surfaces shall be made with uniform gaps of 3 mm (1/8") if shown on Architectural drawings as open joints, or in uniform contact if shown on drawings without a gap.
 - Welding:
 - Filler welds:
 - Finishing or grinding of exposed weld faces is not required except where noted on drawings or where clearances or fit of other items is necessary. Weld faces shall be reasonably smooth and uniform and shall have as-welded surfaces.
 - Butt and plug welds:
 - Finishing or grinding of exposed butt and plug weld faces is not required except where noted on drawings or where clearances or fit of other items is necessary. Butt and plug weld faces shall be reasonably smooth and uniform with as-welded surfaces, and shall not project more than 1.5 mm (1/16") above the surfaces joined.
 - Painting:
 - Do not paint surfaces within 50 mm (2") of any field weld location. Keep this area clear of materials that might prevent proper welding or produce objectionable fumes while welding. If shop painted, wire brush in the field all surfaces to be welded.
 - Erection:
 - The erector shall use special care in unloading, handling, and erecting the steel to avoid bending, twisting, damage to shop coat of paint, or otherwise distorting the steel members.
 - The erector shall ensure that the close fit and near appearance of the joints and structure as a whole is not impaired during erection.
 - Use special care when removing temporary braces or erection clips to avoid damage to the structure's appearance. Ground smooth tack welds and fill holes with weld metal or body solder smoothed by grinding or filing.
 - Paint all areas scratched, marred, or left unpainted for erection purposes.

WOOD FRAME

- All work shall conform to the latest edition of CSA Standard 086 and referenced documents.
- Confirm all dimensions, outlines, elevations, and details with Architectural drawings.
- Unless noted otherwise, joists, timber beams, built-up beams, built-up posts, edge laminated floors, and stud framing including top and bottom plates shall be KD SPF No. 2 or better. Solid wood posts shall be D-Fir No. 1.
- Any timber not grade marked will be rejected.
- The use of finger-jointed studs will not be permitted in load-bearing walls.
- Unless noted otherwise, all framing, bridging, blocking and nailing shall be in accordance with Part 8 of the Building Code as per "GENERAL" on this drawing. Provide 38x38 [2x2] bridging at 2100 mm [7'-0"] on center for all spans greater than 3000 mm [10'-0"], with 13 mm [1/2"] gap between bridging.
- Built-up beams and posts shall consist of minimum 2 members. Minimum lintel shall be 1-89x241 [3 1/2"x9 1/2"] LSL (TimberStrand) or 2-38x235 [2-2x10] unless noted otherwise.
- Laminate studs solid beneath all beam-ends and carry through to concrete foundation below. Unless noted, built-up beams shall match number of laminations in built-up member being supported. Fully block all joint spaces below point loads. Take care to ensure beams bear fully on supporting members.
- Install double cripples under lintels unless noted otherwise.
- Joists are minimum 38x235 @ 400 [2x10 @ 16"] on center unless noted otherwise. Install double joists under parallel non-load bearing partitions above.
- Unless noted otherwise, use Simpson connectors or equivalent where required. All nail holes in connectors, including straps, to be filled with nail type specified by the hardware supplier. Use joist hangers (minimum 1000 lbs capacity) or fully nailed pressure block for all flush framing.
- Steel hardware shall be ASTM A36 or better and bolts shall be A307, hot dipped galvanized. All steel components in timber connections for exterior applications to be hot dipped galvanized. All bolts and lag bolts bearing against timber shall have standard "CUT" (oversized) washers uno.
- Lag bolts shall have thread over minimum half the bolt length, and shall have sharp threads. Dull thread lag bolts with insufficient thread length will be immediately rejected. All lag bolts to be machined threaded, not cast threaded.
- Re-tighten all accessible bolts where timber shrinkage may have occurred at end of project.
- All timber specified as "treated" to be pressure treated according to CSA-080 Series-08 (R2012) - Wood Preservation.
 - Wood accessible to regular user contact: This would include play structures, play area decks, guardrails, and other preserved wood surfaces that can be touched by the users on a regular basis. Treat using ACO or AC Vacuum Pressure impregnation to be 0.4 pcf or to refusal. Above deck members to meet use category UC3.2.
 - Wood not accessible to regular user contact: This would include structures concealed or not commonly accessible to user contact such as wall sill plates, sleepers, soil retaining structures and traffic decks. Treat using CCA Vacuum Pressure impregnation to be 0.4 pcf or to refusal. Below deck members to meet use category UC5A.
 - Field apply matching preservative to equivalent standard to all areas cut or drilled.
- Finishes shall be detailed to accommodate shrinkage of timber.
- Provide Type S roll roofing as a moisture barrier between wood elements and concrete or masonry.
- Any changes to the framing shown on these drawings shall have prior written approval of the Structural Engineer.

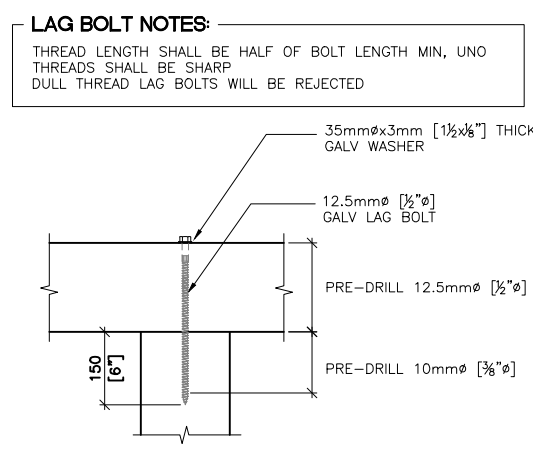

DETAIL - 12.5mm (5/8") LAG BOLT

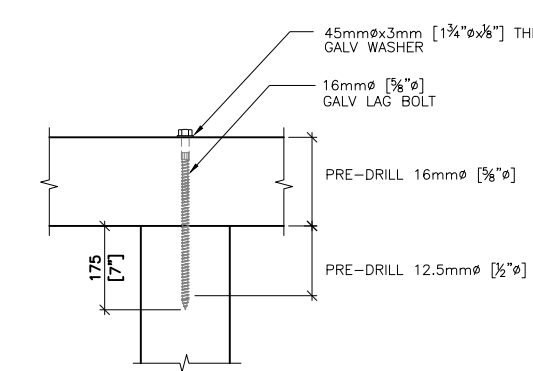

DETAIL - 16mm (5/8") LAG BOLT

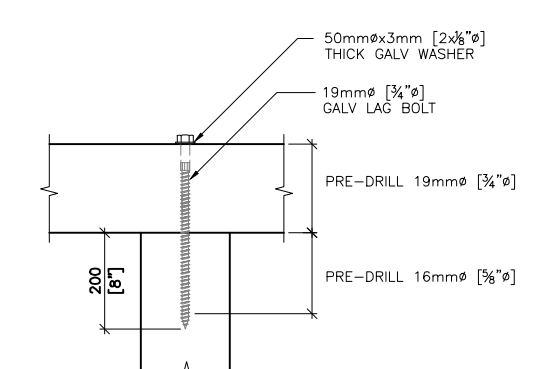

DETAIL - 19mm (3/4") LAG BOLT

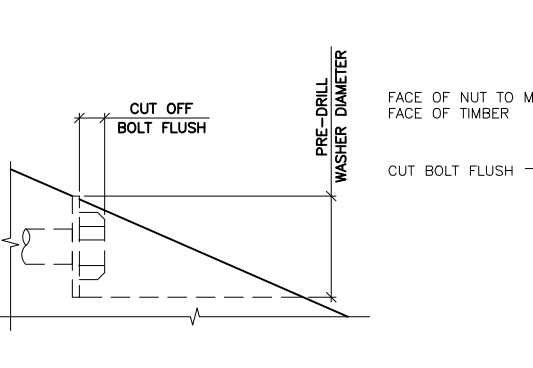

DETAIL - TYPICAL COUNTERSINK

HEAVY TIMBER

- All heavy timber design and construction to conform to CSA 086-01 documents.
- All heavy timbers to be graded by a qualified grading agency according to CAN/CSA-0141-01 (R1999). "Softwood lumber" grading certificate to be submitted to the Engineer prior to erection.
- All structural heavy timber to be Douglas Fir No.1 or better, planed.
- Logs to be D-Fir #1 or better, conforming to N.L.G.A. 131, free of through splits, minimal knots, knotted with +/-100mm (4") even facets. Diameter as indicated +/- 10 mm (3/8").
- Moisture content of dry wood (all members where tight fit connections are used and where specified on drawings) to be less than 19% in center of timber. It is the contractor's responsibility to submit a certificate stating moisture content from a qualified grading agency approved by the Engineer prior to the installation of tight fit pin connections. Recycled or re-sawn timber can be used where dry wood is specified. All wood to be kept dry during construction.
- Appearance requirements for all exposed timbers:
 - Wood surface to be free of large knots, cracks, chips, marks, etc. To avoid staining, do not use steel strapping.
 - All timbers to be of uniform colour, surface texture and moisture content
 - All timbers to be free of rounded edges and bark (no wane)
 - All timbers not to contain centre of log - free of heart centre-recommended
- Contractor to ensure no damage or marking to be caused by handling and delivery of material.
- All lag bolts, thru-bolts and other hardware to be hot dipped galvanized.
- All heavy timbers (columns optionally) containing heart centre material to be kerfed to mid depth over the full length of member before the wood dries and shrinkage cracks appear. Kerfing in beams to be vertical and oriented upwards.
- Contractor to prepare shop drawings of all heavy timber elements and submit for approval to the engineer prior to purchase of timbers and fabrication.
- All timber within 400mm [16"] of existing grade to be pressure treated according to CSA-080 Series-07 (R2002). "Above deck members to meet use category UC3.2. Below deck members to meet use category UC5A. All cutting and drilling to be completed before the treatment. Field apply preservative to equivalent standard, to all areas cut or drilled.
- Store all timber elements off the ground with spacer blocks between members. Keep wrapping on the members until permanent protection from the weather is in place, but cut holes on the underside of the wrapping to prevent accumulation of condensation.
- The use of metal bundling straps is prohibited.
- At end of project re-tighten all accessible bolts where timber shrinkage may have occurred.

GLUE-LAMINATED TIMBER: GLULAM (GL)

- All work to CSA Standard 086 and referenced documents.
- Glulam members shall be Douglas Fir 24f-E (24f-E for cantilever or continuous beams) stress grade with quality appearance grade and 15% max. moisture content. Industrial appearance grade may be used where beams are to be concealed.
- Glulam manufacturer must qualify under CAN/CSA-O177-M89 (R2003).
- If certified by the American Plywood Association - Engineered Wood Systems (APA EVS) to bond with this product, provide alternate price for full glulam package with polyurethane resin (white) adhesive meeting the requirements of ANSI A190.1-1992, DIN 68 141 and EN 301 and 302.
- Camber simple span beams 10mm (3/8") per 3000 (10'-0") of span.
- Submit PDF shop drawings showing all applicable details and material specifications to the Engineer for review prior to fabrication. Shop drawings shall be accompanied by a certificate of conformance to manufacturing standard.
- Affix authorized label to all members supplied. Also identify each member with mark number.
- Store glulam off the ground with spacer blocks placed between members. Keep wrapping on the members until permanent protection from the weather is in place but cut holes on underside of wrapping to prevent the accumulation of condensation.
- All pressure treated glulam to be treated according to CAN/CSA-080 Series-08 (R2012) - Wood Preservation. * All cutting and drilling to be completed before the treatment. Field apply preservative to equivalent standard, to all areas cut or drilled.
- All structural steel connected glulam elements to each other and to supporting members shall be detailed, supplied and test fitted in the shop by the glulam supplier.
- In transition area between wood elements and concrete or masonry, wood elements to be protected from ascending moisture. Provide light-gauge metal, asphalt-impregnated building paper, closed-cell foam gasket material, type S roll roofing, or 0.05 mm polyethylene as a moisture barrier.
- Finish of concealed / below deck members: see Architectural for details. Members to meet use category UC5A.
- Finish of exposed / above deck members: see Architectural for details. Members to meet use category UC3.2.
- Re-tighten all accessible bolts at end of project.
- Shop drawings of connections and components designed by the Contractor shall be signed and sealed by the Specialty Engineer and submitted with a statement of product compliance with drawing specifications and standards.

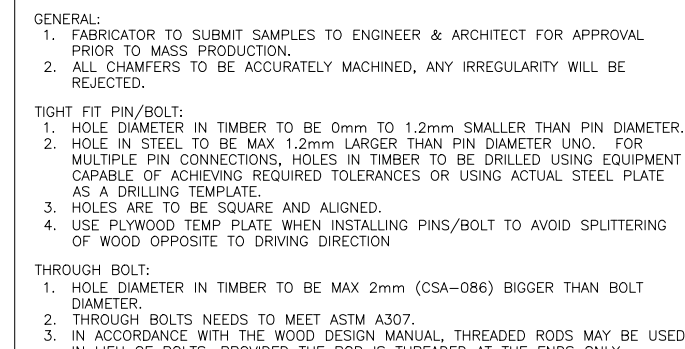
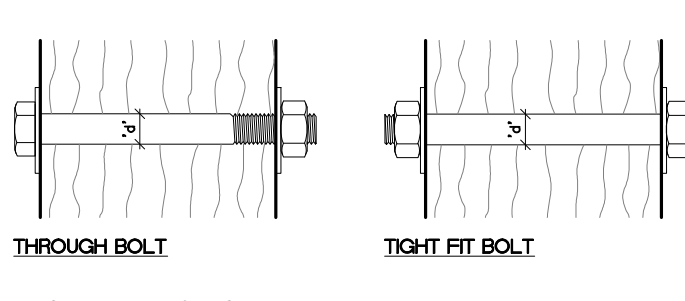
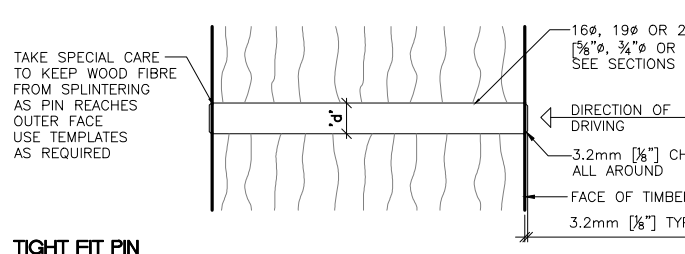
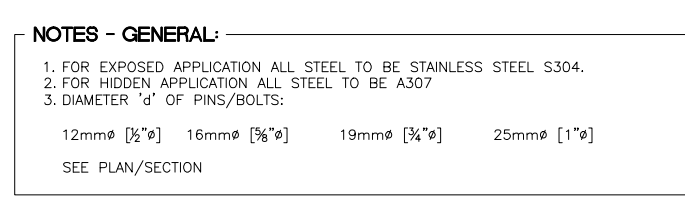

STEEL PARTS FOR WOOD CONSTRUCTION

TIMBER FASTENERS and BEARING STRIPS

- The following **partially threaded** self tapping screws are acceptable, unless specified on structural drawings:

MANUFACTURER	FASTENER TYPE
SFS Intec	SFS WFC-T SFS WFR-T
GRW Fasteners HECO SWG (Würth)	R4™ Multi Purpose Screw TOPIX (tapered screw head UNO) ASSY 3.0 SK ASSY 3.0 KOMBI
- The following **fully threaded** self tapping screws are acceptable, unless specified on structural drawings:

MANUFACTURER	FASTENER TYPE
SFS Intec	SFS WT-T SFS WR-T
HECO	TOPIX CC (Tapered screw head UNO)
SWG (Würth)	ASSY plus VG
- Screw types specified on structural drawings supersede the information above unless noted otherwise.
- Where partially threaded and/or fully threaded self tapping screws are used in combination with architecturally exposed steel plates, use screws with tapered screw head unless noted otherwise. Countersink holes in steel to receive tapered screw heads. Do not oversize holes. Contractor to submit sample of steel plate including screw used in assembly to Equilibrium Consulting for approval prior to mass fabrication.
- Where partially threaded and/or fully threaded self tapping screws are used in combination with steel plates to be exposed to view, use screws with a hex head in place, but cut holes on the underside of the wrapping to prevent accumulation of condensation.
- Elevators.
- Architectural precast and precast cladding.
- Window washing equipment and its attachments.
- Interior and exterior light gauge steel stud walls.
- Roofing material.
- Architectural brick veneer.
- Design and detailing of the above items and their attachments are not the responsibility of the Engineer. They shall be designed by specialty structural engineers retained by Contractor, who will seal all related shop drawings, review the components in the field and provide all required sealed letters to the authorities having jurisdiction. Contractor to obtain design before completing the structural portions of the building that will receive these secondary components.
- Secondary or non-structural components and their attachments shall be designed in accordance with Part 4 of the Building Code as per Note #8 in "GENERAL" on this drawing.
- Sealed shop drawings of the secondary or non-structural components which may affect the primary structural system shall be submitted to the Engineer only for the review of their effect on the primary structural system. Clearly indicate the method and means of attachment and the magnitude of forces that the structure must withstand. Review by the Engineer of Record may result in the need to modify the means of connection. Subcontractor of these components is responsible for protection of aluminum-steel connections against galvanic corrosion.
- In addition to construction tolerance, non-structural components shall be detailed for the following building movement and deflection:
 - Vertical deflections of beams, slabs and decking:
 - Differential deflections of edge beams and edges of slabs:
 - Horizontal drift during wind and earthquake between floors:
 - Drift without damage to non-structural components: ± 13mm (1/2")
 - Drift without collapse of non-structural components: ± 50mm (2")
 - Movement at expansion joints:
 - Perpendicular: ±50mm (2")
 - Parallel: ±50mm (2")
 - Vertical: ±25mm (1")



CONSULTING STRUCTURAL ENGINEERS

202-388 West 8th Ave. tel: 604 730-1422
Vancouver, B.C. fax: 604 738-8190
V5Y 3X2 info@equanad.com

This drawing as an instrument of service is the property of Equilibrium Consulting Inc. and may not be reproduced without the firm's permission. All information shown on the drawing is for the use in this specific project only and shall not be used otherwise without written permission from this office. Contractors shall verify and be responsible for all dimensions on the job and this office shall be informed of any discrepancies and variations shown on this drawing.

Project

PUBLIC MARKET PATIO GRANVILLE ISLAND VANCOUVER, BC

SECONDARY COMPONENTS AND THEIR ATTACHMENTS

- Secondary components include but are not limited to the following:
 - Architectural components, including embeds, such as guard and hand rails, beam posts, canopies, ceilings, etc.
 - Site work elements exterior to the base building such as landscaping components, pools, signs, and civil work.
 - Cladding, window mullions, glazing and store fronts.
 - Skylights and glass canopies.
 - Attachments and bracing for electrical and mechanical components.
 - Glass block including attachments.
 - Elevators.
 - Architectural precast and precast cladding.
 - Window washing equipment and its attachments.
 - Interior and exterior light gauge steel stud walls.
 - Roofing material.
 - Architectural brick veneer.
- Design and detailing of the above items and their attachments are not the responsibility of the Engineer. They shall be designed by specialty structural engineers retained by Contractor, who will seal all related shop drawings, review the components in the field and provide all required sealed letters to the authorities having jurisdiction. Contractor to obtain design before completing the structural portions of the building that will receive these secondary components.
- Secondary or non-structural components and their attachments shall be designed in accordance with Part 4 of the Building Code as per Note #8 in "GENERAL" on this drawing.
- Sealed shop drawings of the secondary or non-structural components which may affect the primary structural system shall be submitted to the Engineer only for the review of their effect on the primary structural system. Clearly indicate the method and means of attachment and the magnitude of forces that the structure must withstand. Review by the Engineer of Record may result in the need to modify the means of connection. Subcontractor of these components is responsible for protection of aluminum-steel connections against galvanic corrosion.
- In addition to construction tolerance, non-structural components shall be detailed for the following building movement and deflection:
 - Vertical deflections of beams, slabs and decking:
 - Differential deflections of edge beams and edges of slabs:
 - Horizontal drift during wind and earthquake between floors:
 - Drift without damage to non-structural components: ± 13mm (1/2")
 - Drift without collapse of non-structural components: ± 50mm (2")
 - Movement at expansion joints:
 - Perpendicular: ±50mm (2")
 - Parallel: ±50mm (2")
 - Vertical: ±25mm (1")

19/04/13 ISSUED FOR TENDER

Rev. DY/MT/YR Issued

Drawing Title

GENERAL NOTES AND TYPICAL DETAILS

Date	MAY 2012
Scale	AS SHOWN
Drawn By	GS/RV
Checked By	RM/DR
Project No.	Drawing No.

11003 S02

This drawing as an instrument of service is the property of Equilibrium Consulting Inc. and may not be reproduced without the firm's permission. All information shown on the drawing is for the use in this specific project only and shall not be used otherwise without written permission from this office. Contractors shall verify and be responsible for all dimensions on the job and this office shall be informed of any discrepancies and variations shown on this drawing.

Project

PUBLIC MARKET PATIO
GRANVILLE ISLAND
VANCOUVER, BC

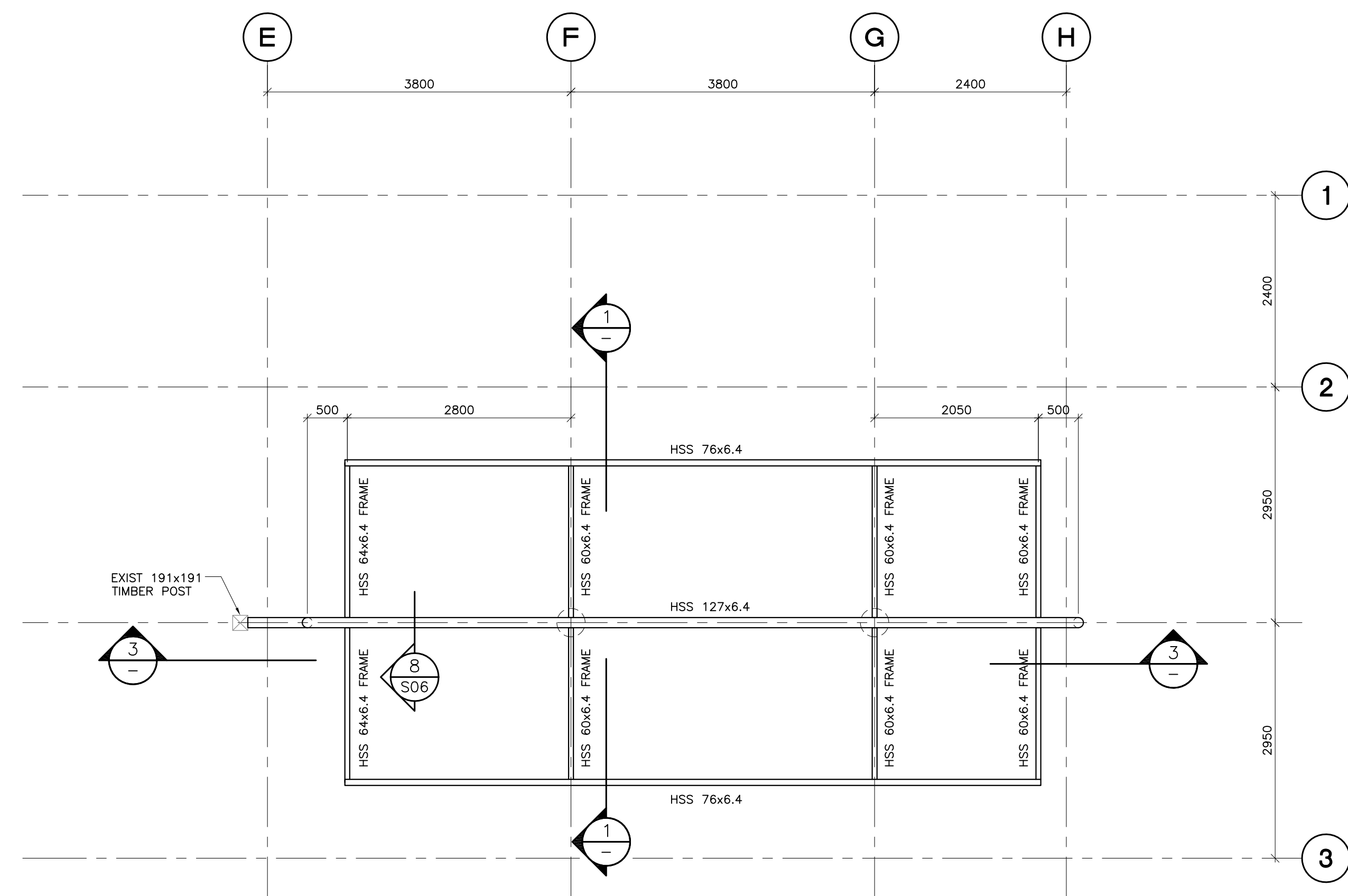
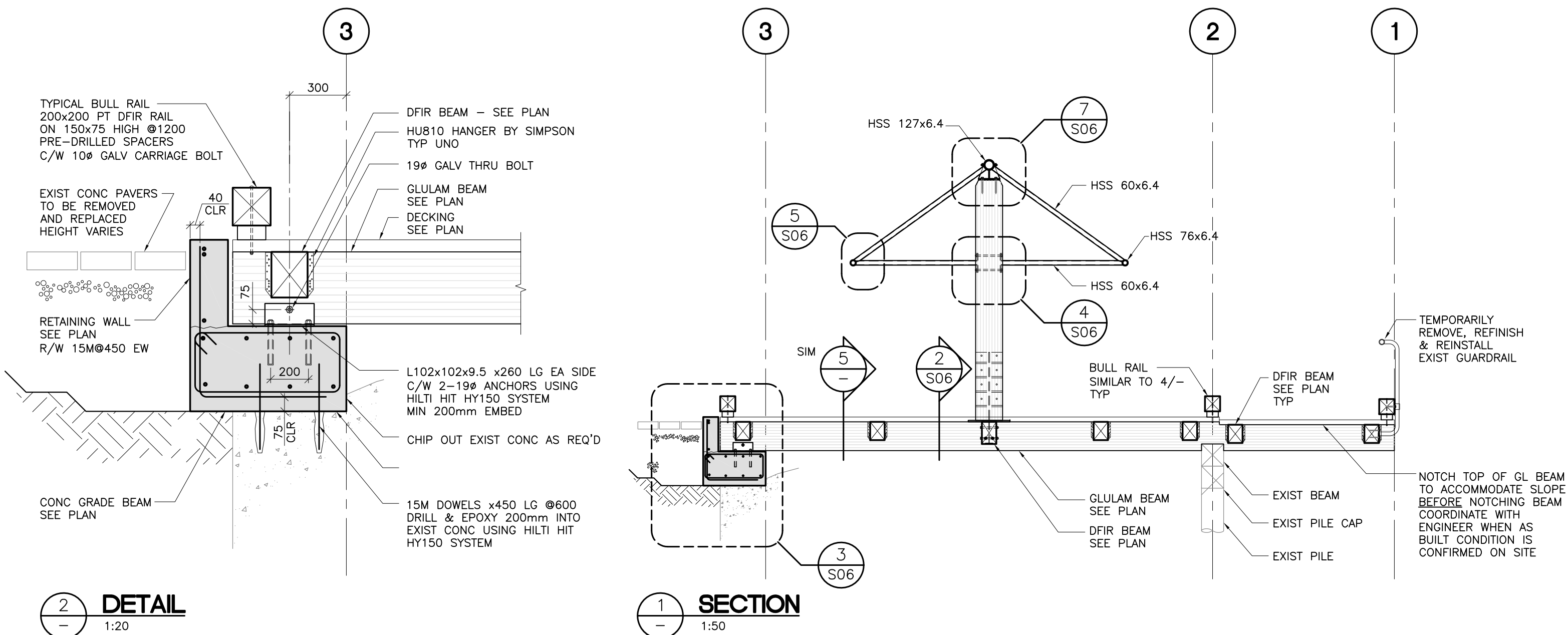
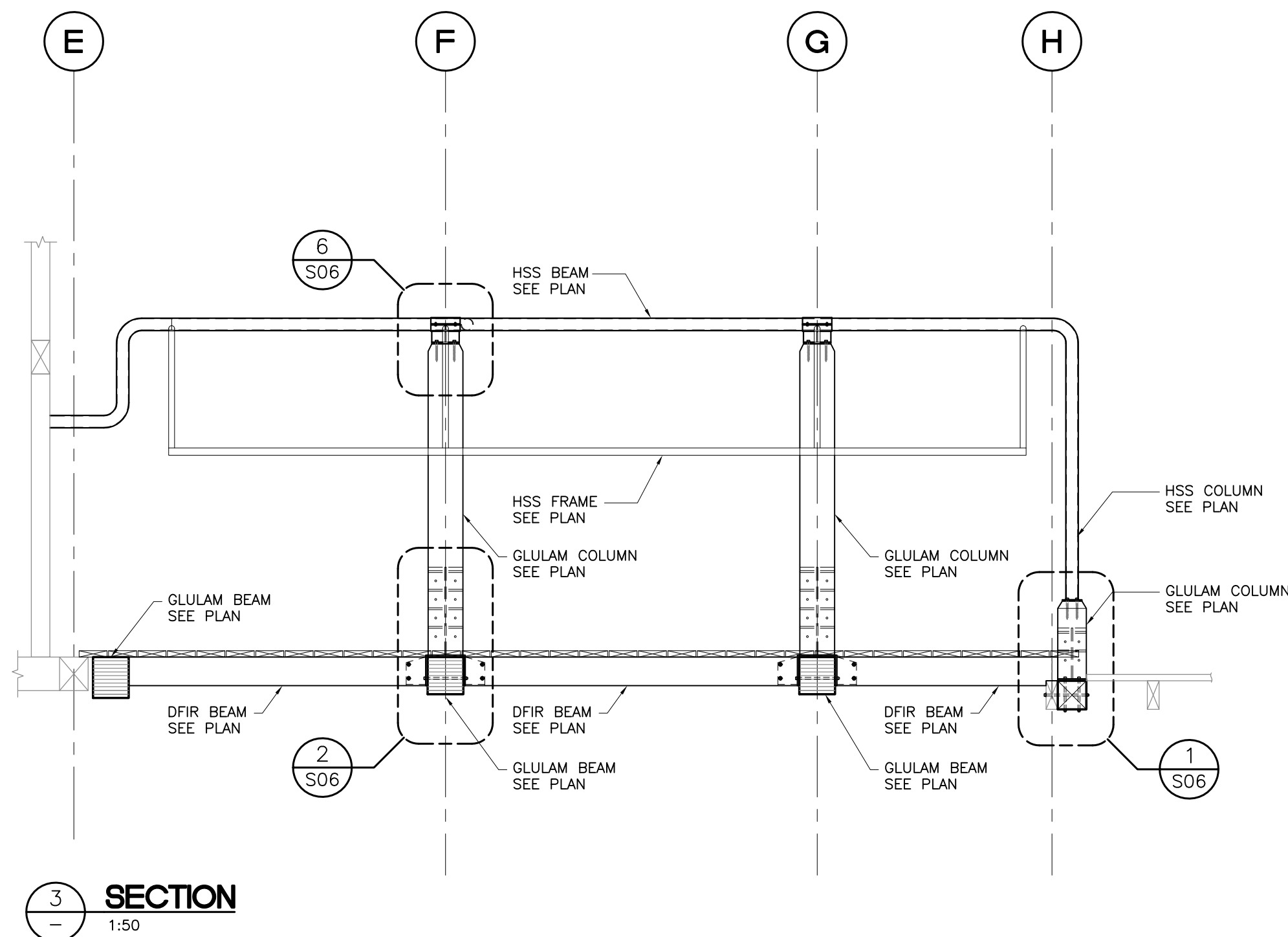
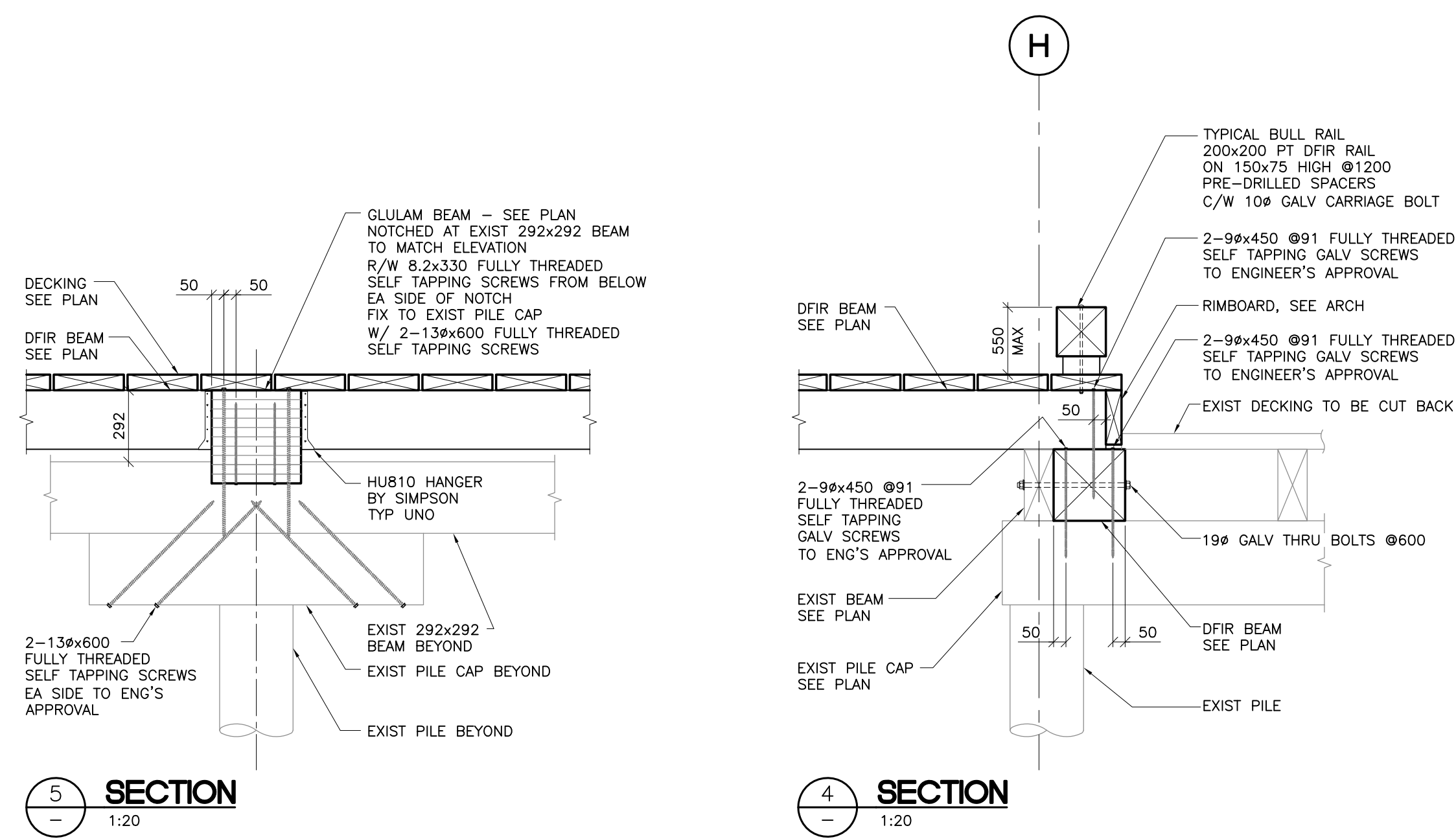

CANOPY PLAN
1:50

- IMPORTANT NOTES:**
1. REMOVE EXIST BEAMS ON GRIDS F & G AND EXISTING DECKING AND JOISTS BETWEEN GRIDS E-H/1-2. HAND OVER ALL REMOVED BEAMS AND DECKING TO OWNER.
 2. ALL STEEL PARTS TO BE HOT DIPPED GALVANIZED, TYP.
 3. ALL TIMBER AND GLULAM TO BE PRESSURE TREATED.
 4. ALL DIMENSIONS AND ELEVATIONS TO BE CONFIRMED ON SITE.
 5. ALL EXPOSED WELDS & FIELD WELDING TO BE GROUND SMOOTH.

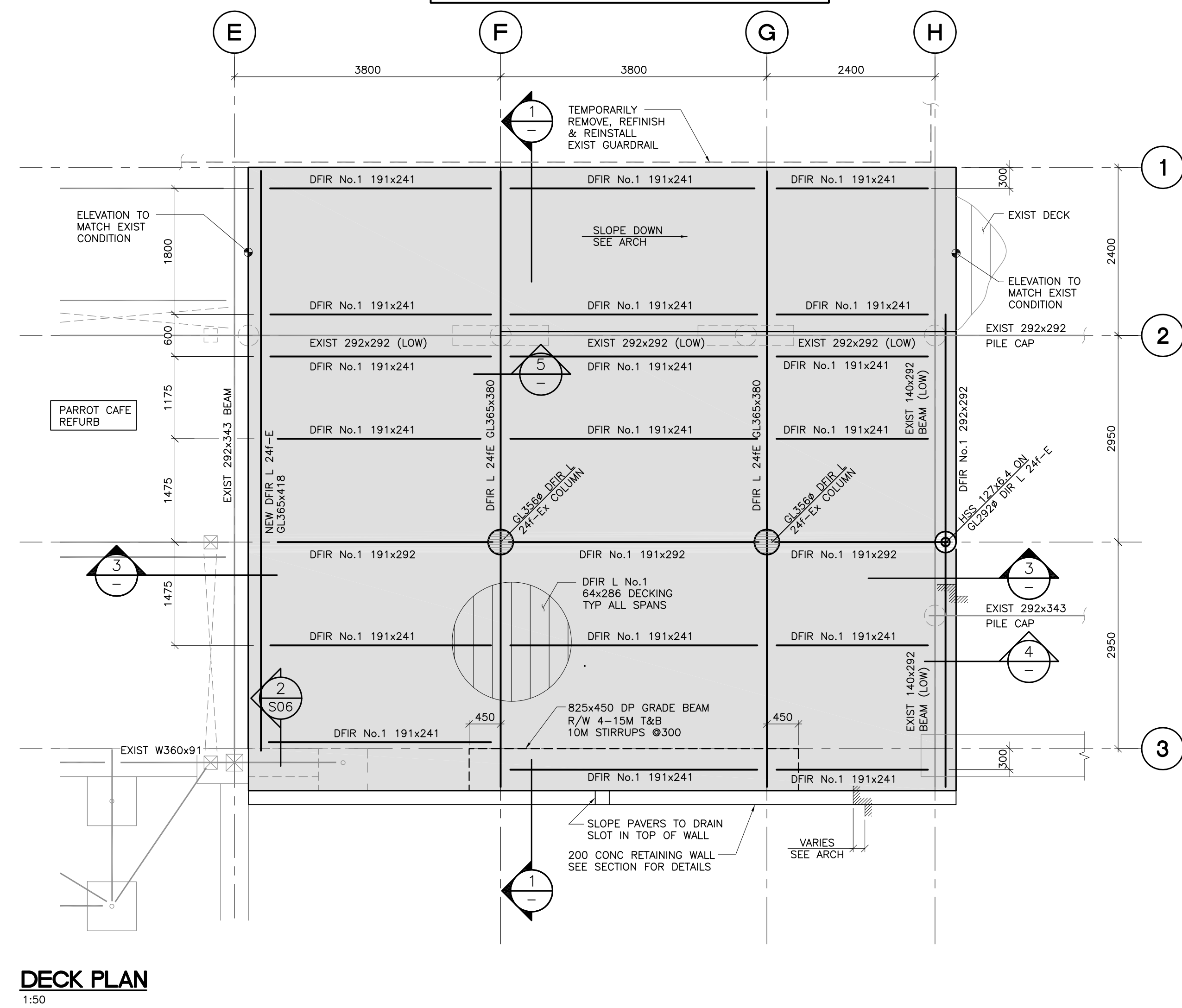

DECK PLAN
1:50

19/04/13 ISSUED FOR TENDER
11/05/12 ISSUED FOR COORDINATION
Rev. DY/MT/YR Issued

Drawing Title
**DECK PLAN,
CANOPY PLAN,
SECTIONS
AND DETAILS**

Date MAY 2012
Scale AS SHOWN
Drawn By GS/RV
Checked By RM/DR
Project No. Drawing No.

11003 S03

This drawing as an instrument of service is the property of Equilibrium Consulting Inc. and may not be reproduced without the firm's permission. All information shown on the drawing is for the use in this specific project only and shall not be used otherwise without written permission from this office. Contractors shall verify and be responsible for all dimensions on the job and this office shall be informed of any discrepancies and variations shown on this drawing.

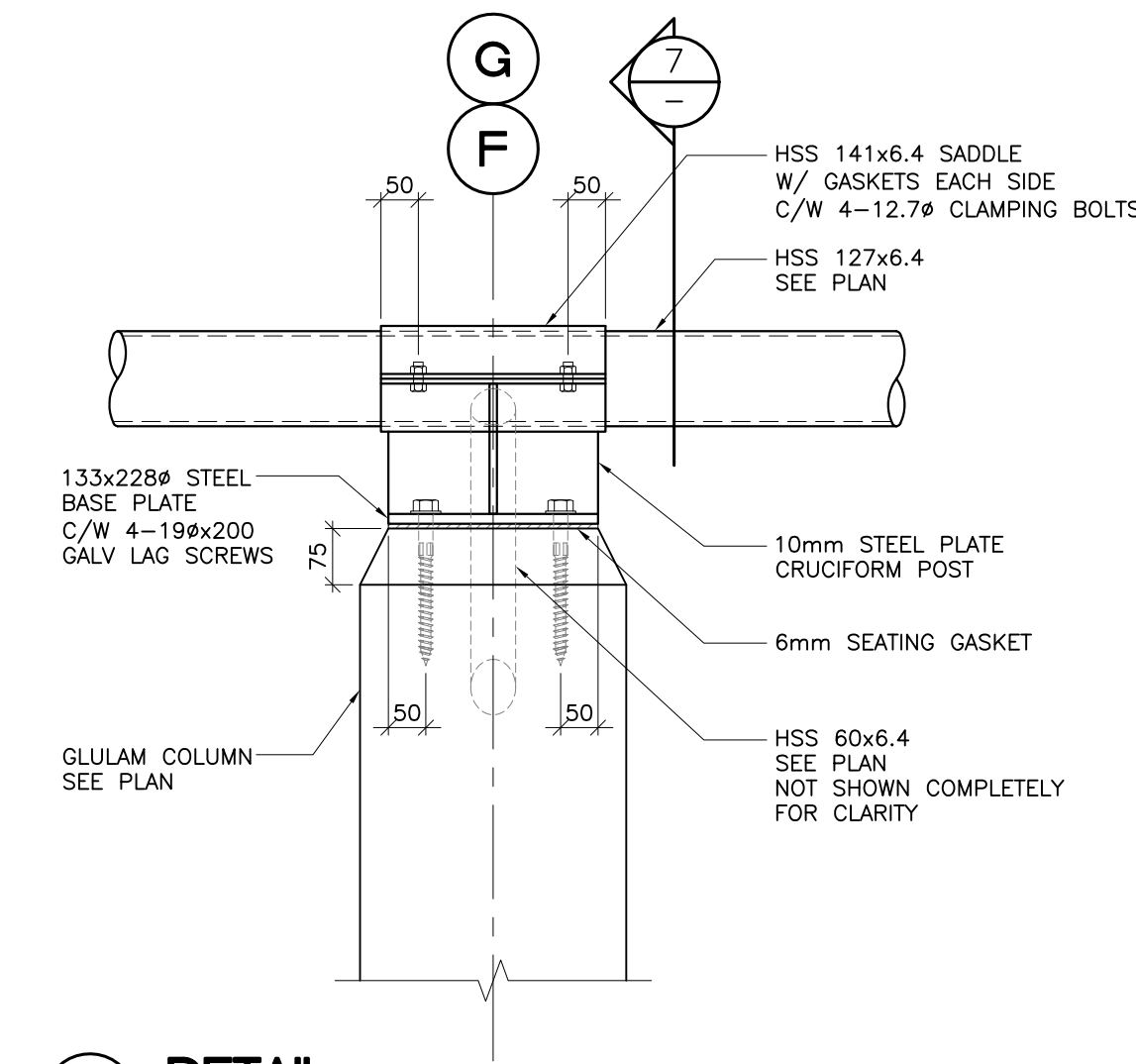
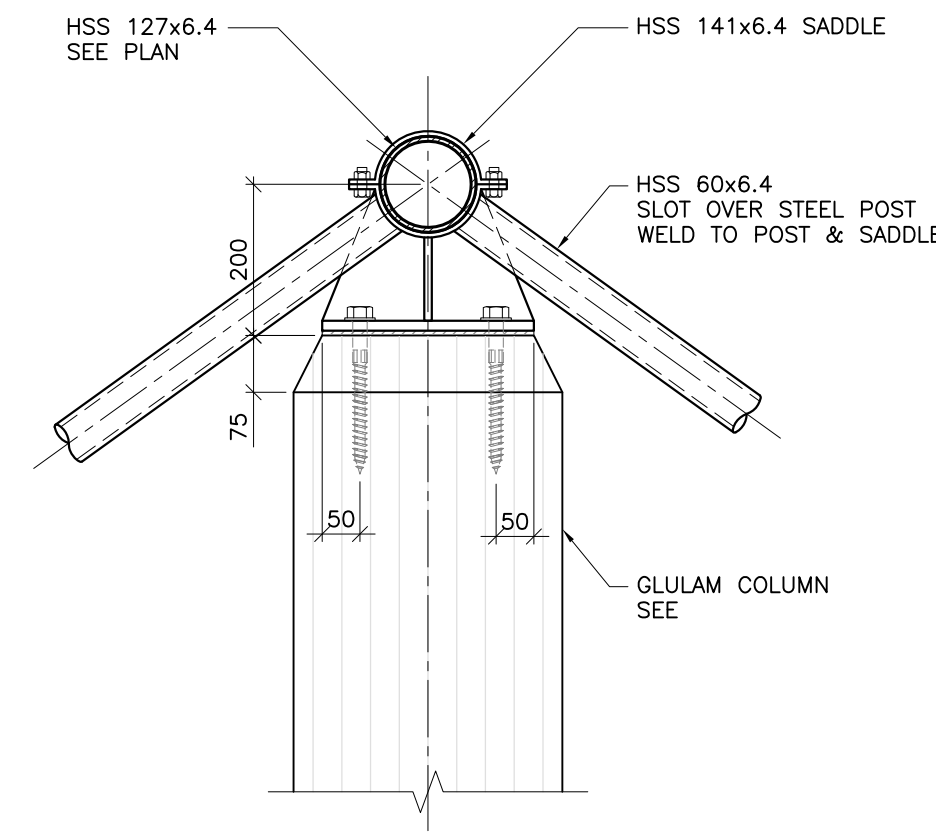
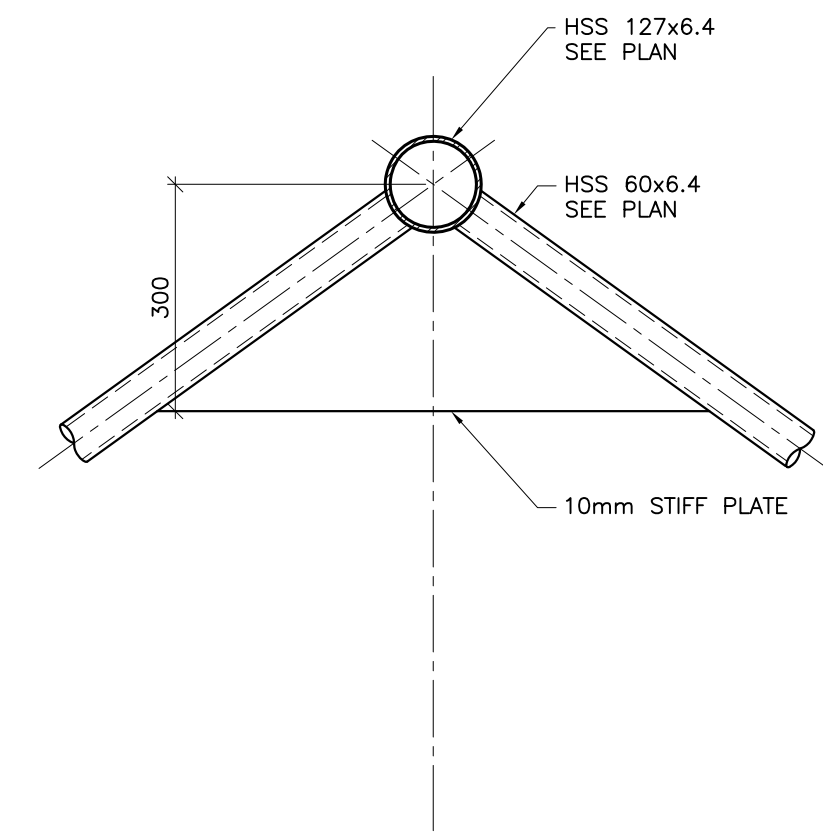

- IMPORTANT NOTES:**
1. REMOVE EXIST BEAMS ON GRIDS F & G AND EXISTING DECKING AND JOISTS BETWEEN GRIDS E-H/1-2. HAND OVER ALL REMOVED BEAMS AND DECKING TO OWNER.
 2. ALL STEEL PARTS TO BE HOT DIPPED GALVANIZED, TYP.
 3. ALL TIMBER AND GLULAM TO BE PRESSURE TREATED.
 4. ALL DIMENSIONS AND ELEVATIONS TO BE CONFIRMED ON SITE.
 5. ALL EXPOSED WELDS & FIELD WELDING TO BE GROUND SMOOTH.

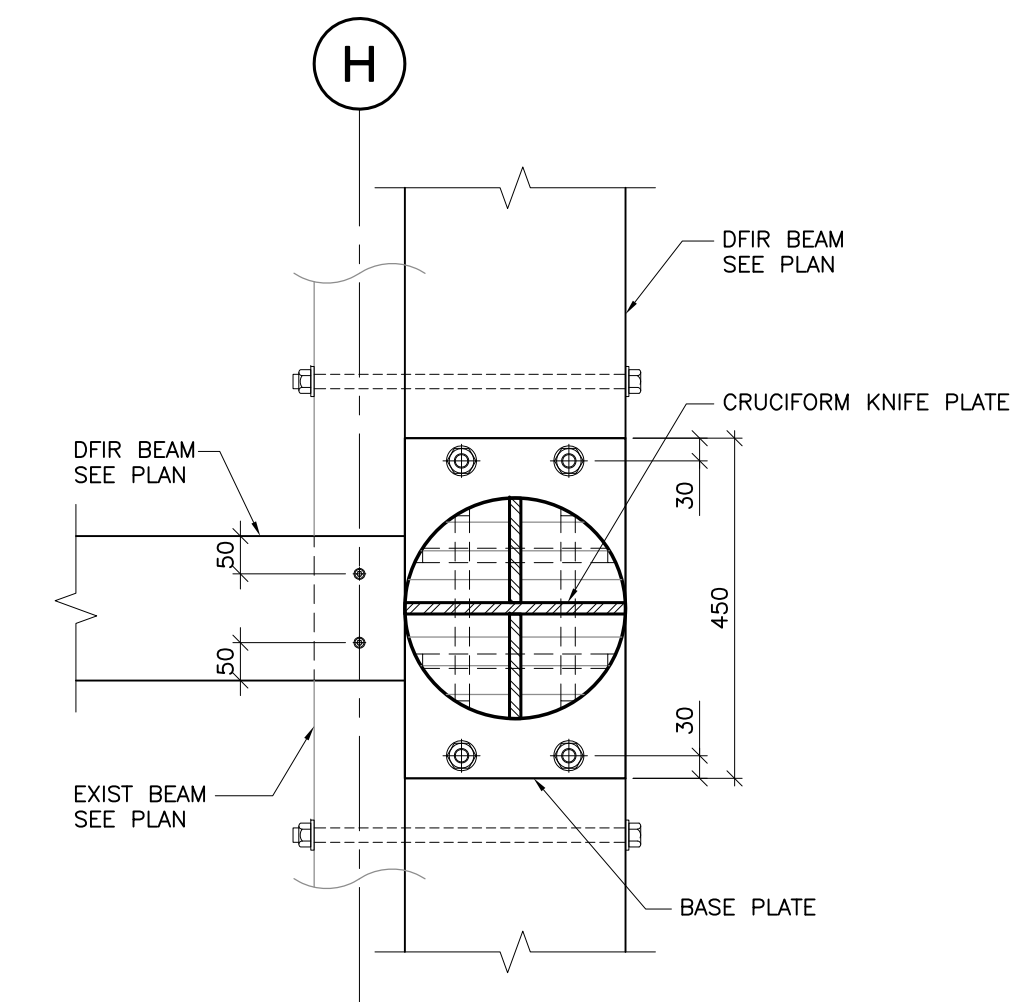
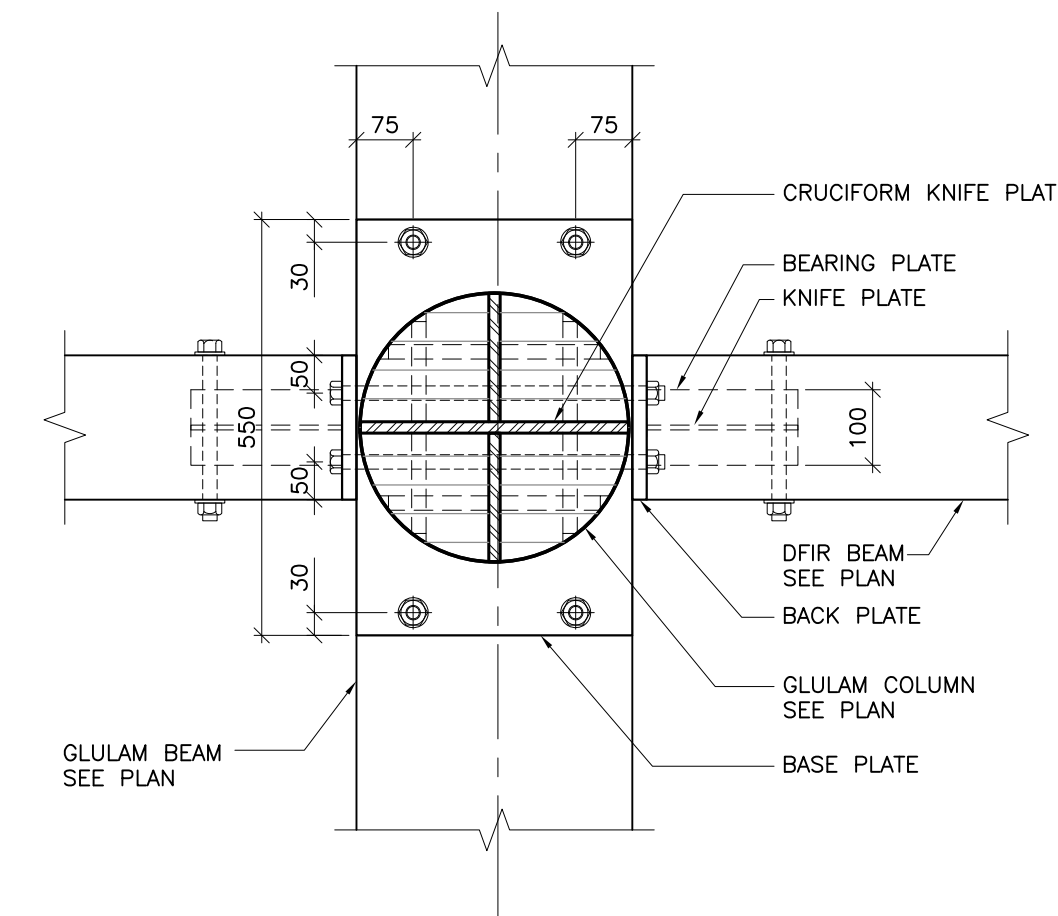
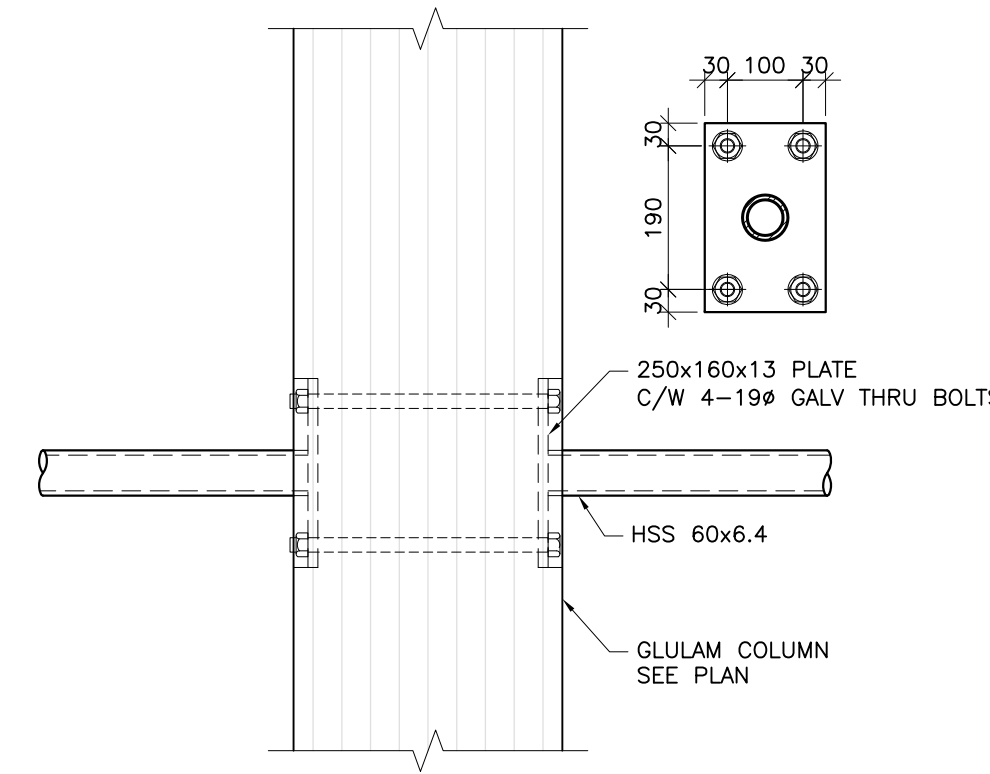
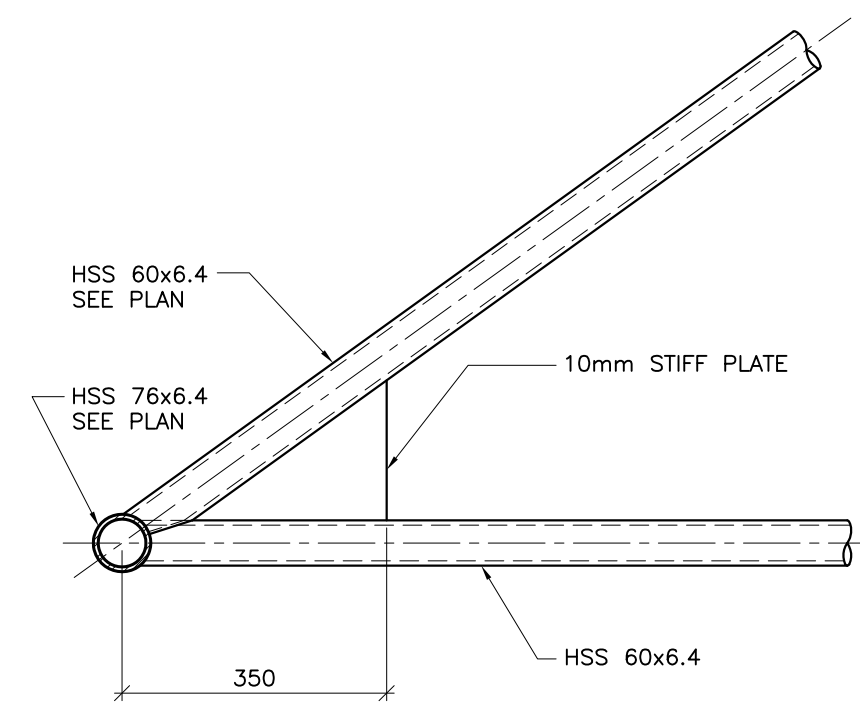

DETAIL 5
S05 1:10

DETAIL 4
S05 1:10

PLAN VIEW 2A
S05 1:10

PLAN VIEW 1A
S05 1:10

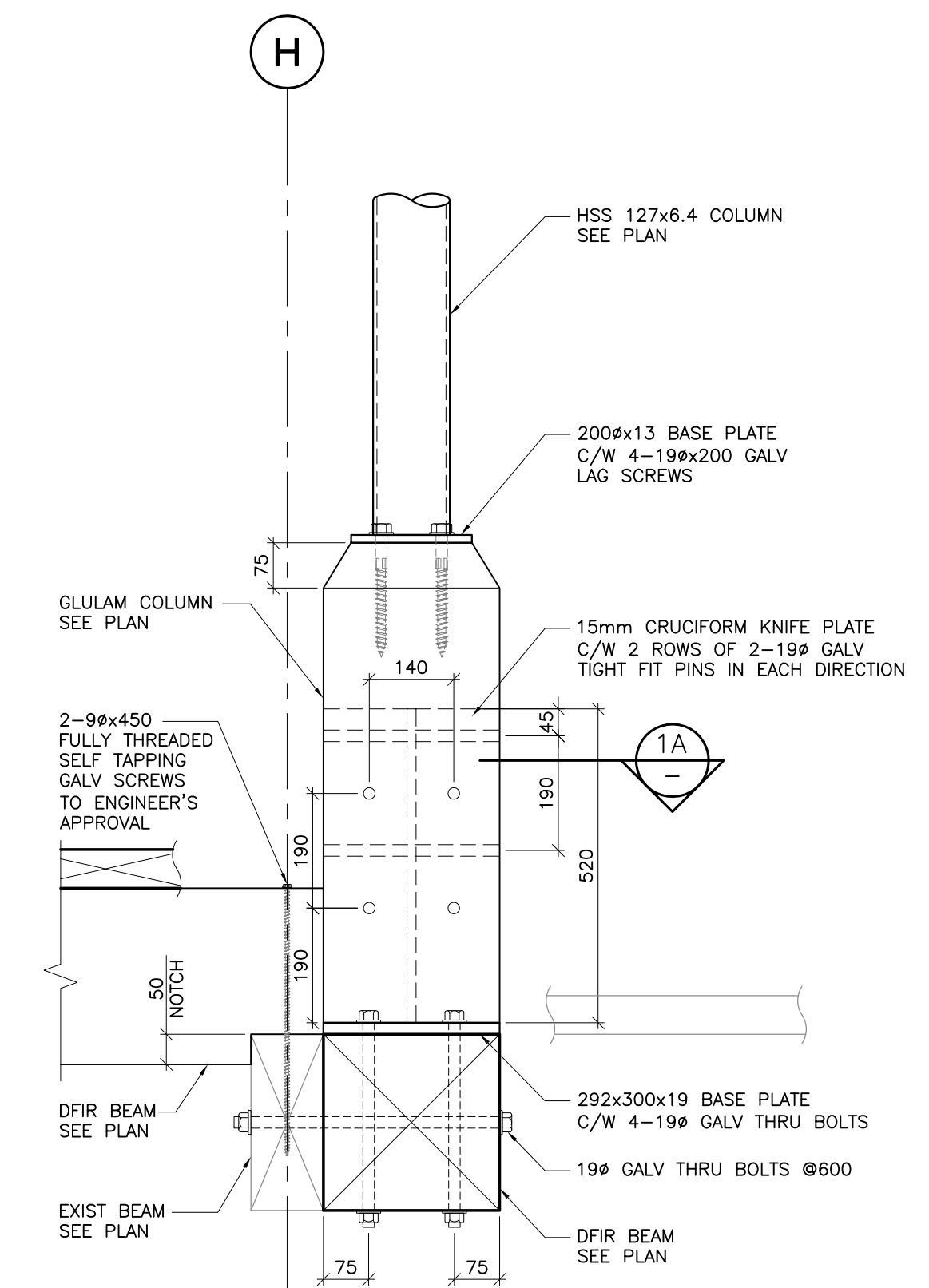
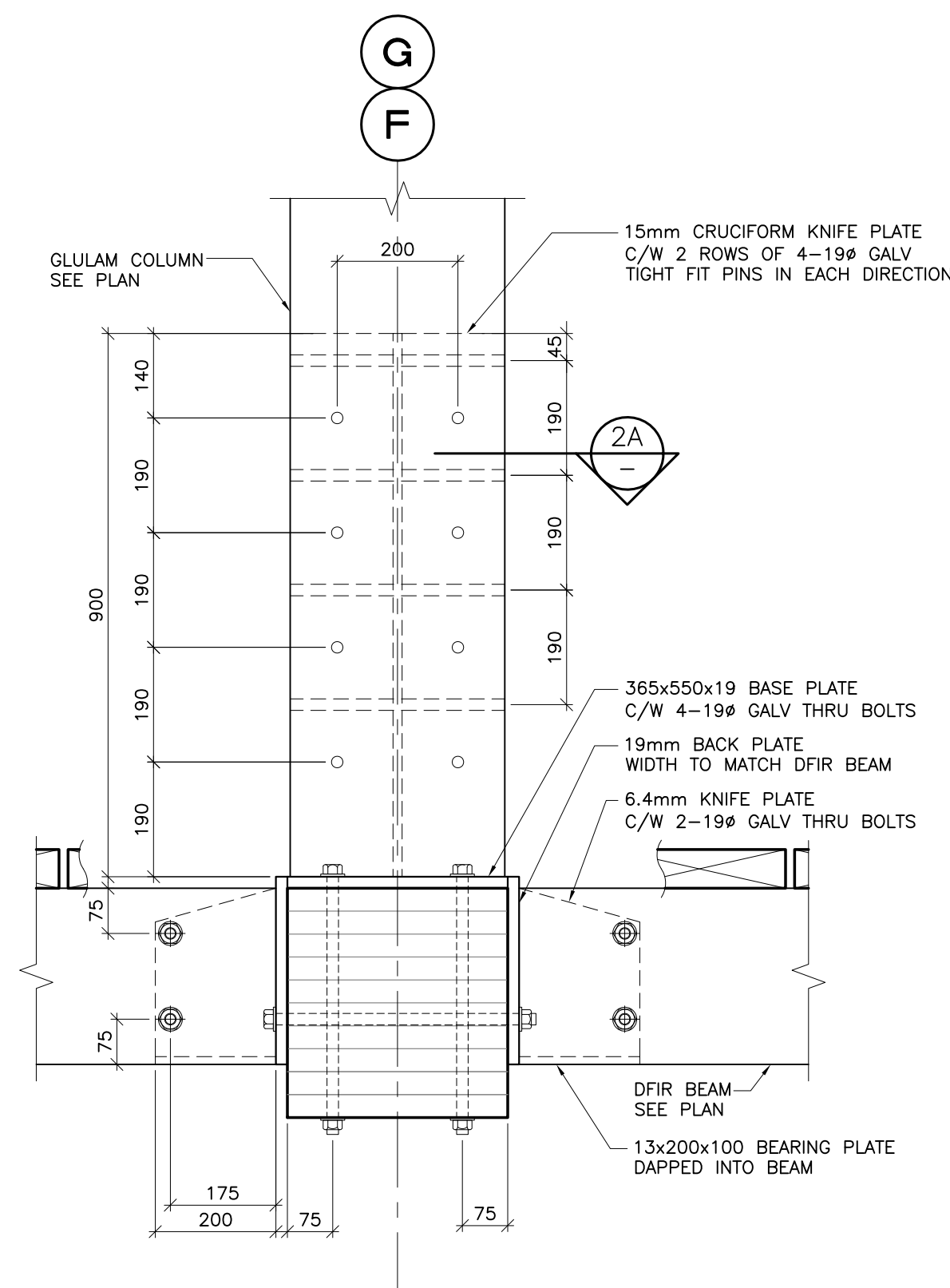
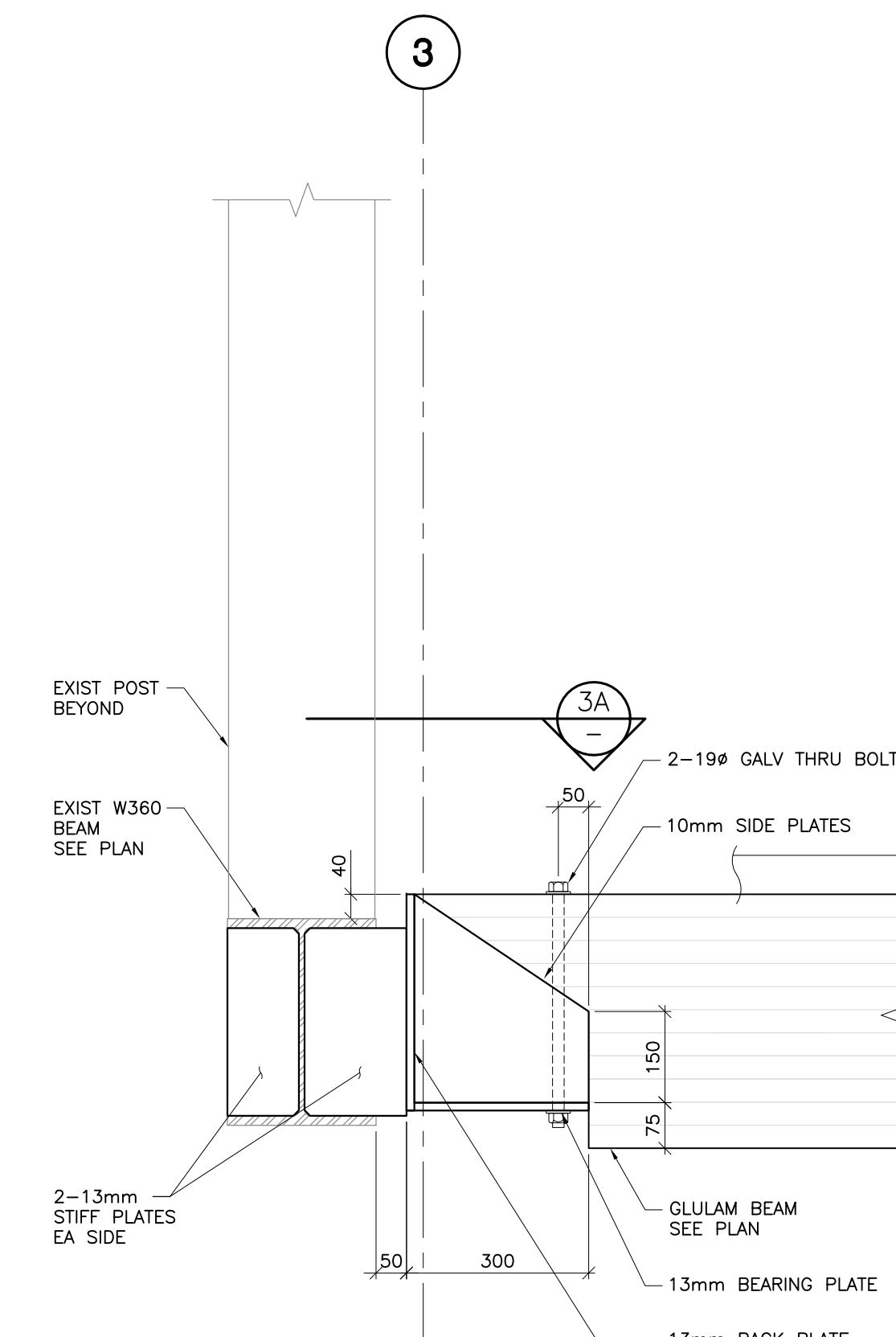
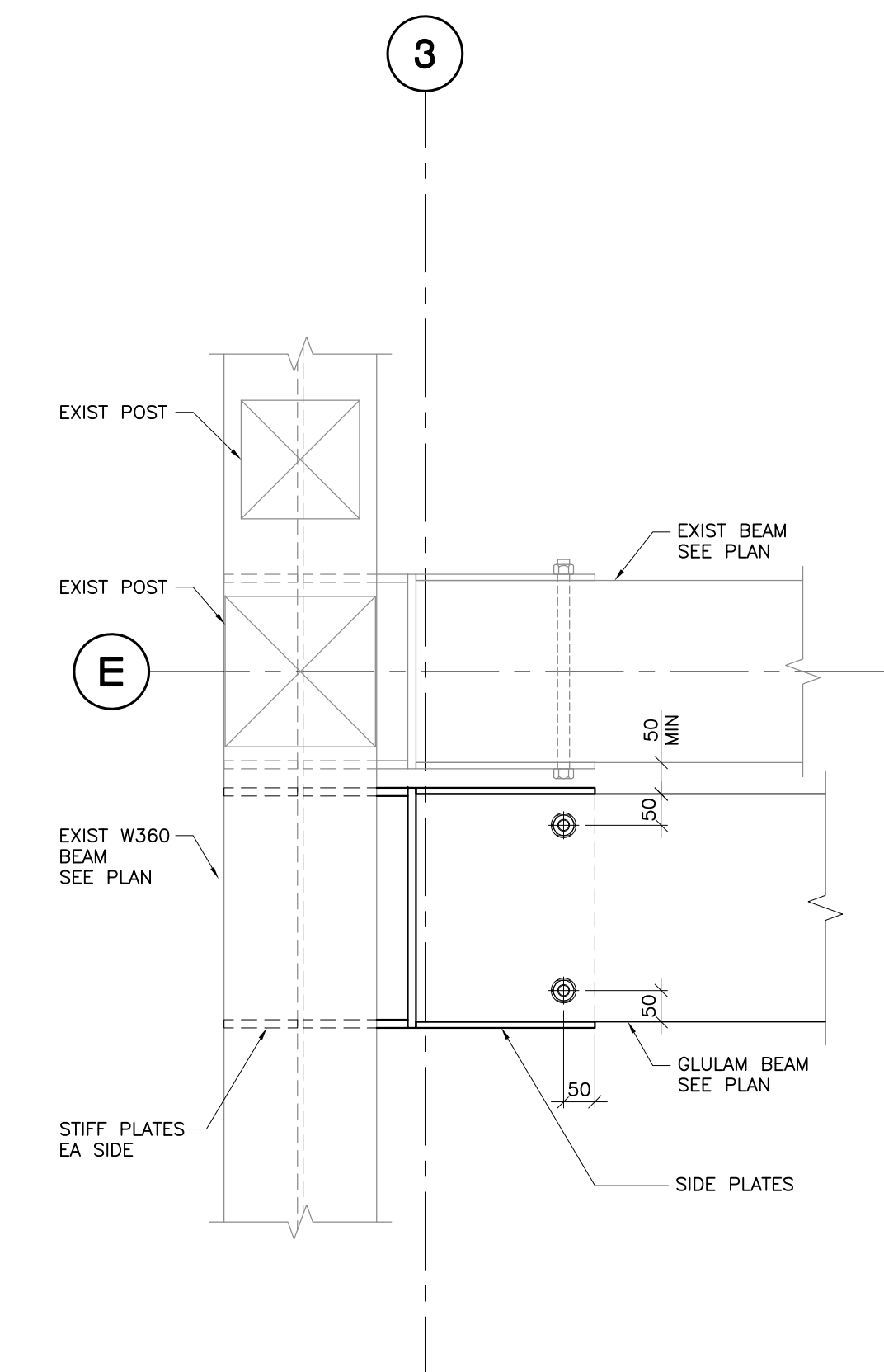

Project

PUBLIC MARKET PATIO
GRANVILLE ISLAND
VANCOUVER, BC

19/04/13 ISSUED FOR TENDER
Rev. DY/MT/YR Issued

Drawing Title

SECTIONS AND DETAILS

Date MAY 2012
Scale AS NOTED
Drawn By GS/RV
Checked By RM/DR

Project No. Drawing No.

11003 S04