



BELT, DUTY, LEATHER

G.S.1045-259A

Stud, Round Head, Rivet

Dwg. 2

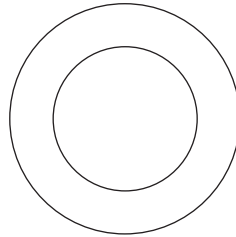

Top View

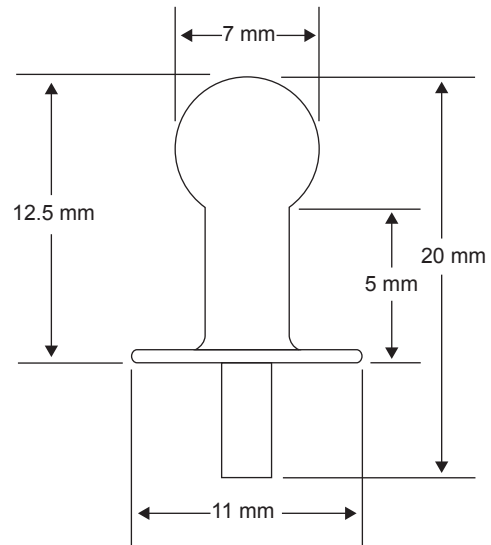

Side View

Tolerance of +0.5 mm unless otherwise stated.

Dwg. 2

NOT TO SCALE

Hook

Dwg. 3

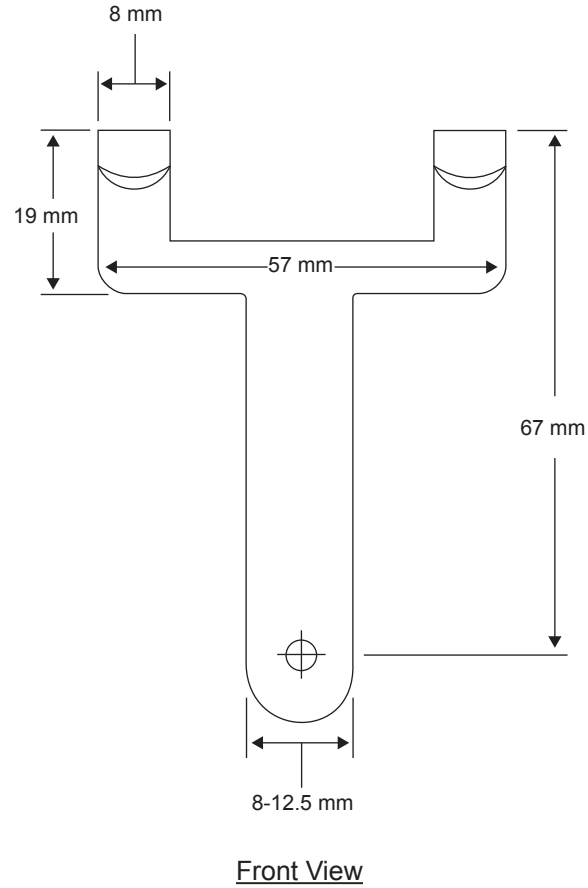
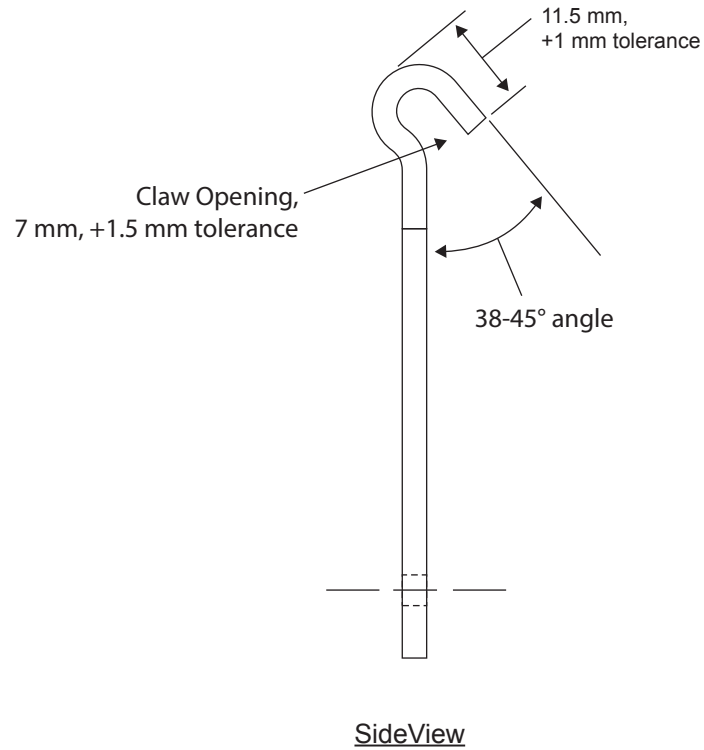

Material: Mild Steel 14 gauge  
Finish: Black Anodize and/or surface hardened  
Scale: Not to scale

Note: One piece construction; remove all burrs

Tolerance of +0.5mm unless otherwise stated. Claw opening MUST function correctly with double prong buckle regardless of the dimensions offered in this specification.

Dwg. 3

NOT TO SCALE

Double Prong Buckle

Dwg. 4

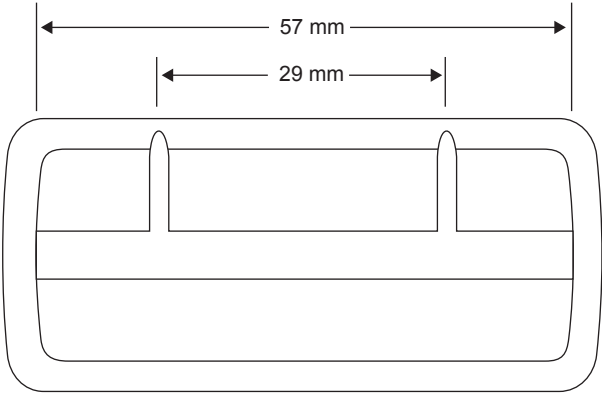

Front View

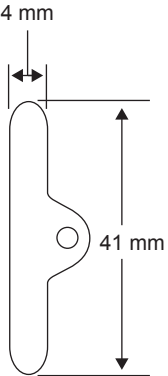

SideView

Tolerance of +0.5 mm unless otherwise stated.

Dwg. 4

NOT TO SCALE