



Public Works and Government Services Canada

Requisition No: EZ899-141867/A

DRAWINGS & SPECIFICATIONS
For:

Agassiz BC Kent Institution

GUN PORTS
for POD 1 & Principal Entrance

Project # R.066998.001

APPROVED BY:



Regional Manager, AES

2013-11-26
Date



Construction Safety Coordinator

2013-11-21
Date

TENDER:

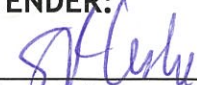

Project Manager

2013-11-26
Date

SPECIFICATION

SECTION	Number of Pages
Division 1 GENERAL REQUIREMENTS	
01 01 50 General Instructions	9
01 14 10 Security Requirements	7
01 35 33 Health and Safety Requirements	8
Division 2 to Division 7 N/A	
Division 8 Openings	
08 80 50 Glazing	3
Division 9 Finishes	
09 91 23 Paint	2
Division 10 N/A	
Division 11 Equipment	
11 19 60 Detention Fabrication	3
Division 12 to Division 33 N/A	
Appendix 1 Gun Port Reference Drawings	2

LIST OF DRAWINGS**Bound Separately**

A0	Title Sheet Location Plan
A1	Existing Main Floor Plan POD1
A2	Partial Main Floor Plan POD1 Demolition Elevations Details
A3	Partial Main Floor Plan POD1 Elevations Details
A4	Existing Main Floor Plan Principal Entrance Elevations Details

END OF INDEX

1 SUMMARY OF WORK

- .1 Work covered by Contract Documents:
 - .1 Work under this Contract comprises of the replacement of some existing glazing units with glazing units incorporating gun ports (provided by Departmental Representative) at the Control Posts of POD1 and the Principal Entrance at Kent Institution, Agassiz BC. Contract also includes removal and disposal of existing glazing units as noted and remedial work as required where affected by modifications.
- .2 Occupancy:
 - .1 The Institution and Control Posts will be operational during entire construction period.
 - .2 Co-operate with Departmental Representative in scheduling operations to minimize conflict and to facilitate CSC usage of premises.
- .3 Contractor's Use of Premises:
 - .1 Contractor has limited use of Control Posts and must phase work as instructed by Departmental Representative to suit operational requirements.
 - .2 Contractor has use of immediate construction areas for performance of Work and limited storage space for materials.
 - .3 Obtain and pay for use of additional storage or work areas needed for operations under this Contract.
 - .4 Vehicular access through the Sally Port will be restricted during the inmate "count" at breakfast, lunch and dinner hours. Confirm times with Departmental Representative. Delays may occur when entering and exiting the Institution with vehicles due to security situations and heavy traffic.
- .4 Contractor Responsibilities:
 - .1 Contractor to remove debris off-site daily.
 - .2 Review shop drawings and manufacturer's instructions. Submit to Departmental Representative notification of observed discrepancies or problems anticipated due to site conditions and/or non-conformance with Contract Documents.
 - .3 Provide and install glazing units & gun ports as per drawings.
 - .4 Handle products at site, including uncrating and temporary daily storage.
 - .5 Protect products from damage, and from exposure to elements.
 - .6 Assemble, install, connect, adjust, and finish products.
 - .7 Repair items damaged by Contractor on site (under his control).
- .5 Departmental Representative Responsibilities:
 - .1 Departmental Representative to provide gun ports.

2 WORK RESTRICTIONS

- .1 Notify, Departmental Representative of intended interruption of power and other services and provide schedule of interruption times.
 - .2 Security Requirements: refer to Section 01 14 10 - Security Requirements.
 - .3 Hours of work:
 - .1 Perform work 22:00 to 06:00, Monday through Friday except holidays, except as
-

GUN PORTS
for POD 1 & Principal Entrance

noted in Construction Work Schedule .

.2 Work may be performed on weekends and holidays. 7 days of notification to the Departmental Representative are required.

.3 Notify Departmental Representative forty-eight hours in advance of when after hours work will be required.

.4 Provide schedule for prior approval of Departmental Representative.

3 CONSTRUCTION WORK SCHEDULE

.1 Commence work immediately upon official notification of acceptance of offer and complete the work within eight (8) weeks from the date of such notification.

.2 Ensure that it is understood that Award of Contract or time of beginning, rate of progress, Substantial Certificate and Final Certificate as defined times of completion are of essence of this contract.

.3 Submittal:

.1 Submit to Departmental Representative within ten (10) working days of Award of Contract schedule of work.

.2 Departmental Representative will review schedule and return one copy.

.3 Re-submit two (2) copies of finalized schedule to Departmental Representative after return of reviewed preliminary copy.

.4 Project Meetings:

.1 Progress meetings to be bi-weekly.

4 SUBMITTAL PROCEDURES

.1 Administrative:

.1 Submit to Departmental Representative submittal listed for review. Submit with reasonable promptness and in orderly sequence so as to not cause delay in Work. Failure to submit in ample time is not considered sufficient reason for an extension of Contract Time and no claim for extension by reason of such default will be allowed.

.2 Work affected by submittal shall not proceed until review is complete.

.3 Present shop drawings, product data, samples and mock-ups in SI Metric units.

.4 Where items or information is not produced in SI Metric units converted values are acceptable.

.5 Review submittal prior to submission to Departmental Representative . This review represents that necessary requirements have been determined and verified, or will be, and that each submittal has been checked and co-ordinated with requirements of Work and Contract Documents. Submittal not stamped, signed, dated and identified as to specific project will be returned without being examined and shall be considered rejected.

.6 Notify Departmental Representative, in writing at time of submission, identifying deviations from requirements of Contract Documents stating reasons for deviations.

.7 Verify field measurements and affected adjacent Work are coordinated.

.8 Contractor's responsibility for errors and omissions in submission is not relieved by Departmental Representative review of submittal.

.9 Keep one reviewed copy of each submission on site.

5 HEALTH AND SAFETY

Specified in Section 01 35 33.

6 ENVIRONMENTAL PROCEDURES

- .1 Do not dispose of waste or volatile materials such as oil, paint thinner or mineral spirits into storm or sanitary systems.
- .2 Under no circumstances dispose of rubbish or waste materials in CSC waste bins or on adjoining property.

7 REGULATORY REQUIREMENTS

- .1 References and Codes:
 - .1 Perform Work in accordance with National Building Code of Canada (NBCC2010) and where applicable British Columbia Building Code (BCBC2006) including all amendments up to bid closing date and other codes of provincial or local application provided that in case of conflict or discrepancy, more stringent requirements apply.
 - .2 Meet or exceed requirements of:
 - .1 Contract documents.
 - .2 Specified standards, codes and referenced documents.

8 QUALITY CONTROL

- .1 Inspection:
 - .1 Give timely notice requesting inspection if Work is designated for special tests, inspections or approvals by Departmental Representative instructions, or law of Place of Work.
 - .2 If Contractor covers or permits to be covered Work that has been designated for special tests, inspections or approvals before such is made, uncover such Work, have inspections or tests satisfactorily completed and make good such Work.
 - .3 Departmental Representative may order any part of Work to be examined if Work is suspected to be not in accordance with Contract Documents. If, upon examination such work is found not in accordance with Contract Documents, correct such Work and pay cost of examination and correction. If such Work is found in accordance with Contract Documents, Departmental Representative shall pay cost of examination and replacement.
- .2 Rejected Work:
 - .1 Remove defective Work, whether result of poor workmanship, use of defective products or damage and whether incorporated in Work or not, which has been rejected by Departmental Representative as failing to conform to Contract Documents. Replace or re-execute in accordance with Contract Documents.
 - .2 Make good other Contractor's work damaged by such removals or replacements promptly.
- .3 Equipment and Systems:
 - .1 Install glazing units in accordance with manufacturer's instructions.

GUN PORTS
for POD 1 & Principal Entrance

9 TEMPORARY UTILITIES

- .1 Temporary Ventilation:
 - .1 The existing air system will be in use during work of this contract inside existing building. During dust/fume generating construction work block off all outlets and seal air tight.
 - .2 Provide adequate ventilation to meet health regulations for safe working environment.
- .2 Ventilating:
 - .1 Prevent accumulations of dust, fumes, mists, vapours or gases in areas occupied during construction.
 - .2 Provide local exhaust ventilation to prevent harmful accumulation of hazardous substances into atmosphere of occupied areas.
 - .3 Dispose of exhaust materials in manner that will not result in harmful exposure to persons.
- .3 Temporary Power and Light:
 - .1 Electrical power and lighting in existence in work area may be used for construction purposes at no extra cost, provided that electrical components used for temporary power are replaced when damaged.
 - .2 Conform to Section 01 35 33 Safety Requirements for use of existing power systems

10 CONSTRUCTION FACILITIES

- .1 Installation and Removal:
 - .1 Provide construction facilities in order to execute work expeditiously.
 - .2 Remove from site all such work after use.
 - .2 Site Storage/Loading:
 - .1 Confine work and operations of employees by Contract Documents. Do not unreasonably encumber premises with products.
 - .2 Do not load or permit to load any part of Work with a weight or force that will endanger the Work.
 - .3 Construction Parking:
 - .1 Park personnel vehicles outside perimeter fence in designated parking areas.
 - .4 Contractor's Site Office and enclosure:
 - .1 Locate office outside Institution double fence as directed by the Departmental Representative.
 - .5 Equipment, Tools and Material Storage:
 - .1 Provide and maintain, in a clean and orderly condition, lockable bins for storage of tools, and equipment.
 - .2 Locate materials in a manner to cause least interference with work activities.
 - .6 Sanitary Facilities:
 - .1 Existing washroom facilities may be used during the construction period as designated by Departmental Representative .
-

GUN PORTS
for POD 1 & Principal Entrance

- .7 Construction Signs:
 - .1 Signs and notices for safety or instruction to be in English language, or commonly understood graphic symbols.
 - .2 Remove signs from site at completion of project or as directed by Departmental Representative.

11 TEMPORARY BARRIERS AND ENCLOSURES

- .1 Protection of openings:
 - .1 Provide secure protection for openings during construction to maintain security.
- .2 Protection for Off-Site and CSC Property:
 - .1 Protect surrounding CSC property from damage during performance of Work.
 - .2 Be responsible for damage incurred.
- .3 Protection of Building Finishes:
 - .1 Provide protection for building finishes and equipment during performance of Work.
 - .2 Provide necessary screens, covers, and hordings.
 - .3 Confirm with Departmental Representative locations and installation schedule 3 days prior to installation.
 - .4 Be responsible for damage incurred due to lack of or improper protection.

12 COMMON PRODUCT REQUIREMENTS

- .1 Reference Standards:
 - .1 If there is a question as to whether any product or system is in conformance with applicable standards, Departmental Representative reserves right to have such products or systems tested to prove or disprove conformance.
 - .2 Cost for such testing will be born by Departmental Representative in event of conformance with Contract Documents or by Contractor in event of non-conformance.
 - .3 Conform to latest date of issue of referenced standards in effect on date of submission of Bids, except where specific date or issue is specifically noted.
 - .2 Quality:
 - .1 Products, materials, equipment and articles (referred to as products throughout specifications) incorporated in Work shall be new, not damaged or defective, and of best quality (compatible with specifications) for purpose intended. If requested, furnish evidence as to type, source and quality of products provided.
 - .2 Defective products, whenever identified prior to completion of Work, will be rejected, regardless of previous inspections. Inspection does not relieve responsibility, but is precaution against oversight or error. Remove and replace defective products at own expense and be responsible for delays and expenses caused by rejection.
 - .3 Should any dispute arise as to quality or fitness of products, decision rests strictly with Departmental Representative based upon requirements of Contract Documents.
 - .3 Storage, Handling and Protection:
 - .1 Handle and store products in manner to prevent damage, adulteration, deterioration and soiling and in accordance with manufacturer's instructions when applicable.
 - .2 Store packaged or bundled products in original and undamaged condition with manufacturer's seal and labels intact. Do not remove from packaging or bundling until
-

GUN PORTS
for POD 1 & Principal Entrance

required in Work.

.3 Store products subject to damage from weather in weatherproof enclosures.

.4 Store and mix paints in heated and ventilated room. Remove oily rags and other combustible debris from site daily. Take every precaution necessary to prevent spontaneous combustion.

.5 Remove and replace damaged products at own expense and to satisfaction of Departmental Representative .

.4 Transportation:

.1 Pay costs of transportation of products required in performance of Work.

.2 Products supplied by Departmental Representative are located on site at Kent Institution.

.5 Manufacturer's Instructions:

.1 Unless otherwise indicated in specifications, install or erect products in accordance with manufacturer's instructions. Do not rely on labels or enclosures provided with products.

.2 Notify Departmental Representative in writing, of conflicts between specifications and manufacturer's instructions, so that Departmental Representative may establish course of action.

.6 Quality of Work:

.1 Ensure Quality of Work is of highest standard, executed by workers experienced and skilled in respective duties for which they are employed. Immediately notify Departmental Representative if required Work is such as to make it impractical to produce required results.

.2 Do not employ anyone unskilled in their required duties. Departmental Representative reserves right to require dismissal from site, workers deemed incompetent or careless.

.3 Decisions as to standard or fitness of Quality of Work in cases of dispute rest solely with Departmental Representative, whose decision is final.

.7 Co-ordination:

.1 Ensure cooperation of workers in laying out Work. Maintain efficient and continuous supervision.

.2 Be responsible for coordination and placement of openings, and accessories.

.8 Remedial Work:

.1 Perform remedial work required to repair or replace parts or portions of Work identified as defective or unacceptable. Coordinate adjacent affected Work as required.

.2 Perform remedial work by specialists familiar with materials affected. Perform in a manner to neither damage nor put at risk any portion of Work.

.9 Fastenings:

.1 Provide metal fastenings and accessories in same texture, colour and finish as adjacent materials, unless indicated otherwise.

.2 Prevent electrolytic action between dissimilar metals and materials.

.3 Use non-corrosive hot dip galvanized steel fasteners and anchors for securing work, unless stainless steel or other material is specifically requested in affected specification Section.

.10 Substitution after award of Contract:

.1 No substitutions are permitted without prior written approval of the Departmental

Representative.

- .2 Proposals for substitution may only be submitted after Contract award. Such request must include statements of respective costs of items originally specified and the proposed substitution.
- .3 Proposals will be considered by the Departmental Representative if:
 - .1 Products selected by tenderer from those specified are not available;
 - .2 delivery date of products selected from those specified would unduly delay completion of Contract, or
- .4 Alternative product to that specified, which is brought to the attention of and considered by Departmental Representative as equivalent to the product specified, and will result in a credit to the Contract amount.
- .5 Should the proposed substitution be accepted either in part or in whole, assume full responsibility and costs when substitution affects other work on the project. Pay for design or drawing changes required as result of substitution.
- .6 Amounts of all credits arising from approval of the substitutions will be determined by the Departmental Representative, and the Contract price will be reduced accordingly.

13 EXECUTION REQUIREMENTS

- .1 Preparation:
 - .1 Inspect existing conditions, including elements subject to damage or movement during drilling and patching.
 - .2 After uncovering, inspect conditions affecting performance of Work.
 - .3 Beginning of drilling or patching means acceptance of existing conditions.
 - .4 Provide devices and methods to protect adjacent surfaces from damage.
- .2 Execution:
 - .1 Execute drilling, fitting, and patching to complete Work.
 - .2 Fit several parts together, to integrate with other Work.
 - .3 Uncover Work to install ill-timed Work.
 - .4 Remove and replace defective and non-conforming Work.
 - .5 Execute Work by methods to avoid damage to other Work, and which will provide proper surfaces to receive patching and finishing.
 - .6 Cut rigid materials using purpose made saw or core drill. Pneumatic or impact tools not allowed on brittle materials without prior approval.
 - .7 Restore work with new products in accordance with requirements of Contract Documents.
 - .8 Fit Work airtight to penetrations through surfaces.
 - .9 Refinish surfaces to match adjacent finishes: For continuous surfaces refinish to nearest intersection; for an assembly, refinish entire unit.

14 CLEANING

- .1 Project Cleanliness:
 - .1 Maintain Work in tidy condition, free from accumulation of waste products and debris. Remove on a regular basis at the end of each daily work shift.
 - .2 Remove waste materials from site at regularly scheduled times or dispose of as directed by Departmental Representative. Do not burn waste materials on site, unless approved by Departmental Representative.
 - .3 Provide on-site containers for collection of waste materials and debris.
-

GUN PORTS
for POD 1 & Principal Entrance

- .4 Provide and use clearly marked separate bins for recycling. Refer to- Construction/Demolition Waste Management And Disposal.
- .5 Clean interior areas prior to start of finish work, and maintain areas free of dust and other contaminants during finishing operations.
- .6 Store volatile waste in covered metal containers, and remove from premises at end of each working day.
- .7 Provide adequate ventilation during use of volatile or noxious substances. Use of building ventilation systems is not permitted for this purpose.
- .8 Use only cleaning materials recommended by manufacturer of surface to be cleaned, and as recommended by cleaning material manufacturer.
- .9 Schedule cleaning operations so that resulting dust, debris and other contaminants will not fall on wet, newly painted surfaces nor contaminate building systems.

.2 Final Cleaning:

- .1 When Work is Substantially Performed, remove surplus products, tools, construction machinery and equipment not required for performance of remaining Work.
- .2 Remove waste products and debris other than that caused by others, and leave Work clean and suitable for occupancy.
- .3 Prior to final review, remove surplus products, tools, and equipment.
- .4 Remove waste products.
- .5 Clean glass, gun ports and adjacent surfaces affected by renovation work.
- .6 Remove stains, spots, marks and dirt from adjacent surfaces, walls and floors.
- .7 Vacuum clean and dust building interior at work areas.

15 CONSTRUCTION/DEMOLITION WASTE MANAGEMENT AND DISPOSAL

- .1 Provide on-site facilities for collection, handling, and storage of anticipated quantities of reusable and/or recyclable materials and waste.
 - .1 Separate non-salvageable materials from salvaged items.
 - .2 Handle waste materials not reused, salvaged, or recycled in accordance with appropriate regulations and codes.
 - .3 Transport and deliver non-salvageable items to licensed disposal facility.
- .2 Provide containers to deposit reusable and/or recyclable materials. Locate containers in locations, to facilitate deposit of materials without hindering daily operations. Provide containers to deposit reusable and/or recyclable materials.
- .3 Collect, handle, store on-site and transport off-site, salvaged materials in separate condition. Transport to approved and authorized recycling facility and/or users of material for recycling.
- .4 Locate waste and salvage bins on site as directed by Departmental Representative.

16 CLOSEOUT PROCEDURES

- .1 Inspection and Declaration:
 - .1 Contractor's Inspection: Conduct an inspection of Work with all subcontractors, identify deficiencies and defects, and repair as required to conform to Contract Documents.
 - .2 Notify Departmental Representative in writing of satisfactory completion of Contractor's Inspection and that corrections have been made.
 - .3 Request Departmental Representative's Inspection.
-

GUN PORTS
for POD 1 & Principal Entrance

- .2 Inspection: Departmental Representative and Contractor will perform inspection of Work to identify obvious defects or deficiencies. Contractor shall correct Work accordingly.
- .3 Completion: submit written certificate that following have been performed:
 - .1 Work has been completed and inspected for compliance with Contract Documents.
 - .2 Defects have been corrected and deficiencies have been completed.
 - .3 Equipment and systems have been tested, adjusted and balanced and are fully operational.
 - .4 Work is complete and ready for Final Inspection.
- .4 Final Inspection: when items noted above are completed, request final inspection of Work by Departmental Representative. If Work is deemed incomplete by Departmental Representative, complete outstanding items and request reinspection.

17 CLOSEOUT SUBMITTAL

- .1 Record Drawings:
 - .1 As work progresses, maintain accurate records to show all deviations from the Contract Drawings. Note on as-built drawings in red as changes occur. At completion supply:
 - .1 One (1) set of marked up as-built drawings. One disk of As-built CADD drawings.
 - .2 Contractor may place on the upper right-hand title block area a small company logo, the text "AS-BUILT" and the date.

END OF SECTION

1 PURPOSE

- .1 To ensure that both the construction project and the institutional operations may proceed without undue disruption or hindrance and that the security of the Institution is maintained at all times.

2 DEFINITIONS

- .1 "Contraband" means:
- (a) an intoxicant, including alcoholic beverages, drugs and narcotics
 - (b) a weapon or a component thereof, ammunition for a weapon, and anything that is designed to kill, injure or disable a person or that is altered so as to be capable of killing, injuring or disabling a person, when possessed without prior authorization,
 - (c) an explosive or a bomb or a component thereof,
 - (d) currency over any applicable prescribed limit, \$25.00, and
 - (e) any item not described in paragraphs (a) to (d) that could jeopardize the security of a Penitentiary or the safety of persons, when that item is possessed without prior authorization.
- .2 "Unauthorized smoking and related items" means all smoking items including, but not limited to, cigarettes, cigars, tobacco, chewing tobacco, cigarette making machines, matches and lighters.
- .3 "Commercial Vehicle" means any motor vehicle used for the shipment of material, equipment and tools required for the construction project.
- .4 "CSC" means Correctional Service Canada.
- .5 "Director" means Director or Warden of the Institution as applicable or their representative.
- .6 "Construction employees" means persons working for the general contractor, the sub-contractors, equipment operators, material suppliers, testing and inspection companies and regulatory agencies. Workers 18 years or younger are not permitted within Institution.
- .7 "Departmental Representative" means the Public Works and Government Services Canada representative defined in General Conditions.
- .8 "Perimeter" means the fenced or walled area of the institution that restrains the movement of the inmates.
- .9 "Construction zone" means the area, as indicated in the contract documents, that the contractor will be allowed to work". This area may or may not be isolated from the security area of the Institution. Limits to be confirmed at construction start-up meeting.
- .1 Construction zone for this contract includes the project location at Kent Institution - POD1 Control Post & Principal Entrance Control Post.

3 PRELIMINARY PROCEEDINGS

- .1 At construction start-up meeting:
- .1 Discuss the nature and extent of all activities involved in the Project.
 - .2 Establish mutually acceptable security procedures in accordance with this instruction and the Institution's particular requirements.
- .2 The contractors's responsibilities:
- .1 Ensure that all construction employees are aware of the CSC security requirements.
 - .2 Ensure that a copy of the CSC security requirements is always prominently on display at the job site.
 - .3 Co-operate with institutional personnel in ensuring that security requirements are observed by all construction employees.

4 CONSTRUCTION EMPLOYEES

- .1 Submit to the Departmental Representative a list of the names with date of birth of all construction employees to be employed on the construction site and a security clearance form for each employee.
- .2 Allow 10 working days for processing of security clearances. Employees will not be admitted to the Institution without a valid security clearance in place and a recent picture identification such as a provincial driver's license. Security clearances obtained from other CSC Institutions are not valid at this Institution except as approved otherwise.
- .3 The Director may require that facial photographs may be taken of construction employees and these photographs may be displayed at appropriate locations in the Institution or in an electronic database for identification purposes. The Director may require that Photo ID cards be provided for all construction workers. ID cards will then be left at the designated entrance to be picked upon arrival at the Institution and shall be displayed prominently on the construction employees clothing at all time while employees are at the Institution.
- .4 Entry to Institutional Property will be refused to any person if there is reason to believe that they may be a security risk.
- .5 Any person employed on the construction site will be subject to immediate removal from Institutional Property if they:
 - .1 appear to be under the influence of alcohol, drugs or narcotics.
 - .2 behave in an unusual or disorderly manner.
 - .3 are in possession of contraband.
 - .4 are 18 years old or younger.

5 VEHICLES

- .1 All unattended vehicles on CSC property must have windows closed; fuel caps locked, doors and trunks locked and keys removed. The keys must be securely in the possession of the owner or an employee of the company that owns the vehicle.
- .2 The director may limit at any time the number and type of vehicles allowed within the Institution.
- .3 Drivers of delivery vehicles for material required by the project will require security clearances and must remain with their vehicle the entire time that the vehicle is in the Institution. The director may require that these vehicles be escorted by Institutional staff or PWGSC Construction Escorts while in the Institution.
- .4 If the Director permits trailers to be left inside the secure perimeter of the Institution, the trailer doors must be locked at all times. All windows must be securely locked bars when left unoccupied. Cover all windows with expanded metal mesh. When not in use lock all storage trailers located inside and outside the perimeter. All storage trailers inside and outside the perimeter must be locked when not in use.

6 PARKING

- .1 The parking area(s) to be used by construction employees will be designated by the Director. Parking in other locations will be prohibited and vehicles may be subject to removal.
-

7 SHIPMENTS

- .1 To avoid confusion with the Institution's own shipments, address all shipments of project material, equipment and tools in the Contractor's name and have a representative on site to receive any deliveries or shipments. CSC or PWGSC staff will **NOT** accept receipt of deliveries or shipments of any material equipment or tools for the contractor.

8 TELEPHONES

- .1 The installation of telephones, facsimile machines and computers with Internet connections is not permitted within the Institution perimeter unless prior approved by the Director.
- .2 The Director will ensure that approved telephones, facsimile machine and computers with Internet connections are located where they are not accessible to inmates. All computers will have an approved password protection that will stop an Internet connection to unauthorized personnel.
- .3 Wireless cellular and digital telephones, including but not limited to devices for telephone messaging, pagers, Blackberries, PDAs, telephone used as 2-way radios are not permitted within the Institution unless approved by the Director. If wireless cellular telephones are permitted, the user will not permit their use by any inmate.
- .4 The Director may approve but limit the use of 2-way radios.

9 WORK HOURS

- .1 Work hours within the Institution are: conform to Division 1.
- .2 Work is not permitted during weekends and statutory holidays without the permission of the Director. A minimum of seven days advance notice will be required to obtain the required permission. In case of emergencies or other special circumstances, this advance notice may be waived by the Director.

10 OVERTIME WORK

- .1 Conform to Division 1.
- .2 Provide 48 hours advance notice to Director for all work to be performed after normal working hours of the Institution. Notify Director immediately if emergency work is required, such as to complete a concrete pour or make the construction site safe and secure.

11 TOOLS AND EQUIPMENT

- .1 Maintain a complete list of all tools and equipment to be used during the construction project. Make this inventory available for inspection when required by the Institution.
 - .2 Throughout the construction project maintain up-to-date the list of tools and equipment specified above.
 - .3 Keep all tools and equipment under constant supervision, particularly power-driven and cartridge-driven tools, cartridges, files, saw blades, rod saws, wire, rope, ladders and any sort of jacking device.
 - .4 Store all tools and equipment in approved secure locations.
 - .5 Lock all tool boxes when not in use. Keys to remain in the possession of the employees of the contractor. Secure and lock scaffolding when not erected and when erected Secure in a manner agreed upon with the Institution designate.
-

- .6 Report all missing or lost tools or equipment immediately to the Departmental Representative/Director.
- .7 The Director will ensure that the security staff members carry out checks of the Contractor's tools and equipment against the list provided by the Contractor. These checks may be carried out at the following intervals:
 - .1 At the beginning and conclusion of every work day or shift upon entering and exiting the Institution.
 - .2 At any time when contractor is on Institution property.
- .8 Certain tools/equipment such as cartridges and hacksaw blades are highly controlled items. The contractor will be given at the beginning of the day, a quantity that will permit one day's work. Used blades/cartridges will be returned to the Director's representative at the end of each day. Maintain up to date inventory of all used blades/cartridges.
- .9 If propane or natural gas is used for heating the construction, the Institution will require that the contractor supervise the construction site during non-working hours.

12 KEYS

- .1 Security Hardware Keys.
 - .1 Arrange with the security hardware supplier/installer to have the keys for the security hardware to be delivered directly to Institution, specifically the Security Maintenance Officer (SMO).
 - .2 The SMO will provide a receipt to the Contractor for security hardware keys.
 - .3 Provide a copy of the receipt to the Departmental Representative.
- .2 Other Keys
 - .1 Use standard construction cylinders for locks for his use during the construction period.
 - .2 Issue instructions to employees and sub-trades, as necessary, to ensure safe custody of the construction set of keys.
 - .3 Upon completion of each phase of the construction, the CSC representative will, in conjunction with the lock manufacturer:
 - .1 Prepare an operational keying schedule
 - .2 Accept the operational keys and cylinders directly from the lock manufacturer.
 - .3 Arrange for removal and return of the construction cores and install the operational core in all locks.
 - .4 Upon putting operational security keys into use, the PWGSC construction escort will obtain these keys as they are required from the SMO and open doors as required by the Contractor. The Contractor shall issue instructions to his employees advising them that all security keys shall always remain with the PWGSC construction escort.

13 SECURITY HARDWARE

- .1 Turn over all removed security hardware to the Director of the Institution for disposal or for safekeeping until required for re-installation.

14 PRESCRIPTION DRUGS

- .1 Employees of the contractor who are required to take prescription drugs during the workday shall obtain approval of the Director to bring a one day supply only into the Institution.
-

15 SMOKING RESTRICTIONS

- .1 Smoking is not permitted inside correctional facilities or outdoors within the perimeter of a correctional facility and persons must not possess unauthorized smoking items within the perimeter of a correctional facility.
- .2 Persons in violation of this policy will be requested to immediately cease smoking or dispose of any unauthorized smoking items and, if they persist will be directed to leave the Institution.
- .3 Smoking is permitted outside the perimeter of a correctional facility in an area designated by the Director.

16 CONTRABAND

- .1 Weapons, ammunition, explosives, alcoholic beverages, drugs and narcotics are prohibited on Institutional property.
- .2 The discovery of contraband on the construction site and the identification of the person(s) responsible for the contraband shall be reported immediately to the Director.
- .3 Contractors should be vigilant with both their staff and the staff of their sub-contractors and suppliers that the discovery of contraband may result in cancellation of the security clearance of the affected employee. Serious infractions may result in the removal of the company from the Institution for the duration of the construction.
- .4 Presence of arms and ammunition in vehicles of contractors, sub-contractors and suppliers or employees of these will result in the immediate cancellation of security clearances for the driver of the vehicle.

17 SEARCHES

- .1 All vehicles and persons entering Institutional property may be subject to search.
- .2 When the Director suspects, on reasonable grounds, that an employee of the Contractor is in possession of contraband, he may order that person to be searched.
- .3 All employees entering the Institution may be subject to screening of personal effects for traces of contraband drug residue.

18 ACCESS TO AND REMOVAL FROM INSTITUTIONAL PROPERTY

- .1 Construction personnel and commercial vehicles will not be admitted to the Institution after normal working hours, unless approved by the Director.

19 MOVEMENT OF VEHICLES

- .1 Construction vehicles are not to leave the Institution until an inmate count is completed. Escorted commercial vehicles will be allowed to enter or leave the Institution through the vehicle access gate during the following hours:
 - .1 AM: 0745 hrs. to 1100 hrs.
 - .2 PM: 1300hrs. to 1530 hrs.
- .2 The contractor will advise the Director twenty four (24) hours in advance to the arrival on the site of heavy equipment such as concrete trucks, cranes, etc.

- .3 Vehicles being loaded with soil or other debris, or any vehicle considered impossible to search, must be under continuous supervision by CSC staff or PWGSC construction escorts working under the authority of the Director.
- .4 Commercial vehicles will only be allowed access to institutional property when their contents are certified by the Contractor or his representative as being strictly necessary to the execution of the construction project.
- .5 Vehicles will be refused access to institutional property if, in the opinion of the Director, they contain any article which may jeopardize the security of the Institution. Arrange with Director for parking of contractor's vehicles at minimum security Institutions.
- .6 Private vehicles of construction employees will not be allowed within the security wall or fence of medium or maximum security institutions without the authorization of the Director.
- .7 With the approval of the Director, certain equipment may be permitted to remain on the construction site overnight or over the weekend. This equipment must be securely locked, with the battery removed. The Director may require that the equipment be secured with a chain and padlock to another solid object.

20 MOVEMENT OF CONSTRUCTION EMPLOYEES ON INSTITUTIONAL PROPERTY

- .1 Subject to the requirements of good security, the Director will permit the Contractor and his employees as much freedom of action and movement as is possible.
- .2 However, notwithstanding paragraph above, the Director may:
 - .1 Prohibit or restrict access to any part of the Institution.
 - .2 Require that in certain areas of the Institution, either during the entire construction project or at certain intervals, construction employees only be allowed access when accompanied by a member of the CSC security staff or PWGSC Construction Escort Officer.
- .3 During the lunch and coffee/health breaks, all construction employees will remain within the construction site. Construction employees are not permitted to eat in the Institution cafeteria and dining room.

21 SURVEILLANCE AND INSPECTION

- .1 Construction activities and all related movement of personnel and vehicles will be subject to surveillance and inspection by CSC security staff members to ensure that established security requirements are met.
- .2 CSC staff members will ensure that an understanding of the need to carry out surveillance and inspections, as specified above, is established among construction employees and maintained throughout the construction project.

22 STOPPAGE OF WORK

- .1 The director may request at any time that the contractor, his employees, sub-contractors and their employees not enter or leave the work site immediately due to a security situation occurring within the Institution. The contractor's site supervisor will note the name of the staff member giving the instruction, the time of the request and obey the order as quickly as possible.
 - .2 The contractor shall advise the Departmental Representative of this interruption of the work within 24 hours.
-

23 CONTACT WITH INMATES

- .1 Unless specifically authorized, it is forbidden to come into contact with inmates, to talk with them, to receive objects from them or to give them objects. Any employee doing any of the above will be removed from the site and his security clearance revoked.
- .2 Digital cameras (or any other type) are not allowed on CSC property.
- .3 Notwithstanding the above paragraph, if the director approves of the use of cameras, it is strictly forbidden to take pictures of inmates, of CSC staff members or of any part of the Institution other than those required as part of this contract.

24 COMPLETION OF CONSTRUCTION PROJECT

- .1 Upon completion of the construction project or, when applicable, the takeover of a facility, the Contractor shall remove all remaining construction material, tools and equipment that are not specified to remain in the Institution as part of the construction contract.

END OF SECTION

1. REFERENCES

- .1 Government of Canada.
 - .1 Canada Labour Code - Part II
 - .2 Canada Occupational Health and Safety Regulations.
- .2 National Building Code of Canada (NBC):
 - .1 Part 8, Safety Measures at Construction and Demolition Sites.
- .3 Canadian Standards Association (CSA):
 - .1 CSA Z797-2009, Code of Practice for Access Scaffold.
 - .2 CSA S269.1-1975 (R2003), Falsework for Construction Purposes.
 - .3 CSA-S350-M1980, Code of Practice for Safety in Demolition of Structures.
- .4 Fire Protection Engineering Services (HRSDC):
 - .1 FCC No. 301, Standard for Construction Operations.
 - .2 FCC No. 302, Standard for Welding and Cutting.
- .5 American National Standards Institute (ANSI):
 - .1 ANSI A10.3, Operations – Safety Requirements for Powder-Actuated Fastening Systems.
- .6 Province of British Columbia:
 - .1 Workers Compensation Act Part 3 - Occupational Health and Safety.
 - .2 Occupational Health and Safety Regulation.

2. RELATED SECTIONS

- .1 Refer to the following current NMS sections as required:
 - .1 Submittals procedures: Section 01 01 50

3. WORKERS' COMPENSATION BOARD COVERAGE

- .1 Comply fully with the Workers' Compensation Act, regulations and orders made pursuant thereto, and any amendments up to the completion of the work.
- .2 Maintain Workers' Compensation Board coverage during the term of the Contract, until and including the date that the Certificate of Final Completion is issued.

4. COMPLIANCE WITH REGULATIONS

- .1 PWGSC may terminate the Contract without liability to PWGSC where the Contractor, in the opinion of PWGSC, refuses to comply with a requirement of the Workers' Compensation Act or the Occupational Health and Safety Regulations.
-

for POD 1 & Principal Entrance

- .2 It is the Contractor's responsibility to ensure that all workers are qualified, competent and certified to perform the work as required by the Workers' Compensation Act or the Occupational Health and Safety Regulations.

5. SUBMITTALS

- .1 Make submittals in accordance with Section 01 01 50.
- .2 Work effected by submittal shall not proceed until review is complete.
- .3 Submit the following:
 - .1 Health and Safety Plan.
 - .2 Copies of reports or directions issued by Federal and Provincial health and safety inspectors.
 - .3 Copies of incident and accident reports.
 - .4 Complete set of Material Safety Data Sheets (MSDS), and all other documentation required by Workplace Hazardous Materials Information System (WHMIS) requirements.
 - .5 Emergency procedures.
- .4 The Departmental Representative will review the Contractor's site-specific project Health and Safety Plan and emergency procedures, and provide comments to the Contractor within 5 days after receipt of the plan. Revise the plan as appropriate and resubmit to Departmental Representative
- .5 Medical surveillance: where prescribed by legislation, regulation or safety program, Submit certification of medical surveillance for site personnel prior to commencement of work, and submit additional certifications for any new site personnel to Departmental Representative.
- .6 Submission of the Health and Safety Plan, and any revised version, to the Departmental Representative is for information and reference purposes only. It shall not:
 - .1 Be construed to imply approval by the Departmental Representative.
 - .2 Be interpreted as a warranty of being complete, accurate and legislatively compliant.
 - .3 Relieve the Contractor of his legal obligations for the provision of health and safety on the project.

6. RESPONSIBILITY

- .1 Assume responsibility as the Prime Contractor for work under this contract.
 - .2 Be responsible for health and safety of persons on site, safety of property on site and for protection of persons adjacent to site and environment to extent that they may be affected by conduct of Work.
 - .3 Comply with and enforce compliance by employees with safety requirements of Contract
-

for POD 1 & Principal Entrance

- . documents, applicable Federal, Provincial, Territorial and local statutes, regulations, and ordinances, and with site-specific Health and Safety Plan.

7. HEALTH AND SAFETY COORDINATOR

- .1 The Health and Safety Coordinator must:
 - .1 Be responsible for completing all health and safety training, and ensuring that personnel that do not successfully complete the required training are not permitted to enter the site to perform work.
 - .2 Be responsible for implementing, daily enforcing, and monitoring the site-specific Health and Safety Plan.
 - .3 Be on site during execution of work.

8. GENERAL CONDITIONS

- .1 Provide safety barricades and lights around work site as required to provide a safe working environment for workers and protection for pedestrian and vehicular traffic.
- .2 Ensure that non-authorized persons are not allowed to circulate in designated construction areas of the work site.
 - .1 Provide appropriate means by use of barricades, fences, warning signs, traffic control personnel, and temporary lighting as required.
 - .2 Secure site at night time or provide security guard as deemed necessary to protect site against entry.

9. PROJECT/SITE CONDITIONS

- .1 Work at site will involve contact with:
 - .1 Inmates of the Institution.

10. REGULATORY REQUIREMENTS

- .1 Comply with specified codes, acts, bylaws, standards and regulations to ensure safe operations at site.
- .2 In event of conflict between any provision of the above authorities, the most stringent provision will apply. Should a dispute arise in determining the most stringent requirement, the Departmental Representative will advise on the course of action to be followed.

11. WORK PERMITS

- .1 Obtain specialty permits related to project before start of work.
-

12. FILING OF NOTICE

- .1 The Contractor is to complete and submit a Notice of Project as required by Provincial authorities.

13. HEALTH AND SAFETY PLAN

- .1 Conduct a site-specific hazard assessment based on review of Contract documents, required work, and project site. Identify any known and potential health risks and safety hazards.
 - .2 Prepare and comply with a site-specific project Health and Safety Plan based on hazard assessment, including, but not limited to, the following:
 - .1 Primary requirements:
 - .1 Contractor's safety policy.
 - .2 Identification of applicable compliance obligations.
 - .3 Definition of responsibilities for project safety/organization chart for project.
 - .4 General safety rules for project.
 - .5 Job-specific safe work, procedures.
 - .6 Inspection policy and procedures.
 - .7 Incident reporting and investigation policy and procedures.
 - .8 Occupational Health and Safety Committee/Representative procedures.
 - .9 Occupational Health and Safety meetings.
 - .10 Occupational Health and Safety communications and record keeping procedures.
 - .2 Summary of health risks and safety hazards resulting from analysis of hazard assessment, with respect to site tasks and operations which must be performed as part of the work.
 - .3 List hazardous materials to be brought on site as required by work.
 - .4 Indicate Engineering and administrative control measures to be implemented at the site for managing identified risks and hazards.
 - .5 Identify personal protective equipment (PPE) to be used by workers.
 - .6 Identify personnel and alternates responsible for site safety and health.
 - .7 Identify personnel training requirements and training plan, including site orientation for new workers.
 - .3 Develop the plan in collaboration with all subcontractors. Ensure that work/activities of subcontractors are included in the hazard assessment and are reflected in the plan.
 - .4 Revise and update Health and Safety Plan as required, and re-submit to the Departmental Representative.
 - .5 Departmental Representative's review: the review of Health and Safety Plan by Public Works and Government Services Canada (PWGSC) shall not relieve the Contractor of responsibility for errors or omissions in final Health and Safety Plan or of responsibility for meeting all requirements of construction and Contract documents.
-

for POD 1 & Principal Entrance

14. EMERGENCY PROCEDURES

- .1 List standard operating procedures and measures to be taken in emergency situations. Include an evacuation plan and emergency contacts (i.e. names/telephone numbers) of:
 - .1 Designated personnel from own company.
 - .2 Regulatory agencies applicable to work and as per legislated regulations.
 - .3 Local emergency resources.
 - .4 Departmental Representative and PWGSC site staff.
- .2 Include the following provisions in the emergency procedures:
 - .1 Notify workers and the first-aid attendant, of the nature and location of the emergency.
 - .2 Evacuate all workers safely.
 - .3 Check and confirm the safe evacuation of all workers.
 - .4 Notify the fire department or other emergency responders.
 - .5 Notify adjacent workplaces or residences which may be affected if the risk extends beyond the workplace.
 - .6 Notify Departmental Representative and PWGSC site staff.
- .3 Provide written rescue/evacuation procedures as required for, but not limited to:
 - .1 Work at high angles.
 - .2 Work in confined spaces or where there is a risk of entrapment.
 - .3 Work with hazardous substances.
 - .4 Underground work.
 - .5 Work on, over, under and adjacent to water.
 - .6 Workplaces where there are persons who require physical assistance to be moved.
- .4 Design and mark emergency exit routes to provide quick and unimpeded exit.
- .5 Revise and update emergency procedures as required, and re-submit to the Departmental Representative.

15. HAZARDOUS PRODUCTS

- .1 Comply with requirements of Workplace Hazardous Materials Information System (WHMIS) regarding use, handling, storage and disposal of hazardous materials, and regarding labeling and provision of Material Safety Data Sheets (MSDS) acceptable to the Departmental Representative and in accordance with the Canada Labour Code.
 - .2 Where use of hazardous and toxic products cannot be avoided:
 - .1 Advise Departmental Representative beforehand of the product(s) intended for use. Submit applicable MSDS and WHMIS documents as per Section 01 01 50.
 - .2 In conjunction with Departmental Representative, schedule to carry out work during "off hours" when tenants have left the building.
 - .3 Provide adequate means of ventilation.
-

16. REMOVAL OF LEAD CONTAINING PAINTS

- .1 All paints containing TCLP lead concentrations above 5 ppm are classified as hazardous.
- .2 Carry out demolition activities involving lead-containing paints in accordance with applicable Provincial or Territorial regulations.

17. ELECTRICAL SAFETY REQUIREMENTS

- .1 Comply with authorities and ensure that, when installing new facilities or modifying existing facilities, all electrical personnel are completely familiar with existing and new electrical circuits and equipment and their operation.
 - .1 Before undertaking any work, coordinate required energizing and de-energizing of new and existing circuits with Departmental Representative.
 - .2 Maintain electrical safety procedures and take necessary precautions to ensure safety of all personnel working under this Contract, as well as safety of other personnel site.

18. ELECTRICAL LOCKOUT

- .1 Develop, implement and enforce use of established procedures to provide electrical lockout and to ensure the health and safety of workers for every event where work must be done on any electrical circuit or facility.
- .2 Prepare the lockout procedures in writing, listing step-by-step processes to be followed by workers, including how to prepare and issue the request/authorization form. Have procedures available for review upon request by the Departmental Representative.
- .3 Keep the documents and lockout tags at the site and list in a log book for the full duration of the Contract. Upon request, make such data available for viewing by Departmental Representative or by any authorized safety representative.

19. OVERLOADING

- .1 Ensure no part of work is subjected to a load which will endanger its safety or will cause permanent deformation.

20. SCAFFOLDING

- .1 Design, construct and maintain scaffolding in a rigid, secure and safe manner, in accordance with CSA-Z797-2009 and B.C. Occupational Health and Safety Regulations.

21. POWDER-ACTIVATED DEVICES

- .1 Use powder-actuated devices in accordance with ANSI A10.3 only after receipt of written permission from the Departmental Representative.
-

for POD 1 & Principal Entrance

22. FIRE SAFETY AND HOT WORK

- .1 Obtain Departmental Representative's authorization before any welding, cutting or any other hot work operations can be carried out on site.
- .2 Hot work includes cutting/melting with use of torch, flame heating roofing kettles, or other open flame devices and grinding with equipment which produces sparks.

23. FIRE SAFETY REQUIREMENTS

- .1 Store oily/paint-soaked rags, waste products, empty containers and materials subject to spontaneous combustion in ULC approved, sealed containers and remove from site on a daily basis.
- .2 Handle, store, use and dispose of flammable and combustible materials in accordance with the National Fire Code of Canada.

24. FIRE PROTECTION AND ALARM SYSTEM

- .1 Fire protection and alarm systems shall not be:
 - .1 Obstructed.
 - .2 Shut off.
 - .3 Left inactive at the end of a working day or shift.
- .2 Do not use fire hydrants, standpipes and hose systems for purposes other than firefighting.
- .3 Be responsible/liable for costs incurred from the fire department, the building owner and the tenants, resulting from false alarms.

25. UNFORESEEN HAZARDS

- .1 Should any unforeseen or peculiar safety-related factor, hazard or condition become evident during performance of the work, immediately stop work and advise the Departmental Representative verbally and in writing.

26. POSTED DOCUMENTS

- .1 Post legible versions of the following documents on site:
 - .1 Health and Safety Plan.
 - .2 Sequence of work.
 - .3 Emergency procedures.
 - .4 Site drawing showing project layout, locations of the first-aid station, evacuation route and marshaling station, and the emergency transportation provisions.
 - .5 Notice of Project.
 - .6 Floor plans or site plans.
-

for POD 1 & Principal Entrance

- .7 Notice as to where a copy of the Workers' Compensation Act and Regulations are available on the work site for review by employees and workers.
 - .8 Workplace Hazardous Materials Information System (WHMIS) documents.
 - .9 Material Safety Data Sheets (MSDS).
 - .10 List of names of Joint Health and Safety Committee members, or Health and Safety Representative, as applicable.
-
- .2 Post all Material Safety Data Sheets (MSDS) on site, in a common area, visible to all workers and in locations accessible to tenants when work of this Contract includes construction activities adjacent to occupied areas.
 - .3 Postings should be protected from the weather, and visible from the street or the exterior of the principal construction site shelter provided for workers and equipment, or as approved by the Departmental Representative.

27. MEETINGS

- .1 **Attend health and safety pre-construction meeting and all subsequent meetings called by the Departmental Representative.**

28. CORRECTION OF NON-COMPLIANCE

- .1 Immediately address health and safety non-compliance issues identified by the Departmental Representative.
- .2 Provide Departmental Representative with written report of action taken to correct non-compliance with health and safety issues identified.
- .3 The Departmental Representative may issue a "stop work order" if non-compliance of health and safety regulations is not corrected immediately or within posted time. The General Contractor/subcontractors will be responsible for any costs arising from such a "stop work order".

END OF SECTION

Part 1 General

1.1 RELATED SECTIONS

- .1 Section 11 19 60 – Detention Fabrications.

1.2 REFERENCES

- .1 American Society for Testing and Materials International, (ASTM).
 - .1 ASTM D790-02, Test Methods for Flexural Properties of Unreinforced and
 - .2 Reinforced Plastics and Electrical Insulating Materials.
 - .3 .ASTM D1929-96(R2001)e1, Test Method for Determining Ignition Temperature of Plastics.
 - .4 ASTM D2240-02b, Test Method for Rubber Property - Durometer Hardness.
 - .5 ASTM E84-01, Test Method for Surface Burning Characteristics of Building Materials.
 - .6 ASTM F1233-98, Test Method for Security Glazing Materials and Systems.
- .2 Canadian General Standards Board (CGSB).
 - .1 CAN/CGSB-12.1-M90, Tempered or Laminated Safety Glass.

1.3 CONTROL POST DESIGN REQUIREMENTS

- .1 Performance Requirements:
 - .1 The exterior and interior glazing panels and the polycarbonate core are not laminated (POD 1).
 - .2 The glazing must be such that the glass has no visible distortion when seeing through the assembly.
 - .3 At the gunport locations provide sealant each side between the exterior and interior panels and the polycarbonate core such that no contaminants can penetrate between the panels.

1.4 SUBMITTALS

- .1 Product Data:
 - .1 Submit manufacturer's printed product literature, specifications and data sheet in accordance with Section 01 01 50 - Submittal Procedures.
- .2 Provide shop drawings for layout of gunports.
- .3 Samples:
 - .1 Submit 300 x 300 mm size samples of each type of glass and plastic.
- .4 Manufacturer's Instructions:
 - .1 Submit manufacturer's installation instructions.

1.5 QUALITY ASSURANCE

- .1 Certificates: product certificates signed by manufacturer certifying materials comply with specified performance characteristics and criteria and physical requirements.
 - .2 Mock-ups:
 - .1 Construct mock-up of plastic glazing.
 - .2 Mock-up will be used:
 - .1 To judge workmanship, substrate preparation, operation of equipment and material application.
 - .3 Locate where directed by Departmental Representative.
 - .4 Allow 24 hours for inspection of mock-up before proceeding with work.
 - .5 When accepted, mock-up will demonstrate minimum standard of quality required for this work. Approved mock-up may remain as part of finished work.
 - .3 Pre-installation Meetings: conduct pre-installation meeting to verify project requirements, manufacturer's installation instructions and manufacturer's warranty
-

requirements.

1.6 WASTE MANAGEMENT AND DISPOSAL

- .1 Separate and recycle waste materials in accordance with Section 01 01 50 – Waste Management and Disposal.
- .2 Divert metal cut-offs from landfill by disposal into on-site metal recycling bin.
- .3 Divert uninstalled materials for reuse at nearest used building materials facility or similar type facility. Divert unused caulking and sealant materials from landfill through disposal at special wastes depot.
- .4 Unused or damaged glazing materials are not recyclable and must not be diverted to municipal recycling programs.
- .5 Remove form site and dispose of packaging materials at appropriate recycling facilities.
- .6 Dispose of corrugated cardboard, polystyrene and plastic packaging material in appropriate on-site bin for recycling in accordance with site waste management program.

Part 2 Products

2.1 MATERIALS: FLAT GLASS - POD 1

- .1 Safety glass: to CAN/CGSB-12.1, transparent, thickness as scheduled.
 - .1 Type 2-tempered.
 - .2 Class B-float. Category 11-fully tempered.
- .2 Polycarbonate security glazing:
 - .1 Thickness 32mm.
 - .2 Colour: Clear.
 - .3 Ballistic performance: to ASTM F1233.
 - .4 Flexural strength: to ASTM D790.
 - .5 Surface burning characteristics for flame and smoke spread: to ASTM E84.
 - .6 Self ignition characteristics: to ASTM D1929.
 - .7 Acceptable Product: Lexan Lexguard SP 1250 for Type 3 glazing and Lexan 9034 for Type 4 and 9 glazing.

2.2 MATERIALS: FLAT GLASS - PRINCIPAL ENTRANCE

- .1 Polycarbonate security glazing:
 - .1 Thickness 32mm.
 - .2 Colour: Clear.
 - .3 Ballistic performance: to ASTM F1233.
 - .4 Flexural strength: to ASTM D790.
 - .5 Surface burning characteristics for flame and smoke spread: to ASTM E84.
 - .6 Self ignition characteristics: to ASTM D1929.
 - .7 Acceptable Product: Lexan Lexguard SP 1250 for Type 3 glazing and Lexan 9034 for Type 4 and 9 glazing.
 - .8 Mar Guard film both sides.

2.3 ACCESSORIES

- .1 Setting blocks: Neoprene, 80-90 Shore A durometer hardness to ASTM D2240, to suit glazing method, glass light weight and area.
- .2 Spacer shims: Neoprene, 50-60 Shore A durometer hardness to ASTM D2240, 75 mm long x one half height of glazing stop x thickness to suit application. Self adhesive on one face.
- .3 Glazing tape:
 - .1 Preformed butyl compound with integral resilient tube spacing device, 10-15 Shore A durometer hardness to ASTM D2240; coiled on release paper; black colour

Part 3 Execution

3.1 MANUFACTURER'S INSTRUCTIONS

.1 Compliance: Comply with manufacturer's written data, including product technical bulletins, product catalogue installation instructions, product carton installation instructions, and data sheets.

3.2 EXAMINATION

.1 Verify that openings for glazing are correctly sized and within tolerance.
.2 Verify that surfaces of glazing channels or recesses are clean, free of obstructions, and ready to receive glazing.

3.3 PREPARATION

.1 Clean contact surfaces with solvent and wipe dry.
.2 Seal porous glazing channels or recesses with substrate compatible primer or sealer.
.3 Prime surfaces scheduled to receive sealant.

3.4 INSTALLATION: INTERIOR - DRY METHOD (TAPE AND TAPE)

.1 Perform work in accordance with IGMA installation methods.
.2 Cut glazing tape to length and set against permanent stops, projecting 1.6 mm above sight line.
.3 Place setting blocks at 1/4 points, with edge block maximum 150 mm from corners.
.4 Rest glazing on setting blocks and push against tape for full contact at perimeter of light or unit.
.5 Place glazing tape on free perimeter of glazing in same manner described.
.6 Install removable stop without displacement of tape. Exert pressure on tape for full continuous contact.
.7 Knife trim protruding tape.

3.5 CLEANING

.1 Perform cleaning after installation to remove construction and accumulated environmental dirt. Remove traces of primer, caulking.
.2 Remove glazing materials from finish surfaces.
.3 Remove labels after work is complete.
.4 Clean glass using approved non-abrasive cleaner in accordance with manufacturer's instructions.
.5 Upon completion of installation, remove surplus materials, rubbish, tools and equipment barriers.

3.6 PROTECTION OF FINISHED WORK

.1 After installation, mark light with an "X" by using non-marking removable plastic tape.

END OF SECTION

GENERAL

1.1 RELATED WORK

- .1 Detention Fabrication (Gun Ports): Section 11 19 60

1.2 SAMPLES AND PRODUCT DATA

- .1 Submit colour sample of paint type specified.
- .2 Submit full records of all products used. List each product and include the following:
- .1 Finish formula designation.
 - .2 Product type and use.
 - .3 CGSB number.
 - .4 Manufacturer's product number.
 - .5 Colour number.
 - .6 Manufacturer's Material Safety Data Sheets (MSDS).
 - .7 Maximum VOC classification.
 - .8 Ecologo certification.

1.3 ENVIRONMENTAL REQUIREMENTS

- .1 Do not apply paint finish in areas where dust is being generated.
- .2 Provide paint products certified to meet the requirements of the Environmental Choice Program, Department of the Environment.
- .3 Submit CSA Certification Reports that products proposed for use are certified under the Environmental Choice program. Water-based paints are to be certified to ECP-07-89, and solvent-based paints are to be certified to ECP-12-89.
- .4 Comply with requirements of the Workplace Hazardous Materials Information System (WHMIS) regarding use, handling, storage and disposal of hazardous materials.
- .5 Provide continuous ventilation during and after paint application. of paint. Run ventilation system 24 hours per day during installation, and provide continuous ventilation for 7 days after completion of application of paint.
- .6 Apply paint finishes only when temperature at location of installation can be satisfactorily maintained within manufacturer's recommendations.
- .7 Substrate and ambient temperature must be within limits prescribed in paint standard and by manufacturer, to the approval of the Departmental Representative.
- .8 Provide temporary heating where permanent facilities are not available to maintain minimum recommended temperatures.
- .9 Apply paint only when surface to be painted is dry, properly cured and adequately prepared.
-

1.4 MAINTENANCE DATA

- .1 Record final paint types, manufacturers' names and colours selected, and provide data to Departmental Representative.

1.5 QUALITY ASSURANCE

- .1 Do paint work to standards of the Master Painters Association of B.C. (MPA).
- .2 Retain purchase orders, invoices and other documents to prove that all materials utilized in this Contract meet requirements of the specifications. Produce documents when requested by Departmental Representative.
- .3 Standard of acceptance:
 - .1 No defects visible from a distance of 1000 mm at 90° to surface.
 - .2 Final coat to exhibit uniformity of colour and sheen across full surface area.

2 PRODUCTS

2.1 MATERIALS

- .1 Paint materials: to CGSB Standards listed in Finishing Formulae.
- .2 Paint materials for each coating formula to be products of only one manufacturer.

3 EXECUTION

3.1 PREPARATION OF SURFACES

- .1 Touch up shop paint primer on steel with CAN/CGSB 1.40M-89 to CGSB 85-GP-14M-1978.

3.2 APPLICATION

- .1 Sand and dust between each coat to remove defects visible from distance up to 1.5 m.

3.4 FINISHES

- .1 Formula 12: for primed ferrous metal surfaces apply:
 - one coat spot priming
 - one coat latex primer General Paint #51-050.
 - two coats acrylic semi-gloss water base enamel.
 - Match Existing

END OF SECTION

Part 1 General

1.1 SECTION INCLUDES

- .1 Detention Metal Fabricated Gun Port as shown on the drawings and as specified herein. Includes installation of 9 new Gun Ports and 6 reused Gun Ports. **Gun Ports to be Provided by Others, this section is for reference only except with regards to installation and painting.** See Part 2.3.2 & Part 3. Refer to Appendix 1.

1.2 REFERENCES

- .1 Canadian General Standards Board (CGSB)
 - .1 CAN/CGSB-1.40-97, Anti-corrosive Structural Steel Alkyd Primer.
 - .2 CAN/CGSB-1.181-99, Ready-Mixed, Organic Zinc-Rich Coating.
- .2 Canadian Standards Association (CSA International)
 - .1 CAN/CSA-G40.20/G40.21-04, General Requirements for Rolled or Welded Structural Quality Steel.
 - .2 CSA W48-01, Filler Metals and Allied Materials for Metal Arc Welding
 - .3 CSA W59-03, Welded Steel Construction (Metal Arc Welding).

1.3 SUBMITTALS

- .1 Product Data:
 - .1 Submit manufacturer's printed product literature, specifications and data sheet in accordance with Section 01 01 50 - Submittal Procedures.
 - .2 Manufacturer's catalogue literature may be submitted in lieu of shop drawings provided installation is of a typical nature not requiring special details and approval has been obtained from the Departmental Representative to do so. Failure to obtain the Departmental Representative's approval will not relieve the Contractor from obligation to submit detailed shop drawings
- .2 Shop Drawings
 - .1 Submit shop drawings in accordance with Section 01 01 50 - Submittal Procedures.
 - .2 Indicate materials, core thicknesses, finishes, connections, joints, method of anchorage, number of anchors, supports, reinforcement, details, and accessories.
 - .3 Shop drawings shall show construction details of specialties, general arrangements, typical and special installation conditions, materials, connections, attachments, anchorage, location of exposed fastenings and interface with adjacent materials.

1.4 QUALITY ASSURANCE

- .1 Certificates: Product certificates signed by manufacturer certifying materials comply with specified performance characteristics and criteria and physical requirements.
- .2 Departmental Representative to review 1st installation in each building and approve before completion.

1.5 DELIVERY, STORAGE, AND HANDLING

- .1 Packing, Shipping, Handling and Unloading:
 - .1 Deliver, store, handle and protect materials in accordance with Section 01 01 50.
- .2 Storage and Protection:
 - .1 Cover exposed stainless steel surfaces with pressure sensitive heavy protection paper or apply strippable plastic coating, before shipping to job site.
 - .2 Leave protective covering in place until final cleaning of building. Provide instructions for removal of protective covering.
- .3 Detention Manufactured Specialties
 - .1 Conform strictly to the manufacturer's printed instructions covering delivery storage and handling of specialties at the job site.

.2 Handle specialties with care to prevent damage to specialties and building finishes during movement on site. Keep protective coverings in place until removal is necessary for installation or building is ready for final acceptance.

3 Store specialties in a protected area away from environmental and physical conditions that would damage or otherwise impair the performance of the products.

Part 2 Products (provided by Departmental Representative)

2.1 MATERIALS

- .1 Steel sections and plates: to CAN/CSA-G40.20/G40.21, Grade 350W.
- .2 Welding materials: to CSA W59.
- .3 Welding electrodes: to CSA W48 Series.
- .4 Bolts and anchor bolts: to ASTM A307.
- .5 Detention Manufactured Specialties
 - .1 Specialties shall be provided with all of the necessary anchorages, fastenings, trims, closures, shims, braces, setting compounds, isolation coatings and hardware required for a complete and finished installation.

2.2 FABRICATION

- .1 Fabricate work square, true, straight and accurate to required size, with joints closely fitted and properly secured. Provide strict quality control over fabrication to assure fabrication and assembly for ± 1.5 mm from location indicated in the contract documents.
- .2 Where possible, fit and shop assemble work, ready for erection.
- .3 Ensure exposed welds are continuous for length of each joint.
 - .1 Welds shall be designed for flush smooth finish.
 - .2 Minor imperfections will be allowed only where practical during primer application.
 - .3 Defects which would be visible in the finished work shall be ground out, filled with welding material and ground flush.
 - 4 Grind all welds smooth. Welds shall be neat, complete and free of voids.
- .4 Ease exposed edges to approximate 0.5 mm uniform radius.
- .5 Provide holes required for other work secured to or passing through architecturally exposed steel.
- .6 All copes, mitres and butt cuts in surfaces exposed to view shall be made with no gaps if detailed to be open joints or in uniform contact if detailed w/o gaps.
- .7 Weld in such a manner as to avoid distortion, discolouration or damage to the members..
- .8 Weld interior work continuously along the entire line of contact..
- .9 Drill for countersunk screws if exposed to view unless otherwise shown or accepted by the Departmental Representative
- .10 Locate holes in so as not to cause appreciable reduction in the strength of members.
- .11 Reinforce all work to suit the purpose for which it is intended and to withstand design loads..
- .12 Joints in materials shall be cut to form fine joints flush with adjacent surfaces.
- .13 Provide suitable temporary bracing as required to maintain alignment during shipment and installation.

2.3 FINISHES

- .1 Shop coat primer for painted steel: to CAN/CGSB-1.40.
 - .2 **Finish paint. Contractor to finish paint.**
-

2.4 SHOP PREPARATION FOR PAINTING

- .1 Clean metal of all loose mill scale, rust, oil, dirt and all other foreign matter.
- .2 Clean interior metal to be painted in accordance with SSPC_SPI_Solvent Cleaning followed with SSPC SP.6 Commercial Blast Cleaning.
- .3 Remove or repair sharp edges, burrs, weld spatter and other defects to steel members prior to application of primers.

2.3 SHOP PAINTING

- .1 Apply one shop coat of primer to metal items. Ensure that primer is applied within 8 hours of completion of surface preparations.
- .2 Use primer unadulterated, as prepared by manufacturer. Paint on dry surfaces, free from rust, scale, grease. Do not paint when temperature is lower than 7 degrees C.
- .3 If the correct primer is not applied by this section of the Work, this section is responsible for removal of the incorrect primer, re-conditioning the surface and applying the correct primer as specified, including removal and re-installation of the affected work as required.
- .4 Primer applied to surfaces not properly prepared in accordance with specified SSPC preparations will be rejected by the Departmental Representative and shall be removed, brought up to the specified requirements and re-installed by the Contractor at no additional cost to the Contract.

Part 3 Execution (Installation by Contractor)

3.1 INSTALLATION

- .1 Detention Fabricated Specialties
 - .1 Install Gun Ports in strict accordance with the manufacturer's directions.
 - .2 Workers shall be skilled in the work assigned to them and familiar with installation procedures.
 - .3 Install specialties to perform the function intended, adjust all operating components for smooth unrestricted operation.
 - .4 Secure specialties permanently or as required to permit removal for maintenance.

3.2 CLEANING

- .1 Perform cleaning after installation to remove construction and accumulated environmental dirt.
- .2 Remove all protective labels just prior to final acceptance and clean products using cleaners as recommended by the manufacturer.
- .3 Remove all debris, equipment and surplus materials entirely from site upon completion of work.

END OF SECTION

Gun Ports

For POD 1 & Principal Entrance
Kent Institution
Project No. R.066998.001

APPENDIX 1

Gun Port
Gun Port Section

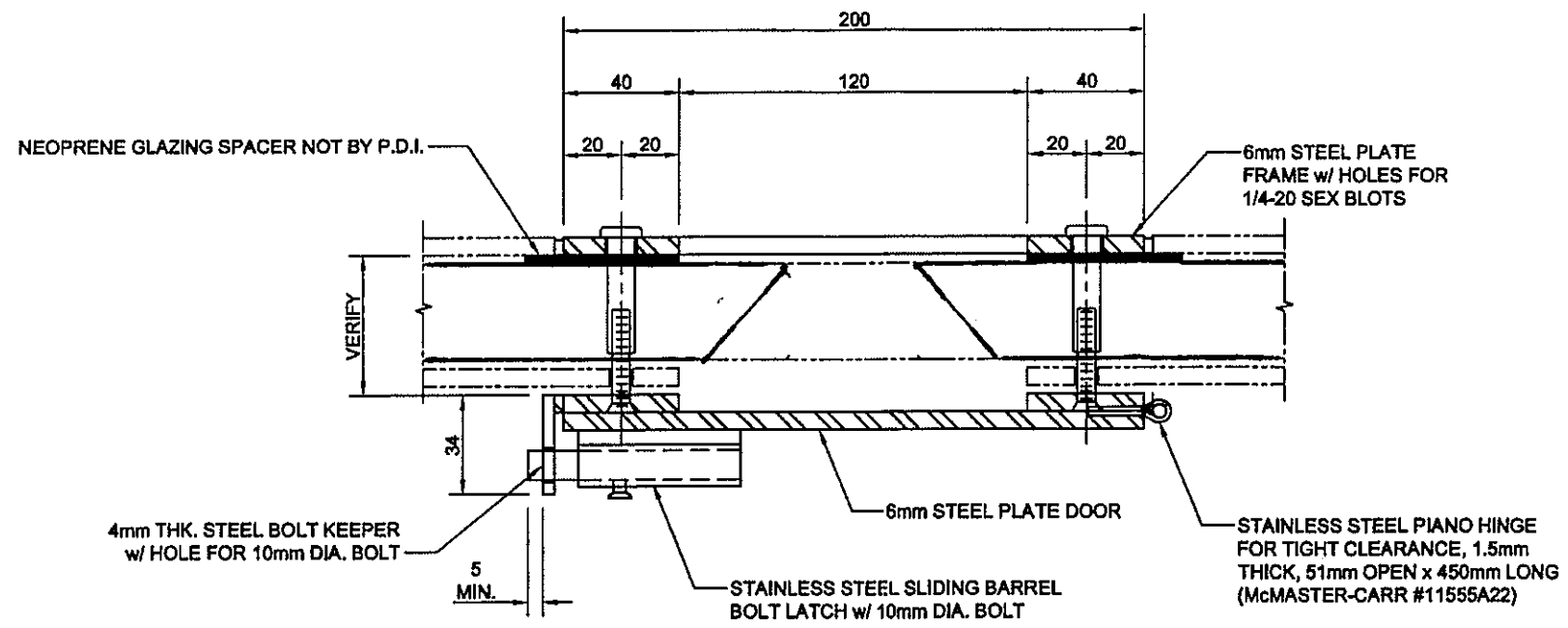

SECTION B-B

DRAWING: GUN PORT SECTION

CP-5000

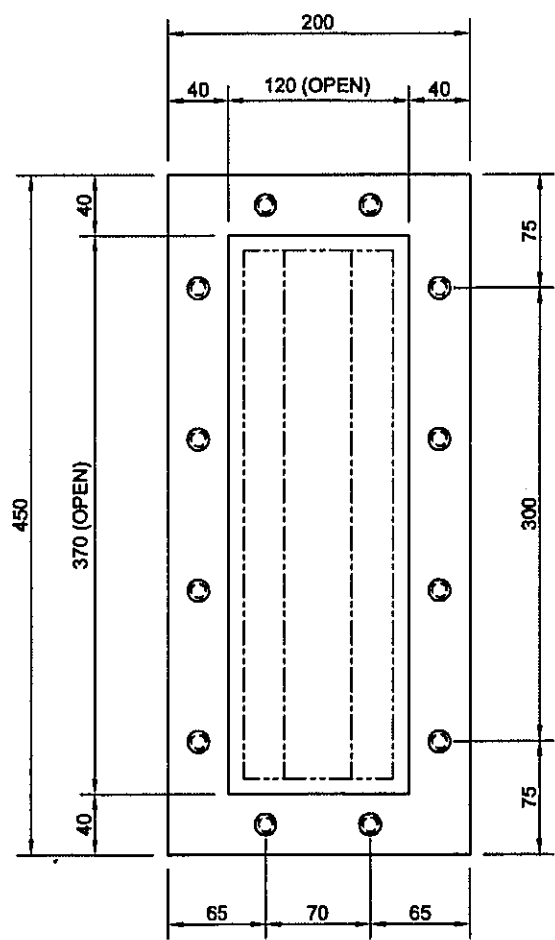

ELEVATION
(INMATE CORRIDOR SIDE)

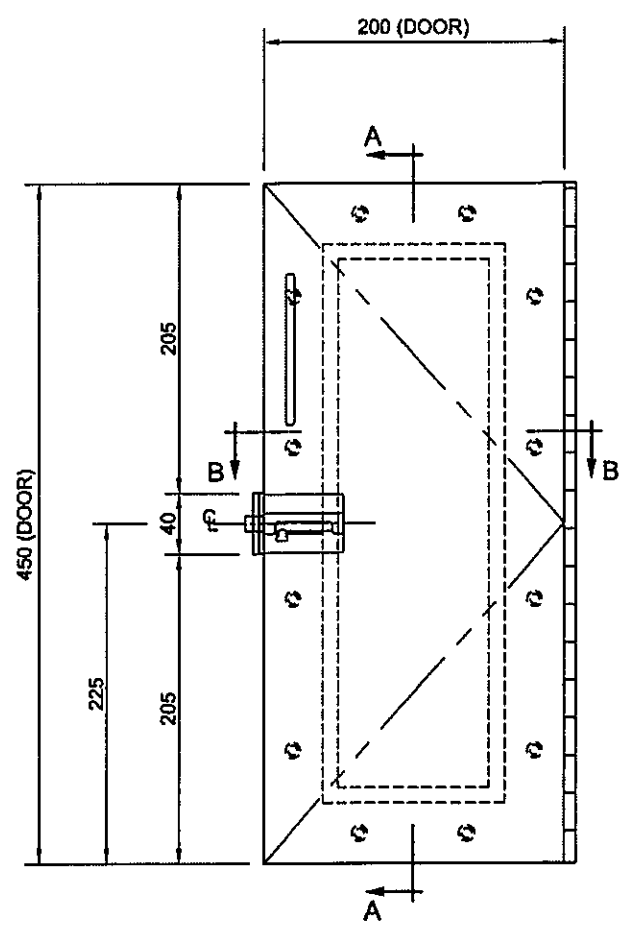

ELEVATION
(CONTROL POST SIDE)

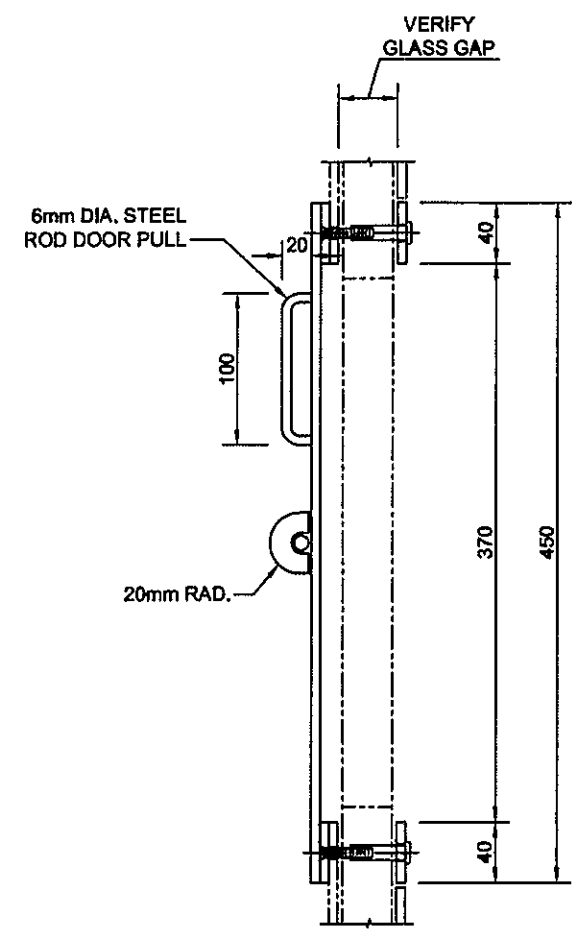

SECTION A-A

GUN PORT

- NOTES:
 1. SMOOTH ALL SHARP EDGES.
 2. FACTORY PRIMER FINISH ON ALL MILD STEEL COMPONENTS (GRAY).
 3. SEE SHEET GP-5001 FOR SECTION B-B.

GP 5000

PROJECT: KENT INSTITUTION - AGASSIZ, B.C.
 DRAWING: GUN PORT