

Annex 1 – Cabinets and Millwork

Dimensions are provided for quantity purpose only. Millwork installation to be coordinated with the installation of the light fixtures to make sure they don't overlap. See shop drawings for more details.

- All gables to be a standard width size of 16"
- All end gables to be a consistent height
- Gun boxes must be mounted to end gables w carriage bolts and maintain constant depth & height in each room

Type A - The following rooms are standard (approx. 60" cabinet/wardrobe):

208, 209, 212, 213, 216, 220, 221, 231, 236, 240, 241, 244, 245, 248, 249

Type B - The following rooms have a column (approx. 44" cabinet /wardrobe)

- End drywall is 16" or more
- Cabinets will not have a long hang area-rod to hang above shelving
- Cabinets will mount on the same wall as standard type

210, 211, 214, 215, 218, 219, 222, 223, 229, 233, 242, 243, 251, 247, 234, 238, 246

Type C - The following rooms have a column/stub wall to short/narrow opening

- Cabinet/wardrobes will vary in size (approx. 30" to 44")
- All of these cabinet/wardrobes are to be installed on the end wall
- Maintain depth & height as well as gun box installation
- In-fill the void space with drywall or an extension of the millwork top shelf in the void cabinet area (prevent items falling over) - both methods are acceptable
- Due to the narrow opening of these areas, cabinets need to be installed in steps
- Side gables must be installed firmly to **max width** of space c/w top shelf & rod
- Back to be installed behind or in between
- Lower shelf cabinet to be built to make the diagonal turn, installed with void side filler strips , top shelf to be fit & installed on site

217, 225, 254, 256, 257, 258, 259, 260, 261, 262, 263, 264, 265, 266, 267, 268, 269, 270, 271, 272, 273

Desk Unit:

All 53 desk units are standard.

Headboards:

Headboard sizes might vary from room to room. It is the contractor responsibility to take proper measurements.

- STANDARD
- COLUMN
- COLUMN / STUD

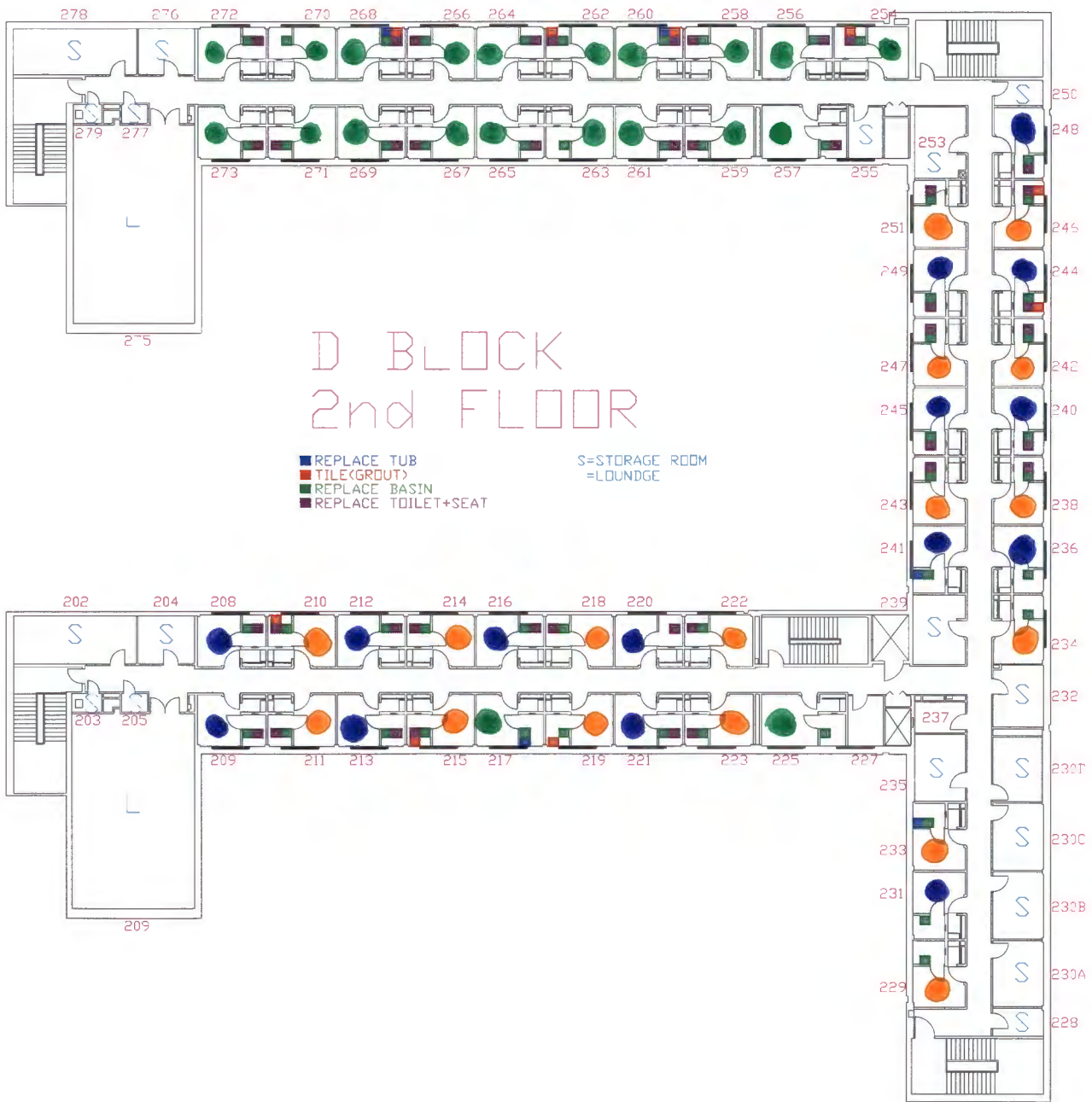

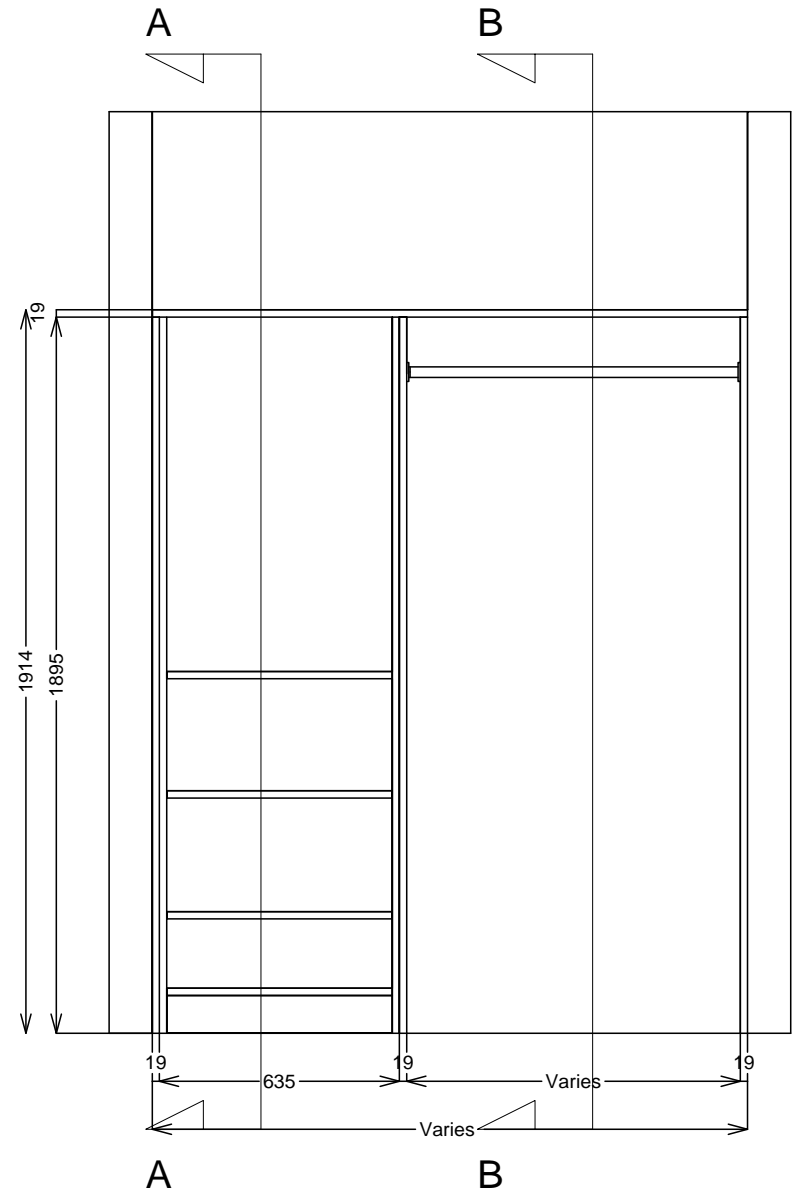
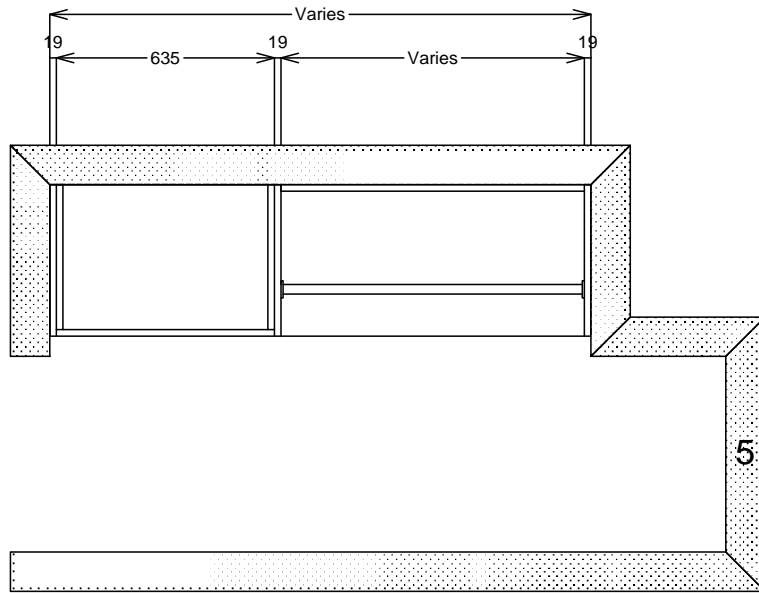

Cabinet Construction: 19mm Roseburg W752 Tierra Linea

Edge Banding: 0.5mm PVC Tierra Linea

CLOSET Type A

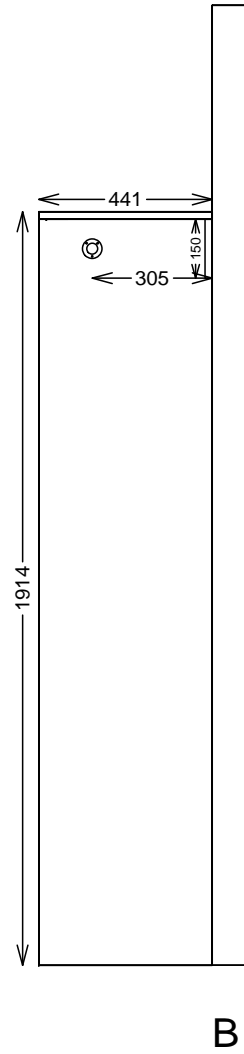
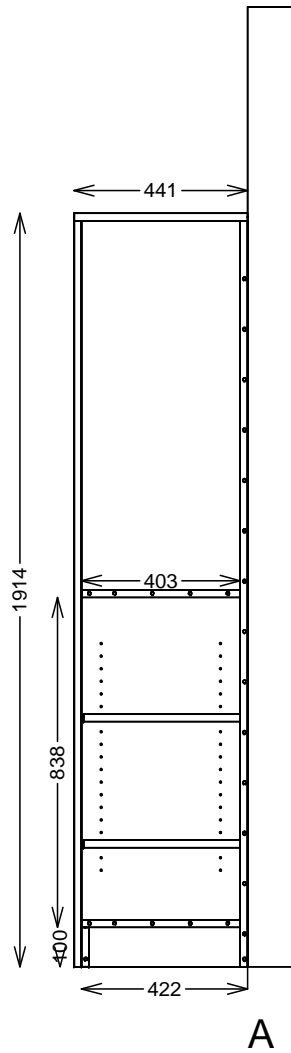

Cabinet Construction: 19mm Roseburg W752 Tierra Linea
 Edge Banding: 0.5mm PVC Tierra Linea

CLOSET TYPE A

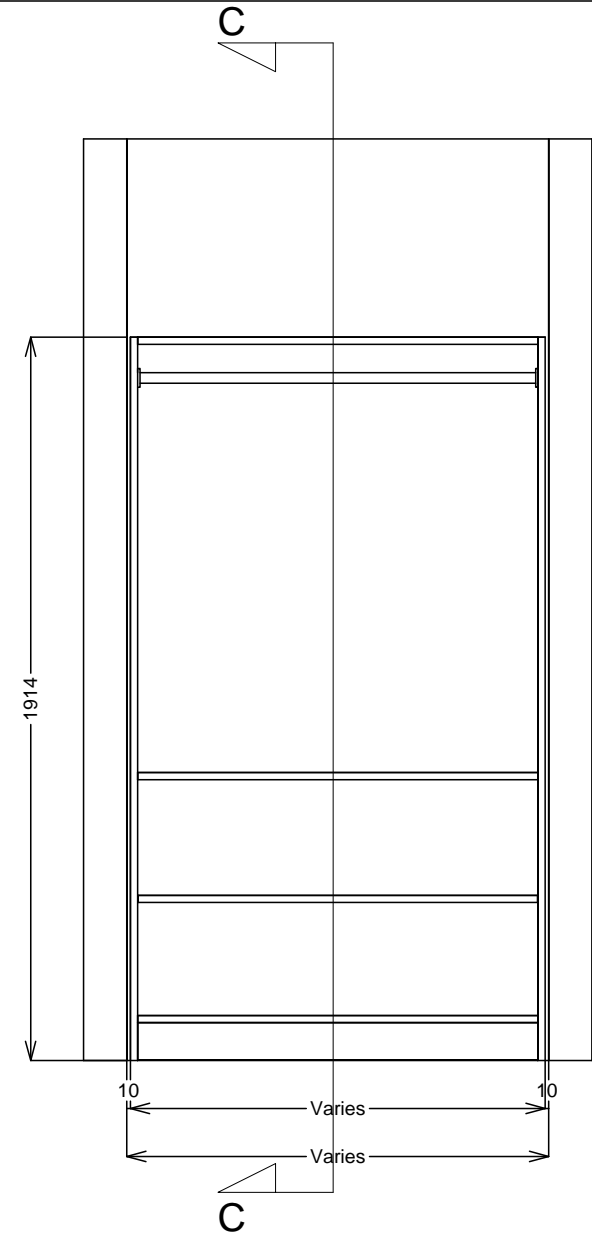
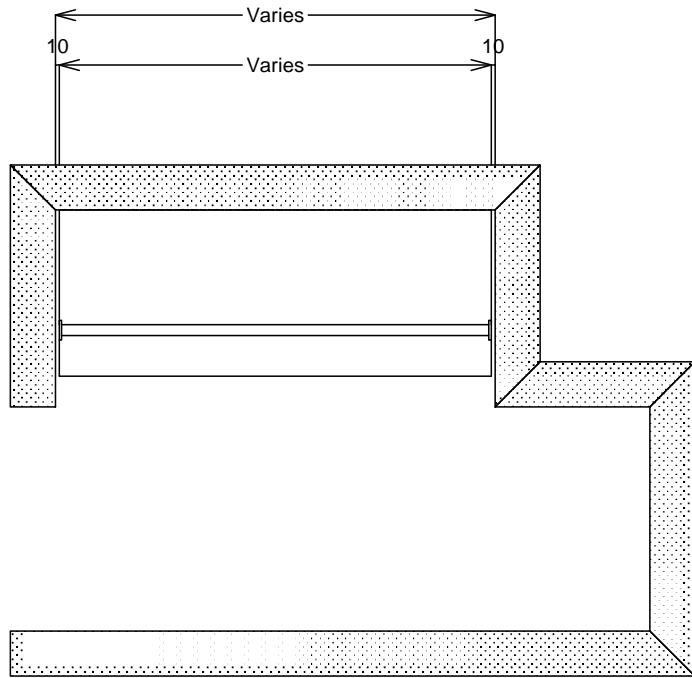

Cabinet Construction: 19mm Roseburg W752 Tierra Linea
 Edge Banding: 0.5mm PVC Tierra Linea

CLOSET Type B

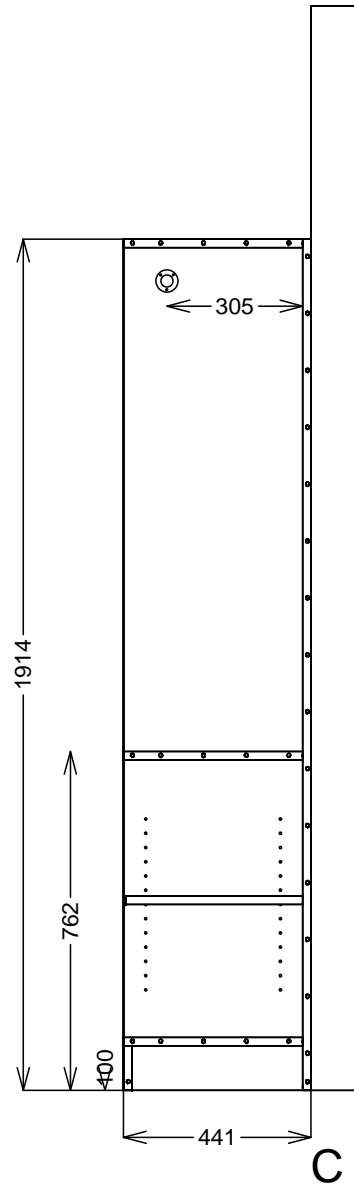

Cabinet Construction: 19mm Roseburg W752 Tierra Linea
 Edge Banding: 0.5mm PVC Tierra Linea

CLOSET Type B

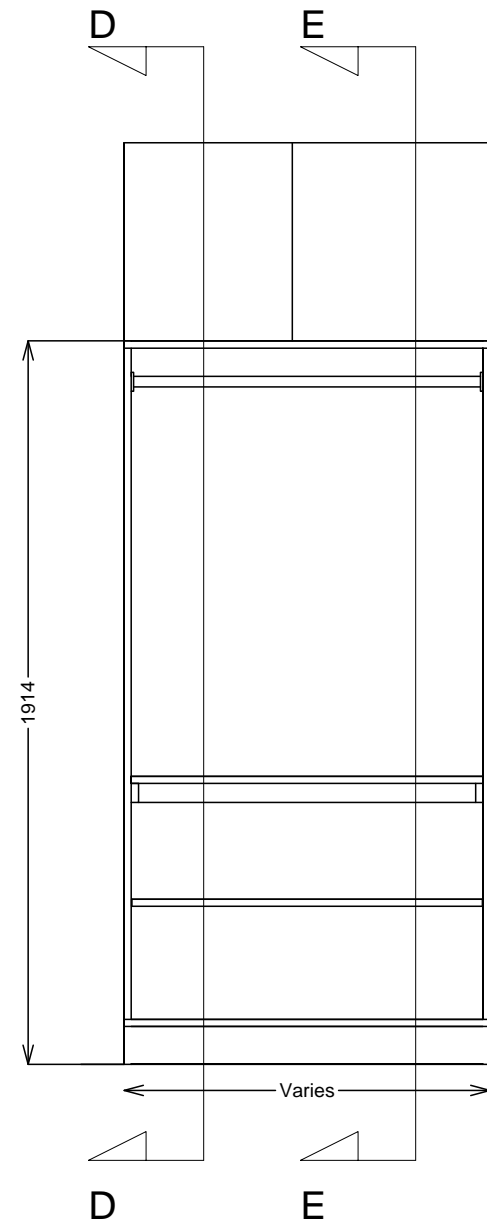
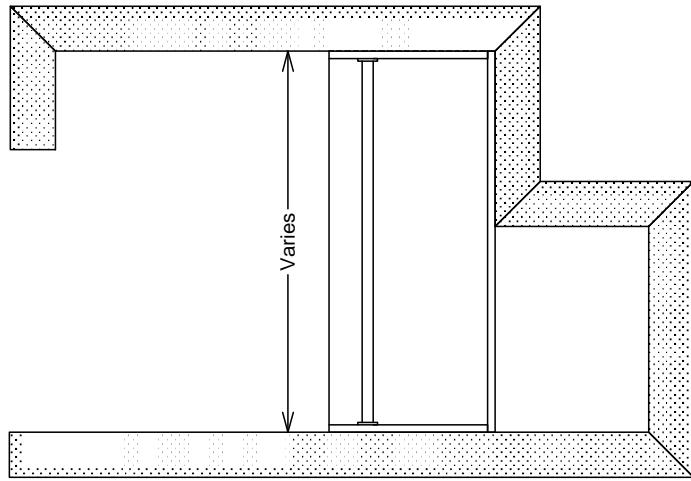

Cabinet Construction: 19mm Roseburg W752 Tierra Linea
 Edge Banding: 0.5mm PVC Tierra Linea

CLOSET Type C

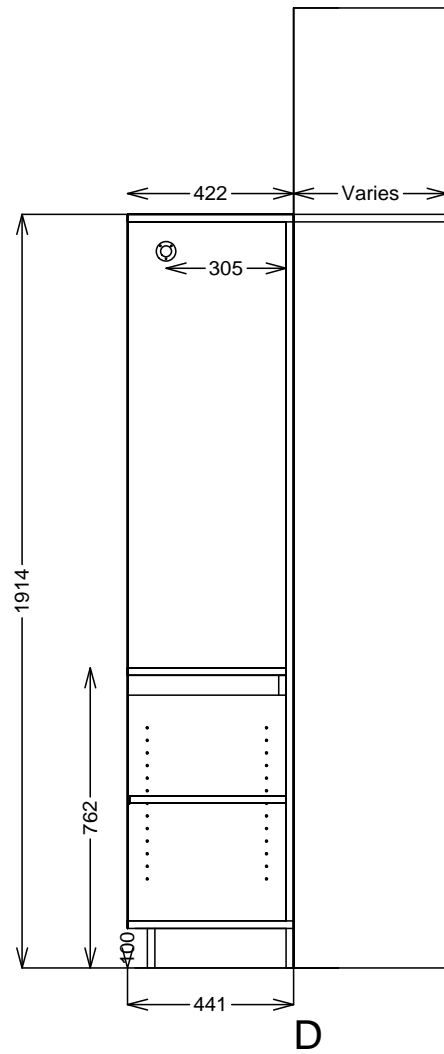
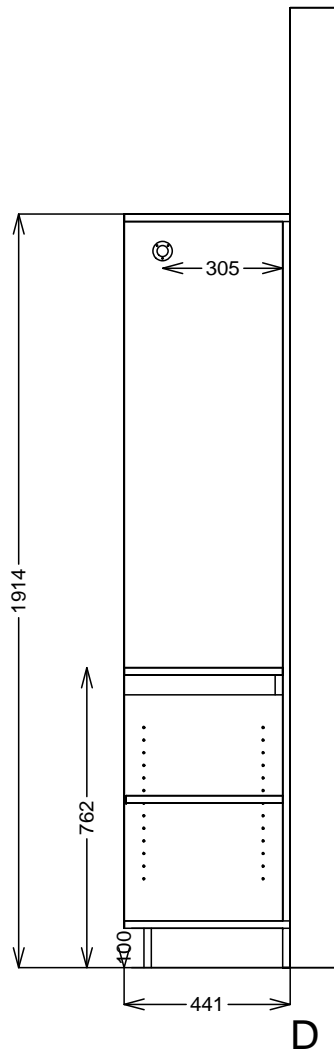

Cabinet Construction: 19mm Roseburg W752 Tierra Linea
 Edge Banding: 0.5mm PVC Tierra Linea

CLOSET Type C

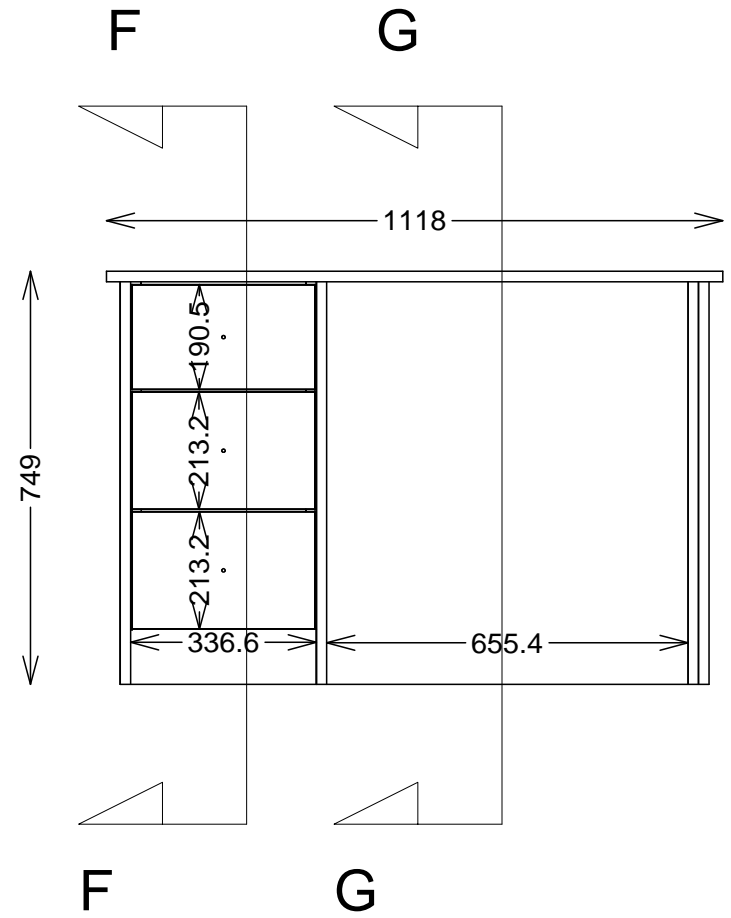
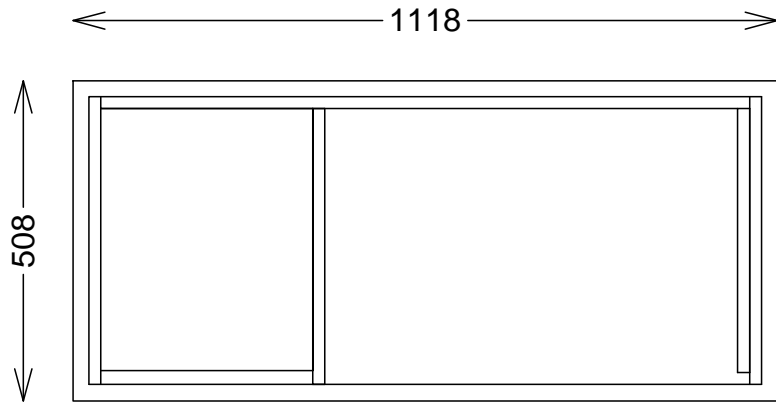

Cabinet Construction: 19mm Roseburg W752 Tierra Linea
 Edge Banding: 0.5mm PVC Tierra Linea
 Drawer Construction: 16mm Roseburg W752 Tierra Linea
 Drawer Slides: Accuride 3832C14
 Pulls: Richelieu #4923175

DESK UNIT

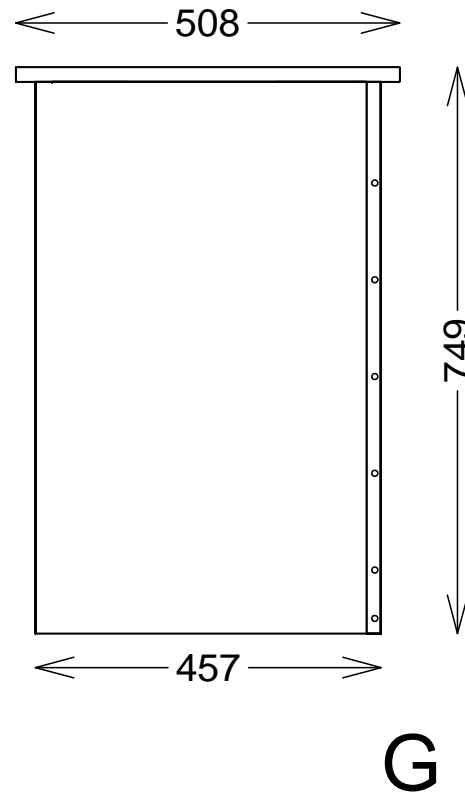
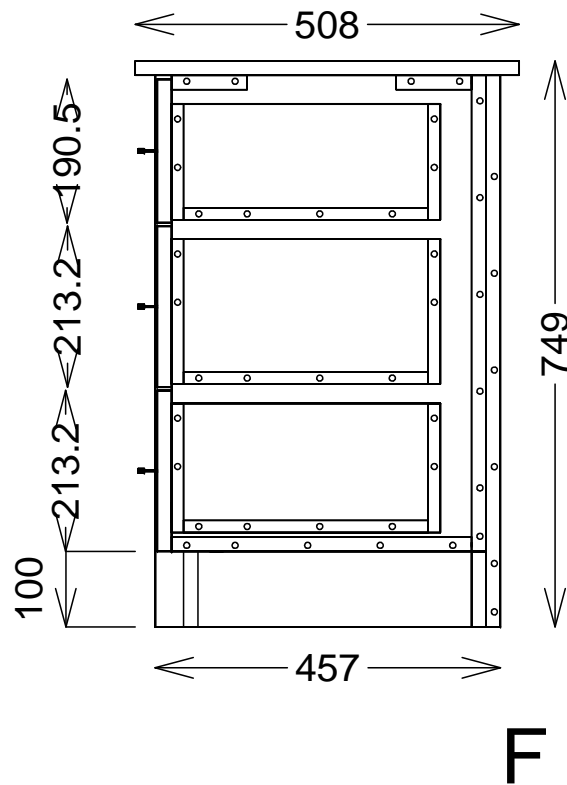

Cabinet Construction: 19mm Roseburg W752 Tierra Linea
 Edge Banding: 0.5mm PVC Tierra Linea
 Drawer Construction: 16mm Roseburg W752 Tierra Linea
 Drawer Slides: Accuride 3832C14
 Pulls: Richelieu #BP34013170

DESK UNIT