



INVITATION TO TENDER

RETURN BIDS TO:

Bid Receiving / Agriculture and Agri-Food Canada

Agriculture and Agri-Food Canada
 Central Experimental Farm (CEF)
 Bid Receiving (Main Entrance)
 K.W. Neatby building
 960 Carling Avenue
 Ottawa, Ontario K1A 0C6

TENDER TO:

Agriculture and Agri-Food Canada

We hereby offer to sell to Her Majesty the Queen in right of Canada, in accordance with the terms and conditions set out herein, referred to herein or attached hereto, the construction listed herein and on any attached sheets at the price(s) set out therefor.

Comments

This documents contains a security requirement

ISSUING OFFICE

Agriculture and Agri-Food Canada
 CEF Integrated Services
 K.W. Neatby building
 960 Carling Avenue
 Ottawa, Ontario
 K1A 0C6

Title Roof Replacement, building 22	
Solicitation No. 14-1054	Date 2014-07-18
Client Reference No. MCE14-529452	
File No. 14-1054	
Solicitation Closes: Monday, August 11, 2014, at 02:00 PM, EDT.	
F.O.B <input type="radio"/> Plant <input checked="" type="radio"/> Destination <input type="radio"/> Other	
Address Enquiries to: Jean-Pierre Simard	
Title: Senior Contracts officer	
Email: jean-pierre.simard@agr.gc.ca	
Telephone Number Ext. 613 759-6157	Fax Number
Destination Agriculture and Agri-Food Canada 960 Carling Avenue, building 22 Ottawa, Ontario K1A 0C6	

Instructions: See Herein

Delivery Required	Delivery Offered
Vendor / Firm Name and Address	
Telephone Number Ext.	Fax Number
Name and title of person authorized to sign on behalf of Vendor / Firm (type or print)	
Signature	Date



SPECIAL INSTRUCTIONS TO BIDDERS (SI)

- SI01 Bid Documents
- SI02 Enquiries during the Solicitation Period
- SI03 Mandatory Site Visit
- SI04 Revision of Bid
- SI05 Bid Results
- SI06 Insufficient Funds
- SI07 Bid Validity Period
- SI08 Construction Documents
- SI09 Web Sites
- SI10 Personnel Security Requirements

SI01 BID DOCUMENTS

- 1) The following are the bid documents:
 - (a) INVITATION TO TENDER - Page 1 form AAFC / AAC5323-E;
 - (b) SPECIAL INSTRUCTIONS TO BIDDERS form AAFC / AAC5301-E;
 - (c) GENERAL INSTRUCTIONS TO BIDDERS form AAFC / AAC5313-E;
 - (d) Clauses and Conditions identified in "CONTRACT DOCUMENTS";
 - (e) Drawings and Specifications;
 - (f) BID AND ACCEPTANCE form AAFC / AAC5320-E and any Appendices attached thereto; and,
 - (g) Any amendment issued prior to solicitation closing.

Submission of a bid constitutes acknowledgement that the Bidder has read and agrees to be bound by these documents.

SI02 ENQUIRIES DURING THE SOLICITATION PERIOD

- 1) Enquiries regarding this bid must be submitted in writing to the Contracting Officer named on the INVITATION TO TENDER - Page 1 as early as possible within the solicitation period. Except for the approval of alternative materials as described in G113 of the GENERAL INSTRUCTIONS TO BIDDERS, enquiries should be received no later than five (5) calendar days prior to the date set for solicitation closing to allow sufficient time to provide a response. Enquiries received after that time may not result in an answer being provided.
- 2) To ensure consistency and quality of the information provided to Bidders, the Contracting Officer shall examine the content of the enquiry and shall decide whether or not to issue an amendment.
- 3) All enquiries and other communications related to this bid sent throughout the solicitation period are to be directed ONLY to the Contracting Officer named on the INVITATION TO TENDER - Page 1. Non-compliance with this requirement during the solicitation period can, for that reason alone, result in disqualification of a bid.

SI03 MANDATORY SITE VISIT

- 1) There will be a site visit on wednesday, July, 30, 2014 at 10:00 AM PM EDT.

SPECIAL INSTRUCTIONS TO BIDDERS (Continued)

Interested bidders are to meet at:

CEF Ottawa
K.W. Neatby building
960 Carling Avenue
Ottawa, Ontario
K1A 0C6

The site visit for this project is MANDATORY. The representative of the bidder will be required to sign the Site Visit Attendance Sheet at the site visit. Bids submitted by Bidders who have not signed the attendance sheet will not be accepted.

SI04 REVISION OF BID

- 1) A bid may be revised by letter or facsimile in accordance with G109 of the GENERAL INSTRUCTIONS TO BIDDERS. The facsimile number for receipt of revisions is 613 759-7005 .

SI05 BID RESULTS

- 1) Following bid closing, bid results may be obtained from the bid receiving office by calling telephone number 613 759-6157 ext. .

SI06 INSUFFICIENT FUNDING

- 1) In the event that the lowest compliant bid exceeds the amount of funding allocated for the Work, Canada in its sole discretion may:
 - (a) cancel the solicitation; or
 - (b) obtain additional funding and award the Contract to the Bidder submitting the lowest compliant bid; and/or
 - (c) negotiate a reduction in the bid price and/or scope of work of not more than 15% with the Bidder submitting the lowest compliant bid. Should an agreement satisfactory to Canada not be reached, Canada shall exercise option (a) or (b).

SI07 BID VALIDITY PERIOD

- 1) Canada reserves the right to seek an extension to the bid validity period prescribed in Clause 4 of the BID AND ACCEPTANCE Form. Upon notification in writing from Canada, Bidders shall have the option to either accept or reject the proposed extension.
- 2) If the extension referred to in paragraph 1) of SI07 is accepted, in writing, by all those who submitted bids, then Canada shall continue immediately with the evaluation of the bids and its approvals processes.
- 3) If the extension referred to in paragraph 1) of SI07 is not accepted in writing by all those who submitted bids then Canada shall, at its sole discretion, either:
 - (a) continue to evaluate the bids of those who have accepted the proposed extension and seek the necessary approvals; or
 - (b) cancel the invitation to bid.

SPECIAL INSTRUCTIONS TO BIDDERS (Continued)

- 4) The provisions expressed herein do not in any manner limit Canada's rights in law or under GI10 of the GENERAL INSTRUCTIONS TO BIDDERS.

SI08 CONSTRUCTION DOCUMENTS

- 1) The successful contractor will be provided with one paper copy of the sealed and signed plans, the specifications and the amendments upon acceptance of the offer. Additional copies, up to a maximum of one (1), will be provided free of charge upon request by the Contractor. Obtaining more copies shall be the responsibility of the Contractor including costs.

SI09 WEB SITES

The connection to some of the Web sites in the solicitation documents is established by the use of hyperlinks. The following is a list of the addresses of the Web sites:

Treasury Board Appendix L, Acceptable Bonding Companies

<http://www.tbs-sct.gc.ca/pol/doc-eng.aspx?id=14494§ion=text#appL>

Canadian economic sanctions

<http://www.international.gc.ca/sanctions/index.aspx?lang=eng>

SI10 PERSONNEL SECURITY REQUIREMENTS

- 1) The successful Bidder's personnel, as well as any subcontractor and its personnel, who are required to perform any part of the work pursuant to the subsequent contract, must meet the following contract security requirements:
 - Personnel who are required to perform any part of the work must EACH hold a valid personnel security screening at the level of RELIABILITY STATUS, granted or approved by Agriculture and Agri-Food Canada. Until the security screening of the personnel has been completed satisfactorily by Agriculture and Agri-Food Canada, the Contractor/Subcontractor personnel MAY NOT perform contract work. Each of the proposed staff must complete "Security Clearance Form" (TBS 330-23E) upon request from Canada.



GENERAL INSTRUCTIONS TO BIDDERS

- GI01 Completion of Bid
- GI02 Identity or Legal Capacity of the Bidder
- GI03 Applicable Taxes
- GI04 Capital Development and Redevelopment Charges
- GI05 Registry and Pre-qualification of Floating Plant
- GI06 Listing of Subcontractors and Suppliers
- GI07 Bid Security Requirements
- GI08 Submission of Bid
- GI09 Revision of Bid
- GI10 Rejection of Bid
- GI11 Bid Costs
- GI12 Compliance with Applicable Laws
- GI13 Approval of Alternative Materials
- GI14 Conflict of Interest – Unfair Advantage

GI01 COMPLETION OF BID

- 1) The bid shall be:
 - (a) submitted on the BID AND ACCEPTANCE FORM provided by AAFC with the bid package or on a clear and legible reproduced copy of such BID AND ACCEPTANCE FORM that must be identical in content and format to the BID AND ACCEPTANCE FORM provided by AAFC;
 - (b) based on the Bid Documents listed in the Special Instructions to Bidders;
 - (c) correctly completed in all respects;
 - (d) signed, with an original signature, by a duly authorized representative of the Bidder; and
 - (e) accompanied by
 - (i) bid security as specified in GI07; and
 - (ii) any other document or documents specified elsewhere in the solicitation where it is stipulated that said documents are to accompany the bid.
- 2) Subject to paragraph 6) of GI10, any alteration to the pre-printed or pre-typed sections of the Bid and Acceptance Form, or any condition or qualification placed upon the bid shall be cause for disqualification. Alterations, corrections, changes or erasures made to statements or figures entered on the Bid and Acceptance Form by the Bidder shall be initialed by the person or persons signing the bid. Alterations, corrections, changes or erasures that are not initialed shall be deemed void and without effect.
- 3) Unless otherwise noted elsewhere in the Bid Documents, facsimile copies of bids are not acceptable.

GENERAL INSTRUCTIONS TO BIDDERS (Continued)

GI02 IDENTITY OR LEGAL CAPACITY OF THE BIDDER

- 1) In order to confirm the authority of the person or persons signing the bid or to establish the legal capacity under which the Bidder proposes to enter into Contract, any Bidder who carries on business in other than its own personal name shall, if requested by Canada, provide satisfactory proof of
 - (a) such signing authority; and
 - (b) the legal capacity under which it carries on business;

prior to contract award. Proof of signing authority may be in the form of a certified copy of a resolution naming the signatory(ies) that is (are) authorized to sign this bid on behalf of the corporation or partnership. Proof of legal capacity may be in the form of a copy of the articles of incorporation or the registration of the business name of a sole proprietor or partnership.

GI03 APPLICABLE TAXES

- 1) "Applicable Taxes" means the Goods and Services Tax (GST), the Harmonized Sales Tax (HST), and any provincial tax, by law, payable by Canada such as, the Quebec Sales Tax (QST) as of April 1, 2013.

GI04 CAPITAL DEVELOPMENT AND REDEVELOPMENT CHARGES

- 1) For the purposes of GC1.8 LAWS, PERMITS AND TAXES in the General Conditions of the Contract, only fees or charges directly related to the processing and issuing of building permits shall be included. The Bidder shall not include any monies in the bid amount for special municipal development, redevelopment or other fees or charges which a municipal authority may seek as a prerequisite to the issuance of building permits.

GI05 REGISTRY AND PRE-QUALIFICATION OF FLOATING PLANT

- 1) Dredges or other floating plant to be used in the performance of the Work must be of Canadian registry. For dredges or other floating plant that are not of Canadian make or manufacture, the Bidder must obtain a certificate of qualification from Industry Canada and this certificate must accompany the bid. Plant so qualified by Industry Canada may be accepted on this project.

GI06 LISTING OF SUBCONTRACTORS AND SUPPLIERS

- 1) Notwithstanding any list of Subcontractors that the Bidder may be required to submit as part of the bid, the Bidder shall, within 48 hours of receipt of a notice to do so, submit all information requested in the said notice including the names of Subcontractors and Suppliers for the part or parts of the Work listed. Failure to do so shall result in the disqualification of its bid.

GI07 BID SECURITY REQUIREMENTS

- 1) The Bidder shall submit bid security with the bid in the form of a bid bond or a security deposit in an amount that is equal to not less than 10 percent of the bid amount. Applicable Taxes shall not be included when calculating the amount of any bid security that may be required. The maximum amount of bid security required with any bid is \$2,000,000.00.

GENERAL INSTRUCTIONS TO BIDDERS (Continued)

- 2) A bid bond shall be in an approved form <http://www.tbs-sct.gc.ca/pol/doc-eng.aspx?id=14494§ion=text#appS>, properly completed, with original signature(s) and issued by an approved company whose bonds are acceptable to Canada either at the time of solicitation closing or as identified in Treasury Board Appendix L: [Acceptable Bonding Companies](#).
- 3) A security deposit shall be an original, properly completed, signed where required and be either:
 - (a) a bill of exchange, bank draft or money order made payable to the Receiver General for Canada and certified by an approved financial institution or drawn by an approved financial institution on itself; or
 - (b) bonds of, or unconditionally guaranteed as to principal and interest by, the Government of Canada;
- 4) For the purposes of subparagraph 3) (a) of GI07
 - (a) a bill of exchange is an unconditional order in writing signed by the Bidder and addressed to an approved financial institution, requiring the said institution to pay, on demand, at a fixed or determinable future time a sum certain of money to, or to the order of, the Receiver General for Canada;
 - (b) if a bill of exchange, bank draft or money order is certified by or drawn on an institution or corporation other than a chartered bank, it must be accompanied by proof that the said institution or corporation meets at least one of the criteria described in subparagraph 4.c. of GI07, either by letter or by a stamped certification on the bill of exchange, bank draft or money; and
 - (c) An approved financial institution is:
 - (i) a corporation or institution that is a member of the Canadian Payments Association as defined in the [Canadian Payments Act](#);
 - (ii) a corporation that accepts deposits that are insured, to the maximum permitted by law, by the Canada Deposit Insurance Corporation or the "Autorité des marchés financiers";
 - (iii) a corporation that accepts deposits from the public if repayment of the deposit is guaranteed by Her Majesty the Queen in right of a province;
 - (iv) a corporation, association or federation incorporated or organized as a credit union or co-operative credit society that conforms to the requirements of a credit union which are more particularly described in paragraph 137(6) of the [Income Tax Act](#); or
 - (v) Canada Post Corporation.
- 5) Bonds referred to in subparagraph 3)(b) of GI07 shall be provided on the basis of their market value current at the date of solicitation closing, and shall be:
 - (a) payable to bearer;
 - (b) accompanied by a duly executed instrument of transfer of the bonds to the Receiver General for Canada in the form prescribed by the Domestic Bonds of Canada Regulations; or
 - (c) registered as to principal or as to principal and interest in the name of the Receiver General for Canada pursuant to the Domestic Bonds of Canada Regulations.

GENERAL INSTRUCTIONS TO BIDDERS (Continued)

- 6) As an alternative to a security deposit an irrevocable standby letter of credit is acceptable to Canada and the amount shall be determined in the same manner as a security deposit referred to above.
- 7) An irrevocable standby letter of credit referred to in paragraph 6) of GI07 shall
 - (a) be an arrangement, however named or described, whereby a financial institution (the "Issuer") acting at the request and on the instructions of a customer (the "Applicant) or on its own behalf,
 - (i) is to make a payment to, or to the order of, the Receiver General for Canada as the beneficiary;
 - (ii) is to accept and pay bills of exchange drawn by the Receiver General for Canada;
 - (iii) authorizes another financial institution to effect such payment or accept and pay such bills of exchange; or
 - (iv) authorizes another financial institution to negotiate against written demand(s) for payment provided that the terms and conditions of the letter of credit are complied with;
 - (b) state the face amount which may be drawn against it;
 - (c) state its expiry date;
 - (d) provide for sight payment to the Receiver General for Canada by way of the financial institution's draft against presentation of a written demand for payment signed by the Departmental Representative identified in the letter of credit by his/her office;
 - (e) provide that more than one written demand for payment may be presented subject to the sum of those demands not exceeding the face value of the letter of credit;
 - (f) provide that it is subject to the International Chamber of Commerce (ICC) Uniform Customs and Practice (UCP) for Documentary Credits, 2007 Revision, ICC Publication No. 600; pursuant to the ICC UCP; a credit is irrevocable even if there is no indication to that effect; and
 - (g) be issued or confirmed, in either official language, by a financial institution which is a member of the Canadian Payments Association and is on the letterhead of the Issuer or Confirmer. The format is left to the discretion of the Issuer or Confirmer.
- 8) Bid security shall lapse or be returned as soon as practical following:
 - (a) the solicitation closing date, for those Bidders submitting non-compliant bids; and
 - (b) the administrative bid review, for those Bidders submitting compliant bids ranked fourth to last on the schedule of bids; and
 - (c) the award of contract, for those Bidders submitting the second and third ranked bids; and
 - (d) the receipt of contract security, for the successful Bidder; or
 - (e) the cancellation of the solicitation, for all Bidders.
- 9) Notwithstanding the provisions of paragraph 8) of GI07 and provided more than three compliant bids have been received, if one or more of the bids ranked third to first is withdrawn or rejected

GENERAL INSTRUCTIONS TO BIDDERS (Continued)

for whatever reason then Canada reserves the right to hold the security of the next highest ranked compliant bid in order to retain the bid security of at least three valid and compliant bids.

GI08 SUBMISSION OF BID

- 1) The Bid and Acceptance Form, duly completed, and the bid security shall be enclosed and sealed in an envelope provided by the Bidder, and shall be addressed and submitted to the office designated on the INVITATION TO TENDER Form for the receipt of bids. The bid must be received on or before the date and time set for solicitation closing.
- 2) Unless otherwise specified in the Special Instructions to Bidders
 - (a) the bid shall be in Canadian currency;
 - (b) exchange rate fluctuation protection is not offered; and
 - (c) any request for exchange rate fluctuation protection shall not be considered.
- 3) Prior to submitting the bid, the Bidder shall ensure that the following information is clearly printed or typed on the face of the bid envelope:
 - (a) Solicitation Number;
 - (b) Name of Bidder;
 - (c) Return address; and
 - (d) Closing Date and Time.
- 4) Timely and correct delivery of bids is the sole responsibility of the Bidder.

GI09 REVISION OF BID

- 1) A bid submitted in accordance with these instructions may be revised by letter or facsimile provided the revision is received at the office designated for the receipt of bids, on or before the date and time set for the closing of the solicitation. The letter or facsimile shall be on the Bidder's letterhead or bear a signature that identifies the Bidder;
- 2) A revision to a bid that includes unit prices must clearly identify the changes(s) in the unit price(s) and the specific item(s) to which each change applies.
- 3) A letter or facsimile submitted to confirm an earlier revision shall be clearly identified as a confirmation.
- 4) Failure to comply with any of the above provisions shall result in the rejection of the non-compliant revision(s) only. The bid shall be evaluated based on the original bid submitted and all other compliant revision(s).

GI10 REJECTION OF BID

- 1) Canada may accept any bid, whether it is the lowest or not, or may reject any or all bids.
- 2) Without limiting the generality of paragraph 1) of GI10, Canada may reject a bid if any of the following circumstances is present:

GENERAL INSTRUCTIONS TO BIDDERS (Continued)

- (a) the Bidder, or any employee or subcontractor included as part of the bid, has been convicted under Section 121 ("Frauds on the government" & "Contractor subscribing to election fund"), 124 "Selling or purchasing office"), 380 ("Fraud committed against Her Majesty") or 418 ("Selling defective stores to Her Majesty") of the Criminal Code of Canada, or under paragraph 80(1)(d) ("False entry, certificate or return"), subsection 80(2) ("Fraud against Her Majesty") or Section 154.01 ("Fraud against Her Majesty") of the *Financial Administration Act*;
 - (b) the Bidder's bidding privileges are suspended or are in the process of being suspended;
 - (c) the bidding privileges of any employee or subcontractor included as part of the bid are suspended or are in the process of being suspended, which suspension or pending suspension would render that employee or subcontractor ineligible to bid on the Work, or the portion of the Work the employee or subcontractor is to perform;
 - (d) the Bidder is bankrupt, or where for whatever reason, its activities are rendered inoperable for an extended period;
 - (e) evidence, satisfactory to Canada, of fraud, bribery, fraudulent misrepresentation or failure to comply with any law protecting individuals against any manner of discrimination, has been received with respect to the Bidder, any of its employees or any subcontractor included as part of its bid;
 - (f) evidence satisfactory to Canada that based on past conduct or behavior, the Bidder, a sub-contractor or a person who is to perform the Work is unsuitable or has conducted himself/herself improperly;
 - (g) with respect to current or prior transactions with Canada
 - (i) Canada has exercised, or intends to exercise, the contractual remedy of taking the work out of the contractor's hands with respect to a contract with the Bidder, any of its employees or any subcontractor included as part of its bid; or
 - (ii) Canada determines that the Bidder's performance on other contracts is sufficiently poor to jeopardize the successful completion of the requirement being bid on.
- 3) In assessing the Bidder's performance on other contracts pursuant to subparagraph 2)(g)(ii) of GI10, Canada may consider, but not be limited to, such matters as:
- (a) the quality of workmanship in performing the Work;
 - (b) the timeliness of completion of the Work;
 - (c) the overall management of the Work and its effect on the level of effort demanded of the department and its representative; and
 - (d) the completeness and effectiveness of the Contractor's safety program during the performance of the Work.
- 4) Without limiting the generality of paragraphs 1), 2) and 3) of GI10, Canada may reject any bid based on an unfavourable assessment of the:
- (a) adequacy of the bid price to permit the work to be carried out and, in the case of a bid

GENERAL INSTRUCTIONS TO BIDDERS (Continued)

providing prices per unit or a combination of lump sum and prices per unit, whether each such price reasonably reflects the cost of performing the part of the work to which that price applies;

- (b) Bidder's ability to provide the necessary management structure, skilled personnel, experience and equipment to perform competently the work under the Contract; and
 - (c) Bidder's performance on other contracts.
- 5) Where Canada intends to reject a bid pursuant to a provision of paragraphs 1), 2), 3) or 4) of GI10, other than subparagraph 2)(g) of IT10, the contracting authority will inform the Bidder and provide the Bidder ten (10) days within which to make representations, before making a final decision on the bid rejection.
- 6) Canada may waive informalities and minor irregularities in bids received if Canada determines that the variation of the bid from the exact requirements set out in the Bid Documents can be corrected or waived without being prejudicial to other Bidders.

GI11 BID COSTS

- 1) No payment will be made for costs incurred in the preparation and submission of a bid in response to the bid solicitation. Costs associated with preparing and submitting a bid, as well as any costs incurred by the Bidder associated with the evaluation of the bid, are the sole responsibility of the Bidder.

GI12 COMPLIANCE WITH APPLICABLE LAWS

- 1) By submission of a bid, the Bidder certifies that the Bidder has the legal capacity to enter into a contract and is in possession of all valid licences, permits, registrations, certificates, declarations, filings, or other authorizations necessary to comply with all federal, provincial and municipal laws and regulations applicable to the submission of the bid and entry into any ensuing contract for the performance of the work.
- 2) For the purpose of validating the certification in paragraph 1) of GI12, a Bidder shall, if requested, provide a copy of every valid licence, permit, registration, certificate, declaration, filing or other authorization listed in the request, and shall provide such documentation within the time limit(s) set out in the said request.
- 3) Failure to comply with the requirements of paragraph 2) of GI12 shall result in disqualification of the bid.

GI13 APPROVAL OF ALTERNATIVE MATERIALS

- 1) When materials are specified by trade names or trademarks, or by manufacturers' or suppliers' names, the bid shall be based on use of the named materials. During the solicitation period, alternative materials may be considered provided full technical data is received in writing by the Contracting Officer at least 10 calendar days prior to the solicitation closing date.

GI14 CONFLICT OF INTEREST - UNFAIR ADVANTAGE

- 1) In order to protect the integrity of the procurement process, bidders are advised that Canada may reject a bid in the following circumstances:

GENERAL INSTRUCTIONS TO BIDDERS (Continued)

- (a) if the Bidder, any of its subcontractors, any of their respective employees or former employees was involved in any manner in the preparation of the bid solicitation or in any situation of conflict of interest or appearance of conflict of interest;
 - (b) if the Bidder, any of its subcontractors, any of their respective employees or former employees had access to information related to the bid solicitation that was not available to other bidders and that would, in Canada's opinion, give or appear to give the Bidder an unfair advantage.
- 2) The experience acquired by a bidder who is providing or has provided the goods and services described in the bid solicitation (or similar goods or services) will not, in itself, be considered by Canada as conferring an unfair advantage or creating a conflict of interest. This bidder remains however subject to the criteria established above.
- 3) Where Canada intends to reject a bid under this section, the Contracting Authority will inform the Bidder and provide the Bidder an opportunity to make representations before making a final decision. Bidders who are in doubt about a particular situation should contact the Contracting Authority before bid closing. By submitting a bid, the Bidder represents that it does not consider itself to be in conflict of interest nor to have an unfair advantage. The Bidder acknowledges that it is within Canada's sole discretion to determine whether a conflict of interest, unfair advantage or an appearance of conflict of interest or unfair advantage exists.



INSURANCE TERMS

IN1 GENERAL

- IN1.1 Worker's Compensation
- IN1.2 Indemnification
- IN1.3 Proof of Insurance
- IN1.4 Insured
- IN1.5 Payment of Deductible

IN2 COMMERCIAL GENERAL LIABILITY

- IN2.1 Scope of Policy
- IN2.2 Period of Insurance

IN3 AUTOMOBILE INSURANCE

- IN3.1 Scope of Policy

IN4 BUILDER'S RISK / INSTALLATION FLOATER

- IN4.1 Scope of Policy
- IN4.2 Amount of Insurance
- IN4.3 Period of Insurance
- IN4.4 Insurance Proceeds

IN1 GENERAL

IN1.1 Worker's Compensation

- 1) The Contractor shall provide and maintain Worker's Compensation Insurance in accordance with the legal requirements of the Province or Territory where the work is being carried out.

IN1.2 Indemnification

- 1) The insurance required by the provisions of these Insurance Terms shall in no way limit the Contractor's responsibility under the Indemnification clause of the General Conditions of the contract. Any additional coverage the Contractor may deem necessary to fulfill his obligations under the aforesaid clause shall be at his own discretion and expense.

IN1.3 Proof of Insurance

- 1) Before commencement of the Work, and within thirty (30) days after acceptance of its bid, the Contractor shall deposit with Canada a CERTIFICATE OF INSURANCE (form AAFC / AAC5314) available upon request.
- 2) Upon request by Canada, the Contractor shall provide originals or certified true copies of all contracts of insurance maintained by the Contractor pursuant to the provisions contained herein.

IN1.4 Insured

- 1) Each policy shall insure the Contractor and shall include Her Majesty the Queen in right of Canada, represented by the Minister of Agriculture & Agri-Food Canada as an additional Insured, with respect to liability arising out of the operations of the contractor with regard to the work.

INSURANCE TERMS (Continued)

IN1.5 Payment of Deductible

- 1) The payment of monies up to the deductible amount made in satisfaction of a claim shall be borne by the Contractor.

IN2 COMMERCIAL GENERAL LIABILITY

IN2.1 Scope of Policy

- 1) The insurance coverage provided shall not be less than that provided by IBC Form 2100, as amended from time to time, and shall have:
 - (a) an Each Occurrence Limit of not less than \$5,000,000.00 ;
 - (b) a Products/Completed Operations Aggregate Limit of not less than \$5,000,000.00 ; and
 - (c) a General Aggregate Limit of not less than \$10,000,000.00 per policy year, if the policy is subject to such a limit.
- 2) The policy shall either include or be endorsed to include coverage for the following exposures or hazards if the Work is subject thereto:
 - (a) Blasting.
 - (b) Pile driving and caisson work.
 - (c) Underpinning.
 - (d) Removal or weakening of support of any building or land whether such support be natural or otherwise if the work is performed by the insured contractor.
 - (e) Asbestos.
 - (f) Non-owed Automobile Policy.

IN2.2 Period of Insurance

- 1) Unless otherwise directed in writing by Canada, or, otherwise stipulated elsewhere herein, the policy required herein shall be in force and be maintained from the date of contract award until the day of issue of the Certificate of Completion except that the coverage for Completed Operations Liability shall, in any event, be maintained for a period of at least six (6) years beyond the date of the CERTIFICATE OF SUBSTANTIAL PERFORMANCE.

IN3 AUTOMOBILE INSURANCE

IN3.1 Scope of Policy

- 1) Automobile Liability Insurance in respect of licensed vehicles shall have limits of not less than one million dollars inclusive per occurrence for bodily injury, death, and damage to property.

INSURANCE TERMS (Continued)

IN4 BUILDER'S RISK / INSTALLATION FLOATER

IN4.1 Scope of Policy

- 1) The insurance coverage provided by a Builder's Risk policy or an Installation Floater policy shall not be less than that provided by IBC Forms 4042 and 4047, as amended from time to time.
- 2) The policy shall permit use and occupancy of the project, or any part thereof, where such use and occupancy is for the purposes for which the project is intended upon completion.
- 3) The policy may exclude or be endorsed to exclude coverage for loss or damage caused by any of the following:
 - (a) Asbestos.
 - (b) Fungi or spores.
 - (c) Cyber.
 - (d) Terrorism.

IN4.2 Amount of Insurance

- 1) The amount of insurance shall not be less than the sum of the contract value plus the declared value (if any) set forth in the contract documents of all material and equipment supplied by Canada at the site of the project to be incorporated into and form part of the finished Work. If the value of the Work is changed, the policy shall be changed to reflect the revised contract value.

IN4.3 Period of Insurance

- 1) Unless otherwise directed in writing by Canada, or, stipulated elsewhere herein, the policy required herein shall be in force and be maintained from prior to the commencement of work until the day of issue of the CERTIFICATE OF SUBSTANTIAL PERFORMANCE.

IN4.4 Insurance Proceeds

- 1) The policy shall provide that the proceeds thereof are payable to Her Majesty or as Canada may direct in accordance with GC 10.2 Insurance Proceeds.
- 2) The Contractor shall, without delay, do such things and execute such documents as are necessary to effect payment of the proceeds.



BID AND ACCEPTANCE FORM CONSTRUCTION CONTRACT - MAJOR WORKS

BA01 IDENTIFICATION					
Description of the Work Roof Replacement, building 22					
Solicitation Number 14-1054			File / Project Number MCE14-529452		
BA02 BUSINESS NAME AND ADDRESS OF BIDDER					
Name					
Address					
Unit/Suite/Apt.	Street number	Number suffix	Street name	Street type	Street direction
PO Box or Route Number		Municipality (City, Town, etc.)		Province	Postal code
Phone number		Fax number		Email address	
BA03 THE OFFER					
1) The Bidder offers to Canada as represented by the Minister of Agriculture and Agri-food Canada to perform and complete the Work for the above named project in accordance with the Bid Documents for the Total Bid Amount of: \$ _____ excluding Applicable Taxes (GST/HST/QST). (to be expressed in numbers only)					
BA04 BID VALIDITY PERIOD					
1) The bid shall not be withdrawn for a period of <u>30</u> days following the date of solicitation closing.					
BA05 APPENDICES					
1) The following appendices are included in this Bid and Acceptance Form: <input checked="" type="checkbox"/> No appendices					
BA06 ACCEPTANCE AND CONTRACT					
1) Upon acceptance of the Bidder's offer by Canada, a binding Contract shall be formed between Canada and the resulting Contractor. The documents forming the Contract shall be the contract documents referred to in SC01 CONTRACT DOCUMENTS.					
BA07 CONSTRUCTION TIME					
1) The Contractor shall perform and complete the Work within <u>10</u> weeks from the date of notification of acceptance of the offer.					
BA08 BID SECURITY					
1) The Bidder shall enclose bid security with its bid in accordance with GI07 BID SECURITY REQUIREMENTS.					
2) If a security deposit is furnished as bid security, it shall be forfeited in the event that the bid is accepted by Canada and the Contractor fails to provide Contract Security in accordance with GC9 CONTRACT SECURITY, provided that Canada may, if it is in the public interest, waive the right of Canada to forfeiture any or all of the security deposit.					

BA09 SIGNATURE

Name and title of person authorized
to sign on behalf of Bidder
(type or print)

Name

Title

Signature

Date

Name

Title

Signature

Date



MAJOR WORKS – GENERAL CONDITIONS

Page 1 of 54

MAJOR WORKS GENERAL CONDITIONS FORM AAFC 5321:

Revision Date

GC1	GENERAL PROVISIONS	Original
GC2	ADMINISTRATION OF THE CONTRACT	Original
GC3	EXECUTION AND CONTROL OF THE WORK	Original
GC4	PROTECTIVE MEASURES	Original
GC5	TERMS OF PAYMENT	Original
GC6	DELAYS AND CHANGES IN THE WORK	Original
GC7	DEFAULT, SUSPENSION OR TERMINATION OF CONTRACT	Original
GC8	DISPUTE RESOLUTION	Original
GC9	CONTRACT SECURITY	Original
GC10	INSURANCE	Original

GC1 GENERAL PROVISIONS

- GC1.1 INTERPRETATION
 - GC1.1.1 Headings and References
 - GC1.1.2 Terminology
 - GC1.1.3 Application of Certain Provisions
 - GC1.1.4 Substantial Performance
 - GC1.1.5 Completion
- GC1.2 CONTRACT DOCUMENTS
 - GC1.2.1 General
 - GC1.2.2 Order of Precedence
 - GC1.2.3 Security and Protection of Documents and Work
- GC1.3 STATUS OF THE CONTRACTOR
- GC1.4 RIGHTS AND REMEDIES
- GC1.5 TIME OF THE ESSENCE
- GC1.6 INDEMNIFICATION BY THE CONTRACTOR
- GC1.7 INDEMNIFICATION BY CANADA
- GC1.8 LAWS, PERMITS AND TAXES
- GC1.9 WORKERS' COMPENSATION
- GC1.10 NATIONAL SECURITY
- GC1.11 UNSUITABLE WORKERS
- GC1.12 PUBLIC CEREMONIES AND SIGNS
- GC1.13 CONFLICT OF INTEREST
- GC1.14 AGREEMENTS AND AMENDMENTS
- GC1.15 SUCCESSION
- GC1.16 ASSIGNMENT
- GC1.17 NO BRIBE
- GC1.18 CERTIFICATION - CONTINGENCY FEES
- GC1.19 INTERNATIONAL SANCTIONS

GC1.1 INTERPRETATION

GC1.1.1 Headings and References

- 1) The headings in the contract documents, other than those in the drawings and specifications, form no part of the Contract but are inserted for convenience of reference only.
- 2) A reference made to a part of the Contract by means of numbers preceded by letters is a reference to the particular part of the Contract that is identified by that combination of letters and numbers and to any other part of the Contract referred to therein.
- 3) A reference to a paragraph or subparagraph followed by an identifying number, letter or combination thereof is, unless specifically stated otherwise, a reference to the paragraph or subparagraph that forms part of the clause within which the reference is made.

GC1.1.2 Terminology

- 1) In the Contract

"Applicable Taxes" means the Goods and Services Tax (GST), the Harmonized Sales Tax (HST), and any provincial tax, by law, payable by Canada such as, the Quebec Sales Tax (QST) as of April 1, 2013;

"Canada", "Crown", "Her Majesty" means Her Majesty the Queen in right of Canada;

"Contract" means the contract documents referred to as such therein and every other document specified or referred to in any of them as forming part of the Contract, all as amended by agreement of the parties;

"Contract Amount" means the amount set out in the Contract to be payable to the Contractor for the Work, subject to the terms and conditions of the Contract, exclusive of Applicable Taxes;

"Contract Security" means any security given by the Contractor to Canada in accordance with the Contract;

"Contractor" means the person contracting with Canada to provide or furnish all labour, Material and Plant for the execution of the Work under the Contract, and includes the Contractor's superintendent as designated in writing to Canada.

"Certificate of Completion" means a certificate issued by Canada when the Work reaches Completion;

"Certificate of Measurement" means a certificate issued by Canada certifying the correctness of the final quantities, prices per unit and values of labour, Plant and Material performed, used and supplied by the Contractor for the construction of the part of the Work to which a Unit Price Arrangement applies;

"Certificate of Substantial Performance" means a certificate issued by Canada when the Work reaches Substantial Performance;

"Departmental Representative" means the person designated in the Contract, or by written notice to the Contractor, to act as the Departmental Representative for the purposes of the Contract, and includes a person, designated and authorized in writing by the Departmental Representative to the Contractor;

"herein", "hereby", "hereof", "hereunder" and similar expressions refer to the Contract as a whole and not to any particular section or part thereof;

"Lump Sum Arrangement" means that part of the Contract that prescribes a lump sum as payment for performance of the Work to which it relates;

"Material" includes all commodities, articles, machinery, equipment, fixtures and things required to be furnished in accordance with the Contract for incorporation into the Work;

"person" also includes, unless there is an express stipulation in the Contract to the contrary, any partnership, proprietorship, firm, joint venture, consortium or corporation;

"Plant" includes all tools, implements, machinery, vehicles, structures, equipment, articles and things that are necessary for the performance of the Contract, other than Material and those tools customarily provided by a tradesperson in practicing a trade;

"Subcontractor" means a person having a direct contract with the Contractor, subject to GC3.6 SUBCONTRACTING, to perform a part or parts of the Work, or to supply Material customized for the Work;

"Superintendent" means the employee or representative of the Contractor designated by the Contractor to act pursuant to GC2.6 SUPERINTENDENT;

"Supplementary Conditions" means the part of the Contract that amends or supplements the General Conditions;

"Supplier" means a person having a direct contract with the Contractor to supply Plant or Material not customized for the Work;

"Total Estimated Cost", "Revised Estimated Cost", "Increase (Decrease)" on Page 1 of the Contract or Contract Amendment means an amount used for internal administrative purposes only that comprises the Contract Amount, or the revised Contract Amount, or the amount that would increase or decrease the Contract Amount and the Applicable Taxes as evaluated by the Contracting Authority, and does not constitute tax advice on the part of Canada;

"Unit Price Arrangement" means that part of the Contract that prescribes the product of a price per unit of measurement multiplied by a number of units of measurement for performance of the Work to which it relates;

"Unit Price Table" means the table of prices per unit set out in the Contract;

"Work" means, subject only to any express stipulation in the Contract to the contrary, everything that is necessary to be done, furnished or delivered by the Contractor to perform the Contract in accordance with the contract documents; and

"Working Day" means a day other than a Saturday, Sunday, or a statutory holiday that is observed by the construction industry in the area of the place of the Work.

GC1.1.3 Application of Certain Provisions

- 1) Any provisions of the Contract that are expressly stipulated to be applicable only to a Unit Price Arrangement are not applicable to any part of the Work to which a Lump Sum Arrangement applies.
- 2) Any provisions of the Contract that are expressly stipulated to be applicable only to a Lump Sum Arrangement are not applicable to any part of the Work to which a Unit Price Arrangement applies.

GC1.1.4 Substantial Performance

- 1) The Work shall be considered to have reached Substantial Performance when
 - (a) the Work or a substantial part thereof has passed inspection and testing and is, in the opinion of Canada, ready for use by Canada or is being used for the intended purposes; and
 - (b) the Work is, in the opinion of Canada, capable of completion or correction at a cost of not more than
 - (i) 3 percent of the first \$500,000;
 - (ii) 2 percent of the next \$500,000; and
 - (iii) 1 percent of the balanceof the Contract Amount at the time this cost is calculated.
- 2) Where the Work or a substantial part thereof is ready for use or is being used for the purposes intended and

- (a) the remainder of the Work or a part thereof cannot be completed by the time specified in the Contract, or as amended in accordance with GC6.5 DELAYS AND EXTENSION OF TIME, for reasons beyond the control of the Contractor; or
- (b) Canada and the Contractor agree not to complete a part of the Work within the specified time;

the cost of that part of the Work that was either beyond the control of the Contractor to complete or Canada and the Contractor have agreed not to complete by the time specified, shall be deducted from the value of the Contract referred to in subparagraph 1)(b) of GC1.1.4 and the said cost shall not form part of the cost of the Work remaining to be done in determining Substantial Performance.

GC1.1.5 Completion

- 1) The Work shall be deemed to have reached Completion when all labour, Plant and Material required have been performed, used or supplied, and the Contractor has complied with the Contract and all orders and directions made pursuant thereto, all to the satisfaction of Canada.

GC1.2 CONTRACT DOCUMENTS**GC1.2.1 General**

- 1) The contract documents are complementary, and what is required by any one shall be as binding as if required by all.
- 2) References in the contract documents to the singular shall be considered to include the plural as the context requires.
- 3) Nothing contained in the contract documents shall create a contractual relationship between Canada and any Subcontractor or Supplier, their subcontractors or suppliers, or their agents or employees.

GC1.2.2 Order of Precedence

- 1) In the event of any discrepancy or conflict in the contents of the following documents, such documents shall take precedence and govern in the following order:
 - (a) any amendment or variation of the contract documents that is made in accordance with the General Conditions;
 - (b) any amendment issued prior to tender closing;
 - (c) Supplementary Conditions;
 - (d) General Conditions;
 - (e) the duly completed Bid and Acceptance Form when accepted;
 - (f) drawings and specifications.

later dates shall govern within each of the above categories of documents.

- 2) In the event of any discrepancy or conflict in the information contained in the drawings and specifications, the following rules shall apply:
 - (a) specifications shall govern over drawings;
 - (b) dimensions shown in figures on a drawings shall govern where they differ from dimensions scaled from the same drawings; and
 - (c) drawings of larger scale govern over those of smaller scale.

GC1.2.3 Security and Protection of Documents and Work

- 1) The Contractor shall guard and protect contract documents, drawings, information, models and copies thereof, whether supplied by Canada or the Contractor, against loss or damage from any cause.
- 2) The Contractor shall keep confidential all information provided to the Contractor by or on behalf of Canada in connection with the Work, and all information developed by the Contractor as part of the Work, and shall not disclose any such information to any person without the written permission of Canada, except that the Contractor may disclose to a subcontractor, authorized in accordance with the Contract, information necessary to the performance of a subcontract. This section does not apply to any information that
 - (a) is publicly available from a source other than the Contractor; or
 - (b) is or becomes known to the Contractor from a source other than Canada, except any source that is known to the Contractor to be under an obligation to Canada not to disclose the information.
- 3) When the Contract, the Work, or any information referred to in paragraph 2) is identified as top secret, secret, confidential, or protected by Canada, the Contractor shall, at all times, take all measures reasonably necessary for the safeguarding of the material so identified, including such measures as may be further specified elsewhere in the Contract or provided, in writing, from time to time by Canada.
- 4) Without limiting the generality of paragraphs 2) and 3) of GC1.2.3, when the Contract, the Work, or any information referred to in paragraph 2) is identified as top secret, secret, confidential or protected by Canada, Canada shall be entitled to inspect the Contractor's premises and the premises of its subcontractors or suppliers and any other person at any tier, for security purposes at any time during the term of the Contract, and the Contractor shall comply with, and ensure that any such subcontractors or suppliers comply with all written instructions issued by Canada dealing with the material so identified, including any requirement that employees of the Contractor and its subcontractors and suppliers and any other person at any tier execute and deliver declarations relating to reliability screenings, security clearances and other procedures.
- 5) The Contractor shall safeguard the Work and the Contract, the specifications, drawings and any other information provided by Canada to the Contractor, and shall be liable to Canada for any loss or damage from any causes.

GC1.3 STATUS OF THE CONTRACTOR

- 1) The Contractor is engaged under the Contract as an independent contractor.

- 2) The Contractor, its subcontractors and suppliers and any other person at any tier and their employees are not engaged by the Contract as employees, servants or agents of Canada.
- 3) For the purposes of the contract the Contractor shall be solely responsible for any and all payments and deductions required to be made by law including those required for Canada or Quebec Pension Plans, Employment Insurance, Worker's Compensation, provincial health or insurance plans, and Income Tax.

GC1.4 RIGHTS AND REMEDIES

- 1) Except as expressly provided in the Contract, the duties and obligations imposed by the Contract and the rights and remedies available thereunder shall be in addition to and not a limitation of any duties, obligations, rights, and remedies otherwise imposed or available by law.

GC1.5 TIME OF THE ESSENCE

- 1) Time is of the essence of the Contract.

GC1.6 INDEMNIFICATION BY THE CONTRACTOR

- 1) The Contractor shall pay all royalties and patent fees required for the performance of the Contract and, at the Contractor's expense, shall defend all claims, actions or proceedings against Canada charging or claiming that the Work or any part thereof provided or furnished by the Contractor to Canada infringes any patent, industrial design, copyright trademark, trade secret or other proprietary right enforceable in Canada.
- 2) The Contractor shall indemnify and save Canada harmless from and against all claims, demands, losses, costs, damages, actions, suits, or proceedings by any third party, brought or prosecuted and in any manner based upon, arising out of, related to, occasioned by, or attributable to the activities of the Contractor, its subcontractors and suppliers and any other person at any tier, in performing the Work.
- 3) For the purposes of paragraph 2) of GC1.6, "activities" means any act improperly carried out, any omission to carry out an act and any delay in carrying out an act.

GC1.7 INDEMNIFICATION BY CANADA

- 1) Subject to the [Crown Liability and Proceedings Act](#), the [Patent Act](#), and any other law that affects Canada's rights, powers, privileges or obligations, Canada shall indemnify and save the Contractor harmless from and against all claims, demands, losses, costs, damage, actions, suits or proceedings arising out of the Contractor's activities under the Contract that are directly attributable to
 - (a) a lack of or a defect in Canada's title to the Work site if owned by Canada, whether real or alleged; or
 - (b) an infringement or an alleged infringement by the Contractor of any patent of invention or any other kind of intellectual property occurring while the Contractor was performing any act for the purposes of the Contract employing a model, plan or design or any other thing related to the Work that was supplied by Canada to the Contractor.

GC1.8 LAWS, PERMITS AND TAXES

- 1) The Contractor shall comply with all federal, provincial and municipal laws and regulations applicable to the performance of the Work or any part thereof including, without limitation, all laws concerning health and labour conditions and the protection of the environment, and shall require compliance therewith by all of its subcontractors and suppliers at any tier as if the Work were being performed for an owner other than Canada. The Contractor shall furnish evidence of compliance with such laws and regulations to Canada at such times as Canada may reasonably request.
- 2) Unless stipulated otherwise in the Contract, the Contractor shall obtain and maintain all permits, certificates, licences, registrations and authorizations required for the lawful performance of the Work.
- 3) Prior to the commencement of the Work at the site, the Contractor shall tender to a municipal authority an amount equal to all fees and charges that would be lawfully payable to that municipal authority in respect of building permits as if the Work were being performed for an owner other than Canada.
- 4) Within 10 days of making a tender pursuant to paragraph 3) of GC1.8, the Contractor shall notify Canada of the amount properly tendered and whether or not the municipal authority has accepted that amount.
- 5) If the municipal authority has not accepted the amount tendered, the Contractor shall pay that amount to Canada within 6 days after the time stipulated in paragraph 4) of GC1.8.
- 6) For the purposes of this clause, "municipal authority" means any authority that would have jurisdiction respecting permission to perform the Work if the owner were not Canada.
- 7) Notwithstanding the residency of the Contractor, the Contractor shall pay any applicable tax arising from or related to the performance of the Work under the Contract.
- 8) In accordance with the Statutory Declaration referred to in paragraph 4) of GC5.5 SUBSTANTIAL PERFORMANCE OF THE WORK, a Contractor who has neither residence nor place of business in the province or territory in which work under the Contract is being performed shall provide Canada with proof of registration with the provincial sales tax authorities in the said province.
- 9) For the purpose of the payment of any Applicable Taxes or the furnishing of security for the payment of any Applicable Taxes arising from or related to the performance of the Work, and notwithstanding the provision that all Material, Plant and interest of the Contractor in all real property, licences, powers and privileges, become the property of Canada after the time of purchase in accordance with GC3.10 MATERIAL PLANT AND REAL PROPERTY BECOME PROPERTY OF CANADA, the Contractor shall be liable, as a user or consumer, for the payment or for the furnishing of security for the payment of any Applicable Taxes payable, at the time of the use or consumption of that Material, Plant or interest of the Contractor in accordance with the relevant legislation.
- 10) Federal government departments and agencies are required to pay Applicable Taxes.
- 11) Applicable Taxes will be paid by Canada as provided in the request for payment. It is the sole responsibility of the Contractor to charge Applicable Taxes at the correct rate in accordance with applicable legislation. The Contractor agrees to remit to appropriate tax authorities any amounts of Applicable Taxes paid or due.

- 12) The Contractor is not entitled to use Canada's exemptions from any tax, such as provincial sales taxes, unless otherwise specified by law. The Contractor must pay applicable provincial sales tax, ancillary taxes, and any commodity tax, on taxable goods or services used or consumed in the performance of the Contract (in accordance with applicable legislation), including for material incorporated into real property.
- 13) In those cases where Applicable Taxes, customs duties, and excise taxes are included in the Contract Amount, the Contract Amount will be adjusted to reflect any increase, or decrease, of Applicable Taxes, customs duties, and excise taxes that will have occurred between bid submission and contract award. However, there will be no adjustment for any change to increase the Contract Amount if public notice of the change was given before bid submission date in sufficient detail to have permitted the Contractor to calculate the effect of the change.
- 14) Tax Withholding of 15 Percent – Canada Revenue Agency

Pursuant to the [Income Tax Act](#), 1985, c. 1 (5th Supp.) and the [Income Tax Regulations](#), Canada must withhold 15 percent of the amount to be paid to the Contractor in respect of services provided in Canada if the Contractor is not a resident of Canada, unless the Contractor obtains a valid waiver from the Canada Revenue Agency. The amount withheld will be held on account for the Contractor in respect to any tax liability which may be owed to Canada.

GC1.9 WORKERS' COMPENSATION

- 1) Prior to commencement of Work, at the time of Substantial Performance of the Work, and prior to issuance of the Certificate of Completion, the Contractor shall provide evidence of compliance with workers' compensation legislation applicable to the place of the Work, including payments due thereunder.
- 2) At any time during the term of the Contract, when requested by Canada, the Contractor shall provide such evidence of compliance by the Contractor, its subcontractors and any other person at any tier and any other person performing part of the Work who is required to comply with such legislation.

GC1.10 NATIONAL SECURITY

- 1) If Canada determines that the Work is of a class or kind that involves national security, Canada may order the Contractor to
 - (a) provide Canada with any information concerning persons employed or to be employed by the Contractor for purposes of the Contract; and
 - (b) remove any person from the site of the Work if, in the opinion of Canada, that person may be a risk to the national security;and the Contractor shall comply with the order.
- 2) In all contracts with persons who are to be employed in the performance of the Contract, the Contractor shall make provision for the performance of any obligation that may be imposed upon the Contractor under paragraph 1) of GC1.10.

GC1.11 UNSUITABLE WORKERS

- 1) Canada shall instruct the Contractor to remove from the site of the Work any person employed by the Contractor for purposes of the Contract who, in the opinion of Canada, is incompetent or is guilty of improper conduct, and the Contractor shall not permit a person who has been removed to return to the site of the Work.

GC1.12 PUBLIC CEREMONIES AND SIGNS

- 1) The Contractor shall not permit any public ceremony in connection with the Work without the prior consent of Canada.
- 2) The Contractor shall not erect nor permit the erection of any sign or advertising on the Work or its site without the prior consent of Canada.

GC1.13 CONFLICT OF INTEREST

- 1) It is a term of the Contract that no individual, for whom the post-employment provisions of the Conflict of Interest and Post-Employment Code for Public Office Holders or the Values and Ethics Code for the Public Service apply, shall derive a direct benefit from the Contract unless that individual is in compliance with the applicable post-employment provisions.

GC1.14 AGREEMENTS AND AMENDMENTS

- 1) The Contract constitutes the entire and sole agreement between the parties with respect to the subject matter of the Contract and supersedes all previous negotiations, communications and other agreements, whether written or oral, relating to it, unless they are incorporated by reference in the Contract. There are no terms, covenants, representations, statements or conditions binding on the parties other than those contained in the Contract.
- 2) The failure of either party at any time to require performance by the other party of any provision hereof shall not affect the right thereafter to enforce such provision. Nor shall the waiver by either party of any breach of any covenant, term or condition hereof be taken to be held to be a waiver of any further breach of the same covenant, term or condition.
- 3) The Contract may be amended only as provided for in the Contract.

GC1.15 SUCCESSION

- 1) The Contract shall inure to the benefit of and be binding upon the parties hereto and their lawful heirs, executors, administrators, successors and, subject to GC1.16 ASSIGNMENT, permitted assigns.

GC1.16 ASSIGNMENT

- 1) The Contractor shall not make any assignment of the Contract, either in whole or in part, without the written consent of Canada.

GC1.17 NO BRIBE

- 1) The Contractor represents and covenants that no bribe, gift, benefit, nor other inducement has been nor shall be paid, given, promised or offered directly or indirectly to any official or employee of Canada or to a member of the family of such a person, with a view to influencing the entry into the Contract or the administration of the Contract.

GC1.18 CERTIFICATION - CONTINGENCY FEES

- 1) In this clause
 - (a) "contingency fee" means any payment or other compensation that is contingent upon or is calculated upon the basis of a degree of success in soliciting or obtaining a Government contract or negotiating the whole or any part of its terms;
 - (b) "employee" means a person with whom the Contractor has an employer/employee relationship; and
 - (c) "person" includes an individual or a group of individuals, a corporation, a partnership, an organization and an association and, without restricting the generality of the foregoing, includes any individual who is required to file a return with the registrar pursuant to section 5 of the [Lobbying Act](#) R.S.C. 1985 c.44 (4th Supplement) as the same may be amended from time to time.
- 2) The Contractor certifies that it has not directly or indirectly paid nor agreed to pay and covenants that it shall not directly or indirectly pay nor agree to pay a contingency fee for the solicitation, negotiation or obtaining of the Contract to any person other than an employee acting in the normal course of the employee's duties.
- 3) All accounts and records pertaining to payments of fees or other compensation for the solicitation, obtaining or negotiation of the Contract shall be subject to the accounts and audit provisions of the Contract.
- 4) If the Contractor certifies falsely under this section or is in default of the obligations contained therein, Canada may either take the Work out of the Contractor's hands in accordance with the provisions of the Contract or recover from the Contractor by way of reduction to the Contract Amount or otherwise, the full amount of the contingency fee.

GC1.19 INTERNATIONAL SANCTIONS

- 1) Persons and companies in Canada, and Canadians outside of Canada are bound by economic sanctions imposed by Canada. As a result, the Government of Canada cannot accept delivery of goods or services that originate, either directly or indirectly, from the countries or persons subject to [economic sanctions](#)
- 2) It is a condition of the Contract that the Contractor not supply to the Government of Canada any goods or services which are subject to economic sanctions.
- 3) By law, the Contractor must comply with changes to the regulations imposed during the life of the Contract. During the performance of the Contract should the imposition of sanctions against a country or person or the addition of a good or service to the list of sanctioned goods or services cause an impossibility of performance for the Contractor, the Contractor may request that the Contract be terminated in accordance with GC7.3 TERMINATION OF CONTRACT.

GC2 ADMINISTRATION OF THE CONTRACT

- GC2.1 DEPARTMENTAL REPRESENTATIVE'S AUTHORITY
- GC2.2 INTERPRETATION OF CONTRACT
- GC2.3 NOTICES
- GC2.4 SITE MEETINGS
- GC2.5 REVIEW AND INSPECTION OF WORK
- GC2.6 SUPERINTENDENT
- GC2.7 NON-DISCRIMINATION IN HIRING AND EMPLOYMENT OF LABOUR
- GC2.8 ACCOUNTS AND AUDITS

GC2.1 DEPARTMENTAL REPRESENTATIVE'S AUTHORITY

- 1) Canada shall designate a Departmental Representative and shall notify the Contractor of the name, address and telephone number of the Departmental Representative.
- 2) The Departmental Representative shall perform Canada's duties and functions under the contract.
- 3) The Departmental Representative shall be authorized to issue notices, instructions and directions to the Contractor and to accept on behalf of Canada any notice, order or other communication from the contractor relating to the Work.
- 4) The Departmental Representative shall, within a reasonable time, review and respond to submissions made by the Contractor in accordance with the requirements of the Contract.

GC2.2 INTERPRETATION OF CONTRACT

- 1) If, at any time before Canada has issued a Certificate of Completion, any question arises between the parties about whether anything has been done as required by the Contract or about what the Contractor is required by the Contract to do, and in particular but without limiting the generality of the foregoing, about
 - (a) the meaning of anything in the drawings and specifications;
 - (b) the meaning to be given to the drawings and specifications in case of any error therein, omission therefrom, or obscurity or discrepancy in their wording or intention;
 - (c) whether or not the quality or quantity of any Material or workmanship supplied or proposed to be supplied by the Contractor meets the requirements of the Contract;
 - (d) whether or not the labour, Plant or Material performed, used and supplied by the Contractor for performing the Work and carrying out the Contract are adequate to ensure that the Work shall be performed in accordance with the Contract and that the Contract shall be carried out in accordance with its terms;
 - (e) what quantity of any of the Work has been completed by the Contractor; or
 - (f) the timing and scheduling of the various phases of the performance of the Work as specified in the Contract;

the question shall be decided, subject to the provisions of GC8 DISPUTE RESOLUTION, by Canada.

- 2) The Contractor shall perform the Work in accordance with any decisions of Canada that are made under paragraph 1) of GC2.2 and in accordance with any consequential directions given by Canada.
- 3) If the Contractor fails to comply with any instruction or direction issued by Canada pursuant to the Contract, Canada may employ such methods as Canada deems advisable to do what the Contractor failed to do, and the Contractor shall, on demand, pay Canada an amount that is equal to the aggregate of all costs, expenses and damages incurred or sustained by Canada by reason of the Contractor's failure to comply with such instruction or direction, including the cost of any methods employed by Canada in doing what the Contractor failed to do.

GC2.3 NOTICES

- 1) Subject to paragraph 3) of GC2.3, any notice, order or other communication may be given in any manner, and if required to be in writing, shall be addressed to the party to whom it is intended at the address in the Contract or at the last address of which the sender has received written notice in accordance with this section.
- 2) Any notice, order or other communication given in writing in accordance with paragraph 1) of GC2.3 shall be deemed to have been received by either party
 - (a) if delivered personally, on the day that it was delivered;
 - (b) if forwarded by mail, on the earlier of the day it was received or the sixth day after it was mailed; and
 - (c) if forwarded by facsimile or electronic mail, 24 hours after it was transmitted.
- 3) A notice given under GC7.1 TAKING THE WORK OUT OF THE CONTRACTOR'S HANDS, GC7.2 SUSPENSION OF WORK, and GC7.3 TERMINATION OF CONTRACT shall be given in writing and, if delivered personally, shall be delivered, if the Contractor is a sole proprietor, to the Contractor or, if the Contractor is a partnership or corporation, to an officer thereof.

GC2.4 SITE MEETINGS

- 1) In consultation with Canada, the Contractor shall arrange site meetings at regular intervals, with all involved parties who are to attend, in order to ensure, among other things, the proper co-ordination of the Work.

GC2.5 REVIEW AND INSPECTION OF WORK

- 1) Canada shall review the Work to determine if it is proceeding in conformity with the Contract and to record the necessary data to make an assessment of the value of Work completed. Canada shall measure and record the quantities of labour, Plant and Material performed, used or supplied by the Contractor in performing the Work or any part thereof that is subject to a Unit Price Arrangement and, on request, shall inform the Contractor of those measurements, and permit the Contractor to inspect any records pertaining thereto.
- 2) Canada shall reject Work or Material which in Canada's opinion does not conform to the requirements of the Contract, and shall require inspection or testing of Work, whether or not such Work is fabricated, installed, or completed. If such Work is not in accordance with the

requirements of the Contract, the Contractor shall correct the Work and shall pay Canada, on demand, all reasonable costs and expenses that were incurred by Canada in having the examination performed.

- 3) The Contractor shall provide Canada with access to the Work and its site at all times, and at all times shall provide sufficient, safe, and proper facilities for the review and inspection of the Work by persons authorized by Canada and any representatives of those authorities having jurisdiction. If parts of the Work are in preparation at locations other than the site of the Work, Canada shall be given access to such Work whenever it is in progress.
- 4) The Contractor shall furnish Canada with such information respecting the performance of the Contract as Canada may require, and render every possible assistance to enable Canada to verify that the Work is performed in accordance with the Contract, carry out any other duties and exercise any powers in accordance with the Contract.
- 5) If Work is designated for tests, inspections, or approvals in the Contract or by Canada's instructions, or by laws or ordinances of the place of the Work, the Contractor shall give Canada reasonable notice of when such Work shall be ready for review and inspection. The Contractor shall arrange for and shall give Canada reasonable notice of the date and time of inspections, tests or approvals.
- 6) If the Contractor covers, or permits to be covered, Work that has been designated for tests, inspections or approvals before such tests, inspections or approvals are made, completed or given, the Contractor shall, if so directed by Canada, uncover such Work, have the inspections, tests or approvals satisfactorily made, completed or given and make good the covering of the Work at the Contractor's expense.

GC2.6 SUPERINTENDENT

- 1) Prior to commencing the Work, the Contractor shall designate a Superintendent and shall notify Canada of the name, address and telephone number of the Superintendent. The Contractor shall keep the Superintendent at the Work site during working hours until the Work has reached completion.
- 2) The Superintendent shall be in full charge of the operations of the Contractor during the performance of the Work and shall be authorized to accept on behalf of the Contractor any notice, order or other communication given to the Superintendent or the Contractor relating to the Work.
- 3) Upon request of Canada, the Contractor shall remove any Superintendent who, in the opinion of Canada, is incompetent or has been guilty of improper conduct, and shall forthwith designate another Superintendent who is acceptable to Canada.
- 4) The Contractor shall not substitute a Superintendent without the written consent of Canada. If a Superintendent is substituted without such consent, Canada shall be entitled to refuse to issue any documentation or certification relating to progress payments, Substantial Performance or Completion of the Work until the Superintendent has returned to the Work site or another Superintendent who is acceptable to Canada has been substituted.

GC2.7 NON-DISCRIMINATION IN HIRING AND EMPLOYMENT OF LABOUR

- 1) For the purposes of this clause, "persons" include the Contractor, its subcontractors and suppliers at any tier and their respective employees, agents, licensees or invitees and any other individual involved in the performance of the Work or granted access to the Work site.

A “person” includes any partnership, proprietorship, firm, joint venture, consortium and corporation.

- 2) Without restricting the provisions of paragraph 3) of GC2.6, SUPERINTENDENT, the Contractor shall not refuse to employ and shall not discriminate in any manner against any person because
 - (a) of that person's race, national or ethnic origin, colour, religion, age, sex, sexual orientation, marital status, disability, conviction for which a pardon has been granted, or family status;
 - (b) of the race, national or ethnic origin, colour, religion, age, sex, sexual orientation, marital status, disability, conviction for which a pardon has been granted, or family status of any person having a relationship or association with that person, or
 - (c) a complaint has been made or information has been given in respect of that person relating to an alleged failure by the Contractor to comply with subparagraph (a) or (b).
- 3) Within two working days immediately following receipt of a written complaint pursuant to paragraph 2) of GC2.7, the Contractor shall
 - (a) cause to have issued a written direction to the person or persons named by the complainant to cease all actions that form the basis of the complaint;
 - (b) forward a copy of the complaint to Canada by registered mail or courier service; and
 - (c) when the Labour Conditions are applicable under the circumstances of the complaint, forward a copy of the complaint to HRSDC - Labour to the attention of the appropriate Director as described in the Labour Conditions (“HRSDC - Labour” means the labour component of the federal Department of Human Resources and Social Development).
- 4) Within twenty four (24) hours immediately following receipt of a direction from Canada to do so, the Contractor shall cause to have removed from the site of the Work and from the performance of Work under the Contract, any person or persons whom Canada believes to be in breach of the provisions of paragraph 2) of GC2.7.
- 5) No later than thirty (30) days after receipt of the direction referred to in paragraph 4) of GC2.7, the Contractor shall cause the necessary action to be commenced to remedy the breach described in the direction.
- 6) If a direction is issued pursuant to paragraph 4) of GC2.7, Canada may withhold from monies that are due and payable to the Contractor or setoff pursuant to GC5.9 RIGHT OF SETOFF, whichever is applicable, an amount representing the sum of the costs and payment referred to in paragraph 8) of GC2.7.
- 7) If the Contractor fails to proceed in accordance with paragraph 5) of GC2.7, Canada shall take the necessary action to have the breach remedied, and shall determine all supplementary costs incurred by Canada as a result.
- 8) Canada may make a payment directly to the complainant from monies that are due and payable to the Contractor upon receipt from the complainant of
 - (a) a written award issued pursuant to the federal [Commercial Arbitration Act](#), R.S.C. 1985, c. 17 (2nd Supp.);

- (b) a written award issued pursuant to the Canadian Human Rights Act, R.S.C. 1985, c. H-6;
 - (c) a written award issued pursuant to provincial or territorial human rights legislation; or
 - (d) a judgement issued by a court of competent jurisdiction.
- 9) If Canada is of the opinion that the Contractor has breached any of the provisions of this clause, Canada may take the Work out of the Contractor's hands pursuant to GC7.1 TAKING THE WORK OUT OF THE CONTRACTOR'S HANDS.
- 10) Subject to paragraph 7) of GC3.6 SUBCONTRACTING, the Contractor shall ensure that the provisions of this clause are included in all agreements and contracts entered into as a consequence of the Work.

GC2.8 ACCOUNTS AND AUDITS

- 1) The Contractor shall, in addition to the requirements expressed in paragraph 6) of GC3.4 EXECUTION OF THE WORK, maintain full records of the Contractor's estimated and actual cost of the Work together with all tender calls, quotations, contracts, correspondence, invoices, receipts and vouchers relating thereto, and shall make them available on request to audit and inspection by Canada and the Deputy Receiver General for Canada or by persons designated to act on behalf of either or both of them.
- 2) The Contractor shall allow any of the persons referred to in paragraph 1) of GC2.8 to make copies of and take extracts from any of the records and material, and shall furnish such persons or entities with any information those persons or entities may require from time to time in connection with such records and material.
- 3) The Contractor shall maintain and keep the records intact until the expiration of two years after the date that a Certificate of Completion has been issued or until the expiration of such other period of time as Canada may direct.
- 4) The Contractor shall cause all subcontractors at any tier and all other persons directly or indirectly controlled by or affiliated with the Contractor and all persons directly or indirectly having control of the Contractor to comply with the requirements of this clause as if they were the Contractor.

GC3 EXECUTION AND CONTROL OF THE WORK

- GC3.1 PROGRESS SCHEDULE
- GC3.2 ERRORS AND OMISSIONS
- GC3.3 CONSTRUCTION SAFETY
- GC3.4 EXECUTION OF THE WORK
- GC3.5 MATERIAL
- GC3.6 SUBCONTRACTING
- GC3.7 CONSTRUCTION BY OTHER CONTRACTORS OR WORKERS
- GC3.8 LABOUR
- GC3.9 TRUCK HAULAGE RATES (CANCELLED)
- GC3.10 MATERIAL, PLANT AND REAL PROPERTY BECOME PROPERTY OF CANADA
- GC3.11 DEFECTIVE WORK
- GC3.12 CLEANUP OF SITE
- GC3.13 WARRANTY AND RECTIFICATION OF DEFECTS IN WORK

GC3.1 PROGRESS SCHEDULE

- 1) The Contractor shall
 - (a) prepare and submit to Canada, prior to the submission of the Contractor's first progress claim, a progress schedule in accordance with the requirements set out in the Contract;
 - (b) monitor the progress of the Work relative to the schedule and update the schedule as stipulated by the contract documents;
 - (c) advise Canada of any revisions to the schedule required as the result of any extension of time for completion of the Contract that was approved by Canada; and
 - (d) prepare and submit to Canada, at the time of issuance of a Certificate of Substantial Performance, an update of any schedule clearly showing a detailed timetable that is acceptable to Canada for the completion of any unfinished Work and the correction of all listed defects.

GC3.2 ERRORS AND OMISSIONS

- 1) The Contractor shall report promptly to Canada any errors, discrepancies, or omissions the Contractor may discover when reviewing the contract documents. In making a review, the Contractor does not assume any responsibility to Canada for the accuracy of the review. The Contractor shall not be liable for damage or costs resulting from such errors, discrepancies, or omissions in the contract documents prepared by or on behalf of Canada that the Contractor did not discover.

GC3.3 CONSTRUCTION SAFETY

- 1) Subject to GC3.7 CONSTRUCTION BY OTHER CONTRACTORS OR WORKERS, the Contractor shall be solely responsible for construction safety at the place of the Work and for initiating, maintaining and supervising all safety precautions and programs in connection with the performance of the Work. In any emergency, the Contractor shall either stop the Work, make changes or order extra work to ensure the safety of life and the protection of the Work and neighbouring property.

- 2) Prior to commencing the Work, the Contractor shall notify the authorities having jurisdiction for construction safety at the site of the Work with respect to the intended commencement of the Work, and shall provide such authority with whatever additional information may be required by that authority.

GC3.4 EXECUTION OF THE WORK

- 1) The Contractor shall perform, use or supply and pay for, all labour, Plant, Material, tools, construction machinery and equipment, water, heat, light, power, transportation and other facilities and services necessary for the performance of the Work in accordance with the Contract.
- 2) The Contractor shall, at all times, perform the Work in a proper, diligent and expeditious manner as is consistent with construction industry standards and in accordance with the progress schedule prepared pursuant to GC3.1 PROGRESS SCHEDULE and shall provide sufficient personnel to fulfil the Contractor's obligations in accordance with that schedule.
- 3) Subject to paragraph 4) of GC3.4, the Contractor shall have complete care, custody and control of the Work and shall direct and supervise the Work so as to ensure compliance with the Contract. The Contractor shall be responsible for construction means, methods, techniques, sequences and procedures and for co-ordinating the various parts of the Work.
- 4) When requested in writing by Canada, the Contractor shall make appropriate alterations in the method, Plant or workforce at any time Canada considers the Contractor's actions to be unsafe or damaging to either the Work, existing facilities, persons at the site of the Work or the environment.
- 5) The Contractor shall have sole responsibility for the design, erection, operation, maintenance and removal of temporary structures and other temporary facilities and for the construction methods used in their erection, operation, maintenance and removal. The Contractor shall engage and pay for registered professional engineering personnel, skilled in the appropriate discipline to perform these functions if required by law or by the Contract, and in all cases when such temporary facilities and their methods of construction are of such a nature that professional engineering skill is required to produce safe and satisfactory results.
- 6) The Contractor shall keep at least one copy of current contract documents, submittals, reports, and records of meetings at the site of the Work, in good order and available to Canada.
- 7) Except for any part of the Work that is necessarily performed away from or off the site of the Work, the Contractor shall confine Plant, storage of Material, and operations of employees to limits indicated by laws, ordinances, permits or the contract documents.

GC3.5 MATERIAL

- 1) Unless otherwise specified in the Contract, all Material incorporated in the Work shall be new.
- 2) Subject to paragraph 3) of GC3.5, if a specified reused, refurbished, or recycled item of Material is not available, the Contractor shall apply to Canada to substitute a similar item for the one specified.
- 3) If Canada agrees that the Contractor's application for substitution of a reused, refurbished or recycled item is warranted, and that the substitute item is of acceptable quality and value to

that specified and is suitable for the intended purpose, Canada may approve the substitution, subject to the following:

- (a) the request for substitution shall be made in writing to Canada and shall be substantiated by information in the form of the manufacturer's literature, samples and other data that may be required by Canada;
- (b) the Contractor shall make the request for substitution in a manner that shall not negatively affect the progress schedule of the Contract and well in advance of the time the item of Material must be ordered;
- (c) substitution of Material shall be permitted only with the prior written approval of Canada, and any substituted items that are supplied or installed without such approval shall be removed from the site of the Work at the expense of the Contractor, and specified items installed at no additional cost to Canada; and
- (d) the Contractor shall be responsible for all additional expenses incurred by Canada, the Contractor, its subcontractors and suppliers at any tier due to the Contractor's use of the substitute.

GC3.6 SUBCONTRACTING

- 1) Subject to the provisions of this clause, the Contractor may subcontract any part of the Work but not the whole of the Work.
- 2) The Contractor shall notify Canada in writing of the Contractor's intention to subcontract.
- 3) A notification referred to in paragraph 2) of GC3.6 shall identify the part of the Work and the Subcontractor with whom the Contractor intends to subcontract.
- 4) Canada may for reasonable cause, object to the intended subcontracting by notifying the Contractor in writing within six (6) days of receipt by Canada of a notification referred to in paragraph 2) of GC3.6.
- 5) If Canada objects to a subcontracting, the Contractor shall not enter into the intended subcontract.
- 6) The Contractor shall not change, nor permit to be changed, a Subcontractor engaged by the Contractor, in accordance with this clause, without the written consent of Canada.
- 7) The Contractor shall ensure that all the terms and conditions of the Contract that are of general application shall be incorporated in every other contract issued as a consequence of the Contract, at whatever tier, except those contracts issued solely to suppliers at any tier for the supply of Plant or Material.
- 8) Neither a subcontracting nor Canada's consent to a subcontracting shall be construed to relieve the Contractor from any obligation under the Contract or to impose any liability upon Canada.

GC3.7 CONSTRUCTION BY OTHER CONTRACTORS OR WORKERS

- 1) Canada reserves the right to send other contractors or workers, with or without Plant and Material, onto the site of the Work.

- 2) When other contractors or workers are sent on to the site of the Work, Canada shall
 - (a) enter into separate contracts, to the extent it is possible, with the other contractors under conditions of contract that are compatible with the conditions of the Contract;
 - (b) ensure that the insurance coverage provided by the other contractors is co-ordinated with the insurance coverage of the Contractor as it affects the Work; and
 - (c) take all reasonable precautions to avoid labour disputes or other disputes arising from the work of the other contractors or workers.
- 3) When other contractors or workers are sent on to the site of the Work, the Contractor shall
 - (a) co-operate with them in the carrying out of their duties and obligations;
 - (b) co-ordinate and schedule the Work with the work of the other contractors and workers;
 - (c) participate with other contractors and workers in reviewing their construction schedules when directed to do so;
 - (d) where part of the Work is affected by or depends upon the work of other contractors or workers for its proper execution, promptly report to Canada in writing and prior to proceeding with that part of the Work, any apparent deficiencies in such work. Failure by the Contractor to so report shall invalidate any claims against Canada by reason of the deficiencies in the work of other contractors or workers except those deficiencies that are not then reasonably discoverable; and
 - (e) when designated as being responsible for construction safety at the place of work in accordance with the applicable provincial or territorial laws, carry out its duties in that role and in accordance with those laws.
- 4) If, when entering into the Contract, the Contractor could not have reasonably foreseen nor anticipated the sending of other contractors or workers on to the site of the Work and provided the Contractor
 - (a) incurs extra expense in complying with the requirements of paragraph 3) of GC3.7; and
 - (b) gives Canada written notice of a claim for that extra expense within thirty (30) days of the date that the other contractors or workers were sent onto the Work or its site;

Canada shall pay the Contractor the cost of the extra labour, Plant and Material that was necessarily incurred, calculated in accordance with GC6.4 DETERMINATION OF PRICE.

GC3.8 LABOUR

- 1) To the extent to which they are available, consistent with proper economy and the expeditious carrying out of the Work, the Contractor shall, in the performance of the Work, employ a reasonable number of persons who have been on active service with the Armed Forces of Canada and have been honourably discharged therefrom.

- 2) The Contractor shall maintain good order and discipline among the Contractor's employees and workers engaged in the Work and shall not employ on the site of the Work anyone not skilled in the tasks assigned.

GC3.9 TRUCK HAULAGE RATES

CANCELLED

GC3.10 MATERIAL, PLANT AND REAL PROPERTY BECOME PROPERTY OF CANADA

- 1) Subject to paragraph 9) of GC1.8 LAWS PERMITS AND TAXES, all Material and Plant and the interest of the Contractor in all real property, licences, powers and privileges purchased, used or consumed by the Contractor for the Work shall, immediately after the time of their purchase, use or consumption be the property of Canada for the purposes of the Work and they shall continue to be the property of Canada
 - (a) in the case of Material, until Canada indicates that the Materials shall not be required for the Work; and
 - (b) in the case of Plant, real property, licences, powers and privileges, until Canada indicates that the interest vested in Canada therein is no longer required for the purposes of the Work.
- 2) Material or Plant, that is the property of Canada by virtue of paragraph 1) of GC3.10, shall not be taken away from the site of the Work nor used nor disposed of except for the purposes of the Work without the written consent of Canada.
- 3) Canada is not liable for loss of nor damage from any cause to the Material or Plant referred to in paragraph 1) of GC3.10, and the Contractor is liable for such loss or damage notwithstanding that the Material or Plant is the property of Canada.

GC3.11 DEFECTIVE WORK

- 1) The Contractor shall promptly remove from the site of the Work and replace or re-execute defective Work whether or not the defective Work has been incorporated in the Work and whether or not the defect is the result of poor workmanship, use of defective Material, or damage through carelessness or other act or omission of the Contractor.
- 2) The Contractor, at the Contractor's expense, shall promptly make good other work destroyed or damaged by such removals or replacements.
- 3) If, in the opinion of Canada, it is not expedient to correct defective Work or Work not performed as provided for in the Contract documents, Canada may deduct from the amount otherwise due to the Contractor the difference in value between the Work as performed and that called for by the contract documents.
- 4) The failure of Canada to reject any defective Work or Material shall not constitute acceptance of the defective Work or Material.

GC3.12 CLEANUP OF SITE

- 1) The Contractor shall maintain the Work and its site in a tidy condition and free from an accumulation of waste material and debris.
- 2) Before the issue of a Certificate of Substantial Performance, the Contractor shall remove waste material and debris, and all Plant and Material not required for the performance of the remaining Work and, unless otherwise stipulated in the Contract Documents, shall cause the Work and its site to be clean and suitable for occupancy by Canada.
- 3) Before the issue of a Certificate of Completion, the Contractor shall remove all surplus Plant and Materials and any waste products and debris from the site of the Work.
- 4) The Contractor's obligations described in paragraphs 1) to 3) of GC3.12 do not extend to waste products and other debris caused by Canada's servants, or by other contractors and workers referred to in GC3.7 CONSTRUCTION BY OTHER CONTRACTORS OR WORKERS.

GC3.13 WARRANTY AND RECTIFICATION OF DEFECTS IN WORK

- 1) Without restricting any warranty or guarantee implied or imposed by law or contained in the Contract, the Contractor shall, at the Contractor's expense
 - (a) rectify and make good any defect or fault that appears in the Work or comes to the attention of Canada with respect to those parts of the Work accepted in connection with the Certificate of Substantial Performance within 12 months from the date of Substantial Performance; and
 - (b) rectify and make good any defect or fault that appears in or comes to the attention of Canada in connection with those parts of the Work described in the Certificate of Substantial Performance within 12 months from the date of the Certificate of Completion.
 - (c) transfer and assign, to Canada, any subcontractor, manufacturer or supplier extended warranties or guarantees implied or imposed by law or contained in the Contract covering periods beyond the 12 months stipulated above. Extended warranties or guarantees referred to herein shall not extend the 12-month period whereby the Contractor, except as may be provided elsewhere in the Contract, must rectify and make good any defect or fault that appears in the Work or comes to the attention of Canada.
 - (d) provide, to Canada prior to the issuance of the Certificate of Completion, a list of all extended warranties and guarantees referred to in paragraph (c) above.
- 2) Canada may direct the Contractor to rectify and make good any defect or fault referred to in paragraph 1) of GC3.13 or covered by any other expressed or implied warranty or guarantee and the Contractor shall rectify and make good such defect within the time stipulated in the direction.
- 3) A direction referred to in paragraph 2) GC3.13 shall be in writing and shall be given to the Contractor in accordance with GC2.3 NOTICES.

GC4 PROTECTIVE MEASURES

GC4.1 PROTECTION OF WORK AND PROPERTY

GC4.2 PRECAUTIONS AGAINST DAMAGE, INFRINGEMENT OF RIGHTS, FIRE AND OTHER HAZARDS

GC4.3 MATERIAL, PLANT AND REAL PROPERTY SUPPLIED BY CANADA

GC4.4 CONTAMINATED SITE CONDITIONS

GC4.1 PROTECTION OF WORK AND PROPERTY

- 1) The Contractor shall protect the Work and its site against loss or damage from any cause and shall similarly protect all Material, Plant and real property under the Contractor's care, custody and control whether or not such Material, Plant and real property are supplied by Canada to the Contractor.
- 2) The Contractor shall provide all facilities necessary for the purpose of maintaining security, and shall assist any person authorized by Canada to inspect or to take security measures in respect of the Work and its site.
- 3) Canada may direct the Contractor to do such things and to perform such work as Canada considers reasonable and necessary to ensure compliance with or to remedy a breach of paragraphs 1) or 2) of GC4.1, and the Contractor, shall comply with such direction.

GC4.2 PRECAUTIONS AGAINST DAMAGE, INFRINGEMENT OF RIGHTS, FIRE AND OTHER HAZARDS

- 1) The Contractor shall do whatever is necessary to ensure that
 - (a) no person, property, right, easement nor privilege is injured, damaged or infringed upon by reasons of the Contractor's activities in performing the Work;
 - (b) pedestrian and other traffic on any public or private road or waterway is not unduly impeded, interrupted nor endangered by the performance or existence of the Work, Material or Plant;
 - (c) fire hazards in or about the site of the Work are eliminated and any fire is promptly extinguished;
 - (d) the health and safety of all persons employed in the performance of the Work is not endangered by the methods nor means of their performance;
 - (e) adequate medical services are available to all persons employed on the Work or its site at all times during the performance of the Work;
 - (f) adequate sanitation measures are taken in respect of the Work and its site; and
 - (g) all stakes, buoys and marks placed on the Work or its site by Canada are protected and are not removed, defaced, altered nor destroyed.
- 2) Canada may direct the Contractor to do such things and to perform such work as Canada considers reasonable and necessary to ensure compliance with or to remedy a breach of paragraph 1) of GC4.2, and the Contractor shall comply with the direction of Canada.

GC4.3 MATERIAL, PLANT AND REAL PROPERTY SUPPLIED BY CANADA

- 1) Subject to paragraph 2) of GC4.3, the Contractor is liable to Canada for any loss of or damage to Material, Plant or real property that is supplied or placed in the care, custody and control of the Contractor by Canada for use in connection with the Contract, whether or not that loss or damage is attributable to causes beyond the Contractor's control.
- 2) The Contractor is not liable to Canada for any loss or damage to Material, Plant or real property referred to in paragraph 1) of GC4.3 if that loss or damage results from and is directly attributable to reasonable wear and tear.
- 3) The Contractor shall not use any Material, Plant or real property supplied by Canada except for the purpose of performing the Contract.
- 4) When the Contractor fails to make good any loss or damage for which the Contractor is liable under paragraph 1) within a reasonable time, Canada may cause the loss or damage to be made good at the Contractor's expense, and the Contractor shall thereupon be liable to Canada for the cost thereof and shall, on demand, pay to Canada an amount equal to that cost.
- 5) The Contractor shall keep records of all Material, Plant and real property supplied by Canada as Canada requires and shall satisfy Canada, when requested, that such Material, Plant and real property are at the place and in the condition in which they ought to be.

GC4.4 CONTAMINATED SITE CONDITIONS

- 1) For the purposes of GC4.4, a contaminated site condition exists when a solid, liquid, gaseous, thermal or radioactive irritant or contaminant, or other hazardous or toxic substance or material, including moulds and other forms of fungi, is present at the site of the Work to an extent that constitutes a hazard, or potential hazard, to the environment, property, or the health or safety of any person.
- 2) If the Contractor encounters a contaminated site condition of which the Contractor is not aware or about which the Contractor has not been advised, or if the Contractor has reasonable grounds to believe that such a site condition exists at the site of the Work, the Contractor shall
 - (a) take all reasonable steps, including stopping the Work, to ensure that no person suffers injury, sickness or death, and that neither property nor the environment is injured or destroyed as a result of the contaminated site condition;
 - (b) immediately notify Canada of the circumstances in writing; and
 - (c) take all reasonable steps to minimize additional costs that may accrue as a result of any work stoppage.
- 3) Upon receipt of a notification from the Contractor, Canada shall promptly determine whether a contaminated site condition exists, and shall notify the Contractor in writing of any action to be taken, or work to be performed, by the Contractor as a result of Canada's determination.
- 4) If the Contractor's services are required by Canada, the Contractor shall follow the direction of Canada with regard to any excavation, treatment, removal and disposal of any polluting substance or material.

- 5) Canada, at Canada's sole discretion, may enlist the services of experts and specialty contractors to assist in determining the existence of, and the extent and treatment of contaminated site conditions, and the Contractor shall allow them access and co-operate with them in the carrying out of their duties and obligations.
- 6) Except as may be otherwise provided for in the Contract, the provisions of GC6.4 DETERMINATION OF PRICE shall apply to any additional work made necessary because of a contaminated site condition.

GC5 TERMS OF PAYMENT

- GC5.1 INTERPRETATION
- GC5.2 AMOUNT PAYABLE
- GC5.3 INCREASED OR DECREASED COSTS
- GC5.4 PROGRESS PAYMENT
- GC5.5 SUBSTANTIAL PERFORMANCE OF THE WORK
- GC5.6 FINAL COMPLETION
- GC5.7 PAYMENT NOT BINDING ON CANADA
- GC5.8 CLAIMS AND OBLIGATIONS
- GC5.9 RIGHT OF SETOFF
- GC5.10 ASSESSMENTS AND DAMAGES FOR LATE COMPLETION
- GC5.11 DELAY IN MAKING PAYMENT
- GC5.12 INTEREST ON SETTLED CLAIMS
- GC5.13 RETURN OF SECURITY DEPOSIT

GC5.1 INTERPRETATION

In these Terms of Payment

- 1) The "payment period" means a period of 30 consecutive days or such other longer period as may be agreed between the Contractor and Canada.
- 2) An amount is "due and payable" when it is due and payable by Canada to the Contractor according to GC5.4 PROGRESS PAYMENT, GC5.5 SUBSTANTIAL PERFORMANCE OF THE WORK or GC5.6 FINAL COMPLETION.
- 3) An amount is "overdue" when it remains unpaid on the first day following the day upon which it is due and payable.
- 4) The "date of payment" means the date of the negotiable instrument of an amount due and payable by the Receiver General for Canada.
- 5) The "Bank Rate" means the rate of interest established by the Bank of Canada as the minimum rate at which it makes short term advances to members of the Canadian Payments Association.
- 6) The "Average Bank Rate" means the simple arithmetic mean of the Bank Rate in effect at 4:00 p.m. Eastern Time each day during the calendar month which immediately precedes the calendar month in which payment is made.

GC5.2 AMOUNT PAYABLE

- 1) Subject to any other provisions of the Contract, Canada shall pay the Contractor, at the times and in the manner hereinafter set out, the amount by which the amounts payable by Canada to the Contractor in accordance with the Contract exceed the amounts payable by the Contractor to Canada, and the Contractor shall accept that amount as payment in full satisfaction for everything furnished and done by the Contractor in respect of the Work to which the payment relates.
- 2) When making any payment to the Contractor, the failure of Canada to deduct an amount payable to Canada by the Contractor shall not constitute a waiver of the right to do so, or an admission of lack of entitlement to do so in any subsequent payment to the Contractor.

- 3) Should any payment be made by Canada in excess of what is owed to the Contractor for the actual work performed, the Contractor will reimburse Canada the excess immediately, with or without demand, and any amounts outstanding shall bear simple interest at the Average Bank rate plus 3 percent per annum from the date of overpayment until the day prior to the date of repayment by the Contractor.
- 4) No payment other than a payment that is expressly stipulated in the Contract shall be made by Canada to the Contractor for any extra expense or any loss or damage incurred or sustained by the Contractor.

GC5.3 INCREASED OR DECREASED COSTS

- 1) The Contract Amount shall not be increased nor decreased by reason of any increase or decrease in the cost of the Work that is brought about by an increase or decrease in the cost of labour, Plant, Material or any wage adjustment arising pursuant to the Labour Conditions.
- 2) Notwithstanding paragraph 1) of GC5.3, if any change, including a new imposition or repeal, of any tax, customs or other duty, charge, or any similar imposition that is imposed under sales, customs or excise tax legislation of the Government of Canada or any Provincial or Territorial legislation, affects the cost of the Work to the Contractor, and occurs
 - (a) after the date of submission by the Contractor of its bid; or
 - (b) after the date of submission of the last revision, if the Contractor's bid was revised;the Contract Amount shall be adjusted in the manner provided in paragraph 3) of GC5.3.
- 3) If a change referred to in paragraph 2) of GC5.3 occurs, the Contract Amount shall be increased or decreased by an amount established by an examination by Canada of the relevant records of the Contractor referred to in GC2.8 ACCOUNTS AND AUDITS to be the increase or decrease in the cost incurred by the Contractor that is directly attributable to that change.
- 4) For the purpose of paragraph 2) of GC5.3, if a tax is changed after the solicitation closing, but public notice of the change has been given by the Minister of Finance or the corresponding Provincial or Territorial authority before that closing, the change shall be deemed to have occurred before the solicitation closing.
- 5) Notwithstanding paragraphs 2) to 4) of GC5.3, no adjustment to the Contract Amount in respect of the Work or a part thereof shall be made for a change in any imposition referred to in this section that occurs after the date required by the Contract for completion of the Work or that part of the Work.

GC5.4 PROGRESS PAYMENT

- 1) On the expiration of a payment period, the Contractor shall deliver to Canada
 - (a) a written progress claim in a form acceptable to Canada that fully describes any part of the Work that has been completed, and any Material that was delivered to the Work site but not incorporated into the Work, during that payment period, and
 - (b) a completed and signed statutory declaration containing a declaration that, up to the date of the progress claim, the Contractor has complied with all lawful obligations with

respect to the Labour Conditions and that, in respect of the Work, all lawful obligations of the Contractor to its Subcontractors and Suppliers, referred to collectively in the declaration as “subcontractors and suppliers”, have been fully discharged.

- 2) Within 10 days of receipt of a progress claim and statutory declaration from the Contractor, Canada shall inspect, or cause to have inspected, the part of the Work and the Material described in the progress claim, and shall issue a progress report to the Contractor, that indicates the value of the part of the Work and the Material described in the progress claim that, in the opinion of Canada
 - (a) is in accordance with the Contract; and
 - (b) was not included in any other progress report relating to the Contract.
- 3) Subject to GC5.2 AMOUNT PAYABLE, and paragraph 5) of GC5.4, Canada shall pay the Contractor an amount that is equal to
 - (a) 95 percent of the value that is indicated in Canada's progress report if a labour and material payment bond has been furnished by the Contractor; or
 - (b) 90 percent of the value that is indicated in Canada's progress report if a labour and material payment bond has not been furnished by the Contractor.
- 4) Canada shall pay the amount referred to in paragraph 3) of GC5.4 not later than
 - (a) 30 days after receipt by Canada of both a progress claim and a statutory declaration referred to in paragraph 1) of GC5.4; or
 - (b) 15 days after receipt by Canada of the Contractor's progress schedule or updated progress schedule, in accordance with GC3.1 PROGRESS SCHEDULE,whichever is later.
- 5) In the case of the Contractor's first progress claim, it is a condition precedent to Canada's obligation under paragraph 3) of GC5.4 that the Contractor has provided all necessary documentation required by the Contract for the first progress claim.

GC5.5 SUBSTANTIAL PERFORMANCE OF THE WORK

- 1) If, at any time before the issuance of a Certificate of Completion, Canada determines that the Work has reached Substantial Performance as described in subparagraph 1) (b) of GC1.1.4 SUBSTANTIAL PERFORMANCE, Canada shall issue a Certificate of Substantial Performance to the Contractor. The Certificate of Substantial Performance shall state or describe
 - (a) the date of Substantial Performance;
 - (b) the parts of the Work not completed to the satisfaction of Canada; and
 - (c) all things that must be done by the Contractor before a Certificate of Completion is issued and before the 12-month warranty period referred to in GC3.13 WARRANTY AND RECTIFICATION OF DEFECTS IN WORK commences for the said parts and all the said things.

- 2) The issuance of a Certificate of Substantial Performance does not relieve the Contractor from the Contractor's obligations under GC3.11 DEFECTIVE WORK.
- 3) Subject to GC5.2 AMOUNT PAYABLE and paragraph 4) of GC5.5, Canada shall pay the Contractor the amount referred to in paragraph 1) of GC5.2 AMOUNT PAYABLE, less the aggregate of
 - (a) the sum of all payments that were made pursuant to GC5.4 PROGRESS PAYMENT;
 - (b) an amount that is equal to Canada's estimate of the cost to Canada of rectifying defects described in the Certificate of Substantial Performance; and
 - (c) an amount that is equal to Canada's estimate of the cost to Canada of completing the parts of the Work described in the Certificate of Substantial Performance other than defects listed therein.
- 4) Canada shall pay the amount referred to in paragraph 3) of GC5.5 not later than
 - (a) 30 days after the date of issue of a Certificate of Substantial Performance, or
 - (b) 15 days after the Contractor has delivered to Canada
 - (i) a statutory declaration containing a declaration by the Contractor that up to the date of the Certificate of Substantial Performance, the Contractor has complied with all lawful obligations with respect to the Labour Conditions, discharged all its lawful obligations to its Subcontractors and Suppliers in respect of the work under the Contract, and discharged its lawful obligations referred to in GC1.8 LAWS, PERMITS AND TAXES;
 - (ii) evidence of compliance with workers' compensation legislation in accordance with GC1.9 WORKERS' COMPENSATION; and
 - (iii) an update of the progress schedule in accordance with the requirements of GC3.1 PROGRESS SCHEDULE;

whichever is later.

GC5.6 FINAL COMPLETION

- 1) When Canada is of the opinion that the Contractor has complied with the Contract and all orders and directions made pursuant thereto, and that the Work has been completed as described in GC1.1.5 COMPLETION, Canada shall issue a Certificate of Completion to the Contractor and, if the Work or a portion of the Work is subject to a Unit Price Arrangement, Canada shall issue a Certificate of Measurement that shall, subject to GC8, be binding upon and conclusive between Canada and the Contractor as to the quantities referred to therein.
- 2) Subject to GC5.2 AMOUNT PAYABLE and paragraph 3) of GC5.6, Canada shall pay the Contractor the amount referred to in GC5.2 AMOUNT PAYABLE, less the aggregate of the sum of all payments that were made pursuant to GC5.4 PROGRESS PAYMENT and GC5.5 SUBSTANTIAL PERFORMANCE OF WORK.
- 3) Canada shall pay the amount referred to in paragraph 2) of GC5.6 not later than
 - (a) 60 days after the date of issue of a Certificate of Completion; or

- (b) 15 days after the Contractor has delivered to Canada
 - (i) a statutory declaration which contains a declaration by the Contractor that all of the Contractor's lawful obligations and any lawful claims against the Contractor that arose out of the performance of the Contract have been discharged and satisfied; and
 - (ii) evidence of compliance with workers' compensation legislation in accordance with GC1.9 WORKERS' COMPENSATION;

whichever is later.

GC5.7 PAYMENT NOT BINDING ON CANADA

- 1) Neither acceptance of a progress claim or progress report, nor any payment made by Canada under the Contract, nor partial or entire use or occupancy of the Work by Canada shall constitute an acceptance by Canada of any portion of the Work or Material that is not in accordance with the requirements of the Contract.

GC5.8 CLAIMS AND OBLIGATIONS

- 1) The Contractor shall discharge all the Contractor's lawful obligations and shall satisfy all lawful claims against the Contractor arising out of the performance of the Work at least as often as the Contract requires Canada to pay the Contractor.
- 2) Whenever requested to do so by Canada, the Contractor shall make a statutory declaration declaring to the existence and condition of any obligations and claims against the Contractor arising out of the performance of the Work.
- 3) In order to discharge lawful obligations of and satisfy lawful claims against the Contractor or its Subcontractors arising out of the performance of the Contract, Canada may pay an amount that is due and payable to the Contractor directly to the claimant. Such payment is, to the extent of the payment, a discharge of Canada's liability to the Contractor under the Contract and may be deducted from any amount payable to the Contractor under the Contract.
- 4) For the purposes of paragraph 3) of GC5.8, and subject to paragraph 6) of GC5.8, a claim or obligation shall be considered lawful when it is so determined by
 - (a) a court of legal jurisdiction;
 - (b) an arbitrator duly appointed to arbitrate the claim; or
 - (c) the written consent of the Contractor authorizing payment of the claim or obligation.
- 5) If a claim or obligation would have been subject to the provisions of Provincial or Territorial lien legislation or, in the Province of Quebec, the law relating to legal hypothecs had the Contractor been performing the Work for an entity other than Canada
 - (a) such amount as may be paid by Canada pursuant to paragraphs 3) and 4) of GC5.8 shall not exceed the amount that the Contractor would have been obliged to pay had the provisions of such legislation or law been applicable to the Work;

- (b) a claimant need not comply with the provisions of such legislation, setting out the steps by way of notice, registration or otherwise as might have been necessary to preserve or perfect any claim for lien or privilege which the claimant might have had; and
 - (c) for the purposes of determining the entitlement of a claimant, the notice required by paragraph 8) of GC5.8 shall be deemed to replace the registration or provision of notice after the performance of work as required by any applicable legislation and no claim shall be deemed to have expired, become void or unenforceable by reason of the claimant not commencing any action within the time prescribed by such legislation.
- 6) The Contractor shall, at the request of any claimant, submit to binding arbitration those questions that need to be answered to establish the entitlement of the claimant to payment. The arbitration shall have as parties to it any Subcontractor or Supplier to whom the claimant supplied Material, performed work or rented equipment should such Subcontractor or Supplier wish to be adjoined, and Canada shall not be a party to such arbitration. Subject to any agreement between the Contractor and the claimant, the arbitration shall be conducted in accordance with the governing Provincial or Territorial legislation applicable to the site of the Work.
- 7) Paragraph 3) of GC5.8 shall apply only to claims and obligations
- (a) the notification of which has set forth the amount claimed to be owing and the person who by contract is primarily liable and has been received by Canada in writing before final payment is made to the Contractor pursuant to GC5.6 FINAL COMPLETION, and within 120 days of the date on which the claimant
 - (i) should have been paid in full under the claimant's contract with the Contractor, its Subcontractor or Supplier if the claim is for money that was lawfully required to be held back from the claimant; or
 - (ii) performed the last of the services, work or labour, or furnished the last of the Material pursuant to the claimant's contract with the Contractor or its Subcontractor or Supplier where the claim is for money not lawfully required to be held back from the claimant; and
 - (b) the proceedings to determine the right to payment of which, pursuant to paragraph 5) of GC5.8, shall have commenced within one year from the date that the notification required by subparagraph 7)(a) of GC5.8 was received by Canada.
- 8) Upon receipt of a notice of claim, Canada may withhold, from any amount that is due and payable to the Contractor pursuant to the Contract, the full amount of the claim or any portion thereof.
- 9) Canada shall notify the Contractor in writing in a timely manner of receipt of any claim and of the intention of Canada to withhold funds. At any time thereafter and until payment is made to the claimant, the Contractor may be entitled to post, with Canada, security in a form acceptable to Canada in an amount equal to the value of the claim, and upon receipt of such security Canada shall release to the Contractor any funds that would be otherwise payable to the Contractor, that were withheld pursuant to the provisions of this clause in respect of the claim of any claimant for whom the security stands.

GC5.9 RIGHT OF SETOFF

- 1) Without limiting any right of setoff or deduction given or implied by law or elsewhere in the Contract, Canada may set off any amount payable to Canada by the Contractor under the

Contract, or under any current contract, against any amount payable to the Contractor under the Contract.

- 2) For the purposes of paragraph 1) of GC5.9, "current contract" means a contract between Canada and the Contractor
 - (a) under which the Contractor has an undischarged obligation to perform or supply work, labour or material; or
 - (b) in respect of which Canada has, since the date of the Contract, exercised any right to take the work that is the subject of that contract out of the Contractor's hands.

GC5.10 ASSESSMENTS AND DAMAGES FOR LATE COMPLETION

- 1) For the purposes of this clause
 - (a) the Work shall be deemed to be completed on the date of the Certificate of Completion; and
 - (b) the "period of delay" means the number of days commencing on the day fixed for completion of the Work and ending on the day immediately preceding the day on which the Work is completed but does not include any day within a period of extension granted pursuant to GC6.5 DELAYS AND EXTENSION OF TIME and any other day on which, in the opinion of Canada, completion of the Work was delayed for reasons beyond the control of the Contractor.
- 2) If the Contractor does not complete the Work by the day fixed for its completion but completes it thereafter, the Contractor shall pay Canada an amount equal to the aggregate of
 - (a) all salaries, wages and travelling expenses incurred by Canada in respect of persons overseeing the performance of the Work during the period of delay;
 - (b) the cost incurred by Canada as a result of the inability to use the completed Work for the period of delay; and
 - (c) all other expenses and damages incurred or sustained by Canada during the period of delay as a result of the Work not being completed by the day fixed for its completion.
- 3) Canada may waive the right of Canada to the whole or any part of the amount payable by the Contractor pursuant to paragraph 2) of GC5.10 if, in the opinion of Canada, it is in the public interest to do so.

GC5.11 DELAY IN MAKING PAYMENT

- 1) Notwithstanding GC1.5 TIME OF THE ESSENCE, any delay by Canada in making any payment when it is due pursuant to GC5 TERMS OF PAYMENT, shall not be a breach of the Contract by Canada.
- 2) Subject to paragraph 3) of GC5.11, Canada shall pay to the Contractor simple interest at the Average Bank Rate plus 3 percent per annum on any amount that is overdue pursuant to paragraph 3) of GC5.1 INTERPRETATION, and the interest shall apply from and include the day such amount became overdue until the day prior to the date of payment.

- 3) Interest shall be paid without demand by the Contractor except that
 - (a) in respect of amounts that are less than 15 days overdue, no interest shall be paid in respect of payment made within such 15 days unless the Contractor so demands after such amounts have become due and payable; and
 - (b) interest shall not be payable or paid on overdue advance payments, if any.

GC5.12 INTEREST ON SETTLED CLAIMS

- 1) For the purposes of this clause, a claim means a disputed amount subject to negotiation between Canada and the Contractor under the Contract.
- 2) A claim is deemed to have been settled when an agreement in writing is signed by Canada and the Contractor setting out the amount of the claim to be paid by Canada and the items of work for which the said amount is to be paid.
- 3) A settled claim is deemed to be outstanding from the day immediately following the date the said claim would have been due and payable under the Contract had it not been disputed.
- 4) Canada shall pay to the Contractor simple interest on the amount of a settled claim at the Average Bank Rate plus 3 percent per annum from the date the settled claim was deemed to be outstanding until the day prior to the date of payment.

GC5.13 RETURN OF SECURITY DEPOSIT

- 1) After a Certificate of Substantial Performance has been issued, and if the Contractor is not in breach of nor in default under the Contract, Canada shall return to the Contractor all or any part of a Security Deposit that, in the opinion of Canada, is not required for the purposes of the Contract.
- 2) After a Certificate of Completion has been issued, Canada shall return to the Contractor the remainder of any security deposit unless the Contract stipulates otherwise.
- 3) If the security deposit was paid into the Consolidated Revenue Fund of Canada, Canada shall pay interest thereon to the Contractor at a rate established pursuant to section 21(2) of the [*Financial Administration Act \(FAA\)*](#).

GC6 DELAYS AND CHANGES IN THE WORK

- GC6.1 CHANGES IN THE WORK
- GC6.2 CHANGES IN SUBSURFACE CONDITIONS
- GC6.3 HUMAN REMAINS, ARCHAEOLOGICAL REMAINS AND ITEMS OF HISTORICAL OR SCIENTIFIC INTEREST
- GC6.4 DETERMINATION OF PRICE
 - GC6.4.1 Price Determination Prior to Undertaking Changes
 - GC6.4.2 Price Determination Following Completion of Changes
 - GC6.4.3 Price Determination - Variations in Tendered Quantities
- GC6.5 DELAYS AND EXTENSION OF TIME

GC6.1 CHANGES IN THE WORK

- 1) At any time before issuance of a Certificate of Completion, Canada may issue orders for additions, deletions or other changes to the Work, or changes in the location or position of the whole or any part of the Work, if the addition, deletion, change or other revision is deemed by Canada to be consistent with the general intent of the Contract.
- 2) An order referred to in paragraph 1) of GC6.1 shall be in writing and given to the Contractor in accordance with GC2.3 NOTICES.
- 3) Upon receipt of an order, the Contractor shall promptly perform the work in accordance with the order as if the order had appeared in and been part of the original Contract.
- 4) If anything done or omitted by the Contractor pursuant to an order increases or decreases the cost of the Work to the Contractor, payment for the work shall be made in accordance with GC6.4 DETERMINATION OF PRICE.

GC6.2 CHANGES IN SUBSURFACE CONDITIONS

- 1) If, during the performance of the Work, the Contractor encounters subsurface conditions that are substantially different from the subsurface conditions described in the tender documents supplied to the Contractor, or a reasonable assumption of fact based thereon, the Contractor shall give notice to Canada immediately upon becoming aware of the situation.
- 2) If the Contractor is of the opinion that the Contractor may incur or sustain any extra expense or any loss or damage that is directly attributable to the changed subsurface conditions, the Contractor shall within 10 days of the date the changed subsurface conditions were encountered, give Canada written notice of intention to claim for that extra expense, loss or damage.
- 3) If the Contractor has given a notice referred to in paragraph 2) of GC6.2, the Contractor shall give Canada a written claim for extra expense, loss or damage no later than 30 days after the date that a Certificate of Substantial Performance is issued.
- 4) A written claim referred to in paragraph 3) of GC6.2 shall contain a sufficient description of the facts and circumstances of the occurrence that is the subject of the claim to enable Canada to determine whether or not the claim is justified, and the Contractor shall supply such further and other information for that purpose as Canada requires.
- 5) If Canada determines that a claim referred to in paragraph 3) of GC6.2 is justified, Canada shall make an extra payment to the Contractor in an amount that is calculated in accordance with GC6.4 DETERMINATION OF PRICE.

- 6) If, in the opinion of Canada, the Contractor effects a saving of expenditure that is directly attributable to a substantial difference between the information relating to subsurface conditions at the site of the Work that is contained in the tender documents, or a reasonable assumption of fact based thereon, and the actual subsurface conditions encountered by the Contractor, the Contract Amount shall be reduced by the amount of the saving of expenditure determined in accordance with GC6.4 DETERMINATION OF PRICE.
- 7) If the Contractor fails to give a notice referred to in paragraph 2) of GC6.2 and a claim referred to in paragraph 3) of GC6.2 within the times stipulated, an extra payment shall not be made to the Contractor in respect of the occurrence.
- 8) Canada does not warrant the content expressed in any subsurface report available for the perusal of the Contractor that does not form part of the tender and contract documents.

GC6.3 HUMAN REMAINS, ARCHAEOLOGICAL REMAINS AND ITEMS OF HISTORICAL OR SCIENTIFIC INTEREST

- 1) For the purposes of this clause
 - (a) "human remains" means the whole or any part of a deceased human being, irrespective of the time of death;
 - (b) "archaeological remains" are items, artefacts or things made, modified or used by human beings in antiquity and may include, but not be limited to, stone, wood or iron structures or monuments, dump deposits, bone artefacts, weapons, tools, coins, and pottery; and
 - (c) "items of historical or scientific interest" are naturally occurring or manufactured objects or things of any age that are not archaeological remains but may be of interest to society because of their historical or scientific significance, value, rarity, natural beauty, or other quality.
- 2) If, during the course of the Work, the Contractor encounters any object, item or thing which is described in paragraph 1) of GC6.3 or which resembles any object, item or thing described in paragraph 1) of GC6.3, the Contractor shall
 - (a) take all reasonable steps, including stopping work in the affected area, to protect and preserve the object, item or thing;
 - (b) immediately notify Canada of the circumstances in writing; and
 - (c) take all reasonable steps to minimize additional costs that may accrue as a result of any work stoppage.
- 3) Upon receipt of a notification in accordance with subparagraph 2)(b) of GC6.3, Canada shall promptly determine whether the object, item or thing is one described in, or contemplated by paragraph 1) of GC6.3, and shall notify the Contractor in writing of any action to be performed, or work to be carried out, by the Contractor as a result of Canada's determination.
- 4) Canada may, at any time, enlist the services of experts to assist in the investigation, examination, taking of measurements or other such recordings, placing of permanent protection around or removing of the object, item or thing encountered by the Contractor, and the Contractor shall, to the satisfaction of Canada, allow them access and co-operate with them in the carrying out of their duties and obligations.

- 5) Human remains, archaeological remains and items of historical or scientific interest encountered at the site of the Work shall be deemed to be the property of Canada.
- 6) Except as may be otherwise provided for in the Contract, the provisions of GC6.4 DETERMINATION OF PRICE and GC6.5 DELAYS AND EXTENSION OF TIME shall apply.

GC6.4 DETERMINATION OF PRICE

GC6.4.1 Price Determination Prior to Undertaking Changes

- 1) If a Lump Sum Arrangement applies to the Contract or a part thereof, the price of any change shall be the aggregate estimated cost of labour, Plant and Material that is required for the change as agreed upon in writing by the Contractor and Canada plus a negotiated allowance for supervision, co-ordination, administration, overhead, margin and the risk of undertaking the work within the stipulated amount.
- 2) If a Unit Price Arrangement applies to the Contract or a part thereof, the Contractor and Canada may, by agreement in writing, add items, units of measurement, estimated quantities and prices per unit to the Unit Price Table.
- 3) A price per unit referred to in paragraph 2) of GC6.4.1 shall be determined on the basis of the aggregate estimated cost of labour, Plant and Material that is required for the additional item as agreed upon by the Contractor and Canada, plus a negotiated allowance.
- 4) To facilitate approval of the price of the change or the additional price per unit as applicable, the Contractor shall submit a cost estimate breakdown identifying, as a minimum, the estimated cost of labour, Plant, Material, each subcontract amount, and the amount of the negotiated allowance.
- 5) If no agreement is reached as contemplated in paragraph 1) of GC6.4.1, the price shall be determined in accordance with GC6.4.2.
- 6) If no agreement is reached, as contemplated in paragraphs 2) and 3) of GC6.4.1, Canada shall determine the class and the unit of measurement of the item of labour, Plant or Material and the price per unit shall be determined in accordance with GC6.4.2.

GC6.4.2 Price Determination Following Completion of Changes

- 1) If it is not possible to predetermine, or if there is failure to agree upon the price of a change in the Work, the price of the change shall be equal to the aggregate of
 - (a) all reasonable and proper amounts actually expended or legally payable by the Contractor in respect of the labour, Plant and Material that fall within one of the classes of expenditure described in paragraph 2) of GC6.4.2, that are directly attributable to the performance of the Contract;
 - (b) an allowance for profit and all other expenditures or costs, including overhead, general administration costs, financing and interest charges, in an amount that is equal to 10 percent of the sum of the expenses referred to in subparagraph 1)(a) of GC6.4.2; and
 - (c) interest on the amounts determined under subparagraphs 1)(a) and 1)(b) of GC6.4.2 calculated in accordance with GC5.12 INTEREST ON SETTLED CLAIMS;

- 2) The cost of labour, Plant and Material referred to in subparagraph 1)(a) of GC6.4.2 shall be limited to the following categories of expenditure:
- (a) payments to Subcontractors and Suppliers;
 - (b) wages, salaries, bonuses and, if applicable, travel and lodging expenses of employees of the Contractor located at the site of the Work and that portion of wages, salaries, bonuses and, if applicable, travel and lodging expenses of personnel of the Contractor generally employed at the head office or at a general office of the Contractor provided they are actually and properly engaged on the Work under the Contract;
 - (c) assessments payable under any statutory authority relating to workers' compensation, employment insurance, pension plan or holidays with pay, provincial health or insurance plans, environmental reviews, and Applicable Taxes collection costs;
 - (d) rent that is paid for Plant, or an amount equivalent to the said rent if the Plant is owned by the Contractor, that is necessary for and used in the performance of the Work, if the rent or the equivalent amount is reasonable and use of that Plant has been approved by Canada;
 - (e) payments for maintaining and operating Plant necessary for and used in the performance of the Work, and payments for effecting repairs thereto that, in the opinion of Canada, are necessary for the proper performance of the Contract, other than payments for any repairs to the Plant arising out of defects existing before its allocation to the Work;
 - (f) payments for Material that is necessary for and incorporated in the Work, or that is necessary for and consumed in the performance of the Contract;
 - (g) payments for preparation, delivery, handling, erection, installation, inspection, protection and removal of the Plant and Material necessary for and used in the performance of the Contract; and
 - (h) any other payments made by the Contractor with the approval Canada that are necessary for the performance of the Contract in accordance with the Contract Documents.

GC6.4.3 Price Determination - Variations in Tendeded Quantities

- 1) Except as provided in paragraphs 2), 3), 4) and 5) of GC6.4.3, if it appears that the final quantity of labour, Plant and Material under a price per unit item shall exceed or be less than the estimated tendered quantity, the Contractor shall perform the Work or supply the Plant and Material required to complete the item and payment shall be made for the actual Work performed or Plant and Material supplied at the price per unit set out in the Contract.
- 2) If the final quantity of the price per unit item exceeds the estimated tendered quantity by more than 15 percent, either party to the Contract may make a written request to the other party to negotiate an amended price per unit for that portion of the item which exceeds 115 percent of the estimated tendered quantity, and to facilitate approval of any amended price per unit, the Contractor shall, on request, provide Canada with
- (a) detailed records of the actual cost to the Contractor of performing or supplying the tendered quantity for the price per unit item up to the time the negotiation was requested; and

- (b) the estimated unit cost of labour, Plant and Material required for the portion of the item that is in excess of 115 percent of the tendered quantity.
- 3) If agreement is not reached as contemplated in paragraph 2) of GC6.4.3, the price per unit shall be determined in accordance with GC6.4.2.
 - 4) If it appears that the final quantity of labour, Plant and Material under a price per unit item shall be less than 85 percent of the estimated tendered quantity, either party to the Contract may make a written request to the other party to negotiate a change to the price per unit for the item if
 - (a) there is a demonstrable difference between the unit cost to the Contractor of performing or supplying the estimated tendered quantity and the unit cost to the Contractor for performing or supplying the final quantity; and
 - (b) the difference in unit cost is due solely to the decrease in quantity and not to any other cause.
 - 5) For the purposes of the negotiation referred to in paragraph 4) of GC6.4.3
 - (a) the onus of establishing, justifying and quantifying a proposed change lies with the party making the request for negotiation; and
 - (b) in no event shall the total price for an item that has been amended as a result of a reduction in quantity pursuant to paragraph 4) of GC6.4.3 exceed the amount that would have been payable to the Contractor had 85 percent of the tendered quantity actually been performed or supplied.

GC6.5 DELAYS AND EXTENSION OF TIME

- 1) Upon application of the Contractor made before the date first fixed for completion of the Work or before any other date previously fixed under this clause, Canada may extend the time for completion of the Work by fixing a new date if Canada determines that causes beyond the control of the Contractor have delayed its completion.
- 2) The Contractor's application shall be accompanied by the written consent of the bonding company whose bond forms part of the Contract Security.
- 3) Subject to paragraph 4) of GC6.5, no payment, other than a payment that is expressly stipulated in the Contract, shall be made by Canada to the Contractor for any extra expense, loss or damage incurred or sustained by the Contractor due to delay, whether or not the delay is caused by circumstances beyond the control of the Contractor.
- 4) If the Contractor incurs or sustains any extra expense or any loss or damage that is directly attributable to any neglect or delay that occurs after the date of the Contract on the part of Canada in providing any information or in doing any act that the Contract either expressly requires Canada to do or that would ordinarily be done by an owner in accordance with the practice of the trade, the Contractor shall give Canada written notice of intention to claim for that extra expense or loss or damage within ten working days of the date the neglect or delay first occurred.
- 5) When the Contractor has given a notice referred to in paragraph 4) of GC6.5, the Contractor shall give Canada a written claim for the extra expense, loss or damage no later than 30 days after the date that a Certificate of Completion is issued and not afterwards.

- 6) A written claim referred to in paragraph 5) of GC6.5 shall contain a sufficient description of the facts and circumstances of the occurrence that is the subject of the claim to enable Canada to determine whether or not the claim is justified and the Contractor shall supply such further and other information for that purpose as Canada may require.
- 7) If Canada determines that a claim referred to in paragraph 5) of GC6.5 is justified, Canada shall make an extra payment to the Contractor in an amount that is calculated in accordance with GC6.4 DETERMINATION OF PRICE.
- 8) If the Contractor fails to give a notice referred to in paragraph 4) and a claim referred to in paragraph 5) of GC6.5 within the times stipulated, an extra payment shall not be made to the Contractor in respect of the occurrence.

GC7 DEFAULT, SUSPENSION OR TERMINATION OF CONTRACT

GC7.1 TAKING THE WORK OUT OF THE CONTRACTOR'S HANDS

GC7.2 SUSPENSION OF WORK

GC7.3 TERMINATION OF CONTRACT

GC7.4 SECURITY DEPOSIT - FORFEITURE OR RETURN

GC7.1 TAKING THE WORK OUT OF THE CONTRACTOR'S HANDS

- 1) By giving notice in writing to the Contractor in accordance with GC2.3 NOTICES, Canada, without any other authorization, may take all or any part of the Work out of the Contractor's hands, and may employ such means as Canada sees fit to have the Work completed if the Contractor:
 - (a) fails to remedy any delay in the commencement or default in the diligent performance of the Work to the satisfaction of Canada within six days of Canada giving notice to the Contractor in writing in accordance with GC2.3 NOTICES;
 - (b) defaults in the completion of any part of the Work within the time fixed for its completion by the Contract;
 - (c) becomes insolvent, or has committed an act of bankruptcy, and has neither made a proposal to its creditors nor filed a notice of intention to make such a proposal, pursuant to the [*Bankruptcy and Insolvency Act*](#);
 - (d) abandons the work;
 - (e) makes an assignment of the Contract without the consent required by GC1.16 ASSIGNMENT; or
 - (f) otherwise fails to observe or perform any of the provisions of the Contract.
- 2) If the whole or any part of the Work is taken out of the Contractor's hands, the Contractor's right to any further payment that is due or accruing due under the Contract is, subject only to paragraph 3) of GC7.1, extinguished, and the Contractor is liable to pay Canada, upon demand, an amount that is equal to the amount of all loss and damage incurred or sustained by Canada in respect of the Contractor's failure to complete the Work.
- 3) If the whole or any part of the Work that is taken out of the Contractor's hands is completed by Canada, Canada may pay the Contractor the amount, if any, of the holdback or a progress claim as determined by Canada that had accrued and was due prior to the date on which the Work was taken out of the Contractor's hands and that is not required for the purposes of having the Work performed or of compensating Canada for any other loss or damage incurred or sustained by reason of the Contractor's default.
- 4) The taking of the Work or any part thereof out of the Contractor's hands does not relieve the Contractor from any obligation under the Contract or imposed by law except the obligation to complete the performance of that part of the Work that was taken out of the Contractor's hands.
- 5) If the Work or any part thereof is taken out of the Contractor's hands, all Plant and Material and the interest of the Contractor, or its suppliers or subcontractors at any tier, in all real property, licences, powers and privileges acquired, used or provided by the Contractor, or its suppliers or subcontractors at any tier, under the Contract shall continue to be the property of Canada without compensation.

- 6) When Canada certifies that any Plant, Material, or any interest of the Contractor is no longer required for the purposes of the Work, or that it is not in the interests of Canada to retain that Plant, Material, or interest, it shall revert to the Contractor.
- 7) If the Contractor has become insolvent or has committed an act of bankruptcy, and has either made a proposal to its creditors or filed a notice of intention to make such a proposal, pursuant to the [Bankruptcy and Insolvency Act](#), the Contractor shall immediately forward a copy of the proposal or the notice of intention to Canada.

GC7.2 SUSPENSION OF WORK

- 1) When, in Canada's opinion, it is in the public interest to do so, Canada may require the Contractor to suspend performance of the Work either for a specified or an unspecified period, by giving a notice of suspension in writing to the Contractor in accordance with GC2.3 NOTICES.
- 2) When a notice of suspension is received by the Contractor, the Contractor shall suspend all operations in respect of the Work except those that Canada determines are necessary for the care and preservation of the Work, Plant and Material.
- 3) During a period of suspension, the Contractor shall not remove any part of the Work, Plant or Material from its site without the consent of Canada.
- 4) If a period of suspension is 60 days or less, the Contractor shall resume the performance of the Work on the expiration of that period, and the Contractor is entitled to be paid the extra costs necessarily incurred by the Contractor as a result of the suspension, determined in accordance with GC6.4 DETERMINATION OF PRICE.
- 5) If a period of suspension is more than 60 days, Canada and the Contractor may agree that the performance of the Work shall be continued by the Contractor, and the Contractor shall resume performance of the Work subject to any terms and conditions agreed upon by Canada and the Contractor. If Canada and the Contractor do not agree that performance of the Work shall be continued by the Contractor, or upon the terms and conditions under which the Contractor shall continue the Work, the notice of suspension shall be deemed to be a notice of termination pursuant to GC7.3 TERMINATION OF CONTRACT.

GC7.3 TERMINATION OF CONTRACT

- 1) Canada may terminate the Contract at any time by giving a notice of termination in writing to the Contractor in accordance with GC2.3 NOTICES.
- 2) If the Contractor receives a notice of termination, the Contractor shall forthwith cease all operations in performance of the Contract, subject to any conditions stipulated in the notice.
- 3) Subject to paragraph 4) of GC7.3, if the Contract is terminated, Canada shall pay the Contractor an amount determined to be due to the Contractor pursuant to GC6.4 DETERMINATION OF PRICE less the aggregate of all amounts that were paid to the Contractor by Canada and all amounts that are due to Canada from the Contractor pursuant to the Contract.
- 4) In no event shall the total amount payable by Canada to the Contractor exceed the amount, calculated in accordance with GC5 TERMS OF PAYMENT, that would have been payable to the Contractor had the Contractor completed the Work.

- 5) Payment to the Contractor, if any, shall be made as soon as practicable under the circumstances.

GC7.4 SECURITY DEPOSIT - FORFEITURE OR RETURN

- 1) If the Work is taken out of the Contractor's hands, or the Contractor is in breach of, or in default under, the Contract, Canada may convert a security deposit to Canada's own use.
- 2) If Canada converts a security deposit, the amount realized shall be deemed to be an amount due from Canada to the Contractor under the Contract.
- 3) Any balance of the amount realized that remains after payment of all losses, damage and claims of Canada and others shall be paid by Canada to the Contractor if, in the opinion of Canada, it is not required for the purposes of the Contract.

GC8 DISPUTE RESOLUTION

- GC8.1 INTERPRETATION
- GC8.2 CONSULTATION AND CO-OPERATION
- GC8.3 NOTICE OF DISPUTE
- GC8.4 NEGOTIATION
- GC8.5 MEDIATION
- GC8.6 CONFIDENTIALITY
- GC8.7 SETTLEMENT
- GC8.8 RULES FOR MEDIATION OF DISPUTES
 - GC8.8.1 Interpretation
 - GC8.8.2 Application
 - GC8.8.3 Communication
 - GC8.8.4 Appointment of Project Mediator
 - GC8.8.5 Confidentiality
 - GC8.8.6 Time and Place of Mediation
 - GC8.8.7 Representation
 - GC8.8.8 Procedure
 - GC8.8.9 Settlement Agreement
 - GC8.8.10 Termination of Mediation
 - GC8.8.11 Costs
 - GC8.8.12 Subsequent Proceedings

GC8.1 INTERPRETATION

- 1) "dispute" means any disagreement regarding any issue identified by the Contractor in the notice submitted to Canada in accordance with paragraph 2 of GC8.3 NOTICE OF DISPUTE, and includes any claim by the Contractor arising from such disagreement and any counterclaim by Canada, but does not include any claim by either party for punitive or exemplary damages, injury to persons, death, or any claim based on an allegation of libel or slander.
- 2) The alternative dispute resolution procedures set out in GC8, do not apply to any claim by Canada against the Contractor except any counterclaim in a dispute as defined in paragraph 1 of GC8.1, including, but not limited to, any claim of setoff regarding any amount due to Canada under GC5.10 ASSESSMENT AND DAMAGES FOR LATE COMPLETION.

GC8.2 CONSULTATION AND CO-OPERATION

- 1) The parties agree to maintain open and honest communication throughout the performance of the Contract.
- 2) The parties agree to consult and co-operate with each other in the furtherance of the Work and the resolution of problems or differences that may arise.

GC8.3 NOTICE OF DISPUTE

- 1) Any difference between the parties to the Contract of any nature arising out of or in connection with the Contract which could result in a claim by the Contractor against Canada, and which is not settled by consultation and co-operation as envisaged in GC8.2 CONSULTATION AND CO-OPERATION, shall be resolved in the first instance by Canada, whose written decision or direction shall be final and binding subject only to the provisions of

GC8. Such written decision or direction includes, but is not limited to, any written decision or direction by Canada under any provision of the General Conditions.

- 2) The Contractor shall be deemed to have accepted the decision or direction of Canada referred to in paragraph 1) of GC8.3 and to have expressly waived and released Canada from any claim in respect of the particular matter dealt with in that decision or direction unless, within 15 working days after receipt of the decision or direction, the Contractor submits to Canada a written notice of dispute requesting formal negotiation under GC8.4 NEGOTIATION. Such notice shall refer specifically to GC8.4 NEGOTIATION, and shall specify the issues in contention and the relevant provisions of the Contract.
- 3) The giving of a written notice in accordance with paragraph 2) of GC8.3 shall not relieve the Contractor from complying with the decision or direction that is the subject of the dispute. Such compliance, however, shall not be construed as an admission by the Contractor of the correctness of such decision or direction.
- 4) If a dispute is not resolved promptly, Canada shall give such instructions as, in Canada's opinion, are necessary for the proper performance of the Work and to prevent delays pending a resolution of the matter. Unless Canada terminates the Contract, orders the Contractor to suspend the Work, or takes the Work out of the hands of the Contractor, the Contractor shall continue to perform the Work in accordance with the provisions and requirements of the Contract and the instructions of Canada. Such performance shall not prejudice any claim that the Contractor may have.
- 5) Nothing in GC8 relieves the Contractor from its obligation to provide any other notice required by the Contract within the time specified in the Contract, including but not limited to, any notice required under GC6.2 CHANGES IN SUBSURFACE CONDITIONS.

GC8.4 NEGOTIATION

- 1) Within 10 working days after receipt by Canada of a notice referred to in paragraph 2) of GC8.3 NOTICE OF DISPUTE, or within such other period of time as may be mutually agreed to, the parties shall commence formal negotiations in order to resolve the dispute. Negotiations shall occur initially between representatives of the Contractor and Canada who play a direct supervisory role in the performance, administration or management of the Contract.
- 2) If the representatives referred to in paragraph 1) of GC8.4 are unable to resolve some or all of the issues which are the subject of the negotiations within 10 working days, the parties shall refer the remaining issues which are in dispute to a second level of negotiation between a principal or principals of the Contractor and a senior level manager or senior level managers representing Canada.
- 3) If negotiations fail to resolve the dispute within 30 working days from the date of delivery of the notice referred to in paragraph 2) of GC8.3 NOTICE OF DISPUTE, or within such longer period as may have been agreed to by the parties, the Contractor may, by giving written notice to Canada, in accordance with GC2.3 NOTICES, within 10 working days from the end of such period, request that mediation be undertaken to assist the parties to reach agreement on the outstanding issues.
- 4) If the Contractor does not request mediation within the period permitted by paragraph 3) of GC8.4, the Contractor shall be deemed to have accepted the decision or direction of Canada under paragraph 1) of GC8.3 NOTICE OF DISPUTE and to have expressly waived and released Canada from any claim in respect of the particular matter dealt with in that decision or direction.

GC8.5 MEDIATION

- 1) If the Contractor has requested mediation in accordance with paragraph 3) of GC8.4 NEGOTIATION, mediation shall be conducted in accordance with GC8.8 RULES FOR MEDIATION OF DISPUTES.
- 2) If a Project Mediator has not previously been appointed for the purposes of the Contract, a Project Mediator shall be appointed in accordance with GC8.8 RULES FOR MEDIATION OF DISPUTES forthwith after delivery of a notice in accordance with paragraph 3) of GC8.4 NEGOTIATION, requesting mediation.
- 3) If the dispute has not been resolved within
 - (a) Ten (10) working days following the appointment of a Project Mediator in accordance with paragraph 2) of GC8.5, if a Project Mediator was not previously appointed;
 - (b) Ten (10) working days following receipt by Canada of a written notice in accordance with paragraph 3) of GC8.4 NEGOTIATION, if a Project Mediator was previously appointed; or
 - (c) such other longer period as may have been agreed to by the parties;the Project Mediator shall terminate the mediation by giving written notice to the parties stating the effective date of termination.

GC8.6 CONFIDENTIALITY

- 1) All information exchanged during alternative dispute resolution procedures, by whatever means, shall be without prejudice and shall be treated as confidential by the parties and their representatives, unless otherwise required by law. However, evidence that is independently admissible or discoverable shall not be rendered inadmissible or non-discoverable by virtue of its use during an alternative dispute resolution process.

GC8.7 SETTLEMENT

- 1) Any agreement to settle all or any part of a dispute, by whatever means, shall be in writing and be signed by the parties or their authorized representatives.

GC8.8 RULES FOR MEDIATION OF DISPUTES

GC8.8.1 Interpretation

In these Rules

- 1) “Coordinator” means the person designated by Canada to act as the Dispute Resolution Coordinator.

GC8.8.2 Application

- 1) By mutual agreement, the parties may change or make additions to the Rules.

GC8.8.3 Communication

- 1) Written communications pursuant to these Rules shall be given in accordance with GC2.3 NOTICES.

GC8.8.4 Appointment of Project Mediator

- 1) The parties to the Contract may, by mutual consent, at any time after entry into the Contract, appoint a mediator (the "Project Mediator") to conduct mediation proceedings in accordance with these Rules for Mediation of Disputes, in regard to any dispute that may arise with regard to the interpretation, application or administration of the Contract. In this case, they shall jointly enter into a contract with the appointed Project Mediator, which contract shall be in a form drafted by the Coordinator and agreed to by the parties.
- 2) If the parties do not appoint a Project Mediator pursuant to paragraph 1) of GC8.8.4, the parties shall appoint a Project Mediator within 17 working days following receipt of a written notice from the Contractor, in accordance with GC2.3 NOTICES, requesting that mediated negotiations be undertaken in accordance with these Rules to assist the parties to reach agreement on any outstanding issues that may be in dispute. Any contract entered into with the appointed Project Mediator shall meet the requirements as set out for the contract described in paragraph 1) of GC8.8.4.
- 3) When mediation is requested by the Contractor pursuant to paragraph 3) of GC8.4 NEGOTIATION, if the parties have previously entered into a contract with a Project Mediator, the parties shall within 2 days send to both the Project Mediator and the Coordinator
 - (a) a copy of the notice requesting negotiation under paragraph 2) of GC8.3 NOTICE OF DISPUTE;
 - (b) a copy of Canada's written position in relation to the notice, the issues in contention and the relevant provisions of the contract; and
 - (c) a copy of the Contractor's written request for mediation required under paragraph 3) of GC8.4 NEGOTIATION.
- 4) If the parties have not agreed on a Project Mediator, the parties shall forthwith provide the Coordinator with the written materials referred to in subparagraphs 3)(a), 3)(b) and 3)(c) of GC8.8.4 together with a request that the Coordinator assist in the appointment of a mutually acceptable Project Mediator in accordance with these Rules.
- 5) Within 5 working days following receipt of the request and materials referred to in paragraph 4) of GC8.8.4, the Coordinator shall provide the parties with a list of qualified private sector mediators obtained from an independent and impartial entity, together with instructions to each party to individually and confidentially select and rank their preferred and fully acceptable choices of mediator in descending order. Each mediator listed shall be impartial and independent of the parties, and shall be an experienced and skilled commercial mediator, preferably with knowledge of the subject matter of the dispute.
- 6) Within 10 working days of receipt of the list referred to in paragraph 5) of GC8.8.4 each party shall comply with the instructions accompanying the list(s) and shall deliver the completed listing to the Coordinator.

- 7) Within 2 working days following receipt of the completed listings, the Coordinator shall select the highest common ranked mediator to act as Project Mediator for the purposes of the contract.
- 8) In the event of a tie, the Coordinator shall consult both parties to re-evaluate their rankings in order to assist the Coordinator in selecting a Project Mediator acceptable to both parties. If the parties cannot agree upon a Project Mediator, the Coordinator shall forthwith provide the parties with a second list of mediators and the procedure shall be repeated.
- 9) If the parties have not previously entered into a contract with a mutually acceptable Project Mediator, the Coordinator shall use reasonable efforts to negotiate a contract with a mutually acceptable Project Mediator on behalf of the parties, which contract shall incorporate or otherwise comply with the provisions of these Rules. If negotiations are unsuccessful, or if for other reason the individual is unwilling or unable to enter into a contract to act as Project Mediator, the Coordinator shall repeat the process with the second-highest common ranked mediator.
- 10) The parties agree that, upon successful completion of the negotiations referred to in paragraph 9) of GC8.8.4, they shall jointly enter into a contract with the selected Project Mediator, which contract shall be in a form drafted by the Coordinator and agreed to by the parties.
- 11) Upon execution of the contract with the Project Mediator referred to in paragraph 10) of GC8.8.4 the Coordinator shall provide the Project Mediator with copies of the documents referred to in paragraph 3) of GC8.8.4.

GC8.8.5 Confidentiality

- 1) Subject to paragraph 2) of GC8.8.5, and unless otherwise agreed in writing by the parties, the Project Mediator, the parties and their counsel or representatives shall keep confidential all matters and documents disclosed during mediation proceedings except where the disclosure is necessary for any implementation of any agreement reached or is required by law.
- 2) Evidence that is independently admissible or discoverable in any arbitral or judicial proceeding shall not be rendered inadmissible or non-discoverable by virtue of its use in mediation proceedings.
- 3) Neither party shall make transcripts, minutes or other records of a mediation conference.
- 4) The personal notes and written opinions of the Project Mediator made in relation to mediation are in the Project Mediator's sole possession and control, are confidential, and may not be used in any subsequent proceeding between the parties or where they are opposed in interest without the express written permission of the parties.
- 5) All information exchanged during mediation procedures, by whatever means, shall be without prejudice and shall be treated as confidential by the parties and their representatives, unless otherwise required by law.

GC8.8.6 Time and Place of Mediation

- 1) The Project Mediator, in consultation with the parties shall set the date, time and place of any mediation conference as soon as possible, bearing in mind that, subject to agreement to

the contrary between the parties, only 10 working days are available within which to attempt to settle the dispute.

GC8.8.7 Representation

- 1) Representatives of the parties may be accompanied at the mediation conference by legal counsel or any other person.
- 2) If the Project Mediator is a lawyer, the Project Mediator shall not provide legal advice to a party during the course of the mediation conference, but may recommend that a party obtain independent legal advice before finalizing a settlement agreement.

GC8.8.8 Procedure

- 1) The parties agree to an exchange of all facts, information and documents upon which they intend to rely in any oral or written presentation during the mediation. This exchange shall be completed no later than 2 working days prior to the date set for a mediation conference.
- 2) The Project Mediator shall be free to meet with the parties individually during a mediation conference if the Project Mediator is of the opinion that this may improve the chances of a mediated settlement, and either party may request such an individual meeting at any time.
- 3) The parties may agree to extend the 10 working days available for settlement of the dispute through mediation, and the Project Mediator shall record that agreement in writing.

GC8.8.9 Settlement Agreement

- 1) The parties shall record in writing any settlement agreement reached, with sufficient detail to ensure a clear understanding of
 - (a) the issues resolved;
 - (b) any obligations assumed by each party including criteria to determine if and when these obligations have been met; and
 - (c) the consequences of failure to comply with the agreement reached.
- 2) The parties agree to carry out the terms of a settlement agreement as soon as possible and, in any event, within any time periods specified in the agreement.

GC8.8.10 Termination of Mediation

- 1) Either party may withdraw from mediation at any time without reason and, in that event, the Project Mediator shall give each party a written notice terminating the mediation and establishing the effective date of termination.
- 2) If, in the opinion of the Project Mediator, either party fails to mediate in good faith or fails to comply with the terms of these Rules, or if the Project Mediator, at any time during mediation, is of the opinion that further negotiations will fail to resolve the issues outstanding, the Project Mediator may terminate the negotiations by providing the parties with a written notice of termination, stating therein the Project Mediator's reasons for the termination, and the effective date of termination.

- 3) If a dispute has not been resolved within 10 working days or such other longer period as may have been agreed to by the parties, the Project Mediator shall terminate the mediation by giving written notice to the parties stating the effective date of termination.

GC8.8.11 Costs

- 1) The parties agree that they will each be responsible for the costs of their own representatives and advisors and associated travel and living expenses. Fees and expenses of the Project Mediator and all administrative costs of mediation, such as the cost of the meeting room(s), if any, shall be borne equally by the parties.

GC8.8.12 Subsequent Proceedings

- 1) The parties shall not rely on or introduce as evidence in any arbitral or judicial proceeding, whether or not such proceeding relates to the subject matter of mediation,
 - (a) any documents of other parties that are not otherwise producible in those proceedings;
 - (b) any views expressed or suggestions made by any party in respect of a possible settlement of issues;
 - (c) any admission made by any party in the course of mediation unless otherwise stipulated by the admitting party; and
 - (d) the fact that any party has indicated a willingness to make or accept a proposal or recommendation for settlement.
- 2) The Project Mediator shall neither represent nor testify on behalf of either of the parties in any subsequent investigation, action or proceeding relating to the issues in mediation proceedings.
- 3) The Project Mediator shall not be subpoenaed to give evidence relating to
 - (a) the Project Mediator's role in mediation; or
 - (b) the matters or issues in mediation;in any subsequent investigation, action or proceeding and the parties agree to vigorously oppose any effort to have the Mediator so subpoenaed.

GC9 CONTRACT SECURITY

GC9.1 OBLIGATION TO PROVIDE CONTRACT SECURITY

GC9.2 TYPES AND AMOUNTS OF CONTRACT SECURITY

GC9.1 OBLIGATION TO PROVIDE CONTRACT SECURITY

- 1) The Contractor shall, at the Contractor's expense and within 14 days after the date that the Contractor receives notice that the Contractor's bid was accepted by Canada, obtain and deliver Contract Security to Canada in one of the forms prescribed in GC9.2 TYPES AND AMOUNTS OF CONTRACT SECURITY.
- 2) If the whole or a part of the Contract Security provided is in the form of a security deposit, it shall be held and disposed of in accordance with GC5.13 RETURN OF SECURITY DEPOSIT and GC7.4 SECURITY DEPOSIT - FORFEITURE OR RETURN.
- 3) If a part of the Contract Security provided is in the form of a labour and material payment bond, the Contractor shall post a copy of that bond at the site of the Work.
- 4) It is a condition precedent to the release of the first progress payment that the Contractor has provided the Contract Security as specified herein.

GC9.2 TYPES AND AMOUNTS OF CONTRACT SECURITY

- 1) The Contractor shall deliver to Canada either (a) or (b).
 - (a) A performance bond and a labour and material payment bond each in an amount that is equal to not less than 50 percent of the Contract Amount.
 - (b) A security deposit or an irrevocable standby letter of credit in an amount that is equal to not less than 20 percent of the Contract Amount.
- 2) A performance bond and a labour and material payment bond referred to in paragraph 1) of GC9.2 shall be in a form and be issued by a bonding or surety company that is approved by Canada.
 - (a) The approved form for the performance bond is displayed at the following Website:
<http://www.tbs-sct.gc.ca/pol/doc-eng.aspx?id=14494§ion=text#appS>
 - (b) The approved form for the labour and material payment bond is displayed at the following website: <http://www.tbs-sct.gc.ca/pol/doc-eng.aspx?id=14494§ion=text#appS>
; and
 - (c) The list of approved bonding or surety companies is displayed at the following Website:
<http://www.tbs-sct.gc.ca/pol/doc-eng.aspx?id=14494§ion=text#appL>
- 3) A security deposit referred to in subparagraph 1)(b) of GC9.2 shall be in the form of
 - (a) a bill of exchange, bank draft or money order made payable to the Receiver General for Canada and certified by an approved financial institution or drawn by an approved financial institution on itself; or

- (b) bonds of, or unconditionally guaranteed as to principal and interest by, the Government of Canada.
- 4) For the purposes of subparagraph 3)(a) of GC9.2
- (a) a bill of exchange is an unconditional order in writing signed by the Contractor and addressed to an approved financial institution, requiring the said institution to pay, on demand, at a fixed or determinable future time a sum certain of money to, or to the order of, the Receiver General for Canada;
 - (b) if a bill of exchange, bank draft or money order is certified by or drawn on an institution or corporation other than a chartered bank, it must be accompanied by proof that the said institution or corporation meets at least one of the criteria described in subparagraph 4)(c) of GC9.2, either by letter or by a stamped certification on the bill of exchange, bank draft or money; and
 - (c) An approved financial institution is
 - (i) a corporation or institution that is a member of the Canadian Payments Association as defined in the [Canadian Payments Act](#);
 - (ii) a corporation that accepts deposits that are insured, to the maximum permitted by law, by the Canada Deposit Insurance Corporation or the "Autorité des marchés financiers";
 - (iii) a corporation that accepts deposits from the public if repayment of the deposit is guaranteed by Her Majesty the Queen in right of a province;
 - (iv) a corporation, association or federation incorporated or organized as a credit union or co-operative credit society that conforms to the requirements of a credit union which are more particularly described in paragraph 137(6) of the [Income Tax Act](#); or
 - (v) Canada Post Corporation.
- 5) Bonds referred to in subparagraph 3)(b) of GC9.2 shall be provided on the basis of their market value current at the date of the Contract, and shall be
- (a) made payable to bearer; or
 - (b) accompanied by a duly executed instrument of transfer of the bonds to the Receiver General for Canada in the form prescribed by the Domestic Bonds of Canada Regulations; or
 - (c) registered as to principal, or as to principal and interest, in the name of the Receiver General for Canada pursuant to the Domestic Bonds of Canada Regulations.
- 6) An irrevocable standby letter of credit referred to in subparagraph 1)(b) of GC9.2 shall:
- (a) be an arrangement, however named or described, whereby a financial institution (the "Issuer") acting at the request and on the instructions of a customer (the "Applicant") or on its own behalf,
 - (i) is to make a payment to, or to the order of, Canada as the beneficiary;
 - (ii) is to accept and pay bills of exchange drawn by Canada;

- (iii) authorizes another financial institution to effect such payment or accept and pay such bills of exchange; or
 - (iv) authorizes another financial institution to negotiate against written demand(s) for payment provided that the terms and conditions of the letter of credit are complied with;
- (b) state the face amount that may be drawn against it;
 - (c) state its expiry date;
 - (d) provide for sight payment to the Receiver General for Canada by way of the financial institution's draft against presentation of a written demand for payment signed by Canada;
 - (e) provide that more than one written demand for payment may be presented subject to the sum of those demands not exceeding the face value of the letter of credit;
 - (f) provide that it is subject to the International Chamber of Commerce (ICC) Uniform Customs and Practice (UCP) for Documentary Credits, 2007 Revision, ICC Publication No. 600. Pursuant to the ICC UCP, a credit is irrevocable even if there is no indication to that effect; and
 - (g) be issued or confirmed, in either official language in a format left to the discretion of the issuer or confirmer, by an approved financial institution on its letterhead.

GC10 INSURANCE

GC10.1 INSURANCE CONTRACTS

GC10.2 INSURANCE PROCEEDS

GC10.1 INSURANCE CONTRACTS

- 1) The contractor shall, at the contractor's expense, obtain and maintain insurance contracts in respect of the work and shall provide evidence thereof to Canada in accordance with the requirements of the INSURANCE TERMS.
- 2) The insurance contracts referred to in paragraph 1) of GC10.1 shall
 - (a) be in a form, of the nature, in the amounts, for the periods and containing the terms and conditions specified in INSURANCE TERMS; and
 - (b) provide for the payment of claims under such insurance contracts in accordance with GC10.2 INSURANCE PROCEEDS.

GC10.2 INSURANCE PROCEEDS

- 1) In the case of a claim payable under a Builders Risk/Installation (All Risks) insurance contract maintained by the contractor pursuant to GC10.1 INSURANCE CONTRACTS, the proceeds of the claim shall be paid directly to Canada, and
 - (a) the monies so paid shall be held by Canada for the purposes of the contract, or
 - (b) if Canada elects, shall be retained by Canada, in which event they vest in Canada absolutely.
- 2) In the case of a claim payable under a General Liability insurance contract maintained by the contractor pursuant to GC10.1 INSURANCE CONTRACTS, the proceeds of the claim shall be paid by the insurer directly to the claimant.
- 3) If an election is made pursuant to paragraph 1) of GC10.2, Canada may cause an audit to be made of the accounts of the contractor and of Canada in respect of the part of the work that was lost, damaged or destroyed for the purpose of establishing the difference, if any, between
 - (a) the aggregate of the amount of the loss or damage suffered or sustained by Canada, including any costs incurred in respect of the clearing and cleaning of the work and its site and any other amount that is payable by the contractor to Canada under the contract, minus any monies retained pursuant to subparagraph 1)(b) of GC10.2; and
 - (b) the aggregate of the amounts payable by Canada to the contractor pursuant to the contract up to the date of the loss or damage.
- 4) A difference that is established pursuant to paragraph 3) of GC10.2 shall be paid forthwith by the party who is determined by the audit to be the debtor to the party who is determined by the audit to be the creditor.

- 5) When payment of a deficiency has been made pursuant to paragraph 4) of GC10.2, all rights and obligations of Canada and the contractor under the contract shall, with respect only to the part of the work that was the subject of the audit referred to in paragraph 3) of GC10.2, be deemed to have been expended and discharged.
- 6) If an election is not made pursuant to subparagraph 1)(b) of GC10.2, the contractor shall, subject to paragraph 7) of GC10.2, clear and clean the work and its site and restore and replace the part of the work that was lost, damaged or destroyed at the contractor's expense as if that part of the work had not yet been performed.
- 7) When the contractor clears and cleans the work and its site and restores and replaces the work referred to in paragraph 6) of GC10.2, Canada shall pay the contractor out of the monies referred to in paragraph 1) of GC10.2 so far as they will thereunto extend.
- 8) Subject to paragraph 7) of GC10.2, payment by Canada pursuant to paragraph 7) of GC10.2 shall be made in accordance with the contract but the amount of each payment shall be 100 percent of the amount claimed notwithstanding subparagraphs 3)(a) and 3)(b) of GC5.4 PROGRESS PAYMENT.



Agriculture and
Agri-Food Canada

Agriculture et
Agroalimentaire Canada

DRAWINGS AND SPECIFICATIONS

#14-1054

FOR

ROOF REPLACEMENT

Building 22

Project: MCE14-529452

CENTRAL EXPERIMENTAL FARM (CEF)

Agriculture and Agri-Food Canada (AAFC)

960 Carling Avenue

Ottawa, Ontario K1A 0C6

TABLE OF CONTENTS

SPECIFICATIONS

	Number of page
DIVISION 01 – General Requirements	
SECTION 01 10 20 General Instructions	8
SECTION 01 33 00 Submittal Procedures	4
SECTION 01 35 30 Health and Safety Requirements	3
SECTION 01 52 00 Construction Facilities	3
SECTION 01 77 00 Closeout Procedures	1
DIVISION 2 – Existing Conditions	
SECTION 02 41 13 Selective Site Demolition	5
DIVISION 6 – Wood, Plastic and Composites	
SECTION 06 10 00 Rough Carpentry	4
DIVISION 07 – Thermal and Moisture Protection	
SECTION 07 55 20 SBS Roof Concrete	11
SECTION 07 62 00 Metal Flashing and Trim	3
SECTION 07 92 00 Joint Sealing	5
DIVISION 23 – Heating, Ventilating, and Air Conditioning (HVAC)	
SECTION 23 05 01 Common Mechanical Work	3

DRAWINGS

1	Plan
2	Details
3	Details
Appendix E	Photographic Documentation

PART 1 - GENERAL

1.1 MINIMUM STANDARDS

- .1 Materials shall be new and work shall conform to the minimum applicable standards of the Canadian General Standards Board, the Canadian Standards Association, the National Building Code of Canada 2005 (NBC) and all applicable Provincial and Municipal codes. In the case of conflict or discrepancy the most stringent requirement shall apply.

1.2 SHOP DRAWINGS

- .1 Submit for the Project Manager's review, two copies of each shop drawing.
- .2 The review is for the sole purpose of ascertaining conformance with the general design concept, and does not mean approval of the design details inherent in the shop drawings, responsibility for which shall remain with the Contractor. Such review shall not relieve the Contractor of responsibility for errors or omissions in the shop drawings or of his responsibility for meeting all requirements of the Contract Documents.
- .3 Do not commence manufacture or order materials before shop drawings are reviewed by Project Officer.
- .4 The Contractor to review and sign the shop drawings prior to sending them to the Project Officer for review.

1.3 SAMPLES

- .1 Samples: examples of materials, equipment, quality, finishes, workmanship.
- .2 Where colour, pattern or texture is criterion, submit full range of samples.
- .3 Reviewed and accepted samples will become standard of workmanship and material against which installed work will be verified.

1.4 PRODUCT DATA

- .1 Product data: manufacturers catalogue sheets, brochures, literature, performance charts and diagrams, used to illustrate standard manufactured products.
- .2 Submit two copies of product data.
- .3 Delete information not applicable to project.
- .4 Cross-reference product data information to applicable portions of Contract Documents.

1.5 TAXES

- .1 Pay all taxes properly levied by law (including Federal, Provincial and Municipal).

1.6 FEES, PERMITS AND CERTIFICATES

- .1 Pay all fees and obtain all permits. Provide authorities with plans and information for acceptance certificates. Provide inspection certificates as evidence that work conforms to requirements of Authority having jurisdiction.

1.7 FIRE SAFETY REQUIREMENTS

- .1 Comply with the National Building Code of Canada 2005 (NBC) for fire safety in construction and the National Fire Code of Canada 2005 (NFC) for fire prevention, fire fighting and life safety in building in use.
- .2 Comply with Human Resources Development Canada (HRDC), Fire Commissioner of Canada (FCC) standards:
 - .1 No. 301: Standard for Construction / Operations
 - .2 No. 302: Standard for Welding and Cutting
 - .3 No. 374: Fire Protection Standard for General Storage (Indoor and Outdoor)
 - .4 These are available from Fire Protection Engineering Services, Labour Program, HRDC or following internet site:
<http://www.hrsdc.gc.ca/asp/gateway.asp?hr=en/lp/lo/fp/standards/commissioner.shtml&hs=fzp>
 - .5 Retain all fire safety documents and standards on site.
- .3 Welding and cutting:
 - .1 At least 48 hours prior to commencing cutting, welding or soldering procedure, provide to the Project Officer:
 - .1 Notice "of intent, "indicating devices affected, time and duration of isolation or bypass.
 - .2 Completed welding permit as defined in FC 302.
 - .3 Return welding permit to Project Officer immediately upon completion of procedures for which permit was issued.
 - .2 A fire watcher as described in FC 302 shall be assigned when welding or cutting operations are carried out in areas where combustible materials within 10m may be ignited by conduction or radiation.
- .4 Where work requires interruption of fire alarms or fire suppression, extinguishing or protection systems:
 - .1 Provide watchman ,service as described in FC 301; In general, watchman service is defined as an individual conversant with Fire Emergency Procedures, performing fire picket duty within an unprotected and unoccupied (no workers) area once per hour.
 - .2 Retain services of manufacturer for fire protection systems on daily basis or as approved by FCC, to isolate and protect all devices relating to:
 - .1 modification of fire alarms, fire suppression, extinguishing or protection systems; and/or
 - .2 cutting, welding, soldering or other construction activities which might activate fire protection systems.

- .5 Immediately upon completion of work, restore fire protection systems to normal operation and verify that all devices are fully operational.
- .6 Inform fire alarm system monitoring agency and local Fire Department immediately prior to isolation and immediately upon restoration of normal operation.

1.8 HAZARDOUS MATERIALS

- .1 Comply with the requirements of the Workplace Hazardous Materials Information System (WHMIS) regarding use, handling, storage, and disposal of hazardous materials; and regarding labelling and the provision of Material Safety Data Sheets (MSDS) acceptable to Human Resources Development Canada, Labour Program.
- .2 For work in occupied buildings give the Project Officer 48 hours notice for work involving designated substances (Ontario Bill 208), hazardous substances (Canada Labour Code Part II Section 10), and before painting, caulking, installing carpet or using adhesives.

1.9 TEMPORARY UTILITIES

- .1 Existing services required for the work, excluding power required for space heating, may be used by the Contractor without charge. Ensure capacity is adequate prior to imposing additional loads. Connect and disconnect at own expense and responsibility.
- .2 Connect to existing power supply in accordance with Canadian Electrical Code and provide meters and switching.
- .3 Notify the Project Officer and utility companies of intended interruption of services, obtain requisite permission.
- .4 Give the Project Officer 48 hours notice related to each necessary interruption of any mechanical or electrical service throughout the course of the work. Keep duration of these interruptions to a minimum. Carry out all interruptions after normal working hours of the occupants, preferably on weekends.

1.10 REMOVED MATERIALS

- .1 Unless otherwise specified, materials for removal become the Contractor's property and shall be taken from site.

1.11 PROTECTION

- .1 Protect finished work against damage until take-over.
- .2 Protect adjacent work against the spread of dust and dirt beyond the work areas.
- .3 Protect operatives and other users of site from all hazards.

1.12 USE OF SITE AND FACILITIES

- .1 Execute work with the least possible interference or disturbance to the normal use of premises. Make arrangements with the Project Officer to facilitate work as stated.
- .2 Maintain existing services to building and provide for personnel and vehicle access.

- .3 Where security is reduced by work provide temporary means to maintain security.
- .4 Where elevators, dumbwaiters, conveyors or escalators exist Contractor may use these at the Project Officer's discretion. Protect from damage, safety hazards and overloading of existing equipment.
- .5 Sanitary facilities will be assigned for Contractor's personnel. Others shall not be used. Keep facilities clean.
- .6 Closures: Protect work temporarily until permanent enclosures completed.

1.13 SITE STORAGE

- .1 The Project Manager will assign storage space which shall be equipped and maintained by the Contractor.
- .2 Do not unreasonably encumber site with materials or equipment.
- .3 Move stored products or equipment which interfere with operations of the Project Officer or other contractors.
- .4 Obtain and pay for use of additional storage or work areas needed for operations.

1.14 CUT, PATCH AND MAKE GOOD

- .1 Cut existing surfaces as required to accommodate new work.
- .2 Remove all items so shown or specified.
- .3 Patch and make good surfaces cut, damaged or disturbed, to the Project Officer 's approval. Match existing material, colour, finish and texture.
- .4 Install fire stops and smoke seals in accordance with ULC-SI15-1995 around pipe, ductwork, cables, and other objects penetrating fire separations to provide fire resistance not less than the fire resistance rating of surrounding floor, ceiling, and wall assembly.

1.15 SLEEVES, HANGERS AND INSERTS

- .1 Co-ordinate setting and packing of sleeves and supply and installation of hangers and inserts. Obtain the Project Officer's approval before cutting into structure.

1.16 SIGNS

- .1 Provide common-use signs related to traffic control, information, instruction, use of equipment, public safety devices, etc. in both official languages or by the use of commonly-understood graphic symbols to the Project Officer's approval.
- .2 No advertising will be permitted on this project.

1.17 ACCESS AND EGRESS

- .1 Design, construct and maintain temporary access to and egress from work areas, including stairs, runways, ramps or ladders and scaffolding, independent of finished surfaces and in accordance with relevant municipal, provincial and other regulations.

1.18 SCAFFOLDS AND WORK PLATFORMS

- .1 Design, install, and inspect scaffolds and work platforms required for work in accordance with relevant municipal, provincial and other regulations.

1.19 PUBLIC WAY PROTECTIONS

- .1 Design, erect and maintain hoarding to provide protection complete with signs as required by authority having jurisdiction.

1.20 OPERATIONS AND MAINTENANCE MANUALS

- .1 Two (2) weeks prior to any scheduled training, submit to the Project Manager two (2) copies of approved Operations Data and Maintenance Manual in both official languages, compiled as follows:

- .1 Bind data in vinyl hard cover 3 "D" ring type loose leaf binders for 212 x 275mm size paper. Binders must not exceed 75mm thick or be more than 2/3 full.
- .2 Enclose title sheet labelled "Operation Data and Maintenance Manual," project name, date and list of contents. Project name must appear on binder face and spine.
- .3 Organize contents into applicable sections of work to parallel project specifications breakdown. Mark each section by labelled tabs protected with celluloid covers fastened to hard paper dividing sheets.

- .2 Include following information plus data specified.

- .1 Maintenance instruction for finished surface and materials.
- .2 Copy of paint schedules.
- .3 Description: Operation of the equipment and systems defining start-up, shut-down and emergency procedures, and any fixed or adjustable set points that affect the efficiency of the operation. Include nameplate information such as make, size, capacity and serial number.
- .4 Maintenance: Use clear drawings, diagrams or manufacturers' literature which specifically apply and detail the following:
 - .1 lubrication products and schedules.
 - .2 trouble shooting procedures.
 - .3 adjustment techniques.
 - .4 operational checks.
 - .5 Suppliers names, addresses and telephone numbers and components supplied by them must be included in this section. Components must be identified by a description and manufacturers part number.
- .5 Guarantees showing:
 - .1 Name and address of projects.
 - .2 Guarantee commencement date (date of Interim Certificate of Completion).

- .3 Duration of guarantee.
 - .4 Clear indication of what is being guaranteed and what remedial action will be taken under guarantee.
 - .5 Signature and seal of Guarantor.
 - .6 Additional material used in project listed under various Sections showing name of manufacturer and source of supply.
- .3 Spare parts: List all recommended spares to be maintained on site to ensure optimum efficiency. List all special tools appropriate to unique application. All parts/tools detailed must be identified as to manufacturer, manufacturer part number and supplier (including address).
- .4 Include one complete set of final shop drawings (bound separately) indicating corrections and changes made during fabrication and installation.

1.21 RECORDS

- .1 As work progresses, maintain accurate records to show deviations from contract drawings. Just prior to the Project Officer's inspection for issuance of final certificate of completion, supply to the Project Officer one (1) set of white prints with all deviations neatly inked in. The Project Officer will provide two sets of clean white prints for this purpose.

1.22 GUARANTEES AND WARRANTIES

- .1 Before completion of work, collect all manufacturer's guarantees and warranties and deposit with Engineer.

1.23 CLEAN UP

- .1 Clean up work area as work progresses. At the end of each work period, and more often if ordered by the Project Officer, remove debris from site, neatly stack material for use, and clean up generally.
- .2 Upon completion remove scaffolding, temporary protection and surplus materials. Make good defects noted at this stage.
- .3 Wash and polish glass, stainless steel, baked or porcelain enamel, plastic laminate and other plastic surfaces, floors, hardware. Clean manufactured articles in accordance with manufacturer's directions.
- .4 Clean areas under contract to a condition at least equal to that previously existing and to approval of Project Officer.

1.24 CONTRACT DOCUMENTS

- .1 Drawings and specifications are complementary, items shown or mentioned in one and not in the other are deemed to be included in the contract work.

1.25 BUILDING SMOKING ENVIRONMENT

- .1 Smoking is not permitted in the Building. Obey smoking restrictions on building property.

1.26 DUST CONTROL

- .1 Provide dust tight screens or partitions to localize dust generating activities, and for protection of workers, finished areas of work and public.
- .2 Maintain and relocate protection until such work is complete.
- .3 Protect all furnishings within work area with 0.102 mm thick polyethylene film during construction. Remove film during non-construction hours and leave premises in clean, unencumbered and safe manner for normal daytime function.

1.27 TESTING LABORATORY

- .1 The Project Manager will appoint and pay for costs of inspection and testing services, unless indicated otherwise.
- .2 Provide safe working areas and assist with testing procedures, including provisions for materials or services and co-ordination, as required by testing agency and as authorized by Project Officer.
- .3 Where tests indicate non-compliance with specifications, contractor to pay for initial test and all subsequent testing of work to verify acceptability of corrected work.

1.28 SCHEDULING

- .1 On award of contract submit bar chart construction schedule for work, indicating anticipated progress stages within time of completion. When schedule has been reviewed by the Project Manager, take necessary measures to complete work within scheduled time. Do not change schedule without notifying the Project Manager.
- .2 Carry -out work between 7:00 and 18:00 Monday to Friday, excluding statutory holidays. Work overtime hours as required to meet the scheduled completion date.
- .3 Give the Project Officer 48 hours notice for work to be carried out on between 18:00 and 7:00 hours and for work to be carried out on weekends or holidays.
- .4 Carry out noise generating work during "off hours" Monday to Friday from 16:00 to 09:00 hours and on Saturdays, Sundays, and statutory holidays.

1.29 COST BREAKDOWN

- .1 Five days after Contract award and before submitting first progress claim, submit breakdown of Contract Amount in detail for the Project Officer's approval and aggregating the Contract Amount. After approval by the Project Officer, the cost breakdown will be used as the basis of progress payments.

PART 2 – PRODUCTS

2.1 Not used

PART 3 – EXECUTION

3.1 Not used

END OF SECTION 01 10 20

Part 1 GENERAL

1.1 ADMINISTRATIVE

- .1 Submit to the Consultant submittals listed for review. Submit promptly and in orderly sequence to not cause delay in Work. Failure to submit in ample time is not considered sufficient reason for extension of Contract Time and no claim for extension by reason of such default will be allowed.
- .2 Do not proceed with Work affected by submittal until review is complete.
- .3 Present shop drawings, product data, samples and mock-ups in SI Metric units.
- .4 Where items or information is not produced in SI Metric units converted values are acceptable.
- .5 Review submittals prior to submission to the Consultant. This review represents that necessary requirements have been determined and verified, or will be, and that each submittal has been checked and co-ordinated with requirements of Work and Contract Documents. Submittals not stamped, signed, dated and identified as to specific project will be returned without being examined and considered rejected.
- .6 Verify field measurements and affected adjacent Work are co-ordinated.
- .7 Contractor's responsibility for errors and omissions in submission is not relieved by the Consultant, review of submittals.
- .8 Contractor's responsibility for deviations in submission from requirements of Contract Documents is not relieved by the Consultant's review.
- .9 Keep one reviewed copy of each submission on site.

1.2 SHOP DRAWINGS AND PRODUCT DATA

- .1 The term "shop drawings" means drawings, diagrams, illustrations, schedules, performance charts, brochures and other data which are to be provided by Contractor to illustrate details of a portion of Work.
- .2 Indicate materials, methods of construction and attachment or anchorage, erection diagrams, connections, explanatory notes and other information necessary for completion of Work. Where articles or equipment attach or connect to other articles or equipment, indicate that such items have been co-ordinated, regardless of Section under which adjacent items will be supplied and installed. Indicate cross references to design drawings and specifications.
- .3 Allow five (5) days for the Consultant's review of each submission.
- .4 Adjustments made on shop drawings by the Consultant are not intended to change Contract Price. If adjustments affect value of Work, state such in writing to the Consultant, prior to proceeding with Work.
- .5 Make changes in shop drawings the Consultant may require, consistent with Contract Documents. When resubmitting, notify the Consultant in writing of revisions other than those requested.
- .6 Accompany submissions with transmittal letter, in duplicate, containing:
 - .1 Date,
 - .2 Project title and number,
 - .3 Contractor's name and address,
 - .4 Identification and quantity of each shop drawing, product data and sample,
 - .5 Other pertinent data.
- .7 Submissions include:

- .1 Date and revision dates,
- .2 Project title and number.
- .3 Name and address of:
 - .1 Subcontractor,
 - .2 Supplier,
 - .3 Manufacturer.
- .4 Contractor's stamp, signed by Contractor's authorized representative certifying approval of submissions, verification of field measurements and compliance with Contract Documents.
- .5 Details of appropriate portions of Work as applicable:
 - .1 Fabrication,
 - .2 Layout, showing dimensions, including identified field dimensions, and clearances,
 - .3 Setting or erection details,
 - .4 Capacities,
 - .5 Performance characteristics,
 - .6 Standards,
 - .7 Operating weight,
 - .8 Wiring diagrams,
 - .9 Single line and schematic diagrams,
 - .10 Relationship to adjacent work.
- .8 After the Consultant's review and written acceptance, distribute copies.
- .9 Submit pdf files of shop drawings for each requirement requested in specification Sections and as the Consultant may reasonably request.
- .10 Submit pdf files of product data sheets or brochures for requirements requested in specification Sections and as requested by the Consultant where shop drawings will not be prepared due to standardized manufacture of product.
- .11 Submit pdf files of test reports for requirements requested in specification Sections and as requested by the Consultant.
 - .1 Report signed by authorized official of testing laboratory that material, product or system identical to material, product or system to be provided has been tested in accord with specified requirements.
 - .2 Testing must have been within three (3) years of date of contract award for project.
- .12 Submit pdf files of certificates for requirements requested in specification Sections and as requested by the Consultant.
 - .1 Statements printed on manufacturer's letterhead and signed by responsible officials of manufacturer of product, system or material attesting that product, system or material meets specification requirements.
 - .2 Certificates must be dated after award of project contract complete with project name.
- .13 Submit electronic copies of manufacturer's instructions for requirements requested in specification Sections and as requested by the Consultant.
 - .1 Pre-printed material describing installation of product, system or material, including special notices and Material Safety Data Sheets concerning impedances, hazards and safety precautions.

- .14 Submit electronic copies of Manufacturer's Field Reports for requirements requested in specification Sections and as requested by Consultant.
- .15 Submit electronic copies of Operation and Maintenance Data for requirements requested in specification Sections and as requested by Consultant.
- .16 Supplement standard information to provide details applicable to project.
- .17 If upon review by the Consultant, no errors or omissions are discovered or if only minor corrections are made, copies will be returned and fabrication and installation of Work may proceed. If shop drawings are rejected, noted copy will be returned and resubmission of corrected shop drawings, through same procedure indicated above, must be performed before fabrication and installation of Work may proceed.
- .18 The review of shop drawings by is for sole purpose of ascertaining conformance with general concept.
 - .1 This review shall not mean that the Owner or Consultant approves detail design inherent in shop drawings, responsibility for which shall remain with Contractor submitting same, and such review shall not relieve Contractor of responsibility for errors or omissions in shop drawings or of responsibility for meeting requirements of construction and Contract Documents.
 - .2 Without restricting generality of foregoing, Contractor is responsible for dimensions to be confirmed and correlated at job site, for information that pertains solely to fabrication processes or to techniques of construction and installation and for co-ordination of Work of sub-trades.

1.3 SAMPLES

- .1 Submit for review samples in duplicate as requested in respective specification Sections. Label samples with origin and intended use.
- .2 Deliver samples prepaid to the Consultant's business address.
- .3 Notify the Consultant in writing, at time of submission of deviations in samples from requirements of Contract Documents.
- .4 Where colour, pattern or texture is criterion, submit full range of samples.
- .5 Adjustments made on samples by the Consultant are not intended to change Contract Price. If adjustments affect value of Work, state such in writing to the CEF Representative prior to proceeding with Work.
- .6 Make changes in samples which the Consultant may require, consistent with Contract Documents.
- .7 Reviewed and accepted samples will become standard of workmanship and material against which installed Work will be verified.

1.4 PHOTOGRAPHIC DOCUMENTATION

- .1 Submit electronic copy of digital photography in jpg format, standard resolution with progress statement, or as directed by the Consultant.
- .2 Project identification: name and number of project and date of exposure indicated.
- .3 Frequency of photographic documentation: weekly as directed by the Consultant.

1.5 CERTIFICATES AND TRANSCRIPTS

- .1 Immediately after award of Contract, submit Workers' Compensation Board status.

Part 2	PRODUCTS
2.1	Not used
Part 3	EXECUTION
3.1	Not used

END OF SECTION 01 33 00

Part 1 General

1.1 REFERENCES

- .1 Canada Labour Code, Part 2, Canada Occupational Safety and Health Regulations
- .2 Health Canada/Workplace Hazardous Materials Information System (WHMIS)
 - .1 Material Safety Data Sheets (MSDS).
- .3 Province of Ontario
 - .1 Occupational Health and Safety Act, R.S.O. [1990 Updated 2005].

1.2 SUBMITTALS

- .1 Make submittals in accordance with Section 01 33 00 - Submittal Procedures.
- .2 Submit site-specific Health and Safety Plan: Within seven (7 days after date of Notice to Proceed and prior to commencement of Work. Health and Safety Plan must include:
 - .1 Results of site specific safety hazard assessment.
 - .2 Results of task specific safety hazard assessment.
- .3 Submit two (2) copies of Contractor's authorized representative's work site health and safety inspection reports to the Consultant and/or authority having jurisdiction.
- .4 Submit copies of reports or directions issued by Federal, Provincial and Territorial health and safety inspectors.
- .5 Submit copies of incident and accident reports.
- .6 Submit WHMIS MSDS - Material Safety Data Sheets.
- .7 The Consultant will review Contractor's site-specific Health and Safety Plan and provide comments to Contractor within 7 days after receipt of plan. Revise plan as appropriate and resubmit plan to the Consultant within 7 days after receipt of comments from the Consultant.
- .8 The Consultant's review of Contractor's final Health and Safety plan should not be construed as approval and does not reduce the Contractor's overall responsibility for construction Health and Safety.
- .9 Medical Surveillance: where prescribed by legislation, regulation or safety program, submit certification of medical surveillance for site personnel prior to commencement of Work, and submit additional certifications for any new site personnel to the Consultant .
- .10 Emergency Response Plan: Submit emergency response procedures in the event of a site emergency

1.3 FILING OF NOTICE

- .1 File Notice of Project with Provincial authorities prior to beginning of Work.

1.4 SAFETY ASSESSMENT

- .1 Perform site specific safety hazard assessment related to project.

1.5 MEETINGS

- .1 Schedule and administer Health and Safety meeting with the Consultant prior to commencement of Work.

1.6 RESPONSIBILITY

- .1 Be responsible for health and safety of persons on site, safety of property on site and for protection of persons adjacent to site and environment to extent that they may be affected by conduct of Work.
- .2 Comply with and enforce compliance by employees with safety requirements of Contract Documents, applicable federal, provincial, territorial and local statutes, regulations, and ordinances, and with site-specific Health and Safety Plan.

1.7 COMPLIANCE REQUIREMENTS

- .1 Comply with Workers Compensation Act.
- .2 Comply with Ontario Health and Safety Act, R.S.O.
- .3 Comply with Occupational Health and Safety Regulations, 1996.
- .4 Comply with Canada Labour Code, Canada Occupational Safety and Health Regulations.

1.8 UNFORSEEN HAZARDS

- .1 When unforeseen or peculiar safety-related factor, hazard, or condition occur during performance of Work, follow procedures in place for Employee's Right to Refuse Work in accordance with Acts and Regulations of Province having jurisdiction and advise the Consultant verbally and in writing.

1.9 HEALTH AND SAFETY CO-ORDINATOR

- .1 Employ and assign to Work, competent and authorized representative as Health and Safety Co-ordinator. Health and Safety Co-ordinator must:
 - .1 Have working knowledge of occupational safety and health regulations.
 - .2 Be responsible for completing Contractor's Health and Safety Training Sessions and ensuring that personnel not successfully completing required training are not permitted to enter site to perform Work.
 - .3 Be responsible for implementing, enforcing daily and monitoring site-specific Contractor's Health and Safety Plan.

1.10 POSTING OF DOCUMENTS

- .1 Ensure applicable items, articles, notices and orders are posted in conspicuous location on site in accordance with Acts and Regulations of Province having jurisdiction, and in consultation with the Consultant.

1.11 CORRECTION OF NON-COMPLIANCE

- .1 Immediately address health and safety non-compliance issues identified by authority having jurisdiction or by the Consultant.
- .2 Provide the Consultant with written report of action taken to correct non-compliance of health and safety issues identified.
- .3 The Consultant may stop Work if non-compliance of health and safety regulations is not corrected.

1.12 WORK STOPPAGE

- .1 Give precedence to safety and health of public and site personnel and protection of environment over cost and schedule considerations for Work.

Part 2 Products

2.1 NOT USED

Part 3 Execution

3.1 NOT USED

END OF SECTION 01 35 30

Part 1 General

1.1 REFERENCES

- .1 Canadian Construction Documents Committee (CCDC)
 - .1 CCDC 2-[1994], Stipulated Price Contract.
 - .2 CAN/CSA-S269.2-[M1987(R2003)], Access Scaffolding for Construction Purposes.
 - .3 CAN/CSA-Z321-[96(R2001)], Signs and Symbols for the Occupational Environment.

1.2 SUBMITTALS

- .1 Provide submittals in accordance with Section 01 33 00 - Submittal Procedures.
- .2 Prepare site plan indicating proposed location and dimensions of area to be fenced and used by Contractor, avenues of ingress/egress to fenced area and details of fence installation.
- .3 Indicate use of supplemental or other staging area.
- .4 Provide construction facilities in order to execute work expeditiously.
- .5 Remove from site all such work after use.

1.3 SCAFFOLDING

- .1 Scaffolding in accordance with CAN/CSA-S269.2.
- .2 Provide and maintain scaffolding, ramps, ladders, swing staging, platforms and temporary stairs as required.

1.4 HOISTING

- .1 Provide, operate and maintain hoists, cranes required for moving of workers, materials and equipment
- .2 Hoists, cranes to be operated by qualified operator.

1.5 SITE STORAGE/LOADING

- .1 Confine work and operations of employees by Contract Documents. Do not unreasonably encumber premises with products.
- .2 Do not load or permit to load any part of Work with weight or force that will endanger Work.

1.6 CONSTRUCTION PARKING

- .1 Parking will be permitted on site provided it does not disrupt performance of Work or building operations.
- .2 Provide and maintain adequate access to project site.

1.7 EQUIPMENT, TOOL AND MATERIALS STORAGE

- .1 Provide and maintain, in clean and orderly condition, lockable weatherproof sheds for storage of tools, equipment and materials.
- .2 Locate materials not required to be stored in weatherproof sheds on site in manner to cause least interference with work activities.

1.8 SANITARY FACILITIES

- .1 Provide sanitary facilities for work force in accordance with governing regulations and ordinances.
- .2 Post notices and take precautions as required by local health authorities. Keep area and premises in sanitary condition.

1.9 CONSTRUCTION SIGNAGE

- .1 No signs or advertisements, other than warning signs, are permitted on site.
- .2 Signs and notices for safety and instruction in both official languages Graphic symbols to CAN/CSA-Z321.
- .3 Maintain approved signs and notices in good condition for duration of project, and dispose of off site on completion of project or earlier if directed by Consultant.

1.10 PROTECTION AND MAINTENANCE OF TRAFFIC

- .1 Provide access and temporary relocated roads as necessary to maintain traffic.
- .2 Protect travelling public from damage to person and property.
- .3 Contractor's traffic on roads selected for hauling material to and from site to interfere as little as possible with public traffic.
- .4 Verify adequacy of existing roads and allowable load limit on these roads. Contractor: responsible for repair of damage to roads caused by construction operations.

1.11 CLEAN-UP

- .1 Remove construction debris, waste materials, packaging material from work site daily.
- .2 Store materials resulting from demolition activities that are salvageable.
- .3 Stack stored new or salvaged material not in construction facilities.

Part 2 Products

2.1 NOT USED

Part 3 Execution

3.1 NOT USED

END OF SECTION 01 52 00

Part 1 General

1.1 ADMINISTRATIVE REQUIREMENTS

- .1 Contractor's Inspection: Contractor - conducts inspection of Work, identify deficiencies and defects, and repair as required to conform to Contract Documents.
 - .1 Notify the Consultant in writing of satisfactory completion of Contractor's inspection and submit verification that corrections have been made.
 - .2 Request the Consultant's inspection.
- .2 The Consultant's Inspection:
 - .1 The Consultant and Contractor to inspect Work and identify defects and deficiencies.
 - .2 Contractor to correct Work as directed.
- .3 Completion Tasks: submit written certificates in English that tasks have been performed as follows:
 - .1 Work: completed and inspected for compliance with Contract Documents.
 - .2 Defects: corrected and deficiencies completed.
 - .3 Work: complete and ready for final inspection.
- .4 Final Inspection:
 - .1 When completion tasks are done, request final inspection of Work by the Consultant and Contractor.
 - .2 When Work incomplete according to Owner and the Consultant, complete outstanding items and request re-inspection.
- .5 Declaration of Substantial Performance: when the Consultant considers deficiencies and defects corrected and requirements of Contract substantially performed, make application for Certificate of Substantial Performance.
- .6 Commencement of Lien and Warranty Periods: date of Owner's acceptance of submitted declaration of Substantial Performance to be date for commencement for warranty period and commencement of lien period unless required otherwise by lien statute of Place of Work.
- .7 Final Payment:
 - .1 When the Consultant considers final deficiencies and defects corrected and requirements of Contract met, make application for final payment.
 - .2 Refer to CCDC 2 when Work deemed incomplete by the Consultant, complete outstanding items and request re-inspection.

Part 2 Products

2.1 NOT USED

Part 3 Execution

3.1 NOT USED

Part 1 General

1.1 SCOPE OF WORK

- .1 Provide all labour, Products, equipment and services necessary to perform the demolition, removal and disposal work specified in this Section and in accordance with the Specifications.
- .2 This section specifies the work associated with the removal of the existing roof assemblies, including the removal and disposal of any areas of damaged or de-bonded membranes fully adhered to concrete, insulation, ballast, metal flashings, and all accessories.
- .3 Remove and reinstate all HVAC equipment as identified on roof plan and section details to allow completion of roofing work as specified.

1.2 REFERENCES

- .1 Definitions:
 - .1 Demolition: rapid destruction of building following removal of hazardous materials.
 - .2 Hazardous Materials: dangerous substances, dangerous goods, hazardous commodities and hazardous products, may include but not limited to: asbestos PCB's, CFC's, HCFC's poisons, corrosive agents, flammable substances, ammunition, explosives, radioactive substances, or other material that can endanger human health or well being or environment if handled improperly.
 - .3 Waste Audit (WA): detailed inventory of materials in building. Indicates quantities of reuse, recycling and landfill.
 - .1 Involves quantifying by volume/weight amounts of materials and wastes generated during construction, demolition, deconstruction, or renovation project.
 - .2 Indicates quantities of reuse, recycling and landfill.
 - .4 Waste Management Coordinator (WMC): contractor representative responsible for supervising waste management activities as well as coordinating related, required submittal and reporting requirements.
 - .5 Waste Reduction Workplan (WRW): written report which addresses opportunities for reduction, reuse, or recycling of materials. WRW is based on information acquired from WA.
- .2 Reference Standards:
 - .1 Health Canada/Workplace Hazardous Materials Information System (WHMIS)
 - .1 Material Safety Data Sheets (MSDS).
 - .2 Transport Canada (TC)
 - .1 Transportation of Dangerous Goods Act, 1992 (TDGA), c. 34.

1.3 ADMINISTRATIVE REQUIREMENTS

- .1 Site Meetings.
 - .1 Convene pre-demolition meeting one week prior to beginning to:
 - .1 Verify project requirements.

- .2 Review installation and substrate conditions.
- .3 Co-ordination with other building subtrades.
- .4 Review manufacturer's installation instructions and warranty requirements.
- .2 Arrange for site visit with Consultant to examine existing site conditions adjacent to demolition work, prior to start of Work.
- .3 Hold project meetings every month.
- .4 Ensure key personnel, site supervisor, project manager, subcontractor representatives attend.
- .5 Consultant will provide written notification of change of meeting schedule established upon contract award 24 hours prior to scheduled meeting.
- .2 Scheduling: meet project time lines without compromising minimum rates of material diversion.
 - .1 Notify Consultant in writing when unforeseen delays occur.

1.4 ACTION AND INFORMATIONAL SUBMITTALS

- .1 Submit in accordance with Section 01 33 00 - Submittal Procedures.
- .2 Shop Drawings:
 - .1 Submit drawings stamped and signed by professional engineer registered or licensed in the Province of the Work.
 - .2 Submit for approval drawings, diagrams or details showing sequence of demolition work and supporting structures and underpinning, where required by authorities having jurisdiction.
- .3 Hazardous Materials:
 - .1 Provide description of Hazardous Materials and Notification of Filing with proper authorities prior to beginning of Work as required.
- .4 Certificates:
 - .1 Submit copies of certified receipts from authorized disposal sites and reuse and recycling facilities for material removed from site upon request of Consultant.
 - .2 Written authorization Consultant is required to deviate from haulers and facilities listed in Waste Reduction Workplan.

1.5 QUALITY ASSURANCE

- .1 Regulatory Requirements: ensure Work is performed in compliance with applicable Provincial/Territorial regulations.

1.6 DELIVERY, STORAGE AND HANDLING

- .1 Store and manage hazardous materials in accordance with Section applicable regulations.
- .2 Storage and Protection.

- .1 Protect existing items designated to remain and items designated for salvage. In event of damage to such items, immediately replace or make repairs to approval of Consultant and at no cost to Owner. These items include but are not limited to:
 - .1 Gas lines
 - .2 HVAC equipment
 - .3 Exhaust fans and other mechanical equipment on rooftop
 - .4 Satellite Dish or other communications equipment
- .2 Remove and store materials to be salvaged, in manner to prevent damage.
- .3 Store and protect in accordance with requirements for maximum preservation of material.
- .4 Handle salvaged materials as new materials.

1.7 SITE CONDITIONS

- .1 Site Environmental Requirements.
 - .1 Ensure that selective demolition work does not adversely affect adjacent watercourses, groundwater and wildlife, or contribute to excess air and noise pollution.
 - .2 Do not dispose of waste of volatile materials including but not limited to, mineral spirits, oil, petroleum based lubricants, or toxic cleaning solutions into watercourses, storm or sanitary sewers.
 - .1 Ensure proper disposal procedures are maintained throughout the project.
 - .3 Do not pump water containing suspended materials into watercourses, storm or sanitary sewers or onto adjacent properties.
 - .4 Control disposal or runoff of water containing suspended materials or other harmful substances in accordance with local authorities.
 - .5 Protect trees, plants and foliage on site and adjacent properties where indicated.
- .2 Existing Conditions.
 - .1 Remove contaminated or hazardous materials as defined by authorities having jurisdiction from site, prior to start of demolition Work, and dispose of at designated disposal facilities in safe manner in accordance with TDGA and other applicable regulatory requirements.
 - .2 List of hazardous materials:
 - .1 See Owners Hazardous material report for this site, to be provided upon request

Part 2 Products

2.1 EQUIPMENT

- .1 Leave machinery running only while in use, except where extreme temperatures prohibit shutting machinery down.

Part 3 Execution

3.1 PREPARATION

- .1 Inspect site with Consultant and verify extent and location of items designated for removal, disposal, alternative disposal, recycling, salvage and items to remain.
- .2 Locate and protect utilities. Preserve active utilities traversing site in operating condition.
- .3 Notify and obtain approval of utility companies before starting demolition.
- .4 Disconnect and Reconnect Mechanical Services as required to complete work.
 - .1 Natural Gas Supply Lines: contact utility company to arrange for shutoff as required.
- .5 Install temporary plugs in roof drains during removals to prevent accumulation of waste and debris in rainwater leaders. Flush drains upon completion of roofing work.
- .6 Identify overhead or nearby electrical wires. Protect or disconnect as required to permit work

3.2 REMOVAL OF HAZARDOUS WASTES

- .1 Remove contaminated or dangerous materials defined by authorities having jurisdiction, relating to environmental protection, from site and dispose of in safe manner to minimize danger at site or during disposal.

3.3 REMOVAL OPERATIONS

- .1 Remove items as indicated.
- .2 Do not disturb roof areas designated to remain in place.
- .3 Where areas of roofing are to remain, but must be used as storage or to provide access to the work area, protect existing roofing with plywood as required. Restore existing roofing to original condition or better.
- .4 Remove tree branches as required during demolition.
 - .1 Obtain written approval of Consultant prior to removal of tree branches designated.
- .5 Salvage:
 - .1 Gravel ballast
 - .2 Identified insulation
 - .3 Perform removals to protect items for salvage and stockpile salvaged materials at locations as approved by Consultant.
- .6 Disposal of Material:
 - .1 Dispose of materials not designated for salvage or reuse on site at authorized facilities approved by Consultant.

3.4 STOCKPILING

- .1 Label stockpiles, indicating material type and quantity.

- .2 Designate appropriate security resources/measures to prevent vandalism, damage and theft.
- .3 Locate stockpiled materials convenient for use in new construction to eliminate double handling wherever possible.
- .4 Stockpile materials designated for alternate disposal in location which facilitates removal from site and examination by potential end markets, and which does not impede disassembly, processing, or hauling procedures.

3.5 REMOVAL FROM SITE

- .1 Remove stockpiled material as directed by Consultant, when it interferes with operations of project.
- .2 Remove stockpiles of like materials by alternate disposal option once collection of materials is complete.
- .3 Dispose of materials not designated for alternate disposal in accordance with applicable regulations.

3.6 RESTORATION

- .1 Restore areas and existing works outside areas of demolition to conditions that existed prior to beginning of Work, and to match condition of adjacent, undisturbed areas.
- .2 Use soil treatments and procedures which are not harmful to health, are not injurious to plants, and do not endanger wildlife, adjacent water courses or ground water.

3.7 CLEANING

- .1 Progress Cleaning:
 - .1 Leave Work area clean at end of each day.
 - .2 Remove debris, trim surfaces and leave work site clean, upon completion of Work
 - .3 Use cleaning solutions and procedures which are not harmful to health, are not injurious to plants, and do not endanger wildlife, adjacent water courses or ground water.
- .2 Final Cleaning: upon completion remove surplus materials, rubbish, tools and equipment

3.8 PROTECTION

- .1 Repair damage to adjacent materials or property caused by selective site demolition.

END OF SECTION

Part 1 General

1.1 REFERENCES

- .1 ASTM International
 - .1 ASTM A123/A123M-09, Standard Specification for Zinc (Hot-Dip Galvanized) Coatings on Iron and Steel Products.
 - .2 ASTM A653/A653M-11, Standard Specification for Steel Sheet, Zinc-Coated (Galvanized) or Zinc-Iron Alloy-Coated (Galvanealed) by the Hot-Dip Process.
- .2 Canadian General Standards Board (CGSB)
 - .1 CAN/CGSB-11.3-M87, Hardboard.
- .3 CSA International
 - .1 CSA B111-1974(R2003), Wire Nails, Spikes and Staples.
 - .2 CSA O121-08, Douglas Fir Plywood.
 - .3 CSA O141-05(R2009), Softwood Lumber.
 - .4 CSA O151-09, Canadian Softwood Plywood.
 - .5 CAN/CSA-Z809-08, Sustainable Forest Management.
- .4 Forest Stewardship Council (FSC)
 - .1 FSC-STD-01-001-2004, FSC Principle and Criteria for Forest Stewardship.
- .5 National Lumber Grades Authority (NLGA)
 - .1 Standard Grading Rules for Canadian Lumber 2010.

1.2 QUALITY ASSURANCE

- .1 Lumber by grade stamp of an agency certified by Canadian Lumber Standards Accreditation Board.
- .2 Plywood, particleboard, OSB and wood based composite panels in accordance with CSA and ANSI standards.
- .3 Sustainable Standards Certification:
 - .1 Certified Wood: submit listing of wood products and materials used in accordance with CAN/CSA-Z809 or FSC or SFI.

1.3 DELIVERY, STORAGE AND HANDLING

- .1 Deliver, store and handle materials in accordance with manufacturer's written instructions.
- .2 Delivery and Acceptance Requirements: deliver materials to site in original factory packaging, labelled with manufacturer's name and address.
- .3 Storage and Handling Requirements:
 - .1 Store materials off ground, in dry location, and in accordance with manufacturer's recommendations in clean, dry, well-ventilated area.

- .2 Store and protect wood from nicks, scratches, and blemishes.
- .3 Replace defective or damaged materials with new.

Part 2 Products

2.1 FRAMING STRUCTURAL AND PANEL MATERIALS

- .1 Description:
 - .1 Sustainability Characteristics:
 - .1 Lumber, CAN/CSA-Z809 or FSC or SFI certified.
 - .2 Plywood, urea-formaldehyde free, CAN/CSA-Z809 or FSC certified.
 - .2 Lumber: softwood, S4S, moisture content 19% (S-dry) or less in accordance with following standards:
 - .1 CSA O141.
 - .2 NLGA Standard Grading Rules for Canadian Lumber.
 - .3 Furring, blocking, nailing strips, grounds, rough bucks, cants, curbs, fascia backing and sleepers:
 - .1 S2S is acceptable for Furring, blocking, nailing strips, grounds, rough bucks, cants, curbs, fascia backing and sleepers.
 - .2 Board sizes: "Standard" or better grade.
 - .3 Dimension sizes: "Standard" light framing or better grade.
 - .4 Post and timbers sizes: "Standard" or better grade.
 - .4 Plywood, OSB and wood based composite panels: to CSA O325.
 - .5 Douglas fir plywood (DFP): to CSA O121, standard construction.
 - .6 Canadian softwood plywood (CSP): to CSA O151, standard construction.

2.2 ACCESSORIES

- .1 Nails, spikes and staples: to CSA B111.
- .2 Bolts: 12.5 mm diameter unless indicated otherwise, complete with nuts and washers.
- .3 Proprietary fasteners: toggle bolts, expansion shields and lag bolts, screws and lead or inorganic fibre plugs, explosive actuated fastening devices, recommended for purpose by manufacturer.
- .4 Roof sheathing H-Clips: formed "H" shape, thickness to suit panel material, extruded 6063-T6 aluminum alloy type approved by Consultant.
- .5 Fastener Finishes:
 - .1 Galvanizing: to ASTM A653, use galvanized fasteners for exterior work and pressure-treated lumber.

Part 3 Execution

3.1 EXAMINATION

- .1 Verification of Conditions: verify conditions of substrates previously installed under other Sections or Contracts are acceptable for product installation in accordance with manufacturer's written instructions.
 - .1 Visually inspect substrate in presence of AAFC Representative and Consultant.
 - .2 Inform AAFC Representative and Consultant of unacceptable conditions immediately upon discovery.
 - .3 Proceed with installation only after unacceptable conditions have been remedied and after receipt of written approval to proceed from AAFC Representative and Consultant.

3.2 MATERIAL USAGE

- .1 Roof sheathing:
 - .1 Plywood, DFP or CSP sheathing grade or PP standard sheathing grade, square edge, 15.5 mm thick, or to match existing.

3.3 INSTALLATION

- .1 Install members true to line, levels and elevations, square and plumb.
- .2 Construct continuous members from pieces of longest practical length.
- .3 Install spanning members with "crown-edge" up.
- .4 Install roof sheathing in accordance with requirements of NBC.
- .5 Install furring and blocking as required to space-out and support casework, cabinets, wall and ceiling finishes, facings, fascia, soffit, siding electrical equipment mounting boards, and other work as required.
- .6 Install rough bucks, nailers and linings to rough openings as required to provide backing for frames and other work.
- .7 Install wood cants, fascia backing, nailers, curbs and other wood supports as required and secure using galvanized fasteners.
- .8 Install sleepers as indicated.
- .9 Frame, anchor, fasten, tie and brace members to provide necessary strength and rigidity.
- .10 Countersink bolts where necessary to provide clearance for other work.
- .11 Use nailing disks for soft sheathing as recommended by sheathing manufacturer.

3.4 CLEANING

- .1 Progress Cleaning:

- .1 Leave Work area clean at end of each day.
- .2 Final Cleaning: upon completion remove surplus materials, rubbish, tools and equipment.

3.5 PROTECTION

- .1 Protect installed products and components from damage during construction.
- .2 Repair damage to adjacent materials caused by rough carpentry installation.

END OF SECTION

1 General

1.1 This specification section applies to the SBS roof replacement of the main roof and two penthouses of Building #22 located at 960 Carling Avenue Ottawa.

1.2 Scope of Work

- .1 Test cuts to confirm the existing assemblies are the contractor's responsibility.
- .2 Disconnect mechanical systems before the re-roofing commences and reinstate upon completion of the work for each section. Follow the phased construction schedule given on the roof plan not to disrupt building operations.
- .3 Remove and discard from site existing roof system (metal flashings, insulation and membranes) down to the existing vapour barrier. Note: the existing ballast can be disposed of on site for future use by the Client.
- .4 Inspect vapour barrier for visible signs of mould and advise Consultant immediately if mould suspected.
- .5 Remove and discard from site any loose or deteriorated vapour barrier.
- .6 Inspect concrete deck for any signs of significant cracking, spalling, exposed reinforcement, or surface deterioration. Repair deck as directed by Consultant.
- .7 Install new plywood and blocking to up stands, parapets, and wall junction substrates as per detail and approved shop drawings. Ensure minimum membrane flashing height of 200 mm.
- .8 Prime and install new self-adhesive vapour barrier continuity strips as vapour barrier wrap / flame stop membrane at all up stands, parapets, and wall junctions. Ensure 75 mm extension above insulation overlay board finish height.
- .9 Prime and install new torch applied modified bitumen vapour barrier.
- .10 Replace existing drains with new retrofit drains.
- .11 Review surface drainage on vapour barrier with consultant before proceeding with insulation installation.
- .12 Adhere 3.5" [R20] Polyisocyanurate insulation with pre-manufactured 8' x 8' sumps around drains.
- .13 Adhere Tapered Polyisocyanurate insulation with 1% slope.
- .14 Adhere bituminous insulation overlay.
- .15 Install torch applied base sheet.
- .16 Prime and install self-adhesive base sheet flashings and heat welded gussets.
- .17 Install torch applied cap sheet and cap sheet flashings
- .18 Complete the miscellaneous waterproofing details.

1.3 REFERENCE STANDARD(S)

- .1 Wind Uplift resistance
 - .1 Submit a report, issued by a certified materials testing laboratory, attesting that the specified roofing system was tested in accordance with CSA A123.21-10, *Standard test method for the dynamic wind uplift resistance of membrane-*

roofing systems. Test results shall demonstrate that the roofing system provides a Dynamic Uplift Resistance (DUR) of 75 psf or;

- .2 Submit a report showing that the specified roofing system has been tested for Wind Uplift Resistance in accordance with FM 4470 Standard. The test results shall demonstrate that the roofing system provides a resistance of 90 psf for the field surface of the roof. Edges and corners must be installed according to the requirements listed in FM PLPDS 1-29.]

- .2 Membranes must meet or exceed requirements of CGSB 37.56–M (9th Draft), *Membrane, Modified, Bituminous, Prefabricated, and Reinforced for Roofing*.]
- .3 Membranes must meet or exceed requirements of ASTM D 6162, Standard Specification for Styrene Butadiene Styrene (SBS) Modified Bituminous Sheet Materials Using a Combination of Polyester and Glass Fibre Reinforcements.]
- .4 Membranes must meet or exceed requirements of ASTM D 6163, Standard Specification for Styrene Butadiene Styrene (SBS) Modified Bituminous Sheet Materials Using Glass Fibre Reinforcements.
- .5 Polyisocyanurate thermal insulation boards must meet or exceed requirements of CAN/ULC S704-011, *Thermal Insulation, Polyurethane and Polyisocyanurate, Boards Faced*].
- .6 Roofing system must meet or exceed requirements of CAN/ULC-S107-10, *Methods of Fire Tests of Roof Coverings, Class C*.

1.4 COMPATIBILITY

- .1 All waterproofing materials will be single sourced from the same manufacturer, or approved for use in their total system warranty, and included in their wind uplift and fire resistance approvals.

1.5 TECHNICAL DATA

- .1 Submit two (2) copies of the most current technical data sheets. These documents must describe the materials' physical properties.

1.6 CONTRACTOR QUALIFICATION

- .1 Roofing contractors and sub-contractors must, when tendering or performing work, possess a roofing contractor operating license.
- .2 Roofing contractors must also be registered with manufacturer's certification program and provide the Consultant with a manufacturer certificate to this effect before beginning any roofing work.
- .3 Only qualified, certified installers employed by a company with the appropriate equipment may execute the roofing work.
- .4 The contractor must submit 3 projects successfully completed within the last 3 years for which the work was, minimum, of same quantity and quality as those included in the presents. Every submitted project must be accompanied with a reference including its name and phone number.

1.7 MANUFACTURER'S REPRESENTATIVE

- .1 The roofing product manufacturer must delegate a representative to visit the work site at the start of roofing installation, upon completion, and at all other times as

required to enable them to warrant the completed work. It is incumbent upon the Roof Contractor to ensure this takes place.

- .2 The contractor must at all times enable and facilitate access to the work site by said representative.

1.8 INSPECTION

- .1 Roof installation inspections will be performed by the Consultant.
- .2 All inspection fees will be paid by the owner, unless deficient workmanship results in additional and unforeseen inspection requirements. Additional inspections due to poor workmanship or planning may be invoiced to the contractor

1.9 PRE-INSTALLATION MEETING

- .1 Attend an on-site pre-roof meeting [prior to commencement] with the roofing contractor's representative, roofing foreman, and the Consultant present. The purpose of this meeting is to review site conditions, scope of work, installation procedures and others particular to the project.

1.10 STORAGE AND DELIVERY

- .1 All materials will be delivered and stored in conformance with the requirements described in the MANUFACTURER'S MANUAL; they must remain in their original packaging, displaying the manufacturer's name, product name, weight, and reference standards, as well as all other indications or references considered standard.
- .2 At all times, materials will be adequately protected and stored in a dry, elevated and properly ventilated area, away from any welding flame or spark and sheltered from the elements or any harmful substance. Only materials destined for same-day use can be removed from this storage area. In cold weather, these materials should be stored in a heated area at a minimum temperature of +10⁰C and removed prior to application. If rolls cannot be stored in a heated environment, they may be pre-conditioned before installation. For precise description, please consult MANUFACTURER'S "Roofers' Guide" on membrane application procedures.
- .3 Store adhesives and emulsion-based waterproofing mastics at a minimum +5⁰C. Store adhesives and solvent-based mastics at sufficient temperatures to ensure ease of application.
- .4 Materials delivered in rolls will be carefully stored upright; metal flashings will be secured and stored to avoid creasing, buckling, scratches or any other possible damage.
- .5 Avoid material overloads [PPL] which may affect the structural integrity of specific roof areas.

1.11 FIRE PROTECTION

- .1 Prior to the start of work, conduct a site inspection to establish safe working practices and make sure that all procedures and proposed changes are approved to minimize the risk of fires.
- .2 Respect safety measures described in the MANUFACTURER's Specifications Manual as well as CRCA recommendations.
- .3 At the end of each workday, use a heat detector gun to spot any smouldering or concealed fire. Job planning must be organized to ensure workers are on location at

least one hour after torch application completion to perform the “fire watch inspection”.

- .4 Never apply the torch directly to any combustibles.
- .5 Throughout roofing installation, maintain a clean site and have one approved ABC fire extinguisher within 6 metres of each operable roof torch. Respect all safety measures described in technical data sheets. Torches must never be placed near combustible or flammable products. Torches should never be used where the flame is not visible or cannot be easily controlled. Heating of propane bottles is strictly prohibited.

1.12 WARRANTIES

- .1 The membrane manufacturer will issue a written document in the owner’s name, valid for a 10 year period, saying that it will repair any leaks in the roofing membrane to restore the roofing system to a dry and watertight condition, to the extent that defects in roofing material or installation methods caused water infiltration. The warranty must cover for the entire cost of the repair(s), excluding removal of overburden, during the entire warranty period. The warranty must be transferable, at no extra cost, to subsequent building owners.
- .2 The contractor will provide a written and signed document to the owner certifying that the work executed will remain in place and free of waterproofing defect for a period of 2 years from the date of acceptance.

2 Products

2.1 DESIGN REQUIREMENTS

- .1 The roof engineering design has been completed using an assembly of materials as required to produce a complete roofing system with the necessary wind uplift resistance, fire resistance, total system warranty, and other requirements of the specifications and provincial building code. All proposed systems must meet the individual product specifications below, as well as required system performance:

2.2 MODIFIED BITUMEN VAPOUR BARRIER

- .1 Description: Roofing membrane composed of SBS modified bitumen and a glass mat reinforcement. The upper surface is sanded, the underface is covered with a thermofusible plastic film.
- .2 In conformance with: CAN/CGSB 37.56-M (9th Draft).

.1 Properties:	MD	XD
.1 Strain energy (kN/m)	1.3	1.3
.2 Breaking strength (kN/m)	11	8.5
.3 Ultimate elongation (%)	4	4
.4 Tear resistance (N)	30	
.5 Static puncture resistance (N)	160	
.6 Dimensional stability (%)	0	0
.7 Plastic flow (°C)	≥ 110	
.8 Cold bending at -30 °C	No cracking	
.9 Thickness (mm)	2.2m	
.10 Roll Dimension	15m x 1m	

2.3 VAPOUR RETARDER CONTINUITY STRIP:

- .1 Description: Self-adhesive flame stop membrane composed of glass fleece reinforcement and SBS modified bitumen.

2.4 INSULATION

- .1 Description: Closed-cell, Polyisocyanurate foam core integrally laminated to heavy, black (non-asphaltic), fibre-reinforced organic felt facers.
- .2 LTTR (long-term thermal resistance) values determined in accordance with CAN/ULC-S770 and ASTM C 1289.
- .3 Recycled Content: Between 16% and 43% by weight, depending on thickness (57% post-consumer, 43% pre-consumer).
- .4 1.2 m. x 1.2 m (4' x 4'). Thickness 84 mm (3.5"), R20.
- .5 Pre-fabricated drain sumps, 2.4m x 2.4m (8' x 8'), reducing thickness of insulation by a minimum of 25 mm (1") at all drains.

2.5 TAPERED INSULATION

- .1 Description: Closed-cell, Polyisocyanurate foam core integrally laminated to heavy, black (non-asphaltic), fibre-reinforced organic felt facers.

2.6 INSULATION OVERLAY

- .1 Bituminous panels:
 - .1 Description: Multi-ply, semi-rigid asphaltic roofing substrate board composed of a mineral fortified asphaltic core formed between two asphaltic saturated fibreglass liners. 1.2 m x 1.5 m. Thickness 3.2 mm.

2.7 ROOF MEMBRANES

- .1 Base Sheet Membrane for Field Surface
 - .1 Description: Roofing membrane composed of SBS modified bitumen and a composite reinforcement. The surface is covered with a thermofusible plastic film, the underside is sanded. The surface must be marked with three (3) chalk lines to ensure proper roll alignment.
 - .2 Meets or exceeds properties of ASTM D6162
 - .3 In conformance with: CGSB 37.56-M (9th Draft).
 - .4 Properties:

	MD	XD
.1 Strain energy (kN/m)	7.8	7.2
.2 Breaking strength (kN/m)	15	13.5
.3 Ultimate elongation (%)	60	65
.4 Tear resistance (N)	125	
.5 Static puncture resistance (N)	560	
.6 Dimensional stability (%)	0.2	0
.7 Plastic flow (°C)	≥ 110	
.8 Cold bending at -30 °C	No cracking	
.9 Lap joint strength (kN/m)	Pass > 4 kN/m	

.2 Base Sheet Membrane for Flashings and Parapets

- .1 Description: Membrane composed of SBS modified bitumen and glass reinforcement. The surface is covered with a thermofusible plastic film and the underface is covered with a release protection film. The surface shall be marked with three (3) chalk lines to ensure proper roll alignment.

.3 Roofing Cap Sheet Membrane for Field And Parapet Surfaces

- .1 Description: Roofing membrane composed of SBS modified bitumen with a composite reinforcement and elastomeric bitumen. The surface is protected by coloured granules. The underface is covered with a thermofusible plastic film.

- .2 Meets or exceeds properties of ASTM D6162

- .3 In conformance with: CGSB 37.56-M (9th Draft).

.4 Properties:	MD	XD
.1 Strain energy (kN/m)	7.8	7.2
.2 Breaking strength (kN/m)	15	13.5
.3 Ultimate elongation (%)	60	65
.4 Tear resistance (N)	125	
.5 Static puncture resistance (N)	560	
.6 Dimensional stability (%)	0.2	0
.7 Plastic flow (°C)	≥ 110	
.8 Cold bending at -30 °C	No cracking	
.9 Lap joint strength (kN/m)	Pass > 4 kN/m	

2.8 ACCESSORY MEMBRANES

.1 Reinforcement membrane:

- .1 Description: Roofing membrane with composite heavy duty reinforced and SBS modified bitumen. Both sides are covered with a thermofusible plastic film. The top face must be marked with three (3) distinctive blue chalk lines to ensure proper roll alignment.

- .2 Prefabricated membrane, complies with CAN/CGSB 37-GP-56M (9th draft)

2.9 PRIMER

.1 Primer for heat welded membranes:

- .1 Description: A blend of elastomeric bitumen, volatile solvents and adhesive enhancing additives used to prime concrete or metal substrates to enhance the adhesion of torch-applied waterproofing membranes.

.2 Primer for self-adhesive membranes:

- .1 Description: Polymeric emulsion finish designed to improve adherence of self-adhesive waterproofing membranes when solvent-based primer is not recommended.

2.10 ADHESIVES

- .1 Insulation and insulation overlay board adhesive: Low-Rise two-part urethane adhesive without minimum application temperature, available in dual cartridge with mixing nozzle to ensure proper mixing.

2.11 PLUMBING STACKS

- .1 Plumbing stacks to be one piece, spun aluminium vents with cap to match.

2.12 ROOF DRAINS (RETROFIT DRAINS)

- .1 Description: Aluminium retrofit drain insert using compressible connectors, complete with cast aluminium domes and copper flange.
- .2 Outlet pipe and connector size to match existing drain line diameter.

2.13 ROOF DRAINS (NEW DRAINS)

- .1 Description: Aluminium drains with aluminium dome and copper sleeve. Outlet pipe diameter to match existing drain size on site

2.14 COMPLEMENTARY WATERPROOFING PRODUCTS

- .1 Waterproofing mastic:
 - .1 Description: Mastic made of synthetic rubbers, plasticized with bitumen and solvents with Aluminum pigments to provide resistance to UV.
- .2 Sealing product
 - .1 Description: One component bitumen/polyurethane waterproofing with polyester reinforcements. Designed to finish upstands and details.

3 EXECUTION

3.1 SURFACE EXAMINATION AND PREPARATION

- .1 Surface examination and preparation must be completed in conformance with 'recommendations in the MANUFACTURER Specifications Manual, particularly for fire safety precautions.
- .2 Before roofing work begins, the BTC and Contractors representatives will inspect and approve deck conditions (including slopes and wood blocking) as well as upstands, parapets, construction joints, roof drains, plumbing vents, ventilation outlets and others. The start of roofing work will certify that roofing conditions are acceptable for work to commence.
- .3 Do not begin any work before surfaces are smooth, dry, well secured and free of debris. Use of calcium or salt is forbidden for ice or snow removal.
- .4 Make sure plumbing, carpentry, mechanical, electrical and all other project related items have been duly completed as required.
- .5 No materials to be installed during rain, snowfall and or inclement weather.

3.2 SET-UP

- .1 Advise consultant of set-up schedule with dates, times and expected durations for all activities.
- .2 Install equipment and materials at approved locations

3.3 SITE PROTECTION

- .1 Contractor to review all staging areas for underground and above ground structures, such as underground parking, gas mains, loading docks, fire hydrants and routes, hydro and natural gas lines etc. Contractor will advise BTC of any concerns before commencement of the project.

- .2 All buildings, structures etc. to be adequately protected as required with the use of planking, sheathing, tarpaulins, scaffolding.
- .3 Public access will be strictly restricted from all immediate work areas with the use of signage and fencing.
- .4 Protect finished work to avoid damage during roof installation and material transportation. Install protective boardwalks over installed roofing materials to enable passage of personnel, equipment and materials. Contractor will assume full responsibility for any damage.
- .5 All materials, tools and equipment must be secured in place at the closing of each work day to prevent from movement due to inclement weather.
- .6 All ground staging areas to be secured and locked nightly to prevent vandalism and theft.

3.4 CLEANING

- .1 The entire work site must be routinely [minimum daily] organized and or cleared of rubbish, materials, tools and equipment which may hinder roof installation, performance, fire hazards and to eliminate dangerous conditions to the occupants and public.

3.5 EQUIPMENT FOR WORK EXECUTION

- .1 Maintain all equipment and tools used during the project in a respectable working order.

3.6 REMOVALS

- .1 Remove all existing roofing membrane and metal flashings down to structural deck.
- .2 Prepare existing substrates to receive new roofing system.

3.7 METHOD OF INSTALLATION

- .1 Install roofing materials on clean, dry and properly secured surfaces in conformance with manufacturer's instructions and recommendations.
- .2 Roofing work must be completed in a continuous fashion as surfaces are readied and weather conditions permit.
- .3 Whenever membranes are torch-applied, a continuous and even bead of molten bitumen must be visible as the membrane is unrolled and welded.
- .4 Maintain the field of work in a water tight fashion on a daily basis.
- .5 Complete all work (temporary supports for equipment and bases, disconnection and connection of equipment as needed, moving and lifting of bases, etc.) required for waterproofing beneath equipment and bases as shown on drawings; use qualified trade persons as required. Temporary supports for waterproofing beneath air-conditioning units must be designed to hold supported loads and distribute these loads to avoid structural damage. Avoid interruption of functioning equipment during roofing. Unavoidable interruptions must be planned with the Consultant may require scheduling outside normal working hours.

3.8 APPLICATION OF THERMOFUSIBLE VAPOUR BARRIER

- .1 Primer must be dry prior to the installation of the vapour barrier membrane.

- .2 Starting at the lowest point of the roof slope, the vapour barrier membrane must be heat-welded onto the substrate in conformance with manufacturer's written recommendations.
- .3 Overlap adjacent rolls of 75 mm (3 in) and 100 mm (4 in). End laps must be 150 mm (6 in). Space end laps by at least 300 mm (12 in).
- .4 The roof vapour barrier must meet and overlap the air/vapour barrier on adjoining walls to ensure total continuity.
- .5 Pull up vapour barrier at insulation perimeters and around each element penetrating it to ensure sealed connections with flashing base sheet.

3.9 INSULATION (BASE AND TAPERED) INSTALLATION

- .1 Field and Edge: Apply insulation to vapour retarder with specified adhesive applied in 20 mm wide strips every 300 mm using the manufacturer's approved applicator.
- .2 Corner: Apply insulation to vapour retarder with specified adhesive applied in 20 mm wide strips every 150 mm using the manufacturer's approved applicator.
- .3 Install boards in a staggered formation, butting all edges closely and score cut to eliminate all cupping and warping.
- .4 Score cut boards as required at all undulations in the substrate to allow for full contact and walk in place to ensure full adhesion. Particular attention required at all slopes in the concrete slab.
- .5 Cut insulation boards to fit snugly at all perimeters, roof opening etc. but not oversized to damage the vapour barrier during installation.
- .6 All vertical joints between each course of insulation will be staggered.
- .7 Install only as much insulation as can be covered and completed in a water tight fashion by days end.
- .8 All gaps in the insulation around roof penetrations etc are to be packed with batt insulation.

3.10 INSTALLATION OF INSULATION OVERLAY

- .1 Field and Edge: Apply boards with the specified adhesive; applied in 20 mm. wide bands every 300 mm. using the manufacturer's approved applicator. Apply at a rate of 2 kg to 3 kg. per square metre.
- .2 Corner: Apply boards with the specified adhesive; applied in 20 mm. wide bands every 150 mm. using the manufacturer's approved applicator. Apply at a rate of 4 kg to 6 kg. per square metre.
- .3 All vertical joints between boards and insulation will be staggered.
- .4 All the panels will be installed in a tight fitting, level manner with adherence as per the manufactures instructions.
- .5 Apply only as many boards as can be covered and made in a water tight condition by the days end.

3.11 INSTALLATION OF TORCH APPLIED BASE SHEET

- .1 Loose lay the base sheet membrane on the substrate, taking care to align the starting edge of the roll with the drain.

- .2 After alignment back roll the membrane and commence the torch application while obtaining a continuous bead of bitumen at the side laps as the membrane is unrolled and assuring the complete adherence throughout.
- .3 Each strip should overlap the preceding strip by 75 mm. along the side joint (use the blue line to facilitate alignment) and by 150 mm. at the ends. Stagger the end joints by at least 300 mm.
- .4 At end laps, angle-cut the corners that will be covered by the following roll.
- .5 Special care must be taken to avoid creating wrinkles, blisters, and fish mouths in the base sheet membrane.

3.12 BASE SHEET FLASHING INSTALLATION (SELF ADHERED)

- .1 Apply base sheet flashing only after primer coat is dry.
- .2 Before applying membranes, always burn the plastic film from the section to be covered if there is an overlap (inside and outside corners and field surface). For sanded base sheet membranes, apply primer for self-adhesive membrane on the area to be covered at the foot of the parapets.
- .3 Cut off corners at end laps of areas to be covered by the next roll.
- .4 Each selvedge will overlap the previous one along lines provided for this purpose, and by 150 mm (6 in) at the ends.
- .5 Position the pre-cut membrane. Remove 150 mm (6 in) of the silicone release film to hold the membrane in place at the top of the parapet.
- .6 Then, gradually peel off the remaining silicone release film, pressing down on the membrane with an aluminum applicator to ensure good adhesion. Use the aluminum applicator to ensure a perfect transition between the flashing and the field surface. Smooth the entire membrane surface with a membrane roller for full adhesion.
- .7 Install a reinforcing gusset at all inside and outside corners.
- .8 Always seal overlaps at the end of the workday.
- .9 Avoid wrinkling, swelling or fish mouths.

3.13 INSTALLATION OF REINFORCED GUSSETS

- .1 Install reinforcements specified for various roof surfaces according to the following instructions and illustrations found in the manufactures technical data.

3.14 INSTALLATION OF THERMOFUSIBLE CAP SHEET ON FIELD SURFACE

- .1 Once base sheet is applied and no defects are apparent, proceed with cap sheet installation.
- .2 Begin with double-selvedge starter roll. If starter roll is not used, side laps covered in granules must be DE granulated by embedding side laps in torch-heated bitumen over a 75 mm. width.
- .3 Unroll cap sheet at drain. Carefully align first side lap (parallel to roof edge).
- .4 Weld cap sheet onto base sheet with torch recommended by membrane manufacturer. During application, simultaneously melt both designated contact surfaces so a bead of bitumen is apparent as cap sheet unrolls.
- .5 Avoid overheating.

- .6 Make sure joints between the two layers are staggered by at least 300 mm.
- .7 Overlap cap sheet side laps by 75 mm. and end laps by 150 mm. Cut off corners at end laps to be covered by next roll. All overlap surfaces must be degranulated.
- .8 Complete perfect welds between two membranes. Leave no zone unwelded. In cold weather, adjust welding time to obtain homogenous seam (it may be necessary to slow down in certain cases.)
- .9 Once cap sheet is installed, carefully check all overlapped joints.
- .10 During installation, take care to avoid excessive bitumen bleed-out at joints.

3.15 INSTALLATION OF THERMOFUSIBLE CAP SHEET ON FLASHINGS AND PARAPETS

- .1 This cap sheet must be installed in one-metre-wide strips (3.25 ft).
- .2 Each selvedge will overlap the previous one laterally along lines provided for this purpose, and will overlap by 150 mm (6 in) the field surface. Membranes for flashings must be spaced at least 100 mm (4 in) with respect to the cap sheet membranes on the field surface, to avoid areas of excessive membrane thickness.
- .3 Cut off corners at end laps on areas to be covered by the next roll.
- .4 Use a chalk line to draw a straight line on the field surface, 150 mm (6 in) from flashings and parapets.
- .5 Use a torch and round-nose trowel to embed the surface granules in the layer of hot bitumen, starting from the chalk line on the field surface to the bottom edge of the flashing or parapet, as well as on the granulated vertical surfaces to be overlapped.
- .6 This cap sheet will be heat-welded directly to the base sheet membrane, proceeding from bottom to top.
- .7 Avoid the formation of wrinkles, swellings or fishmouths.
- .8 During installation, be careful not to overheat the membrane and its reinforcements.

3.16 ROOFING FOR VARIOUS DETAILS

- .1 All existing rain water leaders to be thoroughly prepared within to allow for a complete and uninterrupted seal with the new u-flow connector.
- .2 Install waterproofing membranes in conformance with various roofing details illustrated in the Manufactures manual.
- .3 Ensure all mechanical and electrical penetrations are completed using prefabricated roof accessories, or insulated boxes as required. Pitch Pockets will not be accepted.

- END OF SECTION -

Part 1 General

1.1 REFERENCES

- .1 The Aluminum Association Inc. (AAI)
 - .1 AAI-Aluminum Sheet Metal Work in Building Construction-2002.
 - .2 AAI DAF45-03, Designation System for Aluminum Finishes.
- .2 American Society for Testing and Materials International (ASTM)
 - .1 ASTM A167-99(2004), Specification for Stainless and Heat-Resisting Chromium-Nickel Steel Plate, Sheet, and Strip.
 - .2 ASTM A240/A240M-07e1, Standard Specification for Chromium and Chromium-Nickel Stainless Steel Plate, Sheet, and Strip for Pressure Vessels and for General Applications.
 - .3 ASTM A606-04, Standard Specification for Steel, Sheet and Strip, High-Strength, Low-Alloy, Hot-Rolled and Cold-Rolled, with Improved Atmospheric Corrosion Resistance.
 - .4 ASTM A653/A653M-07, Standard Specification for Steel Sheet, Zinc-Coated (Galvanized) or Zinc-Iron Alloy-Coated (Galvannealed) by the Hot-Dip Process.
 - .5 ASTM A792/A792M-06a, Standard Specification for Steel Sheet, 55% Aluminum-Zinc Alloy-Coated by the Hot-Dip Process.
 - .6 ASTM B32-04, Standard Specification for Solder Metal.
 - .7 ASTM B370-03, Standard Specification for Copper Sheet and Strip for Building Construction.
 - .8 ASTM D523-89(1999), Standard Test Method for Specular Gloss.
 - .9 ASTM D822-01(2006), Standard Practice for Filtered Open-Flame Carbon-Arc Exposures of Paint and Related Coatings.
- .3 Canadian Roofing Contractors Association (CRCA)
 - .1 Roofing Specifications Manual 1997.
- .4 Canadian General Standards Board (CGSB)
 - .1 CAN/CGSB-51.32-M77, Sheathing, Membrane, Breather Type.
 - .2 CAN/CGSB-93.1-M85, Sheet Aluminum Alloy, Prefinished, Residential.
- .5 Canadian Standards Association (CSA International)
 - .1 CSA A123.3-05, Asphalt Saturated Organic Roofing Felt.
 - .2 AAMA/WDMA/CSA 101/I.S.2/A440-2008, Standard/Specification for Windows, Doors, and Unit Skylights.
 - .3 CSA B111-1974(R2003), Wire Nails, Spikes and Staples.
- .6 Green Seal Environmental Standards
 - .1 Standard GS-03-93, Anti-Corrosive Paints.
 - .2 Standard GS-11-97, Architectural Paints.
 - .3 Standard GS-36-00, Commercial Adhesives.
- .7 Health Canada/Workplace Hazardous Materials Information System (WHMIS)
 - .1 Material Safety Data Sheets (MSDS).
- .8 Provide submittals in accordance with Section 01 33 00 - Submittal Procedures.
- .9 Product Data:
 - .1 Submit manufacturer's printed product literature for sheet metal flashing systems materials, specifications and datasheet and include product characteristics, performance criteria, physical size, finish and limitations.

- .2 Submit two copies WHMIS MSDS - Material Safety Data Sheets
- .10 Shop Drawings:
 - .1 Shop drawings: submit drawings requested by consultant.
- .11 Samples:
 - .1 Submit duplicate 50 x 50 mm samples of each type of sheet metal material, finishes and colours.
- .12 Quality assurance submittals: submit following in accordance with Section 01 33 00.
 - .1 Manufacturer's Instructions: submit manufacturer's installation instructions and special handling criteria, installation sequence, cleaning procedures.

1.2 QUALITY ASSURANCE

- .1 Pre-Installation Meetings: convene pre-installation meeting one week prior to beginning work of this Section and on-site installation, with contractor's representative and Departmental Representative, and Engineer to:
 - .1 Verify project requirements.
 - .2 Review installation and substrate conditions.
 - .3 Co-ordination with other building sub trades.
 - .4 Review manufacturer's installation instructions and warranty requirements.

1.3 DELIVERY, STORAGE AND HANDLING

- .1 Deliver, store and handle materials in accordance with manufacturers' instructions.
- .2 Waste Management and Disposal:
 - .1 Separate waste materials for recycling.

2 Part 2 Products

2.1 PREFINISHED STEEL SHEET

- .1 Prefinished steel with factory applied silicone modified polyester, Class F1S, Series 8000.
- .2 Colour selected by Owner / The BTC Representative from manufacturer's standard range.
- .3 Specular gloss: 30 units +/- 5 in accordance with ASTM D523.
- .4 Coating thickness: to be not less than 25 micrometres.
- .5 Resistance to accelerated weathering for chalk rating of 8, colour fade 5 units or less and erosion rate than 20% to ASTM D822 as follows:
 - .1 Outdoor exposure period 1000 hours.
 - .2 Humidity resistance exposure period 1000 hours.
 - .3 Base metal thickness 0.58 mm (26 gauge) unless indicated otherwise. Base metal to be hot-dipped galvanized steel with coating designation Z7275 (G90).

2.2 ACCESSORIES

- .1 Sealing Compound: one component polyurethane base caulking compound to CGSB 19.13-M87. Standard of Acceptance shall be Tremco Dymonic, Sikaflex 1a by Sika, or Sternson RC-1. Sealing compound to be installed in accordance with manufacture's recommendations.
- .2 Cleats and Continuous Starters: of same material and temper as sheet metal, minimum 50.8 mm (2") wide. Thickness of continuous starter to be 24 gauge.

- .3 Fasteners: of same material as sheet metal, to CSA B111, ring thread flat head roofing nails of length and thickness suitable for metal flashing application.
- .4 Exposed fasteners: Prefinished steel screws, hexagonal head with colour to match metal flashing colour, with neoprene washers.
- .5 Touch-up paint: as recommended by metal flashing and trim manufacturer.
- .1 VOC content will be not more than 50 to 150 g/L per GS-11 SCAQMD Rule 1113.

2.3 FABRICATION

- .1 Fabricate metal flashings and other sheet metal work in accordance with applicable CRCA 'FL' series specifications as indicated.
- .2 For pieces in 2400 mm (96") maximum lengths.
- .3 Make allowances for expansion at joints.
- .4 Hem exposed edges on underside 12 mm (1/2").
- .5 Mitre and seal corners with sealant.
- .6 Form sections square, true and accurate to size, free from distortion and other defects detrimental to appearance or performance.

2.4 METAL FLASHINGS

- .1 Form flashings, copings and drip edges to profiles indicated on drawings, from 0.58 mm thick (26 ga,) prefinished steel.
- .2 Provide slip-lock type joints for vertical faces and coping. Provide 76.2 mm (3") lap joints at horizontal drip edges.

3 Execution

3.1 INSTALLATION

- .1 Install sheet metal and metal siding in accordance with CRCA FL series, SMACNA and manufacturer's specifications, and as detailed.
- .2 Use concealed fastenings except where approved before installation.
- .3 Provide underlay under sheet metal.
 - .1 Secure in place and lap joints 100 mm.
- .4 Counterflash bituminous flashings at intersections of roof with vertical surfaces and curbs.
 - .1 Flash joints using standing seams forming tight fit over hook strips.
- .5 Lock end joints and caulk with sealant.
- .6 Install surface mounted reglets true and level, and caulk top of reglet with sealant.

End of Section 07 62 00

1.1 GENERAL

1.2 SCOPE OF WORK

- .1 This Section contains requirements for the installation of sealants and related caulking materials components and accessories.
- .2 Work of this section includes cleaning and/or cutting of reglet joints where shown on the Drawings.

1.3 REFERENCES

- .1 Canadian General Standards Board (CGSB)
 - .1 CGSB 19-GP-14M-[1984], Sealing Compound, One Component, Butyl-Polyisobutylene Polymer Base, Solvent Curing (Reaffirmation of April 1976).
 - .2 Health Canada/Workplace Hazardous Materials Information System (WHMIS)
 - .1 Material Safety Data Sheets (MSDS).

1.4 SUBMITTALS

- .1 Submit product data in accordance with Section 01 33 00 - Submittal Procedures.
- .2 Manufacturer's product to describe.
 - .1 Caulking compound.
- .3 Cured samples of exposed sealants for each color where required to match adjacent material.
- .4 Submit manufacturer's instructions in accordance with Section 01 33 00 - Submittal Procedures.
 - .1 Instructions to include installation instructions for each prod

1.5 QUALITY ASSURANCE/MOCK-UP

- .1 Construct mock-up to show location, size, shape and depth of joint [s] complete with back-up material, primer, caulking and sealant.
- .2 Mock-up will be used:
 - .1 To judge workmanship, substrate preparation, operation of equipment and material application.
- .3 Locate where directed.
- .4 Allow 24 hours for inspection of mock-up by Consultant before proceeding with sealant work.
- .5 When accepted, mock-up will demonstrate minimum standard of quality required for this Work. Approved mock-up may remain as part of finished Work. Remove mock-up and dispose of materials when no longer required and when directed by Consultant.

1.6 DELIVERY, STORAGE, AND HANDLING

- .1 Deliver, handle, store and protect materials in accordance with manufacturer's recommendations.
- .2 Deliver and store materials in original wrappings and containers with manufacturer's seals and labels, intact. Protect from freezing, moisture, water and contact with snow or ice; do not store directly on ground or rooftop

1.7 WASTE MANAGEMENT AND DISPOSAL

- .1 Remove from site and dispose of packaging materials at appropriate recycling facilities.
- .2 Place materials defined as hazardous or toxic in designated containers.
- .3 Handle and dispose of hazardous materials in accordance with the CEPA, TDGA, Regional and Municipal regulations.
- .4 Unused material must not be disposed of into sewer system, into streams, lakes, onto ground or in other location where it will pose health or environmental hazard.
- .5 Divert unused joint sealing material from landfill to official hazardous material collections site approved by Consultant.
- .6 Empty plastic joint sealer containers are not recyclable. Do not dispose of empty containers with plastic materials destined for recycling.
- .7 Fold up metal banding, flatten, and place in designated area for recycling.

1.8 PROJECT CONDITIONS

- .1 Environmental Limitations:
 - .1 Do not proceed with installation of joint sealants under following conditions:
 - .1 When ambient and substrate temperature conditions are outside limits permitted by joint sealant manufacturer or are below 4.4 degrees C.
 - .2 When joint substrates are wet.
 - .2 Joint-Width Conditions:
 - .1 Do not proceed with installation of joint sealants where joint widths are less than those allowed by joint sealant manufacturer for applications indicated.
 - .3 Joint-Substrate Conditions:
 - .1 Do not proceed with installation of joint sealants until contaminants capable of interfering with adhesion are removed from joint substrates.

1.9 ENVIRONMENTAL REQUIREMENTS

- .1 Comply with requirements of Workplace Hazardous Materials Information System (WHMIS) regarding use, handling, storage, and disposal of hazardous

materials; and regarding labelling and provision of Material Safety Data Sheets (MSDS) acceptable to Labour Canada.

- .2 Conform to manufacturer's recommended temperatures, relative humidity, and substrate moisture content for application and curing of sealants including special conditions governing use.
- .3 Ventilate area of work as directed by Engineer by use of approved portable supply and exhaust fans as required.

1.10 WARRANTY

- .1 Defective joint sealant installation covered under the warranty shall include but not be limited to: joint leakage, hardening, craze cracking, crumbling, melting, bubbling, shrinkage, runs, and sags, change of colour, loss of adhesion and staining of adjoining or adjacent material surfaces.
- .2 Provide replacement of defective work prior to the end of the warranty period according to the Consultant's recommendations at no additional cost to the Owner.
- .3 Inspect the sealant installation 60 days before expiry of warranty and correct defects within 15 days of inspection. This inspection shall be performed at no additional cost to the Owner.

Part 2 PRODUCTS

2.1 COMPATIBILITY

- .1 Compatibility between components of roofing system is essential. All roofing components which are to be incorporated into the system must be compatible with the designed roofing system.
- .2 At request of the Consultant, provide written declaration from the manufacturer that components/materials to be installed as part of roofing system are compatible and will not reduce the performance of the roofing system or void the Warranty.

2.2 MATERIALS

- .1 Elastomeric Sealants: One part elastomeric, non-sag urethane based sealant.
 - .1 Dymonic as manufactured by Tremco Ltd. or approved equal;
 - .2 Colour or colours of sealants shall be selected to match the substrate and shall be approved by the Consultant.
- .2 Primers of Surfaces to Receive Sealants: As recommended by the Manufacturer of the sealant.
- .3 Joint Backing:
 - .1 Polyethylene, urethane, neoprene or vinyl, extruded foam recommended by the sealant manufacturer.

Part 3 EXECUTION

3.1 PROTECTION

- .1 Protect installed Work of other trades from staining or contamination.

3.2 SURFACE PREPARATION

- .1 Examine joint sizes and conditions to establish correct depth to width relationship for installation of backup materials and sealants.
- .2 Clean bonding joint surfaces of harmful matter substances including dust, rust, oil grease, and other matter which may impair Work.
- .3 Do not apply sealants to joint surfaces treated with sealer, curing compound, water repellent, or other coatings unless tests have been performed to ensure compatibility of materials. Remove coatings as required.
- .4 Ensure joint surfaces are dry and frost free.
- .5 Prepare surfaces in accordance with manufacturer's directions.

3.3 PRIMING

- .1 Where necessary to prevent staining, mask adjacent surfaces prior to priming and caulking.
- .2 Prime sides of joints in accordance with sealant manufacturer's instructions immediately prior to caulking.

3.4 BACKUP MATERIAL

- .1 Apply bond breaker tape where required to manufacturer's instructions.
- .2 Install joint filler to achieve correct joint depth and shape, with approximately 30% compression.

3.5 MIXING

- .1 Mix materials in strict accordance with sealant manufacturer's instructions.

3.6 APPLICATION

- .1 Sealant.
 - .1 Apply sealant in accordance with manufacturer's written instructions.
 - .2 Mask edges of joint where irregular surface or sensitive joint border exists to provide neat joint.
 - .3 Apply sealant in continuous beads.
 - .4 Apply sealant using gun with proper size nozzle.
 - .5 Use sufficient pressure to fill voids and joints solid.
 - .6 Form surface of sealant with full bead, smooth, free from ridges, wrinkles, sags, air pockets, embedded impurities.
 - .7 Tool exposed surfaces before skinning begins to give slightly concave shape.
 - .8 Remove excess compound promptly as work progresses and upon completion.

- .2 Curing.
 - .1 Cure sealants in accordance with sealant manufacturer's instructions.
 - .2 Do not cover up sealants until proper curing has taken place.
- .3 Clean-up.
 - .1 Clean adjacent surfaces immediately and leave Work neat and clean.
 - .2 Remove excess and droppings, using recommended cleaners as work progresses.
 - .3 Remove masking tape after initial set of sealant.

End of Section 07 92 00

Part 1 – GENERAL

1.1 Scope of Work

- .1 Provide labour, Products, equipment and services for the mechanical work according to the Specifications.
- .2 Document and record location of all rooftop mechanical equipment, and label all rooftop equipment, brackets and supports.
- .3 Remove and store rooftop equipment in approved location for re-installation upon completion of each phase of roof replacement
- .4 Re-install rooftop mechanical equipment as per original configuration.
- .5 Perform commissioning operations with Owner to ensure all equipment is functional to Owner's satisfaction

1.2 Related Work

- .1 Co-ordinate work under this section with work of related sections listed below:
 - .1 Section 02 41 13 Selective Demolition and Removal
 - .2 Section 06 10 00 Rough Carpentry
 - .3 Section 07 62 00 Sheet Metal Flashing and Trim
 - .4 Section 07 92 00 Joint Sealing

1.3 Administrative Requirements

- .1 Read and conform to the requirements detailed in Division 1, which apply to, and form part of all sections of the work.
- .2 Carry out work to the highest standards of workmanship in the industry, by fully trained applicators according to written application instructions from the manufacturer.
- .3 Any damaged work that is not repaired, restored or cleaned to the Owner's satisfaction, shall be replaced at no cost to the Owner.
- .4 Inspect existing conditions, and substrates upon which work of this section is dependent. Report to the Consultant in writing any defects or discrepancies. Commencement of work implies acceptance of existing conditions and assuming full responsibility for the finished condition of the work.
- .5 Defective work resulting from application to unsatisfactory conditions will be considered the responsibility of those performing the work.

1.4 Action and Informational Submittals

- .1 Submit in accordance with Section 01 33 00 - Submittal Procedures.
- .2 Shop Drawings:

- .1 The contractor shall prepare and submit a roof plan and an itemized list identifying the location of all rooftop equipment and associated bracing for each mechanical unit on the rooftop.
- .2 The list shall be accompanied with a labelling strategy to ensure that all equipment, supports, brackets and braces will be adequately identified and stored to allow re-installation to meet or exceed current conditions
- .3 Submit an equipment localisation plan and labelling strategy, to be approved by the Consultant and the Owner prior to removing equipment form the rooftop.
- .4 Submit phasing plan identifying shutdown and start-up dates for each phase of re-roofing work.

1.5 Delivery, Storage and Handling

- .1 Storage and Protection.
 - .1 Protect existing items designated to remain and items designated for salvage. In event of damage to such items, immediately replace or make repairs to approval of Consultant and at no cost to Owner. These items include but are not limited to:
 - .1 Gas lines
 - .2 HVAC equipment
 - .3 Exhaust fans and other mechanical equipment on rooftop
 - .2 Remove and store materials to be salvaged, in manner to prevent damage.
 - .3 Store and protect in accordance with requirements for maximum preservation of material.
- .2 Handle salvaged materials as new materials.

Part 2 PRODUCTS

2.1 Materials

- .1 N/A

Part 3 EXECUTION

3.1 Mechanical Units and Mechanical/ Electrical Components

- .1 Shut off, disconnect, remove, store for reinstallation all related ductwork, piping and electrical components as required to permit roofing installation.
- .2 Disconnect all electrical conduits as required to permit installation of new sleeve flashings.

- .3 Reinstall mechanical units onto curbs or sleeper supports. Reconnect all ductwork, pipes and electrical conduits. Restart and check the operation of all equipment.
- .4 Perform this work promptly to minimize disruption of service. Service shall not be interrupted for longer than the scheduled phasing plan without approval from the Owner and Consultant.
- .5 All equipment, bracing or supports that are damaged during removal and re-installation, must be replaced with similar or superior bracing.

3.2 Cleaning

- .1 Remove all surplus materials and debris resulting from the foregoing work daily as the work proceeds and on completion.
- .2 Clean surfaces soiled by work of this section. Do not use chemicals, scrapers, or other tools in cleaning that will damage surfaces. Make good other work damaged under work of this section.

End of Section 23 05 01

KEY PLAN / PLAN CLÉ

- GENERAL NOTES / NOTES
1. THE GENERAL CONTRACTOR SHALL CHECK AND VERIFY ALL DIMENSIONS AND REPORT ALL ERRORS AND OMISSIONS TO THE CONSULTANT. / L'ENTREPRENEUR DOIT VÉRIFIER TOUTES LES MESURES ET DIMENSIONS ET AVISER LE CONSULTANT DE TOUTES ERREURS.
 2. ALL WORK AND MATERIALS TO BE IN COMPLIANCE WITH ALL CODES, REGULATIONS, AND BY-LAWS. / TOUT LES TRAVAUX ET MATÉRIAUX DOIVENT ÊTRE EN CONFORMITÉ AVEC TOUS LES CODES ET RÉGLEMENTS EN VIGUEUR.
 3. DO NOT SCALE DRAWINGS / NE PAS UTILISER LES DESSINS À L'ECHELLE POUR OBTENIR LES DIMENSION.
 4. ALL DIMENSIONS ARE TO FINISHED FACES / TOUTES DES DIMENSIONS SONT CALCULÉS À LA FACE EXTERIEUR DE L'ASSEMBLAGE.

NO.	REVISION	DATE
-----	----------	------

PROJECT NAME:	NOM DU PROJET
BUILDING 22 RE-ROOFING	EDIFICE 22 REFLECTION DE TOITURE

PROJECT NO:	PROJET NO:
-------------	------------

DRAWING TITLE:	DESSIN TITRE:
PLAN/PLAN	

DRAWN BY / DESSINÉE PAR:
SA

APPROVED BY / APPROUVÉE PAR:
MB

PROJECT MANAGER: ADMIN. DE PROJETS:
WLADYSLAW_WRZENIEWSKI

DATE:	DATE:
28/03/2014	28/03/2014

SCALE:	ECHELLE:
NTS	N/A

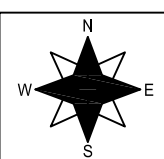
	DRAWING NO. NO. DU DESSIN 1
---	--

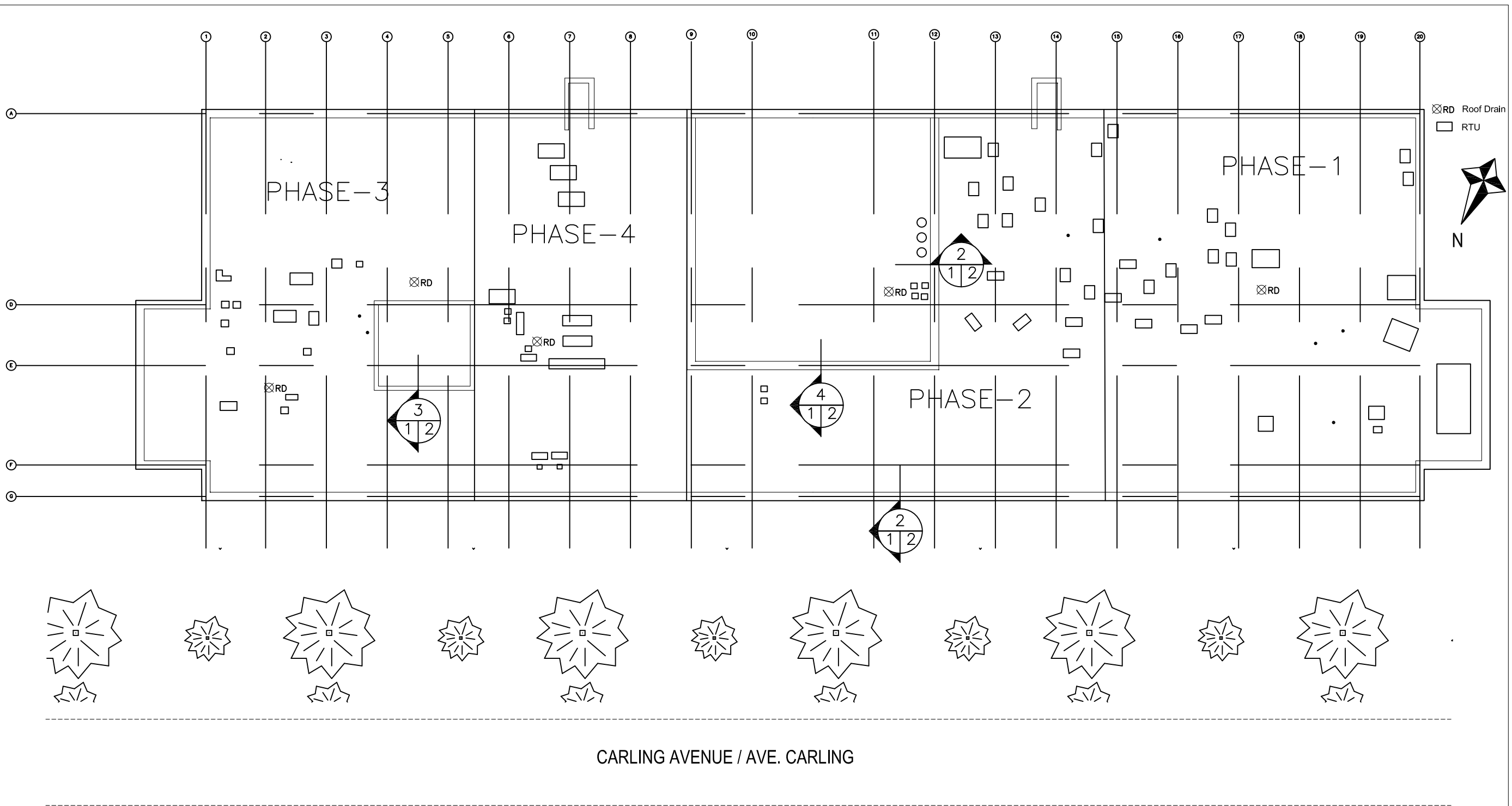

- Existing Roof System (Based on test cut) / Toiture Existente (Selon coupe d'essai)
Inverted Roof / Toiture Inversée:
- 4-ply built-up (BUR) membrane / Membrane 4 pli asphaltique.
 - Structural concrete deck / Pontage de béton.

- New Roof System / Nouveau Système de Toiture
- Torch applied base and cap sheet membrane / Membrane de finition thermofusible.
 - 3.2 mm (1/8") coverboard / Panneau asphaltique 3.2 mm (1/8").
 - 89 mm (3.5") PolyISO insulation / Isolant Polyisocyanurate 89 mm (3.5").
 - SBS modified bitumen membrane vapour barrier / Pare-vapeur elastomère thermofusible.
 - Structural concrete deck / Pontage de béton.

Roof Wind Loads / Charges de Vent:
 End zone width / Zone de coin, 4.755 ft (1.4 m)
 Corner / Coin, -42 psf (-2 kPa)
 Edge / Périphérie, -28 psf (-1.3 kPa)
 Field / Surface, -20 psf (-1 kPa)

 ROOF PLAN / PLAN DE TOITURE

KEY PLAN

GENERAL NOTES

1. THE GENERAL CONTRACTOR SHALL CHECK AND VERIFY ALL DIMENSIONS AND REPORT ALL ERRORS AND OMISSIONS TO THE PROJECT OFFICER.
2. ALL WORK AND MATERIALS TO BE IN COMPLIANCE WITH ALL CODES, REGULATIONS, AND BY-LAWS.
3. DO NOT SCALE DRAWINGS.
4. ALL DIMENSIONS ARE TO FINISHED FACES.

NO.	REVISION	DATE

PROJECT NAME:

BUILDING_22
RE-ROOFING

PROJECT NO:

PROJECT_NUMBER

DRAWING TITLE:

DETAILS

DRAWN BY:

SA

APPROVED BY:

??

PROJECT MANAGER: ADMIN. DE PROJETS:

WLADYSLAW_WRZENIEWSKI

DATE: DATE:

28/03/2014

SCALE: ECHELLE:

NTS

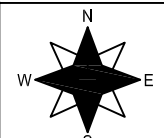

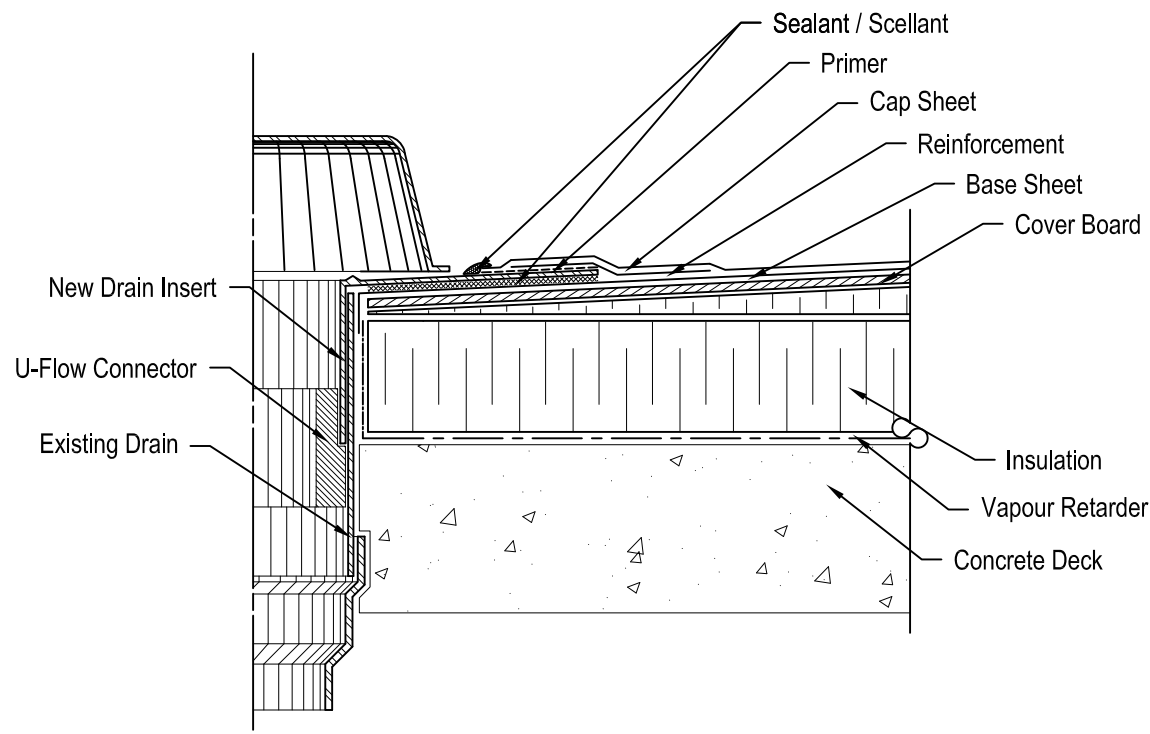
 DRAWING NO.
NO. DU DESSIN
2

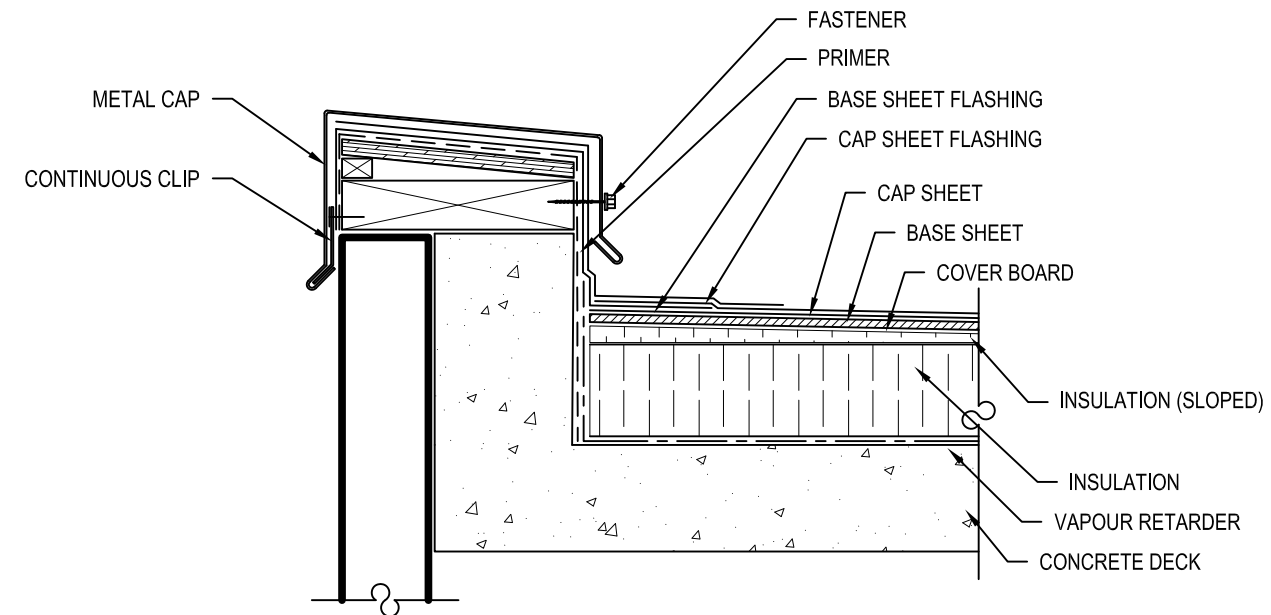

1 RETROFIT DRAIN
 1 SCALE: N.T.S.

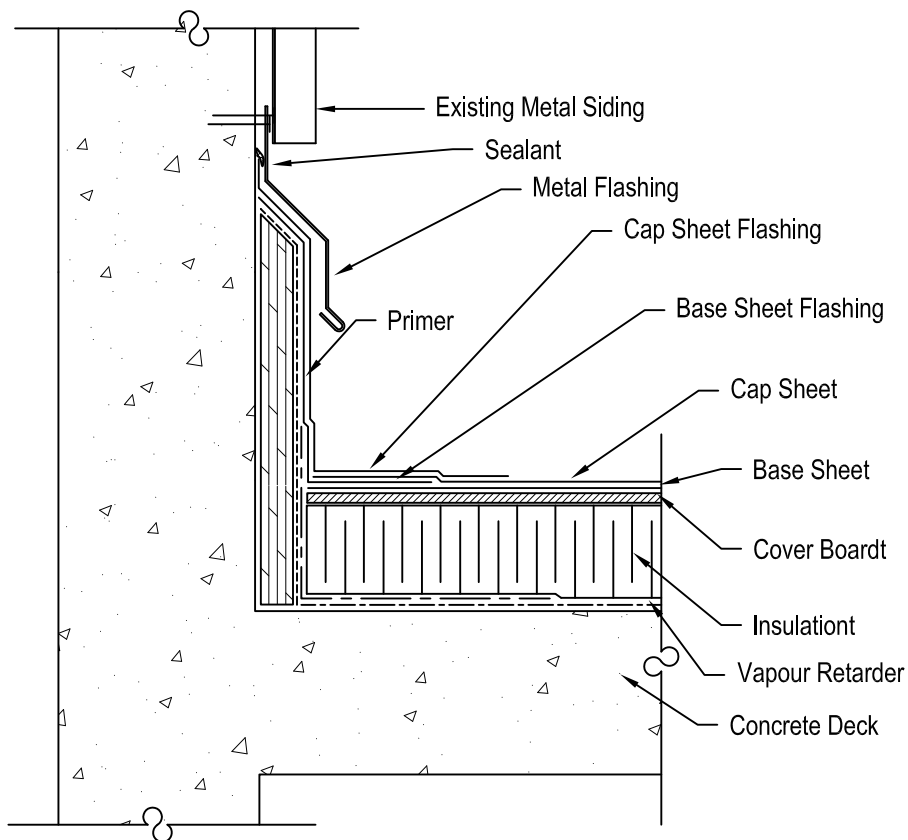

2 SHORT PARAPET DETAIL, CONCRETE DECK
 1 SCALE: N.T.S.



3 PENTHOUSE PERIMETER
 R1 SCALE: N.T.S.

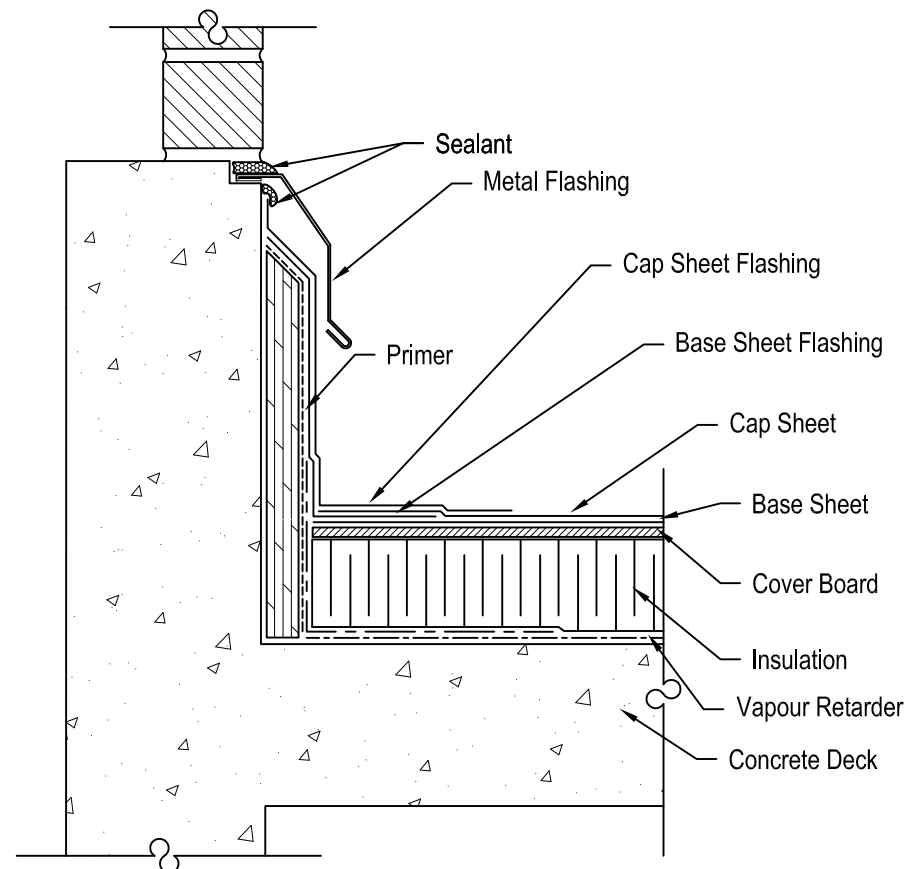

4 ROOF-PENTHOUSE WALL TERMINATION
 R1 SCALE: N.T.S.

KEY PLAN

GENERAL NOTES

1. THE GENERAL CONTRACTOR SHALL CHECK AND VERIFY ALL DIMENSIONS AND REPORT ALL ERRORS AND OMISSIONS TO THE PROJECT OFFICER.
2. ALL WORK AND MATERIALS TO BE IN COMPLIANCE WITH ALL CODES, REGULATIONS, AND BY-LAWS.
3. DO NOT SCALE DRAWINGS.
4. ALL DIMENSIONS ARE TO FINISHED FACES.

NO.	REVISION	DATE

PROJECT NAME:
BUILDING 22
RE-ROOFING

PROJECT NO:
PROJECT_NUMBER

DRAWING TITLE:
DETAILS

DRAWN BY:
SA

APPROVED BY:
??

PROJECT MANAGER: ADMIN. DE PROJETS:
WLADYSLAW_WRZENIEWSKI

DATE: 28/03/2014

SCALE: NTS

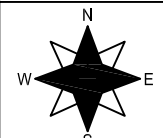
 DRAWING NO.
NO. DU DESSIN
3

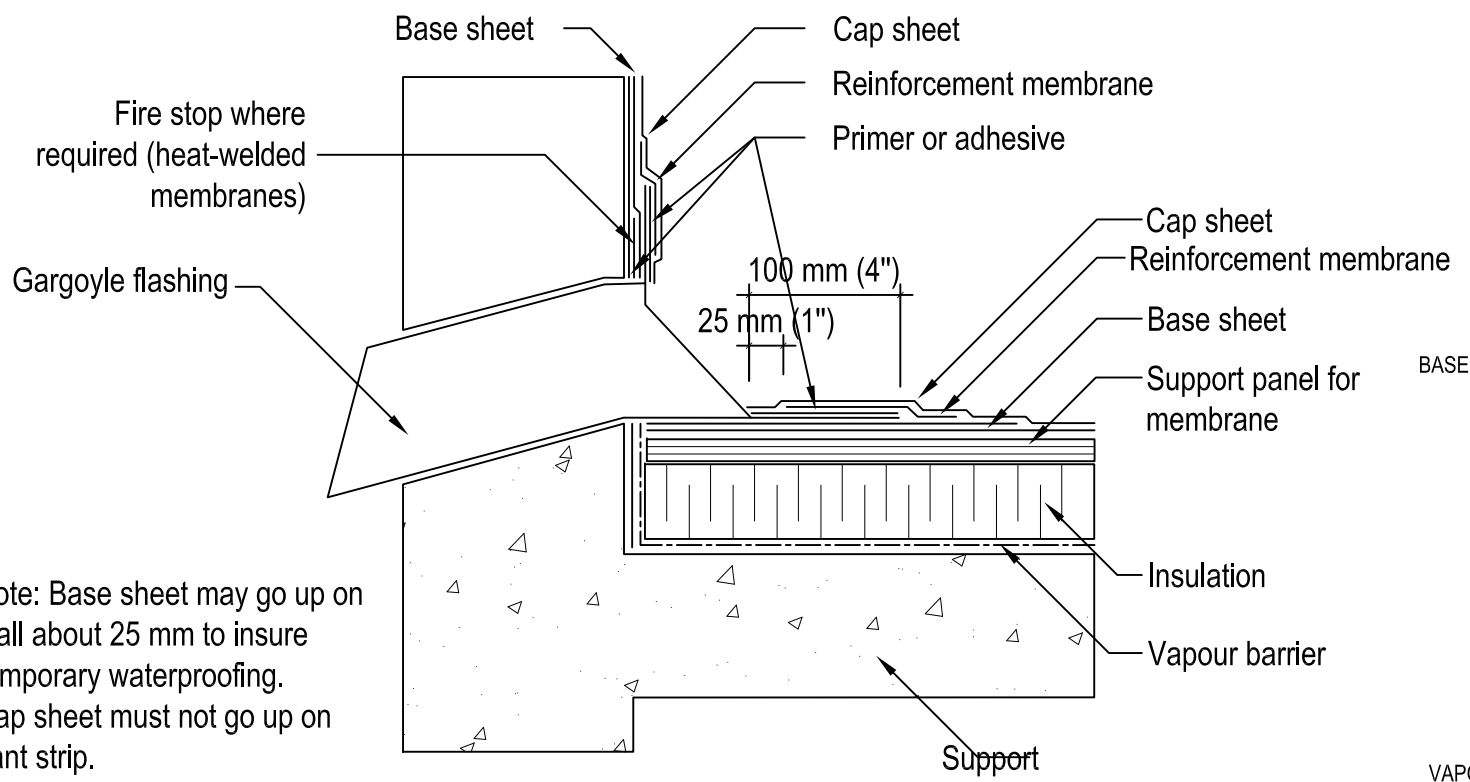

5 SCUPPER DETAIL
1 SCALE: N.T.S.

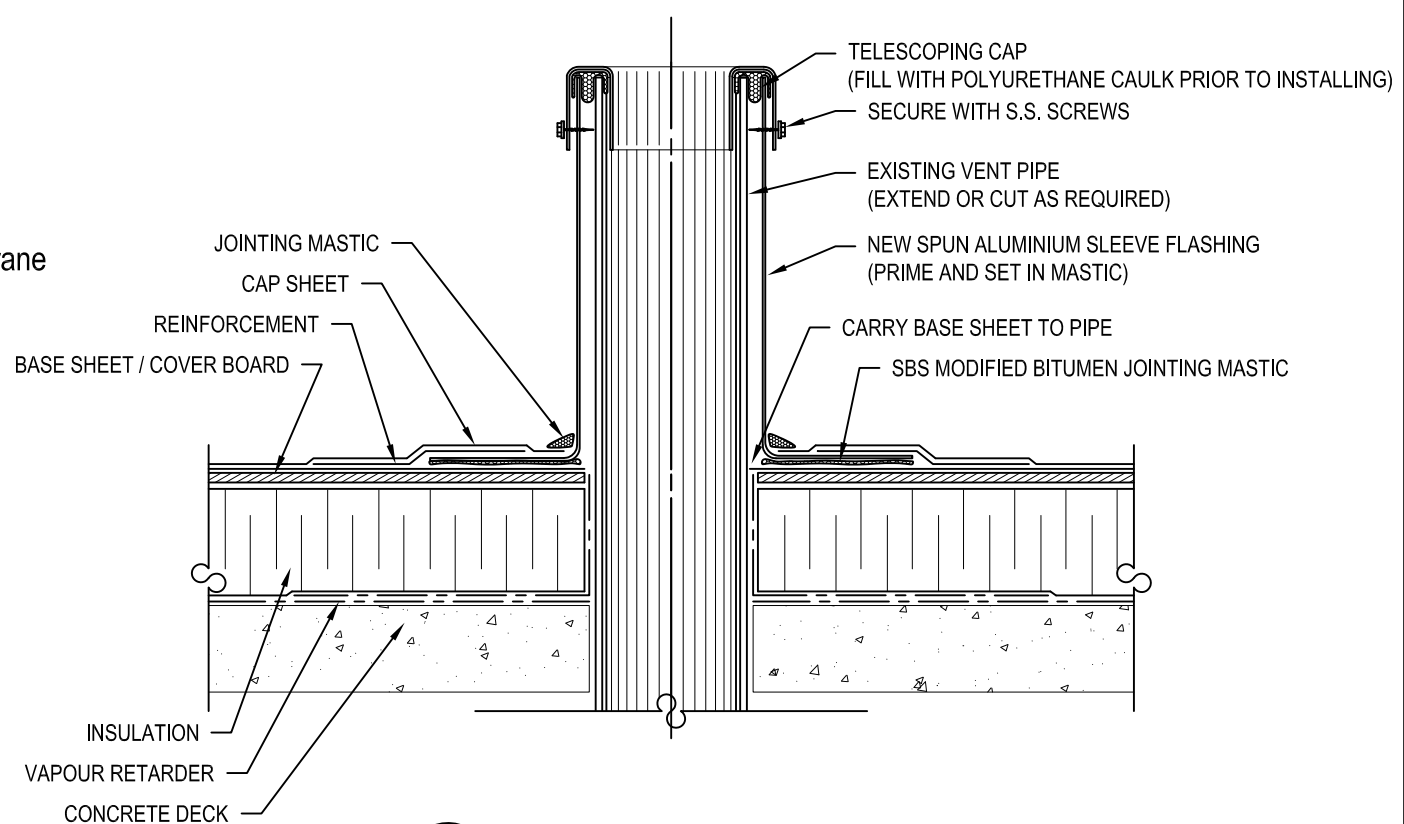

6 VENT STACK DETAIL
SCALE: N.T.S.

Note: Base sheet may go up on wall about 25 mm to insure temporary waterproofing. Cap sheet must not go up on cant strip.

8 SCUPPER DETAIL
1 SCALE: N.T.S.

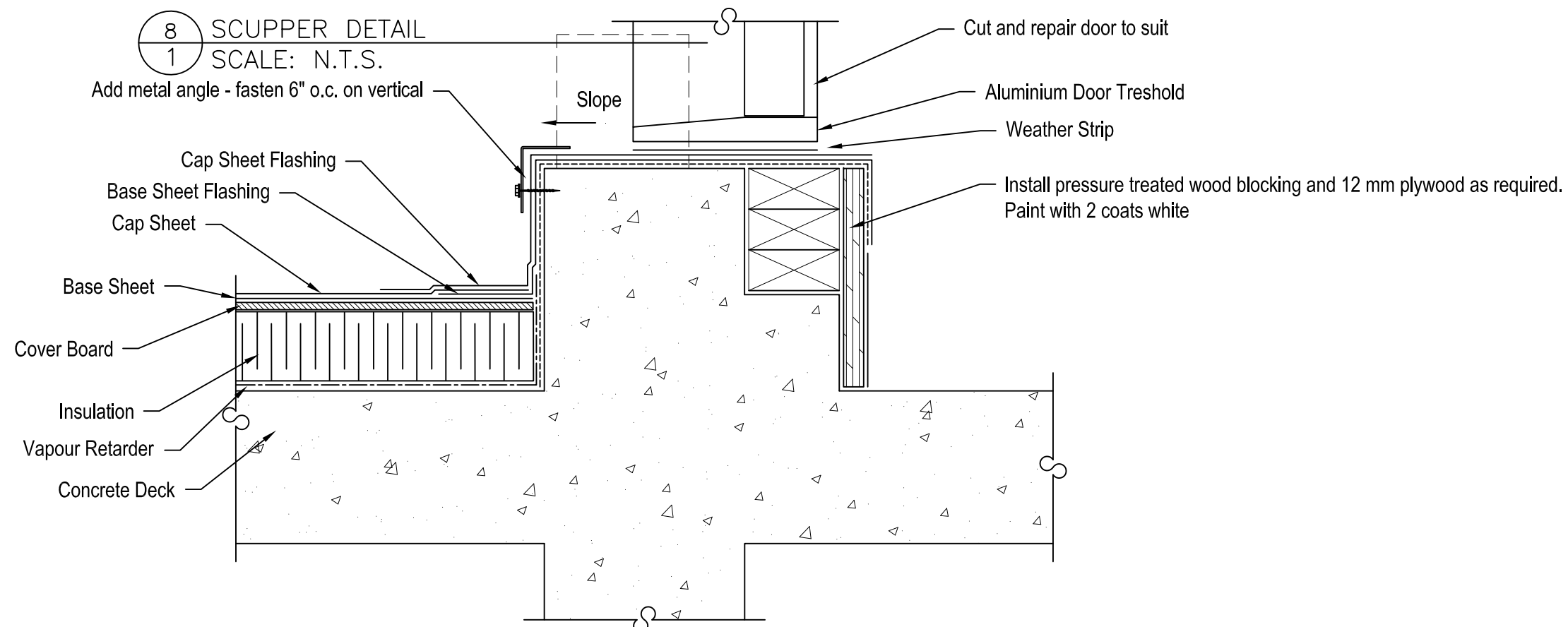

7 MEMBRANE TERMINATION AT DOOR
1 SCALE: N.T.S.

APPENDIX E:
PHOTOGRAPHIC DOCUMENTATION

1. Unit will be disconnected and reconnected.



2. Railings to be removed and reinstalled with liquid membrane flashing as sealing product at penetrations. Consultant to inspect for structural attachment requirements after removal. Where necessary railings to be cut to allow removal.



3. Step will be removed during the construction and reinstated upon completion.



4. Existing flashing on the roof anchor will remain. Roof to be terminated onto metal flashing. This work will be completed with liquid membrane flashing as sealing product.



5. Sleeper support/curb:

Remove all the metal and roof membrane to the substrate. New roofing membrane to be carried over curb. Use vibration pads beneath sleepers and bolt with angles as shown. Use liquid membrane to seal bolt penetrations.



6. Use new rain collar at all fan ducts.



7. All supports to be removed and reinstated. Use liquid membrane flashing as sealing product at all penetrations.



8. Install Interclip Pitch Pocket system at electrical penetrations.



9. Install C-Port pipe supports for cables and tie cable direct to support.



10. Repair duct waterproofing with Self-adhesive foil-faced membrane.



11. Remove and reinstall.



12. Switch to be re-secured. Use liquid membrane flashing as sealing product at penetrations.



13. When reinstalled, use Liquid membrane flashing as sealing product over the base.



14. Reinstall on the concrete paver with a Sopramat paver.



15. Install new wood sleepers with Sopramat



16. Reuse existing flashings.

