



Procurement and Contracting Services

30 Victoria Street, Gatineau, Québec K1A 0M6
proposition-proposal@elections.ca

REQUEST FOR PROPOSAL

The bidder, as identified below, hereby offers to sell to the Chief Electoral Officer of Canada, or any person authorized to act on his/her behalf, in accordance with the terms and conditions set out herein, referred to herein or attached hereto, the goods and services listed herein and on any attached sheets at the prices set out therefore.

Bidder's Name:
Address:
Tel No.:
Fax. No.:
IN WITNESS WHEREOF , this Request for Proposal has been duly executed on behalf of the bidder by the hands of its officer duly authorized in that behalf.

<i>signature of authorized signatory</i>

<i>print name of authorized signatory</i>

<i>print title of authorized signatory</i>
Date: _____

Office of the Chief Electoral Officer File No.
ECLP-RFP-14-0293

Title:	Date:
Elections Canada Poll Bags	July 31, 2014
Request for Proposal Closing Date:	
September 10, 2014 at 2:00pm (Gatineau Time)	

INQUIRIES – address inquiries to:	
Office of the Chief Electoral Officer of Canada Procurement and Contracting Services 30 Victoria Street, Gatineau, Québec K1A 0M6	
Attention:	Tel No.
Luc Potvin	819-939-1487
	E-mail:
	proposition-proposal@elections.ca

SUBMIT PROPOSALS TO:
Elections Canada Proposal Receiving Unit c/o Business Centre 30 Victoria Street, 1 st Floor Gatineau, Québec K1A 0M6
Attention: Luc Potvin
PROPOSALS TRANSMITTED BY FACSIMILE OR ELECTRONIC MAIL TO ELECTIONS CANADA WILL NOT BE ACCEPTED



REQUEST FOR PROPOSAL

**SOLICITATION NUMBER
ECLP-RFP-14-0293**

**Various Elections Canada Poll Bags
(as per Mandatory Specifications)**

**Enquiries closing date: September 2, 2014 at 2:00pm (Gatineau time)
Bid closing date: September 10, 2014 at 2:00pm (Gatineau time)**

This Request for Proposal (RFP) contains the following documents:

Part 1 – Annex A – Mandatory Tender Form

Part 2 – Annex B – Mandatory Specifications

Specifications # EC11530 (08-2014)

Specifications # EC50480 (08-2014)

Specifications # EC50490 (08-2014)

Specifications # EC50500 (08-2014)

Specifications # EC78791 (08-2014)

Part 3 – Annex C – General Conditions – Mixed Goods and Services

Part 4 – Annex D – Invoicing Instructions (successful bidder only)

Annex A

Mandatory Tender Form

IT IS MANDATORY THAT ANNEX A (ALL ITEMS BELOW) BE DULY AND FULLY COMPLETED. ALL ITEMS ARE TO BE PRICED BASED ON THE QUANTITIES SPECIFIED.

A – Description	B – Quantity	C – Unit Cost	D – Extended Cost
1. EC11530 – Loose Documents Bag – Beige	70,000 Loose Documents Bags (no overs, no underrun) (as per mandatory specifications)	\$ _____ (Unit cost)	\$ _____ (Extended cost)
2. EC50480 Advance Poll Bag – Light Green	15,000 Advance Poll Bags (no overs, no underrun) (as per mandatory specifications)	\$ _____ (Unit cost)	\$ _____ (Extended cost)
3. EC50490 – Mobile Poll Bag – Light Violet	10,000 Mobile Poll Bags (no overs, no underrun) (as per mandatory specifications)	\$ _____ (Unit cost)	\$ _____ (Extended cost)
4. EC50500 – Ordinary Poll Bag – Yellow	110,000 Ordinary Poll Bags (no overs, no underrun) (as per mandatory specifications)	\$ _____ (Unit cost)	\$ _____ (Extended cost)
5. EC78791 – Large Plastic Envelope for Return of National and Local Special Ballots – Cyan	2,200 Plastic Envelopes (no overs, no underrun) (as per mandatory specifications)	\$ _____ (Unit cost)	\$ _____ (Extended cost)

**TOTAL EXTENDED COST
– INITIAL DELIVERY**

\$ _____

SUM of lines D1 + D2 + D3 + D4 + D5

*****ALL PRICES ARE TO BE IN CANADIAN DOLLARS AND ARE TO REMAIN EXCLUSIVE OF HST, ALL APPLICABLE TAXES WILL BE ADDED TO YOUR COST.**

The price of bids will be evaluated in Canadian dollars, the Goods and Services Tax (GST) or the Harmonized Sales Tax (HST) excluded, FOB destination for goods, Customs duties and Excise taxes included.

MANDATORY DELIVERY DATES – INITIAL QUANTITIES

ITEM DESCRIPTION	MANDATORY DELIVERY DATES	BIDDER TO CONFIRM: YES/NO
EC11530 – Loose Documents Bag – Beige	Partial Delivery of 35,000: October 31, 2014 or sooner Final Delivery of 35,000: November 14, 2014 or sooner	
EC50480 Advance Poll Bag – Light Green	Final Delivery of 15,000: October 31, 2014 or sooner	
EC50490 – Mobile Poll Bag – Light Violet	Final Delivery of 10,000: October 31, 2014 or sooner	
EC50500 – Ordinary Poll Bag – Yellow	Partial Delivery of 40,000: October 31, 2014 or sooner Final Delivery of 70,000: November 14, 2014 or sooner	
EC78791 – Large Plastic Envelope for Return of National and Local Special Ballots – Cyan	Final Delivery of 2,200: October 31, 2014 or sooner	

OPTION 1 – 25% ADDITIONAL QUANTITIES

A – Description	B – Quantity	C – Unit Cost	D – Extended Cost
1. EC11530 – Loose Documents Bag – Beige	17,500 Loose Documents Bags (no overs, no underrun) (as per mandatory specifications)	\$ _____ (Unit cost)	\$ _____ (Extended cost)

2. EC50480 Advance Poll Bag – Light Green	3,750 Advance Poll Bags (no overs, no underrun) (as per mandatory specifications)	\$ _____ (Unit cost)	\$ _____ (Extended cost)
3. EC50490 – Mobile Poll Bag – Light Violet	2,500 Mobile Poll Bags (no overs, no underrun) (as per mandatory specifications)	\$ _____ (Unit cost)	\$ _____ (Extended cost)
4. EC50500 – Ordinary Poll Bag – Yellow	27,500 Ordinary Poll Bags (no overs, no underrun) (as per mandatory specifications)	\$ _____ (Unit cost)	\$ _____ (Extended cost)
5. EC78791 – Large Plastic Envelope for Return of National and Local Special Ballots – Cyan	550 Plastic Envelopes (no overs, no underrun) (as per mandatory specifications)	\$ _____ (Unit cost)	\$ _____ (Extended cost)
	TOTAL EXTENDED COST – OPTION 1	\$ _____ SUM of lines D1 + D2 + D3 + D4 + D5	

*****ALL PRICES ARE TO BE IN CANADIAN DOLLARS AND ARE TO REMAIN EXCLUSIVE OF HST, ALL APPLICABLE TAXES WILL BE ADDED TO YOUR COST.**

The price of bids will be evaluated in Canadian dollars, the Goods and Services Tax (GST) or the Harmonized Sales Tax (HST) excluded, FOB destination for goods, Customs duties and Excise taxes included.

OPTION 2 – 50% ADDITIONAL QUANTITIES

A – Description	B – Quantity	C – Unit Cost	D – Extended Cost
-----------------	--------------	---------------	-------------------

1. EC11530 – Loose Documents Bag – Beige	35,000 Loose Documents Bags (no overs, no underrun) (as per mandatory specifications)	\$ _____ (Unit cost)	\$ _____ (Extended cost)
2. EC50480 Advance Poll Bag – Light Green	7,500 Advance Poll Bags (no overs, no underrun) (as per mandatory specifications)	\$ _____ (Unit cost)	\$ _____ (Extended cost)
3. EC50490 – Mobile Poll Bag – Light Violet	5,000 Mobile Poll Bags (no overs, no underrun) (as per mandatory specifications)	\$ _____ (Unit cost)	\$ _____ (Extended cost)
4. EC50500 – Ordinary Poll Bag – Yellow	55,000 Ordinary Poll Bags (no overs, no underrun) (as per mandatory specifications)	\$ _____ (Unit cost)	\$ _____ (Extended cost)
5. EC78791 – Large Plastic Envelope for Return of National and Local Special Ballots – Cyan	1,100 Plastic Envelopes (no overs, no underrun) (as per mandatory specifications)	\$ _____ (Unit cost)	\$ _____ (Extended cost)
	TOTAL EXTENDED COST – OPTION 2	\$ _____	SUM of lines D1 + D2 + D3 + D4 + D5

TOTAL EVALUATED COST = SUM of INITIAL DELIVERY + OPTION 1 + OPTION 2 : \$ _____

*****ALL PRICES ARE TO BE IN CANADIAN DOLLARS AND ARE TO REMAIN EXCLUSIVE OF HST, ALL APPLICABLE TAXES WILL BE ADDED TO YOUR COST.**

The price of bids will be evaluated in Canadian dollars, the Goods and Services Tax (GST) or the Harmonized Sales Tax (HST) excluded, FOB destination for goods, Customs duties and Excise taxes included.

DELIVERY

The delivery dates are outlined in the attached specifications.

All delivery dates specified and quantities to be shipped are MANDATORY and will form part of any resultant contract. Please indicate your delivery schedule in the appropriate space (see Delivery Date Confirmation).

SPECIFICATIONS

The specifications attached as Annex B are MANDATORY – please consult with the specifications. Successful Bidder will be required to adhere to all items / processes / delivery dates specified within these specifications. Annex B will form part of any resulting contract.

OVERS

Items received by Elections Canada in excess of the allowable overage as stipulated in this specification are not to be invoiced. It is the Contractor's responsibility to ensure that items are not shipped in excess of the allowable overage.

It is **MANDATORY** that the bidders submit firm prices/rates and a delivery schedule for the item listed in Annex A above.

1. Elections Canada will evaluate the bids received and such evaluation will be based on the following factors:
 - a) the lowest total evaluated price for a technically compliant proposal to Elections Canada for the Work, having regard to qualifications, exceptions or alterations to the technical requirements – **only one proposal will be accepted and one contract will be issued to the successful Bidder;**
 - b) compliance with the terms and conditions of this bid solicitation;
 - c) Annex A – Mandatory Tender Form
 - d) Annex B – Mandatory Specifications
 - e) Annex C – General Conditions – Mixed Goods and Services;
 - f) Annex D – Invoicing Instructions (successful bidder only)
 - g) packaging;
 - h) label; and
 - i) shipping instructions

-
2. Elections Canada reserves the right to reject any bid which does not comply with this solicitation. Any deviation is to be clearly identified and supported with full details.
 3. Any bidder may be required to demonstrate to Elections Canada's satisfaction that it is capable of successfully completing the Work in accordance with this solicitation.
 4. To be considered responsive, a bid must meet all of the mandatory requirements of this solicitation. Bids not meeting all of the mandatory requirements will be given no further consideration. **The lowest priced responsive bid, based on the total evaluated price, will be recommended for award of a contract. The price used for the financial evaluation will be the total evaluated price which is calculated as follows: the sum of the Initial Delivery + Option 1 +Option 2.**

Contracting Authority

Luc Potvin
Advisor, Procurement and Contracting Services
Elections Canada
30 Victoria Street, 12th Floor
Gatineau, QC K1A 0M6
Email: proposition-proposal@elections.ca

GUIDELINES FOR BIDDERS

- The Contracting Authority will be the Bidder's primary contact with Elections Canada. All requests for information must be directed to this contact in writing or by Fax. Bidders who contact anyone other than the Contracting Authority will be disqualified. Elections Canada reserves the right to publish both questions and answers if deemed appropriate.
- This document is intended to provide the bidders with sufficient information to prepare a proposal. It is the bidder's responsibility to obtain any additional information from the Contracting Authority.
- Bidders will assume all responsibility and costs related to responding to this RFP.
- Elections Canada reserves the right to contract all or part of any bid or not award a contract as a result of this RFP.
- This RFP is confidential and the property of Elections Canada. Elections Canada must approve distribution or sharing of this document and will respect the confidentiality of proposals submitted by bidders.
- It is essential that the elements contained in your bid be stated in a clear and concise manner. Failure to provide complete information as requested will be to your disadvantage.
- If the Bidder feels that the terms and conditions of this solicitation will restrict it unnecessarily in any way, it should so state in its bid. Any deviations from the stipulated conditions should be given in detail with an explanation as to why they are being proposed. The Contracting Authority reserves the right to accept any bid as submitted without prior negotiations. It is the responsibility of the Bidder to obtain clarification of the requirements contained herein, if necessary, prior to submitting its bid.

-
- It is requested that proposals submitted in response to this RFP be signed by an authorized representative of the company in the space provided on the RFP;
 - After RFP closing date, no amendment to the proposals will be accepted; however, during the evaluation, members of the Evaluation Team may, at their discretion, submit questions or conduct interviews with bidders to obtain clarification.
 - Elections Canada reserves the right to cancel this RFP in its entirety or to revise any of the terms and conditions or requirements contained herein, prior to the Solicitation Closing Date/Time.
 - In the event of cancellation or a revision to the RFP all relevant information will be communicated in writing to all bidders receiving copies of the RFP prior to the Solicitation Closing Date/Time.
 - The Contracting Authority may extend the Solicitation Closing Date/Time in the event of a revision to the RFP.
 - Bidders interested in submitting a proposal may request an extension to the Solicitation Closing Date/Time by contacting the Contracting Authority. Elections Canada reserves the right to determine such a request.
 - While Elections Canada may enter into contract without negotiation, Elections Canada reserves the right to negotiate with bidders on any procurement.

BID CLOSING DATE

Proposals must be received no later than **September 10, 2014 at 2:00pm (Gatineau Time)**.

Proposals received after the stipulated closing date and time will not be accepted and will be returned unopened to the Bidder. If a late proposal must be opened to determine the name and/or address of the Bidder or the nature of the enclosure, a covering letter will be sent to explain the necessity of opening the proposal.

ENQUIRIES – SOLICITATION STAGE

All enquiries regarding the solicitation must be submitted in writing by e-mail at proposition-proposal@elections.ca to the Contracting Authority as early as possible, and no later than **September 2, 2014, at 2:00pm (Gatineau Time)**. Enquiries received after that time may not be answered prior to the closing date of the RFP.

CUSTOMS CLEARANCE

It is the responsibility of the Bidder to allow sufficient time to obtain customs clearance, where required, before the scheduled bid closing date and time. Delays related to the obtaining of customs clearance cannot be construed as "undue delay in the mail" and will not be accepted under the Late Bids Policy.

TERM OF CONTRACT

The term of any subsequent Contract shall be for the period commencing from date of Contract (September 2014) and ending March 31, 2015.

OPTION TO EXTEND THE CONTRACT

The Contractor will grant to Elections Canada the irrevocable option to extend the period of the Contract by **1** additional period of **1** year under the same terms and conditions.

It will be a fundamental term of any resulting Contract to respect and meet all production schedule requirements, stock requirements, etc. Failure to respect this Term of Contract may result in the subsequent Contractor being deemed in Default, as detailed herein.

Annex B

Mandatory Specifications

SPECIFICATIONS SHEET

DESCRIPTION OF DELIVERABLE:	EC11530 (08/2014) – Loose Documents Bag – Beige
REFERENCE NUMBER:	EC11530 (08/2014)
TITLE:	EC11530 (08/2014) – Loose Documents Bag – Beige
QUANTITY:	70,000
ADDITIONAL QUANTITY (OPTIONS):	<p>Elections Canada may require additional quantity within the period of the resulting contract. Specifications will remain unchanged.</p> <p>The supplier will grant to Elections Canada the irrevocable option to acquire the additional quantity at the prices stated in the resulting contract. The option may only be exercised by the Contracting Authority and will be evidenced, for administrative purposes only, through a contract amendment.</p> <p>Within the quotation, in addition to the cost for the initial quantity, please provide:</p> <ul style="list-style-type: none">• A separate unit cost for up to 25% of the original quantity for each item.• A separate unit cost for up to 50% of the original quantity for each item. <p>Elections Canada makes no guarantee that this option will be exercised during the period of the contract.</p>
EVALUATION:	Suppliers are advised that the contract will be awarded to the supplier with the best overall cost which will factor the unit cost(s) for the initial quantity and the optional quantity.
OVER:	<p><i>No over / No under</i></p> <p>Items received by Elections Canada in excess of the allowable overage as stipulated in this specification are not to be invoiced. It is the supplier's responsibility to ensure that items are not shipped in excess of the allowable overage</p>

- SIZE:**
- Metric: 46cm long plus 7cm flap. Total length with flap 53cm x 37cm wide open end
 - Imperial: 18" long plus 2.75" flap. Total length with flap 20.75" x 14.50" wide – open end.
- STYLE:**
- **Gusset:** 10.2 cm or 4" gusset at the bottom
 - **Air Holes:** Plastic bag must have 2 half- moon holes at the bottom, one on the left side and one on the right side
- FLAP:**
- The 7cm flap must have one strip of 2cm wide x 37cm long (2.75" flap has one strip ¾" wide x 14.5" long) of hot melt, permanent glue (5 to 7 mil thick) covered by a white 1" wide PE liner. The glue must be centered within the liner.
- PRINTING:**
- Prints two colours PMS 2309C - beige for bag – bleeds all sides
Text: Black one side no bleed – front only.
Print quality – Informational
- INK:**
- PMS 2309C beige for entire outside body of bag – bleeds all sides.
Black for text.
- STOCK:**
- High density polyethylene .5mil plastic – Co-extruded white outside, grey opaque inside.
- PRODUCTION:**
- Camera Ready Copy has to be set up printing flat length wise 99cm long x 37cm wide (38.75" long x 14.5" wide)
- PROOF:**
- One proof is required for approval before production. Please send to Elections Canada, FREM Directorate, 30 Victoria Street, 10th Floor, Gatineau QC. K1A 0M6. Attention: Mathieu Levillain
- PACKAGING:**
- Package 100 per corrugated box. Each box not to weigh more than 35 lbs. Clearly identify each box as to content in a minimum 20 pt. type size.

Label on Boxes:

EC 11530 (08/2014)
*Loose Documents Bag - beige /Sac de documents en
feuilles détachées - beige*
Qty/Qté 100

QUOTE SUBMISSION:

Your quotation must show cost per unit and must include the transportation fee.

If possible, please prepare your quotation on your company's letterhead or include it in your email when submitting your quotation. This is to ensure that your company's name is clearly linked to your quotation.

MANDATORY DELIVERY DATE:

- **Partial delivery of 35,000 on October 31st, 2014**
- **Final delivery of 35,000 on November 14th, 2014 or BEFORE**

SHIPPING INSTRUCTIONS:

Ship on non-returnable shipping skids 48" wide by 42" deep not to exceed 54" high stacking height. The material must be accessible by hand held hydraulic pallet movers.

SKIDS:

Brewery type skid – 4 way entry type, 48" wide by 42" deep, 3 stringers with three blocks, each running 48" long

NOTE: Items shipped to the Distribution Centre not on requested skids will not be accepted upon delivery.

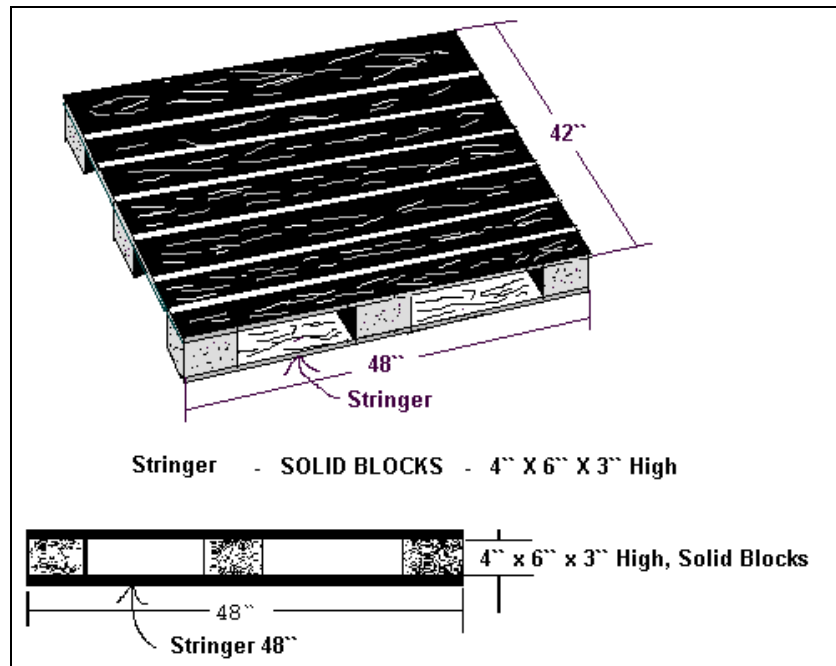

HOURS OF OPERATION :

8 a.m. to 12:00 noon / 1:00 p.m. to 4:00 p.m.

DESTINATION:

Elections Canada Distribution Centre
100-440 Coventry Road, Ottawa, Ontario K1K 2Y5

INVOICING:

Please send your invoice to the following address:

Jocelyne Leroux
SMS Team
Elections Canada
30 Victoria Street, Room 10-D-005
Gatineau, Quebec K1A 0M6

It is the responsibility of the supplier to provide a valid tax registration number for: HST/GST and QST, as applicable. Elections Canada will not validate tax registration numbers. If applicable sales taxes are invoiced without a tax registration number(s), Elections Canada will not pay the applicable sales tax(es).

Invoices must indicate the Contract number, if applicable, the Reference Number, the revision date and show any correction cost breakdown as applicable

ADDITIONAL INFORMATION:

No change in these specifications will be accepted unless approved



by the project authority.

Elections Canada must be informed of the cost of any author's alterations as soon as possible. A contract amendment must be made as soon as any changes affecting cost occur.

The printer is to return to Elections Canada a final electronic file properly identified with all or any corrections made at the proofing stage before invoices are approved for payment.

Wrapping and shipping instructions must be followed to the letter or the Distribution Centre may refuse to accept the shipment.

SPECIFICATIONS SHEET

DESCRIPTION OF DELIVERABLE: EC50480 (08/2014) – Advance Poll Bag – Light green

REFERENCE NUMBER: **EC50480 (08/2014)**

TITLE: EC50480 (08/2014) – Advance Poll Bag – Light green

QUANTITY: 15,000

ADDITIONAL QUANTITY (OPTION) Elections Canada may require additional quantity within the period of the resulting contract. Specifications will remain unchanged.

The supplier will grant to Elections Canada the irrevocable option to acquire the additional quantity at the prices stated in the resulting contract. The option may only be exercised by the Contracting Authority and will be evidenced, for administrative purposes only, through a contract amendment.

Within the quotation, in addition to the cost for the initial quantity, please provide:

- A separate unit cost for up to 25% of the original quantity for each item.
- A separate unit cost for up to 50% of the original quantity for each item.

Elections Canada makes no guarantee that this option will be exercised during the period of the contract.

EVALUATION: Suppliers are advised that the contract will be awarded to the supplier with the best overall cost which will factor the unit cost(s) for the initial quantity and the optional quantity.

OVER: ***No over / No under***
Items received by Elections Canada in excess of the allowable overage as stipulated in this specification are not to be invoiced. It is the supplier's responsibility to ensure that items are not shipped in excess of the allowable overage



- SIZE:**
- Metric: 46cm long plus 7cm flap. Total length with flap 53cm x 37cm wide open end
 - Imperial: 18" long plus 2.75" flap. Total length with flap 20.75" x 14.50" wide – open end.
- STYLE:**
- **Gusset:** 10.2 cm or 4" gusset at the bottom
 - **Air Holes:** Plastic bag must have 2 half- moon holes at the bottom, one on the left side and one on the right side
- FLAP:**
- The 7cm flap must have one strip of 2cm wide x 37cm long (2.75" flap has one strip ¾" wide x 14.5" long) of hot melt, permanent glue (5 to 7 mil thick) covered by a white 1" wide PE liner. The glue must be centered within the liner.
- PRINTING:**
- Prints two colours PMS 2253C Light Green for bag – bleeds all sides
Text: Black one side no bleed – front only.
Print quality – Informational
- INK:**
- PMS 2253C Light green for entire outside body of bag – bleeds all sides.
Black for text.
- STOCK:**
- High density polyethylene .5mil plastic – Co-extruded white outside, grey opaque inside
- PRODUCTION:**
- Camera Ready Copy has to be set up printing flat length wise 99cm long x 37cm wide (38.75" long x 14.5" wide)
- PROOF:**
- One proof is required for approval before production. Please send to Elections Canada, FREM Directorate, 30 Victoria Street, 10th Floor, Gatineau QC. K1A 0M6. Attention: Mathieu Levillain.
- PACKAGING:**
- Package 100 per corrugated box. Each box not to weigh more than 35 lbs. Clearly identify each box as to content in a minimum 20 pt. type size.

Label on Boxes:

EC 50480 (08/2014)
*Advance Poll Bag – Light Green/SAC pour BVA – vert
pale
Qty/Qté 100*

QUOTE SUBMISSION:

Your quotation must show cost per unit and must include the transportation fee.

If possible, please prepare your quotation on your company's letterhead or include it in your email when submitting your quotation. This is to ensure that your company's name is clearly linked to your quotation.

MANDATORY DELIVERY DATE:

October 31st, 2014, or sooner

SHIPPING INSTRUCTIONS:

Ship on non-returnable shipping skids 48" wide by 42" deep not to exceed 54" high stacking height. The material must be accessible by hand held hydraulic pallet movers.

SKIDS:

Brewery type skid – 4 way entry type, 48" wide by 42" deep, 3 stringers with three blocks, each running 48" long

NOTE: Items shipped to the Distribution Centre not on requested skids will not be accepted upon delivery.

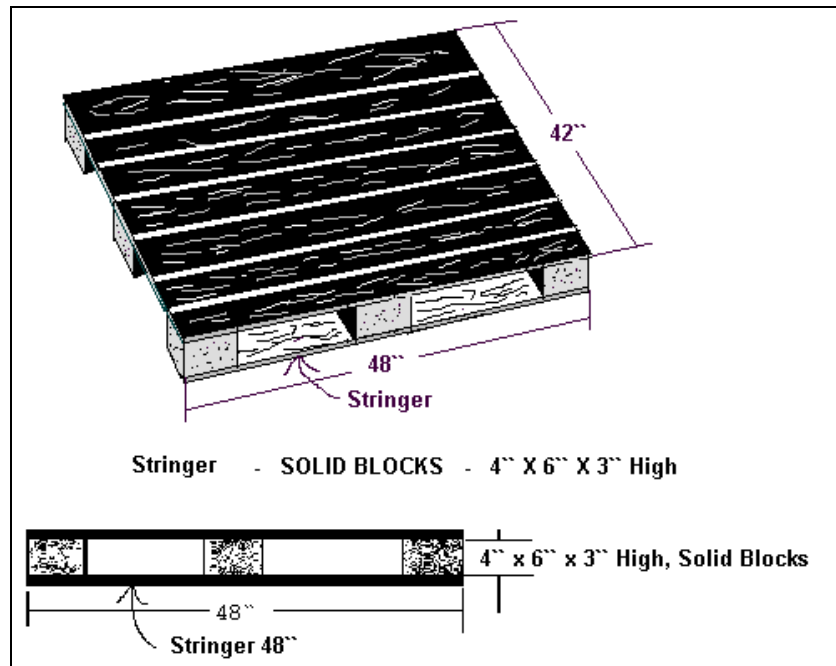

HOURS OF OPERATION :

8 a.m. to 12:00 noon / 1:00 p.m. to 4:00 p.m.

DESTINATION:

Elections Canada Distribution Centre
100-440 Coventry Road, Ottawa, Ontario K1K 2Y5

INVOICING:

Please send your invoice to the following address:

Jocelyne Leroux
SMS Team
Elections Canada
30 Victoria Street, Room 10-D-005
Gatineau, Quebec K1A 0M6

It is the responsibility of the supplier to provide a valid tax registration number for: HST/GST and QST, as applicable. Elections Canada will not validate tax registration numbers. If applicable sales taxes are invoiced without a tax registration number(s), Elections Canada will not pay the applicable sales tax(es).

Invoices must indicate the Contract number, if applicable, the Reference Number, the revision date and show any correction cost breakdown as applicable



ADDITIONAL INFORMATION:

No change in these specifications will be accepted unless approved by the project authority.

Elections Canada must be informed of the cost of any author's alterations as soon as possible. A contract amendment must be made as soon as any changes affecting cost occur.

The printer is to return to Elections Canada a final electronic file properly identified with all or any corrections made at the proofing stage before invoices are approved for payment.

Wrapping and shipping instructions must be followed to the letter or the Distribution Centre may refuse to accept the shipment.

SPECIFICATIONS SHEET

DESCRIPTION OF DELIVERABLE:	EC50490 (08/2014) – Mobile Poll Bag – Light Violet
REFERENCE NUMBER:	EC50490 (08/2014)
TITLE:	EC50490 (08/2014) – Mobile Poll Bag – Light Violet
INITIAL QUANTITY:	10,000
ADDITIONAL QUANTITY (OPTION):	<p>Elections Canada may require additional quantity within the period of the resulting contract. Specifications will remain unchanged.</p> <p>The supplier will grant to Elections Canada the irrevocable option to acquire the additional quantity at the prices stated in the resulting contract. The option may only be exercised by the Contracting Authority and will be evidenced, for administrative purposes only, through a contract amendment.</p> <p>Within the quotation, in addition to the cost for the initial quantity, please provide:</p> <ul style="list-style-type: none">• A separate unit cost for up to 25% of the original quantity for each item.• A separate unit cost for up to 50% of the original quantity for each item. <p>Elections Canada makes no guarantee that this option will be exercised during the period of the contract.</p>
EVALUATION:	Suppliers are advised that the contract will be awarded to the supplier with the best overall cost which will factor the unit cost(s) for the initial quantity and the optional quantity.
OVER:	<p><i>No over / No under</i></p> <p>Items received by Elections Canada in excess of the allowable overage as stipulated in this specification are not to be invoiced. It is the supplier's responsibility to ensure that items are not shipped in excess of the allowable overage</p>



- SIZE:**
- Metric: 46cm long plus 7cm flap. Total length with flap 53cm x 37cm wide open end
 - Imperial: 18" long plus 2.75" flap. Total length with flap 20.75" x 14.50" wide – open end.
- STYLE:**
- Gusset: 7.7 cm or 3" gusset at the bottom
 - **Air Holes:** Plastic bag must have 2 half- moon holes at the bottom, one on the left side and one on the right side
- FLAP:**
- The 7cm flap must have one strip of 2cm wide x 37cm long (2.75" flap has one strip ¾" wide x 14.5" long) of hot melt, permanent glue (5 to 7 mil thick) covered by a white 1" wide PE liner. The glue must be centered within the liner.
- PRINTING:**
- Prints two colours PMS 2645C -Light violet for bag– bleeds all sides
Text: Black one side no bleed – Front only
Print quality – Informational
- INK:**
- PMS 2645C – Light Violet for entire outside body of bag – bleeds all sides.
Black for text.
- STOCK:**
- High density polyethylene .5mil plastic – Co-extruded white outside, grey opaque inside.
- PRODUCTION:**
- Camera Ready Copy has to be set up printing flat length wise 99cm long x 37cm wide (38.75" long x 14.5" wide)
- PROOF:**
- One proof is required for approval before production. Please send to Elections Canada, FREM Directorate, 30 Victoria Street, 10th Floor, Gatineau QC. K1A 0M6. Attention: Mathieu Levillain
- PACKAGING:**
- Package 100 per corrugated box. Each box not to weigh more than 35 lbs. Clearly identify each box as to content in a minimum 20 pt. type size.

Label on Boxes:

EC 50490 (08/2014)
Mobile Poll Bag – Light Violet / Sac - bureau itinérant
– Violet pale
Qty/Qté 100

QUOTE SUBMISSION:

Your quotation must show a cost per unit for the initial quantity and if an additional quantity is specified a cost per unit for any option. All unit costs must include all associated transportation fees.

If possible, please prepare your quotation on your company's letterhead or include it in your email when submitting your quotation. This is to ensure that your company's name is clearly linked to your quotation.

MANDATORY DELIVERY DATE:

October 31st, 2014 or sooner

SHIPPING INSTRUCTIONS:

Ship on non-returnable shipping skids 48" wide by 42" deep not to exceed 54" high stacking height. The material must be accessible by hand held hydraulic pallet movers.

SKIDS:

Brewery type skid – 4 way entry type, 48" wide by 42" deep, 3 stringers with three blocks, each running 48" long

NOTE: Items shipped to the Distribution Centre not on requested skids will not be accepted upon delivery.

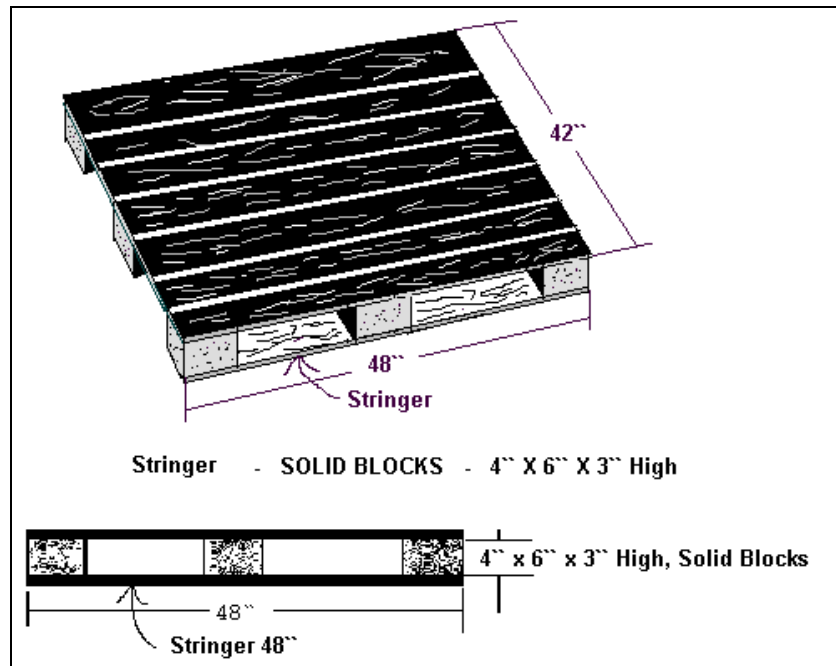

HOURS OF OPERATION :

8 a.m. to 12:00 noon / 1:00 p.m. to 4:00 p.m.

DESTINATION:

*Elections Canada Distribution Centre
100-440 Coventry Road, Ottawa, Ontario K1K 2Y5*

INVOICING:

Please send your invoice to the following address:

Jocelyne Leroux
SMS Team
Elections Canada
30 Victoria Street, Room 10-D-005
Gatineau, Quebec K1A 0M6

It is the responsibility of the supplier to provide a valid tax registration number for: HST/GST and QST, as applicable. Elections Canada will not validate tax registration numbers. If applicable sales taxes are invoiced without a tax registration number(s), Elections Canada will not pay the applicable sales tax(es).

Invoices must indicate the Contract number, if applicable, the Reference Number, the revision date and show any correction cost breakdown as applicable

ADDITIONAL INFORMATION:

No change in these specifications will be accepted unless approved



by the project authority.

Elections Canada must be informed of the cost of any author's alterations as soon as possible. A contract amendment must be made as soon as any changes affecting cost occur.

The printer is to return to Elections Canada a final electronic file properly identified with all or any corrections made at the proofing stage before invoices are approved for payment.

Wrapping and shipping instructions must be followed to the letter or the Distribution Centre may refuse to accept the shipment.

SPECIFICATIONS SHEET

DESCRIPTION OF DELIVERABLE:	EC50500 – Ordinary Poll Bag – Yellow
REFERENCE NUMBER:	EC50500 (08/2014)
TITLE:	EC50500 – Ordinary Poll Bag – Yellow
INITIAL QUANTITY:	110,000
ADDITIONAL QUANTITY (OPTION):	<p>Elections Canada may require additional quantity within the period of the resulting contract. Specifications will remain unchanged.</p> <p>The supplier will grant to Elections Canada the irrevocable option to acquire the additional quantity at the prices stated in the resulting contract. The option may only be exercised by the Contracting Authority and will be evidenced, for administrative purposes only, through a contract amendment.</p> <p>Within the quotation, in addition to the cost for the initial quantity, please provide:</p> <ul style="list-style-type: none">• A separate unit cost for up to 25% of the original quantity for each item.• A separate unit cost for up to 50% of the original quantity for each item. <p>Elections Canada makes no guarantee that this option will be exercised during the period of the contract.</p>
EVALUATION:	Suppliers are advised that the contract will be awarded to the supplier with the best overall cost which will factor the unit cost(s) for the initial quantity and the optional quantity.
OVER:	<p><i>No over / No under</i></p> <p>Items received by Elections Canada in excess of the allowable overage as stipulated in this specification are not to be invoiced. It is the supplier's responsibility to ensure that items are not shipped in excess of the allowable overage</p>



- SIZE:**
- Metric: 46cm long plus 7cm flap. Total length with flap 53cm x 37cm wide open end
 - Imperial: 18" long plus 2.75" flap. Total length with flap 20.75" x 14.50" wide – open end.
- STYLE:**
- Gusset: 7.7 cm or 3" gusset at the bottom
 - **Air Holes:** Plastic bag must have 2 half- moon holes at the bottom, one on the left side and one on the right side
- FLAP:**
- The 7cm flap must have one strip of 2cm wide x 37cm long (2.75" flap has one strip ¾" wide x 14.5" long) of hot melt, permanent glue (5 to 7 mil thick) covered by a white 1" wide PE liner. The glue must be centered within the liner.
- PRINTING:**
- Prints two colours PMS 120C Yellow for bag – bleeds all sides
Text: Black one side no bleed – front only.
Print quality – Informational
- INK:**
- PMS 120C Yellow for entire outside body of bag – bleeds all sides.
Inside bag to be coated with a grey screen to ensure security of documents.
Black for text.
- STOCK:**
- High density polyethylene .5mil plastic – Co-extruded white outside, grey opaque inside.
- PRODUCTION:**
- Camera Ready Copy has to be set up printing flat length wise 99cm long x 37cm wide (38.75" long x 14.5" wide)
- PROOF:**
- One proof is required for approval before production. Please send to Elections Canada, FREM Directorate, 30 Victoria Street, 10th Floor, Gatineau QC. K1A 0M6. Attention: Mathieu Levillain
- PACKAGING:**
- Package 100 per corrugated box. Each box not to weigh more than 35 lbs. Clearly identify each box as to content in a minimum 20 pt. type size.

Label on Boxes:

EC 50500 (08/2014)
Ordinary Poll Bag - Yellow /Sac jaune pour BVO
Qty/Qté 100

QUOTE SUBMISSION:

Your quotation must show a cost per unit for the initial quantity and if an additional quantity is specified a cost per unit for any option. All unit costs must include all associated transportation fees.

If possible, please prepare your quotation on your company's letterhead or include it in your email when submitting your quotation. This is to ensure that your company's name is clearly linked to your quotation.

MANDATORY DELIVERY DATES:

- **First partial delivery of 40,000 on October 31st, 2014**
- **Second partial delivery of 70,000 at the latest on November 14th, 2014**

SHIPPING INSTRUCTIONS:

Ship on non-returnable shipping skids 48" wide by 42" deep not to exceed 54" high stacking height. The material must be accessible by hand held hydraulic pallet movers.

SKIDS:

Brewery type skid – 4 way entry type, 48" wide by 42" deep, 3 stringers with three blocks, each running 48" long

NOTE: Items shipped to the Distribution Centre not on requested skids will not be accepted upon delivery.

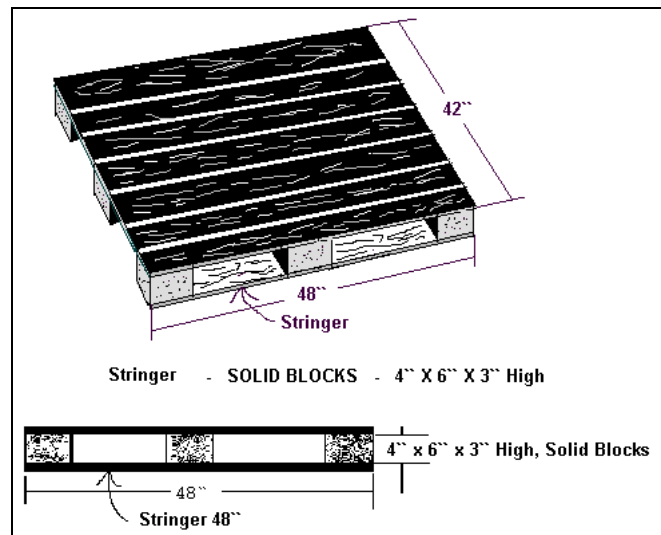

HOURS OF OPERATION :

8 a.m. to 12:00 noon / 1:00 p.m. to 4:00 p.m.

DESTINATION:

Elections Canada Distribution Centre



100-440 Coventry Road, Ottawa, Ontario K1K 2Y5

INVOICING:

Please send your invoice to the following address:

Jocelyne Leroux
SMS Team
Elections Canada
30 Victoria Street, Room 10-D-005
Gatineau, Quebec K1A 0M6

It is the responsibility of the supplier to provide a valid tax registration number for: HST/GST and QST, as applicable. Elections Canada will not validate tax registration numbers. If applicable sales taxes are invoiced without a tax registration number(s), Elections Canada will not pay the applicable sales tax(es).

Invoices must indicate the Contract number, if applicable, the Reference Number, the revision date and show any correction cost breakdown as applicable

ADDITIONAL INFORMATION:

No change in these specifications will be accepted unless approved by the project authority.

Elections Canada must be informed of the cost of any author's alterations as soon as possible. A contract amendment must be made as soon as any changes affecting cost occur.

The printer is to return to Elections Canada a final electronic file properly identified with all or any corrections made at the proofing stage before invoices are approved for payment.

Wrapping and shipping instructions must be followed to the letter or the Distribution Centre may refuse to accept the shipment.

SPECIFICATIONS SHEET

DESCRIPTION OF DELIVERABLE:	EC78791 – Large Plastic Envelope for Return of National and Local Special Ballots – Cyan
REFERENCE NUMBER:	EC78791 (08/2014)
TITLE:	EC78791 – Large Plastic Envelope for Return of National and Local Special Ballots – Cyan
INITIAL QUANTITY:	2,200
ADDITIONAL QUANTITY (OPTION):	<p>Elections Canada may require additional quantity within the period of the resulting contract. Specifications will remain unchanged.</p> <p>The supplier will grant to Elections Canada the irrevocable option to acquire the additional quantity at the prices stated in the resulting contract. The option may only be exercised by the Contracting Authority and will be evidenced, for administrative purposes only, through a contract amendment.</p> <p>Within the quotation, in addition to the cost for the initial quantity, please provide:</p> <ul style="list-style-type: none">• A separate unit cost for up to 25% of the original quantity for each item.• A separate unit cost for up to 50% of the original quantity for each item. <p>Elections Canada makes no guarantee that this option will be exercised during the period of the contract.</p>
EVALUATION:	Suppliers are advised that the contract will be awarded to the supplier with the best overall cost which will factor the unit cost(s) for the initial quantity and the optional quantity.
OVER:	<p><i>No over / No under</i></p> <p>Items received by Elections Canada in excess of the allowable overage as stipulated in this specification are not to be invoiced. It is the supplier's responsibility to ensure that items are not shipped in excess of the allowable overage</p>



- SIZE:**
- Metric: 46cm long plus 7cm flap. Total length with flap 53cm x 37cm wide open end
 - Imperial: 18" long plus 2.75" flap. Total length with flap 20.75" x 14.50" wide – open end.
- STYLE:**
- Gusset: 7.7 cm or 3" gusset at the bottom
 - **Air Holes:** Plastic bag must have 2 half- moon holes at the bottom, one on the left side and one on the right side
- FLAP:**
- The 7cm flap must have one strip of 2cm wide x 37cm long (2.75" flap has one strip ¾" wide x 14.5" long) of hot melt, permanent glue (5 to 7 mil thick) covered by a white 1" wide PE liner. The glue must be centered within the liner.
- PRINTING:**
- Prints two colours PMS 2225U Yellow for bag – bleeds all sides
Text: Black one side no bleed – front only.
Print quality – Informational
- INK:**
- PMS 120C Yellow for entire outside body of bag – bleeds all sides.
Inside bag to be coated with a grey screen to ensure security of documents.
Black for text.
- STOCK:**
- High density polyethylene .5mil plastic – Co-extruded white outside, grey opaque inside.
- PRODUCTION:**
- Camera Ready Copy has to be set up printing flat length wise 99cm long x 37cm wide (38.75" long x 14.5" wide)
- PROOF:**
- One proof is required for approval before production. Please send to Elections Canada, FREM Directorate, 30 Victoria Street, 10th Floor, Gatineau QC. K1A 0M6. Attention: Mathieu Levillain



PACKAGING:

Package 100 per corrugated box. Each box not to weigh more than 35 lbs. Clearly identify each box as to content in a minimum 20 pt. type size.

Label on Boxes:

EC 78791 (08/2014)
Large Cyan plastic envelope for return of national and
local special ballots / Enveloppe plastique Cyan pour
bulletins nationaux et locaux
Qty/Qté 100

QUOTE SUBMISSION:

Your quotation must show a cost per unit for the initial quantity and if an additional quantity is specified a cost per unit for any option. All unit costs must include all associated transportation fees.

If possible, please prepare your quotation on your company's letterhead or include it in your email when submitting your quotation. This is to ensure that your company's name is clearly linked to your quotation.

MANDATORY DELIVERY DATE:

October 31st, 2014 or sooner

SHIPPING INSTRUCTIONS:

Ship on non-returnable shipping skids 48" wide by 42" deep not to exceed 54" high stacking height. The material must be accessible by hand held hydraulic pallet movers.

SKIDS:

Brewery type skid – 4 way entry type, 48" wide by 42" deep, 3 stringers with three blocks, each running 48" long

NOTE: Items shipped to the Distribution Centre not on requested skids will not be accepted upon delivery.

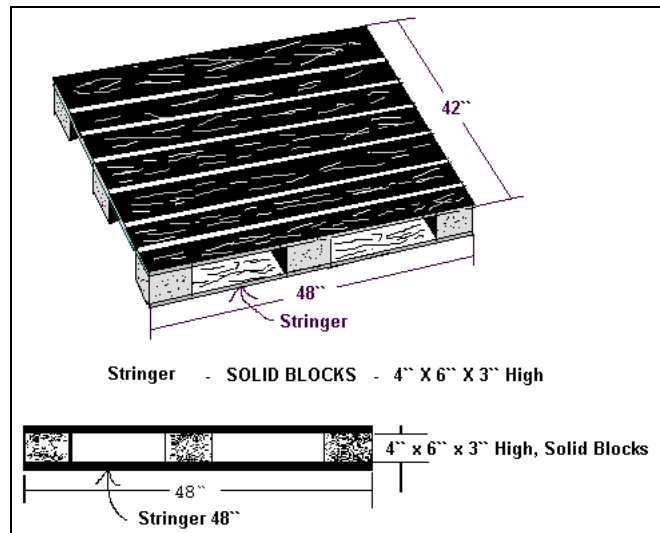

HOURS OF OPERATION :

8 a.m. to 12:00 noon / 1:00 p.m. to 4:00 p.m.

DESTINATION:

Elections Canada Distribution Centre
100-440 Coventry Road, Ottawa, Ontario K1K 2Y5



INVOICING:

Please send your invoice to the following address:

Jocelyne Leroux
SMS Team
Elections Canada
30 Victoria Street, Room 10-A-005
Gatineau, Quebec K1A 0M6

It is the responsibility of the supplier to provide a valid tax registration number for: HST/GST and QST, as applicable. Elections Canada will not validate tax registration numbers. If applicable sales taxes are invoiced without a tax registration number(s), Elections Canada will not pay the applicable sales tax(es).

Invoices must indicate the contract number, if applicable, the EC reference number, the revision date and show any correction cost breakdown, as applicable.

ADDITIONAL INFORMATION:

No change in these specifications will be accepted unless approved by the technical authority.

Elections Canada must be informed of the cost of any author's alterations as soon as possible. A contract amendment must be made as soon as any changes affecting cost occur.

The supplier is to return to Elections Canada a final electronic file properly identified with all or any corrections made at the proofing stage before invoices are approved for payment.

Wrapping and shipping instructions must be followed to the letter or the Distribution Centre may refuse to accept the shipment.

Appendix C

General Conditions – Mixed Goods & Services

Annex C
General Conditions
Mixed Goods and Services

Article 1 Interpretation

Section 1.01 Definitions

1.01.01 In the Contract, unless the context otherwise requires:

- “Articles of Agreement” means the clauses and conditions incorporated in full text in the body of the Contract; it does not include these general conditions, any supplemental general conditions, annexes, the Contractor’s bid or any other document;
- “Canada” means Her Majesty the Queen in right of Canada;
- “Contract” means the Articles of Agreement, these general conditions, any supplemental general conditions, annexes and any other document specified or referred to as forming part of the Contract, all as amended by agreement of the Parties from time to time;
- “Contracting Authority” means the person designated by that title in the Contract, or by notice to the Contractor, to act as Elections Canada’s representative to manage the Contract;
- “Contractor” means the person, entity or entities named in the Contract to supply goods, services or both to Elections Canada;
- “Contract Price” means the amount stated in the Contract to be payable to the Contractor for the Work, exclusive of applicable sales tax;
- “Cost” means cost determined according to Contract Cost Principles 1031-2 as revised to the date of the bid solicitation or, if there was no bid solicitation, the date of the Contract.
- “EC Property” means anything supplied to the Contractor by or on behalf of Elections Canada for the purposes of performing the Contract and anything acquired by the Contractor in any manner in connection with the Work, the cost of which is paid by Elections Canada under the Contract;
- “Elections Canada” means the Chief Electoral Officer and any other person duly

authorized to act on his behalf;

“Party”	means Elections Canada, the Contractor, or any other signatory to the Contract and "Parties" means all of them;
“Specifications”	means the description of the essential, functional or technical requirements of the Work in the Contract, including the procedures for determining whether the requirements have been met; and
“Work”	means all the activities, services, goods, equipment, matters and things required to be done, delivered or performed by the Contractor under the Contract.

Section 1.02 Powers of Elections Canada

All rights, remedies, powers and discretions granted or acquired by Elections Canada under the Contract or by law are cumulative, not exclusive.

Section 1.03 Status of the Contractor

The Contractor is an independent contractor engaged by Elections Canada to perform the Work. Nothing in the Contract is intended to create a partnership, a joint venture or an agency between Elections Canada and the other Party or Parties. The Contractor must not represent itself as an agent or representative of Elections Canada to anyone. Neither the Contractor nor any of its personnel is engaged as an employee or agent of Elections Canada. The Contractor is responsible for all deductions and remittances required by law in relation to its employees.

Section 1.04 Severability

If any provision of the Contract is declared by a court of competent jurisdiction to be unenforceable, that provision is to be either adjusted the minimum necessary to make it enforceable (if permitted by law) or stricken (if not). If adjusting or striking the unenforceable provision would result in failure of an essential purpose of this agreement, the entire agreement is to be held unenforceable. After an unenforceable provision is adjusted or stricken in accordance with this Section 1.04, the rest of the Contract is to remain in effect as written and the unenforceable provision is to remain as written in any circumstances other than those in which the provision is held to be unenforceable.

Section 1.05 Entire Agreement

The Contract constitutes the entire and only agreement between the Parties and supersedes all previous negotiations, communications and other agreements, whether written or oral, unless they are incorporated by reference in the Contract. There are no terms, covenants, representations, statements or conditions binding on the Parties other than those contained in the Contract.

Article 2 Conduct of the Work

Section 2.01 Representation and Warranties

2.01.01 The Contractor represents and warrants that:

- (a) it is competent to perform the Work;
- (b) it has everything necessary to perform the Work, including the resources, facilities, labour, technology, equipment, and materials; and
- (c) it has the necessary qualifications, including knowledge, skill, know-how and experience, and the ability to use them effectively to perform the Work.

2.01.02 The Contractor must:

- (a) perform the Work diligently and efficiently;
- (b) except for EC Property, supply everything necessary to perform the Work;
- (c) use, as a minimum, quality assurance procedures, inspections and controls generally used and recognized by the industry to ensure the degree of quality required by the Contract; and
- (d) ensure that the Work is of proper quality, using appropriate material and workmanship and meets all the requirements of the Contract.

2.01.03 Unless the Contracting Authority orders the Contractor to suspend the Work or part of the Work pursuant to Article 19 (Suspension of Work), the Contractor must not stop or suspend the Work or part of the Work pending the settlement of any dispute between the Parties about the Contract.

2.01.04 The Contractor must provide all reports that are required by the Contract and any other information that Elections Canada may reasonably require from time to time.

2.01.05 The Contractor is fully responsible for performing the Work. Elections Canada will not be responsible for any negative consequences or extra costs if the Contractor follows any advice given by Elections Canada unless the Contracting Authority provides the advice to the Contractor in writing and includes a statement specifically relieving the Contractor of any responsibility for negative consequences or extra costs that might result from following the advice.

Article 3 Work

Section 3.01 Specification

3.01.01 All Specifications provided by Elections Canada or on behalf of Elections Canada to the

Contractor in connection with the Contract belong to Elections Canada and must be used by the Contractor only for the purpose of performing the Work.

- 3.01.02 If the Contract provides that Specifications furnished by the Contractor must be approved by Elections Canada, that approval will not relieve the Contractor of its responsibility to meet all requirements of the Contract.

Section 3.02 Condition of Material

- 3.02.01 Unless provided otherwise in the Contract, material supplied must be new and conform to the latest issue of the applicable drawing, specifications and part number that is in effect on the bid closing date or, if there was no bid solicitation, the date of the Contract.

Section 3.03 Replacement of Specific Individuals

- 3.03.01 If specific individuals are identified in the Contract to perform the Work, the Contractor must provide the services of those individuals unless the Contractor is unable to do so for reasons beyond its control.
- 3.03.02 If the Contractor is unable to provide the services of any specific individual identified in the Contract, it must provide a replacement with similar qualifications and experience. The replacement must meet the criteria used in the selection of the Contractor and be acceptable to Elections Canada. The Contractor must, as soon as possible, give notice to the Contracting Authority of the reason for replacing the individual and provide:
- (a) the name, qualifications and experience of the proposed replacement; and
 - (b) proof that the proposed replacement has the required security clearance granted by Elections Canada or Canada, if applicable.
- 3.03.03 Upon receiving the notice of replacement of a specific individual, if the Contracting Authority determines that the replacement is acceptable to Elections Canada, the Contracting Authority shall send a written notice to the Contractor confirming its acceptance of the replacement.
- 3.03.04 The Contractor must not, in any event, allow performance of the Work by unauthorized replacement persons. The Contracting Authority may order that a replacement stop performing the Work. In such a case, the Contractor must immediately comply with the order and secure a further replacement in accordance with Subsection 3.03.02. The fact that the Contracting Authority does not order that a replacement stop performing the Work does not relieve the Contractor from its responsibility to meet the requirements of the Contract.

Section 3.04 Inspection and Acceptance of the Work

- 3.04.01 All the Work is subject to inspection and acceptance by Elections Canada. Inspection and

acceptance of the Work by Elections Canada do not relieve the Contractor of its responsibility for defects or other failures to meet the requirements of the Contract. Elections Canada will have the right to reject any work that is not in accordance with the requirements of the Contract and require its correction or replacement at the Contractor's expense.

- 3.04.02 The Contractor must provide representatives of Elections Canada access to all locations where any part of the Work is being performed at any time during working hours. Representatives of Elections Canada may make examinations and such tests of the Work as they may think fit. The Contractor must provide all assistance and facilities, test pieces, samples and documentation that the representatives of Elections Canada may reasonably require for the carrying out of the inspection. The Contractor must forward such test pieces and samples to such person or location as Elections Canada specifies.
- 3.04.03 The Contractor must inspect and approve any part of the Work before submitting it for acceptance or delivering it to Elections Canada. The Contractor must keep accurate and complete inspection records that must be made available to Elections Canada on request. Representatives of Elections Canada may make copies and take extracts of the records during the performance of the Contract and for up to three years after the end of the Contract.

Section 3.05 Time of the Essence

It is essential that the Work be delivered within or at the time stated in the Contract.

Article 4 Subcontracts

Section 4.01 Consent

- 4.01.01 Except as provided in Subsection 4.01.02, the Contractor must obtain the Contracting Authority's written consent before subcontracting or permitting the subcontracting of any part of the Work. A subcontract includes a contract entered into by any subcontractor at any tier to perform any part of the Work.
- 4.01.02 The Contractor is not required to obtain consent for subcontracts specifically authorized in the Contract. The Contractor may also without the consent of the Contracting Authority:
- (a) purchase "off-the-shelf" items and any standard articles and materials that are ordinarily produced by manufacturers in the normal course of business;
 - (b) subcontract any services that form part of the Work if it is customary in the carrying out of similar contracts; and
 - (c) with respect to goods or part thereof to be delivered as part of the work, subcontract any part or parts of the Work to one or more subcontracts up to a total value of 40 percent of the Contract Price; and;

- (d) permit its subcontractors at any tier to make purchases or subcontract as permitted in Paragraphs (a) and (b).

Section 4.02 Subcontractor to be bound by Contract

- 4.02.01 In any subcontract other than a subcontract referred to in Paragraph 4.01.02(a), the Contractor must, unless the Contracting Authority agrees in writing, ensure that the subcontractor is bound by conditions compatible with and, in the opinion of the Contracting Authority, not less favourable to Elections Canada than the conditions of the Contract.
- 4.02.02 Even if Elections Canada consents to a subcontract, the Contractor is responsible for performing the Contract and Elections Canada is not responsible to any subcontractor. The Contractor is responsible for any matters or things done or provided by any subcontractor under the Contract and for paying any subcontractors for any part of the Work they perform.

Article 5 Harassment in the Workplace

Section 5.01 No tolerance

The Contractor must not, either as an individual, or as a corporate or unincorporated entity, through its employees or subcontractors, harass, abuse, threaten, discriminate against or intimidate any employee, contractor or other individual employed by, or under contract with Elections Canada. The Contractor will be advised in writing of any complaint and will have the right to respond in writing. Upon receipt of the Contractor's response, the Contracting Authority will, at its entire discretion, determine if the complaint is founded and decide on any action to be taken, which action may be termination of the Contract by reason of default by the Contractor.

Article 6 Payment

Section 6.01 Invoice Submission

- 6.01.01 Invoices must be submitted in the Contractor's name. The Contractor must submit invoices for each delivery or shipment; invoices must only apply to the Contract. Each invoice must indicate whether it covers partial or final delivery.
- 6.01.02 Invoices must show:
 - (a) the date, the name and address of Elections Canada, item or reference numbers, deliverable and/or description of the Work, contract number, Procurement Business Number (PBN), the Contractor's business number for tax remission purposes, and financial code(s);
 - (b) details of expenditures in accordance with the basis of payment provision in the

Articles of Agreement, exclusive of applicable sales tax (such as item, quantity, unit of issue, unit price, fixed time labour rates and level of effort, subcontracts, as applicable);

(c) deduction for holdback, if applicable;

(d) the extension of the totals, if applicable; and

(e) if applicable, the method of shipment together with date, case numbers and part or reference numbers, shipment charges and any other additional charges.

6.01.03 Applicable sales tax must be specified on all invoices as a separate item together with the corresponding registration number issued by the appropriate tax authority. All items that are zero-rated, exempt or to which no sales tax applies, must be identified as such on all invoices.

6.01.04 By submitting an invoice, the Contractor certifies that the invoice is consistent with the Work delivered and is in accordance with the Contract.

Section 6.02 Payment Period

6.02.01 Provided that Elections Canada has received a duly signed original copy of the Contract, Elections Canada's standard payment period is 30 days. The payment period will commence the date the invoice, in acceptable form and content, is received in accordance with the Contract or the date the Work is delivered in acceptable condition as required in the Contract, whichever is later. A payment is considered overdue on the 31st day following that date and interest will be paid automatically in accordance with Section 6.04.

6.02.02 If the content of the invoice and its substantiating documentation are not in accordance with the Contract or the Work is not in acceptable condition, Elections Canada will notify the Contractor within 15 days of receipt. The 30-day payment period begins upon receipt of the revised invoice or replacement invoice or the Work being corrected. Failure by Elections Canada to notify the Contractor within 15 days will only result in the date specified in Subsection 6.02.01 to apply for the sole purpose of calculating interest on overdue accounts.

Section 6.03 Withholding of Payment

6.03.01 Where a delay referred to in Article 18 – Excusable Delay has occurred, Elections Canada may, at Elections Canada's discretion, withhold all or a portion of any payment due to the Contractor until a "work-around" plan approved by Elections Canada has been implemented in accordance with Section 18.01. Section 6.04 shall not apply to any amount withheld under this Subsection.

Section 6.04 Interest on Overdue Accounts

6.04.01 For the purpose of this Section:

“Average Rate” means the simple arithmetic mean of the Bank Rates in effect at 4:00 p.m. Eastern Time each day during the calendar month immediately before the calendar month in which payment is made;

“Bank Rate” means the rate of interest established from time to time by the Bank of Canada as the minimum rate at which the Bank of Canada makes short term advances to members of the Canadian Payments Association;

“date of payment” means the date of the negotiable instrument drawn by the Receiver General for Canada to pay any amount under the Contract; and

an amount becomes “overdue” when it is unpaid on the first day following the day on which it is due and payable according to the Contract.

6.04.02 Elections Canada will pay to the Contractor simple interest at the Average Rate plus 3 percent per year on any amount that is overdue, from the date that amount becomes overdue until the day before the date of payment, inclusive. The Contractor is not required to provide notice to Elections Canada for interest to be payable.

6.04.03 Elections Canada will pay interest in accordance with this Section only if Elections Canada is responsible for the delay in paying the Contractor. Elections Canada will not pay interest on overdue advance payments.

Article 7 Accounts and Audit

Section 7.01 Accounts and Audit

7.01.01 The Contractor must keep proper accounts and records of the cost of performing the Work and of all expenditures or commitments made by the Contractor in connection with the Work, including all invoices, receipts and vouchers. The Contractor must retain records, including bills of lading and other evidence of transportation or delivery, for all deliveries made under the Contract.

7.01.02 If the Contract includes payment for time spent by the Contractor, its employees, representatives, agents or subcontractors performing the Work, the Contractor must keep a record of the actual time spent each day by each individual performing any part of the Work.

7.01.03 Unless Elections Canada has consented in writing to its disposal, the Contractor must retain all the information described in this Section for six years after it receives the final payment under the Contract, or until the settlement of all outstanding claims and disputes, whichever is later. During this time, the Contractor must make this information available for audit, inspection and examination by the representatives of Elections Canada, who may make copies and take extracts. The Contractor must provide all reasonably required

facilities for any audit and inspection and must furnish all the information as the representatives of Elections Canada may from time to time require to perform a complete audit of the Contract.

- 7.01.04 The amount claimed under the contract, calculated in accordance with the basis of payment provision in the Articles of Agreement, is subject to audit both before and after payment is made. If an audit is performed after payment, the Contractor agrees to repay any overpayment immediately on demand by Elections Canada. Elections Canada may hold back, deduct and set off any credits owing and unpaid under this Section from any money that Elections Canada owes to the Contractor at any time (including under other contracts). If Elections Canada does not choose to exercise this right at any given time, Elections Canada does not lose this right.

Article 8 Taxes

Section 8.01 Municipal Taxes

Municipal Taxes do not apply.

Section 8.02 Provincial Taxes Exemption

- 8.02.01 Except as provided by law, Elections Canada is not required to pay any sales tax payable to the province in which the taxable goods or services are delivered. This exemption has been provided to federal government departments and agencies under the authority of one of the following:

(a) Provincial Sales Tax (PST) Exemption Licence Numbers, for the provinces of:

- i. British Columbia PST-1000-5001;
- ii. Manitoba 390-516-0;

(b) for Saskatchewan, the Yukon Territory, the Northwest Territories and Nunavut, an Exemption certification, which certifies that the goods or services purchased by Elections Canada are not subject to the provincial and territorial sales and consumption taxes because they are purchased by a federal government department or agency with Canada funds for the use of Elections Canada.

- 8.02.02 Currently, in Alberta, the Yukon Territory, the Northwest Territories and Nunavut, there is no general PST. However, if a PST is introduced in Alberta, the Yukon Territory, the Northwest Territories or Nunavut, PST will be payable unless an exemption certification is included in the purchasing document.

Section 8.03 Harmonized Sales Tax

Elections Canada must pay the HST in the participating provinces of Newfoundland and Labrador, Nova Scotia, New Brunswick, Ontario and Prince Edward Island.

Section 8.04 Quebec Sales Tax

Elections Canada must pay the Quebec Sales Tax in the province of Quebec.

Section 8.05 Provincial Taxes paid by the Contractor

The Contractor is not exempt from paying PST under the above Exemption Licence Numbers or Exemption Certification. The Contractor must pay the PST on taxable goods or services used or consumed in the performance of the Contract (in accordance with applicable provincial legislation), including material incorporated into real property.

Section 8.06 Changes to Taxes and Duties

8.06.01 If there is any change to any tax or duty payable to any level of government in Canada after the bid submission date that affects the costs of the Work to the Contractor, the Contract Price will be adjusted to reflect the increase or decrease in the cost to the Contractor.

8.06.02 However, there will be no adjustment for any change that increases the cost of the Work to the Contractor if public notice of the change was given before bid submission date in sufficient detail to have permitted the Contractor to calculate the effect of the change on its cost. There will be no adjustment if the change takes effect after the date required by the Contract for delivery of the Work.

Section 8.07 Applicable Sales Tax

The estimated amount of applicable sales tax is included in the total estimated cost on page 1 of the Contract. The applicable sales tax is not included in the Contract Price but will be paid by Elections Canada as provided in the Invoice Submission Section above. The Contractor agrees to remit to the appropriate government agency any amounts of applicable sales tax paid or due.

Section 8.08 Tax Withholding of 15 Percent

Pursuant to the *Income Tax Act*, 1985, c. 1 (5th Supp.) and the *Income Tax Regulations*, Elections Canada must withhold 15 percent of the amount to be paid to the Contractor in respect of services provided in Canada if the Contractor is a non-resident unless the Contractor obtains a valid waiver. The amount withheld will be held on account for the Contractor in respect to any tax liability which may be owed to Canada.

Article 9 Transportation Costs and Carriers' Liability

Section 9.01 Transportation Costs and Carriers' Liability

9.01.01 If transportation costs are payable by Elections Canada under the Contract and the Contractor makes the transportation arrangements, shipments must be made by the most direct and economical means consistent with normal shipping practice. The costs must be

shown as a separate item on the invoice.

- 9.01.02 In light of the federal government's policy of underwriting its own risks, Elections Canada is precluded to pay for insurance or valuation charges for transportation beyond the point at which ownership of goods passes to it (determined by the FOB point or Incoterms). Where increased carrier liability is available without charge, the Contractor must obtain the increased liability for shipment.

Article 10 Shipment Documentation

For the shipment of goods, the transportation bill of lading must accompany the original invoice, except for "collect" shipments (if and when stipulated), in which event it must accompany the shipment. In addition, a packing slip must accompany each shipment, showing item, quantity, part or reference numbers, description of the goods and contract number, including the PBN. If the goods have been inspected at the Contractor's plant, the signed inspection voucher must be attached to the packing slip normally enclosed in the packing note envelope.

Article 11 Ownership

- 11.01.01 Unless provided otherwise in the Contract, the Work or any part of the Work belongs to Elections Canada after delivery and acceptance by or on behalf of Elections Canada.
- 11.01.02 However if any payment is made to the Contractor for or on account of any Work, either by way of progress or milestone payments, that Work paid for by Elections Canada belongs to Elections Canada upon such payment being made. This transfer of ownership does not constitute acceptance by Elections Canada of the Work or any part of the Work and does not relieve the Contractor of its obligation to perform the Work in accordance with the Contract.
- 11.01.03 Despite any transfer of ownership, the Contractor is responsible for any loss or damage to the Work or any part of the Work until it is delivered to Elections Canada in accordance with the Contract. Even after delivery, the Contractor remains responsible for any loss or damage to any part of the Work caused by the Contractor or any subcontractor.
- 11.01.04 Upon transfer of ownership to the Work or any part of the Work to Elections Canada, the Contractor must, if requested by Elections Canada, establish to Elections Canada's satisfaction that the title is free and clear of all claims, liens, attachments, charges or encumbrances. The Contractor must execute any conveyances and other instruments necessary to perfect the title that Elections Canada may require.

Article 12 Elections Canada Property

- 12.01.01 All EC Property must be used by the Contractor solely for the purpose of the Contract and remains the property of Elections Canada. The Contractor must maintain adequate accounting records of all EC Property and, whenever feasible, mark it as being the property of Elections Canada.

- 12.01.02 The Contractor must take reasonable and proper care of all EC Property while it is in its possession or subject to its control. The Contractor is responsible for any loss or damage resulting from its failure to do so other than loss or damage caused by ordinary wear and tear.
- 12.01.03 All EC Property, unless it is installed or incorporated in the Work, must be returned to Elections Canada on demand. All scrap and all waste materials, articles or things that are EC Property must, unless provided otherwise in the Contract, remain the property of Elections Canada and must be disposed of only as directed by Elections Canada.
- 12.01.04 At the time of completion of the Contract, and if requested by the Contracting Authority, the Contractor must provide to Elections Canada an inventory of all EC Property relating to the Contract.

Article 13 Warranty

- 13.01.01 Despite inspection and acceptance of the Work by or on behalf of Elections Canada and without restricting any other provision of the Contract or any condition, warranty or provision imposed by law, the Contractor warrants that, for 12 months (or any other period stated in the Contract), the Work will be free from all defects in design, material or workmanship, and will conform to the requirements of the Contract. The warranty period begins on the date of delivery, or if acceptance takes place at a later date, the date of acceptance. With respect to EC Property not supplied by the Contractor, the Contractor's warranty will extend only to its proper incorporation into the Work.
- 13.01.02 In the event of a defect or non-conformance in any part of the Work during the warranty period, the Contractor, at the request of Elections Canada to do so, must as soon as possible repair, replace or otherwise make good at its own option and expense the part of the Work found to be defective or not in conformance with the requirements of the Contract.
- 13.01.03 The Work or any part of the Work found to be defective or non-conforming will be returned to the Contractor's plant for replacement, repair or making good. However, when in the opinion of Elections Canada it is not expedient to remove the Work from its location, the Contractor must carry out any necessary repair or making good of the Work at that location. In such cases, the Contractor will be paid the fair and reasonable Cost (including reasonable travel and living expenses) incurred in so doing, with no allowance for profit, less an amount equal to the Cost of rectifying the defect or non-conformance at the Contractor's plant.
- 13.01.04 Elections Canada must pay the transportation cost associated with returning the Work or any part of the Work to the Contractor's plant pursuant to Subsection 13.01.03. The Contractor must pay the transportation cost associated with forwarding the replacement or returning the Work or part of the Work when rectified to the delivery point specified in the Contract or to another location directed by Elections Canada.

- 13.01.05 The Contractor must remedy all data and reports pertaining to any correction or replacement under this Section, including revisions and updating of all affected data, manuals, publications, software and drawings called for under the Contract, at no cost to Elections Canada.
- 13.01.06 If the Contractor fails to fulfill any obligation described in this Section within a reasonable time of receiving a notice, Elections Canada will have the right to remedy or to have remedied the defective or non-conforming work at the Contractor's expense. If Elections Canada does not wish to correct or replace the defective or non-conforming work, an equitable reduction will be made in the Contract Price.
- 13.01.07 The warranty period is automatically extended by the duration of any period or periods where the Work is unavailable for use or cannot be used because of a defect or non-conformance during the original warranty period. The warranty applies to any part of the Work repaired, replaced or otherwise made good pursuant to Subsection 13.01.02, for the greater of:
- (a) the warranty period remaining, including the extension, or
 - (b) ninety days or such other period as may be specified for that purpose by agreement between the Parties.

Article 14 Liability

The Contractor is liable for any damage caused by the Contractor, its employees, subcontractors or agents to Elections Canada or any third party. Elections Canada is liable for any damage caused by Elections Canada, its employees or agents to the Contractor or any third party. The Parties agree that no limitation of liability or indemnity provision applies to the Contract unless it is specifically incorporated in full text in the Articles of Agreement or specifically provided for in supplemental general conditions, which form part of the Contract. Damage includes any injury to persons (including injury resulting in death) or loss of or damage to property (including real property) caused as a result of or during the performance of the Contract.

Article 15 Confidentiality

- 15.01.01 The Contractor must keep confidential all information provided or made available to the Contractor by or on behalf of Elections Canada in connection with the Work, including any information that is confidential or proprietary to third parties, and all information conceived, developed or produced by the Contractor as part of the Work when copyright or any other intellectual property rights in such information belongs to Elections Canada under the Contract (collectively, the "EC Information"). The Contractor must not disclose any EC Information without the written permission of Elections Canada. The Contractor may disclose to a subcontractor any EC Information as long as the subcontractor agrees to keep such EC Information confidential and that it will be used only to perform the subcontract.

- 15.01.02 The Contractor agrees to use the EC Information only for the purpose of the Contract. The Contractor acknowledges that all EC Information remains the property of Elections Canada or the third party, as the case may be. Unless provided otherwise in the Contract, the Contractor must deliver to Elections Canada all such EC Information, together with every copy, draft, working paper and note that contains such information, upon completion or termination of the Contract or at such earlier time as Elections Canada may require.
- 15.01.03 Subject to the *Access to Information Act*, R.S.C. 1985, c. A-1, and to any right of Elections Canada under the Contract to release or disclose, Elections Canada must not release or disclose outside the Government of Canada any information delivered to Elections Canada under the Contract that is proprietary to the Contractor or a subcontractor.
- 15.01.04 The obligations of the Parties set out in this Article do not apply to any information if the information:
- (a) is publicly available from a source other than the other Party; or
 - (b) is or becomes known to a Party from a source other than the other Party, except any source that is known to be under an obligation to the other Party not to disclose the information; or
 - (c) is developed by a Party without use of the information of the other Party.
- 15.01.05 Wherever possible, the Contractor must mark or identify any proprietary information delivered to Elections Canada under the Contract as “Property of (Contractor’s name), permitted Government uses defined under Elections Canada Contract No. (fill in Contract Number)”. Elections Canada will not be liable for any unauthorized use or disclosure of information that could have been so marked or identified and was not.
- 15.01.06 If the Contract, the Work, or any information referred to in Subsection 15.01.01 is identified as TOP SECRET, SECRET, CONFIDENTIAL, or PROTECTED by Elections Canada, the Contractor must at all times take all measures reasonably necessary for the safeguarding of the material so identified, including those set out in the PWGSC Industrial Security Manual and its supplements and any other instructions issued by Canada.
- 15.01.07 If the Contract, the Work, or any information referred to in Subsection 15.01.01 is identified as TOP SECRET, SECRET, CONFIDENTIAL, or PROTECTED, by Elections Canada, representatives of Elections Canada are entitled to inspect the Contractor’s premises and the premises of a subcontractor at any tier for security purposes at any time during the term of the Contract. The Contractor must comply with, and ensure that any subcontractor complies with, all written instructions issued by Elections Canada dealing with the material so identified, including any requirement that employees of the Contractor or of any subcontractor execute and deliver declarations relating to reliability screenings, security clearances and other procedures.

Section 15.02 An Oath of Secrecy

The Parties hereby agree to sign any document that is necessary for the execution of this Contract, including but not limited to, an oath of secrecy pertaining to information contained in the Register of Electors, lists of electors and/or any record placed under the responsibility and/or owned by Elections Canada.

Article 16 Copyright

Section 16.01 Copyright

- 16.01.01 In this Section, “Material” means anything that is created by the Contractor as part of the Work under the Contract, that is required by the Contract to be delivered to Elections Canada and in which copyright subsists. “Material” does not include anything created by the Contractor before the date of the Contract.
- 16.01.02 Copyright in the Material belongs to Elections Canada and the Contractor must include the copyright symbol and either of the following notice on the Material: © Her Majesty the Queen in right of Canada (year) or © Sa Majesté la Reine du chef du Canada (année).
- 16.01.03 The Contractor must not use, copy, divulge or publish any Material except as is necessary to perform the Contract. The Contractor must execute any conveyance and other documents relating to copyright in the Material as Elections Canada may require.
- 16.01.04 The Contractor must provide at the request of Elections Canada a written permanent waiver of moral rights, in a form acceptable to Elections Canada, from every author that contributed to the Material. If the Contractor is the author of the Material, the Contractor permanently waives its moral rights in the Material.

Section 16.02 Use and Translation of Documentation

The Contractor agrees that Elections Canada may translate in the other official language any documentation delivered to Elections Canada by the Contractor that does not belong to Elections Canada under Section 16.01. The Contractor acknowledges that Elections Canada owns the translation and that it is under no obligation to provide any translation to the Contractor. Elections Canada agrees that any translation must include any copyright notice and any proprietary right notice that was part of the original. Elections Canada acknowledges that the Contractor is not responsible for any technical errors or other problems that may arise as a result of the translation.

Article 17 Intellectual Property Infringement and Royalties

- 17.01.01 The Contractor represents and warrants that, to the best of its knowledge, neither it nor Elections Canada will infringe any third party’s intellectual property rights in performing or using the Work, and that Elections Canada will have no obligation to pay royalties of any kind to anyone in connection with the Work.

17.01.02 If anyone makes a claim against Elections Canada or the Contractor concerning intellectual property infringement or royalties related to the Work, that Party agrees to notify the other Party in writing immediately. If anyone brings a claim against Elections Canada, Elections Canada may either defend the claim or may request that the Contractor defend Elections Canada against the claim. In either case, the Contractor agrees to participate fully in the defence and any settlement negotiations and to pay all costs, damages and legal costs incurred or payable as a result of the claim, including the amount of any settlement. Both Parties agree not to settle any claim unless the other Party first approves the settlement in writing.

17.01.03 The Contractor has no obligation regarding claims that were only made because:

- (a) Elections Canada modified the Work or part of the Work without the Contractor's consent or used the Work or part of the Work without following a requirement of the Contract;
- (b) Elections Canada used the Work or part of the Work with a product that the Contractor did not supply under the Contract (unless that use is described in the Contract or the manufacturer's specifications);
- (c) the Contractor used equipment, drawings, specifications or other information supplied to the Contractor by Elections Canada (or by someone authorized by Elections Canada); or
- (d) the Contractor used a specific item of equipment or software that it obtained because of specific instructions from the Contracting Authority; however, this exception only applies if the Contractor has included the following language in its own contract with the supplier of that equipment or software:

“[Supplier name] acknowledges that the purchased items will be used by the Elections Canada. If a third party claims that equipment or software supplied under this contract infringes any intellectual property right, [supplier name], if requested to do so by either [Contractor name] or Elections Canada, will defend both [Contractor name] and Elections Canada against that claim at its own expense and will pay all costs, damages and legal fees payable as a result of that infringement.”

Obtaining this protection from the supplier is the Contractor's responsibility and, if the Contractor does not do so, it will be responsible to Elections Canada for the claim.

17.01.04 If anyone claims that, as a result of the Work, the Contractor or Elections Canada is infringing its intellectual property rights, the Contractor must immediately do one of the following:

- (a) take whatever steps are necessary to allow Elections Canada to continue to use the

allegedly infringing part of the Work; or

- (b) modify or replace the Work to avoid intellectual property infringement, while ensuring that the Work continues to meet all the requirements of the Contract; or
- (c) take back the Work and refund any part of the Contract Price that Elections Canada has already paid.

If the Contractor determines that none of these alternatives can reasonably be achieved, or if the Contractor fails to take any of these steps within a reasonable amount of time, Elections Canada may choose either to require the Contractor to do (c), or to take whatever steps are necessary to acquire the rights to use the allegedly infringing part(s) of the Work itself, in which case the Contractor must reimburse Elections Canada for all the costs it incurs to do so.

Article 18 Excusable Delay

18.01.01 A delay in the performance by the Contractor of any obligation under the Contract that is caused by an event that

- (a) is beyond the reasonable control of the Contractor,
- (b) could not reasonably have been foreseen,
- (c) could not reasonably have been prevented by means reasonably available to the Contractor, and
- (d) occurred without the fault or neglect of the Contractor, will be considered an “Excusable Delay” if the Contractor
 - i. advises the Contracting Authority of the occurrence of the delay or of the likelihood of the delay as soon as the Contractor becomes aware of it,
 - ii. provides for approval to the Contracting Authority within 15 working days of Subparagraph i. a clear work around plan explaining in detail the steps that the Contractor proposes to take in order to minimize the impact of the event causing the delay.

18.01.02 Any delivery date or other date that is directly affected by an Excusable Delay will be postponed for a reasonable time that will not exceed the duration of the Excusable Delay.

18.01.03 However, if an Excusable Delay has continued for 30 days or more, the Contracting Authority may, by giving notice in writing to the Contractor, terminate the Contract. In such a case, the Parties agree that neither will make any claim against the other for damages, costs, expected profits or any other loss arising out of the termination or the event that contributed to the Excusable Delay. The Contractor agrees to repay immediately to Elections Canada the portion of any advance payment that is unliquidated at the date of the termination.

- 18.01.04 Unless Elections Canada has caused the delay by failing to meet an obligation under the Contract, Elections Canada will not be responsible for any costs incurred by the Contractor or any of its subcontractors or agents as a result of an Excusable Delay.
- 18.01.05 If the Contract is terminated under this Section, the Contracting Authority may require the Contractor to deliver to Elections Canada, in the manner and to the extent directed by the Contracting Authority, any completed parts of the Work not delivered and accepted before the termination and anything that the Contractor has acquired or produced specifically to perform the Contract. Elections Canada will pay the Contractor:
- (a) the value, of all completed parts of the Work delivered to and accepted by Elections Canada, based on the Contract Price, including the proportionate part of the Contractor's profit or fee included in the Contract Price; and
 - (b) the Cost to the Contractor that Elections Canada considers reasonable in respect of anything else delivered to and accepted by Elections Canada.
 - (c) The total amount paid by Elections Canada under the Contract to the date of termination and any amounts payable under this Subsection must not exceed the Contract Price.

Article 19 Suspension of the Work

- 19.01.01 The Contracting Authority may at any time, by written notice, order the Contractor to suspend or stop the Work or part of the Work under the Contract for a period of up to 180 days. The Contractor must immediately comply with any such order in a way that minimizes the cost of doing so. While such an order is in effect, the Contractor must not remove any part of the Work from any premises without first obtaining the written consent of the Contracting Authority. Within these 180 days, the Contracting Authority must either cancel the order or terminate the Contract, in whole or in part, under Article 20 (Default by the Contractor) or Article 21 (Termination for Convenience).
- 19.01.02 The Contracting Authority may, whether in the notice of the order or during the 180 days referred to in Subsection 19.01.01, request that the Contractor provide information regarding the status of the Work or outstanding invoices. The Contractor shall respond within the timeline provided in the request.
- 19.01.03 When an order is made under Subsection 19.01.01, unless the Contracting Authority terminates the Contract by reason of default by the Contractor or the Contractor abandons the Contract, the Contractor will be entitled to be paid its additional costs incurred as a result of the suspension plus a fair and reasonable profit.
- 19.01.04 When an order made under Subsection 19.01.01 is cancelled, the Contractor must resume work in accordance with the Contract as soon as practicable. If the suspension has affected the Contractor's ability to meet any delivery date under the Contract, the date for

performing the part of the Work affected by the suspension will be extended for a period equal to the period of suspension plus a period, if any, that in the opinion of the Contracting Authority, following consultation with the Contractor, is necessary for the Contractor to resume the Work. Any equitable adjustments will be made as necessary to any affected conditions of the Contract.

Article 20 Default by the Contractor

- 20.01.01 If the Contractor is in default in carrying out any of its obligations under the Contract, the Contracting Authority may, by giving written notice to the Contractor, terminate for default the Contract or part of the Contract. The termination will take effect immediately or at the expiration of a cure period specified in the notice, if the Contractor has not cured the default to the satisfaction of the Contracting Authority within that cure period.
- 20.01.02 If the Contractor becomes bankrupt or insolvent, makes an assignment for the benefit of creditors, or takes the benefit of any statute relating to bankrupt or insolvent debtors, or if a receiver is appointed under a debt instrument or a receiving order is made against the Contractor, or an order is made or a resolution passed for the winding down of the Contractor, the Contracting Authority may, to the extent permitted by the laws of Canada, by giving written notice to the Contractor, immediately terminate for default the Contract or part of the Contract.
- 20.01.03 If Elections Canada gives notice under Subsection 20.01.01 or 20.01.02, the Contractor will have no claim for further payment except as provided in this Section. The Contractor will be liable to Elections Canada for all losses and damages suffered by Elections Canada because of the default or occurrence upon which the notice was based, including any increase in the cost incurred by Elections Canada in procuring the Work from another source. The Contractor agrees to repay immediately to Elections Canada the portion of any advance payment that is unliquidated at the date of the termination.
- 20.01.04 Upon termination of the Contract under this Section, the Contracting Authority may require the Contractor to deliver to Elections Canada, in the manner and to the extent directed by the Contracting Authority, any completed parts of the Work, not delivered and accepted before the termination and anything the Contractor has acquired or produced specifically to perform the Contract. In such a case, subject to the deduction of any claim that Elections Canada may have against the Contractor arising under the Contract or out of the termination, Elections Canada will pay or credit to the Contractor:
- (a) the value, of all completed parts of the Work delivered to and accepted by Elections Canada, based on the Contract Price, including the proportionate part of the Contractor's profit or fee included in the Contract Price; and
 - (b) the cost to the Contractor that Elections Canada considers reasonable in respect of anything else delivered to and accepted by Elections Canada.
- 20.01.05 The total amount paid by Elections Canada under the Contract to the date of the

termination and any amount payable under this Subsection must not exceed the Contract Price.

- 20.01.06 Title to everything for which payment is made to the Contractor will, once payment is made, pass to Elections Canada unless it already belongs to Elections Canada under any other provision of the Contract.
- 20.01.07 If the Contract is terminated for default under Subsection 20.01.01, but it is later determined that grounds did not exist for a termination for default, the notice will be considered a notice of termination for convenience issued under Subsection 21.01.01

Article 21 Termination for Convenience

- 21.01.01 At any time before the completion of the Work, the Contracting Authority may, by giving notice in writing to the Contractor, terminate for convenience the Contract or part of the Contract. Once such a notice of termination for convenience is given, the Contractor must comply with the requirements of the termination notice. If the Contract is terminated in part only, the Contractor must proceed to complete any part of the Work that is not affected by the termination notice. The termination will take effect immediately or, as the case may be, at the time specified in the termination notice.
- 21.01.02 If a termination notice is given pursuant to Subsection 21.01.01, the Contractor will be entitled to be paid, for costs that have been reasonably and properly incurred to perform the Contract to the extent that the Contractor has not already been paid or reimbursed by Elections Canada. The Contractor will be paid:
- (a) on the basis of the Contract Price, for all completed Work that is inspected and accepted in accordance with the Contract, whether completed before, or after the termination in accordance with the instructions contained in the termination notice;
 - (b) the Cost to the Contractor plus a fair and reasonable profit for all work terminated by the termination notice before completion; and
 - (c) all costs incidental to the termination of the Work incurred by the Contractor but not including the cost of severance payments or damages to employees whose services are no longer required, except wages that the Contractor is obligated by statute to pay.

Elections Canada may reduce the payment in respect of any part of the Work, if upon inspection; it does not meet the requirements of the Contract.

- 21.01.03 The total of the amounts, to which the Contractor is entitled to be paid under this Section, together with any amounts paid, due or becoming due to the Contractor must not exceed the Contract Price. The Contractor will have no claim for damages, compensation, loss of profit, allowance arising out of any termination notice given by Elections Canada under this Section except to the extent that this Section expressly provides. The Contractor agrees to

repay immediately to Elections Canada the portion of any advance payment that is unliquidated at the date of the termination.

Article 22 Assignment

- 22.01.01 The Contractor must not assign the Contract without first obtaining the written consent of the Contracting Authority. Any assignment made without that consent is void and will have no effect. The assignment will be effective upon execution of an assignment agreement signed by the Parties and the assignee.
- 22.01.02 Assignment of the Contract does not relieve the Contractor from any obligation under the Contract and it does not impose any liability upon Elections Canada.

Article 23 Right of Set-Off

Without restricting any right of set-off given by law, Elections Canada may set-off against any amount payable to the Contractor under the Contract, any amount payable to Elections Canada by the Contractor under the Contract or under any other current contract. Elections Canada may, when making a payment pursuant to the Contract, deduct from the amount payable to the Contractor any such amount payable to Elections Canada by the Contractor which, by virtue of the right of set-off, may be retained by Elections Canada.

Article 24 Amendments and Waivers

Section 24.01 Amendment

- 24.01.01 To be effective, any amendment to the Contract must be done in writing by the Contracting Authority and the authorized representative of the Contractor.
- 24.01.02 While the Contractor may discuss any proposed modifications to the Work with other representatives of Elections Canada, Elections Canada will not be responsible for the cost of any modification unless it has been incorporated into the Contract in accordance with Subsection 24.01.01.

Section 24.02 Waiver

- 24.02.01 A waiver will only be valid, binding or affect the rights of the Parties if it is made in writing by, in the case of a waiver by Elections Canada, the Contracting Authority and, in the case of a waiver by the Contractor, the authorized representative of the Contractor.
- 24.02.02 The waiver by a Party of a breach of any condition of the Contract will not be treated or interpreted as a waiver of any subsequent breach and therefore will not prevent it from enforcing that term or condition in the case of a subsequent breach.

Article 25 Codes

Section 25.01 Conflict of Interest and Values and Ethics Codes for the Public Sector

The Contractor acknowledges that individuals who are subject to the provisions of the *Conflict of Interest Act*, 2006, c. 9, s. 2, the Conflict of Interest Code for Members of the House of Commons, the Values and Ethics Code for the Public Sector or all other codes of values and ethics applicable within specific organizations cannot derive any direct benefit resulting from the Contract.

Section 25.02 Code of Conduct for Procurement

The Contractor certifies that it has read the Code of Conduct for Procurement (<http://www.tpsgc-pwgsc.gc.ca>) and agrees to be bound by its terms.

Article 26 No Bribe or Conflict

Section 26.01 No Bribe

The Contractor declares that no bribe, gift, benefit, or other inducement has been or will be paid, given, promised or offered directly or indirectly to any official or employee of Elections Canada or to a member of the family of such a person, with a view to influencing the entry into the Contract or the administration of the Contract.

Section 26.02 No Conflict of Interest

- 26.02.01 The Contractor must not influence, seek to influence or otherwise take part in a decision of Elections Canada knowing that the decision might further its private interest. The Contractor must have no financial interest in the business of a third party that causes or would appear to cause a conflict of interest in connection with the performance of its obligations under the Contract. If such a financial interest is acquired during the period of the Contract, the Contractor must immediately declare it to the Contracting Authority.
- 26.02.02 The Contractor warrants that, to the best of its knowledge after making diligent inquiry, no conflict exists. In the event the Contractor becomes aware of any matter that causes or is likely to cause a conflict in relation to the Contractor's performance under the Contract, the Contractor must immediately disclose such matter to the Contracting Authority in writing.
- 26.02.03 If the Contracting Authority is of the opinion that a conflict exists as a result of the Contractor's disclosure or as a result of any other information brought to the Contracting Authority's attention, the Contracting Authority may require the Contractor to take steps to resolve or otherwise deal with the conflict or, at its entire discretion, terminate the Contract for default. Conflict means any matter, circumstance, interest, or activity affecting the Contractor, its personnel or subcontractors, which may or may appear to impair the ability of the Contractor to perform the Work diligently and independently.

Article 27 Contingency Fees

27.01.01 The Contractor certifies that it has not, directly or indirectly, paid or agreed to pay and agrees that it will not, directly or indirectly, pay a contingency fee for the solicitation, negotiation or obtaining of the Contract to any person, other than an employee of the Contractor acting in the normal course of the employee's duties.

27.01.02 In this Section

(a) "contingency fee" means any payment or other compensation that depends or is calculated based on a degree of success in soliciting, negotiating or obtaining the Contract; and

(b) "person" includes any individual who is required to file a return with the registrar pursuant to Section 5 of the *Lobbying Act*, 1985, c. 44 (4th Supplement).

Article 28 International Sanctions

28.01.01 Persons in Canada, and Canadians outside of Canada, are bound by economic sanctions imposed by Canada. As a result, Elections Canada cannot accept delivery of goods or services that originate, either directly or indirectly, from the countries or persons subject to economic sanctions.

28.01.02 The Contractor must not supply to Elections Canada any goods or services which are subject to economic sanctions.

28.01.03 The Contractor must comply with changes to the regulations imposed during the period of the Contract. The Contractor must immediately advise Elections Canada if it is unable to perform the Work as a result of the imposition of economic sanctions against a country or person or the addition of a good or service to the list of sanctioned goods or services. If the Parties cannot agree on a work around plan, the Contract will be terminated for the convenience of Elections Canada in accordance with Article 21 (Termination for Convenience).

Article 29 Notice

Any notice under the Contract must be in writing and may be delivered by hand, courier, mail, facsimile or other electronic method that provides a paper record of the text of the notice. It must be sent to the Party for whom it is intended at the address stated in the Contract or to such other address, from time to time designated in writing. Any notice will be effective on the day it is received at that address. Any notice to Elections Canada must be delivered to the Contracting Authority.

Article 30 Survival

All the Parties' obligations of confidentiality, representations and warranties set out in the Contract as well as the provisions, which by the nature of the rights or obligations might reasonably be expected to survive, will survive the expiry or termination of the Contract.

Article 31 Governing Law

Section 31.01 Compliance with Applicable Laws

- 31.01.01 The Contractor must comply with all laws applicable to the performance of the Contract. The Contractor must provide evidence of compliance with such laws to Canada at such times as Elections Canada may reasonably request.
- 31.01.02 The Contractor must obtain and maintain at its own cost all permits, licenses, regulatory approvals and certificates required to perform the Work. If requested by the Contracting Authority, the Contractor must provide a copy of any required permit, license, regulatory approvals or certificate to Elections Canada.

Article 32 Successor and Assigns

The Contract is binding upon and enures to the benefit of Elections Canada and its successors and assigns and the Contractor and its successors and permitted assigns.

Annex D

Invoicing Instructions (successful bidder only)

Invoicing Instructions

1. Payment will only be made on receipt of an original invoice duly supported by specific release documents and other documents called for under the Contract.
2. Original invoices must be submitted on the Contractor's own invoice form and must be prepared to show:
 - a) the date;
 - b) name of the Administrative Officer and address of the Consignee;
 - c) item/reference number, deliverable and/or description of the work;
 - d) contract serial number and financial code(s); and,
 - e) the amount invoiced (exclusive of the Goods and Services Tax (GST) or Harmonized Sales Tax (HST) as appropriate) and the amount of GST or HST, as appropriate shown separately
 - f) Client Reference Number (CRN)
 - g) Procurement Business Number (PBN)

T1204 Invoicing Instructions

1. Pursuant to paragraph 221 (1)(d) of the Income Tax Act, payments made by departments and agencies to contractors under applicable services contracts (including contracts involving a mix of goods and services) must be reported on a T1204, Government Service Contract Payments slip.
2. To enable departments and agencies to comply with this requirement, the Contractor shall provide the information listed below with its first invoice. Where the required information includes a Social Insurance Number (SIN), the information should be provided in a separate envelope marked "PROTECTED" and attached to the invoice:
 - a) the legal name of the business entity or sole proprietorship, as applicable, i.e. the legal name associated with the Business Number (BN) or SIN, as well as the address and the postal code;
 - b) the type of entity, i.e. corporation, partnership, sole proprietorship, or joint venture;
 - c) the BN if the entity is a corporation or partnership; the SIN if the entity is a sole proprietorship:
 - 2.1 if the entity is a partnership and does not have a BN, then the partner who has signed the contract must provide its SIN.
 - 2.2 if the entity is a joint venture, then the BN of all contractors comprising the joint venture that will receive payment (SIN for applicable contractor(s) without a BN), the Contractor or an authorized officer must sign the following certification:

"I certify that I have examined the information provided in (a), (b) and (c) above, and that it is correct and complete, and fully disclose the identification of this Contractor."