



REQUEST FOR TENDER

**CONSTRUCTION AND INSTALLATION OF A FIELD LAB AT
ENVIRONMENT CANADA'S SAMPLE SITE SITUATED AT WOLF E
ISLAND, ONTARIO**
5365 Highway 96,
Wolfe Island, Ontario (K0H 2Y0).

Solicitation number: KW405-14-5720

Closing date : September 30, 2014
Closing time: 02h00 pm (Eastern Daylight Time)

Direct All Enquiries to:

Contracting Authority:

Marie-Christine Blais, Procurement Officer
Environnement Canada
Procurement and Contracting Division
Finance Branch
105 McGill 5th floor
Montreal (Quebec) H2Y 2E7
Phone : (514) 496-1929
Fax : (514) 283-4439
Email : marie-christine.blais@ec.gc.ca

or Anthony, DeFlavis, Procurement Officer

Phone : (514) 283-5958
Fax : (514) 283-4439
Email : anthony.deflavis@ec.gc.ca

Submit Tenders to:

Environment Canada
Procurement and Contracting Division
Finance Branch
800 rue de la Guichetière Ouest
Bureau 7810
Montreal (Quebec) H5A 1L9

IMPORTANT NOTE TO BIDDERS:

- *Proposals must be submitted by the date, time and address indicated above*
- *Bids submitted by fax or email **WILL NOT BE ACCEPTED.***
- *All enquiries must be submitted in writing to the Contracting Authority no later than five (5) business days before the bid closing date. Enquiries received after that time may not be answered before the bid closing date.*

Failure to comply with the requirements contained herein may lead to tender disqualification.

TABLE OF CONTENTS

1 SECTION 1 INSTRUCTIONS TO TENDERS R0001T (2004-12-10) AND R0002T (2000-05-12)	5
IT01 TENDER DOCUMENTS.....	5
1) The tender documents.....	5
2) Tenderer Declaration.....	5
3) Mandatory Requirements	5
4) Site Visit Information (MANDATORY).....	5
IT02 COMPLETION OF TENDER (MANDATORY).....	6
IT03 SUBMISSION OF TENDER.....	6
IT04 REVISION OF TENDER.....	7
IT05 SIGNING PROCEDURES	7
IT06 TENDER INQUIRIES.....	7
IT07 TENDER RESULTS	8
IT08 EVALUATION AND ACCEPTANCE OF TENDER (MANDATORY).....	8
IT09 NEGOTIATIONS	8
IT10 TENDER VALIDITY PERIOD.....	9
IT11 LISTING OF SUBCONTRACTORS AND SUPPLIERS.....	9
IT12 COMPLIANCE WITH APPLICABLE LAWS	9
IT13 TAXES.....	9
IT14 APPROVAL OF ALTERNATIVE MATERIALS	10
IT15 PERFORMANCE EVALUATION	10
IT16 LANGUAGE OF THE TENDER AND CONTRACT DOCUMENTS.....	10
IT17 INSURANCE: REPRESENTATION AND WARRANTY	10
IT18 TENDER SECURITY REQUIREMENTS	10
IT19 CONTRACT SECURITY REQUIREMENTS.....	11
IT20 CAPITAL DEVELOPMENT AND RE-DEVELOPMENT CHARGES	11
IT21 BID DEPOSITORY.....	11
IT22 CONTRACTOR PERFORMANCE EVALUATION REPORT (CPER).....	12
IT23 DRAWINGS AND SPECIFICATIONS.....	12
2 SECTION 2 PROJECT BRIEF	13
3 SECTION 3 TENDER ACCEPTANCE FORM (TA)	16
TA01 PROJECT IDENTIFICATION AND SECURITY.....	16
TA02 BUSINESS NAME AND ADDRESS OF TENDERER	16
TA03 OFFER.....	16
TA04 ADDENDA (MANDATORY).....	17
TA05 APPENDICES.....	17
TA06 ACCEPTANCE AND CONTRACT	17
TA07 CONSTRUCTION TIME	17
TA08 UNIT PRICE TABLE.....	18
TA09 TENDER SECURITY.....	18
TA10 CONTRACT SECURITY	18
TA11 EXECUTION OF PROPOSAL	19
Appendix 1 Completed Projects.....	20
Appendix 2 Listing of Subcontractors and Suppliers	21
Appendix 3 Breakdown of Major Item Prices.....	22
Appendix 4 UNIT PRICE TABLE (Not Applicable).....	23
4 SECTION 4 CONTRACT DOCUMENTS – ARTICLES OF AGREEMENT “A” R0200C (2004-12-10)	24
A1 CONTRACT DOCUMENTS.....	24
A2 APPROPRIATE LAW	24
A3 COMPLETION AND DESCRIPTION OF WORK.....	25
A4 CONTRACT AMOUNT.....	25
A5 UNIT PRICE TABLE	25
A6 DEPARTMENTAL REPRESENTATIVE.....	25
A7 CONTRACTING AUTHORITY.....	25
5 SECTION 5 CONTRACT DOCUMENTS – STATEMENT OF WORK	29

TABLE OF CONTENTS

APPENDIX "A" STATEMENT OF WORK (SOW).....	ERREUR ! SIGNET NON DEFINI.
6 SECTION 6 CONTRACT DOCUMENTS – TERMS OF PAYMENT.....	30
APPENDIX "B" TERMS OF PAYMENTS (TP)	ERREUR ! SIGNET NON DEFINI.
7 SECTION 7 CONTRACT DOCUMENTS GENERAL CONDITIONS (GC) R0202D (2004-05-14)	31
APPENDIX "C" GENERAL CONDITION (GC)	31
GC1 GENERAL PROVISIONS	31
GC1.1 INTERPRETATION.....	31
GC1.2 CONTRACT DOCUMENTS.....	33
GC1.3 STATUS OF THE CONTRACTOR	34
GC1.5 INDEMNIFICATION BY CONTRACTOR.....	35
GC1.6 INDEMNIFICATION BY CANADA.....	35
GC1.7 LAWS, PERMITS AND TAXES	35
GC1.8 WORKERS' COMPENSATION	36
GC1.9 NATIONAL SECURITY.....	36
GC1.10 UNSUITABLE WORKERS	36
GC1.11 PUBLIC CEREMONIES AND SIGNS.....	36
GC1.12 CONFLICT OF INTEREST	37
GC1.13 MEMBERS OF HOUSE OF COMMONS NOT TO BENEFIT	37
GC1.14 AGREEMENTS AND AMENDMENTS.....	37
GC1.15 SUCCESSION.....	37
GC1.16 ASSIGNMENT.....	37
GC1.17 NO BRIBE.....	37
GC1.18 CERTIFICATION - CONTINGENCY FEES	37
GC2 ADMINISTRATION OF THE CONTRACT	38
GC2.1 DEPARTMENTAL REPRESENTATIVE'S AUTHORITY.....	38
GC2.2 INTERPRETATION OF CONTRACT.....	38
GC2.3 NOTICES	38
GC2.4 SITE MEETINGS.....	39
GC2.5 REVIEW AND INSPECTION OF WORK	39
GC2.6 SUPERINTENDENT	40
GC2.7 NON-DISCRIMINATION IN HIRING AND EMPLOYMENT OF LABOUR	40
GC2.8 ACCOUNTS AND AUDITS	41
GC3 EXECUTION AND CONTROL OF THE WORK	41
GC3.1 PROGRESS SCHEDULE	41
GC3.2 ERRORS AND OMISSIONS.....	42
GC3.3 CONSTRUCTION SAFETY	42
GC3.4 EXECUTION OF THE WORK.....	43
GC3.5 MATERIAL	43
GC3.6 SUBCONTRACTING	44
GC3.7 CONSTRUCTION BY OTHER CONTRACTORS OR WORKERS	44
GC3.8 LABOUR AND FAIR WAGES.....	45
GC3.9 MATERIAL, PLANT AND REAL PROPERTY BECOME PROPERTY OF CANADA.....	45
GC3.10 DEFECTIVE WORK.....	46
GC3.11 CLEANUP OF SITE	46
GC3.12 WARRANTY AND RECTIFICATION OF DEFECTS IN WORK	46
GC4 PROTECTIVE MEASURES.....	47
GC4.1 PROTECTION OF WORK AND PROPERTY.....	47
GC4.2 PRECAUTIONS AGAINST DAMAGE, INFRINGEMENT OF RIGHTS, FIRE AND OTHER HAZARDS	47
GC4.3 MATERIAL, PLANT AND REAL PROPERTY SUPPLIED BY CANADA	47
GC4.4 CONTAMINATED SITE CONDITIONS.....	48
GC5.1 INTERPRETATION.....	49
IN THESE TERMS OF PAYMENT.....	49
GC5.2 AMOUNT PAYABLE.....	49
GC5.3 INCREASED OR DECREASED COSTS	49
GC5.4 PROGRESS PAYMENT	50
GC5.5 SUBSTANTIAL PERFORMANCE OF THE WORK	51

TABLE OF CONTENTS

GC5.6	FINAL COMPLETION.....	52
GC5.7	PAYMENT NOT BINDING ON CANADA	52
GC5.8	CLAIMS AND OBLIGATIONS	52
GC5.10	ASSESSMENTS AND DAMAGES FOR LATE COMPLETION	54
GC5.11	DELAY IN MAKING PAYMENT.....	54
GC5.13	RETURN OF SECURITY DEPOSIT	55
GC6	DELAYS AND CHANGES IN THE WORK	55
GC6.1	CHANGES IN THE WORK	55
GC6.2	CHANGES IN SUBSURFACE CONDITIONS	55
GC6.3	HUMAN REMAINS, ARCHAEOLOGICAL REMAINS AND ITEMS OF HISTORICAL OR SCIENTIFIC INTEREST.....	56
GC6.4	DETERMINATION OF PRICE	57
GC6.5	DELAYS AND EXTENSION OF TIME.....	59
GC7	DEFAULT, SUSPENSION OR TERMINATION OF CONTRACT	60
GC7.1	TAKING THE WORK OUT OF THE CONTRACTOR'S HANDS	60
GC7.2	SUSPENSION OF WORK	61
GC7.3	TERMINATION OF CONTRACT	61
GC7.4	SECURITY DEPOSIT - FORFEITURE OR RETURN.....	61
GC8	DISPUTE RESOLUTION	62
GC8.1	INTERPRETATION	62
GC8.2	CONSULTATION AND CO-OPERATION	62
GC8.3	AUTHORITY OF DEPARTMENTAL REPRESENTATIVE	62
GC8.4	NEGOTIATION	63
GC8.5	MEDIATION	63
GC8.7	DISPUTES NOT SUBJECT TO ARBITRATION	64
GC8.8	CONFIDENTIALITY	65
GC8.9	SETTLEMENT	65
	DISPUTE RESOLUTION - SCHEDULE "A"	65
	RULES FOR MEDIATION OF CONSTRUCTION CONTRACT DISPUTES	65
	DISPUTE RESOLUTION - SCHEDULE B.....	68
	RULES FOR ARBITRATION OF CONSTRUCTION CONTRACT DISPUTES	68
GC9.1	OBLIGATION TO PROVIDE CONTRACT SECURITY	73
GC9.2	TYPES AND AMOUNTS OF CONTRACT SECURITY	73
GC10	INSURANCE.....	75
GC10.1	INSURANCE	75
GC10.3	PAYMENT OF DEDUCTIBLE.....	76
GC10.4	PERIOD OF INSURANCE	76
GC10.5	COMMERCIAL GENERAL LIABILITY.....	76
GC10.6	BUILDER'S RISK - INSTALLATION FLOATER - ALL RISKS.....	77
GC10.7	INSURANCE PROCEEDS.....	78
GC11	LABOUR CONDITIONS - R0203D (2004-05-14).....	81
GC11.1	Interpretation	81
GC11.2	General Fair Wage Clause	81
GC11.3	Hours of Work.....	81
GC11.4	Labour Conditions to be Posted.....	82
GC11.5	Contractor Records Kept Open for Inspection	82
GC11.6	Departmental Requirements before Payment made to Contractor	82
GC11.7	Authority to pay Wages in the Event of Default by the Contractor	82
GC11.8	Conditions of Subcontracting	82
GC11.9	Non-discrimination in Hiring and Employment of Labour	83
GC11.10	Schedule of Fair Wages	83
8	SECTION 8 SUPPLEMENTARY CONDITIONS.....	84
	APPENDIX "D" SUPPLEMENTARY CONDITIONS.....	84
SC1	EMPLOYMENT EQUITY	84
SC2	WORK FORCE REDUCTION PROGRAM.....	84
SC3	INTELLECTUAL PROPERTY - CONTRACTOR OWNS IP	85
SC4	INTERNATIONAL SANCTIONS.....	88
9	SECTION 9 LIST OF SPECIFICATIONS AND DRAWINGS	89

**1 SECTION 1
INSTRUCTIONS TO TENDERERS (IT)**

1 SECTION 1 INSTRUCTIONS TO TENDERS R0001T (2004-12-10) and R0002T (2000-05-12)

IT01 TENDER DOCUMENTS

1) The tender documents

are listed below:

- (a) Front Page – REQUEST FOR TENDER;
- (b) Mandatory Site Visit Information
- (c) Instructions to Tenderers (IT);
- (d) Tender Acceptance Form and any Appendices attached thereto;
- (e) Contract Documents - Articles of Agreement
- (f) Contract Documents - General Conditions (GC) of the Contract
 - GC1 General Provisions
 - GC2 Administration of the Contract
 - GC3 Execution and Control of the Work
 - GC4 Protective Measures
 - GC5 Terms of Payment
 - GC6 Delays and Changes in the Work
 - GC7 Default, Suspension or Termination of Contract
 - GC8 Dispute Resolution
 - GC9 Contract Security
 - GC10 Insurance
 - GC11 Labour Conditions – Fair Wages and Hours of Labour
- (g) Contract Documents - Supplementary Conditions (SC) of the Contract
 - SC1 International Sanctions
 - SC2 Employment Equity
 - SC3 Work Force Reduction Program
 - SC4 Intellectual Property
- (h) Plans, Specifications and Drawings
- (i) Work-Site, Health and Safety Working Practices & Building Guidelines; and
- (j) Any addenda issued before the date set for tender closing.

2) Tenderer Declaration

The tender documents identified in paragraphs 1.(a) to 1.(j) inclusive by title, number and date are hereby incorporated by reference into the tender documents and form part of the tender and any resultant contract. Submission of a tender constitutes acknowledgment that the Tenderer has read and agreed to be bound by these documents and the other documents listed in subsection IT01 (1) above.

3) Mandatory Requirements

Throughout Sections 1, 2 and 3 of this document, certain requirements are identified as mandatory. A mandatory requirement is a minimum standard that a submission must meet in order to be considered for further evaluation. Failure to meet any of the mandatory requirements will render the submission liable for disqualification.

Mandatory requirements are marked “**MANDATORY**” and are identified in the following sections of this document:

- Section 1 – Instructions to Tenderers
- Section 2 – Project Brief, and
- Section 3 – Tender and Acceptance Form.

4) Site Visit Information (MANDATORY)

It is mandatory that the Bidder or a representative of the Bidder visit the work site. Arrangements have been made for the site visit to be held at EC's sample site on Wolfe Island, **on Wednesday September 17,**

**1 SECTION 1
INSTRUCTIONS TO TENDERERS (IT)**

2014. The site visit will begin at **1:30 p.m. (Eastern Daylight Time)**. Bidders will be met at the entrance situated at 5365 Highway 96, Wolfe Island (On) K0H 2Y0.

Bidders must communicate with the Contracting Authority no later than September 16, 2014 to confirm attendance and provide the name(s) of the person(s) who will attend. Bidders will be required to sign an attendance sheet. Bidders should confirm in their bid that they have attended the site visit. Bidders who do not attend the mandatory site visit or do not send a representative will not be given an alternative appointment and their bid will be declared non-responsive. Any clarifications or changes to the bid solicitation resulting from the site visit will be included as an amendment to the bid solicitation

Failure to attend the "Site Visit" will result in bidder's disqualification.

IT02 COMPLETION OF TENDER (MANDATORY)

- 1) The tender shall be submitted based on the tender documents listed above, on the Tender Form provided through the Government Electronic Tendering Service (GETS) or by the contracting officer on a clear and legible reproduced copy of said Tender Form; the reproduced copy must be identical in every respect to the Tender Form provided through GETS, accompanied by the tender security required, all tender documents being dully completed in all respects and signed as instructed herein. Substitute and/or facsimile copies will not be accepted.
- 2) Any alteration to the pre-printed or pre-typed sections of the Tender Form may render the tender liable to disqualification. Alterations, corrections, changes or erasures entered on the Tender Form shall be initialed by the Tenderer or the person signing the tender. Alterations, corrections, changes or erasures that are not initialed shall be deemed void and without effect.

IT03 SUBMISSION OF TENDER

- 1) The Tender, duly completed, shall be enclosed in a sealed envelope, and shall be addressed and delivered to the office indicated on the cover page of this document, on or before the date and time set for tender closing.
- 2) Prior to submitting the tender, the Tenderer shall ensure that the following information is clearly printed or typed in the appropriate spaces on the outermost face of the tender return envelope:
 - (a) Tender ID
 - (b) Project Description/Location
 - (c) Name of Tenderer; and
 - (d) Closing Time/Date

Failure to comply with the requirements outlined at 1) and 2) will result in tender disqualification.

- 3) Unacceptable Tenders
 - (a) Tender not submitted on the accompanying Tender and Acceptance Form will not be considered.
 - (b) Telegraphic and facsimile tenders will not be accepted.
 - (c) Tenders received after the Tender Closing Time will not be considered.
 - (d) Incomplete tenders may be rejected.
- 4) Timely and correct delivery of tenders to the "Tender Receiving Unit" as well as all the risks and consequences associated with an incorrect delivery are the sole responsibility of the Tenderer.
- 5) Bids received on or before the stipulated bid solicitation closing date and time will become the property of Canada and will not be returned. All bids will be treated as CONFIDENTIAL, subject to the provisions of the Access to Information and Privacy Act.
- 6) Bids received after the date of closing shall be returned unopened to the Tenderer

1 SECTION 1
INSTRUCTIONS TO TENDERERS (IT)

IT04 REVISION OF TENDER

- 1) A tender may be revised by letter or facsimile provided the revision is received on or before the closing date and time of tenders. The facsimile number for receipt of revisions is indicated on the cover page of this document.
- 2) The letter or facsimile shall
 - (a) be on the Tenderer's letterhead or bear a signature that identifies the Tenderer;
 - (b) for the lump sum portion of a tender, clearly identify the amount of the current revision. The total aggregate sum of all revisions submitted, including the current revision, shall be shown separately; and
 - (c) for the Unit Price portion of a tender, clearly identify the change(s) in the price(s) per Unit and the specific item(s) to which each change applies.
- 3) Any alteration to the preprinted or pre-typed sections of the Tender Form, or any condition or qualification placed upon the tender shall be direct cause for disqualification. Alterations, corrections, changes or erasures made to statements or figures entered on the Tender Form by the Tenderer shall be initialed by the person or persons signing the tender. Initials shall be original(s). Alterations, corrections, changes or erasures that are not initialed shall be deemed void and without effect.

IT05 SIGNING PROCEDURES

- 1) The signature(s) of the authorized signatory(ies) shall be affixed to the front page of the Invitation to Tender and the name(s) and the title(s) typed or printed in the space provided.
- 2) The tender shall be signed in accordance with the following requirements:
 - (a) Corporation - The signatures of the authorized signatories shall be affixed and their names and titles typed or printed in the space provided and the corporate seal may be affixed. If the corporate seal is not affixed to the tender, the signatures shall be witnessed and proof of signing authority shall be provided. In the Province of Quebec signatures must be witnessed and, except when a director signs the tender, proof of signing authority shall be provided whether or not a corporate seal is affixed.
 - (b) Partnership - The signatures of the partners shall be affixed and their names typed or printed in the space provided. The signatures shall be witnessed, and if not all of the partners sign or if the signatory is not a partner then a certified true copy of the agreement signed by all partners authorizing such person or persons to execute the document on their behalf shall accompany the tender. An adhesive coloured seal shall be affixed next to each signature except in the Province of Quebec.
 - (c) Sole Proprietorship - The signature of the sole proprietor shall be affixed and the name typed or printed in the space provided. The signature shall be witnessed. In the event that the signatory is not the sole proprietor then a certified true copy of the agreement signed by the sole proprietor authorizing such person or persons to execute the document shall accompany the tender. An adhesive coloured seal shall be affixed next to the signature except in the Province of Quebec.
 - (d) Joint Venture - The signatures of the authorized signatories of each member of the joint venture shall be affixed and their names and titles typed or printed in the space provided. Each of the participating signatories shall sign the document in the manner applicable to their particular business arrangement.

IT06 TENDER INQUIRIES

- 1) Enquiries suggesting alternative materials must be addressed to Contracting Authority named on the front page of this Request for Tender, for approval, providing full technical data is received, in writing, at least five (5) calendar days prior to the tender closing date indicated on the cover of this document.
- 2) All other enquiries regarding the tender must be submitted in writing to the Contracting Authority named on

1 SECTION 1
INSTRUCTIONS TO TENDERERS (IT)

the front page of the Request for Tender as early as possible within the tendering period and no later than five (5) calendar days prior to the date set for tender closing to allow sufficient time to provide a response.

- 3) Answers to all enquiries shall be provided simultaneously to all Tenderers having received Tender Documents without revealing the source of enquiries.

IT07 TENDER RESULTS

- 1) Following contract award, Tenderers will receive written notification of the tender results.

IT08 EVALUATION AND ACCEPTANCE OF TENDER (MANDATORY)

- 1) Canada may accept any tender, whether it is the lowest or not, or may reject any or all tenders.
- 2) Canada may reject a tender if any of the following circumstances are present:
- (a) the Tenderer or any employee or subcontractor included as part of the tender, has been convicted under sections 121, 124 or 418 of the Criminal Code.
 - (b) with respect to current or prior transactions with Canada, Canada determines that the Tenderer's performance on other contracts is sufficiently poor to jeopardize the successful completion of the requirement being tendered on.
- 3) In assessing the Tenderer's performance on other contracts Canada may consider, but not be limited to, such matters as:
- (a) the quality of workmanship in performing the work,
 - (b) the timeliness of completion of the work,
 - (c) the overall management of the work and its effect on the level of effort demanded of the department and its representatives; and
 - (d) the completeness and effectiveness of the Contractor's safety program during the performance of the Work.
- 4) Canada may reject a tender based on an unfavorable assessment of:
- (a) the adequacy of the tendered price to permit the work to be carried out and, in the case of a tender providing unit prices or a combination of lump sum and unit prices, whether each such price reasonably reflects the cost of performing the part of the work to which that price applies;
 - (b) the Tenderer's ability to provide the necessary management structure, skilled personnel, experience and equipment to competently perform the work under the contract, and
 - (c) the Tenderer's performance on other contracts.
- 5) If Canada intends to reject a tender pursuant to a provision of paragraphs 1), 2), 3) and 4) herein, the Minister will so inform the Tenderer and provide the Tenderer ten (10) days' notice within which to make representations, prior to making a final decision on the tender rejection.

IT09 NEGOTIATIONS

- 1) In the event that the lowest compliant tender exceeds the amount of funding Canada has allocated for the construction phase of the work
- (a) by 15% or less, Canada, at its sole discretion, shall either
 - (i) cancel the tender call; or
 - (ii) obtain additional funding and, subject to the provisions of clause IT13 of Instructions to Tenderers, award the Contract to the Tenderer submitting the lowest compliant tender; or
 - (iii) revise the scope of work accordingly and negotiate, with the Tenderer submitting the lowest compliant tender, a corresponding reduction in its tendered price.
 - (b) by more than 15%, Canada, at its sole discretion, shall either
 - (i) cancel the tender call; or
 - (ii) obtain additional funding and, subject to the provisions of clause IT13 of Instructions to

1 SECTION 1
INSTRUCTIONS TO TENDERERS (IT)

- (iii) Tenderers, award the Contract to the Tenderer submitting the lowest compliant tender; or revise the scope of work accordingly and invite all those who submitted compliant tenders at the original tender call to re-tender the work.

IT10 TENDER VALIDITY PERIOD

- 1) The Tenderers agree that all quotations, prices and costs submitted with the tender, shall remain firm and valid for a period of **one hundred and twenty (120) calendar days** after the tender closing.

IT11 LISTING OF SUBCONTRACTORS AND SUPPLIERS

The Tenderer is required to submit as part of the tender, all information requested relative to subcontracting parts of the work, including the list with the names of Subcontractors and Suppliers for the part or parts of the Work listed. Failure to do so will result in the disqualification of its tender.

IT12 COMPLIANCE WITH APPLICABLE LAWS

- 1) By submission of a tender, the Tenderer certifies that the Tenderer has the legal capacity to enter into a contract and is in possession of all valid licences, permits, registrations, certificates, declarations, filings or other authorizations necessary to comply with all federal, provincial and municipal laws and regulations applicable to the submission of the tender and entry into any ensuing contract for the performance of the work.
- 2) For the purpose of validating the certification in paragraph 1) herein, a Tenderer shall, if requested, provide a copy of every valid licence, permit, registration, certificate, declaration, filing or other authorization listed in the request within the time limit(s) set out in the said request.

IT13 TAXES (2013-03-21)

- 1) Federal government departments and agencies are required to pay Applicable Taxes.
- 2) Applicable Taxes will be paid by Canada as provided in the Invoice Submission section. It is the sole responsibility of the Contractor to charge Applicable Taxes at the correct rate in accordance with applicable legislation. The Contractor agrees to remit to appropriate tax authorities any amounts of Applicable Taxes paid or due.
- 3) The Contractor is not entitled to use Canada's exemptions from any tax, such as provincial sales taxes, unless otherwise specified by law. The Contractor must pay applicable provincial sales tax, ancillary taxes, and any commodity tax, on taxable goods or services used or consumed in the performance of the Contract (in accordance with applicable legislation), including for material incorporated into real property.
- 4) In those cases where Applicable Taxes, customs duties, and excise taxes are included in the Contract Price, the Contract Price will be adjusted to reflect any increase, or decrease, of Applicable Taxes, customs duties, and excise taxes that will have occurred between bid submission and contract award. However, there will be no adjustment for any change to increase the Contract Price if public notice of the change was given before bid submission date in sufficient detail to have permitted the Contractor to calculate the effect of the change.
- 5) Tax Withholding of 15 Percent – Canada Revenue Agency
- Pursuant to the *Income Tax Act*, 1985, c. 1 (5th Supp.) and the *Income Tax Regulations*, Canada must withhold 15 percent of the amount to be paid to the Contractor in respect of services provided in Canada if the Contractor is not a resident of Canada, unless the Contractor obtains a valid waiver from the *Canada Revenue Agency*. The amount withheld will be held on account for the Contractor in respect to any tax liability which may be owed to Canada.

**1 SECTION 1
INSTRUCTIONS TO TENDERERS (IT)**

IT14 APPROVAL OF ALTERNATIVE MATERIALS

- 1) Unless otherwise specified elsewhere in the Contract, materiel supplied shall be new and conform to the latest issue of the applicable drawing, specification and/or part number that is in effect on the solicitation closing date.
- 2) When materials are specified by trade names or trademarks, or by manufacturers' or suppliers' names, the tender shall be based on the use of the named materials. During the tendering period, alternative materials may be considered provided full technical data is received in writing by Canada at least ten (10) calendar days prior to the tender closing date. Upon approval of the alternative materials by Departmental Representative, an addendum to the tender documents will be issued.

IT15 PERFORMANCE EVALUATION

- 1) Tenderers shall take note that the Performance of the Contractor during and upon completion of the work shall be evaluated by Canada. The evaluation will be based on the quality of workmanship; timeliness of completion of the work; project management, contract management and management of health and safety. Should the Contractor's performance be considered unsatisfactory, the Contractor's bidding privileges on future work may be suspended indefinitely.

IT16 LANGUAGE OF THE TENDER AND CONTRACT DOCUMENTS

- 1) Bid documents and supporting information may be submitted in either English or French. The contract documents to be signed by the successful Tenderer shall be in the same official language as the language of the tender documents submitted.

IT17 INSURANCE: REPRESENTATION AND WARRANTY

- 1) By submission of this tender, the Tenderer hereby declares that it has the appropriate liability insurance coverage and warrants that it shall maintain all required insurance policies in place and effect throughout the entire project, as required by GC 10 INSURANCE.

IT18 TENDER SECURITY REQUIREMENTS

- 1) When the total amount of the tender is equal to or greater than \$100,000.00, the Tenderer shall submit tender security in the form of a bid bond or a security deposit, in the following manner:
 - (a) if the tender amount is between \$100,000.00 and \$250,000.00 the tender security shall be equal to not less than 10% of the tender amount;
 - (b) if the tender amount is greater than \$250,000.00, the tender security shall be equal to not less than \$25,000.00 plus an amount equal to 5% of the tender amount that exceeds \$250,000.00.
- 2) A bid bond shall be in an approved form, properly completed with original signature(s) and issued by an approved company whose bonds are acceptable to Canada.
- 3) A security deposit shall be an original, properly completed, signed where required and be either
 - (a) a bill of exchange, bank draft or money order payable to the Receiver General for Canada, or
 - (b) bonds of, or unconditionally guaranteed as to principal and interest by the Government of Canada;or
- 4) A bill of exchange, bank draft or money order referred to in subparagraph 3)(a) herein shall be certified by or drawn on
 - (a) a corporation or institution that is a member of the Canadian Payments Association;
 - (b) a corporation that accepts deposits that are insured by the Canada Deposit Insurance Corporation or the "Régie de l'assurance-dépôts du Québec" to the maximum permitted by law;
 - (c) a corporation that accepts public deposits and repayment of the deposits is unconditionally guaranteed by Her Majesty in right of a province;

1 SECTION 1
INSTRUCTIONS TO TENDERERS (IT)

- (d) a corporation, association or federation incorporated or organized as a credit union or cooperative credit society that conforms to the requirements of a credit union which are more particularly described in paragraph 137 (6)(b) of the Income Tax Act, or
 - (e) Canada Post Corporation.
- 5) If a bill of exchange, bank draft or money order is drawn on an institution or corporation other than a chartered bank it must be accompanied by proof that the said institution or corporation meets at least one of the criteria described in paragraph 4) herein, either by letter or by a stamped certification on the bill of exchange.
- 6) For the purposes of this section a bill of exchange is an unconditional order in writing signed by the Tenderer and addressed to an approved financial institution, requiring the said institution to pay, on demand, at a fixed or determinable time a sum certain of money to, or to the order of, the Receiver General for Canada.
- 7) Letters of guarantee and irrevocable letters of credit are not acceptable as tender security.
- 8) Bonds referred to in subparagraph 3)(b) shall be provided on the basis of their market value current at the date of tender closing, and shall be
- (a) payable to bearer, or
 - (b) accompanied by a duly executed instrument of transfer of the bonds to the Receiver General for Canada in the form prescribed by the Domestic Bonds of Canada Regulations, or
 - (c) registered as to principal or as to principal and interest in the name of the Receiver General for Canada pursuant to the Domestic Bonds of Canada Regulations.
- 9) Tender security shall lapse or be returned as soon as practical following
- (a) the tender closing date, for those Tenderers submitting non-compliant tenders; and
 - (b) the administrative tender review, for those Tenderers submitting compliant tenders ranked fourth to last on the schedule of tenders;
 - (c) the award of contract, for those Tenderers submitting the second and third ranked tenders;
 - (d) the receipt of contract security, for the successful Tenderer; or
 - (e) the cancellation of the tender call, for all Tenderers.
- 10) Notwithstanding the provisions of paragraph 9) herein and provided more than three compliant tenders have been received, if one or more of the tenders ranked third to first is withdrawn or rejected for whatever reason, then Canada reserves the right to hold the security of the next highest ranked compliant tender in order to retain the tender security of at least three valid and compliant tenders.

IT19 CONTRACT SECURITY REQUIREMENTS

- 1) The successful Tenderer shall be required to provide contract security in accordance with the Contract Security Conditions of the tender documents listed above within fourteen (14) days after receipt of a notice in writing that the tender was accepted by Canada.

IT20 CAPITAL DEVELOPMENT AND RE-DEVELOPMENT CHARGES

Tenderers shall not include any monies in the tender amount for special municipal development, re-development or other fees or charges which a municipal authority may seek as a prerequisite to the issuance of building permits.

IT21 BID DEPOSITORY

If the tender advertisement for the work states that a Bid Depository shall be used for specified parts of the Work, the Tenderer shall

- (a) Obtain bids for the specified parts through the Bid Depository according to local Bid Depository rules; and

**1 SECTION 1
INSTRUCTIONS TO TENDERERS (IT)**

(b) Instruct all trade contractors bidding directly to the Tenderer to tender on the scope of the work as defined in local Bid Depository rules (e.g. trade definitions, specification sections etc.).

IT22 REGISTRY AND PRE-QUALIFICATION OF FLOATING PLANT

Dredges or other floating plant to be used in the performance of the work must be on Canadian registry. For dredges or other floating plant which are not of Canadian make or manufacture, the Tenderer must obtain a certificate of qualification from Industry Canada as described in the Floating Plant Appendix of the Tender Form, and this certificate must accompany the tender. Plant so qualified by Industry Canada may be accepted on this dredging project.

IT23 CONTRACTOR PERFORMANCE EVALUATION REPORT (CPER)

1. All projects contracted by Environment Canada will be evaluated on Time, Management and Quality of Workmanship.
2. A completed CPER will be provided to contractors at the successful completion of project work valued at \$10,000 or more, or when the work is taken out of a contractor's hands as a result of a default.
3. For contracts under \$10,000, a CPER will be provided to contractors if it is felt the performance would rate 80 and over or under 55.
4. Bidding privileges will be suspended indefinitely if:
 - (a) a contractor received an overall point rating of 20 or less; or
 - (b) a zero rating on Time or Management; or
 - (c) two overall point ratings between 50 and 25.

IT24 DRAWINGS AND SPECIFICATIONS

1. The "Specifications and Drawings" for construction work will be available to Tenderers. Please send your request by email to the Contracting Authority:
marie-christine.blais@ec.gc.ca or by phone at (514) 496-1929.
2. Each Tenderer will be entitled only to one set of "Specifications and Drawings".

2 SECTION 2 PROJECT BRIEF

2 SECTION 2 PROJECT BRIEF

Construction and installation of a field lab at EC'S sample site situated at Wolfe Island, (On)

CONTEXT

In 1976, Environment Canada established a monitoring station on the St. Lawrence River at Wolfe Island (Figure 1) to estimate annual chemical loads and changes/trends in these loads. Since then, samples have been taken on a regular basis to measure the concentrations of chemicals and nutrients in both dissolved and particulate phases.

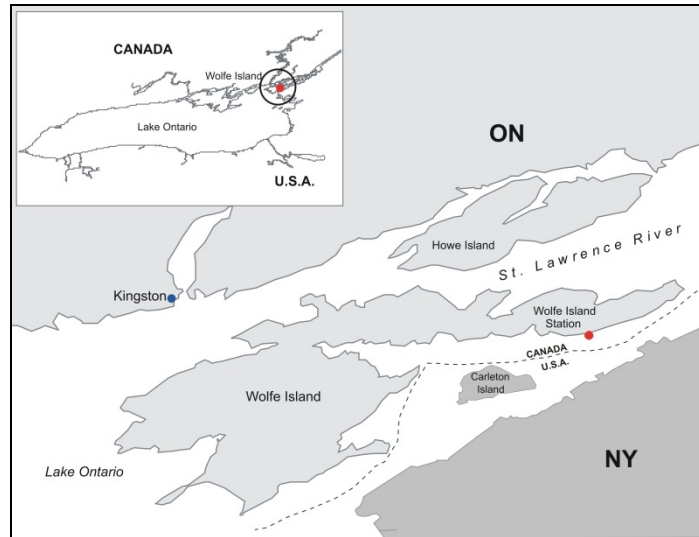

FIGURE 1. Wolfe Island Sampling Site Location

Built in the mid-1980s, the current laboratory structure at Wolfe Island has served as a highly functional location for water quality sampling and analysis. As the monitoring program has evolved, several ad hoc improvements have been implemented but not necessarily in the most effective and efficient manner possible. At the same time, the physical structure has begun to deteriorate after close to 30 years of service despite considerable maintenance effort by Environment Canada staff.

LOCATION:

The construction/sample site is located at 5365 Highway 96, Wolfe Island, Ontario (K0H 2Y0).

SCHEDULE

Project must achieve final completion by **November 28, 2014**

SCOPE OF WORK

To replace the laboratory building at Environment Canada's Wolfe Island water quality monitoring location with a modern permanent building outfitted with up-to-date plumbing and electrical fixtures as well as functional workspace and storage.

SPECIFICATION

Construction will be in accordance with the accompanying Engineering drawings attached.

PARTS /TOOLS AND MATERIAL

The Contractor must provide all instruments, tools, equipment (or parts) and materials required for the contract. All materials supplied by the Contractor must be new. The Contractor is responsible for delivery of all materials to the site.

2 SECTION 2 PROJECT BRIEF

Where materials are supplied by Environment Canada, the Contractor must, unless specified otherwise, take possession of the supplied materials at their storage site, transport them to their installation site, inspect them promptly and advise the departmental representative of any damaged or defective materials. Install and connect finished products according to instructions.

PROCEDURES

The Contractor is responsible for coordinating all on-site work through its foreman. Should unforeseen circumstances arise at the site during performance of the work, this foreman is to advise the departmental representative with a view to agreeing on a new estimate and adjusting the subsequent purchase order as a result.

COOPERATION

The Contractor is to cooperate with the Department's other contractors and/or employees. The Contractor is to make all necessary arrangements with the departmental representative prior to starting the work. The Contractor shall advise the departmental representative upon arriving at the site, leaving the site during the work for any reason and leaving the site at the end of the work.

QUALITY OF WORK

The work is to be performed according to professional standards (recognized best practices). If, at the time of inspection, the departmental representative observes any structure to be non-compliant, the Contractor is to carry out all necessary rework at its own cost within a period of 48 hours.

The Contractor must have at hand all specialized equipment and skilled workers required to complete all work on its own. The departmental representative reserves the right to charge to the Contractor any labour or material costs incurred by Environment Canada while assisting the Contractor in performing the work.

Compliance with Safe Work Practices & Health and Safety Policies

The Contractor must meet or exceed site safe working policies and comply with site security policies. The Contractor shall reference and utilize all applicable site Health and Safety Policies and Procedures in carrying out their work on site.

The Contractor must comply with all safety measures relating to risk of fire or accident and other measures recommended pursuant to national and provincial codes and prescribed by authorities with jurisdiction over work materials, methods and practices.

The Contractor must also take all necessary safety measures and precautions in accordance with current safety standards to protect persons and property from any accident or damage during the provision of maintenance or repair services. The Contractor assumes responsibility for the safety of its staff and for occupational health and safety stemming from the work that the Contractor is carrying out. The Contractor assumes full responsibility for the security of its equipment and materials at all times. Environment Canada shall not be held responsible for vandalism, theft or loss.

CLEANING

During work, keep the work site clean and free of trash and debris. Place volatile waste in covered metal containers and empty them daily. Debris accumulation on work sites is unacceptable.

After each shift, leave the work site clean and free of trash, debris, materials, tools and equipment. Make sure the cleaning is done to the departmental representative's satisfaction.

Empty the waste off federal property, respecting all federal, provincial and municipal environmental protection regulations. Waste also includes demolition materials not saved by the federal government. For toxic products and water containing suspended solids, obtain approval for disposal from the departmental representative.

For waste requiring disposal, the Contractor is responsible for finding a site where dumping is authorized and paying any fees required by the site's owner.

2 SECTION 2 PROJECT BRIEF

PRODUCT AND IMPLEMENTATION REQUIREMENTS

As regards the implementation details not mentioned in the statement of work, carry out work in accordance with good practice (recognized best practices) and to the full satisfaction of the departmental representative. If need be, submit proposals to the departmental representative for approval before work begins.

Perform the work in accordance with the standards and codes in force in Canada

INSPECTION AND CONTROL

Submit all work for inspection and acceptance by the departmental representative and be at the departmental representative's disposal during the inspection of the work.

EVALUATION CRITERIA

Projects are evaluated on best value to the Crown.

The contractor must have a minimum 5 years' experience working on projects of similar size and scope. With the bid, provide a sample of 3 similar projects completed in during the past 5 years. Contractor is to keep a current copy of all required licenses and training certificates for all areas in the scope of work. This information is requested in Appendix 1 of the Tender form. Failure to complete this form or to comply with the requirement for previous experience may result in elimination from the tender process.

The contractor must supply a list of subcontractors and suppliers as itemized in Appendix 2 of the Tender form. Failure to supply this list may result in the elimination of the contractor from the tender process.

The contractor must supply a price breakdown as requested in Appendix 3 of the Tender form. Failure to provide this breakdown may result in elimination from the tender process.

The contract will be awarded based on best value to the Crown. This will be evaluated based on the previous experience of the firm (pass or fail), provision of a list of subcontractors and suppliers (pass or fail), and provision of a price breakdown (pass or fail). The lowest priced tender that meets the above three requirements may be deemed to represent best value to the Crown.

**3 SECTION 3
TENDER AND ACCEPTANCE FORM (TA)**

3 SECTION 3 TENDER ACCEPTANCE FORM (TA)

TA01 PROJECT IDENTIFICATION AND SECURITY

1) Project Identification

- (a) Project Name: **Construction and installation of a field lab at EC'S sample site situated at Wolfe Island, (On)**
- (b) Location: The construction/sample site is located at 5365 Highway 96, Wolfe Island, Ontario (K0H 2Y0)
- (c) Description of Work: Construction and installation of a field lab
- (d) Solicitation Number: **KW405-14-5720**

2) Security Requirements

- (a) The security requirements for this project is
 None
 Reliability
 Secret
- (b) Company security clearance number: _____
- (c) Security level: _____
- (d) Date received: _____
- (e) Expiry date: _____

TA02 BUSINESS NAME AND ADDRESS OF TENDERER

Name: _____

Address: _____

Telephone () - _____
Area Code Number

Facsimile () - _____
Area Code Number

G.S.T. No: _____

TA03 OFFER

- 1) The Tenderer, hereinafter referred to as the Contractor, has carefully examined the Plans and Specifications and the other Tender Documents listed in the Instructions to Tenderers and understands and accepts the provisions as expressed therein. The Tenderer offers to Canada as represented by the Minister of Environment Canada (hereinafter referred to as the Minister) to furnish all necessary labour, Plant, Material, tools and equipment, to execute and complete, in a careful and workmanlike manner, the Work as set out in the Plans and Specifications for the:

- (a) Lump Sum Amount as set out in TA 5; or

**3 SECTION 3
TENDER AND ACCEPTANCE FORM (TA)**

- (b) Total Unit Price Amount as set out in TA 6; or
(c) Total Tender Amount of \$ _____,
Goods and Services Tax/Provincial Sale Tax/Harmonized Sale Tax (GST/PST/HST) extra,
which is the sum of the Amounts set out in TA5 and TA 6 of this Tender and Acceptance
Form.
- 2) The above amount is inclusive of all applicable Federal, Provincial and Municipal taxes. In the event of a change of any tax, customs or other duty, charge, or any similar imposition that is imposed under sales or excise tax legislation of the Government of Canada or provincial or territorial legislation, that effects the Contractor's cost of the Work, and that occurs
(a) after the date this tender was mailed or delivered, or
(b) if this tender is revised, after the date of the last revision was mailed or delivered.
- the amount of this offer shall be increased or decreased in the manner provided for in GC5.3 INCREASED OR DECREASED COSTS, of the General Conditions of the Contract.
- 3) For the purposes of this Tender, Goods and Services Tax/Provincial Sale Tax/Harmonized Sale Tax (if applicable) (GST/PST/HST) are not to be considered as an applicable tax.
- 4) The offer is made subject to the provisions contained in the Tender Documents referred to in IT01.
- 5) The tender shall not be withdrawn for a period of 120 days following the date of tender closing.
- 6) The tender supersedes and cancels all prior communications, negotiations and agreements relating to the work other than contained in the completed tender.
- 7) The Specifications and/or Scope of Work are included with the Tender package. The Plans and Drawings will be distributed by the Minister, upon Tenderers request placed by e-mail to the Contracting Authority named on the Tender Cover.

TA04 ADDENDA (MANDATORY)

- 1) By submission of this tender, the Tenderer confirms having read and understood the requirements expressed in all addenda up to and including Addendum No. _____ and have included all costs of these requirements in Total Tender Amount.

Failure to enter the correct number of the last Addenda issued, may render the Tender liable for disqualification.

TA05 APPENDICES

- 1) The Tender includes Appendix No(s). 1, 2, 3 and 4 to the Tender and Acceptance Form.

TA06 ACCEPTANCE AND CONTRACT

- 1) Upon acceptance of the Contractor's offer by Canada, a binding Contract shall be issued between Canada and the Contractor. The documents forming the Contract shall be the documents referred to in GC1.2 CONTRACT DOCUMENTS of the General Conditions.

TA07 CONSTRUCTION TIME

- 1) The Contractor shall diligently perform and complete the Work in a careful and workmanlike manner.

**3 SECTION 3
TENDER AND ACCEPTANCE FORM (TA)**

- 2) The Contractor shall commence the Work when so instructed by Canada, and shall diligently do and fulfill everything required of the Contractor by the Contract and, subject to any adjustment as provided for in the Contract, complete the work no later **than November 28, 2014**.
- 3) The date the Contractor is to complete the work, as mentioned in paragraph 2) herein, shall be determined by Canada after acceptance of the successful tender. The number of calendars days referred to in paragraph 1) will be added to the effective date of the notification of acceptance of the offer to determine the completion date.

TA08 UNIT PRICE TABLE

- 1) The Contractor agrees that
 - (a) the Unit Price Table designates that part of the Work to which a Unit Price Arrangement applies. Work not designated in the Unit Price Table is that part of the Work to which a Lump Sum Arrangement applies. If no work is designated in the Unit Price Table, a Lump Sum Arrangement applies to the total Work;
 - (b) the Price per Unit and the Estimated Total Price must be entered for each Item listed;
 - (c) the Price per Unit as tendered governs in calculating the Total Estimated Amount, and any errors in the extension of the Price per Unit and in the addition of the Estimated Total Prices will be corrected by Canada in order to obtain the Total Estimated Amount; and
 - (d) the table located in Appendix 4 herein is the Unit Price Table for the purposes of the tender and the Contract:

TA09 TENDER SECURITY

- 1) If tender security is required pursuant to the tender security requirements contained in IT20, the Contractor shall enclose tender security with its tender in accordance with those requirements.
- 2) If the security furnished does not comply fully with the requirements referred to in paragraph 1) herein, the tender shall be disqualified.
- 3) If a security deposit is furnished as tender security, it shall be forfeited in the event that the tender is accepted by Canada and the Contractor fails to provide Contract Security in accordance with IT21 and TA10, provided that the Minister may, if it is in the public interest, waive the right of Canada to forfeiture of the security deposit.

TA10 CONTRACT SECURITY

- 1) If tender security is required in accordance with TA09, the Contractor shall furnish Contract Security in accordance with GC9 CONTRACT SECURITY, upon receipt of written notification of acceptance of the tender.
- 2) Contract Security referred to herein, if provided in the form of a bill of exchange, bank draft or money order will be deposited into the Consolidated Revenue Fund of Canada.

**3 SECTION 3
TENDER AND ACCEPTANCE FORM (TA)**

TA11 EXECUTION OF PROPOSAL

SIGNED, ATTESTED TO AND DELIVERED on the ____ day of _____, 2013 on behalf of

(Type or Print the Business Name of the Tenderer)

WITNESSES

AUTHORIZED SIGNATORY(IES)

(Signature of Witness)

(Signature of Signatory)

(Print Name & Title of Signatory)

(Signature of Witness)

(Signature of Signatory)

(Print Name & Title of Signatory)

SEAL

The Tenderer shall refer to IT05 of Instructions to Tenderers for instructions on required signatures.

**3 SECTION 3
TENDER AND ACCEPTANCE FORM (TA)**

Appendix 1 Completed Projects

I/We have, in the past five (5) years, completed the following three (3) projects which are similar in nature and scope of work to the project for which the present offer is made:

PROJECT NO.	DESCRIPTION (Describe your role in the project and list similarities to this project)	LOCATION	YEAR	COST	CONTACT'S NAME & TELEPHONE
1.					
2.					
3.					

**3 SECTION 3
TENDER AND ACCEPTANCE FORM (TA)**

Appendix 3 Breakdown of Major Item Prices

The following is a breakdown of major item prices, inclusive of supply and installation cost, which are included in the total Tender Price submitted by: _____ (enter name of Tenderer) in the completion of works for this project.

ITEM	PRICE
Total Tendered Amount	\$
GST/PST/H.S.T.	\$
Total Tender Price	\$

**3 SECTION 3
TENDER AND ACCEPTANCE FORM (TA)**

Appendix 4 UNIT PRICE TABLE NOT USED

Note: This unit price table will establish unit costs should there be any additional works required. They will have no bearing on the contract award which is solely based on the lump sum amount.

Item	Col. 2 Class of Labour, Plant or Material	Col. 3 Unit of Measure- ment	Col. 4 Estimated Total Quantity	Col. 5 Price per Unit - GST extra	Col. 6 Estimated Total Price – GST extra
Not Applicable					

**4 SECTION 4
CONTRACT DOCUMENTS - ARTICLES OF AGREEMENT**

4 SECTION 4 CONTRACT DOCUMENTS – ARTICLES OF AGREEMENT “A” R0200C (2004-12-10)

These *Articles of Agreement* made this ____ day of _____ 2014,

Between

Canada represented by the Minister of the Environment (referred to in the contract documents as the "Minister")

and

Contractor (name, address, tel, fax and e-mail:) (referred to in the contract documents as the "Contractor")

Canada and the Contractor agree as follows:

A1 Contract Documents

1.1 The Articles of Agreement, General Conditions and clauses identified herein by title, number and date are hereby incorporated by reference into and form part of this Contract:

1.1.1 These Articles of Agreement (AA),

1.1.2 The documents attached hereto as Appendix “A” entitled “Statement of Work”

1.1.3 The documents attached hereto as Appendix “B” entitled “Terms of Payments”

1.1.4 The documents attached hereto as Appendix “C” entitled “General Conditions (GC)”
of the Contract

GC1 General Provisions

GC2 Administration of the Contract

GC3 Execution and Control of the Work

GC4 Protective Measures

GC5 Terms of Payment

GC6 Delays and Changes in the Work

GC7 Default, Suspension or Termination of Contract

GC8 Dispute Resolution

GC9 Contract Security

GC10 Insurance

GC11 Fair Wages and Hours of Labour - Labour Conditions

1.1.5 The documents attached hereto as Appendix “D” entitled “Supplementary Conditions (SC)”
of the Contract

SC1 Employment Equity

SC2 Work Force Reduction Program

SC3 Intellectual Property

SC4 International Sanctions

1.1.6 The documents attached herein entitled specifications, plans and drawings

1.1.7 Work site specific safety requirements (contained in the specifications document)

1.1.8 Any addenda issued before the date set for tender closing.

1.1.9 Any amendment of the contract documents that is made in accordance with the General Conditions.

A2 Appropriate Law

2.1. This contract shall be governed by and construed in accordance with the laws in force in the Province of Ontario.

4 SECTION 4
CONTRACT DOCUMENTS - ARTICLES OF AGREEMENT

A3 Completion and Description of Work

1. The Contractor shall, between the date of these Articles of Agreement and 28th day of November, 2014 perform and complete with care, skill, diligence and efficiency the work described in this document.

A4 Contract Amount

- 4.1. Subject to any increase, decrease, deduction, reduction or set-off that may be made under the contract, Canada shall pay the Contractor at the times and in the manner that is set out in the Terms of Payments

4.1.1 the sum of \$_____, GST, PST or HST (if applicable) extra, in consideration for the performance of the work or the part thereof that is subject to a "Fixed Price Arrangement", or that part of the contract that prescribes a lump sum as payment for performance of the work to which it relates. and

4.1.2 a sum that is equal to the aggregate of the products of the number of units of measurement of each class of labour, plant and material that is set out in a Final Certificate of Measurement, multiplied in each case by the appropriate unit price, GST, PST or HST (if applicable) extra, that is set out in the Unit Price Table in consideration for the performance of the work or the part thereof that is subject to a "Unit Price Arrangement", or that part of the contract that prescribes the product of a price multiplied by number of units of measurement of a class as payment for performance of the work to which it relates.

4.2 The total amount payable by Canada to the Contractor shall not exceed: \$_____

A5 Unit Price Table

5.1 The following table is the Unit Price Table for the purposes of the contract:

Column 1	Column 2	Column 3	Column 4	Column 5	Column 6
Item	Class of Labour, Plant or Material	Unit of Measurement	Estimated Total Quantity	Price per Unit	Estimated Total Price
N/A					

A6 Departmental Representative

6.1. For the purpose of this Contract, the Minister designates, as Departmental Representative:

The name and contact information of the Technical Authority shall be known upon contract award.

6.2. The Departmental Representative is responsible for all matters concerning the professional and technical content of the work under this contract. Any proposed changes to the scope of the work are to be discussed with the Departmental Representative but any resultant changes can only be authorized by contract amendment issued by the Contracting Authority.

A7 Contracting Authority

7.1. For the purpose of this Contract, the Minister designates, as Contracting Authority:

4 SECTION 4
CONTRACT DOCUMENTS - ARTICLES OF AGREEMENT

Marie-Christine Blais
Environnement Canada
Procurement and Contracting Division
Finance Branch
105 McGill 5th floor
Montreal (Quebec) H2Y 2E7
Phone : (514) 496-1929
Fax : (514) 283-4439
Email : marie-christine.blais@ec.gc.ca

- 7.2. The Contracting Authority named above is responsible for the management of this contract. The Contractor is not to work in excess or outside the scope of this contract based on instructions from any government personnel other than the aforementioned Contracting Authority. No change or modification to the Contract shall become binding unless it is incorporated into the Contract by written amendment.

4 SECTION 4
CONTRACT DOCUMENTS - ARTICLES OF AGREEMENT

IN WITNESS WHEREOF the parties hereto have executed these Articles of Agreement as of the day and year first above written.

FOR LIMITED COMPANY OR INCORPORATED COMPANY SEALED, ATTESTED TO AND DELIVERED
on behalf of the Contractor by

(Signature of Authorized Signatory) (Print Name of Signatory) Date _____

in the presence of _____
(Print Title of Signatory)

(Signature of Witness)

(Signature of Authorized Signatory) (Print Name of Signatory)

in the presence of _____
(Print Title of Signatory) (Corporate Seal)

(Signature of Witness)

EXECUTED ON BEHALF OF Her Majesty by

(Signature of Authorized Departmental Officer) (Print Name of Officer) Date _____

in the presence of _____
(Print Title of Officer)

Signature of Witness

and countersigned by

(Signature of Authorized Departmental Officer) (Print Name of Officer) Date _____

(Print Title of Officer)

**4 SECTION 4
CONTRACT DOCUMENTS - ARTICLES OF AGREEMENT**

FOR PARTNERSHIP OR SOLE PROPRIETORSHIP SEALED, ATTESTED TO AND DELIVERED on behalf of the Contractor by

(Signature of Partner/Sole Proprietor)

(Print name of Partner/Sole Proprietor) (Seal)

Date

in the presence of

(Signature of Witness)

(Signature of Partner)

(Print Name of Partner)

(Seal)

Date

in the presence of

(Signature of Witness)

Date

EXECUTED ON BEHALF OF Her Majesty by

(Signature of Authorized Departmental Officer)

(Print Name of Officer)

Date

in the presence of

(Print Title of Officer)

Signature of Witness

and countersigned by

(Signature of Authorized Departmental Officer)

(Print Name of Officer)

Date

(Print Title of Officer)

5 SECTION 5
CONTRACT DOCUMENTS – Appendix “A” Statement of Work (SOW)

5 SECTION 5 CONTRACT DOCUMENTS – STATEMENT OF WORK

Refer to Drawings and Specification

6 SECTION 6
CONTRACT DOCUMENTS – Appendix “B” Terms of Payments (TP)

6 SECTION 6 CONTRACT DOCUMENTS – TERMS OF PAYMENT

Refer to Section 7 – GC 5 -General Conditions – Terms of Payment

7 SECTION 7 CONTRACT DOCUMENTS GENERAL CONDITIONS (GC) R0202D (2004-05-14)

Appendix “C” General Condition (GC)

GC1 GENERAL PROVISIONS

GC1.1 INTERPRETATION

GC1.1.1 Headings and References

- 1) The headings in the contract documents, other than those in the drawings and specifications, form no part of the Contract but are inserted for convenience of reference only.
- 2) A reference made to a part of the Contract by means of numbers preceded by letters is a reference to the particular part of the Contract that is identified by that combination of letters and numbers and to any other part of the Contract referred to therein.
- 3) A reference to a paragraph or subparagraph followed by an identifying number, letter or combination thereof is, unless specifically stated otherwise, a reference to the paragraph or subparagraph that forms part of the clause within which the reference is made.

GC1.1.2 Terminology

- 1) In the Contract

"Canada", "Crown", "Her Majesty" means Her Majesty the Queen in right of Canada;

"Contract" means the contract documents referred to as such therein and every other document specified or referred to in any of them as forming part of the Contract, all as amended by agreement of the parties;

"Contract Amount" means the amount set out in the Contract to be payable to the Contractor for the Work, subject to the terms and conditions of the Contract;

"Contract Security" means any security given by the Contractor to Canada in accordance with the Contract;

"Contractor" means the person contracting with Canada to provide or furnish all labour, Material and Plant for the execution of the Work under the Contract, and includes the Contractor's superintendent as designated in writing by the Departmental Representative.

"Departmental Representative" means the person designated in the Contract, or by written notice to the Contractor, to act as the Departmental Representative for the purposes of the Contract, and includes a person, designated and authorized in writing by the Departmental Representative to the Contractor, to perform any of the Departmental Representative's functions under the Contract;

"Final Certificate of Completion" means a certificate issued by the Departmental Representative when the Work reaches Completion;

"Final Certificate of Measurement" means a certificate issued by the Departmental Representative certifying the correctness of the final quantities, unit prices and values of labor, Plant and Material performed, used and supplied by the Contractor for the construction of the part of the Work to which a Unit Price Arrangement applies;

"herein", "hereby", "hereof", "hereunder" and similar expressions refer to the Contract as a whole and not to any particular section or part thereof;

"Interim Certificate of Completion" means a certificate issued by the Departmental Representative when the Work reaches Substantial Completion as defined in the General Terms and Conditions;

7 SECTION 7
CONTRACT DOCUMENTS – Appendix “C” General Conditions (GC)

"Lump Sum Arrangement" means that part of the Contract that prescribes a lump sum as payment for performance of the Work to which it relates;

"Material" includes all commodities, articles, machinery, equipment, fixtures and things required to be furnished in accordance with the Contract for incorporation into the Work;

"Minister" includes a person acting for or, if the office is vacant, in place of the Minister, the Minister's successors in the office, a lawful deputy, and any representative, other than the Departmental Representative, appointed for the purposes of the Contract;

"person" includes, unless otherwise stated in the Contract, any partnership, proprietorship, firm, joint venture, consortium and corporation;

"Plant" includes all tools, implements, machinery, vehicles, structures, equipment, articles and things that are necessary for the performance of the Contract, other than Material and those tools customarily provided by a tradesperson in practicing a trade;

"Subcontractor" means a person having a direct contract with the Contractor, subject to GC3.6 SUBCONTRACTING, to perform a part or parts of the Work, or to supply Material worked to a special design for the Work;

"Superintendent" means the employee or representative of the Contractor designated by the Contractor to act pursuant to GC2.5 SUPERINTENDENT;

"Supplemental Conditions" means the part of the Contract that amends or supplements the General Terms and Conditions;

"Supplier" means a person having a direct contract with the Contractor to supply Plant or Material not worked to a special design for the Work;

"Unit Price Arrangement" means that part of the Contract that prescribes the product of a price per unit of measurement multiplied by a number of units of measurement for performance of the Work to which it relates;

"Unit Price Table" means the table of unit prices set out in the Contract;

"Work" means, subject only to any express stipulation in the Contract to the contrary, everything that is necessary to be done, furnished or delivered by the Contractor to perform the Contract in accordance with the contract documents; and

"Working Day" means a day other than a Saturday, Sunday, or a holiday which is observed by the construction industry in the area of the place of the Work.

GC1.1.3 Application of Certain Provisions

- 1) Any provisions of the Contract that are expressly stipulated to be applicable only to a Unit Price Arrangement are not applicable to any part of the Work to which a Lump Sum Arrangement applies.
- 2) Any provisions of the Contract that are expressly stipulated to be applicable only to a Lump Sum Arrangement are not applicable to any part of the Work to which a Unit Price Arrangement applies.

GC1.1.4 Substantial Performance

- 1) The Work will be considered to have reached Substantial Performance when
 - (a) the Work or a substantial part thereof has passed inspection and testing and is, in the opinion of Canada, ready for use by Canada or is being used for the intended purposes; and
 - (b) the Work is, in the opinion of Canada, capable of completion or correction at a cost of not more than

7 SECTION 7
CONTRACT DOCUMENTS – Appendix “C” General Conditions (GC)

- (i) 3% of the first \$500,000;
 - (ii) 2% of the next \$500,000; and
 - (iii) 1% of the balance
- of the Contract Amount at the time this cost is calculated.

- 2) Where the Work or a substantial part thereof is ready for use or is being used for the purposes intended and
- (a) the remainder of the Work or a part thereof cannot be completed by the time specified in the Contract, or as amended in accordance with GC6.5 DELAYS AND EXTENSION OF TIME, for reasons beyond the control of the Contractor; or
 - (b) Canada and the Contractor agree not to complete a part of the Work within the specified time;

the cost of that part of the Work that was either beyond the control of the Contractor to complete or Canada and the Contractor have agreed not to complete by the time specified, shall be deducted from the value of the Contract referred to in subparagraph 1)(b) of GC1.1.4. and the said cost shall not form part of the cost of the Work remaining to be done in determining Substantial Performance.

GC1.1.5 Completion

- 1) The Work shall be deemed to have reached Completion when all labour, Plant and Material required have been performed, used or supplied, and the Contractor has complied with the Contract and all orders and directions made pursuant thereto, all to the satisfaction of Canada.

GC1.2 CONTRACT DOCUMENTS

GC1.2.1 General

- 1) The documents forming the Contract between Canada and the Contractor, referred to herein as the contract documents, are
- (a) the Invitation to Tender when signed by the Contractor and the Contract, when signed by Canada;
 - (b) the duly completed Tender Acceptance Form (TA) and any Appendices attached thereto;
 - (c) the documents entitled Plans and Specifications, referred to in the Contract as the Plans and Specifications;
 - (d) the General Conditions of the Contract, referred to in the Contract as the General Conditions;
 - (e) the Supplementary General Conditions, if any, referred to in the Contract as the Supplementary General Conditions;
 - (f) the Fair Wages and Hours of Labour - Labour Conditions referred to in the Contract as the Labour Conditions;
 - (g) the Fair Wage Schedules for Federal Construction Contracts referred to in the Contract as the Fair Wage Schedule;
 - (g) any addendum issued or any allowable tender revision received before the date and time set for closing;
 - (h) any addendum incorporated in a contract document by mutual agreement between Canada and the Contractor before the acceptance of the tender; and
 - (i) any amendment or variation of the contract made in accordance with the General Conditions.
- 2) The contract documents are complementary, and what is required by any one document shall be as binding as if required by all documents.
- 3) Nothing contained in the contract documents shall create a contractual relationship between Canada and any Subcontractor or Supplier, their subcontractors or suppliers, or their agents or employees.

GC1.2.2 Order of Precedence

- 1) In the event of any discrepancy or conflict in the contents of the following documents, such documents shall take precedence and govern in the following order:
- (a) any amendment or variation of the contract documents that is made in accordance with the General Conditions;
 - (b) any addenda issued prior to tender closing;

7 SECTION 7
CONTRACT DOCUMENTS – Appendix “C” General Conditions (GC)

- (c) Supplementary General Conditions;
- (d) General Conditions;
- (e) the duly completed Tender and Acceptance Form when accepted;
- (f) Plans and Specifications.

Documents issued at later dates shall govern within each of the above categories of documents.

- 2) In the event of any discrepancy or conflict in the information contained in the Plans and Specifications, the following rules shall apply:
 - (a) Specifications shall govern over Plans;
 - (b) dimensions shown in figures on a Plan shall govern where they differ from dimensions scaled from the same Plan; and
 - (c) Plans of larger scale govern over those of smaller scale.

GC1.2.3 Security and Protection of Documents and Work

- 1) The Contractor shall guard and protect contract documents, drawings, information, models and copies thereof, whether supplied by Canada or the Contractor, against loss or damage from any cause.
- 2) The Contractor shall keep confidential all information provided to the Contractor by or on behalf of Canada in connection with the Work, and all information developed by the Contractor as part of the Work, and shall not disclose any such information to any person without the written permission of Canada, except that the Contractor may disclose to a subcontractor, authorized in accordance with the Contract, information necessary to the performance of a subcontract. This section does not apply to any information that:
 - (a) is publicly available from a source other than the Contractor; or
 - (b) is or becomes known to the Contractor from a source other than Canada, except any source that is known to the Contractor to be under an obligation to Canada not to disclose the information.
- 3) When the Contract, the Work, or any information referred to in paragraph 2) is identified as TOP SECRET, SECRET, CONFIDENTIAL or PROTECTED by Canada, the Contractor shall, at all times, take all measures reasonably necessary for the safeguarding of the material so identified, including such measures as may be further specified elsewhere in the Contract or provided, in writing, from time to time by Canada.
- 4) Without limiting the generality of paragraphs 2) and 3) of GC1.2.3, when the Contract, the Work, or any information referred to in paragraph 2) is identified as TOP SECRET, SECRET, CONFIDENTIAL or PROTECTED by Canada, Canada shall be entitled to inspect the Contractor's premises and the premises of its subcontractors or suppliers and any other person at any tier, for security purposes at any time during the term of the Contract, and the Contractor shall comply with, and ensure that any such subcontractors or suppliers comply with all written instructions issued by Canada dealing with the material so identified, including any requirement that employees of the Contractor and its subcontractors and suppliers and any other person at any tier execute and deliver declarations relating to reliability screenings, security clearances and other procedures.
- 5) The Contractor shall safeguard the Work and the Contract, the Specifications, Plans, drawings and any other information provided by Canada to the Contractor, and shall be liable to Canada for any loss or damage from any causes.

GC1.3 STATUS OF THE CONTRACTOR

- 1) The Contractor is engaged under the Contract as an independent contractor.
- 2) The Contractor, its subcontractors and suppliers and any other person at any tier and their employees are not engaged by the Contract as employees, servants or agents of Canada.
- 3) For the purposes of the contract the Contractor shall be solely responsible for any and all payments and deductions required to be made by law including those required for Canada or Quebec Pension Plans, Employment Insurance, Worker's Compensation, provincial health or insurance plans, and Income Tax.

7 SECTION 7
CONTRACT DOCUMENTS – Appendix “C” General Conditions (GC)

GC1.4 TIME OF THE ESSENCE

- 1) Time is of the essence of the Contract.

GC1.5 INDEMNIFICATION BY CONTRACTOR

- 1) The Contractor shall pay all royalties and patent fees required for the performance of the Contract and, at the Contractor's expense, shall defend all claims, actions or proceedings against Canada charging or claiming that the Work or any part thereof provided or furnished by the Contractor to Canada infringe any patent, industrial design, copyright trademark, trade secret or other proprietary right enforceable in Canada.
- 2) The Contractor shall indemnify and save Canada harmless from and against all claims, demands, losses, costs, damages, actions, suits, or proceedings by whomever made, brought or prosecuted and in any manner based upon, arising out of, related to, occasioned by, or attributable to the activities of the Contractor, its subcontractors and suppliers and any other person at any tier, in performing the Work.
- 3) For the purposes of paragraph 2) of GC1.6, "activities" includes any act improperly carried out, any omission to carry out an act and any delay in carrying out an act.

GC1.6 INDEMNIFICATION BY CANADA

- 1) Subject to the Crown Liability and Proceedings Act, the Patent Act, and any other law that affects Canada's rights, powers, privileges or obligations, Canada shall indemnify and save the Contractor harmless from and against all claims, demands, losses, costs, damage, actions, suits or proceedings arising out of the Contractor's activities under the Contract that are directly attributable to
 - (a) a lack of or a defect in Canada's title to the Work site if owned by Canada, whether real or alleged; or
 - (b) an infringement or an alleged infringement by the Contractor of any patent of invention or any other kind of intellectual property occurring while the Contractor was performing under the Contract employing a model, plan or design related to the Work that was supplied by Canada to the Contractor.

GC1.7 LAWS, PERMITS AND TAXES

- 1) The Contractor shall comply with all federal, provincial and municipal laws and regulations applicable to the performance of the Work or any part thereof including, without limitation, all laws concerning health and labour conditions and the protection of the environment, and shall require compliance therewith by all of its subcontractors and suppliers at any tier as if the work were being performed for an owner other than Canada. The Contractor shall furnish evidence of compliance with such laws and regulations to Canada at such times as Canada may reasonably request.
- 2) Unless stipulated otherwise in the Contract, the Contractor shall obtain and maintain all permits, certificates, licenses, registrations and authorizations required for the lawful performance of the Work.
- 3) Prior to the commencement of the Work at the site, the Contractor shall tender to a municipal authority an amount equal to all fees and charges that would be lawfully payable to that municipal authority in respect of building permits as if the Work were being performed for an owner other than Canada.
- 4) Within ten (10) days of making a tender pursuant to paragraph 3) of GC1.8, the Contractor shall notify Canada of the amount properly tendered and whether or not the municipal authority has accepted that amount.
- 5) If the municipal authority has not accepted the amount tendered, the Contractor shall pay that amount to Canada within six (6) days after the time stipulated in paragraph 4) of GC1.8.
- 6) For the purposes of this clause, "municipal authority" means any authority that would have jurisdiction respecting permission to perform the Work if the owner were not Canada.

7 SECTION 7
CONTRACT DOCUMENTS – Appendix “C” General Conditions (GC)

- 7) Notwithstanding the residency of the Contractor, the Contractor shall pay any applicable tax arising from or related to the performance of the Work under the Contract.
- 8) In accordance with the Statutory Declaration referred to in paragraph 4) of GC5.5 SUBSTANTIAL PERFORMANCE OF THE WORK, a Contractor who has neither residence nor place of business in the province or territory in which work under the Contract is being performed shall provide Canada with proof of registration with the provincial sales tax authorities in the said province.
- 9) For the purpose of the payment of any applicable tax or the furnishing of security for the payment of any applicable tax arising from or related to the performance of the Work, and notwithstanding the provision that all Material, Plant and interest of the Contractor in all real property, licenses, powers and privileges, become the property of Canada after the time of purchase in accordance with GC3.9 MATERIAL PLANT AND REAL PROPERTY BECOME PROPERTY OF CANADA, the Contractor shall be liable, as a user or consumer, for the payment or for the furnishing of security for the payment of any applicable tax payable, at the time of the use or consumption of that Material, Plant or interest of the Contractor in accordance with the relevant legislation.

GC1.8 WORKERS' COMPENSATION

- 1) At the time of submitting its first progress claim, at the time of Substantial Performance of the Work, and prior to issuance of the Certificate of Completion, the Contractor shall provide evidence of compliance with workers' compensation legislation applicable to the place of the Work, including payments due thereunder.
- 2) At any time during the term of the Contract, when requested by Canada, the Contractor shall provide such evidence of compliance by the Contractor, its subcontractors and any other person at any tier and any other person performing part of the Work who is required to comply with such legislation.

GC1.9 NATIONAL SECURITY

- 1) If the Minister determines that the Work is of a class or kind that involves national security, Canada may order the Contractor to
 - (a) provide Canada with any information concerning persons employed or to be employed by the Contractor for purposes of the Contract; and
 - (b) remove any person from the site of the Work if, in the opinion of Canada, that person may be a risk to the national security;and the Contractor shall comply with the order.
- 2) In all contracts with persons and entities employed in the performance of the Contract, the Contractor shall make provision for the performance of any obligation that may be imposed upon the Contractor.

GC1.10 UNSUITABLE WORKERS

- 1) Canada shall instruct the Contractor to remove from the site of the Work any person employed by the Contractor for purposes of the Contract who, in the opinion of Canada, is incompetent or is guilty of improper conduct, and the Contractor shall not permit a person who has been removed to return to the site of the Work.

GC1.11 PUBLIC CEREMONIES AND SIGNS

- 1) The Contractor shall not permit any public ceremony in connection with the Work without the prior consent of Canada.
- 2) The Contractor shall not erect nor permit the display of any sign or advertising on the Work site without the prior consent of Canada.

7 SECTION 7
CONTRACT DOCUMENTS – Appendix “C” General Conditions (GC)

GC1.12 CONFLICT OF INTEREST

- 1) It is a term of the Contract that no individual, for whom the post-employment provisions of the Conflict of Interest and Post-Employment Code for Public Office Holders or the Values and Ethics Code for the Public Service apply, shall derive a direct benefit from the Contract unless that individual is in compliance with the applicable post-employment provisions.

GC1.13 MEMBERS OF HOUSE OF COMMONS NOT TO BENEFIT

- 1) As required by the Parliament of Canada Act, it is an express condition of the Contract that no member of the House of Commons shall be admitted to any share or part of the Contract or to any benefit arising therefrom.

GC1.14 AGREEMENTS AND AMENDMENTS

- 1) The Contract constitutes the entire and sole agreement between the parties with respect to the subject matter of the Contract and supersedes all previous negotiations, communications and other agreements, whether written or oral, relating to it, unless they are incorporated by reference in the Contract. There are no terms, covenants, representations, statements or conditions binding on the parties other than those contained in the Contract.
- 2) The failure of either party at any time to require performance by the other party of any provision hereof shall not affect the right thereafter to enforce such provision. Nor shall the waiver by either party of any breach of any covenant, condition or provision hereof be taken or held to be a waiver of any further breach of the same covenant, condition or provision.
- 3) The Contract may be amended only as provided for and written in the Contract.

GC1.15 SUCCESSION

- 1) The Contract shall inure to the benefit of and be binding upon the parties hereto and their lawful heirs, executors, administrators, successors and, subject to GC1.17 ASSIGNMENT, permitted assigns.

GC1.16 ASSIGNMENT

- 1) The Contractor shall not make any assignment of the Contract, either in whole or in part, without the written consent of the Minister.

GC1.17 NO BRIBE

- 1) The Contractor represents and covenants that no bribe, gift, benefit, nor other inducement has been nor will be paid, given, promised or offered directly or indirectly to any official or employee of Canada or to a member of the family of such a person, with a view to influencing the entry into the Contract or the administration of the Contract.

GC1.18 CERTIFICATION - CONTINGENCY FEES

- 1) The Contractor certifies that it has not directly or indirectly paid nor agreed to pay and covenants that it shall not directly or indirectly pay nor agree to pay a contingency fee for the solicitation, negotiation or obtaining of the Contract to any person other than an employee acting in the normal course of the employee's duties.
- 2) All accounts and records pertaining to payments of fees or other compensation for the solicitation, obtaining or negotiating of the Contract shall be subject to the accounts and audit provisions of the Contract.
- 3) If the Contractor certifies falsely under this section or is in default of the obligations contained therein, Canada may either take the Work out of the Contractor's hands in accordance with the provisions of the Contract or recover from the Contractor by way of reduction to the Contract Amount or otherwise the full amount of the contingency fee.

7 SECTION 7
CONTRACT DOCUMENTS – Appendix “C” General Conditions (GC)

GC2 ADMINISTRATION OF THE CONTRACT

GC2.1 DEPARTMENTAL REPRESENTATIVE’S AUTHORITY

- 1) Canada shall designate a Departmental Representative and shall notify the Contractor of the name, address and telephone number of the Departmental Representative.
- 2) The Departmental Representative shall perform Canada's duties and functions under the contract.
- 3) The Departmental Representative shall be authorized to issue notices, instructions and directions to the Contractor and to accept on behalf of Canada any notice, order or other communication from the contractor relating to the Work.
- 4) The Departmental Representative shall, within a reasonable time, review and respond to submissions made by the Contractor in accordance with the requirements of the Contract.

GC2.2 INTERPRETATION OF CONTRACT

- 1) If, at any time before Canada has issued a Certificate of Completion, any question arises between the parties about whether anything has been done as required by the Contract or about what the Contractor is required by the Contract to do, and in particular but without limiting the generality of the foregoing, about
 - (a) the meaning of anything in the Plans and Specifications;
 - (b) the meaning to be given to the Plans and Specifications in case of any error therein, omission therefrom, or obscurity or discrepancy in their wording or intention;
 - (c) whether or not the quality or quantity of any Material or workmanship supplied or proposed to be supplied by the Contractor meets the requirements of the Contract;
 - (d) whether or not the labour, Plant or Material performed, used and supplied by the Contractor for performing the Work and carrying out the Contract are adequate to ensure that the Work shall be performed in accordance with the Contract and that the Contract shall be carried out in accordance with its terms;
 - (e) what quantity of any of the Work has been completed by the Contractor; or
 - (f) the timing and scheduling of the various phases of the performance of the Work as specified in the Contract;

the question shall be decided, subject to the provisions of GC8 DISPUTE RESOLUTION, by Canada.

- 2) The Contractor shall perform the Work in accordance with any decisions of Canada that are made under paragraph 3) of GC2.2 and in accordance with any consequential directions given by Canada.
- 3) If the Contractor fails to comply with any instruction or direction issued by Canada pursuant to the Contract, Canada may employ such methods as Canada deems advisable to do what the Contractor failed to do, and the Contractor shall, on demand, pay Canada an amount that is equal to the aggregate of all costs, expenses and damages incurred or sustained by Canada by reason of the Contractor's failure to comply with such instruction or direction, including the cost of any methods employed by Canada in doing what the Contractor failed to do.

GC2.3 NOTICES

- 1) Subject to paragraph 3) of GC2.3, any notice, order or other communication may be given in any manner, and if required to be in writing, shall be addressed to the party to whom it is intended at the address in the Contract or at the last address of which the sender has received written notice in accordance with this section.

7 SECTION 7
CONTRACT DOCUMENTS – Appendix “C” General Conditions (GC)

- 2) Any notice, order or other communication given in writing in accordance with paragraph 1) of GC2.3 shall be deemed to have been received by either party
 - (a) if delivered personally, on the day that it was delivered;
 - (b) if forwarded by mail, on the earlier of the day it was received or the sixth day after it was mailed; and
 - (c) if forwarded by facsimile or electronic mail, 24 hours after it was transmitted.
- 3) A notice given under GC7.1 TAKING THE WORK OUT OF THE CONTRACTOR'S HANDS, GC7.2 SUSPENSION OF WORK, and GC7.3 TERMINATION OF CONTRACT shall be given in writing and, if delivered personally, shall be delivered, if the Contractor is a sole proprietor, to the Contractor or, if the Contractor is a partnership or corporation, to an officer thereof.

GC2.4 SITE MEETINGS

- 1) In consultation with Canada, the Contractor shall arrange site meetings at regular intervals, with all involved parties who are to attend, in order to ensure, among other things, the proper co-ordination of the Work.

GC2.5 REVIEW AND INSPECTION OF WORK

- 1) Canada shall review the Work to determine if it is proceeding in conformity with the Contract and to record the necessary data to make an assessment of the value of Work completed. Canada shall measure and record the quantities of labour, Plant and Material performed, used or supplied by the Contractor in performing the Work or any part thereof that is subject to a Unit Price Arrangement and, on request, shall inform the Contractor of those measurements, and permit the Contractor to inspect any records pertaining thereto.
- 2) Canada shall reject Work or Material which in Canada's opinion does not conform to the requirements of the Contract, and shall require inspection or testing of Work, whether or not such Work is fabricated, installed, or completed. If such Work is not in accordance with the requirements of the Contract, the Contractor shall correct the Work and shall pay Canada, on demand, all reasonable costs and expenses that were incurred by Canada in having the examination performed.
- 3) The Contractor shall provide Canada with access to the Work and its site at all times, and at all times shall provide sufficient, safe, and proper facilities for the review and inspection of the Work by persons authorized by Canada and any representatives of those authorities having jurisdiction. If parts of the Work are in preparation at locations other than the site of the Work, Canada shall be given access to such Work whenever it is in progress.
- 4) The Contractor shall furnish Canada with such information respecting the performance of the Contract as Canada may require, and render every possible assistance to enable Canada to verify that the Work is performed in accordance with the Contract, carry out any other duties and exercise any powers in accordance with the Contract.
- 5) If Work is designated for tests, inspections, or approvals in the Contract or by Canada's instructions, or by laws or ordinances of the place of the Work, the Contractor shall give Canada reasonable notice of when such Work shall be ready for review and inspection. The Contractor shall arrange for and shall give Canada reasonable notice of the date and time of inspections, tests or approvals.
- 6) If the Contractor covers, or permits to be covered, Work that has been designated for tests, inspections or approvals before such tests, inspections or approvals are made, completed or given, the Contractor shall, if so directed by Canada, uncover such Work, have the inspections, tests or approvals satisfactorily made, completed or given and make good the covering of the Work at the Contractor's expense.

7 SECTION 7
CONTRACT DOCUMENTS – Appendix “C” General Conditions (GC)

GC2.6 SUPERINTENDENT

- 1) Prior to commencing the Work, the Contractor shall designate a Superintendent and shall notify Canada of the name, address and telephone number of the Superintendent. The Contractor shall keep the Superintendent at the Work site during working hours until the Work has reached completion.
- 2) The Superintendent shall be in full charge of the operations of the Contractor during the performance of the Work and shall be authorized to accept on behalf of the Contractor any notice, order or other communication given to the Superintendent or the Contractor relating to the Work.
- 3) Upon request of Canada, the Contractor shall remove any Superintendent who, in the opinion of Canada, is incompetent or has been guilty of improper conduct, and shall forthwith designate another Superintendent who is acceptable to Canada.
- 4) The Contractor shall not substitute a Superintendent without the written consent of Canada. If a Superintendent is substituted without such consent, Canada shall be entitled to refuse to issue any documentation or certification relating to progress payments, Substantial Performance or Completion of the Work until the Superintendent has returned to the Work site or another Superintendent who is acceptable to Canada has been substituted.

GC2.7 NON-DISCRIMINATION IN HIRING AND EMPLOYMENT OF LABOUR

- 1) For the purposes of this clause, “persons” include the Contractor, its subcontractors and suppliers at any tier and their respective employees, agents, licensees or invitees and any other individual involved in the performance of the Work or granted access to the Work site. A “person” includes any partnership, proprietorship, firm, joint venture, consortium and corporation.
- 2) Without restricting the provisions of paragraph 3) of GC2.6, SUPERINTENDENT, the Contractor shall not refuse to employ and shall not discriminate in any manner against any person because
 - (a) of that person's race, national origin, colour, religion, age, sex or marital status;
 - (b) of the race, national origin, colour, religion, age, sex, or marital status of any person having any relationship or association with that person; or
 - (c) a complaint has been made or information has been given by or in respect of that person relating to an alleged failure by the Contractor to comply with subparagraphs 2)(a) and 2)(b) of GC2.7.
- 3) Within two Working Days immediately following receipt of a written complaint pursuant to paragraph 2) of GC2.7, the Contractor shall
 - (a) cause to have issued a written direction to the person or persons named by the complainant to cease all actions that form the basis of the complaint;
 - (b) forward a copy of the complaint to Canada by registered mail or courier service; and
 - (c) when the Labour Conditions are applicable under the circumstances of the complaint, forward a copy of the complaint to HRDC - Labour to the attention of the appropriate Director as described in the Labour Conditions (“HRDC - Labour” means the labour component of the federal Department of Human Resources Development).
- 4) Within twenty four (24) hours immediately following receipt of a direction from Canada to do so, the Contractor shall cause to have removed from the site of the Work and from the performance of Work under the Contract, any person or persons whom Canada believes to be in breach of the provisions of paragraph 2) of GC2.7.
- 5) No later than thirty (30) days after receipt of the direction referred to in paragraph 4) of GC2.7, the Contractor shall cause the necessary action to be commenced to remedy the breach described in the direction.

7 SECTION 7
CONTRACT DOCUMENTS – Appendix “C” General Conditions (GC)

- 6) If a direction is issued pursuant to paragraph 4) of GC2.7, Canada may withhold from monies that are due and payable to the Contractor or setoff pursuant to GC5.9 RIGHT OF SETOFF, whichever is applicable, an amount representing the sum of the costs and payment referred to in paragraph 8) of GC2.7.
- 7) If the Contractor fails to proceed in accordance with paragraph 5) of GC2.7, Canada shall take the necessary action to have the breach remedied, and shall determine all supplementary costs incurred by Canada as a result.
- 8) Canada may make a payment directly to the complainant from monies that are due and payable to the Contractor upon receipt from the complainant of
 - (a) a written award issued pursuant to the federal Commercial Arbitration Act, R.S.C. 1985, c. 17 (2nd Supp.);
 - (b) a written award issued pursuant to the Canadian Human Rights Act, R.S.C. 1985, c. H-6;
 - (c) a written award issued pursuant to provincial or territorial human rights legislation; or
 - (d) a judgement issued by a court of competent jurisdiction.
- 9) If Canada is of the opinion that the Contractor has breached any of the provisions of this clause, Canada may take the Work out of the Contractor's hands pursuant to GC 7.1 TAKING THE WORK OUT OF THE CONTRACTOR'S HANDS.
- 10) Subject to paragraph 7) of GC3.6 SUBCONTRACTING, the Contractor shall ensure that the provisions of this clause are included in all agreements and contracts entered into as a consequence of the Work.

GC2.8 ACCOUNTS AND AUDITS

- 1) The Contractor shall, in addition to the requirements expressed in paragraph 5) of GC3.4 EXECUTION OF THE WORK, maintain full records of the Contractor's estimated and actual cost of the Work together with all tender calls, quotations, contracts, correspondence, invoices, receipts and vouchers relating thereto, and shall make them available on request to audit and inspection by Canada and the Deputy Receiver General for Canada or by persons designated to act on behalf of either or both of them.
- 2) The Contractor shall allow any of the persons referred to in paragraph 1) of GC2.8 to make copies of and take extracts from any of the records and material, and shall furnish such persons or entities with any information those persons or entities may require from time to time in connection with such records and material.
- 3) The Contractor shall maintain and keep the records intact until the expiration of two years after the date that a Certificate of Completion has been issued or until the expiration of such other period of time as Canada may direct.
- 4) The Contractor shall cause all subcontractors at any tier and all other persons directly or indirectly controlled by or affiliated with the Contractor and all persons directly or indirectly having control of the Contractor to comply with the requirements of this clause as if they were the Contractor.

GC3 EXECUTION AND CONTROL OF THE WORK

GC3.1 PROGRESS SCHEDULE

- 1) The Contractor shall
 - (a) prepare and submit to Canada, prior to the submission of the Contractor's first progress claim, a progress schedule in accordance with the requirements set out in the Contract;

7 SECTION 7
CONTRACT DOCUMENTS – Appendix “C” General Conditions (GC)

- (b) monitor the progress of the Work relative to the schedule and update the schedule as stipulated by the contract documents;
- (c) advise Canada of any revisions to the schedule required as the result of any extension of time for completion of the Contract that was approved by Canada; and
- (d) prepare and submit to Canada, at the time of issuance of an Certificate of Substantial Performance, an update of any schedule clearly showing a detailed timetable that is acceptable to Canada for the completion of any unfinished Work and the correction of all listed defects.

GC3.2 ERRORS AND OMISSIONS

- 1) The Contractor shall report promptly to Canada any errors, discrepancies, or omissions the Contractor may discover when reviewing the contract documents. In making a review, the Contractor does not assume any responsibility to Canada for the accuracy of the review. The Contractor shall not be liable for damage or costs resulting from such errors, discrepancies, or omissions in the contract documents prepared by or on behalf of Canada that the Contractor did not discover.

GC3.3 CONSTRUCTION SAFETY

- 1) The Contractor shall be solely responsible for construction safety at the place of the Work and for initiating, maintaining and supervising all safety precautions and programs in connection with the performance of the Work. In any emergency, the Contractor shall either stop the Work, make changes or order extra work to ensure the safety of life and the protection of the Work and neighbouring property.
- 2) Prior to commencing the Work, the Contractor shall notify the authorities having jurisdiction for construction safety at the site of the Work with respect to the intended commencement of the Work, and shall provide such authority with whatever additional information may be required by that authority.
- 3) The Contractor shall not load nor permit to be loaded any part of the Work or its site with a weight or force that shall endanger the safety of the Work.
- 4) The Contractor hereby represents and warrants to *Canada* that appropriate health and safety instruction and training have been provided and will be provided to the Contractor's employees and sub-contractors, and if requested by *Canada*, the Contractor shall provide proof of the same satisfactory to *Canada* prior to commencing the Work.
- 5) If required by the Occupational Health and Safety Acts and Regulations of the province or territory where the Work is to be undertaken, the Contractor shall establish and maintain a joint health and safety committee and / or trades health and safety committee for the Work.
- 6) The Contractor's site supervisor shall perform a health and safety inspection of all parts of the Work site every day and shall record his / her observations using a form acceptable to *Canada* or its representative, and shall provide a copy of the completed inspection form to *Canada* or its representative forthwith upon completion of the inspection.
- 7) The Contractor shall advise *Canada* or its representative forthwith of any accident, injury, near-miss incident, fire, explosion or chemical spill occurring at the Work site, and of any visit to the site by a governmental enforcement official.
- 8) The Contractor shall document any identified instances of non-compliance with safety requirements by its workers and subcontractors. Where any worker or subcontractor breaches LIFE THREATENING SAFETY REQUIREMENTS and thereby presents a threat of serious injury or death to any person, the Contractor shall remove that worker or subcontractor from the project site for the duration of the project. Where any worker or subcontractor breaches any SAFETY REQUIREMENT, a total of three (3) times, then the Contractor shall remove that worker or subcontractor from the project site for the duration of the project. The Contractor shall establish requirement for compliance, and this expulsion penalty for non-compliance, as a term of any agreement between the Contractor and its sub-contractors. The Contractor shall indemnify and save harmless

7 SECTION 7
CONTRACT DOCUMENTS – Appendix “C” General Conditions (GC)

Canada in respect of any claims made by any party against *Canada* in consequence of the Contractor's enforcement of site safety requirements, and removal from the site of any party.

- 9) The Contractor shall familiarize itself with, and ensure that its personnel comply with, the requirements of *Canada's* standards, rules, policies and procedures, if any, that are applicable to the Work site and the Place of Work.
- 10) The Contractor shall ensure that the Contractor's workers, subcontractors and any other persons permitted access to the Place of Work by the Contractor or *Canada* have and use, and are provided with instruction in the use of, any and all of the following protective equipment, devices and clothing, as warranted in the circumstances: safety hard hats, eye protection, face protection, hearing protection, impervious disposal coveralls, impervious shoe covers.
- 11) The Contractor shall make available and supply for use by visitors to the site, at no cost, the following types of personal protective equipment, as warranted in the circumstances: safety hard hats, eye protection, face protection, hearing protection, respiratory protection, impervious disposal coveralls, impervious shoe covers.
- 12) The Contractor shall ensure that the Contractor's workers, subcontractors and any other persons permitted access to the Place of Work by the Contractor or *Canada* are informed of every known or foreseeable health and safety hazard to which they are likely to be exposed at the Place of Work.

GC3.4 EXECUTION OF THE WORK

- 1) The Contractor shall perform, use or supply and pay for, all labour, Plant, Material, tools, construction machinery and equipment, water, heat, light, power, transportation, and other facilities and services necessary for the performance of the Work in accordance with the Contract.
- 2) The Contractor shall, at all times, perform the Work in a proper, diligent and expeditious manner as is consistent with construction industry standards and in accordance with the progress schedule prepared pursuant to GC3.1 PROGRESS SCHEDULE, and shall provide sufficient personnel to fulfil the Contractor's obligations in accordance with that schedule.
- 3) Subject to paragraph 4) of GC3.4, the Contractor shall have complete care, custody and control of the Work and shall direct and supervise the Work so as to ensure compliance with the Contract. The Contractor shall be responsible for construction means, methods, techniques, sequences and procedures and for co-ordinating the various parts of the Work.
- 4) When requested in writing by *Canada*, the Contractor shall make appropriate alterations in the method, Plant or workforce at any time *Canada* considers the Contractor's actions to be unsafe or damaging to either the Work, existing facilities, persons at the site of the Work or the environment.
- 5) The Contractor shall have sole responsibility for the design, erection, operation, maintenance and removal of temporary structures and other temporary facilities and for the construction methods used in their erection, operation, maintenance and removal. The Contractor shall engage and pay for registered professional engineering personnel, skilled in the appropriate discipline to perform these functions if required by law or by the Contract, and in all cases when such temporary facilities and their methods of construction are of such a nature that professional engineering skill is required to produce safe and satisfactory results.
- 6) The Contractor shall keep at least one copy of current contract documents, submittals, reports, and records of meetings at the site of the Work, in good order and available to *Canada*.
- 7) Except for any part of the Work that is necessarily performed away from or off the site of the Work, the Contractor shall confine Plant, storage of Material, and operations of employees to limits indicated by laws, ordinances, permits or the contract documents.

GC3.5 MATERIAL

7 SECTION 7
CONTRACT DOCUMENTS – Appendix “C” General Conditions (GC)

- 1) Unless otherwise specified in the Contract, all Material incorporated in the Work shall be new.
- 2) Subject to paragraph 3) of GC3.5, if a specified reused, refurbished, or recycled item of Material is not available, the Contractor shall apply to Canada to substitute a similar item for the one specified.
- 3) If Canada agrees that the Contractor's application for substitution of a reused, refurbished or recycled item is warranted, and that the substitute item is of acceptable quality and value to that specified and is suitable for the intended purpose, Canada may approve the substitution, subject to the following:
 - (a) the request for substitution shall be made in writing to Canada and shall be substantiated by information in the form of the manufacturer's literature, samples and other data that may be required by Canada;
 - (b) the Contractor shall make the request for substitution in a manner that shall not negatively affect the progress schedule of the Contract and well in advance of the time the item of Material must be ordered;
 - (c) substitution of Material shall be permitted only with the prior written approval of Canada, and any substituted items that are supplied or installed without such approval shall be removed from the site of the Work at the expense of the Contractor, and specified items installed at no additional cost to Canada; and
 - (d) the Contractor shall be responsible for all additional expenses incurred by Canada, the Contractor, its subcontractors and suppliers at any tier due to the Contractor's use of the substitute.

GC3.6 SUBCONTRACTING

- 1) Subject to the provisions of this clause, the Contractor may subcontract any part of the Work but not the whole of the Work.
- 2) The Contractor shall notify Canada in writing of the Contractor's intention to subcontract.
- 3) A notification referred to in paragraph 2) of GC3.6 shall identify the part of the Work and the Subcontractor with whom the Contractor intends to subcontract.
- 4) Canada may for reasonable cause, object to the intended subcontracting by notifying the Contractor in writing within six (6) days of receipt by Canada of a notification referred to in paragraph 2) of GC3.6.
- 5) If Canada objects to a subcontracting, the Contractor shall not enter into the intended subcontract.
- 6) The Contractor shall not change, nor permit to be changed, a Subcontractor engaged by the Contractor, in accordance with this clause, without the written consent of Canada.
- 7) The Contractor shall ensure that all the terms and conditions of the Contract that are of general application shall be incorporated in every other contract issued as a consequence of the Contract, at whatever tier, except those contracts issued solely to suppliers at any tier for the supply of Plant or Material.
- 8) Neither a subcontracting nor Canada's consent to a subcontracting shall be construed to relieve the Contractor from any obligation under the Contract or to impose any liability upon Canada.

GC3.7 CONSTRUCTION BY OTHER CONTRACTORS OR WORKERS

- 1) Canada reserves the right to send other contractors or workers, with or without Plant and Material, onto the site of the Work.
- 2) When other contractors or workers are sent on to the site of the Work, Canada shall
 - (a) enter into separate contracts, to the extent it is possible, with the other contractors under conditions of contract that are compatible with the conditions of the Contract;

7 SECTION 7
CONTRACT DOCUMENTS – Appendix “C” General Conditions (GC)

- (b) ensure that the insurance coverage provided by the other contractors is co-ordinated with the insurance coverage of the Contractor as it affects the Work; and
 - (c) take all reasonable precautions to avoid labour disputes or other disputes arising from the work of the other contractors or workers.
- 3) When other contractors or workers are sent on to the site of the Work, the Contractor shall
- (a) co-operate with them in the carrying out of their duties and obligations;
 - (b) co-ordinate and schedule the Work with the work of the other contractors and workers;
 - (c) participate with other contractors and workers in reviewing their construction schedules when directed to do so; and
 - (d) where part of the Work is affected by or depends upon the work of other contractors or workers for its proper execution, promptly report to Canada in writing and prior to proceeding with that part of the Work, any apparent deficiencies in such work. Failure by the Contractor to so report shall invalidate any claims against Canada by reason of the deficiencies in the work of other contractors or workers except those deficiencies that are not then reasonably discoverable.
 - (e) when designated as the constructor in accordance with the applicable provincial or territorial laws, carry out its duties in that role and in accordance with those laws.
- 4) If, when entering into the Contract, the Contractor could not have reasonably foreseen nor anticipated the sending of other contractors or workers on to the site of the Work and provided the Contractor
- (a) incurs extra expense in complying with the requirements of paragraph 3) of GC3.7; and
 - (b) gives Canada written notice of a claim for that extra expense within thirty (30) days of the date that the other contractors or workers were sent onto the Work or its site;
Canada pay the Contractor the cost of the extra labour, Plant and Material that was necessarily incurred, calculated in accordance with GC6.4 DETERMINATION OF PRICE.

GC3.8 LABOUR AND FAIR WAGES

- 1) The Labour Conditions and Fair Wage Schedule form part of these General Conditions
- 2) To the extent to which they are available, consistent with proper economy and the expeditious carrying out of the Work, the Contractor shall, in the performance of the Work, employ a reasonable number of persons who have been on active service with the Armed Forces of Canada and have been honourably discharged therefrom.
- 3) The Contractor shall maintain good order and discipline among the Contractor's employees and workers engaged in the Work and shall not employ on the site of the Work anyone not skilled in the tasks assigned.

GC3.9 MATERIAL, PLANT AND REAL PROPERTY BECOME PROPERTY OF CANADA

- 1) Subject to paragraph 9) of GC1.8 LAWS PERMITS AND TAXES, all Material and Plant and the interest of the Contractor in all real property, licences, powers and privileges purchased, used or consumed by the Contractor for the Work shall, immediately after the time of their purchase, use or consumption be the property of Canada for the purposes of the Work and they shall continue to be the property of Canada
 - (a) in the case of Material, until Canada indicates that the Materials shall not be required for the Work; and
 - (b) in the case of Plant, real property, licences, powers and privileges, until Canada indicates that the interest vested in Canada therein is no longer required for the purposes of the Work.

7 SECTION 7
CONTRACT DOCUMENTS – Appendix “C” General Conditions (GC)

- 2) Material or Plant, that is the property of Canada by virtue of paragraph 1) of GC3.9, shall not be taken away from the site of the Work nor used nor disposed of except for the purposes of the Work without the written consent of Canada.
- 3) Canada is not liable for loss of nor damage from any cause to the Material or Plant referred to in paragraph 1) of GC3.9, and the Contractor is liable for such loss or damage notwithstanding that the Material or Plant is the property of Canada.

GC3.10 DEFECTIVE WORK

- 1) The Contractor shall promptly remove from the site of the Work and replace or re-execute defective Work whether or not the defective Work has been incorporated in the Work and whether or not the defect is the result of poor workmanship, use of defective Material, or damage through carelessness or other act or omission of the Contractor.
- 2) The Contractor, at the Contractor's expense, shall promptly make good other work destroyed or damaged by such removals or replacements.
- 3) If, in the opinion of Canada, it is not expedient to correct defective Work or Work not performed as provided for in the Contract documents, Canada may deduct from the amount otherwise due to the Contractor the difference in value between the Work as performed and that called for by the contract documents.
- 4) The failure of Canada to reject any defective Work or Material shall not constitute acceptance of the defective Work or Material.

GC3.11 CLEANUP OF SITE

- 1) The Contractor shall maintain the Work and its site in a tidy condition and free from an accumulation of waste material and debris.
- 2) Before the issue of a Certificate of Substantial Performance, the Contractor shall remove waste material and debris, and all Plant and Material not required for the performance of the remaining Work and, unless otherwise stipulated in the Contract Documents, shall cause the Work and its site to be clean and suitable for occupancy by Canada.
- 3) Before the issue of a Certificate of Completion, the Contractor shall remove all surplus Plant and Materials and any waste products and debris from the site of the Work.
- 4) The Contractor's obligations described in paragraphs 1) to 3) of GC3.11 do not extend to waste products and other debris caused by Canada's servants, or by other contractors and workers referred to in GC3.7 CONSTRUCTION BY OTHER CONTRACTORS OR WORKERS.

GC3.12 WARRANTY AND RECTIFICATION OF DEFECTS IN WORK

- 1) Without restricting any warranty or guarantee implied or imposed by law or contained in the Contract, the Contractor shall, at the Contractor's expense
 - (a) rectify and make good any defect or fault that appears in the Work or comes to the attention of Canada with respect to those parts of the Work accepted in connection with the Certificate of Substantial Performance within 12 months from the date of Substantial Performance; and
 - (b) rectify and make good any defect or fault that appears in or comes to the attention of Canada in connection with those parts of the Work described in the Certificate of Substantial Performance within 12 months from the date of the Certificate of Completion.
 - (c) transfer and assign, to Canada, any subcontractor, manufacturer or supplier extended warranties or guarantees implied or imposed by law or contained in the Contract covering periods beyond the 12 months stipulated above. Extended warranties or guarantees referred to herein shall not extend the 12-

7 SECTION 7
CONTRACT DOCUMENTS – Appendix “C” General Conditions (GC)

month period whereby the Contractor, except as may be provided elsewhere in the Contract, must rectify and make good any defect or fault that appears in the Work or comes to the attention of Canada.

- (d) provide, to Canada prior to the issuance of the Certificate of Completion, a list of all extended warranties and guarantees referred to in paragraph (c) above.
- 2) Canada may direct the Contractor to rectify and make good any defect or fault referred to in paragraph 1) of GC3.12 or covered by any other expressed or implied warranty or guarantee and the Contractor shall rectify and make good such defect within the time stipulated in the direction.
- 3) A direction referred to in paragraph 2) GC3.12 shall be in writing and shall be given to the Contractor in accordance with GC2.3 NOTICES.

GC4 PROTECTIVE MEASURES

GC4.1 PROTECTION OF WORK AND PROPERTY

- 1) The Contractor shall protect the Work and its site against loss or damage from any cause and shall similarly protect all Material, Plant and real property under the Contractor's care, custody and control whether or not such Material, Plant and real property are supplied by Canada to the Contractor.
- 2) The Contractor shall provide all facilities necessary for the purpose of maintaining security, and shall assist any person authorized by Canada to inspect or to take security measures in respect of the Work and its site.
- 3) Canada may direct the Contractor to do such things and to perform such work as Canada considers reasonable and necessary to ensure compliance with or to remedy a breach of paragraphs 1) or 2) of GC4.1, and the Contractor, shall comply with such direction.

GC4.2 PRECAUTIONS AGAINST DAMAGE, INFRINGEMENT OF RIGHTS, FIRE AND OTHER HAZARDS

- 1) The Contractor shall do whatever is necessary to ensure that
 - (a) no person, property, right, easement nor privilege is injured, damaged or infringed upon by reasons of the Contractor's activities in performing the Work;
 - (b) pedestrian and other traffic on any public or private road or waterway is not unduly impeded, interrupted nor endangered by the performance or existence of the Work, Material or Plant;
 - (c) fire hazards in or about the site of the Work are eliminated and any fire is promptly extinguished;
 - (d) the health and safety of all persons employed in the performance of the Work is not endangered by the methods nor means of its performance;
 - (e) adequate medical services are available to all persons employed on the Work or its site at all times during the performance of the Work;
 - (f) adequate sanitation measures are taken in respect of the Work and its site; and
 - (g) all stakes, buoys and marks placed on the Work or its site by Canada are protected and are not removed, defaced, altered nor destroyed.
- 2) Canada may direct the Contractor to do such things and to perform such work as Canada considers reasonable and necessary to ensure compliance with or to remedy a breach of paragraph 1) of GC4.2, and the Contractor shall comply with the direction of Canada.

GC4.3 MATERIAL, PLANT AND REAL PROPERTY SUPPLIED BY CANADA

7 SECTION 7
CONTRACT DOCUMENTS – Appendix “C” General Conditions (GC)

- 1) Subject to paragraph 2) of GC4.3, the Contractor is liable to Canada for any loss of or damage to Material, Plant or real property that is supplied or placed in the care, custody and control of the Contractor by Canada for use in connection with the Contract, whether or not that loss or damage is attributable to causes beyond the Contractor's control.
- 2) The Contractor is not liable to Canada for any loss or damage to Material, Plant or real property referred to in paragraph 1) of GC4.3 if that loss or damage results from and is directly attributable to reasonable wear and tear.
- 3) The Contractor shall not use any Material, Plant or real property supplied by Canada except for the purpose of performing the Contract.
- 4) When the Contractor fails to make good any loss or damage for which the Contractor is liable under paragraph 1) within a reasonable time, Canada may cause the loss or damage to be made good at the Contractor's expense, and the Contractor shall thereupon be liable to Canada for the cost thereof and shall, on demand, pay to Canada an amount equal to that cost.
- 5) The Contractor shall keep records of all Material, Plant and real property supplied by Canada as Canada requires and shall satisfy Canada, when requested, that such Material, Plant and real property are at the place and in the condition in which they ought to be.

GC4.4 CONTAMINATED SITE CONDITIONS

- 1) For the purposes of GC4.4, a contaminated site condition exists when a solid, liquid, gaseous, thermal or radioactive irritant or contaminant, or other hazardous or toxic substance or material, including moulds and other forms of fungi, is present at the site of the Work to an extent that constitutes a hazard, or potential hazard, to the environment, property, or the health or safety of any person.
- 2) If the Contractor encounters a contaminated site condition of which the Contractor is not aware or about which the Contractor has not been advised, or if the Contractor has reasonable grounds to believe that such a site condition exists at the site of the Work, the Contractor shall
 - (a) take all reasonable steps, including stopping the Work, to ensure that no person suffers injury, sickness or death, and that neither property nor the environment is injured or destroyed as a result of the contaminated site condition;
 - (b) immediately notify Canada of the circumstances in writing; and
 - (c) take all reasonable steps to minimize additional costs that may accrue as a result of any work stoppage.
- 3) Upon receipt of a notification from the Contractor, Canada shall promptly determine whether a contaminated site condition exists, and shall notify the Contractor in writing of any action to be taken, or work to be performed, by the Contractor as a result of Canada's determination.
- 4) If the Contractor's services are required by Canada, the Contractor shall follow the direction of Canada with regard to any excavation, treatment, removal and disposal of any polluting substance or material.
- 5) Canada, at Canada's sole discretion, may enlist the services of experts and specialty contractors to assist in determining the existence of, and the extent and treatment of contaminated site conditions, and the Contractor shall allow them access and co-operate with them in the carrying out of their duties and obligations.
- 6) Except as may be otherwise provided for in the Contract, the provisions of GC6.4 DETERMINATION OF PRICE shall apply to any additional work made necessary because of a contaminated site condition.

GC5 TERMS OF PAYMENT

GC5.1 INTERPRETATION

In these Terms of Payment

- 1) The "payment period" means a period of 30 consecutive days or such other longer period as may be agreed between the Contractor and Canada.
- 2) An amount is "due and payable" when it is due and payable by Canada to the Contractor according to GC5.4 PROGRESS PAYMENT, GC5.5 SUBSTANTIAL PERFORMANCE OF THE WORK or GC5.6 FINAL COMPLETION.
- 3) An amount is overdue when it remains unpaid on the first day following the day upon which it is due and payable.
- 4) The "date of payment" means the date of the negotiable instrument of an amount due and payable by the Receiver General for Canada.
- 5) The "Bank Rate" means the rate of interest established by the Bank of Canada as the minimum rate at which it makes short term advances to members of the Canadian Payments Association.
- 6) The "Average Bank Rate" means the simple arithmetic mean of the Bank Rate in effect at 4:00 p.m. Eastern Standard Time each day during the calendar month which immediately precedes the calendar month in which payment is made.

GC5.2 AMOUNT PAYABLE

- 1) Subject to any other provisions of the Contract, Canada shall pay the Contractor, at the times and in the manner hereinafter set out, the amount by which the amounts payable by Canada to the Contractor in accordance with the Contract exceed the amounts payable by the Contractor to Canada, and the Contractor shall accept that amount as payment in full satisfaction for everything furnished and done by the Contractor in respect of the Work to which the payment relates.
- 2) When making any payment to the Contractor, the failure of Canada to deduct an amount payable to Canada by the Contractor shall not constitute a waiver of the right to do so, or an admission of lack of entitlement to do so in any subsequent payment to the Contractor.
- 3) No payment other than a payment that is expressly stipulated in the Contract, shall be made by Canada to the Contractor for any extra expense or any loss or damage incurred or sustained by the Contractor.

GC5.3 INCREASED OR DECREASED COSTS

- 1) The Contract Amount shall not be increased nor decreased by reason of any increase or decrease in the cost of the Work that is brought about by an increase or decrease in the cost of labour, Plant, Material or any wage adjustment arising pursuant to the Labour Conditions.
- 2) Notwithstanding paragraph 1) of GC5.3, if any change, including a new imposition or repeal, of any tax, customs or other duty, charge, or any similar imposition that is imposed under sales, customs or excise tax legislation of the Government of Canada or any Provincial or Territorial legislation, affects the cost of the Work to the Contractor, and occurs

(a) after the date of submission by the Contractor of its tender; or

(b) after the date of submission of the last revision, if the Contractor's tender was revised;

the Contract Amount shall be adjusted in the manner provided in paragraph 3) of GC5.3.

7 SECTION 7
CONTRACT DOCUMENTS – Appendix “C” General Conditions (GC)

- 3) If a change referred to in paragraph 2) of GC5.3 occurs, the Contract Amount shall be increased or decreased by an amount established by an examination by Canada of the relevant records of the Contractor referred to in GC2.8 ACCOUNTS AND AUDITS to be the increase or decrease in the cost incurred by the Contractor that is directly attributable to that change.
- 4) For the purpose of paragraph 2) of GC5.3, if a tax is changed after the tender closing, but public notice of the change has been given by the Minister of Finance or the corresponding Provincial or Territorial authority before that closing, the change shall be deemed to have occurred before the tender closing.
- 5) Notwithstanding paragraphs 2) to 4) of GC5.3, no adjustment to the Contract Amount in respect of the Work or a part thereof shall be made for a change in any imposition referred to in this section that occurs after the date required by the Contract for completion of the Work or that part of the Work.

GC5.4 PROGRESS PAYMENT

- 1) On the expiration of a payment period, the Contractor shall deliver to Canada
 - (a) a written progress claim in a form acceptable to Canada that fully describes any part of the Work that has been completed, and any Material that was delivered to the Work site but not incorporated into the Work, during that payment period, and
 - (b) a completed and signed statutory declaration containing a declaration that, up to the date of the progress claim, the Contractor has complied with all lawful obligations with respect to the Labour Conditions and that, in respect of the Work, all lawful obligations of the Contractor to its Subcontractors and Suppliers, referred to collectively in the declaration as “subcontractors and suppliers”, have been fully discharged.
- 2) Within 10 days of receipt of a progress claim and statutory declaration from the Contractor, Canada shall inspect, or cause to have inspected, the part of the Work and the Material described in the progress claim, and shall issue a progress report to the Contractor, that indicates the value of the part of the Work and the Material described in the progress claim that, in the opinion of Canada
 - (a) is in accordance with the Contract; and
 - (b) was not included in any other progress report relating to the Contract.
- 3) Subject to GC5.2 AMOUNT PAYABLE, and paragraph 5) of GC5.4, Canada shall pay the Contractor an amount that is equal to
 - (a) 95% of the value that is indicated in Canada's progress report if a labour and material payment bond has been furnished by the Contractor; or
 - (b) 90% of the value that is indicated in Canada's progress report if a labour and material payment bond has not been furnished by the Contractor.
- 4) Canada shall pay the amount referred to in paragraph 3) of GC5.4 not later than
 - (a) 30 days after receipt by Canada of both a progress claim and a statutory declaration referred to in paragraph 1) of GC5.4; or
 - (b) 15 days after receipt by Canada of the Contractor's progress schedule or updated progress schedule, in accordance with GC3.1 PROGRESS SCHEDULE,whichever is later.
- 5) In the case of the Contractor's first progress claim, it is a condition precedent to Canada's obligation under paragraph 3) of GC5.4 that the Contractor has provided all necessary documentation required by the Contract

7 SECTION 7
CONTRACT DOCUMENTS – Appendix “C” General Conditions (GC)

for the first progress claim and has provided evidence of compliance with workers' compensation legislation applicable to the place of the Work in accordance with GC1.9 WORKERS' COMPENSATION.

GC5.5 SUBSTANTIAL PERFORMANCE OF THE WORK

- 1) If, at any time before the issuance of a Certificate of Completion, Canada determines that the Work has reached Substantial Performance as described in subparagraph 1) (b) of GC1.1.4 SUBSTANTIAL PERFORMANCE, Canada shall issue a Certificate of Substantial Performance to the Contractor. The Certificate of Substantial Performance shall state or describe
 - (a) the date of Substantial Performance;
 - (b) the parts of the Work not completed to the satisfaction of Canada; and
 - (c) all things that must be done by the Contractor before a Certificate of Completion is issued and before the 12-month warranty period referred to in GC3.12 WARRANTY AND RECTIFICATION OF DEFECTS IN WORK commences for the said parts and all the said things.
- 2) The issuance of a Certificate of Substantial Performance does not relieve the Contractor from the Contractor's obligations under GC3.10 DEFECTIVE WORK.
- 3) Subject to GC5.2 AMOUNT PAYABLE and paragraph 4) of GC5.5, Canada shall pay the Contractor the amount referred to in paragraph 1) of GC5.2 AMOUNT PAYABLE, less the aggregate of
 - (a) the sum of all payments that were made pursuant to GC5.4 PROGRESS PAYMENT;
 - (b) an amount that is equal to Canada's estimate of the cost to Canada of rectifying defects described in the Certificate of Substantial Performance; and
 - (c) an amount that is equal to Canada's estimate of the cost to Canada of completing the parts of the Work described in the Certificate of Substantial Performance other than defects listed therein.
- 4) Canada shall pay the amount referred to in paragraph 3) of GC5.5 not later than
 - (a) 30 days after the date of issue of a Certificate of Substantial Performance, or
 - (b) 15 days after the Contractor has delivered to Canada
 - (i) a statutory declaration containing a declaration by the Contractor that up to the date of the Certificate of Substantial Performance, the Contractor has complied with all lawful obligations with respect to the Labour Conditions, discharged all its lawful obligations to its Subcontractors and Suppliers in respect of the work under the Contract, and discharged its lawful obligations referred to in GC1.8 LAWS, PERMITS AND TAXES;
 - (ii) evidence of compliance with workers' compensation legislation in accordance with GC1.9 WORKERS' COMPENSATION; and
 - (iii) an update of the progress schedule in accordance with the requirements of GC3.1 PROGRESS SCHEDULE;

whichever is later.

7 SECTION 7
CONTRACT DOCUMENTS – Appendix “C” General Conditions (GC)

GC5.6 FINAL COMPLETION

- 1) When Canada is of the opinion that the Contractor has complied with the Contract and all orders and directions made pursuant thereto, and that the Work has been completed as described in GC1.1.5 COMPLETION, Canada shall issue a Certificate of Completion to the Contractor and, if the Work or a portion of the Work is subject to a Unit Price Arrangement, Canada shall issue a Certificate of Measurement that shall, subject to GC 8, be binding upon and conclusive between Canada and the Contractor as to the quantities referred to therein.
- 2) Subject to GC5.2 AMOUNT PAYABLE and paragraph 3) of GC5.6, Canada shall pay the Contractor the amount referred to in GC5.2 AMOUNT PAYABLE, less the aggregate of the sum of all payments that were made pursuant to GC5.4 PROGRESS PAYMENT and GC5.5 SUBSTANTIAL PERFORMANCE OF WORK.
- 3) Canada shall pay the amount referred to in paragraph 2) of GC5.6 not later than
 - (a) 60 days after the date of issue of a Certificate of Completion; or
 - (b) 15 days after the Contractor has delivered to Canada
 - (i) a statutory declaration which contains a declaration by the Contractor that all of the Contractor's lawful obligations and any lawful claims against the Contractor that arose out of the performance of the Contract have been discharged and satisfied; and
 - (ii) evidence of compliance with workers' compensation legislation in accordance with GC1.9 WORKERS' COMPENSATION;
whichever is later.

GC5.7 PAYMENT NOT BINDING ON CANADA

- 1) Neither acceptance of a progress claim or progress report, nor any payment made by Canada under the Contract, nor partial or entire use or occupancy of the Work by Canada shall constitute an acceptance by Canada of any portion of the Work or Material that is not in accordance with the requirements of the Contract.

GC5.8 CLAIMS AND OBLIGATIONS

- 1) The Contractor shall discharge all the Contractor's lawful obligations and shall satisfy all lawful claims against the Contractor arising out of the performance of the Work at least as often as the Contract requires Canada to pay the Contractor.
- 2) Whenever requested to do so by Canada, the Contractor shall make a statutory declaration declaring to the existence and condition of any obligations and claims against the Contractor arising out of the performance of the Work.
- 3) In order to discharge lawful obligations of and satisfy lawful claims against the Contractor or its Subcontractors arising out of the performance of the Contract, Canada may pay an amount that is due and payable to the Contractor directly to the claimant. Such payment is, to the extent of the payment, a discharge of Canada's liability to the Contractor under the Contract and may be deducted from any amount payable to the Contractor under the Contract.
- 4) For the purposes of paragraph 3) of GC5.8, and subject to paragraph 6) of GC5.8, a claim or obligation shall be considered lawful when it is so determined by
 - (a) a court of legal jurisdiction;
 - (b) an arbitrator duly appointed to arbitrate the claim; or
 - (c) the written consent of the Contractor authorizing payment of the claim or obligation.

7 SECTION 7
CONTRACT DOCUMENTS – Appendix “C” General Conditions (GC)

- 5) If a claim or obligation would have been subject to the provisions of Provincial or Territorial lien legislation or, in the Province of Quebec, the law relating to legal hypothecs had the Contractor been performing the Work for an entity other than Canada
- (a) such amount as may be paid by Canada pursuant to paragraphs 3) and 4) of GC5.8 shall not exceed the amount that the Contractor would have been obliged to pay had the provisions of such legislation or law been applicable to the Work;
 - (b) a claimant need not comply with the provisions of such legislation, setting out the steps by way of notice, registration or otherwise as might have been necessary to preserve or perfect any claim for lien or privilege which the claimant might have had; and
 - (c) for the purposes of determining the entitlement of a claimant, the notice required by paragraph 8) of GC5.8 shall be deemed to replace the registration or provision of notice after the performance of work as required by any applicable legislation and no claim shall be deemed to have expired, become void or unenforceable by reason of the claimant not commencing any action within the time prescribed by such legislation.
- 6) The Contractor shall, at the request of any claimant, submit to binding arbitration those questions that need to be answered to establish the entitlement of the claimant to payment. The arbitration shall have as parties to it any Subcontractor or Supplier to whom the claimant supplied Material, performed work or rented equipment should such Subcontractor or Supplier wish to be adjoined, and Canada shall not be a party to such arbitration. Subject to any agreement between the Contractor and the claimant, the arbitration shall be conducted in accordance with the governing Provincial or Territorial legislation applicable to the site of the Work.
- 7) Paragraph 3) of GC5.8 shall apply only to claims and obligations
- (a) the notification of which has set forth the amount claimed to be owing and the person who by contract is primarily liable and has been received by Canada in writing before final payment is made to the Contractor pursuant to GC5.6 FINAL COMPLETION, and within 120 days of the date on which the claimant
 - (i) should have been paid in full under the claimant's contract with the Contractor, its Subcontractor or Supplier if the claim is for money that was lawfully required to be held back from the claimant; or
 - (ii) performed the last of the services, work or labour, or furnished the last of the Material pursuant to the claimant's contract with the Contractor or its Subcontractor or Supplier where the claim is for money not lawfully required to be held back from the claimant; and
 - (b) the proceedings to determine the right to payment of which, pursuant to paragraph 5) of GC5.8, shall have commenced within one year from the date that the notification required by subparagraph 7)(a) of GC5.8 was received by Canada.
- 8) Upon receipt of a notice of claim, Canada may withhold, from any amount that is due and payable to the Contractor pursuant to the Contract, the full amount of the claim or any portion thereof.
- 9) Canada shall notify the Contractor in writing in a timely manner of receipt of any claim and of the intention of Canada to withhold funds. At any time thereafter and until payment is made to the claimant, the Contractor may be entitled to post, with Canada, security in a form acceptable to Canada in an amount equal to the value of the claim, and upon receipt of such security Canada shall release to the Contractor any funds that would be otherwise payable to the Contractor, that were withheld pursuant to the provisions of this clause in respect of the claim of any claimant for whom the security stands.

7 SECTION 7
CONTRACT DOCUMENTS – Appendix “C” General Conditions (GC)

GC5.9 RIGHT OF SETOFF

- 1) Without limiting any right of setoff or deduction given or implied by law or elsewhere in the Contract, Canada may set off any amount payable to Canada by the Contractor under the Contract, or under any current contract, against any amount payable to the Contractor under the Contract.
- 2) For the purposes of paragraph 1) of GC5.9, "current contract" means a contract between Canada and the Contractor
 - (a) under which the Contractor has an undischarged obligation to perform or supply work, labour or material; or
 - (b) in respect of which Canada has, since the date of the Contract, exercised any right to take the work that is the subject of that contract out of the Contractor's hands.

GC5.10 ASSESSMENTS AND DAMAGES FOR LATE COMPLETION

- 1) For the purposes of this clause
 - (a) the Work shall be deemed to be completed on the date of the Certificate of Completion; and
 - (b) the "period of delay" means the number of days commencing on the day fixed for completion of the Work and ending on the day immediately preceding the day on which the Work is completed but does not include any day within a period of extension granted pursuant to GC6.5 DELAYS AND EXTENSION OF TIME and any other day on which, in the opinion of Canada, completion of the Work was delayed for reasons beyond the control of the Contractor.
- 2) If the Contractor does not complete the Work by the day fixed for its completion but completes it thereafter, the Contractor shall pay Canada an amount equal to the aggregate of
 - (a) all salaries, wages and travelling expenses incurred by Canada in respect of persons overseeing the performance of the Work during the period of delay;
 - (b) the cost incurred by Canada as a result of the inability to use the completed Work for the period of delay; and
 - (c) all other expenses and damages incurred or sustained by Canada during the period of delay as a result of the Work not being completed by the day fixed for its completion.
- 3) Canada may waive the right of Canada to the whole or any part of the amount payable by the Contractor pursuant to paragraph 2) of GC5.10 if, in the opinion of Canada, it is in the public interest to do so.

GC5.11 DELAY IN MAKING PAYMENT

- 1) Notwithstanding GC1.5 TIME OF THE ESSENCE, any delay by Canada in making any payment when it is due pursuant to GC5 TERMS OF PAYMENT, shall not be a breach of the Contract by Canada.
- 2) Subject to paragraph 3) of GC5.11, Canada shall pay to the Contractor simple interest at the Average Bank Rate plus 3 percent per annum on any amount that is overdue pursuant to paragraph 3) of GC5.1 INTERPRETATION, and the interest shall apply from and include the day such amount became overdue until the day prior to the date of payment.
- 3) Interest shall be paid without demand by the Contractor except that
 - (a) in respect of amounts that are less than 15 days overdue, no interest shall be paid in respect of payment made within such 15 days unless the Contractor so demands after such amounts have become due and payable; and
 - (b) interest shall not be payable or paid on overdue advance payments, if any.

7 SECTION 7
CONTRACT DOCUMENTS – Appendix “C” General Conditions (GC)

GC5.12 INTEREST ON SETTLED CLAIMS

- 1) For the purposes of this clause, a claim means a disputed amount subject to negotiation between Canada and the Contractor under the Contract.
- 2) A claim is deemed to have been settled when an agreement in writing is signed by Canada and the Contractor setting out the amount of the claim to be paid by Canada and the items of work for which the said amount is to be paid.
- 3) A settled claim is deemed to be outstanding from the day immediately following the date the said claim would have been due and payable under the Contract had it not been disputed.
- 4) Canada shall pay to the Contractor simple interest on the amount of a settled claim at the Average Bank Rate plus 3 per cent per annum from the date the settled claim was deemed to be outstanding until the day prior to the date of payment.

GC5.13 RETURN OF SECURITY DEPOSIT

- 1) After a Certificate of Substantial Performance has been issued, and if the Contractor is not in breach of nor in default under the Contract, Canada shall return to the Contractor all or any part of a Security Deposit that, in the opinion of Canada, is not required for the purposes of the Contract.
- 2) After a Certificate of Completion has been issued, Canada shall return to the Contractor the remainder of any security deposit unless the Contract stipulates otherwise.
- 3) If the security deposit was paid into the Consolidated Revenue Fund of Canada, Canada shall pay interest thereon to the Contractor at a rate established pursuant to section 21(2) of the Financial Administration Act.

GC6 DELAYS AND CHANGES IN THE WORK

GC6.1 CHANGES IN THE WORK

- 1) At any time before issuance of a Certificate of Completion, Canada may issue orders for additions, deletions or other changes to the Work, or changes in the location or position of the whole or any part of the Work, if the addition, deletion, change or other revision is deemed by Canada to be consistent with the general intent of the Contract.
- 2) An order referred to in paragraph 1) of GC6.1 shall be in writing and given to the Contractor in accordance with GC2.3 NOTICES.
- 3) Upon receipt of an order, the Contractor shall promptly perform the work in accordance with the order as if the order had appeared in and been part of the original Contract.
- 4) If anything done or omitted by the Contractor pursuant to an order increases or decreases the cost of the Work to the Contractor, payment for the work shall be made in accordance with GC6.4 DETERMINATION OF PRICE.

GC6.2 CHANGES IN SUBSURFACE CONDITIONS

- 1) If, during the performance of the Work, the Contractor encounters subsurface conditions that are substantially different from the subsurface conditions described in the tender documents supplied to the Contractor, or a reasonable assumption of fact based thereon, the Contractor shall give notice to Canada immediately upon becoming aware of the situation.
- 2) If the Contractor is of the opinion that the Contractor may incur or sustain any extra expense or any loss or damage that is directly attributable to the changed subsurface conditions, the Contractor shall within 10 days of the date the changed subsurface conditions were encountered, give Canada written notice of intention to claim for that extra expense, loss or damage.

7 SECTION 7
CONTRACT DOCUMENTS – Appendix “C” General Conditions (GC)

- 3) If the Contractor has given a notice referred to in paragraph 2) of GC6.2, the Contractor shall give Canada a written claim for extra expense, loss or damage no later than 30 days after the date that a Certificate of Substantial Performance is issued.
- 4) A written claim referred to in paragraph 3) of GC6.2 shall contain a sufficient description of the facts and circumstances of the occurrence that is the subject of the claim to enable Canada to determine whether or not the claim is justified, and the Contractor shall supply such further and other information for that purpose as Canada requires.
- 5) If Canada determines that a claim referred to in paragraph 3) of GC6.2 is justified, Canada shall make an extra payment to the Contractor in an amount that is calculated in accordance with GC6.4 DETERMINATION OF PRICE.
- 6) If, in the opinion of Canada, the Contractor effects a saving of expenditure that is directly attributable to a substantial difference between the information relating to subsurface conditions at the site of the Work that is contained in the tender documents, or a reasonable assumption of fact based thereon, and the actual subsurface conditions encountered by the Contractor, the Contract Amount shall be reduced by the amount of the saving of expenditure determined in accordance with GC6.4 DETERMINATION OF PRICE.
- 7) If the Contractor fails to give a notice referred to in paragraph 2) of GC6.2 and a claim referred to in paragraph 3) of GC6.2 within the times stipulated, an extra payment shall not be made to the Contractor in respect of the occurrence.
- 8) Canada does not warrant the content expressed in any subsurface report available for the perusal of the Contractor that does not form part of the tender and contract documents.

GC6.3 HUMAN REMAINS, ARCHAEOLOGICAL REMAINS AND ITEMS OF HISTORICAL OR SCIENTIFIC INTEREST

- 1) For the purposes of this clause
 - (a) "human remains" means the whole or any part of a deceased human being, irrespective of the time of death;
 - (b) "archaeological remains" are items, artefacts or things made, modified or used by human beings in antiquity and may include, but not be limited to, stone, wood or iron structures or monuments, dump deposits, bone artefacts, weapons, tools, coins, and pottery; and
 - (c) "items of historical or scientific interest" are naturally occurring or manufactured objects or things of any age that are not archaeological remains but may be of interest to society because of their historical or scientific significance, value, rarity, natural beauty, or other quality.
- 2) If, during the course of the Work, the Contractor encounters any object, item or thing which is described in paragraph 1) of GC6.3 or which resembles any object, item or thing described in paragraph 1) of GC6.3, the Contractor shall
 - (a) take all reasonable steps, including stopping work in the affected area, to protect and preserve the object, item or thing;
 - (b) immediately notify Canada of the circumstances in writing; and
 - (c) take all reasonable steps to minimize additional costs that may accrue as a result of any work stoppage.
- 3) Upon receipt of a notification in accordance with subparagraph 2)(b) of GC6.3, Canada shall promptly determine whether the object, item or thing is one described in, or contemplated by paragraph 1) of GC6.3, and shall notify the Contractor in writing of any action to be performed, or work to be carried out, by the Contractor as a result of Canada's determination.

7 SECTION 7
CONTRACT DOCUMENTS – Appendix “C” General Conditions (GC)

- 4) Canada may, at any time, enlist the services of experts to assist in the investigation, examination, taking of measurements or other such recordings, placing of permanent protection around or removing of the object, item or thing encountered by the Contractor, and the Contractor shall, to the satisfaction of Canada, allow them access and co-operate with them in the carrying out of their duties and obligations.
- 5) Human remains, archaeological remains and items of historical or scientific interest encountered at the site of the Work shall be deemed to be the property of Canada.
- 6) Except as may be otherwise provided for in the Contract, the provisions of GC6.4 DETERMINATION OF PRICE and GC6.5 DELAYS AND EXTENSION OF TIME shall apply.

GC6.4 DETERMINATION OF PRICE

GC6.4.1 Price Determination Prior to Undertaking Changes

- 1) If a Lump Sum Arrangement applies to the Contract or a part thereof, the price of any change shall be the aggregate estimated cost of labour, Plant and Material that is required for the change as agreed upon in writing by Canada plus a negotiated allowance for supervision, co-ordination, administration, overhead, margin and the risk of undertaking the work within the stipulated amount.
- 2) If a Unit Price Arrangement applies to the Contract or a part thereof, the Contractor and Canada may, by agreement in writing, add items, units of measurement, estimated quantities and prices per unit to the Unit Price Table.
- 3) A price per unit referred to in paragraph 2) of GC6.4.1 shall be determined on the basis of the aggregate estimated cost of labour, Plant and Material that is required for the additional item as agreed upon by the Contractor and Canada, plus a negotiated allowance.
- 4) To facilitate approval of the price of the change or the additional price per unit as applicable, the Contractor shall submit a cost estimate breakdown identifying, as a minimum, the estimated cost of labour, Plant, Material, each subcontract amount, and the amount of the negotiated allowance.
- 5) If no agreement is reached as contemplated in paragraph 1) of GC6.4.1, the price shall be determined in accordance with GC6.4.2.
- 6) If no agreement is reached, as contemplated in paragraphs 2) and 3) of GC6.4.1, Canada shall determine the class and the unit of measurement of the item of labour, Plant or Material and the price per unit shall be determined in accordance with GC6.4.2.

GC6.4.2 Price Determination Following Completion of Changes.

- 1) If it is not possible to predetermine, or if there is failure to agree upon the price of a change in the Work, the price of the change shall be equal to the aggregate of
 - (a) all reasonable and proper amounts actually expended or legally payable by the Contractor in respect of the labour, Plant and Material that fall within one of the classes of expenditure described in paragraph 2) of GC6.4.2, that are directly attributable to the performance of the Contract;
 - (b) an allowance for profit and all other expenditures or costs, including overhead, general administration costs, financing and interest charges, in an amount that is equal to 10% of the sum of the expenses referred to in subparagraph 1)(a) of GC6.4.2; and
 - (c) interest on the amounts determined under subparagraphs 1)(a) and 1)(b) of GC6.4.2 above calculated in accordance with GC5.12 INTEREST ON SETTLED CLAIMS;
- 2) The cost of labour, Plant and Material referred to in subparagraph 1)(a) of GC6.4.2 shall be limited to the following categories of expenditure:

7 SECTION 7
CONTRACT DOCUMENTS – Appendix “C” General Conditions (GC)

- (a) payments to Subcontractors and Suppliers;
- (b) wages, salaries, bonuses and, if applicable, travel and lodging expenses of employees of the Contractor located at the site of the Work and that portion of wages, salaries, bonuses and, if applicable, travel and lodging expenses of personnel of the Contractor generally employed at the head office or at a general office of the Contractor provided they are actually and properly engaged on the Work under the Contract;
- (c) assessments payable under any statutory authority relating to workers' compensation, employment insurance, pension plan or holidays with pay, provincial health or insurance plans, environmental reviews, and GST / HST collection costs;
- (d) rent that is paid for Plant, or an amount equivalent to the said rent if the Plant is owned by the Contractor, that is necessary for and used in the performance of the Work, if the rent or the equivalent amount is reasonable and use of that Plant has been approved by Canada;
- (e) payments for maintaining and operating Plant necessary for and used in the performance of the Work, and payments for effecting repairs thereto that, in the opinion of Canada, are necessary for the proper performance of the Contract, other than payments for any repairs to the Plant arising out of defects existing before its allocation to the Work;
- (f) payments for Material that is necessary for and incorporated in the Work, or that is necessary for and consumed in the performance of the Contract;
- (g) payments for preparation, delivery, handling, erection, installation, inspection, protection and removal of the Plant and Material necessary for and used in the performance of the Contract; and
- (h) any other payments made by the Contractor with the approval Canada that are necessary for the performance of the Contract in accordance with the Contract Documents.

GC6.4.3 Price Determination - Variations in Tendered Quantities

- 1) Except as provided in paragraphs 2), 3), 4) and 5) of GC6.4.3, if it appears that the final quantity of labour, Plant and Material under a price per unit item shall exceed or be less than the estimated tendered quantity, the Contractor shall perform the Work or supply the Plant and Material required to complete the item and payment shall be made for the actual Work performed or Plant and Material supplied at the price per unit set out in the Contract.
- 2) If the final quantity of the price per unit item exceeds the estimated tendered quantity by more than 15%, either party to the Contract may make a written request to the other party to negotiate an amended price per unit for that portion of the item which exceeds 115% of the estimated tendered quantity, and to facilitate approval of any amended price per unit, the Contractor shall, on request, provide Canada with
 - (a) detailed records of the actual cost to the Contractor of performing or supplying the tendered quantity for the price per unit item up to the time the negotiation was requested; and
 - (b) the estimated unit cost of labour, Plant and Material required for the portion of the item that is in excess of 115% of the tendered quantity.
- 3) If agreement is not reached as contemplated in paragraph 2) of GC6.4.3, the price per unit shall be determined in accordance with GC6.4.2.
- 4) If it appears that the final quantity of labour, Plant and Material under a price per unit item shall be less than 85% of the estimated tendered quantity, either party to the Contract may make a written request to the other party to negotiate a change to the price per unit for the item if

7 SECTION 7
CONTRACT DOCUMENTS – Appendix “C” General Conditions (GC)

- (a) there is a demonstrable difference between the unit cost to the Contractor of performing or supplying the estimated tendered quantity and the unit cost to the Contractor for performing or supplying the final quantity; and
 - (b) the difference in unit cost is due solely to the decrease in quantity and not to any other cause.
- 5) For the purposes of the negotiation referred to in paragraph 4) of GC6.4.3
- (a) the onus of establishing, justifying and quantifying a proposed change lies with the party making the request for negotiation; and
 - (b) in no event shall the total price for an item that has been amended as a result of a reduction in quantity pursuant to paragraph 4) of GC6.4.3 exceed the amount that would have been payable to the Contractor had 85% of the tendered quantity actually been performed or supplied.

GC6.5 DELAYS AND EXTENSION OF TIME

- 1) Upon application of the Contractor made before the date first fixed for completion of the Work or before any other date previously fixed under this clause, Canada may extend the time for completion of the Work by fixing a new date if Canada determines that causes beyond the control of the Contractor have delayed its completion.
- 2) The Contractor's application shall be accompanied by the written consent of the bonding company whose bond forms part of the Contract Security.
- 3) Subject to paragraph 4) of GC6.5, no payment, other than a payment that is expressly stipulated in the Contract, shall be made by Canada to the Contractor for any extra expense, loss or damage incurred or sustained by the Contractor due to delay, whether or not the delay is caused by circumstances beyond the control of the Contractor.
- 4) If the Contractor incurs or sustains any extra expense or any loss or damage that is directly attributable to any neglect or delay that occurs after the date of the Contract on the part of Canada in providing any information or in doing any act that the Contract either expressly requires Canada to do or that would ordinarily be done by an owner in accordance with the practice of the trade, the Contractor shall give Canada written notice of intention to claim for that extra expense or loss or damage within ten working days of the date the neglect or delay first occurred.
- 5) When the Contractor has given a notice referred to in paragraph 4) of GC6.5, the Contractor shall give Canada a written claim for the extra expense, loss or damage no later than 30 days after the date that a Certificate of Completion is issued and not afterwards.
- 6) A written claim referred to in paragraph 5) of GC6.5 shall contain a sufficient description of the facts and circumstances of the occurrence that is the subject of the claim to enable Canada to determine whether or not the claim is justified and the Contractor shall supply such further and other information for that purpose as Canada may require.
- 7) If Canada determines that a claim referred to in paragraph 5) of GC6.5 is justified, Canada shall make an extra payment to the Contractor in an amount that is calculated in accordance with GC6.4 DETERMINATION OF PRICE.
- 8) If the Contractor fails to give a notice referred to in paragraph 5) and a claim referred to in paragraph 4) of GC6.5 within the times stipulated, an extra payment shall not be made to the Contractor in respect of the occurrence.

7 SECTION 7
CONTRACT DOCUMENTS – Appendix “C” General Conditions (GC)

GC7 DEFAULT, SUSPENSION OR TERMINATION OF CONTRACT

GC7.1 TAKING THE WORK OUT OF THE CONTRACTOR’S HANDS

- 1) By giving notice in writing to the Contractor in accordance with GC2.3 NOTICES, Canada, without any other authorization, may take all or any part of the Work out of the Contractor's hands, and may employ such means as Canada sees fit to have the Work completed if the Contractor
 - (a) fails to remedy any delay in the commencement or default in the diligent performance of the Work to the satisfaction of Canada within six days of Canada giving notice to the Contractor in writing in accordance with GC2.3 NOTICES;
 - (b) defaults in the completion of any part of the Work within the time fixed for its completion by the Contract;
 - (c) becomes insolvent, or has committed an act of bankruptcy, and has neither made a proposal to its creditors nor filed a notice of intention to make such a proposal, pursuant to the Bankruptcy and Insolvency Act;
 - (d) abandons the work;
 - (e) makes an assignment of the Contract without the consent required by GC1.17 ASSIGNMENT; or
 - (f) otherwise fails to observe or perform any of the provisions of the Contract.
- 2) If the whole or any part of the Work is taken out of the Contractor's hands, the Contractor's right to any further payment that is due or accruing due under the Contract is, subject only to paragraph 3) of GC7.1, extinguished, and the Contractor is liable to pay Canada, upon demand, an amount that is equal to the amount of all loss and damage incurred or sustained by Canada in respect of the Contractor's failure to complete the Work.
- 3) If the whole or any part of the Work that is taken out of the Contractor's hands is completed by Canada, Canada may pay the Contractor the amount, if any, of the holdback or a progress claim as determined by Canada that had accrued and was due prior to the date on which the Work was taken out of the Contractor's hands and that is not required for the purposes of having the Work performed or of compensating Canada for any other loss or damage incurred or sustained by reason of the Contractor's default.
- 4) The taking of the Work or any part thereof out of the Contractor's hands does not relieve the Contractor from any obligation under the Contract or imposed by law except the obligation to complete the performance of that part of the Work that was taken out of the Contractor's hands.
- 5) If the Work or any part thereof is taken out of the Contractor's hands, all Plant and Material and the interest of the Contractor, or its suppliers or subcontractors at any tier, in all real property, licences, powers and privileges acquired, used or provided by the Contractor, or its suppliers or subcontractors at any tier, under the Contract shall continue to be the property of Canada without compensation.
- 6) When Canada certifies that any Plant, Material, or any interest of the Contractor is no longer required for the purposes of the Work, or that it is not in the interests of Canada to retain that Plant, Material, or interest, it shall revert to the Contractor.
- 7) If the Contractor has become insolvent or has committed an act of bankruptcy, and has either made a proposal to its creditors or filed a notice of intention to make such a proposal, pursuant to the Bankruptcy and Insolvency Act, the Contractor shall immediately forward a copy of the proposal or the notice of intention to Canada.

7 SECTION 7
CONTRACT DOCUMENTS – Appendix “C” General Conditions (GC)

GC7.2 SUSPENSION OF WORK

- 1) When, in Canada's opinion, it is in the public interest to do so, Canada may require the Contractor to suspend performance of the Work either for a specified or an unspecified period, by giving a notice of suspension in writing to the Contractor in accordance with GC2.3 NOTICES.
- 2) When a notice of suspension is received by the Contractor, the Contractor shall suspend all operations in respect of the Work except those that Canada determines are necessary for the care and preservation of the Work, Plant and Material.
- 3) During a period of suspension, the Contractor shall not remove any part of the Work, Plant or Material from its site without the consent of Canada.
- 4) If a period of suspension is 60 days or less, the Contractor shall resume the performance of the Work on the expiration of that period, and the Contractor is entitled to be paid the extra costs necessarily incurred by the Contractor as a result of the suspension, determined in accordance with GC6.4 DETERMINATION OF PRICE.
- 5) If a period of suspension is more than 60 days, Canada and the Contractor may agree that the performance of the Work shall be continued by the Contractor, and the Contractor shall resume performance of the Work subject to any terms and conditions agreed upon by Canada and the Contractor. If Canada and the Contractor do not agree that performance of the Work shall be continued by the Contractor, or upon the terms and conditions under which the Contractor shall continue the Work, the notice of suspension shall be deemed to be a notice of termination pursuant to GC7.3 TERMINATION OF CONTRACT.

GC7.3 TERMINATION OF CONTRACT

- 1) Canada may terminate the Contract at any time by giving a notice of termination in writing to the Contractor in accordance with GC2.3 NOTICES.
- 2) If the Contractor receives a notice of termination, the Contractor shall forthwith cease all operations in performance of the Contract, subject to any conditions stipulated in the notice.
- 3) Subject to paragraph 4) of GC7.3, if the Contract is terminated, Canada shall pay the Contractor an amount determined to be due to the Contractor pursuant to GC6.4 DETERMINATION OF PRICE less the aggregate of all amounts that were paid to the Contractor by Canada and all amounts that are due to Canada from the Contractor pursuant to the Contract.
- 4) In no event shall the total amount payable by Canada to the Contractor exceed the amount, calculated in accordance with GC5 TERMS OF PAYMENT, that would have been payable to the Contractor had the Contractor completed the Work.
- 5) Payment to the Contractor, if any, shall be made as soon as practicable under the circumstances.

GC7.4 SECURITY DEPOSIT - FORFEITURE OR RETURN

- 1) If the Work is taken out of the Contractor's hands, or the Contractor is in breach of, or in default under, the Contract, Canada may convert a security deposit to Canada's own use.
- 2) If Canada converts a security deposit, the amount realized shall be deemed to be an amount due from Canada to the Contractor under the Contract.
- 3) Any balance of the amount realized that remains after payment of all losses, damage and claims of Canada and others shall be paid by Canada to the Contractor if, in the opinion of Canada, it is not required for the purposes of the Contract.

GC8 DISPUTE RESOLUTION

GC8.1 INTERPRETATION

- 1) In these Dispute Resolution Conditions and in the Schedules attached hereto, an "arbitral question of law" means a question of law that
 - (a) is capable of determination by arbitration under the laws of Canada;
 - (b) does not involve interpretation or application of public law of Canada, including without limitation any matter of constitutional, administrative, criminal or tax law; and
 - (c) concerns
 - (i) the formation, validity, interpretation, application or enforceability of the Contract;
 - (ii) the performance, breach, termination or other discharge of the Contract;
 - (iii) the rights, duties, obligations or remedies of parties created by or pursuant to the Contract; or
 - (iv) any other issue of private law that may arise between parties relative to performance of the Contract.

"dispute" means any disagreement regarding any issue identified by the Contractor in the notice submitted to the Departmental Representative and includes any claim by the Contractor arising from such disagreement and any counterclaim by Canada, but does not include any claim by either party for punitive or exemplary damages, injury to persons, death, or any claim based on an allegation of libel or slander; and

"Working Day" means a day other than a Saturday, Sunday or a holiday which is observed by the construction industry in the area where the Work is located.

- 2) The alternative dispute resolution procedures set out in GC8 DISPUTE RESOLUTION, do not apply to any claim by Canada against the Contractor except any counterclaim in a dispute as defined in this GC8.1, including, but not limited to, any claim of setoff regarding any amount due to Canada under GC5.10 ASSESSMENT AND DAMAGES FOR LATE COMPLETION.

GC8.2 CONSULTATION AND CO-OPERATION

- 1) The parties agree to maintain open and honest communication throughout the performance of the Contract.
- 2) The parties agree to consult and co-operate with each other in the furtherance of the work and the resolution of problems or differences which may arise.

GC8.3 AUTHORITY OF DEPARTMENTAL REPRESENTATIVE

- 1) Any difference between the parties to the Contract of any nature arising out of or in connection with the Contract which could result in a claim by the Contractor against Canada, and which is not settled by consultation and co-operation shall be resolved in the first instance by the Departmental Representative, whose written decision or direction shall be final and binding subject only to the provisions of GC8 DISPUTE RESOLUTION. Such written decision or direction includes, but is not limited to, any written decision or direction by the Departmental Representative under any provision of the General Conditions.
- 2) The Contractor shall be deemed to have accepted the decision or direction of the Departmental Representative and to have expressly waived and released Canada from any claim in respect of the particular matter dealt with in that decision or direction unless, within 15 working days after receipt of the decision or direction, the Contractor submits to the Departmental Representative a written notice of dispute requesting formal negotiation under GC8.4 NEGOTIATION. Such notice shall refer specifically to GC8.4 NEGOTIATION, and shall specify the issues in contention and the relevant provisions of the Contract.
- 3) The giving of a written notice in accordance with GC8.2 shall not relieve the Contractor from complying with the decision or direction that is the subject of the dispute. Such compliance, however, shall not be construed as an admission by the Contractor of the correctness of such decision or direction.

7 SECTION 7
CONTRACT DOCUMENTS – Appendix “C” General Conditions (GC)

- 4) If a dispute is not resolved promptly, the Departmental Representative shall give such instructions as, in the Departmental Representative’s opinion, are necessary for the proper performance of the Work and to prevent delays pending a resolution of the matter. Unless the Minister terminates the Contract, orders the Contractor to suspend the work, or takes the work out of the hands of the Contractor, the Contractor shall continue to perform the work in accordance with the provisions and requirements of the Contract and the instructions of the Departmental Representative. Such performance shall not prejudice any claim that the Contractor may have.
- 5) Nothing in GC8 DISPUTE RESOLUTION, relieves the Contractor from its obligation to provide any other notice required by the Contract within the time specified in the Contract.

GC8.4 NEGOTIATION

- 1) Within 10 working days after receipt by the Departmental Representative of a notice referred to in paragraph 2) of GC8.3 AUTHORITY OF THE DEPARTMENTAL REPRESENTATIVE, the parties shall commence formal negotiations in order to resolve the dispute. Negotiations shall occur initially between representatives of the Contractor and Canada who play a direct supervisory role in the performance, administration or management of the Contract.
- 2) If the representatives referred to in paragraph 1) of GC8.4 are unable to resolve some or all of the issues which are the subject of the negotiations within 10 working days, the parties shall refer the remaining issues which are in dispute to a second level of negotiation between a principal or principals of the Contractor and a senior level manager or senior level managers representing Canada.
- 3) If negotiations fail to resolve the dispute within 30 working days from the date of delivery of the notice referred to in paragraph 2) of GC8.3 AUTHORITY OF THE DEPARTMENTAL REPRESENTATIVE, or within such longer period as may have been agreed to by the parties, the Contractor may, by giving written notice to the Departmental Representative, in accordance with GC2.3 NOTICES, within 10 working days from the end of such period, request that mediation be undertaken to assist the parties to reach agreement on the outstanding issues.
- 4) If the Contractor does not request mediation within the period permitted by paragraph 3) of GC8.4, the Contractor shall be deemed to have accepted the decision or direction of the Departmental Representative under paragraph 1) of GC8.3 and to have expressly waived and released Canada from any claim in respect of the particular matter dealt with in that decision or direction.

GC8.5 MEDIATION

- 1) If the Contractor has requested mediation in accordance with paragraph 3) of GC8.4 NEGOTIATION, mediation shall be conducted in accordance with the current issue of Public Works and Government Services Canada Rules for Mediation of Construction Contract Disputes.
- 2) If a Project Mediator has not previously been appointed for the purposes of the Contract, a Project Mediator shall be appointed forthwith after delivery of a notice in accordance with paragraph 3) of GC8.4 NEGOTIATION, requesting mediation.
- 3) If the dispute has not been resolved within
 - (a) 10 working days following the appointment of a Project Mediator in accordance with paragraph 2) of GC8.5, if a Project Mediator was not previously appointed;
 - (b) 10 working days following receipt by the Departmental Representative of a written notice in accordance with paragraph 4) of GC8.4 NEGOTIATION, if a Project Mediator was previously appointed; or
 - (c) such other longer period as may have been agreed to by the parties;the Project Mediator shall terminate the mediation by giving written notice to the parties stating the effective date of termination.

7 SECTION 7
CONTRACT DOCUMENTS – Appendix “C” General Conditions (GC)

GC8.6 BINDING ARBITRATION

- 1) If mediation of the dispute is terminated pursuant to the provisions of GC8.5 MEDIATION, and
 - (a) the termination of mediation occurs prior to the applicable date set out in paragraph 4) of GC8.6; and
 - (b) the disputed issues involve issues of fact or issues of arbitral questions of law or issues of mixed fact and arbitral questions of law;either party, by giving notice in writing to the other party in accordance with GC11 of the General Conditions, may require that the dispute be resolved by binding arbitration pursuant to this GC8.6 BINDING ARBITRATION.
- 2) A notice referred to in paragraph 1) of GC8.6 shall be given within 10 working days of the date of termination of mediation under GC8.5 MEDIATION. If delivered personally, a notice to the Contractor shall be delivered to the Contractor if the Contractor is doing business as a sole proprietor or, if the Contractor is a partnership or corporation, to an officer thereof.
- 3) If no notice is given within the period set out in paragraph 2) of GC8.6, or if the conditions set out in subparagraphs 1) (a) and 1) (b) of GC8.6 are not met, the arbitration provisions set out in this GC8.6 do not apply to the dispute.
- 4) Unless otherwise agreed, the arbitration of the dispute shall be held in abeyance until the earlier of
 - (a) the date of issuance of an Interim Certificate of Completion under GC5.5;
 - (b) the date the work is taken out of the Contractor's hands; and
 - (c) the date of termination of the Contract;and consolidated with all other such disputes into a single arbitration.
- 5) Arbitral proceedings under this GC8.6 shall be governed by and conducted in accordance with the *Commercial Arbitration Act*, R.S.C. 1985, c. 17 (2nd Supp.) and the provisions of the Public Works and Government Services Canada Rules for Arbitration of Construction Contract Disputes.
- 6) For the purposes of calculating time under the Rules for Arbitration referred to in paragraph 5) of GC8.6, arbitration proceedings shall commence on the applicable date set out in paragraph 4) of GC8.6.
- 7) The arbitration provisions in GC8.6 do not apply if the aggregate amount of all claims by the Contractor required to be arbitrated on the applicable date set out in paragraph 4) of GC8.6 is less than \$25,000.

GC8.7 DISPUTES NOT SUBJECT TO ARBITRATION

- 1) Where the arbitration provisions in GC8.6 BINDING ARBITRATION, do not apply to a dispute as a result of paragraphs 3) or 7) of GC8.6 BINDING ARBITRATION, either party may take such court action or proceedings as it considers appropriate, including, without limiting the foregoing, all suits that would otherwise have been immediately available to it but for the provisions of these Dispute Resolution Conditions. Subject to the provisions of paragraph 2) of GC8.7, the Contractor shall initiate any such action or proceeding no later than three calendar months after the date that a Final Certificate of Completion is issued under GC5.6 and not afterwards.
- 2) Any action or proceeding resulting from a direction under GC3.12 WARRANTY AND RECTIFICATION OF DEFECTS IN WORK, shall be initiated by the Contractor no later than three calendar months after the expiry of the warranty or guarantee period and not afterwards.

GC8.8 CONFIDENTIALITY

- 1) All information exchanged during alternative dispute resolution procedures, by whatever means, shall be without prejudice and shall be treated as confidential by the parties and their representatives, unless otherwise required by law. However, evidence that is independently admissible or discoverable shall not be rendered inadmissible or non-discoverable by virtue of its use during an alternative dispute resolution process.

GC8.9 SETTLEMENT

- 1) Any agreement to settle all or any part of a dispute, by whatever means, shall be in writing and be signed by the parties or their authorized representatives.

DISPUTE RESOLUTION - SCHEDULE "A"
RULES FOR MEDIATION OF CONSTRUCTION CONTRACT DISPUTES

DRA01 INTERPRETATION

- 1) Terms defined in the Contract and used in these Rules shall have the meaning assigned to them in the Contract.

DRA02 APPLICATION

- 1) These Rules apply to mediation conducted under the Contract. By mutual agreement, the parties may change or make additions to the Rules.

DRA03 COMMUNICATION

- 1) Written communications pursuant to these Rules shall be given in the same manner as written notices are to be given pursuant to the Contract.

DRA04 APPOINTMENT OF PROJECT MEDIATOR

- 1) The parties to the Contract may, by mutual consent, at any time after entry into the Contract, appoint a mediator (the “Project Mediator”) to conduct mediation proceedings in accordance with these Rules for Mediation of Construction Disputes, in regard to any dispute that may arise with regard to the interpretation, application or administration of the Contract. In this case, they shall jointly enter into a contract with the appointed Project Mediator, which contract shall be in a form drafted by the Coordinator and agreed to by the parties. The contract shall stipulate that, subject to any subsequent agreement between the parties to the contrary, the Project Mediator shall terminate any mediation proceeding if the dispute at issue has not been resolved within 10 working days following the date of commencement of the proceeding.
- 2) If the parties do not appoint a Project Mediator pursuant to paragraph 1) of DRA04, the parties shall appoint a Project Mediator within 10 working days following receipt of a written notice from the Contractor, in accordance with the provisions of the Contract, requesting that mediated negotiations be undertaken in accordance with these Rules to assist the parties to reach agreement on any outstanding issues that may be in dispute. Any contract entered into with the appointed Project Mediator shall meet the requirements as set out for the contract described in paragraph 1) of DRA04.
- 3) When mediation is requested by the Contractor pursuant to the terms of the Contract, if the parties have previously entered into a contract with a Project Mediator, the parties shall forthwith send to both the Project Mediator and the Coordinator
 - (a) a copy of the notice requesting negotiation under the terms of the Contract;
 - (b) a copy of Canada’s written position in relation to the notice, the issues in contention and the relevant provisions of the contract; and
 - (c) a copy of the Contractor’s written request for mediation required under the terms of the Contract.

7 SECTION 7
CONTRACT DOCUMENTS – Appendix “C” General Conditions (GC)

- 4) If the parties have not agreed on a Project Mediator, the parties shall forthwith provide the Coordinator with the written materials referred to in subparagraphs 3)(a), 3)(b) and 3)(c) of DRA04 together with a request that the Coordinator assist in the appointment of a mutually acceptable Project Mediator in accordance with these Rules. Each party may include with the written materials the names of qualified private sector mediators that the party wishes to have included in the list referred to in paragraph 5) of DRA04.
- 5) Within 5 working days following receipt of the request and materials referred to in paragraph 4) of DRA04, the Coordinator shall provide the parties with a list of qualified private sector mediators together with instructions to each party to individually and confidentially select and rank their preferred and fully acceptable choices of mediator in descending order. Each mediator listed shall be, in the opinion of the Coordinator, impartial and independent of the parties, and shall be an experienced and skilled commercial mediator, preferably with knowledge of the subject matter of the dispute.
- 6) Within 10 working days of receipt of the list referred to in paragraph 5) of DRA04 each party shall comply with the instructions accompanying the list(s) and shall deliver the completed listing to the Coordinator.
- 7) Within 2 working days following receipt of the completed listings, the Coordinator shall select the highest common ranked mediator to act as Project Mediator for the purposes of the contract.
- 8) In the event of a tie, the Coordinator shall consult both parties to re-evaluate their rankings in order to assist the Coordinator in selecting a Project Mediator acceptable to both parties. If the parties cannot agree upon a Project Mediator, the Coordinator shall forthwith provide the parties with a second list of mediators and the procedure shall be repeated.
- 9) If the parties have not previously entered into a contract with a mutually acceptable Project Mediator, the Coordinator shall use reasonable efforts to negotiate a contract with a mutually acceptable Project Mediator on behalf of the parties, which contract shall incorporate or otherwise comply with the provisions of these Rules. If negotiations are unsuccessful, or if for other reason the individual is unwilling or unable to enter into a contract to act as Project Mediator, the Coordinator shall repeat the process with the second-highest common ranked mediator.
- 10) The parties agree that, upon successful completion of the negotiations referred to in paragraph 9) of DRA04, they shall jointly enter into a contract with the selected Project Mediator, which agreement shall be in a form drafted by the Coordinator and agreed to by the parties. The contract shall stipulate that, subject to any subsequent agreement between the parties to the contrary, the Project Mediator shall terminate any mediation proceeding if the dispute at issue has not been resolved within 10 working days following the date of commencement of the proceeding.
- 11) Upon execution of the contract with the Project Mediator referred to in paragraph 10) of DRA04 the Coordinator shall provide the Project Mediator with copies of the documents referred to in paragraph 3) of DRA04.

DRA05 CONFIDENTIALITY

- 1) Subject to paragraph 2) of DRA05, and unless otherwise agreed in writing by the parties, the Project Mediator, the parties and their counsel or representatives shall keep confidential all matters and documents disclosed during mediation proceedings except where the disclosure is necessary for any implementation of any agreement reached or is required by law.
- 2) Evidence that is independently admissible or discoverable in any arbitral or judicial proceeding shall not be rendered inadmissible or non-discoverable by virtue of its use in mediation proceedings.
- 3) Neither party shall make transcripts, minutes or other records of a mediation conference.
- 4) The personal notes and written opinions of the Project Mediator made in relation to mediation are in the Project Mediator's sole possession and control, are confidential, and may not be used in any subsequent proceeding between the parties or where they are opposed in interest without the express written permission of the parties.

7 SECTION 7
CONTRACT DOCUMENTS – Appendix “C” General Conditions (GC)

- 5) All information exchanged during mediation procedures, by whatever means, shall be without prejudice and shall be treated as confidential by the parties and their representatives, unless otherwise required by law.

DRA06 TIME AND PLACE OF MEDIATION

- 1) The Project Mediator, in consultation with the parties shall set the date, time and place of any mediation conference as soon as possible, bearing in mind that, subject to agreement to the contrary between the parties, only 10 working days are available within which to attempt to settle the dispute.

DRA07 REPRESENTATION

- 1) Representatives of the parties may be accompanied at the mediation conference by legal counsel or any other person.
- 2) If the Project Mediator is a lawyer, the Project Mediator shall not provide legal advice to a party during the course of the mediation conference, but may recommend that a party obtain independent legal advice before finalizing a settlement agreement.

DRA08 PROCEDURE

- 1) The parties agree to an exchange of all facts, information and documents upon which they intend to rely in any oral or written presentation during the mediation. This exchange shall be completed no later than 2 working days prior to the date set for a mediation conference.
- 2) The Project Mediator shall be free to meet with the parties individually during a mediation conference if the Project Mediator is of the opinion that this may improve the chances of a mediated settlement, and either party may request such an individual meeting at any time.
- 3) The parties may agree to extend the 10 working days mediated negotiation period, and the Project Mediator shall record that agreement in writing.

DRA09 SETTLEMENT AGREEMENT

- 1) The parties shall record in writing any settlement agreement reached, with sufficient detail to ensure a clear understanding of
- (a) the issues resolved;
 - (b) any obligations assumed by each party including criteria to determine if and when these obligations have been met; and
 - (c) the consequences of failure to comply with the agreement reached.
- 2) The parties agree to carry out the terms of a settlement agreement as soon as possible and, in any event, within any time periods specified in the agreement.

DRA10 TERMINATION OF MEDIATION

- 1) Either party may withdraw from mediation at any time without reason and, in that event, the Project Mediator shall give each party a written notice terminating the mediation and establishing the effective date of termination.
- 2) If, in the opinion of the Project Mediator, either party fails to mediate in good faith or fails to comply with the terms of these Rules, or if the Project Mediator, at any time during mediation, is of the opinion that further negotiations will fail to resolve the issues outstanding, the Project Mediator may terminate the negotiations by providing the parties with a written notice of termination, stating therein the Project Mediator's reasons for the termination, and the effective date of termination.

7 SECTION 7
CONTRACT DOCUMENTS – Appendix “C” General Conditions (GC)

- 3) If a dispute has not been resolved within 10 working days or such other longer period as may have been agreed to by the parties, the Project Mediator shall terminate the mediation by giving written notice to the parties stating the effective date of termination.

DRA11 COSTS

- 1) The parties agree that they will each be responsible for the costs of their own representatives and advisors and associated travel and living expenses. Fees and expenses of the Project Mediator and all administrative costs of mediation, such as the cost of the meeting room(s), if any, shall be borne equally by the parties.

DRA12 SUBSEQUENT PROCEEDINGS

- 1) The parties shall not rely on or introduce as evidence in any arbitral or judicial proceeding, whether or not such proceeding relates to the subject matter of mediation,
- (a) any documents of other parties that are not otherwise producible in those proceedings;
 - (b) any views expressed or suggestions made by any party in respect of a possible settlement of issues;
 - (c) any admission made by any party in the course of mediation unless otherwise stipulated by the admitting party; and
 - (d) the fact that any party has indicated a willingness to make or accept a proposal or recommendation for settlement.
- 2) The Project Mediator shall neither represent nor testify on behalf of either of the parties in any subsequent investigation, action or proceeding relating to the issues in mediation proceedings.
- 3) The Project Mediator shall not be subpoenaed to give evidence relating to
- (a) the Project Mediator's role in mediation; or
 - (b) the matters or issues in mediation;
- in any subsequent investigation, action or proceeding and the parties agree to vigorously oppose any effort to have the Mediator so subpoenaed.

DISPUTE RESOLUTION - SCHEDULE B
RULES FOR ARBITRATION OF CONSTRUCTION CONTRACT DISPUTES

DRB01 INTERPRETATION

- 1) Terms defined in the Contract and used in these Rules shall have the meaning assigned to them in the Contract.
- 2) In these Rules
- “claimant” means the Contractor;
- “respondent” means Her Majesty.

7 SECTION 7
CONTRACT DOCUMENTS – Appendix “C” General Conditions (GC)

DRB02 ARBITRATION TRIBUNAL

- 1) Subject to these Rules, and unless otherwise agreed by the parties, the arbitration tribunal shall consist of a single arbitrator (“the Tribunal”) who shall be appointed in accordance with the provisions of the Rules.

DRB03 APPLICATION

- 1) These Rules apply to arbitration conducted under the Contract. By mutual agreement, the parties may change or make additions to the Rules.
- 2) The scope of the arbitral proceedings shall be limited to the resolution of the dispute submitted to arbitration.
- 3) The dispute shall be subject to resolution pursuant to the provisions of these Rules whether or not such resolution requires determination of a question of law if such question of law is an arbitral question of law as defined in the terms and conditions of the Contract.
- 4) Arbitral proceedings shall be governed by and in accordance with the *Commercial Arbitration Act*, R.S.C. 1985, c. 17 (2nd Supp.), the Code referred to therein, and the provisions of these Rules, and, subject only to the provisions of the Commercial Arbitration Act, the parties agree that the determination and award of the Tribunal shall be final and binding on both parties.
- 5) The Tribunal shall not decide the dispute ex aequo et bono or as amiable compositeur.
- 6) The Tribunal shall decide in accordance with the terms and conditions of the Contract and shall take into account the usage of the trade applicable to the transaction.
- 7) The costs of the Tribunal and the arbitration shall be shared equally by the parties and each party shall bear its own costs.

DRB04 INITIATION OF PROCEEDINGS

- 1) Either party may submit a dispute to binding arbitration to the extent permitted under the Contract, by giving notice in writing to the other party in accordance with the requirements of the Contract.
- 2) The notice referred to in paragraph 1) of DRB04 shall contain the following:
 - (a) a brief description of the Contract;
 - (b) a statement of the issue(s) in dispute;
 - (c) a request that the dispute be referred to binding arbitration; and
- 3) A copy of the notice referred to in paragraph 1) of DRB04 shall be given to the Coordinator at the same time it is given to the other party.

DRB05 APPOINTMENT OF TRIBUNAL

- 1) No later than 10 working days following the date of commencement of arbitration proceedings as set out in the Contract documents, the Coordinator shall assemble and provide the parties with a list of qualified private sector arbitrators together with instructions to each party to individually and confidentially select and rank their preferred and fully acceptable choices of arbitrator in descending order.
- 2) Within 5 working days following receipt of the list referred to in paragraph 1) of DRB05, either party may request the Coordinator in writing to add additional private sector arbitrators to the list who, in the opinion of the party, meet the necessary qualification requirements, and forthwith upon receipt of the request, the Coordinator shall add the additional names to the list and provide the parties with a copy of the amended list.

7 SECTION 7
CONTRACT DOCUMENTS – Appendix “C” General Conditions (GC)

- 3) Within 10 working days of receipt of the list referred to in paragraph 1) of DRB05 or an amended list referred to in paragraph 2) of DRB05, whichever is later, each party shall comply with the instructions accompanying the list(s) and shall deliver the completed listing to the Coordinator.
- 4) Within 2 working days following receipt of the completed listings, the Coordinator shall select the highest common ranked arbitrator to act as the Tribunal for the purposes of the arbitration.
- 5) In the event of a tie, the Coordinator shall consult both parties to re-evaluate their rankings in order to assist the Coordinator in selecting a single arbitrator acceptable to both parties. If the parties cannot agree upon an arbitrator, the Coordinator shall forthwith provide the parties with a second list of arbitrators and the procedure shall be repeated.
- 6) In the event that, following the repeated procedure, the Coordinator again fails to select a single arbitrator acceptable to both parties, the Tribunal shall consist of three (3) arbitrators, one arbitrator appointed by each of the parties and the third arbitrator appointed by these two (2) arbitrators.
- 7) The Tribunal shall in any event be composed of a person or persons who have experience in the subject matter of the dispute and are independent of either party. Without limiting the generality of the foregoing, the Tribunal shall be at arm's length from both parties and shall not be composed of members of any company, firm, or agency which advises either party, nor shall the Tribunal be composed of a person or persons who are otherwise regularly retained by such parties.
- 8) The parties agree that they shall jointly enter into an agreement with the selected Tribunal, which agreement shall be in a form drafted by the Coordinator and agreed to by the parties.
- 9) The parties agree that they shall each bear their own costs. Fees and reasonable expenses of the Tribunal and reasonable expenses associated with the conduct of the arbitration shall be borne equally by the parties.

DRB06 PRELIMINARY MEETING

- 1) Unless the parties to the arbitration and the Tribunal otherwise agree, the parties shall meet with the Tribunal within 10 working days of the Tribunal's appointment to
 - (a) settle the location of premises for proceedings and responsibilities for the arrangement;
 - (b) verify addresses for the delivery of written communications to each party and to the Tribunal;
 - (c) present to the Tribunal the issues to be resolved by means of the arbitration;
 - (d) estimate the length of time the hearing might take and the number of witnesses likely to be produced;
 - (e) determine if a stenographic record or any other type of recording of proceedings should be kept, or if any particular services, such as interpreters, translations or security measures should be provided; and
 - (f) determine any other matters pertinent to conduct of the arbitration.

DRB07 COMMUNICATIONS

- 1) Subject to paragraph 2) of DRB07, the Tribunal shall not communicate with a party to the dispute except in the presence of the other party.
- 2) Notwithstanding paragraph 1) of DRB07, the Tribunal may communicate with the parties separately for the purpose of establishing procedures to be followed or setting the time of a meeting; other exceptions to the general rule shall only be made with the consent in writing of all parties.
- 3) If a communication by the Tribunal to one party is in writing, a copy shall be sent to the other party.
- 4) If a party sends any written communication to the Tribunal, a copy shall be sent to the other party.

7 SECTION 7
CONTRACT DOCUMENTS – Appendix “C” General Conditions (GC)

- 5) Any communication that is required or permitted to be given to the Tribunal or either party shall be in writing and may be given by delivering the same by facsimile, electronic mail or by mail, postage prepaid, to the address established for the purposes of the Contract in the case of the parties, and to the address provided by the Tribunal in the case of the Tribunal, and such communication shall be deemed to have been received in accordance with the provisions of the General Conditions of the Contract.

DRB08 REPRESENTATION

- 1) The parties may be represented or assisted by any person during the arbitral proceedings.

DRB09 CONDUCT OF PROCEEDINGS

- 1) Subject to the provisions of these Rules, the Tribunal may conduct the arbitration in the manner it considers appropriate. The power conferred upon the Tribunal includes the power to determine the admissibility, relevance, materiality and weight of any evidence.

DRB10 PLACE OF ARBITRATION

- 1) The Tribunal may meet at any place it considers appropriate for hearing witnesses, experts or the parties, or for inspection of documents, goods or other property. The Tribunal shall conduct on-site inspections at the request of either party. Any on-site inspections shall be made in the presence of both parties and their representatives. The proceedings of any on-site inspections shall be recorded as part of the hearing itself.

DRB11 TIME LIMITATIONS

- 1) The Tribunal may extend or abridge a period of time required in these Rules or fixed or determined by the Tribunal where the Tribunal considers it to be reasonable and appropriate.
- 2) Where any proceeding is terminated pursuant to paragraph 25(a) or 32 (2)(a) of the Code referred to in the *Commercial Arbitration Act*, unless the respondent agrees otherwise in writing, such termination is deemed to be a final award dismissing the claim of the claimant.

DRB12 STATEMENT OF CLAIM AND DEFENCE

- 1) Within 10 working days after the Tribunal has been appointed, the claimant shall state, in writing, the facts supporting its claim, points at issue and relief or remedy sought, and shall submit the statement to the respondent, the Coordinator, and the Tribunal.
- 2) Within 10 working days after receipt of the statement of claim, the respondent shall state, in writing, its defence in respect of these particulars and any counterclaim and shall submit its statement to the claimant, the Coordinator and the Tribunal.
- 3) Within 5 working days after receipt of the statement of defence, the claimant may state, in writing, its response to the defence and to any counterclaim, and shall submit its statement to the respondent, the Coordinator and the Tribunal.
- 4) A party may amend or supplement its statements during the course of arbitral proceedings unless the Tribunal considers it inappropriate to allow such amendment or supplement having regard to all circumstances including delay in making the amendment or supplement.
- 5) A statement may not be amended if the amended statement would fall outside the scope of the arbitration agreement.

DRB13 FURTHER WRITTEN STATEMENTS

- 1) The Tribunal may require or permit the presentation of further written statements by the parties and shall fix the periods of time for submitting those statements.

DRB14 AGREED STATEMENT OF FACTS

- 1) Within a time period specified by the Tribunal, the parties shall prepare and file with the Tribunal an agreed statement of facts including but not limited to a chronology of the project, schedules, quantities and progress payments. The Tribunal shall make itself available, upon reasonable notice, to assist the parties to arrive at agreement on as many facts as possible under the circumstances.
- 2) Within a time period specified by the Tribunal, the parties shall prepare and file with the Tribunal a common book of documents including all documents referred to in an agreed statement of facts and in statements of claim, defence and response.

DRB15 EVIDENCE

- 1) Each party shall prove the facts relied upon to support its claim or defence.
- 2) Each party shall deliver to the Tribunal and to the other party, within such period of time that the Tribunal determines, a copy of the documents and a summary of the other evidence that party intends to present in support of the facts in issue set out in its statement of claim, defence or response.
- 3) From time to time, the Tribunal may require the parties to produce documents, exhibits and other evidence within such period of time that the Tribunal may determine.

DRB16 HEARINGS

- 1) All statements, documents or other information supplied to, or applications made to, the Tribunal by one party shall be communicated to the other party, and any expert report or evidentiary document on which the Tribunal may rely in making its decision shall be communicated to the parties at least 8 working days prior to its entry in evidence.
- 2) The parties shall be given reasonably sufficient advance notice of any hearing of the Tribunal and any meeting of the Tribunal for the purpose of inspection of documents, goods or other property.
- 3) If a party intends to give evidence through a witness, the party shall communicate to the Tribunal and to the other party, within such period that the Tribunal determines
 - (a) the names, addresses and curriculum vitae of each of the witnesses it intends to present; and
 - (b) the subject upon which those witnesses shall give their testimony.
- 4) Each party shall have the right to examine, cross-examine and re-examine all witnesses as appropriate.
- 5) All oral hearings and meetings in arbitral proceedings shall be held "in camera".

DRB17 DEFAULT

- 1) Where, without showing sufficient cause, the claimant fails to communicate its statement of claim in accordance with these Rules or within such further period of time permitted by the Tribunal under these Rules, the Tribunal shall issue an order terminating the arbitral proceedings with respect to that claim.
- 2) An order made under paragraph 1) of DRB17 does not affect a counterclaim made in respect of those arbitral proceedings.

7 SECTION 7
CONTRACT DOCUMENTS – Appendix “C” General Conditions (GC)

- 3) Where, without showing sufficient cause, the respondent fails to communicate a statement of defence in accordance with these Rules, or within such further period of time permitted by the Tribunal under these Rules, the Tribunal shall continue the arbitral proceedings without treating that failure in itself as an admission of the claimant's allegations.
- 4) Where, without showing sufficient cause, a party fails to appear at an oral hearing or produce documentary evidence, the Tribunal may continue the arbitral proceedings and make the arbitral award on the evidence before it.

DRB18 ARBITRAL DECISION

- 1) Unless otherwise agreed to by the parties, the Tribunal shall make the award no later than 30 days after completion of the arbitration hearings unless that time period is extended for an express period by the Tribunal on written notice to each party, due to illness or other cause beyond the Tribunal's control.

GC9 CONTRACT SECURITY

GC9.1 OBLIGATION TO PROVIDE CONTRACT SECURITY

- 1) The Contractor shall, at the Contractor's expense and within 14 days after the date that the Contractor receives notice that the Contractor's tender was accepted by Canada, obtain and deliver Contract Security to Canada in one or more of the forms prescribed in GC9.2 TYPES AND AMOUNTS OF CONTRACT SECURITY.
- 2) If the whole or a part of the Contract Security provided is in the form of a security deposit, it shall be held and disposed of in accordance with GC5.13 RETURN OF SECURITY DEPOSIT and GC7.4 SECURITY DEPOSIT - FORFEITURE OR RETURN.
- 3) If a part of the Contract Security provided is in the form of a labour and material payment bond, the Contractor shall post a copy of that bond at the site of the Work.
- 4) It is a condition precedent to the release of the first progress payment that the Contractor has provided the Contract Security as specified herein.

GC9.2 TYPES AND AMOUNTS OF CONTRACT SECURITY

- 1) The Contractor shall deliver to Canada
 - (a) a performance bond and a labour and material payment bond each in an amount that is equal to not less than 50% of the Contract Amount;
 - (b) a labour and material payment bond in an amount that is equal to not less than 50% of the Contract Amount, and a security deposit in an amount that is equal to
 - (i) not less than 10% of the Contract Amount if that Amount does not exceed \$1,000,000; or
 - (ii) \$100,000 plus 5% of the part of the Contract Amount that exceeds \$1,000,000; or
 - (c) a security deposit in an amount prescribed by subparagraph 1)(b) herein, plus an additional amount that is equal to 10% of the Contract Amount.
- 2) The amount of a security deposit referred to in subparagraph 1)(b) of GC9.2 shall not exceed \$2,000,000 regardless of the Contract Amount.
- 3) A performance bond and a labour and material payment bond referred to in paragraph 1) of GC9.2 shall be in a form and be issued by a bonding or surety company that is approved by Canada.

7 SECTION 7
CONTRACT DOCUMENTS – Appendix “C” General Conditions (GC)

- (a) The approved form for the labour and material payment bond may be found at <http://www.pwgsc.gc.ca/sos/corporate/sm/text/ch07nx-02-e.html>;
 - (b) The approved form of the performance bond may be found at <http://www.pwgsc.gc.ca/sos/corporate/sm/text/ch07nx-03-e.html>; and
 - (c) The list of approved bonding or surety companies may be found at http://www.tbs-sct.gc.ca/pubs_pol/dcgpubs/Contracting/contractingpol_l_e.asp
- 4) A security deposit referred to in subparagraphs 1)(b) and 1)(c) of GC9.2 shall be in the form of
- (a) a bill of exchange, bank draft or money order made payable to the Receiver General for Canada and certified by an approved financial institution or drawn by an approved financial institution on itself;
 - (b) bonds of, or unconditionally guaranteed as to principal and interest by, the Government of Canada; or
- 5) For the purposes of subparagraph 4)(a) of GC9.2
- (a) a bill of exchange is an unconditional order in writing signed by the Contractor and addressed to an approved financial institution, requiring the said institution to pay, on demand, at a fixed or determinable future time a sum certain of money to, or to the order of, the Receiver General for Canada;
 - (b) if a bill of exchange, bank draft or money order is certified by or drawn on an institution or corporation other than a chartered bank, it must be accompanied by proof that the said institution or corporation meets at least one of the criteria described in subparagraph 5) (c) of GC9.2, either by letter or by a stamped certification on the bill of exchange, bank draft or money; and
 - (c) An approved financial institution is
 - (i) a corporation or institution that is a member of the Canadian Payments Association as defined in the Canadian Payments Act;
 - (ii) a corporation that accepts deposits that are insured, to the maximum permitted by law, by the Canada Deposit Insurance Corporation or the Régie de l'assurance-dépôts du Québec;
 - (iii) a corporation that accepts deposits from the public if repayment of the deposit is guaranteed by Her Majesty the Queen in right of a province;
 - (iv) a corporation, association or federation incorporated or organized as a credit union or co-operative credit society that conforms to the requirements of a credit union which are more particularly described in paragraph 137(6) of the Income Tax Act; or
 - (v) Canada Post Corporation.
- 6) Bonds referred to in subparagraph 4) (b) of GC9.2 shall be provided on the basis of their market value current at the date of the Contract, and shall be
- (a) made payable to bearer;
 - (b) accompanied by a duly executed instrument of transfer of the bonds to the Receiver General for Canada in the form prescribed by the Domestic Bonds of Canada Regulations; or
 - (c) registered as to principal, or as to principal and interest, in the name of the Receiver General for Canada pursuant to the Domestic Bonds of Canada Regulations.

7 SECTION 7
CONTRACT DOCUMENTS – Appendix “C” General Conditions (GC)

GC9.3 IRREVOCABLE STANDBY LETTER OF CREDIT

- 1) As an alternative to a security deposit, an irrevocable standby letter of credit is acceptable to Canada, the amount of which shall be determined in the same manner as a security deposit referred to in GC9.2 TYPES AND AMOUNTS OF CONTRACT SECURITY.
- 2) An irrevocable standby letter of credit shall
 - (a) be an arrangement, however named or described, whereby a financial institution (the “Issuer”) acting at the request and on the instructions of a customer (the “Applicant”) or on its own behalf,
 - (i) is to make a payment to, or to the order of, Canada as the beneficiary;
 - (ii) is to accept and pay bills of exchange drawn by Canada;
 - (iii) authorizes another financial institution to effect such payment or accept and pay such bills of exchange; or
 - (iv) authorizes another financial institution to negotiate against written demand(s) for payment provided that the terms and conditions of the letter of credit are complied with;
 - (b) state the face amount that may be drawn against it;
 - (c) state its expiry date;
 - (d) provide for sight payment to the Receiver General for Canada by way of the financial institution’s draft against presentation of a written demand for payment signed by Canada identified in the letter of credit by Canada;
 - (e) provide that more than one written demand for payment may be presented subject to the sum of those demands not exceeding the face value of the letter of credit;
 - (f) provide that it is subject to the International Chamber of Commerce (ICC) Uniform Customs and Practice for Documentary Credits, 1993 Revision, ICC Publication No. 500;
 - (g) clearly specify that it is irrevocable or deemed to be irrevocable pursuant to article 6 c) of the International Chamber of Commerce (ICC) Uniform Customs and Practice for Documentary Credits, 1993 Revision, ICC Publication No. 500; and
 - (h) be issued or confirmed, in either official language in a format left to the discretion of the issuer or confirmer, by an approved financial institution on its letterhead.

GC10 INSURANCE

GC10.1 INSURANCE

- 1) The Contractor, at the Contractor's expense, shall obtain and maintain, or shall cause to be obtained and maintained, insurance contracts in respect of the Work, and in accordance with the requirements of GC10 INSURANCE.
- 2) Within thirty (30) days after acceptance of the Contractor's tender, unless otherwise directed in writing by the Departmental Representative, the Contractor shall deposit with the Departmental Representative an Insurer's Certificate(s) of Insurance substantially in the form displayed in this document and, if requested by the Departmental Representative, the originals or certified true copies of all contracts of insurance maintained by, or on behalf of, the Contractor as might be applicable pursuant to the insurance coverage requirements contained in the Contract.

7 SECTION 7
CONTRACT DOCUMENTS – Appendix “C” General Conditions (GC)

GC10.2 RISK MANAGEMENT

- 1) The provisions of the insurance coverage requirements contained in the Contract are not intended to cover all of the Contractor's obligations under GC1.6 INDEMNIFICATION BY CONTRACTOR. Any additional risk management measures or additional insurance coverage the Contractor may deem necessary to fulfill the Contractor's obligations under GC1.6 shall be at the Contractor's discretion and expense.

GC10.3 PAYMENT OF DEDUCTIBLE

- 1) The payment of monies up to the deductible amount made in satisfaction of a claim shall be at the cost of the Contractor.

GC10.4 PERIOD OF INSURANCE

- 1) Unless otherwise directed in writing by the Departmental Representative, the insurance policies shall be in force and be maintained from the date of award of the Contract until the date of issue of the Final Certificate of Completion.

GC10.5 COMMERCIAL GENERAL LIABILITY

GC10.5.1 Scope of Insurance Policy

- 1) Contractors must provide “Commercial General Liability Insurance” and maintain this insurance in force during tender and during the life of the Contract, for a limit of liability NOT LESS THAN \$2,000,000.00 per accident or occurrence. The policy shall be written on a form similar to that known and referred to in the insurance industry as IBC 2100 - Commercial General Liability policy (Occurrence form). Legal or defense costs incurred in respect of a claim or claims shall not operate to decrease the limit of liability.

GC10.5.2 Insurance Policy Endorsements

For Contract Award purposes, the policy must include the following endorsements:

- (a) Additional Insured: Canada is included as an additional insured, but only with respect to liabilities that may arise from the Contractor's own negligence, in the performance of the Contract.
- (b) Notice of Cancellation: The Insurer agrees to provide the Contracting Authority thirty (30) days written notice of policy cancellation.
- (c) Liability arising out of, or resulting from, ownership, existence, maintenance or use of premises by the Contractor and operations necessary for, or incidental to, the performance of the Contract.
- (d) "Broad Form" Property Damage including the loss of use of property.
- (e) Removal or weakening of support of any building or land whether such support be natural or otherwise;
- (f) Elevator liability including escalators, hoists and similar devices;
- (g) Contractor's Protective Liability;
- (h) Contractual and Assumed Liabilities under the Contract;
- (i) Completed Operations Liability - The insurance, including all aspects of these Insurance Conditions shall continue for a period of at least one (1) year beyond the date of the Final Certificate of Completion for the Completed Operations;
- (j) Cross Liability: Without increasing the limit of liability, the policy shall protect all insured parties to the full extent of coverage provided. The policy shall apply to each Insured in the same manner and to the same extent as if a separate policy had been issued to each.
- (k) Joint and Several Liability: The policy shall respond to liability arising from negligence of the insured Contractor, any Insured, or joint negligence of Insured parties.
- (l) Contractual Liability: The policy shall, on a blanket basis or by specific reference to this Contract, extend to assumed liabilities with respect to contractual insurance provisions.
- (m) Contingent Employer's Liability: To protect the Contractor for liabilities arising in the management and administration of statutory and contractual entitlements of its employees.
- (n) Employees and Volunteers as Additional Insured: All employees and volunteers, on behalf of the Contractor, shall be included as additional insured.
- (o) Voluntary Medical Payments, \$5,000.00 per person, \$25,000.00 per accident: To provide, without contestation, for expenses incurred in instances of minor accidental bodily injuries.

7 SECTION 7
CONTRACT DOCUMENTS – Appendix “C” General Conditions (GC)

(p) Severability of Interests: without increasing the limit of liability, this policy shall apply separately to each Insured in the same manner and to the same extent as if a separate policy had been issued to each.

(r) Loss or Damage to Crown Property - This policy, subject to the limits of liability stated herein, shall apply to any loss or damage to Crown Property under the care, custody or control of the Design-Builder.

GC10.5.3 Additional Exposures

- 1) The policy shall either include, or be endorsed to include, the following exposures or hazards if the Work is subject thereto:
 - (a) Blasting;
 - (b) Pile driving and caisson work;
 - (c) Underpinning;
 - (d) Risks associated with the activities of the Contractor on an active airport;
 - (e) Radioactive contamination resulting from the use of commercial isotopes;
 - (f) Damage to the portion of an existing building beyond that directly associated with an addition, renovation or installation contract; and
 - (g) Marine risks associated with the construction of piers, wharves and docks.

GC10.5.4 Deductible

- 1) The policy shall be issued with a deductible amount of not more than \$10,000 per occurrence applying to Property Damage claims only.

GC10.6 BUILDER'S RISK - INSTALLATION FLOATER - ALL RISKS

GC10.6.1 Scope of Policy

- 1) The policy shall be written on an "All Risks" basis granting coverage similar to those provided by the forms known and referred to in the insurance industry as "Builder's Risk Comprehensive Form" or "Installation Floater - All Risks".

GC10.6.2 Insured

- 1) Each insurance policy shall insure the Contractor, and shall include, as an Additional Insured, Her Majesty the Queen in right of Canada, represented by the Minister of Environment Canada.

GC10.6.3 Property Insured

- 1) The property insured shall include
 - (a) the Work and all property, equipment and materials intended to become part of the finished Work at the site of the Work while awaiting, during and after installation, erection or construction including testing; and
 - (b) expenses incurred in the removal from the construction site of debris of the property insured, including demolition of damaged property, de-icing and dewatering, occasioned by loss, destruction or damage to such property and in respect of which insurance is provided by this policy.

GC10.6.4 Proceeds

- 1) The policy shall provide that proceeds from the policy shall be payable in accordance with GC10.7 INSURANCE PROCEEDS.
- 2) The Contractor shall do such things and execute such documents as are necessary to effect payment of the proceeds.

7 SECTION 7
CONTRACT DOCUMENTS – Appendix “C” General Conditions (GC)

GC10.6.5 Amount of Insurance

- 1) The amount of insurance shall not be less than the sum of the Contract value plus the declared value (if any) set forth in the Contract Documents of all Material and equipment supplied by Canada at the site of the Project to be incorporated into and form part of the finished Work.

GC10.6.6 Deductible

- 1) The policy shall be issued with a deductible amount of not more than \$10,000.

GC10.6.7 Subrogation

- 1) The following provision shall be included in the policy:

"All rights of subrogation or transfer of rights are hereby waived against any corporation, firm, individual or other interest, with respect to which insurance is provided by this policy".

GC10.6.8 Exclusion Qualifications

- 1) The policy may be subject to the standard exclusions but the following qualifications shall apply to the following:
 - (a) faulty materials, workmanship or design may be excluded only to the extent of the cost of making good thereof and shall not apply to loss or damage resulting therefrom;
 - (b) loss or damage caused by contamination by radioactive material may be excluded except for loss or damage resulting from commercial isotopes used for industrial measurement, inspection, quality control radiographic or photographic use; and
 - (c) use and occupancy of the Project or any part or section thereof shall be permitted if such use and occupancy is for the purposes for which the Project is intended upon completion.

GC10.7 INSURANCE PROCEEDS

- 1) In the case of a claim payable under a Builders Risk/Installation Floater (All Risks) insurance contract maintained by the Contractor pursuant to GC10.6 BUILDER'S RISK - INSTALLATION FLOATER - ALL RISKS, the proceeds of the claim shall be paid directly to Canada, and
 - (a) the monies so paid shall be held by Canada for the purposes of the Contract; or
 - (b) if Canada elects, shall be retained by Canada, in which event they vest in Canada absolutely.
- 2) In the case of a claim payable under a General Liability insurance contract maintained by the Contractor pursuant to GC10.5 COMMERCIAL GENERAL LIABILITY, the proceeds of the claim shall be paid by the insurer directly to the claimant.
- 3) If an election is made pursuant to subparagraph 1)(b), Canada may cause an audit to be made of the accounts of the Contractor and of Canada in respect of the part of the Work that was lost, damaged or destroyed for the purpose of establishing the difference, if any, between
 - (a) the aggregate of the amount of the loss or damage suffered or sustained by Canada, and any other amount that is payable by the Contractor to Canada under the Contract, minus any monies retained pursuant to subparagraph 1)(b) herein; and
 - (b) the aggregate of the amounts payable by Canada to the Contractor pursuant to the Contract up to the date of the loss or damage.
- 4) A difference that is established pursuant to paragraph 3) shall be paid forthwith by the party who is determined by the audit to be the debtor to the party who is determined by the audit to be the creditor.
- 5) When payment of a deficiency has been made pursuant to paragraph 4), all rights and obligations of Canada and the Contractor under the Contract shall, with respect only to the part of the Work that was the subject of the audit referred to in paragraph 3), be deemed to have been expended and discharged.

7 SECTION 7
CONTRACT DOCUMENTS – Appendix “C” General Conditions (GC)

- 6) Subject to paragraph 7), if an election is not made pursuant to subparagraph 1)(b), the Contractor, at the Contractor's expense, shall clear and clean the Work and its site and restore and replace the part of the Work that was lost, damaged or destroyed as if that part of the Work had not yet been performed.
- 7) When the Contractor clears and cleans the Work and its site and restores and replaces the Work referred to in paragraph 6), Canada shall pay the Contractor out of the monies referred to in paragraph 1) so far as they will thereunto extend.
- 8) Subject to paragraph 7), payment by Canada pursuant to paragraph 7) shall be made in accordance with the Contract but the amount of each payment shall be 100% of the amount claimed notwithstanding paragraph 3) of GC5.4 PROGRESS PAYMENT.

**7 SECTION 7
CONTRACT DOCUMENTS – Appendix “C” General Conditions (GC)**

INSURER’S CERTIFICATE OF INSURANCE (to be completed by Insurer (not broker) and delivered to Environment Canada within 30 days following acceptance of tender)

CONTRACT

Description of Work _____ Contract No. _____ Award Date _____

Location _____

INSURER

Name _____

Address _____

BROKER

Name _____

Address _____

INSURED

Name of Contractor _____

Address _____

ADDITIONAL INSURED

Her Majesty the Queen in right of Canada as represented by the Minister of Environment Canada

Address _____

This document certifies that the following policies of insurance are at present in force covering all operations of the Insured, in connection with the contract made between the named insured and Environment Canada:

POLICY

Type	Number	Inception Date	Expiry Date	Limit of Liability	Deductible
Commercial General Liability					
Builder’s Risk “All Risks”					
Installation Floater “All Risks”					
Other (list)					

Each of these policies includes coverages/provisions as specified in the Insurance Coverage Requirements in this document which form part of this contract and each policy has been endorsed to cover Her Majesty as an Additional Insured. The Insurer agrees to notify Her Majesty and the Named Insured in writing thirty (30) days prior to any material change in, or cancellation of any policy or coverage.

Name of Insurer’s Officer or Authorized Employee _____ Telephone Number _____

Signature _____ Date _____

ISSUANCE OF THIS CERTIFICATE SHALL NOT LIMIT OR RESTRICT THE RIGHT OF ENVIRONMENT CANADA TO REQUEST AT ANY TIME DUPLICATE CERTIFIED COPIES OF SAID INSURANCE POLICIES.

7 SECTION 7
CONTRACT DOCUMENTS – Appendix “C” General Conditions (GC)

GC11 LABOUR CONDITIONS - R0203D (2004-05-14)

GC11.1 Interpretation

In these conditions

- a. "Act" means the *Fair Wages and Hours of Labour Act*;
- b. "Regulations" means the *Fair Wages and Hours of Labour Regulations* made pursuant to the Act;
- c. "contract" means the contract of which these Labour Conditions are part;
- d. "contracting authority" means the department of Government or a crown corporation with whom the contract is made;
- e. "contractor" means the person who has entered into the contract with the contracting authority;
- f. "regional director" means the director of a regional office of the Department of Human Resources Development or the director's designated representative;
- g. "inspector" has the meaning assigned to the term by Part III of the *Canada Labour Code*.
- h. "Minister" means the Minister of Labour of Canada;
- i. "persons" means those workers employed by the contractor, subcontractor or any other person doing or contracting to do the whole or any part of the work contemplated by the contract;

GC11.2 General Fair Wage Clause

- 1) All persons in the employ of the contractor, subcontractor, or any other person doing or contracting to do the whole or any part of the work contemplated by the contract, shall during the continuance of the work:
 - i. be paid fair wages that is, such wages as are generally accepted as current for competent workers in the district in which the work is being performed for the character or class of work in which such workers are respectively engaged; and
 - ii. in all cases, be paid no less than the minimum hourly rate of pay established by the Labour Program of the Department of Human Resources Development in the Fair Wage Schedules which form a part of this contract as Appendix A to these Labour Conditions; and
 - iii. for contracts covering work performed in the province of Quebec, be paid at least the wage rates established by that province for the purposes of the Quebec "*Construction Decree*".
- 2) Where there is no wage rate in the schedules referred to in (a) for a particular character or class of work, the contractor shall pay wages for that character or class of work at a rate not less than the rate for an equivalent character or class of work.
- 3) Where during the term of the contract, the contractor receives notice from the contracting authority of any change in wage rates, the contractor shall pay not less than the changed wage rate beginning on the first day after receipt, by the contractor, of the notice of the change in wage rates.

GC11.3 Hours of Work

- 1) The hours of work in a day and in a week of persons employed in the execution of the contract, including the hours of work in excess of which a person shall be paid overtime at a rate at least equal to one and one half times the fair wage, are the hours of work for the province in which the work is being performed as set out from time to time in an Act of that province.

7 SECTION 7
CONTRACT DOCUMENTS – Appendix “C” General Conditions (GC)

- 2) The daily or weekly hours of work referred to in paragraph (a) may be exceeded in accordance with the applicable provincial law.

GC11.4 Labour Conditions to be Posted

- 1) For the information and the protection of all persons, the contractor agrees to post and keep posted, in a conspicuous place on the premises where work contemplated by the contract is being carried out or on premises occupied or used by persons engaged in carrying out such work, a copy of these Labour Conditions, and a copy of the applicable Fair Wage Schedules along with any subsequent changes.

GC11.5 Contractor Records Kept Open for Inspection

- 1) The contractor agrees to keep books and records showing the names, addresses, classifications of employment and work of all workers employed under the contract, the rate of wages to be paid, the wages paid and the daily hours worked by the workers.
- 2) The contractor also agrees that the contractor's books, records and premises will be open at all reasonable times for inspection by an inspector.
- 3) The contractor also agrees to furnish the inspector and the contracting authority, on request, with such further information as is required to ascertain that the requirements of the Act, the Regulations and the contract with respect to wages, hours of work and other labour conditions have been complied with.

GC11.6 Departmental Requirements before Payment made to Contractor

- 1) The contractor agrees that the contractor will not be entitled to payment of any money otherwise payable under the contract until the contractor has filed with the contracting authority in support of a claim for payment a sworn statement:
 - i. that the contractor has kept the books and records required by these Regulations,
 - ii. that there are no wages in arrears in respect of work performed under the contract, and
 - iii. that to the contractor's knowledge, all the conditions in the contract required by the Act and the Regulations have been complied with.
- 2) The contractor also agrees that, where fair wages have not been paid by the contractor to persons employed under the contract, the contracting authority shall withhold from any money otherwise payable under the contract to the contractor the amount necessary to ensure that fair wages are paid to all employees until fair wages are paid.

GC11.7 Authority to pay Wages in the Event of Default by the Contractor

- 1) The contractor agrees that where the contractor is in default of payment of fair wages to an employee, the contractor will pay the Minister the amount the contractor is in default.
- 2) The contractor agrees that where the contractor fails to comply with paragraph (1) GC 11.7, the contracting authority will pay to the Receiver General, out of any money otherwise payable to the contractor, the amount for which the contractor is in default.

GC11.8 Conditions of Subcontracting

- 1) The contractor and the subcontractor agree that in subcontracting any part of the work contemplated by the contract, they will place in the subcontract the conditions respecting fair wages, hours of work and other labour conditions set out in the contract and the requirements set out in Section 4. The contractor further agrees that the contractor will be responsible for carrying out these conditions in the event the subcontractor fails to carry them out.

7 SECTION 7
CONTRACT DOCUMENTS – Appendix “C” General Conditions (GC)

GC11.9 Non-discrimination in Hiring and Employment of Labour

- 1) The contractor agrees that in the hiring and employment of workers to perform any work under the contract, the contractor will not refuse to employ and will not discriminate in any manner against any person because
 - a. of that person's race, national or ethnic origin, colour, religion, age, sex, sexual orientation, marital status, disability, conviction for which a pardon has been granted, or family status;
 - b. of the race, national or ethnic origin, colour, religion, age, sex, sexual orientation, marital status, disability, conviction for which a pardon has been granted, or family status of any person having a relationship or association with that person, or
 - c. a complaint has been made or information has been given in respect of that person relating to an alleged failure by the contractor to comply with subparagraph (a) or (b).

GC11.10 Schedule of Fair Wages

- 1) Fair Wage Schedules for Federal Construction Contracts form part of the Contract by Reference and may be accessed from the web site located at:
http://info.load-otea.hrhc-drhc.GC.ca/fair_wages/schedules.shtml.
- 2) Tenderers should note that, in the event of a resultant contract, a copy of the Fair Wage Schedule applicable to the project location and the Fair Wages and Hours of Labour - Labour Conditions must be posted at the work site in a convenient, easily accessible location.

8 SECTION 8 SUPPLEMENTARY CONDITIONS

Appendix “D” Supplementary conditions

SC1 EMPLOYMENT EQUITY

The Federal Contractors Program for Employment Equity requires that some organizations bidding for federal government contracts make a formal commitment to implement employment equity, as a pre-condition to the validation of their bids. All contractors must check the applicable box(e)s below.

Program requirements do not apply for the following reason(s):

- this organization has less than 100 permanent part-time and/or full-time employees;
- this organization is a federally regulated employer;

or, program requirements do apply:

- copy of signed Certificate or Commitment is enclosed; or
- Certificate number is _____.

NOTE: The Certificate of Commitment, criteria and other information about the Federal Contractors Program for Employment Equity, are available in the Standard Acquisition Clauses and Conditions (SACC) Manual, Section 2, and on the MERX Bidding System.

Signature

Date

SC2 WORK FORCE REDUCTION PROGRAM

1 Contractors must indicate if the Work Force Reduction Program is applicable to them:

NO _____ YES _____ (if yes, provide details as listed below)

As a result of the recent implementation of various programs to reduce the public service, Contractors must provide information regarding their status as former public servants in receipt of either a lump sum payment or a pension, or both, pursuant to the terms of the Early Departure Incentive (EDI) Program, the Early Retirement Incentive (ERI) Program, the Forces Reduction Program, the Executive Employment Transition Program and any other current and future similar programs implemented by Treasury Board. Therefore, Contractors must make available the following details:

- a) date and amount of lump sum payment incentive;
- b) terms and conditions of the lump sum payment incentive (including termination date);
- c) rate of pay on which the lump sum payment was based;
- d) whether or not the \$5,000 exemption has been reached.

In the event that a contract is awarded to a former public servant during the period covered by the lump sum payment, the contract fee must be abated (reduced) by an amount corresponding to the number of weeks remaining in the Contractor’s lump sum payment period after the beginning of the contract.

This reduction is subject to an exemption of a maximum of \$5,000 (including GST) applicable to one or more contracts during the period covered by the lump sum payment.

For the purposes of this contract, former public servants is defined as:

- a) an individual;
- b) an individual who has incorporated;
- c) a partnership made up of former public servants; or
- d) a sole proprietorship or entity where the affected individual has a major interest in the entity.

SC3 INTELLECTUAL PROPERTY - CONTRACTOR OWNS IP

1 Definitions and Interpretation

"Subcontract" includes a Contract issued by any subcontractor at any tier for the performance or supply of a part of the Work;

"Background Information" means all Technical Information that is not Foreground Information and that is proprietary to or the confidential information of the Contractor, its Subcontractors or any other supplier of the Contractor;

"Commercial Exploitation in Competition with the Contractor" does not include exploitation by Canada or by any contractor where the good or service produced through such exploitation is for end use by Canada, nor does it include dissemination or distribution by Canada to persons or to other governments at or below cost of any good or service delivered under the Contract or produced through such exploitation;

"Firmware" means any computer program stored in integrated circuits, read-only memory or other similar devices;

"Foreground Information" means any Invention first conceived, developed or reduced to practice as part of the Work under the Contract and all other Technical Information conceived, developed or produced as part of the Work under the Contract;

"Intellectual Property Right" means any intellectual property right recognized by the law, including any intellectual property right protected through legislation (such as that governing patents, copyright, industrial design, integrated circuit topography, or plant breeders' rights) or arising from protection of information as a trade secret or as confidential information;

"Invention" means any new and useful art, process, machine, manufacture or composition of matter, or any new and useful improvement in any art, process, machine, manufacture or composition of matter, whether or not patentable;

"Software" means any computer program whether in source or object code (including Firmware), any computer program documentation recorded in any form or upon any medium, and any computer database, and includes modifications to any of the foregoing;

"Technical Information" means all information of a scientific, technical, or artistic nature relating to the Work, whether oral or recorded in any form or medium and whether or not subject to copyright, including but not limited to any Inventions, designs, methods, processes, techniques, know-how, models, prototypes, patterns, samples, schematics, experimental or test data, reports, drawings, plans, specifications, photographs, collections of information, manuals and any other documents, and Software as well as data-processing printed papers form, notes of design, calculations, files of CADD (computer-assisted programs for design and drawing) and other data, information and documents prepared, calculated, drawn or produced within the framework of the project. Technical Information does not include data concerned with the administration of the Contract by Canada or the Contractor, such as internal financial or management information, unless it is a deliverable under the Contract.

2 Disclosure of Foreground Information

2.1. The Contractor shall promptly report and fully disclose to the Minister all Foreground Information that could be Inventions, and shall report and fully disclose to the Minister all other Foreground Information not later than the time of completion of the Work or such earlier time as the Minister or the Contract may require.

2.2. The Contractor shall, in each disclosure under this section, indicate the names of all Subcontractors at any tier, if any, in which Intellectual Property Rights to any Foreground Information have vested or will vest.

2.3. Before and after final payment to the Contractor, the Minister shall have the right to examine all records and

8 SECTION 8
CONTRACT DOCUMENTS – Appendix “D” Supplementary Conditions (SC)

supporting data of the Contractor which the Minister reasonably deems pertinent to the identification of Foreground Information.

3 Contractor to Own Intellectual Property Rights in Foreground Information

3.1. Subject to subsection 3 and section 7 (Transfer of Intellectual Property Rights in Foreground Information), and without affecting any Intellectual Property Rights or interests therein that have come into being prior to the Contract or that relate to information or data supplied by Canada for purposes of the Contract, all Intellectual Property Rights in the Foreground Information shall immediately, as soon as they come into existence, vest in and remain the property of the Contractor.

3.2. Notwithstanding the Contractor's ownership of the Intellectual Property Rights in Foreground Information that is a prototype, model or custom or customized system or equipment together with associated manuals and other operating and maintenance documents and tools, Canada shall have unrestricted ownership rights in those deliverables, including the right to make them available for public use, whether for a fee or otherwise, and, except in the case of Software that is not necessary for the operation of the prototype, model or system or equipment, the right to sell them.

4 License to Intellectual Property Rights in Foreground Information

4.1. In consideration of Canada's contribution to the cost of development of the Foreground Information, the Contractor hereby grants to Canada a non-exclusive, perpetual, irrevocable, world-wide, fully-paid and royalty-free license to exercise all Intellectual Property Rights in the Foreground Information that vest in the Contractor for any public purpose except Commercial Exploitation in Competition with the Contractor. The Intellectual Property Rights arising from any modification, improvement, development or translation of the Foreground Information that is effected by or for Canada in the exercise of this license shall vest in Canada, or in such person as Canada shall decide.

4.2. The Contractor acknowledges that Canada may wish to award contracts for any of the purposes contemplated in subsection 4.1 and that such contract awards may follow a competitive process. The Contractor agrees that Canada's license in relation to the Intellectual Property Rights in the Foreground Information that vest in the Contractor pursuant to section 3 (Contractor to own Intellectual Property), includes the right to disclose the Foreground Information to bidders for such contracts, and to sub-license or otherwise authorize the use of that information by any contractor engaged by Canada solely for the purpose of carrying out such a contract. Canada shall require the bidder or the contractor not to use or disclose any Foreground Information except as may be necessary to bid for or to carry out that contract.

4.3. Where the Intellectual Property Rights in any Foreground Information are or will be owned by a Subcontractor at any tier, the Contractor shall either obtain a license from that Subcontractor or arrange for the Subcontractor to convey directly to Canada the same rights by execution of the form provided for that purpose by the Minister, in which case the Contractor shall deliver that form to the Minister, duly completed and executed by the Subcontractor, no later than the time of disclosure to Canada of that Foreground Information.

5 License to Intellectual Property Rights in Background Information

5.1. Without restricting the scope of any licence to exercise the Intellectual Property Rights in the Background Information that Canada may otherwise hold, the Contractor hereby grants to Canada a non-exclusive, perpetual, irrevocable, world-wide, fully-paid and royalty-free license to exercise such of the Intellectual Property Rights in any Background Information incorporated into the Work or necessary for the performance of the Work as may be required for the following purposes:

- (a) for the use, operation, maintenance, repair or overhaul of the Work;
- (b) in the manufacturing of spare parts for maintenance, repair or overhaul of any custom part of the Work by Canada if those parts are not reasonably available to enable timely maintenance, repair or overhaul;
- (c) for disclosure to any contractor engaged by Canada (or bidder for such a contract) to be used solely for a purpose set out in paragraph (a) or (b), but only if the Contractor is unable or unwilling to carry out the maintenance, repair or overhaul or provide the spare parts on reasonable commercial terms and within

reasonable delivery times;
and the Contractor agrees to make any such Background Information (including, in the case of Software, source code) promptly available to Canada for any such purpose.

5.2. The Contractor hereby further grants to Canada a non-exclusive, perpetual, irrevocable, world-wide, fully-paid and royalty-free license to exercise Intellectual Property Rights in the Background Information incorporated into the Work or necessary in order for Canada to modify, improve or further develop the Foreground Information. Canada's rights under this subsection 2 shall not include the right to reproduce the whole or part of any deliverable under the Contract that does not incorporate Foreground Information. The Contractor agrees to make any such Background Information (including, in the case of Software, source code) promptly available to Canada for any such purpose.

6 Right to License

The Contractor represents and warrants that the Contractor has, or the Contractor undertakes to obtain, the right to grant to Canada the license to exercise the Intellectual Property Rights in the Foreground Information and the Background Information as required by the Contract.

7 Transfer of Intellectual Property Rights in Foreground Information

7.1. Until the Contractor completes the Work and discloses all of the Foreground Information in accordance with section 2 (Disclosure of Foreground Information), the Contractor shall not, without the prior written permission of the Minister, sell, assign or otherwise transfer title to the Intellectual Property Rights in any Foreground Information, or license or otherwise authorize the use of the Intellectual Property Rights in any of the Foreground Information by any person.

7.2. If Canada terminates the Contract in whole or in part for default, or if the Contractor fails to disclose any Foreground Information in accordance with section 2, the Minister may, by notice given not later than 90 days from the date of termination or from the date Canada learns of the failure to disclose, require the Contractor to convey to Canada all of the Intellectual Property Rights in the Foreground Information that have vested or are to vest in a Subcontractor at any tier. In the case of Intellectual Property Rights in Foreground Information which have been sold or assigned to a party other than a Subcontractor at any tier, the Contractor shall not be obligated to convey rights to Canada in accordance with this subsection, but shall pay to Canada on demand an amount equal to the consideration which the Contractor received from the sale or assignment of the Intellectual Property Rights in that Foreground Information.

7.3. In the event of the issuance by the Minister of a notice under subsection 2, the Contractor shall, at its own expense and without delay, execute such conveyances or other documents relating to title to the Intellectual Property Rights as the minister for whose department or agency the Work is being carried out may require, and the Contractor shall, at Canada's expense, afford that minister all reasonable assistance in the preparation of applications and in the prosecution of any applications for, or any registration of, any Intellectual Property Right in any jurisdiction, including without limitation the assistance of the inventor in the case of Inventions.

8 Sale, Assignment, Transfer or Licensing of Intellectual Property Rights in the Foreground Information

8.1. In any sale, assignment, transfer or license of Intellectual Property Rights in Foreground Information by the Contractor except a sale or license for end use of a product based on Foreground Information, the Contractor shall impose on the other party all of its obligations to Canada in relation to the Intellectual Property Rights in the Foreground Information and any restrictions set out in the Contract on the use or disposition of the Intellectual Property Rights in the Foreground Information (and, if applicable, the Foreground Information), including the obligation to impose the same obligations and restrictions on any subsequent transferee, assignee or licensee.

8.2. The Contractor shall promptly notify Canada of the name, address and other pertinent information in regard to any transferee, assignee or licensee referred to in subsection 8.1, and shall ensure that such party is required to do the same with regard to any subsequent transferee, assignee or licensee.

8 SECTION 8
CONTRACT DOCUMENTS – Appendix “D” Supplementary Conditions (SC)

8.3. The Contractor shall not charge or permit any person to charge a royalty or other fee to Canada in respect of the Intellectual Property Rights in any Foreground Information for purposes of a contract or other arrangement with Canada.

9 Access to Information; Exception to Contractor Rights

9.1. Subject to the *Access to Information Act*, R.S.C., c. A-1 and to any right of Canada under the Contract, Canada shall not release or disclose outside the Government of Canada any information delivered to Canada under the Contract that is confidential information or a trade secret of the Contractor or a Subcontractor.

10 Waiver of Moral Rights

10.1. The Contractor shall obtain a written permanent waiver of moral rights (as this term is defined in the *Copyright Act*, R.S.C., c. C-42), in a form acceptable to the Minister, from every author that contributes to any Foreground Information which is subject to copyright protection and which is deliverable to Canada under the terms of the Contract. At the request of the Minister (be it at the completion of the Work or at any other time as the Minister may require), the Contractor shall provide the written waiver(s) of moral rights to the Minister.

10.2. If the Contractor is an author of the Foreground Information referred to in subsection 1, the Contractor hereby permanently waives the Contractor's moral rights in that Foreground Information.

SC4 INTERNATIONAL SANCTIONS

1.1 Canada imposes restrictions on trade, financial transactions or other dealings with a foreign country or its nationals. As a result, the Government of Canada cannot accept delivery of goods or services that originate, either directly or indirectly, from the countries subject to economic sanctions. Details on existing sanctions can be found at: <http://www.dfait-maeci.gc.ca/trade/sanctions-e.asp>
These sanctions may be implemented by regulation under the United Nations Act (UNA), R.S.C.1985 c. U-2, The Special Economic Measures Act (SEMA), R.S.C. 1992, c. 17, or the Export or Import Permits Act (EIPA), R.S.C. 1985, c. E-19.

1.2. The Contractor agrees to comply with any such regulations in effect during the life of the contract, and will inform its subcontractors of the existence of the regulations in force at the time of contract award. In the event that such regulation preventing the Contractor from performing all or part of its obligations, the Contractor shall treat the situation as a force majeure, and forthwith inform Canada of the situation and follow the procedure applicable to force majeure.

The Contractor agrees that Canada relies on the Contractor's undertaking in subsection 1.1, to enter into the Contract, and that any breach of the undertaking shall entitle Canada to terminate the contract under the provisions of the contract relating to default by the Contractor, and therefore to recover damages from the Contractor, including re-procurement costs arising out of such a termination.

9 SECTION 9
LIST OF TENDER SPECIFICATIONS, PLANS AND DRAWINGS

9 SECTION 9 LIST OF SPECIFICATIONS AND DRAWINGS

N°	Titre	Date
101	FE-PUMPING STATION, 5365 HWY 96, Wolfe Island (On)	June 23, 2014
201	FE-PUMPING STATION, 5365 HWY 96, Wolfe Island (On)	June 23, 2014
301	FE-PUMPING STATION, 5365 HWY 96, Wolfe Island (On)	June 23, 2014
401	FE-PUMPING STATION, 5365 HWY 96, Wolfe Island (On)	June 23, 2014
501	FE-PUMPING STATION, 5365 HWY 96, Wolfe Island (On)	June 23, 2014

SPECIFICATIONS

SUMMARY OF WORK - 01 11 00

PART 1 - GENERAL

1.1 WORK COVERED BY CONTRACT DOCUMENTS

1. Work of this Contract comprises of building a modular building, to replace an old trailer at a river side location. The contractor is responsible to: install pier foundations and deliver and install the prefabricated building and reconnect to On-site existing services.
2. The new building is to be built off site and delivered as a completed structure.
3. The existing services to the Well House will need disconnected and reconnected.
4. Obtain all permits and approvals required to perform work outlined in documents.

1.2 WORK SEQUENCE

1. Co-ordinate Progress Schedule and co-ordinate with Owner for construction.

1.3 OWNER FURNISHED ITEMS

1. Owner Responsibilities:
 1. Provide and Install Air Conditioning unit.
2. Contractor Responsibilities:
 1. Size and prepare opening for unit, confirm.

1.4 EXISTING SERVICES

1. Notify, Owner and utility companies of intended interruption of services and obtain required permission.
2. Where Work involves breaking into or connecting to existing services, give Owner 48 hours notice for necessary interruption of mechanical or electrical service throughout course of work. Minimize duration of interruptions. Carry out work at times as directed by governing authorities with minimum disturbance to [pedestrian] [vehicular traffic] [and] [tenant operations].
3. Where unknown services are encountered, immediately advise Owner and confirm findings in writing.
4. Protect, relocate or maintain existing active services. When inactive services are encountered, cap off in manner approved by authorities having jurisdiction.
5. Record locations of maintained, re-routed and abandoned service lines.

1.5 ALLOWANCES

1. \$4000 to obtain building permit.

SUBMITTAL PROCEDURE - 01 33 00

PART 1 - GENERAL

1.1 ADMINISTRATIVE

1. Submit Owner submittals listed for review. Submit promptly and in orderly sequence to not cause delay in Work. Failure to submit in ample time is not considered sufficient reason for extension of Contract Time and no claim for extension by reason of such default will be allowed.
2. Do not proceed with Work affected by submittal until review is complete.
3. Present shop drawings, product data, samples and mock-ups in SI Metric units.
4. Review submittals prior to submission to Owner. This review represents that necessary requirements have been determined and verified, or will be, and that each submittal has been checked and co-ordinated with requirements of Work and Contract Documents. Submittals not stamped, signed, dated and identified as to specific project will be returned without being examined and considered rejected.
5. Notify Owner, in writing at time of submission, identifying deviations from requirements of Contract Documents stating reasons for deviations.
6. Verify field measurements and affected adjacent work.
7. Contractor's responsibility for errors and omissions in submission is not relieved by Owners review of submittals.
8. Keep one reviewed copy of each submission on site.

1.2 SHOP DRAWINGS AND PRODUCT DATA

1. The term "shop drawings" means drawings, diagrams, illustrations, schedules, performance charts, brochures and other data which are to be provided by Contractor to illustrate details of a portion of Work.
2. Indicate materials, methods of construction and attachment or anchorage, erection diagrams, connections, explanatory notes and other information necessary for completion of Work. Where articles or equipment attach or connect to other articles or equipment, indicate that such items have been co-ordinated, regardless of Section under which adjacent items will be supplied and installed. Indicate cross references to design drawings and specifications.
3. Allow 10 days for Owner review of each submission.
4. Adjustments made on shop drawings by Owner are not intended to change Contract Price. If adjustments affect value of Work, state such in writing to Owner prior to proceeding with Work.
5. Make changes in shop drawings as Owner may require, consistent with Contract Documents. When resubmitting, notify Owner in writing of revisions other than those requested.
6. Submit 4 prints of shop drawings for each requirement requested in specification Sections and as Owner may reasonably request.
7. Certificates must be dated after award of project contract complete with project name.

8. Supplement standard information to provide details applicable to project.
9. The review of shop drawings by Public Works and Government Services Canada (PWGSC) is for sole purpose of ascertaining conformance with general concept.
 1. This review shall not mean that PWGSC approves detail design inherent in shop drawings, responsibility for which shall remain with Contractor submitting same, and such review shall not relieve Contractor of responsibility for errors or omissions in shop drawings or of responsibility for meeting requirements of construction and Contract Documents.
 2. Without restricting generality of foregoing, Contractor is responsible for dimensions to be confirmed and correlated at job site, for information that pertains solely to fabrication processes or to techniques of construction and installation and for co-ordination of Work of sub-trades.

1.3 PHOTOGRAPHIC DOCUMENTATION

1. Submit electronic copy of colour digital photography in jpg format, min 1600x1900 resolution, as directed Owner.
2. Project identification: name and number of project and date of exposure indicated.
3. Upon completion of: excavation, foundation, framing and all services before concealment of Work, and as directed by Owner.

HEALTH AND SAFETY REQUIREMENTS - 01 35 29

PART 1 - GENERAL

1.1 REFERENCES

1. Canada Labour Code, Part 2, Canada Occupational Safety and Health Regulations
2. Health Canada/Workplace Hazardous Materials Information System (WHMIS) Material Safety Data Sheets (MSDS).
3. Province of Ontario
 1. Occupational Health and Safety Act, R.S.O. [1990 Updated 2005].

1.2 ACTION AND INFORMATIONAL SUBMITTALS

1. Make submittals in accordance with Section [01 33 00 - Submittal Procedures].
2. Submit site-specific Health and Safety Plan: Within 7 days after date of Notice to Proceed and prior to commencement of Work. Health and Safety Plan must include:
 1. Results of site specific safety hazard assessment.
 2. Results of safety and health risk or hazard analysis for site tasks and operation.
 3. Submit 1 copy of Contractor's authorized representative's work site health and safety reports to Departmental Representative.
 4. Submit copies of incident and accident reports.
3. Owner's review of Contractor's final Health and Safety plan should not be construed as approval and does not reduce the Contractor's overall responsibility for construction Health and Safety.

1.3 FILING OF NOTICE

1. File Notice of Project with Provincial authorities prior to beginning of Work.

1.4 MEETINGS

1. Schedule and administer Health and Safety meeting with Owner prior to commencement of Work.

1.4 GENERAL REQUIREMENTS

1. Develop written site-specific Health and Safety Plan based on hazard assessment prior to beginning site Work and continue to implement, maintain, and enforce plan until final demobilization from site. Health and Safety Plan must address project specifications.
2. Owner may respond in writing, where deficiencies or concerns are noted and may request re-submission with correction of deficiencies or concerns.

1.5 RESPONSIBILITY

1. Be responsible for health and safety of persons on site, safety of property on site and for protection of persons adjacent to site and environment to extent that they may be affected by conduct of Work.
2. Comply with and enforce compliance by employees with safety requirements of Contract Documents, applicable federal, provincial, territorial and local statutes, regulations, and ordinances, and with site-specific Health and Safety Plan.

1.6 COMPLIANCE REQUIREMENTS

1. Comply with Ontario Health and Safety Act, R.S.O.

1.7 POSTING OF DOCUMENTS

1. Ensure applicable items, articles, notices and orders are posted in conspicuous location on site in accordance with Acts and Regulations of Province having jurisdiction, and in consultation with Owner.

1.8 CORRECTION OF NON-COMPLIANCE

1. Immediately address health and safety non-compliance issues identified by authority having jurisdiction or by Owner.

2. Provide Owner with written report of action taken to correct non-compliance of health and safety issues identified.
3. Owner may stop Work if non-compliance of health and safety regulations is not corrected.

ENVIRONMENTAL PROCEDURES - 01 35 43

PART 1 - GENERAL

1.1 ACTION AND INFORMATIONAL SUBMITTALS

1. Provide submittals in accordance with Section [01 33 00 - Submittal Procedures].
2. Prior to commencing construction activities or delivery of materials to site, provide Environmental Protection Plan for review by Owner.
3. Ensure Environmental Protection Plan includes comprehensive overview of known or potential environmental issues to be addressed during construction.
4. Address topics at level of detail commensurate with environmental issue and required construction tasks.
5. Include in Environmental Protection Plan:
 1. Name[s] of person[s] responsible for ensuring adherence to Environmental Protection Plan.
 2. Drawings showing locations of proposed temporary excavations or embankments for haul roads, stream crossings, material storage areas, structures, sanitary facilities, and stockpiles of excess or spoil materials including methods to control runoff and to contain materials on site.
 3. Spill Control Plan including procedures, instructions, and reports to be used in event of unforeseen spill of regulated substance.
 4. Contaminant Prevention Plan identifying potentially hazardous substances to be used on job site, intended actions to prevent introduction of such materials into air, water, or ground; and detailing provisions for compliance with Federal, Provincial, and Municipal laws and regulations for storage and handling of these materials.

1.2 DRAINAGE

1. Provide Erosion and Sediment Control Plan identifying type and location of erosion and sediment controls provided. Ensure plan includes monitoring and reporting requirements to assure that control measures are in compliance with erosion and sediment control plan, Federal, Provincial, and Municipal laws and regulations, EPA 832/R-92-005, Chapter 3 requirements].
2. Ensure pumped water into waterways, sewer or drainage systems is free of suspended materials.
3. Control disposal or runoff of water containing suspended materials or other harmful substances in accordance with local authority requirements.

1.3 WORK ADJACENT TO WATERWAYS

1. Construction equipment to be operated on land only.
2. Waterways to be free of excavated fill, waste material and debris.
3. Design and construct temporary crossings to minimize erosion to waterways.

CONSTRUCTION FACILITIES - 01 52 00

PART 1 - GENERAL

1.1 REFERENCES

1. Public Works Government Services Canada (PWGSC) Standard Acquisition Clauses and Conditions (SACC)-ID: R0202D, Title: General Conditions 'C', In Effect as of: May 14, 2004.

1.2 INSTALLATION AND REMOVAL

1. Prepare site plan indicating proposed location and dimensions of area to be fenced and used by Contractor, avenues of ingress/egress to fenced area and details of fence installation.
2. Indicate use of supplemental or other staging area.
3. Provide construction facilities in order to execute work expeditiously.
4. Remove from site all such work after use.

1.3 SITE STORAGE/LOADING

1. Confine work and operations of employees by Contract Documents. Do not unreasonably encumber premises with products.

1.4 CONSTRUCTION PARKING

1. Parking will be permitted on site.

1.5 EQUIPMENT, TOOL AND MATERIALS STORAGE

1. Provide and maintain, in clean and orderly condition, lockable weatherproof sheds for storage of tools, equipment and materials.

2. Locate materials not required to be stored in weatherproof sheds on site in manner to cause least interference with work activities.

1.6 SANITARY FACILITIES

1. Provide sanitary facilities for work force in accordance with governing regulations and ordinances.
2. Post notices and take precautions as required by local health authorities. Keep area and premises in sanitary condition.

2. For each product or system, List names, addresses and telephone numbers of subcontractors and suppliers, including local source of supplies and replacement parts.

1.7 CONSTRUCTION SIGNAGE

1. Construction sign of wood frame and plywood construction painted with exhibit lettering produced by a professional sign painter.
2. Indicate on sign, name of Owner, and Contractor.
3. No other signs or advertisements, other than warning signs, are permitted on site.
4. Provide project identification and notices.

TEMPORARY BARRIERS AND ENCLOSURES - 01 56 00

PART 1 - GENERAL

1.1 INSTALLATION AND REMOVAL

1. Provide temporary controls in order to execute Work expeditiously.
2. Remove from site all such work after use.

1.2 HOARDING

1. Erect temporary site enclosure using new 1.8 m high rigid fence. Provide [one] lockable truck gate. Maintain fence in good repair.

1.3 PROTECTION FOR OFF-SITE AND PUBLIC PROPERTY

1. Protect surrounding private and public property from damage during performance of Work.
2. Be responsible for damage incurred.

CLEANING - 01 74 11

PART 1 - GENERAL

1.1 PROJECT CLEANLINESS

1. Maintain Work in tidy condition, free from accumulation of waste products and debris, including that caused by Owner or other Contractors.
2. Remove waste materials from site at daily regularly scheduled times or dispose of as directed by Owner. Do not burn waste materials on site.
3. Make arrangements with and obtain permits from authorities having jurisdiction for disposal of waste and debris.
4. Dispose of waste materials and debris at designated dumping areas off site.
5. Schedule cleaning operations so that resulting dust, debris and other contaminants will not fall on wet, newly painted surfaces nor contaminate building systems.

1.2 FINAL CLEANING

1. When Work is Substantially Performed remove surplus products, tools, construction machinery and equipment not required for performance of remaining Work.
2. Remove stains, spots, marks and dirt from decorative work, electrical and mechanical fixtures, furniture fittings, walls, and floors.
3. Clean lighting reflectors, lenses, and other lighting surfaces.
4. Vacuum clean and dust building interiors, behind grilles, louvers and screens.
5. Wax, seal, shampoo or prepare floor finishes, as recommended by manufacturer.
6. Inspect finishes, fittings and equipment and ensure specified workmanship and operation.
7. Broom clean and wash exterior walks, steps and surfaces; rake clean other surfaces of grounds.
8. Remove dirt and other disfiguration from exterior surfaces.
9. Sweep and wash clean paved areas.

CLOSEOUT SUBMITTALS - 01 78 00

PART 1 - GENERAL

1.1 FORMAT

1. Organize data as instructional manual.
2. Binders: vinyl, hard covered, 3 'D' ring, loose leaf with spine and face pockets.
3. Cover: identify each binder with type or printed title 'Project Record Documents'; list title of project and identify subject matter of contents.
4. Arrange content by systems, under Section numbers and sequence of Table of Contents.
5. Provide tabbed fly leaf for each separate product and system, with typed description of product and major component parts of equipment.
6. Text: manufacturer's printed data, or typewritten data.
7. Drawings: provide with reinforced punched binder tab. Bind in with text; fold larger drawings to size of text pages.
8. Provide CAD files in dwg format on CD.

1.2 CONTENTS - PROJECT RECORD DOCUMENTS

1. Table of Contents for Each Volume: provide title of project:
 1. Date of submission; names.
 2. Addresses, and telephone numbers of Contractor with name of responsible parties.
 3. Schedule of products and systems, indexed to content of volume.



		FE - PUMPING STATION 5365 HWY 96, WOLFE ISLAND, ON	Date/Date Jun 23/14	Environment Canada Property Management District 2	Environnement Canada Gestion de l'immobilier District 2
		DWG.NO.-DESSIN NO.	Scale/Echelle n.t.s.		
Jun 23/14	FOR TENDER	101		CANADA CENTRE FOR INLAND WATERS LE CENTRE CANADIEN DES EAUX INTERIEURES	
Date	REVISION			887 LAKESHORE RD BURLINGTON, ON L7R 4A6	

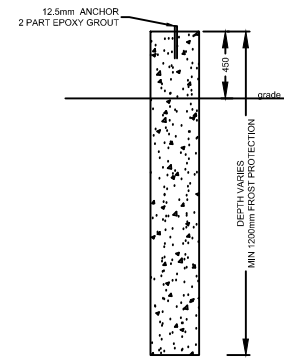

2
201
PIER DETAIL
SCALE: 1:20

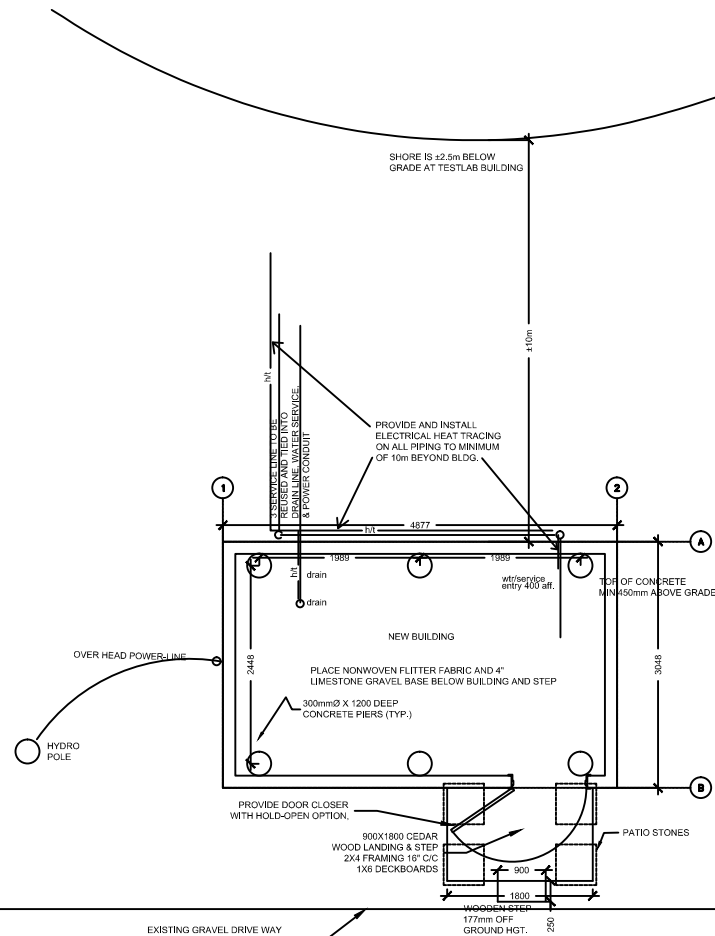

1
201
SITE PLAN
SCALE: 1:20

SPECIFICATIONS

DEMOLITION - 02 41 16

PART 3 - EXECUTION

3.1 PREPARATION

- 1 Do Work in accordance with Section [01 35 29.06 - Health and Safety Requirements].
- 2 Protection:
 - 1 Prevent movement, settlement, or damage to adjacent structures, utilities, to remain in place. Provide bracing and shoring required.
 - 2 Protect building services and equipment.
- 3 Disconnect electrical lines. Post warning signs as required and reconnect to new building when available.

3.2 REMOVAL FROM SITE

- 1 Remove from site existing trailer.

METAL STAIRS - 05 51 29

PART 1 - GENERAL

1.1 REFERENCES

- 2 ASTM A 307-07b, Standard Specification for Carbon Steel Bolts and Studs, 60,000 PSI Tensile Strength.

5 CSA International

- 1 CSA G40.20/G40.21-04, General Requirements for Rolled or Welded Structural Quality Steel/Structural Quality Steel.
- 2 CAN/CSA G164, Hot Dip Galvanizing of Irregularly Shaped Articles.
- 3 CSA W59-03, Welded Steel Construction (Metal Arc Welding).

PART 2 - PRODUCTS

2.1 SYSTEM DESCRIPTION

- 1 Design metal stair, balustrade and landing construction and connections to NBC vertical and horizontal live load requirements.
- 2 Detail and fabricate stairs to NAAMM Metal Stairs Manual.
- 3 Submit stair drawings for review.

2.2 MATERIALS

- 1 Steel sections: to CSA G40.20/G40.21 Grade 300 W.
- 2 Steel plate: to CSA G40.20/G40.21, Grade 260 W.
- 3 Steel tubing: to CSA G40.20/G40.21, Grade 300W.
- 4 Metal bar grating: to ANSINAAMM MBG 531, steel.
- 5 Welding materials: to [CSA W59].
- 6 Bolts: to ASTM A 307.

2.3 FABRICATION

- 1 Fabricate in accordance with NAAMM, Metal Stair Manual.
- 2 Weld connections where possible, otherwise bolt connections. Countersink exposed fasteners, cut off bolts flush with nuts. Make exposed connections of same material, colour and finish as base material on which they occur.
- 3 Accurately form connections with exposed faces flush:
 - 1 Make mitres and joints tight.
 - 2 Make risers of equal height.
- 4 Grind or file exposed welds and steel sections smooth.
- 5 Shop fabricate stairs in sections as large and complete as practicable.

2.4 FINISHES

- 1 Galvanizing: hot dipped galvanizing with zinc coating 600 g/m² to CAN/CSA-G164.

PART 3 - EXECUTION

3.1 EXAMINATION

- 1 Verification of Conditions: verify conditions of substrates previously installed under other Sections or Contracts are acceptable for metal stairs installation in accordance with manufacturer's written instructions.

3.2 INSTALLATION

- 1 Install as shown on drawings.

EARTHWORK - 31 00 00

PART 1 - GENERAL

1.1 REFERENCES

1 ASTM International

- 1 ASTM D 698-[07e1], Standard Test Methods for Laboratory Compaction Characteristics of Soil Using Standard Effort (12,400ft-lbf/ft³) (600kN-m/m³).

2 CSA International

- 1 CSA A23.1/A23.2-[09], Concrete Materials and Methods of Concrete Construction/Test Methods and Standard Practices for Concrete.
- 2 CSA A3000-[08], Cementitious Materials Compendium.

1.2 ACTION AND INFORMATIONAL SUBMITTALS

- 1 Submit testing and inspection results and report as described in PART 3 - FIELD QUALITY CONTROL.

PART 2 - PRODUCTS

2.1 MATERIALS

- 1 Granular A to OPSS 1010.

PART 3 - EXECUTION

3.1 EXAMINATION

- 1 Evaluation and Assessment:
- 2 Before commencing work verify locations of buried services on and adjacent to site.

3.2 PREPARATION

- 1 Provide temporary erosion and sedimentation control measures to prevent soil erosion and discharge of soil-bearing water runoff or airborne dust to adjacent properties and walkways, according to [requirements of authorities having jurisdiction] [sediment and erosion control drawings] [sediment and erosion control plan, specific to site, that complies with EPA 832/R-92-005 or requirements of authorities having jurisdiction, whichever is more stringent].
- 2 Inspect, repair, and maintain erosion and sedimentation control measures during construction until permanent vegetation has been established.
- 3 Remove erosion and sedimentation controls and restore and stabilize areas disturbed during removal.

3.3 EXCAVATION

- 1 Excavate as required to carry out work.
 - 1 Do not disturb soil or rock below bearing surfaces.
- 2 Notify Departmental Representative when excavations are complete.
- 3 If bearings are unsatisfactory, additional excavation will be authorized in writing and paid for as additional work.
- 4 Excavation taken below depths shown without Departmental Representative's written authorization to be filled with concrete of same strength as for footings at Contractor's expense.

3.4 FIELD QUALITY CONTROL

- 1 Testing of materials and compaction will be carried out by testing laboratory designated by Departmental Representative.
- 2 Not later than 48 hours before backfilling or filling with approved material, notify Departmental Representative to allow compaction tests to be carried out by designated testing agency.

3.5 BACKFILLING

- 1 Fill excavated areas with selected subgrade material compacted as specified for fill.

3.6 CLEANING

- 1 Progress Cleaning: clean in accordance with Section [01 74 11 - Cleaning].
 - 1 Leave Work area clean at end of each day.
 - 2 Dispose of cleared and grubbed material off site daily.

SODDING - 32 92 23

PART 1 - GENERAL

1.1 SCHEDULING

- 1 Schedule sod laying to coincide with preparation of soil surface.
- 2 Schedule sod installation when frost is not present in ground.

PART 2 - PRODUCTS

2.1 MATERIALS

- 1 Commercial Grade Turf Grass Nursery : sod that has not been grown as Turf Grass Nursery Sod crop.

2.2 SOURCE QUALITY CONTROL

- 1 Obtain approval from Departmental Representative of sod at source.
- 2 When proposed source of sod is approved, use no other source without written authorization from Departmental Representative.

PART 3 - EXECUTION

3.1 PREPARATION

- 1 Do not perform work under adverse field conditions such as frozen soil, excessively wet soil or soil covered with snow, ice, or standing water.
- 2 Fine grade surfaces free of humps and hollows to smooth, even grade, for Commercial Grade Turf Grass Nursery, surface to drain naturally.
- 3 Remove and dispose of weeds; debris; stones 50 mm in diameter and larger; soil contaminated by oil, gasoline and other deleterious materials; off site in location as directed by Departmental Representative.

3.2 MAINTENANCE DURING ESTABLISHMENT PERIOD

- 1 Perform following operations from time of installation until acceptance.
- 2 Water sodded areas in sufficient quantities and at frequency required to maintain optimum soil moisture condition to depth of [75 to 100] mm.
- 3 Cut grass prior to it reaching height of [75] mm. Remove clippings which will smother grassed areas as directed by Departmental Representative.
- 4 Maintain sodded areas weed free [95%].
- 5 Fertilize areas in accordance with fertilizing program. Spread half of required amount of fertilizer in one direction and remainder at right angles [and water in well].

3.3 ACCEPTANCE

- 1 Sodded Commercial Grade Turf Grass Nursery Sod areas will be accepted by Departmental Representative provided that:
 - 1 Sodded areas are properly established.
 - 2 Extent of surface soil visible when grass has been cut to height of 60 mm is acceptable.
 - 3 Sod is free of bare or dead spots and extent of weeds apparent in grass is acceptable.
 - 4 Sodded areas have been cut minimum 2 times prior to acceptance.
- 2 Areas sodded in fall will be accepted in following spring one month after start of growing season provided acceptance conditions are fulfilled.

3.4 MAINTENANCE DURING WARRANTY PERIOD

- 1 Perform Maintenance operations from time of acceptance until end of warranty period:

		FE - PUMPING STATION 5365 HWY 96, WOLFE ISLAND, ON	Date/Date Jun 23/14	Environment Canada Property Management District 2 Environnement Canada Gestion de l'immobilier District 2
		DWG.NO.-DESSIN NO. 201	Scale/Echelle n.t.s.	
Jun 23/14	FOR TENDER			
Date	REVISION			

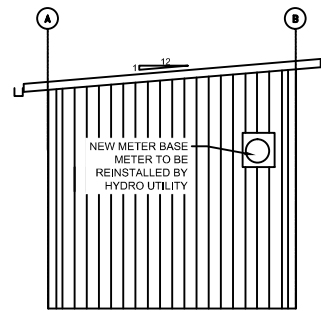

1 EAST ELEVATION
301 SCALE: 1:20

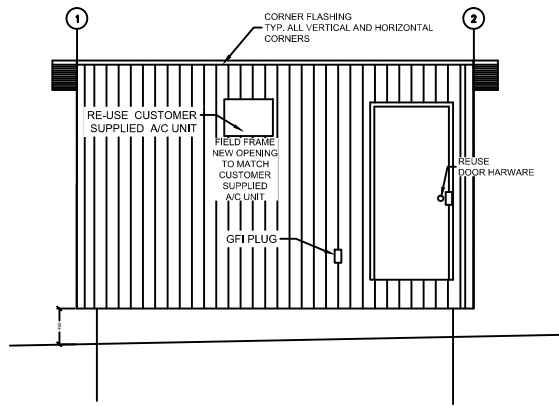

2 NORTH ELEVATION
301 SCALE: 1:20

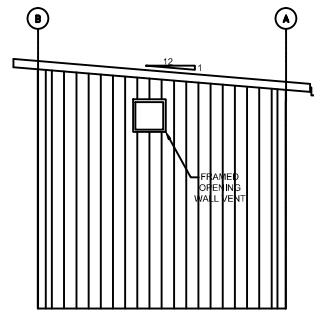

3 WEST ELEVATION
301 SCALE: 1:20

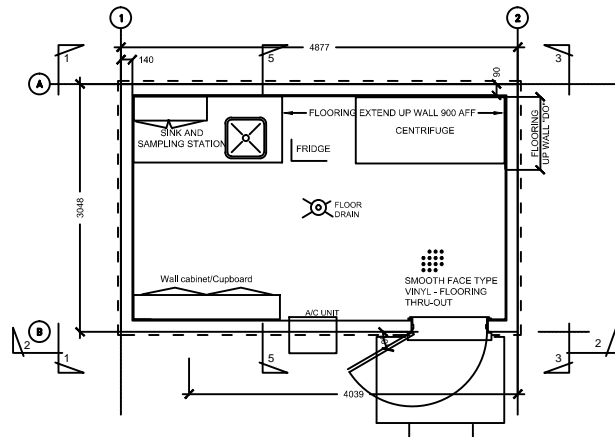

4 FLOOR PLAN
301 SCALE: 1:20

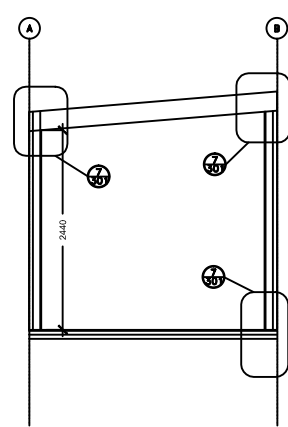

5 CROSS SECTION
301 SCALE: 1:20

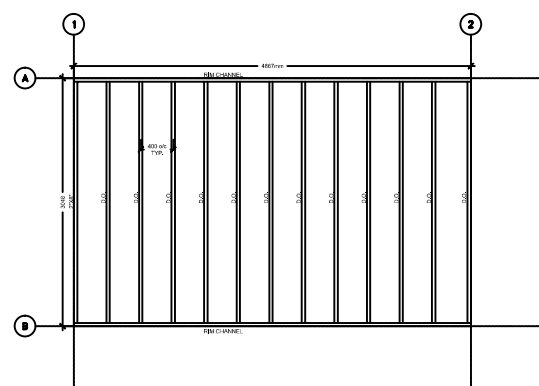

6 ROOF FRAMING
301 SCALE: 1:20

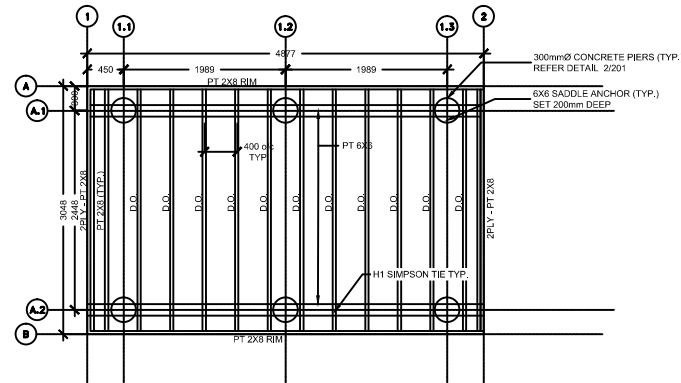

7 FLOOR FRAMING
301 SCALE: 1:20

SPECIFICATIONS

METAL CLADDING - 07 61 00

PART 1 - GENERAL

1.1 REFERENCES

- 1 American Society for Testing and Materials International (ASTM).
 - 1 ASTM A 653/A 653M-[02a], Standard Specification for Steel Sheet, Zinc-Coated (Galvanized) or Zinc-Iron Alloy-Coated (Galvannealed) by the Hot-Dip Process.

1.2 ACTION AND INFORMATIONAL SUBMITTALS

- 1 Submit samples of standard colour selection.

PART 2 - PRODUCTS

2.1 SHEET METAL MATERIALS

- 1 Zinc coated steel sheet: to [ASTM A 653/A 653M], commercial quality, with Z275 coating, prefinished as specified in [2.2].
- 2 Cladding and Roofing: Vicwest 938 - or approved alternative

2.2 PREFINISHED STEEL SHEET

- 1 Prefinished steel with factory applied polyvinylidene fluoride.
 - 1 Class F1S.
 - 2 colour selected by Owner from manufacturer's standard range.
 - 3 Specular gloss: 30 units +/- 5 in accordance with ASTM D523.
 - 4 Coating thickness: not less than 22 micrometres.
 - 5 Resistance to accelerated weathering for chalk rating of 8, colour fade 5 units or less and erosion rate less than 20% to ASTM D 822:
 - 1 Outdoor exposure period 2500 hours.
 - 2 Humidity resistance exposure period 5000 hours.

2.3 ACCESSORIES

- 1 Cleats: of same material, and temper as sheet metal, minimum 50mm wide. Thickness same as sheet metal being secured.
- 2 Fasteners: rust proof, tamper proof, exposed.
- 3 Washers: of same material as sheet metal, 1 mm thick with rubber packings.

PART 3 - EXECUTION

3.1 INSTALLATION

- 1 flash roof penetrations with material matching roof panels, and make watertight.

3.2 GUTTERS

- 1 Install gutter along back of roof, with steel pile downspout.

METAL DOORS AND FRAMES - 08 11 00

PART 1 - GENERAL

1.1 REFERENCES

- 1 American Society for Testing and Materials International (ASTM)
 - 1 ASTM A 653/A 653M-[06a], Specification for Steel Sheet, Zinc-Coated (Galvanized) or Zinc-Iron Alloy-Coated (Galvannealed) by the Hot-Dip Process.
- 2 Canadian General Standards Board (CGSB)
 - 1 CAN/CGSB-1.181-[99], Ready-Mixed Organic Zinc-Rich Coating
- 3 Canadian Standards Association (CSA International)
 - 1 CSA-G40.20-[04]G40.21-[04], General Requirements for Rolled or Welded Structural Quality Steel/Structural Quality Steel.
 - 2 CSA W59-[03], Welded Steel Construction (Metal Arc Welding).
- 4 Canadian Steel Door Manufacturers' Association (CSDMA)
 - 1 CSDMA, Recommended Specifications for Commercial Steel Doors and Frames, [2000].

1.2 ACTION AND INFORMATIONAL SUBMITTALS

- 1 Provide shop drawings: in accordance with Section [01 33 00 - Submittal Procedures].
- 2 Indicate each type of door, material, steel core thicknesses, mortises, reinforcements, location of exposed fasteners, openings, arrangement of hardware and finishes.
- 3 Indicate each type frame material, core thickness, reinforcements, glazing stops, location of anchors and exposed fastenings finishes.
- 4 Include schedule identifying each unit, with door marks and numbers relating to numbering on drawings and door schedule.

PART 2 - PRODUCTS

2.1 DOOR CORE MATERIALS

- 1 Expanded polystyrene: CAN/ULC-S701, Type 4, density 16 to 32 kg/m³.

2.2 PAINT

- 1 Field paint steel doors and frames in accordance with Section[s] [09 01 23 - Interior Painting]. Protect weatherstrips from paint. Provide final finish free of scratches or other blemishes.
- 2 Exterior top and bottom caps: rigid polyvinylchloride extrusion

2.3 ACCESSORIES

- 1 Door silencers: single stud rubber/hegrene type.
- 2 Exterior top and bottom caps: rigid polyvinylchloride extrusion

conforming to CGSB 41-GP-19Ma.

- 3 Door bottom seal.
- 4 Door closer with hold-open. ANSI 156.4 Grade 1
 - 1 Hold open angle set to 150°

2.4 FRAMES FABRICATION GENERAL

- 1 Fabricate frames in accordance with CSDMA specifications.
- 2 Fabricate frames to profiles and maximum face sizes as indicated.
- 3 Exterior frames: 1.2 mm thermally broken type construction.
- 4 Blank, reinforce, drill and tap frames for mortised, templated hardware, using templates provided by finish hardware supplier. Reinforce frames for surface mounted hardware.
- 5 Provide factory-applied touch up primer at areas where zinc coating has been removed during fabrication.
- 6 Insulate exterior frame components with polyurethane insulation.

2.5 FRAME ANCHORAGE

- 1 Provide appropriate anchorage to floor and wall construction.
- 2 Locate each wall anchor immediately above or below each hinge reinforcement on hinge jamb and directly opposite on strike jamb.

2.6 FRAMES: WELDED TYPE

- 1 Welding in accordance with CSA W59.
- 2 Accurately mitre or mechanically joint frame product and securely weld on inside of profile.
- 3 Cope accurately and securely weld butt joints of mullions, transom bars, centre rails and sills.
- 4 Grind welded joints and corners to a flat plane, fill with metallic paste and sand to uniform smooth finish.
- 5 Securely attach floor anchors to inside of each jamb profile.

2.7 DOOR FABRICATION GENERAL

- 1 Doors: swing type, flush, with provision for glass and/or louvre openings as indicated.
- 2 Blank, reinforce, drill doors and tap for mortised, templated hardware.
- 3 Factory prepare holes 12.7 mm diameter and larger except mounting and through-bolt holes, on site, at time of hardware installation.
- 4 Reinforce doors where required, for surface mounted hardware.
- 5 Provide factory-applied touch-up primer at areas where zinc coating has been removed during fabrication.

2.8 THERMALLY BROKEN DOORS AND FRAMES

- 1 Fabricate thermally broken doors by using insulated core and separating exterior parts from interior parts with continuous interlocking thermal break.
- 2 Thermal break: rigid polyvinylchloride extrusion conforming to CGSB 41-GP-19Ma.
- 3 Fabricate thermally broken frames separating exterior parts from interior parts with continuous interlocking thermal break.
- 4 Apply insulation.

PART 3 - EXECUTION

3.1 MANUFACTURER'S INSTRUCTIONS

- 1 Compliance: comply with manufacturer's written recommendations or specifications, including product technical bulletins, handling, storage and installation instructions, and datasheets.

3.2 INSTALLATION GENERAL

- 1 Install doors and frames to CSDMA Installation Guide.

3.3 FRAME INSTALLATION

- 1 Set frames plumb, square, level and at correct elevation.
- 2 Secure anchorages and connections to adjacent construction.
- 3 Brace frames rigidly in position while building-in. Install temporary horizontal wood spreader at third points of door opening to maintain frame width. Provide vertical support at centre of head for openings over 1200 mm wide. Remove temporary spreaders after frames are built-in.
- 4 Make allowances for deflection of structure to ensure structural loads are not transmitted to frames.
- 5 Caulk perimeter of frames between frame and adjacent material.
- 6 Maintain continuity of air barrier and vapour barrier.

3.4 DOOR INSTALLATION

- 1 Install doors and hardware in accordance with hardware templates and manufacturer's instructions and Section [08 71 00 - Door Hardware].
- 2 Provide even margins between doors and jambs and doors and finished floor.
- 3 Adjust operable parts for correct function.

3.5 FINISH REPAIRS

- 1 Touch up with primer finishes damaged during installation
- 2 Fill exposed frame anchors [and] [surfaces with imperfections] with metallic paste filler and sand to a uniform smooth finish.

		FE - PUMPING STATION 5365 HWY 96, WOLFE ISLAND, ON	Date/Date Jun 23/14	Environment Canada Environnement Canada Property Management District 2 Gestion de l'immobilier District 2
Jun 23/14	FOR TENDER	DWG.NO.-DESSIN NO.	Scale/Echelle n.l.s.	
Date	REVISION	301		CANADA CENTRE FOR INLAND WATERS LE CENTRE CANADIEN DES EAUX INTÉRIEURES
				867 LAKESHORE RD BURLINGTON, ON L7R 4A6

ROOM FINISH SCHEDULE

No.	Room Name	Floor Mat/Fin.	Base	Walls Material/Finish	Ceiling Material/Finish	Height	Remarks
1	LAB	VF	VF	PLY PT	PLY PT	2440+	VINYL FLOORING TO BE CONTINUOUS +100mm VERTICAL AT WALLS VINYL FLOORING TO EXTEND 900mm UP WALLS AT CENTRUGE AND FRIDGE

ROOM FINISH ABBREVIATIONS:

CONC - CONCRETE
 PLY - PLYWOOD
 NIC - NOT IN CONTRACT
 PT - PAINT
 VF - VINYL FLOORING

PLYWOOD INSTALLED IN FULL SHEETS VERTICALLY FROM FLOOR TO 2440 AFF. 2440AFF TO CEILING IN 1220 WIDTHS. INSTALL FASTENERS FLUSH, PUTTY OVER AND SMOOTH TO RECEIVE FINISH.

DOOR SCHEDULE

N.T.S.

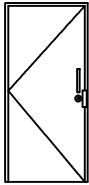

DOOR TYPE A
 HOLLOW METAL DOOR
 900 X 2150 X 45 THICK
 PAINT FINISH
 INSULATED
 (LEFT HAND)

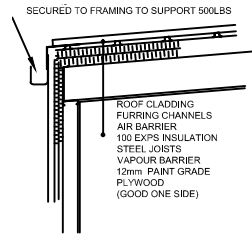

1 ROOF DETAIL
 302 SCALE: 1:20

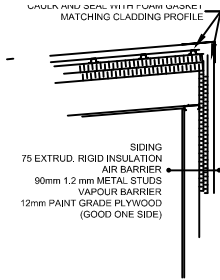

2 WALL DETAILS
 302 SCALE: 1:20

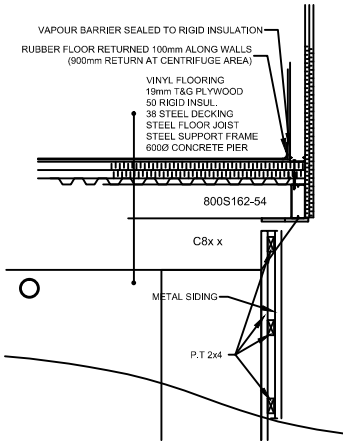

4 FLOOR DETAILS
 302 SCALE: 1:20

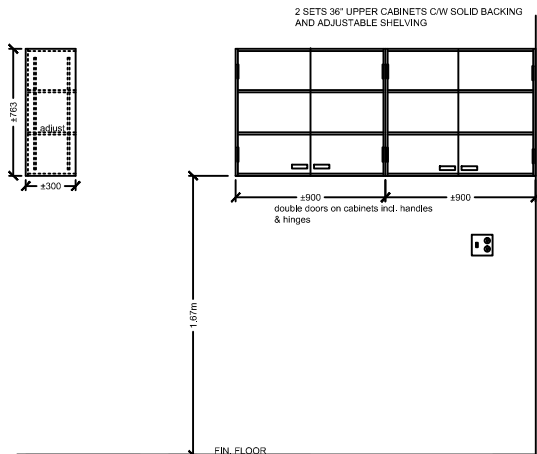

6 DESK / WORKSTATION
 302 SCALE: 1:20

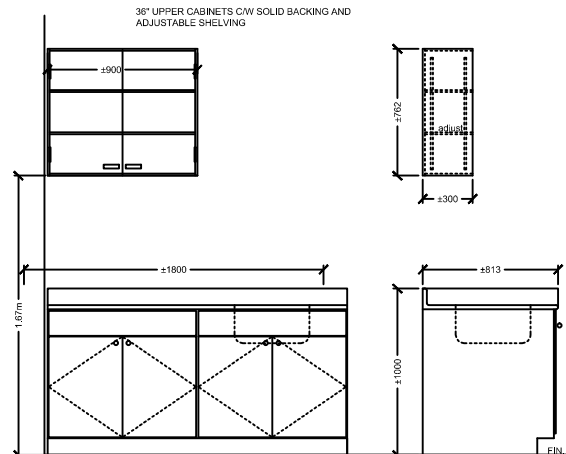

5 SAMPLING COUNTER
 302 SCALE: 1:20

SPECIFICATIONS

ARCHITECTURAL WOODWORK - 06 40 00

PART 1 - GENERAL

1.1 REFERENCES

- Architectural Woodwork Manufacturers Association of Canada (AWMAC) and Architectural Woodwork Institute (AWI)
 - Architectural Woodwork Quality Standards Illustrated, 8th edition, Version 1.0 (2009).
- CSA International
 - CSA B111-[74(R2003)], Wire Nails, Spikes and Staples.
 - CSA O141-[05], Softwood Lumber.
 - CSA O151-[09], Canadian Softwood Plywood.
- Forest Stewardship Council (FSC)
 - FSC-STD-01-001-[2004], FSC Principle and Criteria for Forest Stewardship.
- National Lumber Grades Authority (NLGA)
 - Standard Grading Rules for Canadian Lumber [2003(R2007)].

PART 2 - PRODUCTS

2.1 MATERIALS

- Certified Wood, wood products and materials used, produced from wood obtained from forests certified by FSC Accredited Certification Body in accordance with FSC-STD-01-001.
 - Softwood lumber: unless specified otherwise, S4S, moisture content [15] [19] % or less in accordance with following standards:
 - CSA O141.
 - NLGA Standard Grading Rules for Canadian Lumber.
 - Hardwood lumber: moisture content [] % or less in accordance with following standards:
 - National Hardwood Lumber Association (NHLA).
 - AWMAC [custom] [premium] grade, moisture content as specified.
 - Canadian softwood plywood (CSP): to CSA O151, standard construction, [FSC certified].
 - Plywood resin to contain no added urea-formaldehyde.
 - Hardboard:
 - To CAN/CGSB-11.3, [FSC certified].
 - Hardboard resin to contain no added urea-formaldehyde.
 - Nails and staples: to CSA B111.
 - Wood screws: plain, type and size to suit application.
 - Clear Wood Finishes: VOC limit [350] [550] g/L maximum to [GS-11][SCAQMD Rule 1113]
- #### 2.2 MANUFACTURED UNITS
- Casework:
 - Fabricate caseworks to AWMAC premium quality grade.
 - Furring, blocking, nailing strips, grounds and rough bucks and sleepers.
 - Board sizes: "standard" or better grade.
 - Dimension sizes: "standard" light framing or better grade.
 - Urea-formaldehyde free.
 - Backs, Softwood and poplar plywood, 8 mm thick.
 - Shelving, Softwood and poplar plywood, 12 mm thick.
 - Drawers, Fabricate drawers to AWMAC premium grade supplemented as follows:
 - Sides and Backs, Softwood and poplar plywood 12 mm thick.
 - Bottoms, Softwood and poplar 6mm thick.
 - Fronts, Softwood and poplar plywood, 12 mm thick.
 - Casework Doors:
 - Fabricate doors to AWMAC premium grade supplemented as follows:
 - Solid wood: 12 mm thick.

2.3 FABRICATION

- Set nails and countersink screws apply wood filler to indentations, sand smooth and leave ready to receive finish.
- Shop install cabinet hardware for doors, shelves and drawers.

- Shelving to cabinetwork to be adjustable unless otherwise noted
- Obtain governing dimensions before fabricating items which are to accommodate or abut appliances, equipment and other materials.
- Ensure adjacent parts of continuous laminate work match in colour and pattern.
- Veneer laminated plastic to core material in accordance with adhesive manufacturer's instructions. Ensure core and laminate profiles coincide to provide continuous support and bond over entire surface. Use continuous lengths up to 1800 mm.
- Use straight self-edging laminate strip for flatwork to cover exposed edge of core material. Chamfer exposed edges uniformly at approximately 20 degrees. Do not mitre laminate edges.

PART 3 - EXECUTION

3.2 INSTALLATION

- Do architectural woodwork to Quality Standards of AWMAC.
- Install prefinished millwork at locations shown on drawings. Position accurately, level, plumb straight.
- Fasten and anchor millwork securely. Supply and install heavy duty fixture attachments for wall mounted cabinets.
- Scribe and cut as required to fit abutting walls and to fit properly into recesses and to accommodate piping, columns, fixtures, outlets or other projecting, intersecting or penetrating objects.
- At junction of plastic laminate counter back splash and adjacent wall finish, apply small bead of sealant.
- Fit hardware accurately and securely in accordance with manufacturer's written instructions.

FLOORING - 09 65 16

PART 1 - GENERAL

1.1 ACTION AND INFORMATIONAL SUBMITTALS

- Provide product data in accordance with Section [01 33 00 - Submittal Procedures].
- Submit samples in accordance with Section [01 33 00 - Submittal Procedures].
- Submit duplicate 300 x 300 mm sample pieces of sheet material.
 - Provide maintenance data for resilient flooring for incorporation into manual specified in Section [01 78 00 - Closeout Submittals].

PART 2 - PRODUCTS

2.1 MATERIALS

- Smooth face, Slip Resistant sheet vinyl - Forbo Linoleum Inc.:
 - Surface: Non Studded, Flat, low-sheen.
 - Width: 2m
 - Gauge: 2mm
 - Colours and patterns selected from manufacturers standards.
 - Primers and adhesives: of types recommended by flooring manufacturer for specific material on applicable substrate, above grade.
 - Heat Welded Joints colour matched and as per manufactures recommendations.
- Metal edge strips at all edges along wall.

PART 3 - EXECUTION

3.1 MANUFACTURER'S INSTRUCTIONS

- Compliance: comply with manufacturer's written recommendations or specifications, including product technical bulletins, handling, storage and installation instructions, and datasheets.

3.2 PREPARATION

- Prime plywood sub-floor to resilient flooring manufacturer's printed instructions.

3.3 APPLICATION: FLOORING

- Provide high ventilation rate, with maximum outside air, during installation, and for 48 hours after installation. If possible, vent directly to outside.
- Apply adhesive uniformly using recommended trowel. Do not spread more adhesive than can be covered by flooring before initial set takes place.
- Seal seams of rubber sheet flooring in accordance with manufacturer's printed instructions.
- As installation progresses, and after installation roll flooring with 45 kg minimum roller to ensure full adhesion.
- Install metal edge strips at unprotected or exposed edges

where flooring terminates.

3.4 APPLICATION-BASE

- Continue Rubber Flooring without joint 100mm along walls.

PAINTING - 09 65 16

PART 1 - GENERAL

1.1 REFERENCES

- Master Painters Institute (MPI)
 - MPI Architectural Painting Specifications Manual, [2004].

1.2 ACTION AND INFORMATIONAL SUBMITTALS

- Submittals in accordance with Section [01 33 00 - Submittal Procedures].
- Product Data, Submit product data and instructions for each paint and coating product to be used.
- Samples, Submit full range colour sample chips to indicate where colour availability is restricted.
- Closeout Submittals: submit maintenance data for incorporation into manual specified in Section 01 78 00 - Closeout Submittals include following:
 - Product name, type and use.
 - Manufacturer's product number.
 - Colour number(s).
 - MPI Environmentally Friendly classification system rating.

PART 2 - PRODUCTS

2.1 MATERIALS

- Paint materials listed in the MPI Approved Products List (APL) are acceptable for use on this project.
- Provide paint materials for paint systems from single manufacturer.
- Only qualified products with E2 or E3 "Environmentally Friendly" rating are acceptable for use on this project.
- Conform to latest MPI requirements for interior painting work including preparation and priming.
- Materials (primers, paints, coatings, varnishes, stains, lacquers, fillers, thinners, solvents, etc.) in accordance with MPI Architectural Painting Specification Manual "Approved Product" listing.
- Provide paint products meeting MPI "Environmentally Friendly" E2, E3 ratings based on VOC (EPA Method 24) content levels.
- Ensure manufacture and process of both water-borne surface coatings and recycled water-borne surface coatings does not release:
 - Matter in undiluted production plant effluent generating "Biochemical Oxygen Demand" (BOD) in excess of [15] mg/L to natural watercourse or sewage treatment facility lacking secondary treatment.
 - Total Suspended Solids (TSS) in undiluted production plant effluent in excess of [15] mg/L to natural watercourse or a sewage treatment facility lacking secondary treatment.

2.2 COLOURS

- Owner will provide Colour Schedule after Contract.
- Colour schedule will be based upon selection of one base colour.
- Selection of colours from manufacturers full range of colours.
- Second coat in three coat system to be tinted slightly lighter colour than top coat to show visible difference between coats.

2.3 INTERIOR

- Structural steel and metal fabrications: columns, beams, joists:
 - INT 5.1A - enamel gloss finish.
- Wood paneling and casework: partitions, panels, shelving, millwork:
 - INT 6.4J - Polyurethane varnish semi-gloss finish.
- gypsum board: gypsum wallboard, drywall:
 - INT 9.2A - Latex eggshell finish (over latex sealer).

PART 3 - EXECUTION

3.1 MANUFACTURER'S INSTRUCTIONS

- Compliance: comply with manufacturer's written recommendations or specifications, including product technical bulletins, handling, storage and installation instructions, and data sheet.

3.2 GENERAL

- Perform preparation and operations for interior painting in accordance with MPI Architectural Painting Specifications Manual except where specified otherwise.
- Apply paint materials in accordance with paint manufacturer's written application instructions.

3.3 PREPARATION

1. Protection:

- Protect existing building surfaces and adjacent structures from paint splatters, markings and other damage by suitable non-staining covers or masking.
- Protect factory finished products and equipment.

2. Surface Preparation:

- Remove electrical cover plates, light fixtures, surface hardware on doors, bath accessories and other surface mounted equipment, fittings and fasteners prior to undertaking painting operations. Identify and store items in secure location and re-installed after painting is completed.
- Move and cover furniture and portable equipment as necessary to carry out painting operations. Replace as painting operations progress.
- Clean and prepare surfaces in accordance with MPI Architectural Painting Specification Manual requirements. Refer to MPI Manual in regard to specific requirements and as follows:
 - Remove dust, dirt, and other surface debris by wiping with dry, clean cloths.
 - Rinse scrubbed surfaces with clean water until foreign matter is flushed from surface.
 - Allow surfaces to drain completely and allow to dry thoroughly.
 - Prepare surfaces for water-based painting, water-based cleaners should be used in place of organic solvents.
- Many water-based paints cannot be removed with water once dried. Minimize use of mineral spirits or organic solvents to clean up water-based paints.
- Prevent contamination of cleaned surfaces by salts, acids, alkalis, other corrosive chemicals, grease, oil and solvents before prime coat is applied and between applications of remaining coats. Apply primer, paint, or pretreatment as soon as possible after cleaning and before deterioration occurs.
- Where possible, prime non-exposed surfaces of new wood surfaces before installation. Use same primers as specified for exposed surfaces.
 - Apply vinyl sealer to MPI #36 over knots, pitch, sap and resinous areas.
 - Apply wood filler to nail holes and cracks.
 - Tint filler to match stains for stained woodwork.
 - Sand and dust between coats as required to provide adequate adhesion for next coat and to remove defects visible from a distance up to 1000 mm.
 - Clean metal surfaces to be painted by removing rust, loose mill scale, welding slag, dirt, oil, grease and other foreign substances in accordance with MPI requirements. Remove traces of blast products from surfaces, pockets and corners to be painted by brushing with clean brushes.
 - Touch up of shop primers with primer as specified.

3.4 APPLICATION

- Brush and Roller Application:
 - Apply paint in uniform layer using brush and/or roller type suitable for application.
 - Work paint into cracks, crevices and corners.
 - Paint surfaces and corners not accessible to brush using spray, daubers and/or sheepskins. Paint surfaces and corners not accessible to roller using brush, daubers or sheepskins.
 - Brush and/or roll out runs and sags, and over-lap marks. Rolled surfaces free of roller tracking and heavy stipple.
 - Remove runs, sags and brush marks from finished work and repaint.
 - Apply coats of paint continuous film of uniform thickness. Repair thin spots or bare areas before next coat of paint is applied.
- Allow surfaces to dry and properly cure after cleaning and between subsequent coats for minimum time period as recommended by manufacturer.
- Sand and dust between coats to remove visible defects.
- Finish surfaces both above and below sight lines as specified for surrounding surfaces, including such surfaces as tops of interior cupboards and cabinets and projecting ledges.

3.5 FIELD QUALITY CONTROL

- Standard of Acceptance:
 - Walls: no defects visible from a distance of 1000 mm at 90 degrees to surface.
 - Ceilings: no defects visible from floor at 45 degrees to surface when viewed using final lighting source.
 - Final coat to exhibit uniformity of colour and uniformity of sheen across full surface area.
- Field inspection of painting operations to be carried out by Owner.

PROJECT										PANEL MAINS														
FORT ERIE SAMPLING STATION										100A					120/240V					1P				
LOAD DESCRIPTION	NO. OF REC.	NO. OF FIC.	NO. OF FIC.	LOAD/PHASE			BRK. SIZE	CCT. NO.	PHASE			CCT. NO.	BRK. SIZE	LOAD/PHASE			WTS. PER FIC.	NO. OF FIC.	NO. OF REC.	LOAD DESCRIPTION				
				A	B	C			A	B	C			A	B	C								
CEILING LIGHTS							15	1			2	15												
EMERGENCY LIGHTS							15	3			4	15												
FRIDGE							20	5			6	15												
ELECTRIC HEATERS							30A	7			8													
HEAT TRACE							2P	9			10	2P												
WALL MOUNT DAMPER								11			12													
WALL MOUNT DAMPER								13			14	2P												
WALL MOUNT DAMPER								2P			15													
WALL MOUNT DAMPER								20			17													
WALL MOUNT DAMPER								19			20													
WALL MOUNT DAMPER								21			22													
WALL MOUNT DAMPER								23			24													
WALL MOUNT DAMPER								25			26													
WALL MOUNT DAMPER								27			28													
TOTAL LOADS				A	B	C				A	B	C				A	B	C						
LIGHTS				W	●	×				TOTAL LOADS			CONNECTED			DEMAND			PANEL NO.					
RECEPTACLES				W	●	×													"P1"					
MOTORS & HEATERS				W	●	×																		

3 PANEL SCHEDULE
SCALE: 1:20

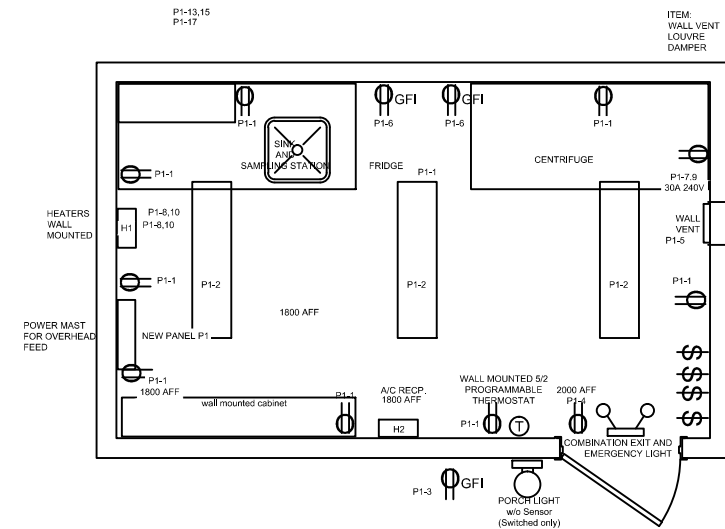

1 ELECTRICAL LAYOUT
SCALE: 1:20

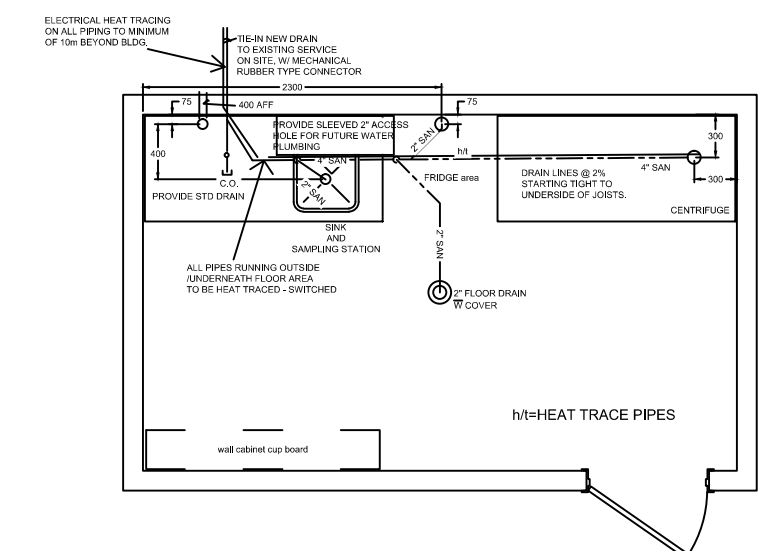

2 PLUMBING LAYOUT
SCALE: 1:20

SPECIFICATIONS

DRAINAGE WASTE AND VENT PIPING - 22 13 18

PART 1 - GENERAL

1.1 REFERENCES

- ASTM International Inc.
 - ASTM D 2564-[04e1], Standard Specification for Solvent Cements for Poly(Vinyl-Chloride) (PVC) Plastic Piping Systems.
- Canadian Standards Association (CSA International)
 - CAN/CSA-Series B1800-[06], Thermoplastic Nonpressure Pipe Compendium - B1800 Series.

1.2 ACTION AND INFORMATIONAL SUBMITTALS

- Provide submittals in accordance with Section [01 33 00 - Submittal Procedures].

2 Product Data:

- Provide manufacturer's printed product literature and datasheets for piping and adhesives, and include product characteristics, performance criteria, physical size, finish and limitations.

PART 2 - PRODUCTS

2.1 PIPING AND FITTINGS

- For above ground DWV piping to:
 - CAN/CSA B1800.

2.2 JOINTS

- Solvent weld for ABS: to ASTM D 2235.

PART 3 - EXECUTION

3.1 INSTALLATION

- Install in accordance with National Plumbing Code.

3.2 PERFORMANCE VERIFICATION

- Cleanouts:
 - Ensure accessible and that access doors are correctly located.
 - Open, cover with linseed oil and re-seal.
 - Verify cleanout rods can probe as far as the next cleanout, at least.
- Test to ensure traps are fully and permanently primed.
- Ensure fixtures are properly anchored, connected to system and effectively vented.

PACKAGED WALL EXHAUSTERS - 23 34 25

PART 1 - GENERAL

1.1 REFERENCES

- Air Movement and Control Association (AMCA)
 - AMCA Publication 99-[2003], Standards Handbook (Revised 2003).
 - AMCA 300-[1996], Reverberant Room Method for Sound Testing of Fans.
 - AMCA 301-[1990], Methods for Calculating Fan Sound Ratings from Laboratory Test Data.
- American National Standards Institute (ANSI)
 - ANSI/AMCA 210-[99], Laboratory Methods of Testing Fans for Aerodynamic Performance Rating.

1.3 ACTION AND INFORMATIONAL SUBMITTALS

- Product Data:
 - Submit manufacturer's printed product literature, specifications and data sheets. Include product characteristics, performance criteria, and limitations.
- Shop Drawings:
 - Submit shop drawings.
 - Include:
 - Fan performance curves showing specified point of operation.
 - Sound rating data.
- Closeout Submittals
 - Provide operation and maintenance data for incorporation into manual specified in Section 01 78 00 - Closeout Submittals.

PART 2 - PRODUCTS

2.1 WALL EXHAUST:

- Wall exhaust unit: Twin City Fan & Blower - TCPE102AE or approved alternate.
- Dampener: Arrow - ID200 or approved alternate.
- Louvre: Arrow - EA-475-DH or approved alternate.

PART 3 - EXECUTION

3.1 MANUFACTURER'S INSTRUCTIONS

- Compliance: comply with manufacturer's written recommendations or specifications, including product technical bulletins, handling, storage and installation instructions, and datasheet.

3.2 Installation

- Install in accordance with manufacturer's instructions.

COMMON WORK RESULTS FOR ELECTRICAL - 26 05 00

PART 1 - GENERAL

1.1 REFERENCES

- Canadian Standards Association (CSA International)
 - CSA C22.1-[06], Canadian Electrical Code, Part 1 (20th Edition), Safety Standard for Electrical Installations.

1.2 DESIGN REQUIREMENTS

- Operating voltages: to CAN3-C235.
- Motors, electric heating, control and distribution devices and equipment to operate satisfactorily at 60 Hz within normal operating limits established by above standard.
- Language operation requirements: provide identification nameplates and labels for control items in English.

1.3 ACTION AND INFORMATIONAL SUBMITTALS

- Submittals: in accordance with Section 01 33 00 - Submittal Procedures.
 - Shop drawings:
 - Submit drawings.
 - Submit wiring diagrams and installation details of equipment indicating proposed location, layout and arrangement, control panels, accessories, piping, ductwork, and other items that must be shown to ensure co-ordinated installation.
 - Indicate drawings clearances for operation, maintenance, and replacement of operating equipment devices.
 - Submit 4 number of copies drawings and product data to authority having jurisdiction.
 - If changes are required, notify Departmental Representative of these changes before they are made.
- Quality Control: in accordance with Section [01 45 00 - Quality Control].
 - Provide CSA certified [equipment] [and] [material].
 - Permits and fees: in accordance with General Conditions of contract.
 - Submit certificate of acceptance from authority having jurisdiction upon completion of Work to Departmental Representative.

1.4 QUALITY ASSURANCE

- Qualifications: electrical Work to be carried out by qualified, licensed electricians who hold valid Master Electrical Contractor license or apprentices in accordance with authorities having jurisdiction as per the conditions of Provincial Act respecting manpower vocational training and qualification.
 - Employees registered in provincial apprentices program: permitted, under direct supervision of qualified licensed electrician, to perform specific tasks.
 - Permitted activities: determined based on training level attained and demonstration of ability to perform specific duties.

PART 2 - PRODUCTS

2.1 MATERIALS AND EQUIPMENT

- Material and equipment to be CSA certified.
- Factory assemble control panels and component assemblies.

2.2 ELECTRIC MOTORS, EQUIPMENT AND CONTROLS

- Verify installation and co-ordination responsibilities related to motors, equipment and controls, as indicated.

2.3 WIRING TERMINATIONS

- Ensure lugs, terminals, screws used for termination of wiring are suitable for either copper or aluminum conductors.

2.4 WIRING IDENTIFICATION

- Identify wiring with permanent indelible identifying markings, numbered, on both ends of phase conductors of feeders and branch circuit wiring.
- Maintain phase sequence and colour coding throughout.
- Colour coding: to CSA C22.1.

PART 3 - EXECUTION

3.1 INSTALLATION

- Do complete installation in accordance with CSA C22.1.
- Do overhead and underground systems in accordance with CSA C22.3 No.1.

3.2 NAMEPLATES AND LABELS

- Ensure manufacturer's nameplates, CSA labels and identification nameplates are visible and legible after equipment is installed.

3.3 LOCATION OF OUTLETS

- Locate outlets as shown on drawings
- Locate light switches on latch side of doors.

3.4 MOUNTING HEIGHTS

- Mounting height of equipment is from finished floor to centreline of equipment unless specified or indicated otherwise.

2

- If mounting height of equipment is not specified or indicated, verify before proceeding with installation.
- Install electrical equipment at following heights unless indicated otherwise.
 - Local switches: 1400 mm.
 - Wall receptacles:
 - General: 1400 mm.
 - Panelboards: as required by Code.

3.5 CO-ORDINATION OF PROTECTIVE DEVICES

- Ensure circuit protective devices such as overcurrent trips, relays and fuses are installed to required values and settings.

3.6 FIELD QUALITY CONTROL

- Load Balance:
 - Measure phase current to panelboards with normal loads (lighting) operating at time of acceptance; adjust branch circuit connections as required to obtain best balance of current between phases and record changes.
 - Measure phase voltages at loads and adjust transformer taps to within 2% of rated voltage of equipment.
 - Provide upon completion of work, load balance report as directed in PART 1 - SUBMITTALS: phase and neutral currents on panelboards, dry-core transformers and motor control centres, operating under normal load, as well as hour and date on which each load was measured, and voltage at time of test.
- Conduct following tests:
 - Power and distribution system including phasing, voltage, grounding and load balancing.
 - Circuits originating from branch distribution panels.
 - Lighting and its control.
 - Motors, heaters and associated control equipment including sequenced operation of systems where applicable.
- Carry out tests in presence of Departmental Representative.
- Provide instruments, meters, equipment and personnel required to conduct tests during and at conclusion of project.

PANELBOARDS BREAKER TYPE - 26 24 16

PART 1 - GENERAL

1.1 REFERENCES

- Canadian Standards Association (CSA International)
 - CSA C22.2 No.29-[M1989(R2000)], Panelboards and enclosed Panelboards.

1.2 SHOP DRAWINGS

- Submit shop drawings in accordance with Section 01 33 00 - Submittal Procedures.
 - Drawings to include electrical detail of panel, branch breaker type, quantity, ampacity and enclosure dimension.

PART 2 - PRODUCTS

2.1 PANELBOARDS

- Panelboards: to [CSA C22.2 No.29] and product of one manufacturer.
 - Install circuit breakers in panelboards before shipment.
 - In addition to CSA requirements manufacturer's nameplate must show fault current that panel including breakers has been built to withstand.
 - Sequence phase bussing with odd numbered breakers on left and even on right, with each breaker identified by permanent number identification as to circuit number and phase.
 - Panelboards: mains, number of circuits, and number and size of branch circuit breakers as indicated.
 - Two keys for each panelboard and key panelboards alike.
 - [Copper] [Aluminum] bus with neutral of same ampere rating as mains.
 - Mains: suitable for [bolt-on] breakers.
 - Trim with concealed front bolts and hinges.
 - Trim and door finish: baked grey enamel.

2.2 BREAKERS

- Breakers [with thermal and magnetic tripping] in panelboards except as indicated otherwise.
 - Main breaker: separately mounted on top or bottom of panel to suit cable entry. When mounted vertically, down position should open breaker.

2.3 EQUIPMENT IDENTIFICATION

- Provide equipment identification in accordance with Section [26 05 00 - Common Work Results - Electrical].
 - Complete circuit directory with typewritten legend showing location and load of each circuit.

PART 3 - EXECUTION

3.1 INSTALLATION

- Locate panelboards as indicated and mount securely, plumb, true and square, to adjoining surfaces.
- Mount panelboards to 1400AFF.
- Connect loads to circuits.
- Connect neutral conductors to common neutral bus with respective neutral identified.

Date	Jun 23/14	FE - PUMPING STATION 5365 HWY 96, WOLFE ISLAND, ON	Date/Date Jun 23/14	Environment Canada Property Management District 2	Environnement Canada Gestion de l'immobilier District 2
DWG. NO. - DESSIN NO.	501		Scale/Echelle n.t.s.	CANADA CENTRE FOR INLAND WATERS LE CENTRE CANADIEN DES EAUX INTERIEURES	
Date	REVISION			867 LAKESHORE RD BURLINGTON, ON L7R 4A6	