

Dwg. 1

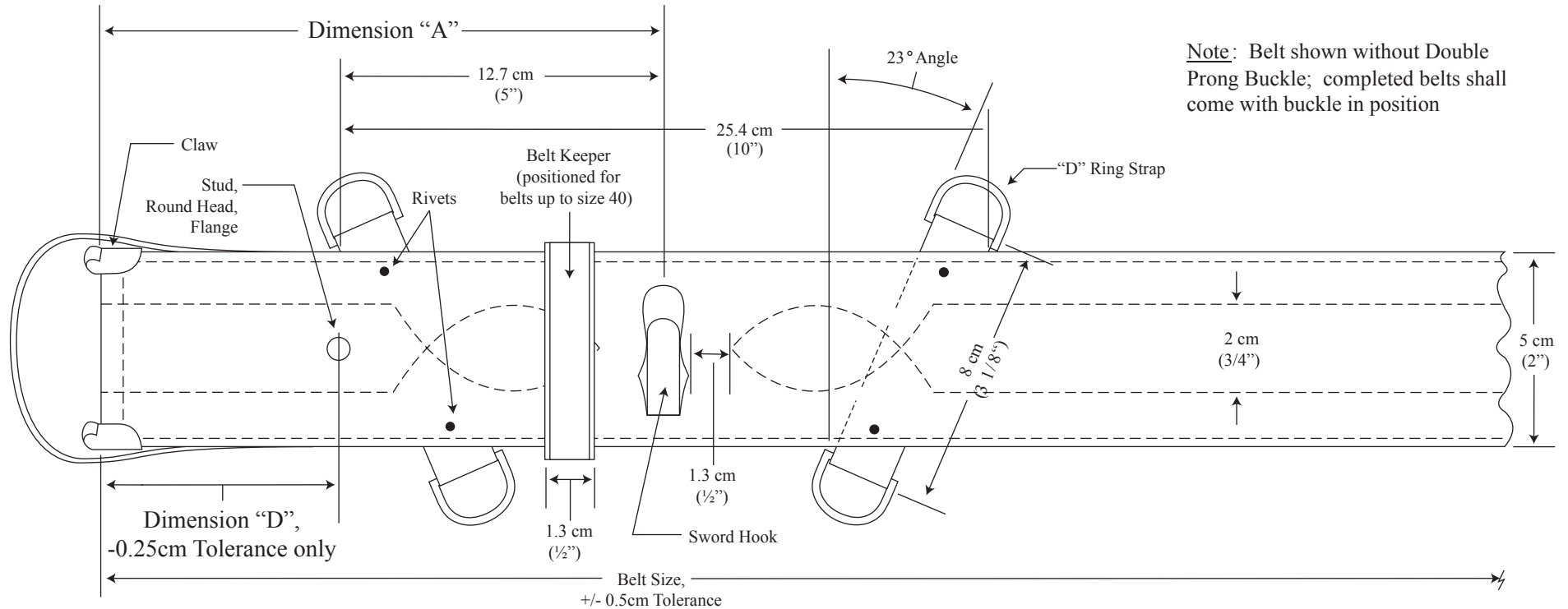

Note: Belt shown without Double Prong Buckle; completed belts shall come with buckle in position

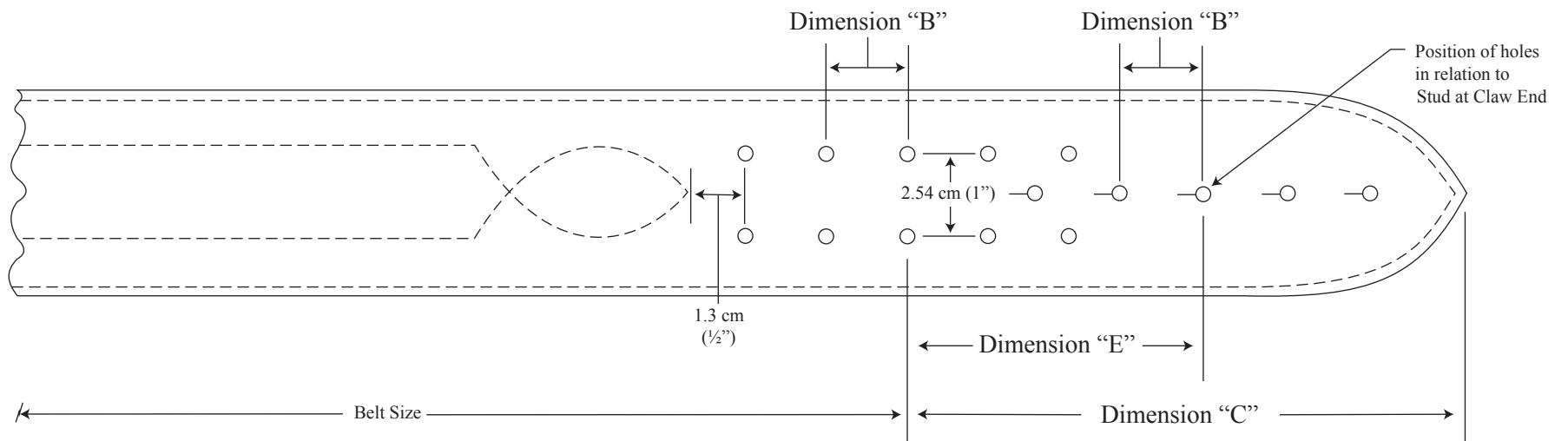

Dwg. 1

NOT TO SCALE

Tolerance: +/- 0.25 cm unless otherwise indicated

Dwg. 2

SHOULDER STRAP ASSEMBLY

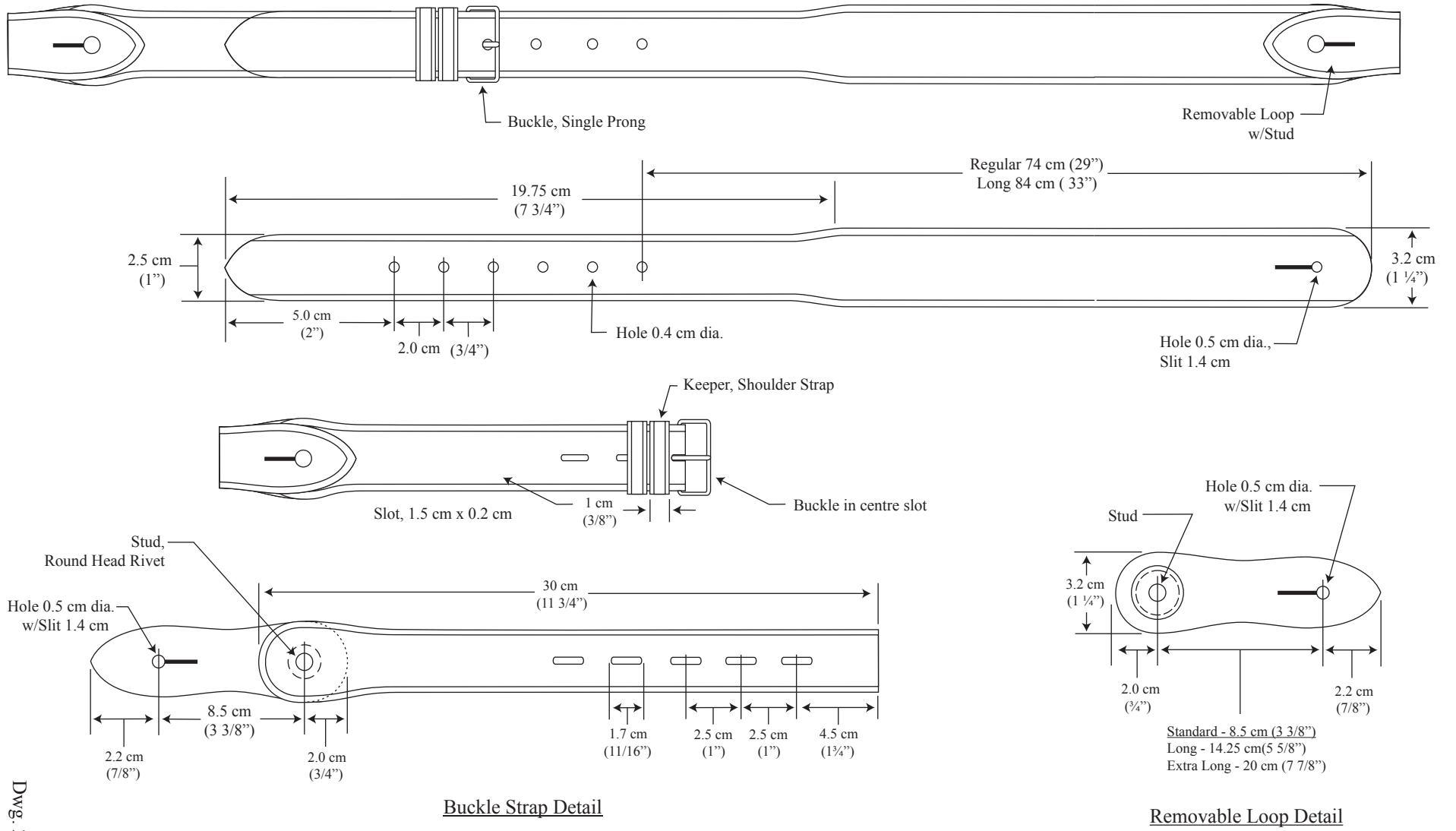

Dwg. 2

NOT TO SCALE

Tolerance: +/- 0.25 cm unless otherwise indicated