



Royal Canadian Mounted Police
Gendarmerie royale du Canada

Doc. no: G.S. 1045-334
Date: 2015-04-23

Specification

Shirt, Special Duty, Blue, Short Sleeve

This document has 19 pages including the drawings.

This document was created in English.

The document is available in English and French.

English/Anglais
Français/French

The photograph on this page is for reference only.



Modifications

Date	Para. No's	Modifications
2007-11-14		New Specification
2009-07-24	Page 4, Para. 4.1.4 Scale of Measurements	Buttonhole & Bar Tack Thread amended to be same as sewing thread. Chest and Hem measurements changed to half measurements; measurement for sleeve hem width added.
2012-10-05	Para. 4.3.15 Appendix B	Specify date in numeric form. Tolerances amended for chest, hem circ., side length and depth of yoke.
2013-06-19	Para. 2.6 Para. 4.1.1 Para. 4.1.3 & 4.1.4 Para. 4.1.5 Table I Appendix C	Updated CGSB standard. Added Certificate of compliance or test report. Updated the thread requirement as per industry recommendation and added Certificate of compliance required. Validation Certificate changed to Certificate of Compliance. Test method for Laundering updated to reflect home laundering. Certificate of Compliance definition added.
2015-04-23	Para. 1.1 Para. 1.4 Para. 3.3 Para. 4.1.1 Para. 4.1.5 Para. 4.3.15 Para. 5 Table I Appendix C	Added list of items with MMR numbers to paragraph. Added paragraph relating to translation. Paragraph deleted. Modified paragraph. Updated hook and loop requirements. Modified marking and cleaning instructions. Delivery and Marking paragraphs deleted and subsequent paragraph renumbered. Table I modified for fabric requirements. Removed Appendix C.

RCMP VIEWING SAMPLE

A viewing sample, when available, will be supplied to the successful bidder.

This will be used for the guidance of the manufacturer in all factors not covered by this specification or referred to therein. Variation from the specification may appear in the sample in which case the specification shall govern.

It may be obtained from:

Royal Canadian Mounted Police
ATTN: Uniform and Equipment Program
(440 Coventry Road, Warehouse Building)
1200 Vanier Parkway
Ottawa, Ontario
K1A 0R2

It will be sent “prepaid” and is to be returned “prepaid”.

The viewing sample shall be returned to the RCMP in the same condition as received by the manufacturer. Lost or damaged viewing samples shall be replaced by an identical item or the RCMP shall be reimbursed for the cost of an acceptable replacement.

SPECIFICATION

Shirt, Special Duty, Blue, Short Sleeve

1. Definition

- 1.1 This specification shall govern the manufacture and inspection of Shirt, Special Duty, Blue, Short Sleeve. The specific item covered under this specification with stock number is as follows:
 - i. 6047 - Shirt, Special Duty, Blue, Short Sleeve/ Chemise de fonction spéciale bleue à manches courtes.
- 1.2 This specification, pattern, drawing, viewing sample, or other information issued in connection therewith, may only be used for specific enquiries, solicitations, or orders placed on behalf of the Royal Canadian Mounted Police.
- 1.3 This specification supersedes all previous specifications for Shirt, Special Duty, Blue, Short Sleeve.
- 1.4 This specification has been translated into French from this original English language document.

2. Applicable Specifications

- 2.1 The following publications are applicable to this specification and to the issues in effect on the date of the solicitation, unless otherwise specified.
- 2.2 CAN/CGSB 4.2, Textile Test Methods.
- 2.3 ISO 4915:1991, Textiles - "Stitch Types".
- 2.4 ISO 4916:1991, Textiles - "Seam Types".
- 2.5 CAN/CGSB 4.131-93, Thread, Polyester, Polyester-Covered.
- 2.6 CAN/CGSB 86.1- 2003, Care Labelling of Textiles.

3 General Requirements

- 3.1 The article or material covered by this specification shall be free from imperfections or blemishes such as may affect its appearance or serviceability. In all particulars not covered by this specification or contract documents, production shall be equivalent in all respects to the pattern and viewing sample.
- 3.2 **Design** - The Shirt, Special Duty, Blue, Short Sleeve shall be navy blue in colour constructed from a poly/cotton material. The overall design shall incorporate a front hidden button closure, front bellow pockets with hook and loop secured flaps, and military strap buttons. It shall be constructed in accordance with the patterns, scale of measurements and drawings which form part of this specification.

4. **Detail Requirements**

4.1 **Materials**

- 4.1.1 **Shell** - The shell material shall be 65% Polyester and 35% Cotton with a stain resistant finish meeting the requirements in Table I. It shall be navy in colour to match the colour swatch provided by RCMP Uniform and Equipment program.
- 4.1.2 **Buttons** - The buttons shall be 19 mm diameter, military strap type of nylon composition, black in colour.
- 4.1.3 **Thread** - The thread shall be polyester wrap, polyester core, Tex 40, Class B of matching colour, meeting CAN/CGSB 4.131-93.
- 4.1.4 **Thread for Buttonholes & Bar-Tacks** - The thread shall be polyester wrap, polyester core, Tex 40, Class B meeting CAN/CGSB 4.131-93. It shall be of matching shade to the shell material.
- 4.1.5 **Hook and Loop Tape** - Shall be woven nylon, black in colour, with a high life cycle. The combined hook and loop shall have no less than 8 P.S.I length-wise shear strength with initial peel strength of not less than 1 P.I.W. when tested to ASTM 5169, standard test method for shear strength [dynamic method] of hook and loop touch fasteners and ASTM 5170, standard test method for peel strength ["T" method] of hook and loop touch fasteners."
- 4.2 **Size and Dimensions** - Shirt, Special Duty, Blue, Short Sleeve to this specification shall be supplied in the sizes specified by the R.C.M.P. and to the dimensions given in the scale of measurements and drawings, forming part of this

specification. The garment components shall be shaped, dimensioned and positioned in accordance with the pattern requirements as outlined in Appendix A forming part of this specification.

4.3 **Construction**

4.3.1 **Cutting** - All component parts of the shirt shall be cut from the same piece of material and shall be cut following the grain line on the pattern piece to ensure uniformity of shade.

4.3.2 **Stitching** - Using the specified thread, there shall be no less than 3 and no more than 4 stitches per cm. All stitching shall be lockstitch Type 301 or lockchain stitch Type 401. The beginning and ending of all stitching shall be securely backstitched and tacked unless secured by other stitching. Where seaming, turning and stitching is required the edges shall be properly worked out before stitching. Armhole seams shall be seamed, serged, and top stitched at 6mm. Bar tacks shall be 13 mm in length and made with no less than 18 cover stitches per tack. Care shall be taken to minimize unsightly gathering and puckering.

4.3.3 **Fronts**

4.3.3.1 **Left Front** - The left front shall be constructed in a way to form a hidden button closure. It shall have a front buttonhole flap made from material specified in Para. 4.1.1. Vertical buttonholes shall be positioned on the flap as per pattern. All short sizes shall have 5 buttonholes, all regular sizes shall have 6 buttonholes and all tall sizes shall have 7 buttonholes as outlined in the pattern. All buttonholes shall be sized to properly fit the 19mm button as specified in paragraph 4.1.2. The left front shall be folded back to create a 5cm wide facing and shall be top stitched with a 6mm gauge. The buttonhole flap shall be stitched to the inside facing to create a separation between each hole as per viewing sample. The left front shall conform in all respects to the patterns and drawings.

4.3.3.2 **Right Front** - The right front shall be plain with a folded facing of 5cm wide when finished. The facing shall be folded to the inside and pressed flat. The raw edge shall be turned inward and top stitched using a 2mm gauge as per drawing and viewing sample. Military strap buttons, as specified in Para. 4.1.2, shall be positioned to correspond with the buttonholes. There shall be a piece of loop tape 8.5cm x 2.5cm for a name tag above the right front pocket flap as per pattern template.

- 4.3.4 **Chest Pockets** - There shall be two chest pockets constructed from the material specified in Para. 4.1.1. The pockets shall be a one-piece bellow, patch type, sized and positioned as per patterns. The pockets shall be applied so that the bellow faces the back of the shirt as per drawings and viewing sample. Both pockets shall have a two slot pen pocket, 6cm wide and 15cm deep, made from a single ply of shell material with the hem across the top. The pen pocket shall be stitched at a 2mm gauge to the body of the shirt. Both pockets shall have three pieces of hook tape applied as per drawing #4. Three corners of the pocket shall be bar tacked as shown in drawing #4.
- 4.3.5 **Pocket Flaps** - The flaps shall be constructed of two pieces of shell material as specified in Para. 4.1.1. The side, corner and bottom edges shall be sewn and top stitched with a 6mm gauge. Each flap shall be stitched to the shirt front in a continuous operation and shall be bar tacked at each end. There shall be three pieces of loop tape sewn to the underside of the flap, sized and positioned as per pattern and drawings. The chest pocket flaps shall be constructed and positioned as per the patterns, drawings and viewing sample.
- 4.3.6 **Strap (Military Buttons)** - All straps shall be made from shell material, as per Para 4.1.1, inserted through a military style button as per Para. 4.1.2. and bar tacked in place. The strap shall be 4cm finished length and positioned on the right front as outlined on the pattern and drawings. All straps and buttons shall conform to drawings and viewing sample.
- 4.3.7 **Back** - The completed back panel shall have a double layer yoke. The yoke shall be applied to the top of the back panel and shall be top stitched using a 2mm gauge. The back panel shall have two pleats positioned as per the pattern sewn in at the yoke seam. The back panel shall conform in all respects to the pattern and drawings.
- 4.3.8 **Shoulder Straps** - The straps shall be made of shell material as specified in Para. 4.1.1, sized and dimensioned as per patterns and drawing #3. They shall be seamed, turned and stitched or creased and stitched using a 6mm gauge and placed as per pattern notch. The completed shoulder straps shall be sewn into the armhole seam, parallel with the shoulder seam. The straps shall be secured at the pointed end with hook and loop tape as specified in Para. 4.1.5. The hook tape shall be sewn to the underside of the strap and the loop tape on the shoulder seam. They shall be sized and positioned in accordance with the patterns and drawings. Care shall be taken to ensure that the straps shall lie flat when fastened.

- 4.3.9 **Sleeves** - Both one-piece sleeves shall be made from material as specified in Para. 4.1.1. The bottom edge of the sleeve shall be hemmed by turning in the raw edge, folding this edge under and stitching. The finished sleeve width of the sleeve hem shall be 2cm. The sleeve shall be positioned and constructed as per patterns, drawings and viewing sample.
- 4.3.10 **Joining Sleeves, Underarm and Side Seams** - The join shall be by means of a seamed and serged safety stitch. The armhole shall be top stitched using a 6mm gauge to the body of the shirt as per drawing #3.
- 4.3.11 **Shoulder Patch** - The shoulder patch constructed of loop tape as specified in Para. 4.1.5. The loop tape shall be sized as per pattern and centred on the sleeve head below the shoulder seam as per pattern and attached securely with one row of stitching all around.
- 4.3.12 **Collar** - The collar shall be constructed from two plies of shell material as specified in Para. 4.1.1. The collar shall be seamed, the corners clipped, turned and top stitched using a 6mm gauge. The collar shall be constructed, dimensioned and positioned as per the patterns.
- 4.3.13 **Bottom Hem** - The bottom edge of the shirt front and back shall be hemmed by turning in the raw edge, folding this edge under and stitching.
- 4.3.14 **Identification Label** - Each shirt shall have a durable blank label 7.5cm x 2cm applied separately below the marking and cleaning label used for the inscription of the wearers' name.
- 4.3.15 **Marking & Cleaning Instructions Label** - Each shirt shall have a cloth label affixed to the back of the neckband or side seam. The label information shall be as outlined below in a font no less than size 8. The text shall be permanent ink in a contrasting colour and shall withstand at least 50 washes showing no apparent change in appearance. The label shall be completed in accordance with the following information in English and French.
1. Item name in English and French as written in para. 1.1, as applicable.
 2. RCMP stock number - reference contract documents. (Ex. 6047 000)
 3. Size of the article, combining the size designation referenced in the English and French contract documents. (Ex. Small/Petit, X-Large/T Grand)
 4. Date of manufacturer, in numeric format year/month (Ex. 2001/11)
 5. Your manufacturer identification (Company name or number).
 6. Print information as written below.

- 7. Print information as written below.
- 8. Print information as written below.
- 9. Print information as written below.

1
2
3
4
5
6
7
8
9

RCMP-GRC #
Size

Machine wash cool / Lavage à l'eau froide
Do Not use fabric softener or chlorine bleach / **Ne pas** utiliser d'agent adoucissant ou d'agent de blanchiment
 Tumble dry –low (**Do not** use dryer sheets) / Séchage par culbutage – à basse température (**Ne pas** utiliser d'assouplissant en feuilles)
 Steam Iron - Medium temperature / Repassage à vapeur - à température moyenne
 Do Not dry clean / Ne pas nettoyer à sec

Note: The manufacturers identification shall not appear anywhere on the garment except on the garment label as indicated.

5. **Quality Assurance Provisions**

- 5.1 **Responsibility for Inspection** - Unless otherwise stipulated in the contract, it is the prime contractor's responsibility to satisfy the RCMP, Uniform and Equipment Program that the material and services being supplied conform to this specification. This may be accomplished by performing the tests specified in this specification or by demonstrating to the satisfaction of the RCMP, Uniform and Equipment Program that conformity to this specification of manufacturing processes is assured. The contractor may use any commercial testing establishment acceptable to the RCMP, Uniform and Equipment Program.
- 5.2 The RCMP, Uniform and Equipment Program reserves the right to perform any inspection considered necessary to ensure the material and services conform to the specified requirements. For the purpose of inspection, a portion of each delivery not exceeding two percent or two out of any number delivered under 100 may be put to tests that could destroy the articles. If found to be inferior or not in accordance with this specification, all articles so destroyed shall be replaced by others of proper quality and pattern at the expense of the contractor. The entire delivery may also be rejected if it is found that articles previously rejected due to non-repairable defects are redelivered for inspection.
- 5.3 The contractor will be promptly notified when any articles are not accepted and such articles will be returned at the contractor's risk and expense.

TABLE I

		REQUIREMENT	ACCEPTABLE TESTED METHODS
1	Colour	To match colour swatch provided by Uniform and Equipment Program	
2	Weave	Plain	
3	Mass	165 ± 8 g/m ² (157 - 173)	CAN/CGSB-4.2 Method 5.1-M90
4	Width	160 cm (min.)	CAN/CGSB-4.2 Method 4.1-M87
5	Yarns per 10 cm	Warp 400 (min.) Weft 210 (min.)	CAN/CGSB-4.2 Method 6-M89
6	Breaking Strength	Warp 580 Newtons (min.) Weft 230 Newtons (min.)	CAN/CGSB-4.2 Method 9.2-M90
7	Dimensional Change to Domestic Laundering	Warp 2% (max.) Weft 2% (max.)	CAN/CGSB-4.2 Method 58-2004, Wash Procedure II; Dry Procedure E; Restoration Procedure 3
8	Colourfastness to Washing	Grey Scale 4 or better	CAN/CGSB-4.2 Method 19.1-M90
9	Colourfastness to Light	At least AATCC L4	CAN/CGSB-4.2 Method 18.3-97
10	Colourfastness to Perspiration	Grey scale 4 or better	CAN/CGSB-4.2 Method 23-M90
11	Colourfastness to Rubbing (Crocking)	Dry - grey scale 3-4 or better Wet - grey scale 3 or better	CAN/CGSB-4.2 Method 22-2004
12	Water Repellency	<i>Initial</i> - 100 <i>After 3 washes</i> - 90 <i>After 20 washes</i> - 70	AATCC 35
13	Pilling	after 90 mins - no less than 4 after 120 mins - no less than 4	CAN/CGSB-4.2 Method 51.2-M87
14	Abrasion	after 5000 cycles - no less than 3-4	ASTM D4966-89
15	Crease Recovery	warp - 70% weft - 70%	CAN/CGSB-4.2 Method 45-M88
16	Non-Fibrous Material	3.1% (max.)	CAN/CGSB-4.2 Method 15
17	Fibre Blend	Polyester 65% ± 3% Cotton 35% ± 3%	

A certificate of compliance is required when Doubletex “Bounty US” 65/35 Poly/cotton is submitted for the requirement. Other manufacturers’ fabrics shall be acceptable provided they meet or exceed the requirements and provide test data for Table I excluding requirements 1, 2 and 4.

APPENDIX A

Sealed Pattern Identifier

Pattern #: G.S.1045-334
 Title: Shirt, Special Duty, Blue, Short Sleeve

Paper Patterns - Paper patterns are available from the RCMP, Uniform and Equipment Program, Ottawa Ontario, under Pattern # G.S.1045-334. Firms requested to produce Pre-contract Award Samples will be provided with the base pattern only. The full set of patterns either in individual sizes or as a graded nest will be provided to the successful bidder after the contract is awarded.

The paper patterns include seam allowances, drill holes and/or placement templates. Drill holes mark the edge of the placement. Contractors may make changes required to suit their production process, however, the design and grade shall not be affected or changed.

All patterns are the property of the RCMP and must be returned upon completion of the contract.

Pattern Pieces - This design has 13 pattern components.

Cut 1 Single =	Cut 1
Cut 1 Paired =	Cut 2
Cut 2 Paired =	Cut 4

Pattern Components	Nomenclature	Quantity to be cut	Material
1 of 13	Back	1 Single	Shell Material (RSU)
2 of 13	Front - Right	1 Single	Shell Material (RSU)
3 of 13	Front - Left	1 Single	Shell Material (RSU)
4A of 13	Buttonhole Flap - Front Left	1 Single	Shell Material (RSU)
4B of 13	Buttonhole Flap - Front Left	1 Single	Shell Material (RSU)
4C of 13	Buttonhole Flap - Front Left	1 Single	Shell Material (RSU)
5 of 13	Yoke	1 Paired	Shell Material
6 of 13	Sleeve	1 Paired	Shell Material
7 of 13	Collar	1 Paired	Shell Material
8 of 13	Pocket	1 Paired	Shell Material

Pattern Components	Nomenclature	Quantity to be cut	Material
9 of 13	Pocket Flap A	1 Paired	Shell Material
10 of 13	Pocket Flap B	1 Paired	Shell Material
11 of 13	Shoulder Strap	2 Paired	Shell Material
12 of 13	Pen Pocket	1 Paired	Shell Material
13 of 13	Shoulder Patch	1 Paired	Loop tape

Appendix B

Scale of Measurement Definitions and Location References

Refer to the Scale of Measurements and drawing #1

- A. **Chest Circumference (half only)** - When placed flat, the chest shall be the distance across the buttoned shirt, measured at the lowest point of the armholes.
- B. **Hem Circumference (half only)** - When placed flat, the hem shall be the distance across the buttoned shirt, measured in a straight line from the lowest point on the side seam.
- C. **Back Length** - The length shall be the distance measured from the base of the collar at center back of the neck to the bottom of the shirt.
- D. **Back Width** - The back width shall be the distance across the back of the shirt measured at the bottom of the yoke.
- E. **Side Length** - The distance measured from the lowest point of the armhole to the bottom edge of the hem.
- F. **Neck Circumference** - The neckline circumference shall be the distance measured along the neck line from collar end to end.
- G. **Sleeve Overarm** - The overarm sleeve length shall be the distance from the armhole at the shoulder point to the sleeve hem.
- H. **Sleeve Hem Width (half only)** - When placed flat, the sleeve hem width shall be the measurement of the bottom edge of the sleeve.
- J. **Shoulder Strap** - The shoulder strap shall be the distance measured from the tip to the shoulder seam.
- K. **Depth of Yoke** - The yoke depth shall be the distance measured from the collar seam at the center back to the bottom of the yoke.

Scale of Measurements - Shirt, Special Duty, Blue, Short Sleeve												
Size Designation		Body Measurements	Garment Measurements(cm)									
Height	Size	Chest(Inches)	Chest Circ (half only)	Hem Circ (half only)	Back Length	Back Width	Side Length	Neckline Circ	Sleeve Overarm	Sleeve Hem Width (half only)	Shoulder Straps	Depth of Yoke
Short	XXS	31 - 33	49	46.25	68	41	36	41.25	21.5	22.5	14	7.25
	XS	34 - 36	52.75	50	70	43.5	37	42	22	22.5	14.75	8.25
	S	37 - 39	56.5	53.75	72	46	38	43.25	22.5	22.75	15.5	9.25
	M	40 - 42	60.25	57.5	74	48.5	39	44.25	23.25	22.75	16.25	10.25
	L	43 - 45	64	61.25	76	51	40	45.50	23.25	23	17	11.25
	XL	46 - 48	67.75	65	78	53.5	41	46.50	24.25	23.25	17.75	12.25
	2XL	49 - 51	71.5	68.75	80	56	42	47.75	24.75	23.25	18.5	13.25
	3XL	52 - 54	75.25	72.5	82	58.5	43	48.75	25.25	23.5	19.25	14.25
	4XL	55 - 57	79	76.25	84	61	44	50.00	26	23.5	20	15.25
Regular	XXS	31 - 33	49	46.25	73	41	41	41.25	23.5	22.5	14	7.25
	XS	34 - 36	52.75	50	75	43.5	42	42.25	24	22.5	14.75	8.25
	S	37 - 39	56.5	53.75	77	46	43	43.25	24.5	22.75	15.5	9.25
	M	40 - 42	60.25	57.5	79	48.5	44	44.25	25.25	22.75	16.25	10.25
	L	43 - 45	64	61.25	81	51	45	45.50	25.75	23	17	11.25
	XL	46 - 48	67.75	65	83	53.5	46	46.50	26.25	23.25	17.75	12.25
	2XL	49 - 51	71.5	68.75	85	56	47	47.75	26.75	23.25	18.5	13.25
	3XL	52 - 54	75.25	72.5	87	58.5	48	48.75	27.25	23.5	19.25	14.25
	4XL	55 - 57	79	76.25	89	61	49	50.00	28	23.5	20	15.25
5XL	58 - 60	82.75	80	91	63.5	50	51.25	28.5	23.75	20.75	16.25	
Tolerance ±			1.5 cm	1.5 cm	1.5 cm	1.5 cm	1.5 cm	1 cm	1.5 cm	1 cm	0.5 cm	0.5 cm
Measurement Location			A	B	C	D	E	F	G	H	J	K

Note: All measurements are in centimetres unless otherwise specified.

<u>Scale of Measurements</u> - Shirt, Special Duty, Blue, Short Sleeve												
Size Designation		Body Measurements	Garment Measurements(cm)									
Height	Size	Chest(Inches)	Chest Circ (half only)	Hem Circ (half only)	Back Length	Back Width	Side Length	Neckline Circ	Sleeve Overarm	Sleeve Hem Width (half only)	Shoulder Straps	Depth of Yoke
Tall	XXS	31 - 33	49	46.25	78	41	46	41.5	25.5	22.5	14	7.25
	XS	34 - 36	52.75	50	80	43.5	47	42.5	26	22.5	14.75	8.25
	S	37 - 39	56.5	53.75	82	46	48	43.5	26.5	22.75	15.5	9.25
	M	40 - 42	60.25	57.5	84	48.5	49	44.5	27.25	22.75	16.25	10.25
	L	43 - 45	64	61.25	86	51	50	45.5	27.75	23	17	11.25
	XL	46 - 48	67.75	65	88	53.5	51	46.75	28.25	23.25	17.75	12.25
	2XL	49 - 51	71.5	68.75	90	56	52	48	28.75	23.25	18.5	13.25
	3XL	52 - 54	75.25	72.5	92	58.5	53	49.25	29.25	23.5	19.25	14.25
	4XL	55 - 57	79	76.25	94	61	54	50.5	30	23.5	20	15.25
5XL	58 - 60	82.75	80	96	63.5	55	51.5	30.5	23.75	20.75	16.25	
Tolerance ±			1.5 cm	1.5 cm	1.5 cm	1.5 cm	1.5 cm	1 cm	1.5 cm	1 cm	0.5 cm	0.5 cm
Measurement Location			A	B	C	D	E	F	G	H	J	K

Note: All measurements are in centimetres unless otherwise specified.

SHIRT, SPECIAL DUTY, BLUE, SHORT SLEEVE

G.S.1045-334

MEASUREMENT LOCATION CHART

Dwg. 1

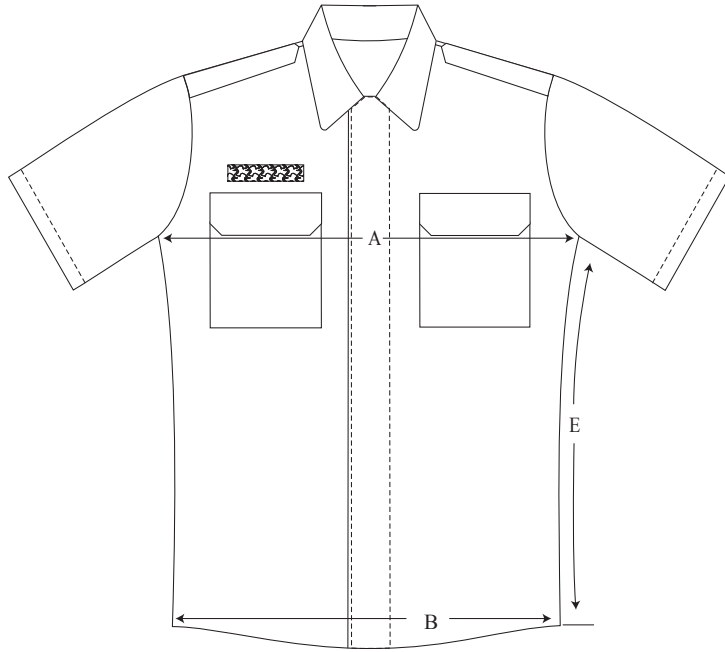

Front View

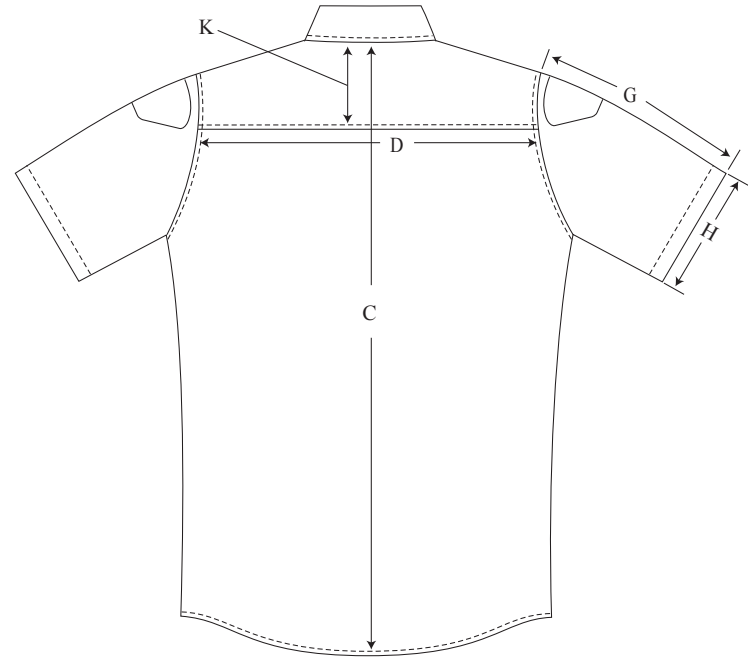

Back View

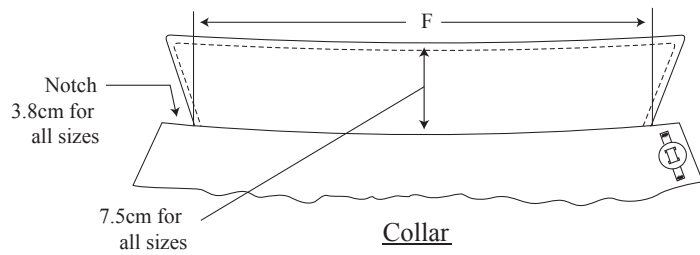

Collar

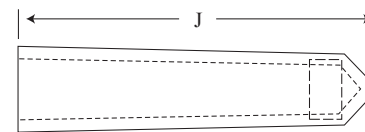

Shoulder Strap

NOT TO SCALE

SHIRT, SPECIAL DUTY, BLUE, SHORT SLEEVE

G.S.1045-334

Dwg. 2

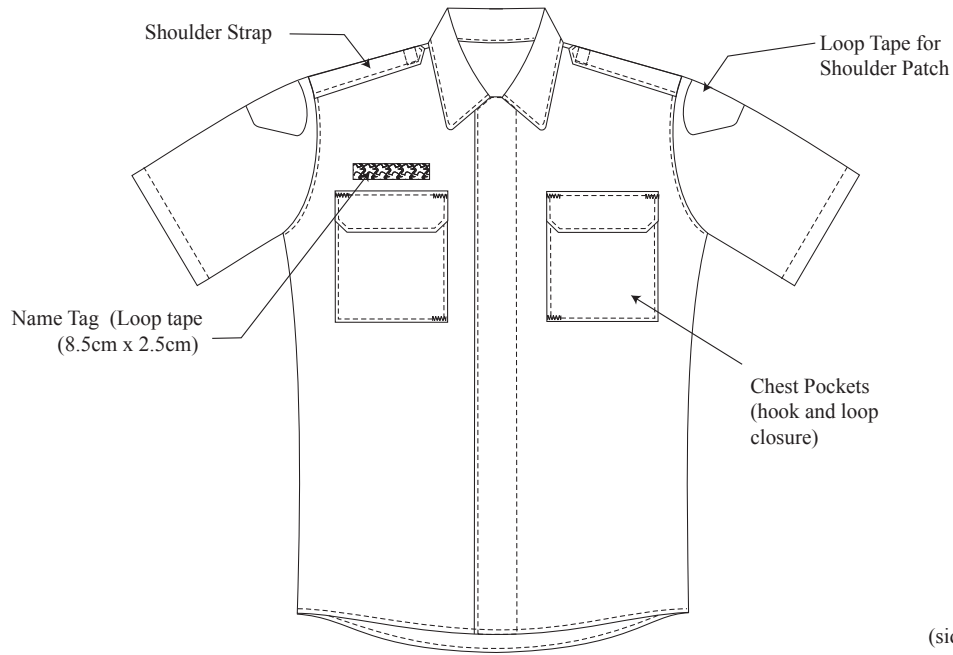

Front View

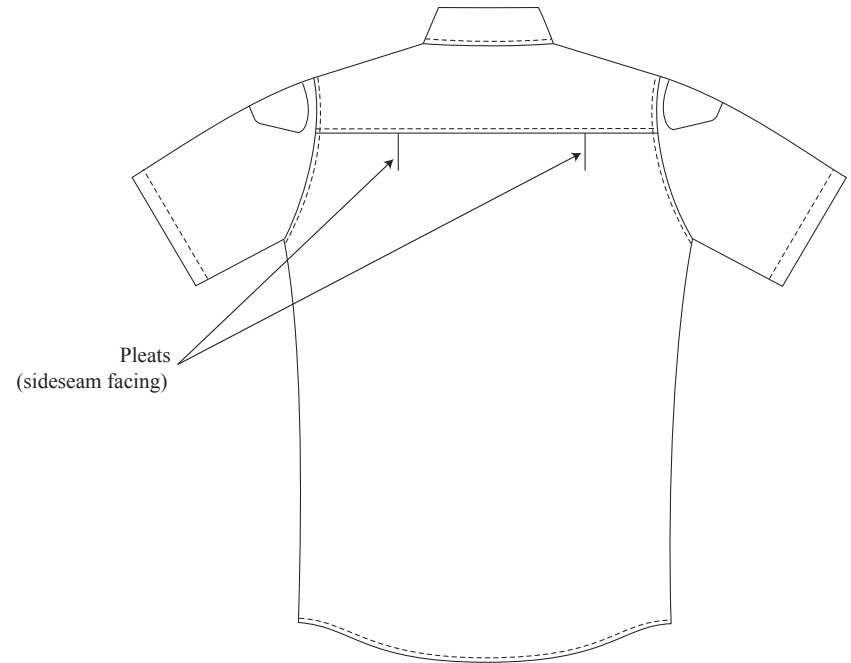

Back View

All Measurements in Centimetres
NOT TO SCALE
± 0.5cm tolerance acceptable unless otherwise indicated.

Dwg. 3

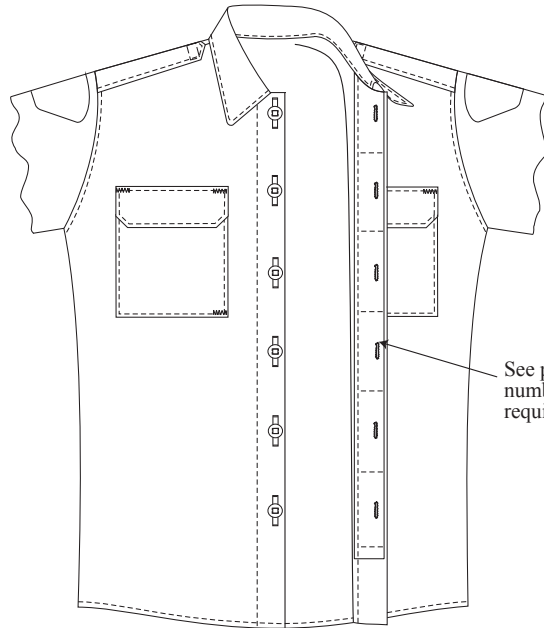

Front Placket Detail

See para. 4.3.3.1 for number of buttonholes required

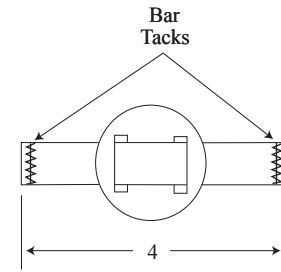

Military Strap Button with Strap

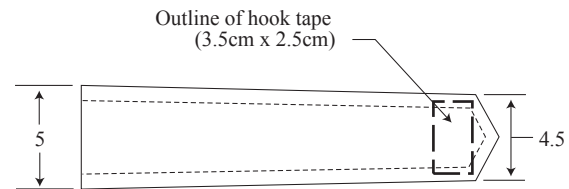

Shoulder Strap

All Measurements in Centimetres
NOT TO SCALE
± 0.5cm tolerance acceptable unless otherwise indicated.

Chest Pocket Detail

Dwg. 4

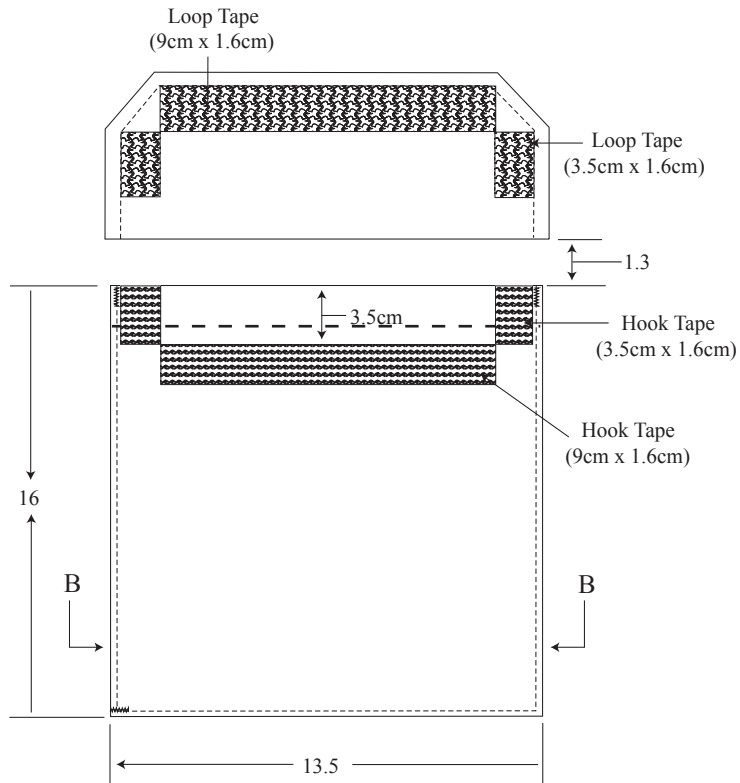

Left Chest Pocket

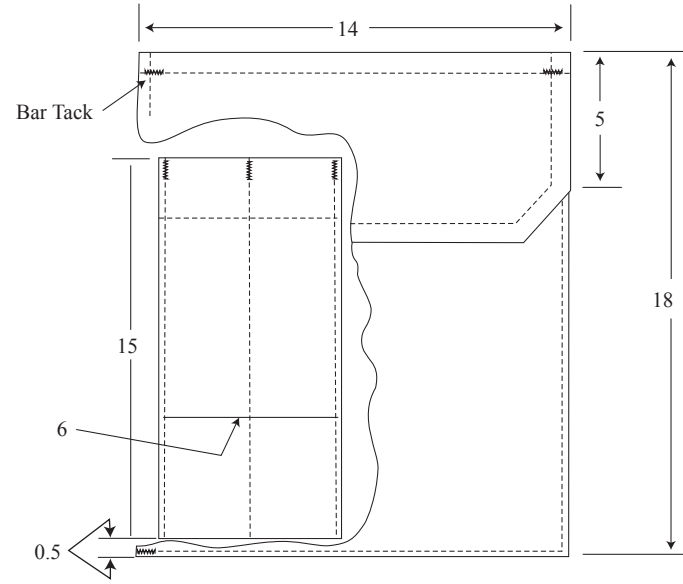

Left Chest Pocket
(showing Pen Pocket)

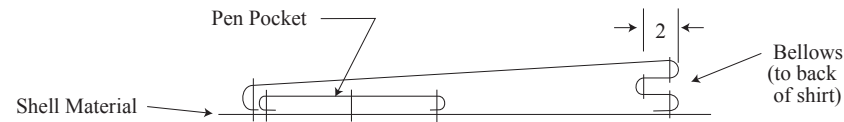

Section B-B
Left Chest Pocket & Pen Pocket

All Measurements in Centimetres
NOT TO SCALE
± 0.5cm tolerance acceptable unless otherwise indicated.