

- GENERAL NOTES:**
- REINSTATE ALL DISTURBED AREAS WITH 100mm TOPSOIL AND SEED AND MULCH.
  - CONTRACTOR TO RECORD EXISTING ASPHALT AND CURB ELEVATIONS, SLOPES AND CROSSFALLS AT MINIMUM 10m INTERVALS PRIOR TO REMOVAL OF EXISTING CONCRETE CURB AND ASPHALT PAVEMENT.
  - REMOVE, SALVAGE AND RE-INSTALL ALL PARKING LOT SIGNAGE AS REQUIRED TO SUIT THE CONTRACTOR'S OPERATIONS.

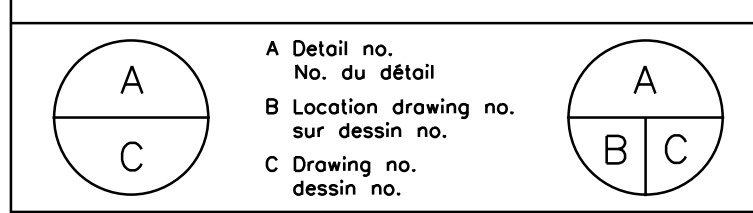

No.	Description	By	Date (dd/mm/yy)
0	ISSUED FOR TENDER	PH	30/06/15

- Verify all dimensions and site conditions and be responsible for same
- Vérifier toutes les dimensions et l'état des lieux et en assumer la responsabilité



project / projet  
**MONTREAL CAMPUS BUILDING M9 PARKING LOT REHABILITATION**

drawing / dessin  
**REMOVALS AND ADJUSTMENTS**

designed / conçu	P.H.	date	JUNE 2015
drawn / dessiné	M.S.	scale / échelle	1:200
checked / vérifié	P.H.	sheet / feuille	R1 of/de R5
approved / approuvé	P.H.	W.O.no. / D.T.no.	A1-006892-01-02
dwg.no. / dessin no.	D-5071-REM		





**GENERAL NOTES:**  
 1. REINSTATE ALL DISTURBED AREAS WITH 100mm TOPSOIL AND SEED AND MULCH  
 2. MAINTAIN EXISTING SLOPES AND CROSSFALLS. CONTRACTOR TO ENSURE POSITIVE DRAINAGE AS INDICATED ON DWG. NO. R2.

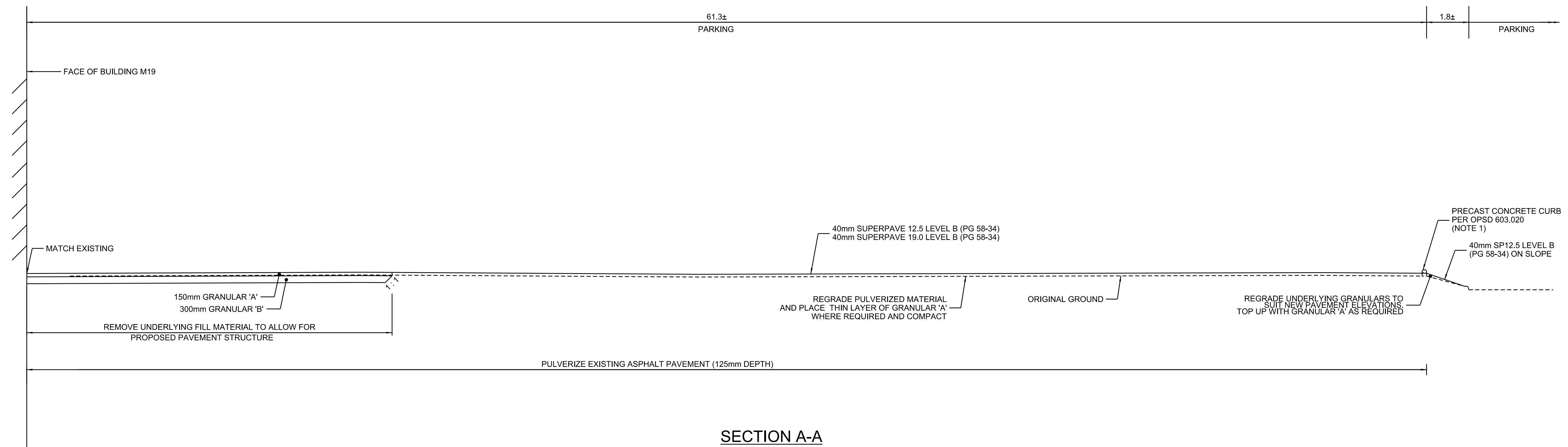

**SECTION A-A**

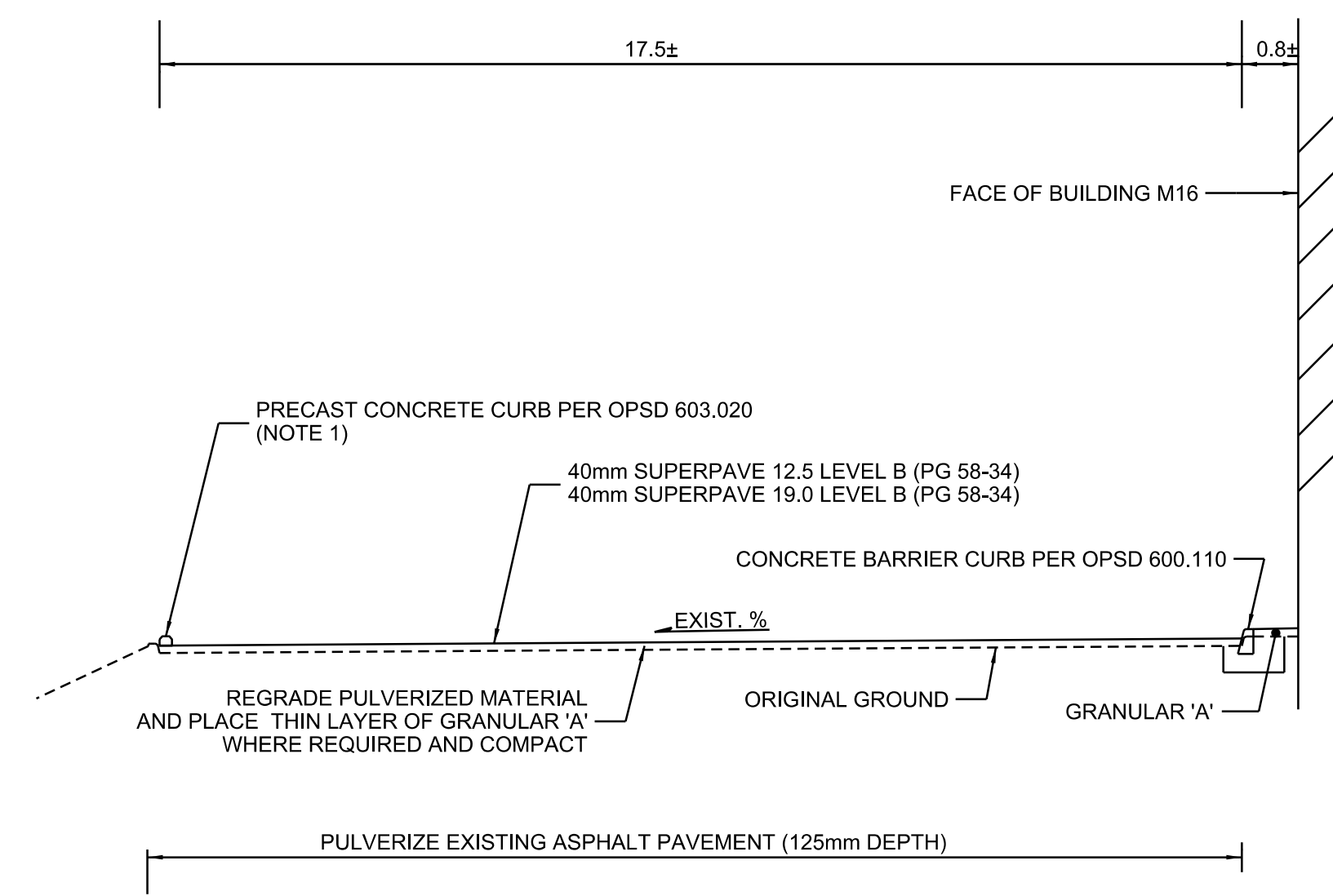

**SECTION B-B**

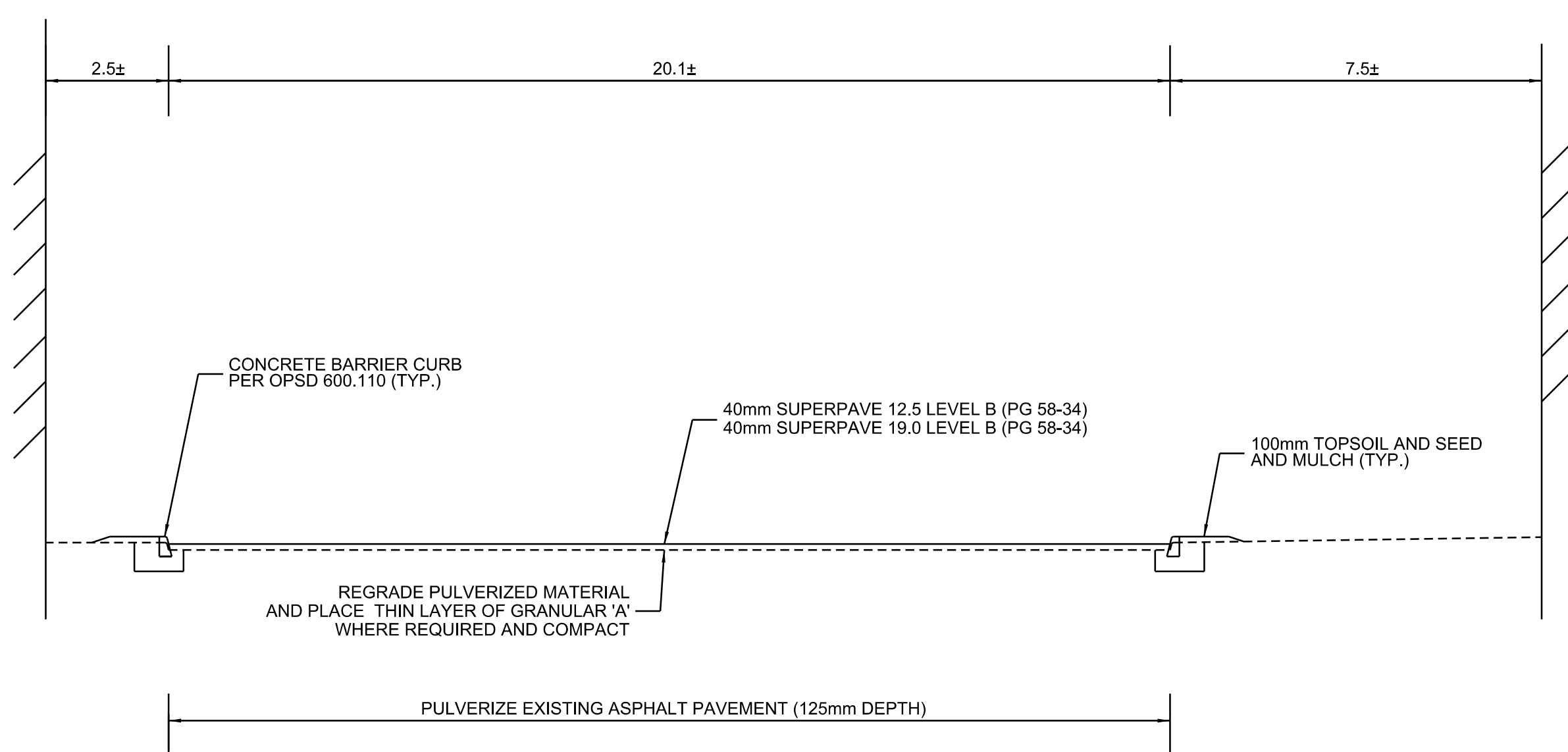

**SECTION C-C**



No.	Description	By	Date (dd/mm/yy)
0	ISSUED FOR TENDER	PH	30/06/15

o Verify all dimensions and site conditions and be responsible for same  
 o Vérifier toutes les dimensions et l'état des lieux et en assumer la responsabilité

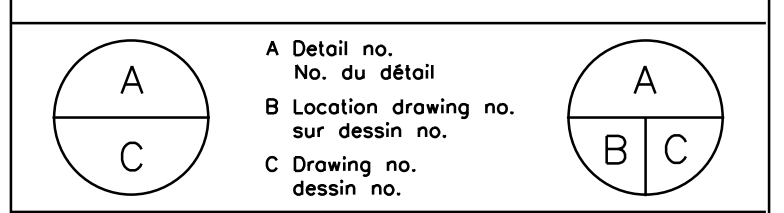

project / projet  
**MONTREAL CAMPUS BUILDING M19 PARKING LOT REHABILITATION**

drawing / dessin  
**TYPICAL SECTIONS 1**

designed / conçu	P.H.	date	JUNE 2015	date	
drawn / dessiné	M.S.	scale	1:200	échelle	
checked / vérifié	P.H.	sheet / feuille	R3 of/de	R5	
approved / approuvé	P.H.	W.O.no.	A1-006892-01-02	D.T.no.	
dwg.no.	D-5071-TXS		dessin no.		



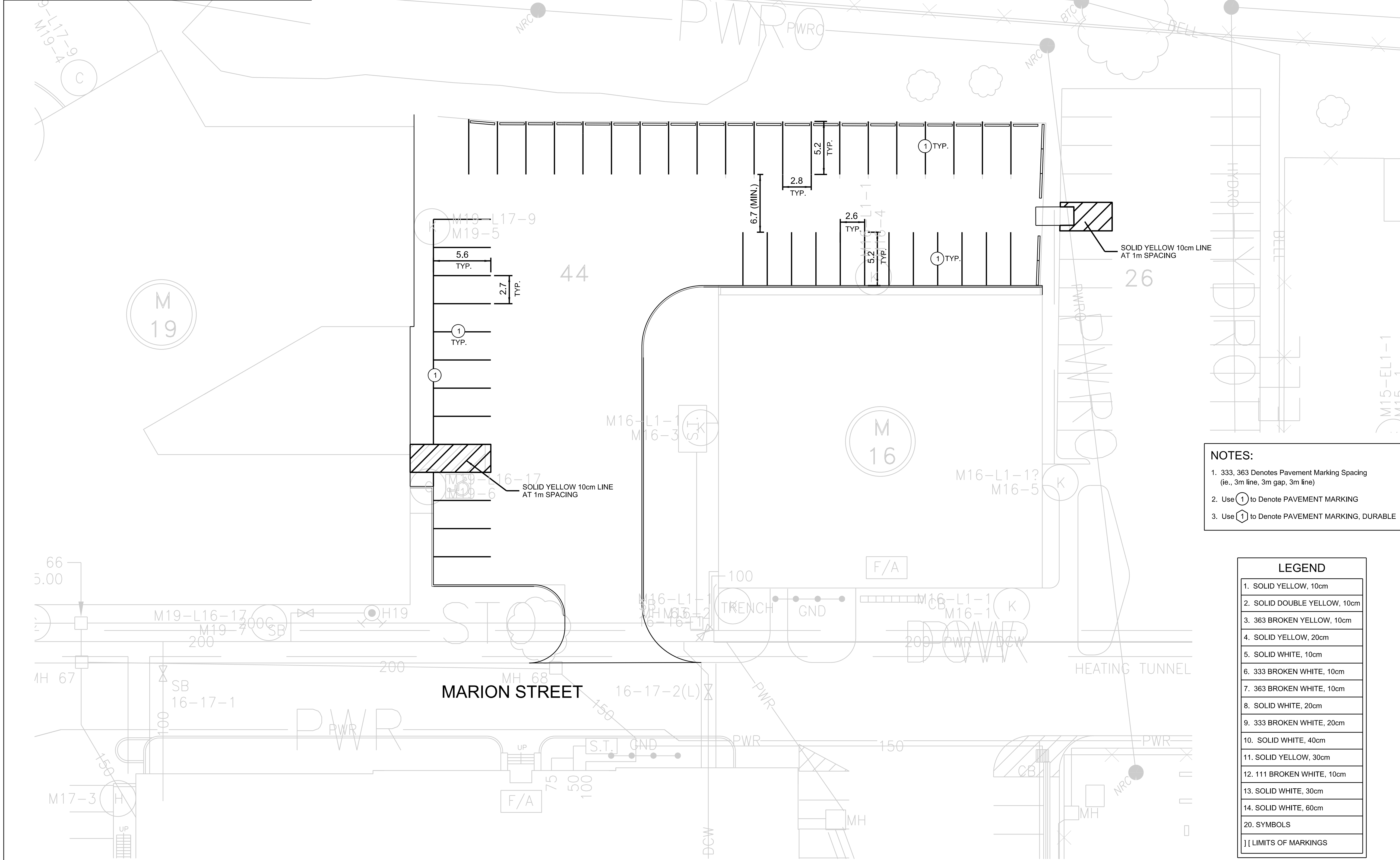
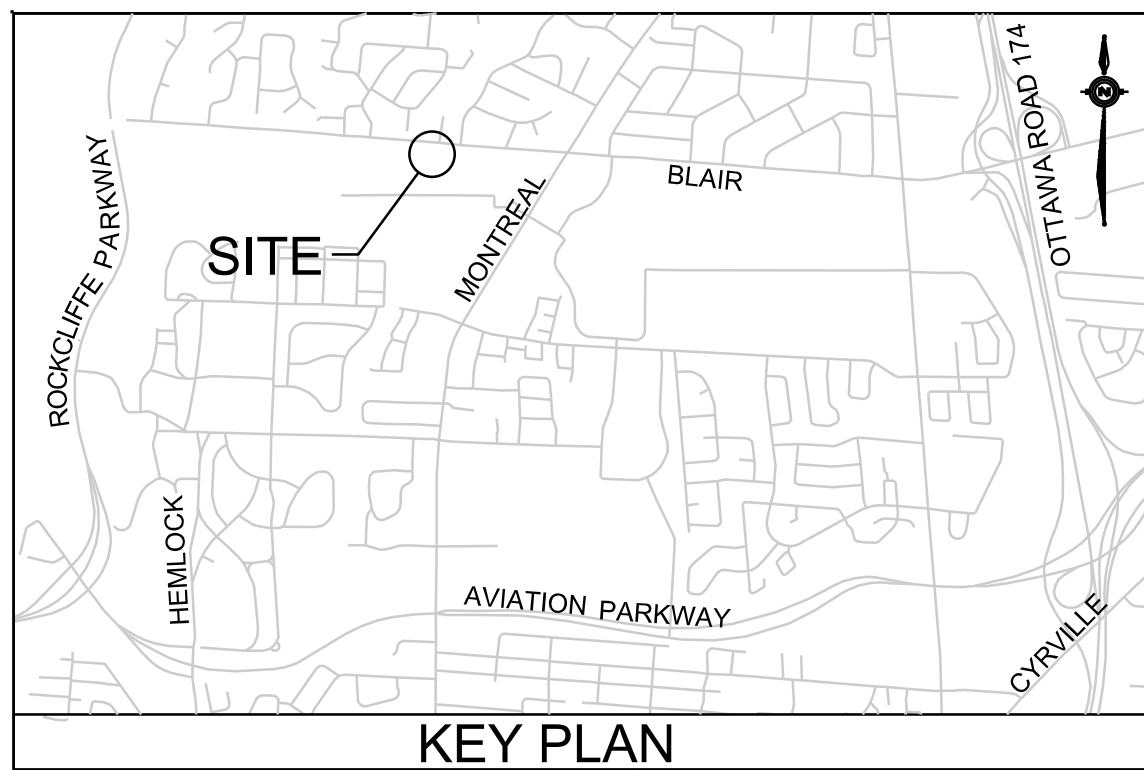

**GENERAL NOTES:**  
 1. REINSTATE ALL DISTURBED AREAS WITH 100mm TOPSOIL AND SEED AND MULCH.



No.	Description	By	Date (dd/mm/yy)
0	ISSUED FOR TENDER	PH	30/06/15

o Verify all dimensions and site conditions and be responsible for same  
 o Vérifier toutes les dimensions et l'état des lieux et en assumer la responsabilité

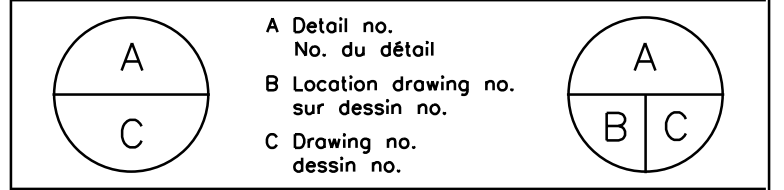

project **MONTREAL CAMPUS BUILDING M9 PARKING LOT REHABILITATION** projet

drawing **PAVEMENT MARKINGS** dessin

designed <b>P.H.</b>	conçu <b>JUNE 2015</b>	date	date
drawn <b>M.S.</b>	dessiné	scale <b>1:200</b>	échelle
checked <b>P.H.</b>	vérifié	sheet <b>R4</b>	of/de <b>R5</b>
approved <b>P.H.</b>	approuvé	W.O.no. <b>A1-006892-01-02</b>	D.T.no.
dwg.no. <b>D-5071-TPM</b>		dessin no.	

**NOTES:**  
 1. 333, 363 Denotes Pavement Marking Spacing (ie., 3m line, 3m gap, 3m line)  
 2. Use (1) to Denote PAVEMENT MARKING  
 3. Use (1) to Denote PAVEMENT MARKING, DURABLE

**LEGEND**

1. SOLID YELLOW, 10cm
2. SOLID DOUBLE YELLOW, 10cm
3. 363 BROKEN YELLOW, 10cm
4. SOLID YELLOW, 20cm
5. SOLID WHITE, 10cm
6. 333 BROKEN WHITE, 10cm
7. 363 BROKEN WHITE, 10cm
8. SOLID WHITE, 20cm
9. 333 BROKEN WHITE, 20cm
10. SOLID WHITE, 40cm
11. SOLID YELLOW, 30cm
12. 111 BROKEN WHITE, 10cm
13. SOLID WHITE, 30cm
14. SOLID WHITE, 60cm
20. SYMBOLS
] [ LIMITS OF MARKINGS

- GENERAL NOTES:**
- OVERALL HEIGHT OF STAIRS IS BASED ON EXISTING ELEVATION DIFFERENCE BETWEEN UPPER AND LOWER PARKING LOTS PLUS AN ALLOWANCE FOR PULVERIZING AND RE-PAVING OF THE UPPER LOT. CONTRACTOR TO VERIFY GRADES PRIOR TO CONSTRUCTION OF STAIRS.
  - CONTRASTING COLOUR BAND TO BE INSTALLED ON EACH STAIR NOSING.

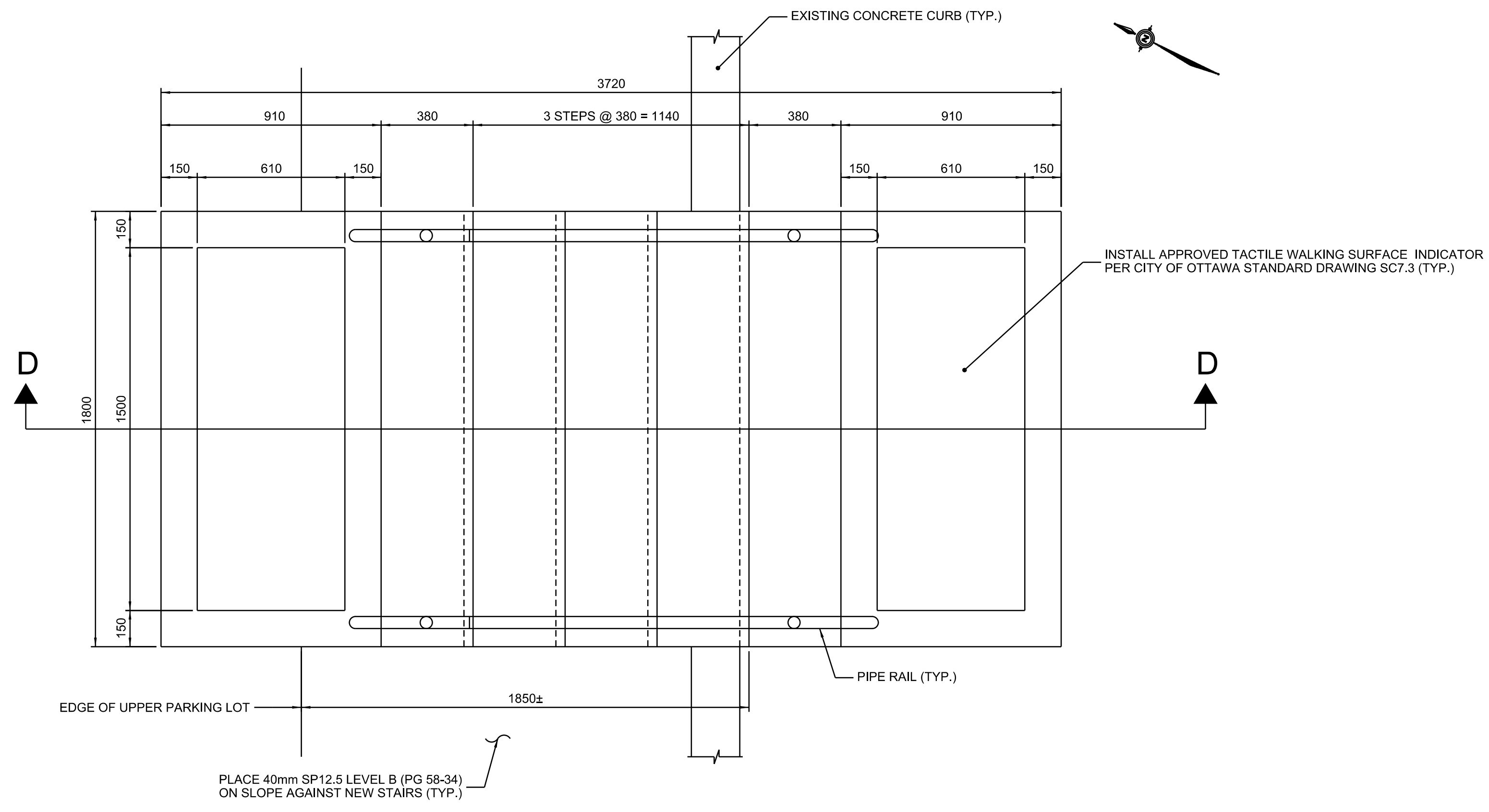

**PLAN**  
1:15

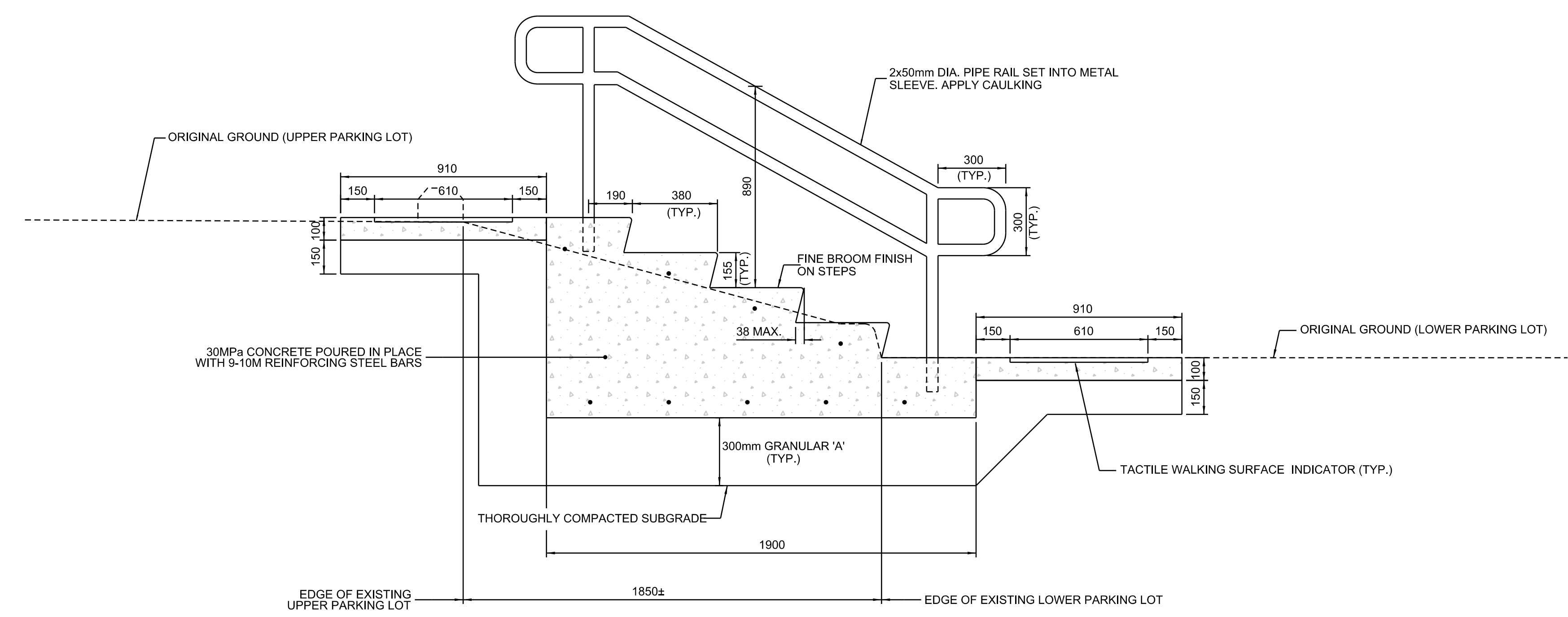

**SECTION D-D**  
1:15



No.	Description	By	Date (dd/mm/yy)
0	ISSUED FOR TENDER	PH	30/06/15

- Verify all dimensions and site conditions and be responsible for same
- Vérifier toutes les dimensions et l'état des lieux et en assumer la responsabilité

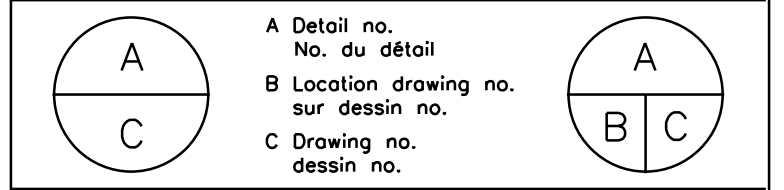

project **MONTREAL CAMPUS BUILDING M9 PARKING LOT REHABILITATION** projet

drawing **DETAILS** dessin

designed	P.H.	conçu	date	JUNE 2015	date
drawn	M.S.	dessiné	scale	AS NOTED	échelle
checked	P.H.	vérifié	sheet	R5 of/de R5	feuille
approved	P.H.	approuvé	W.O.no.	A1-006892-01-02	D.T.no.
dwg.no.	D-5071-DTL		dessin no.		