



Fisheries  
and Oceans

Pêches  
et Océans

## **INVITATION TO TENDER**

**KANAKA SMALL CRAFT HARBOUR**

**Electrical Reconstruction**

**F1571-155032/A**

Fisheries and Oceans Canada reserves the right to reject any and all bids and the lowest bid will not necessarily be accepted.

**Canada**

<b>Table of Contents</b>		
<b>Division 01 General</b>	<b>Description</b>	<b>Page</b>
01 00 10	General Instructions	14
01 00 11	Summary of Work	10
01 35 29	Health and Safety Requirements	4
<b>Division 26 Electrical</b>		
26 05 01	Electrical General Requirements	14
26 05 21	Wires, Cables and Connectors (0 – 1000V)	4
26 05 28	Grounding - Secondary	3
26 05 29	Hangars & Supports for Electrical Systems	2
26 05 34	Conduit, Conduit Fastenings & Fittings	2
26 05 36	Cable Trays	3
26 12 19	Luminaires	2
26 24 16	Panelboard – Breaker Type	4
26 24 17.01	MDP Enclosure and Components	4
26 24 17.02	RC Enclosures and Components	2
26 27 16	Outdoor Equipment Enclosures	2
26 27 26	Wiring Devices	1
<b>Division 26 Electrical Drawings</b>		
E-1	Site Plan Existing and Proposed General Electrical Layout	1
E-2	Single Line Diagram, Panel Schedules, and Load Calculations	1
E-3	Electrical Details	1
E-4	Receptacle Cabinet (RC) and Float Details	1
<b>Appendix 1 - Aluminum Kiosk Drawings</b>		
AK-001	Aluminum Kiosk	1
AK-002	Aluminum Kiosk	1
AK-003	Aluminum Kiosk	1
AK-004	Aluminum Kiosk	1

**1 GENERAL**

**1.1 SECTION INCLUDES**

- .1 Location
- .2 Description of work
- .3 Enquiries
- .4 Documents required
- .5 Time of completion
- .6 Work schedule
- .7 Cost breakdown
- .8 Contractor's use of site
- .9 Codes and standards
- .10 Location of equipment and fixtures
- .11 Safety regulations and measures
- .12 Concealment
- .13 Cutting, fitting, and patching
- .14 Existing connecting services
- .15 Alterations to existing building
- .16 Drawings
- .17 As-built drawings
- .18 Material and equipment
- .19 Shop drawings, product data, and samples
- .20 Operation and maintenance manuals
- .21 Environmental protection

- .22 Cleaning
- .23 Regulatory requirements
- .24 Temporary facilities
- .25 Condition of structure
- .26 Materials supplied by Owner
- .27 Insurance

**1.2 LOCATION**

- .1 The Kanaka Small Craft Harbour is located on MacKay Ave, in Maple Ridge, B.C.

**1.3 DESCRIPTION OF WORK**

- .1 For Summary of Work and additional requirements, refer to Section 26 05 01 - Electrical General Requirements.

**1.4 ENQUIRIES**

- .1 Enquiries are made through the contracting officer as information as indicated in the solicitation document.

**1.5 DOCUMENTS REQUIRED**

- .1 Maintain 1 copy each of the following at the job site:
  - .1 Contract drawings.
  - .2 Contract specifications.
  - .3 Addenda to Contract documents.
  - .4 Reviewed shop drawings.
  - .5 Change orders.
  - .6 Other modifications to Contract.
  - .7 Field test reports.
  - .8 Copy of approved work schedule.

- .9 Manufacturer's installation and application instructions.

## **1.6 TIME OF COMPLETION**

- .1 Start work immediately upon official notification of acceptance of offer.
- .2 Work to be completed by November 30<sup>th</sup>, 2015.

## **1.7 WORK SCHEDULE**

- .1 Within 7 working days after Contract award, provide a schedule showing anticipated progress stages and final completion of the work within the time period required by Contract documents.
- .2 Interim reviews of work progress based on work schedule will be conducted as decided by Engineer and schedule updated by Contractor in conjunction with and to approval of Engineer.

## **1.8 COST BREAKDOWN**

- .1 Before submitting first progress claim, submit breakdown of Contract price in detail as directed by Engineer and aggregating contract price. After approval by Engineer, cost breakdown will be used as basis for progress payment.

## **1.9 CONTRACTOR'S USE OF SITE**

- .1 Cooperate with other users and contractors on site to minimize interference.
- .2 Do not unreasonably encumber site with materials or equipment.
- .3 Move stored products or equipment which interferes with operations of the Engineer, harbour master, other contractors, or Harbour users.
- .4 Obtain and pay for the use of additional storage or work areas needed for operations.
- .5 Hours of work:
  - .1 Perform work during normal working hours of the wharf occupants, Monday through Friday (except holidays). Provide schedule for prior approval by Engineer, harbour master and owner.
  - .2 Work may be performed on weekends and holidays with the prior approval of the Engineer, harbour master and owner.

- .6 Do not interfere with harbour operations.

#### **1.10 CODES AND STANDARDS**

- .1 Perform work in accordance with:
  - .1 Canada Labour Code, Canada Occupational Safety and Health Regulations.
  - .2 Fire Commissioner of Canada (FCC):
    - .1 FCC No. 301-1982, Standard for Construction Operations.
    - .2 FCC No. 302-1982, Standard for Welding and Cutting.
  - .3 National Research Council (NRC):
    - .1 National Building Code of Canada (NBC) 2010.
  - .4 Province of British Columbia:
    - .1 Workers Compensation Act (Occupational Health and Safety), Amendment Act, B.C. Reg. 185/99, herein referred to as the Workers Compensation Act (WCA).
  - .5 CSA C22.1-12 Canadian Electrical Code.
- .2 If there is a conflict between codes or standards the more stringent requirement shall apply.

#### **1.11 LOCATION OF EQUIPMENT AND FIXTURES**

- .1 Locations of equipment, fixtures, and outlet equipment as indicated or specified are to be as shown. If not detailed, locations are approximate.
- .2 Locate equipment, fixtures and distribution systems to provide minimum interference and maximum usable space and in accordance with the manufacturer & owner's recommendations for safety, access and maintenance.
- .3 Inform Engineer and owner of impending installation and obtain approval for actual location.
- .4 Submit field drawings to indicate position of various services and equipment when required by Engineer.

**1.12 SAFETY REGULATIONS AND MEASURES**

- .1 Construction safety:
  - .1 Observe and enforce construction safety measures required by the following:
    - .1 NBC 2010, Part 8 - Safety Measures at Construction and Demolition Sites.
    - .2 B.C. Provincial Government.
    - .3 Workers' Compensation Board of B.C.
    - .4 Municipal statutes and authorities.
  - .2 In event of conflict between any provisions of the above authorities, the most stringent provision will apply.
  - .3 Ensure no part of work is subjected to a load which will endanger its safety or will cause permanent deformation.
- .2 Workers' Compensation Board coverage:
  - .1 Comply fully with the Workers' Compensation Act, regulations and orders made pursuant thereto, and any amendments up to the completion of the work.
  - .2 Maintain Workers' Compensation Board coverage during the term of the Contract, until and including the date that the Final Certificate of Completion is signed.
- .3 Compliance with regulations:
  - .1 Small Craft Harbours may terminate the Contract without liability to SCH where the Contractor, in the opinion of SCH, refuses to comply with a requirement of the Workers' Compensation Act or the Occupational Health and Safety Regulations.
  - .2 It is the Contractor's responsibility to ensure that all workers are qualified, competent and certified to perform the work as required by the Workers' Compensation Act or the Occupational Health and Safety codes, standards and regulations.

- .4 Electrical safety requirements:
  - .1 Comply with local authorities and ensure that, when installing new facilities or modifying existing facilities, all electrical personnel are completely familiar with existing and new electrical circuits and equipment and their operation.
  - .2 Before undertaking any work, coordinate required energizing and de-energizing of new and existing circuits with the Engineer.
  - .3 Maintain electrical safety procedures and take necessary precautions to ensure safety of all personnel working under this Contract, as well as safety of other personnel on site.
  
- .5 Electrical lock-out:
  - .1 Develop, implement and enforce use of established procedures to provide electrical lock-out and to ensure the health and safety of workers for every event where work must be done on any electrical circuit or facility.
  - .2 Prepare lock-out procedures in writing, listing step-by-step processes to be followed by workers, including how to prepare and issue the request/authorization form. Have the procedures available for review upon request by Engineer.
  - .3 Keep documents and lock-out tags at the site and list in a log book for the full duration of the Contract. Upon request, make such data available for viewing by the Engineer or by any authorized safety representative.

**1.13 CONCEALMENT**

- .1 Conceal pipes, ducts, cables, and wiring in construction of finished areas and floats except where indicated otherwise.

**1.14 CUTTING, FITTING AND PATCHING**

- .1 Execute cutting (including excavation), fitting, and patching required to make work fit properly together.
- .2 Where new work connects with existing and where existing work is altered, cut, patch, and make good to match existing work.
- .3 Obtain Engineer's approval before cutting.



- .4 Make cuts with clean, true, smooth edges. Make patches inconspicuous in final assembly.
- .5 Where work requires the removal and replacement of timbers, including decking, do not cut timbers. Remove fasteners separately and remove and replace timbers as existing.

#### **1.15 EXISTING CONNECTING SERVICES**

- .1 Where work involve breaking into or connecting to existing services, carry out work at times directed by governing authorities, with minimum of disturbance to pedestrian and vehicular traffic.
- .2 Before starting work, establish location and extent of service lines in areas of work and notify Engineer of findings.
- .3 Submit schedule to and obtain approval from Engineer for any shutdown or closure of active service or facility. Adhere to the approved schedule and provide notice to affected parties.
- .4 Where unknown services are encountered, immediately advise Engineer and confirm findings in writing.
- .5 Remove abandoned service lines. Cap or otherwise seal lines at cut-off points as directed by Engineer.
- .6 Record locations of maintained, re-routed and abandoned service lines.

#### **1.16 ALTERATIONS TO EXISTING BUILDING**

- .1 Execute work with least possible interference or disturbance to occupants, public and normal use of premises. Arrange with Engineer, harbour master and owner to facilitate execution of work.
- .2 Where security has been reduced by work of Contract, provide temporary means to maintain security.
- .3 Provide warning signs in locations where renovation and alteration work is adjacent to areas used by public or government staff.

**1.17 DRAWINGS**

- .1 The drawings and documents listed in Section 00 01 10 shall be considered part of this contract. These drawings shall be used as a reference; the Contractor shall ensure correct dimensions.
- .2 The Engineer may furnish additional drawings to assist proper execution of the work. These drawings will be issued for clarification only and have the same meaning and intent as if they were included with plans referred to in Contract Documents.

**1.18 AS-BUILT DRAWINGS**

- .1 As work progresses, maintain accurate records to show all deviations from the Contract Drawings. Note on as-built drawings as changes occur, and, at completion, supply one (1) set of all drawings and specifications with all deviations clearly marked.

**1.19 MATERIAL AND EQUIPMENT**

- .1 Use new material and equipment unless otherwise specified.
- .2 Within 7 days of Engineer's written request, submit the following information for any or all materials and products proposed for supply:
  - .1 Name and address of manufacturer.
  - .2 Trade name, model and catalogue number.
  - .3 Performance, descriptive and test data.
  - .4 Manufacturer's installation or application instructions.
  - .5 Evidence of arrangements to procure.
- .3 Provide material and equipment of specified design and quality, performing to published ratings and for which replacement parts are readily available.
- .4 Use products of one manufacturer for equipment or material of same type or classification unless otherwise specified.
- .5 Contractor's options for selection of materials for tendering: refer to Section 26 05 01, article 1.14.
- .6 Substitution after Contract award:

- 
- .1 No substitutions will be permitted without prior written approval of the Engineer.
  - .2 Proposals for substitution may only be submitted after Contract award. Such request must include statements of respective costs of items originally specified and the proposed substitution.
  - .3 Proposals will be considered by Engineer if:
    - .1 Materials selected by tenderer from those specified are not available;
    - .2 Delivery date of materials selected from those materials specified would unduly delay completion of Contract; or
    - .3 Alternative material to that specified, which is brought to the attention of and considered by Engineer as equivalent to the material specified, and will result in a credit to the Contract amount.
  - .4 **Should the proposed substitution be accepted either in part or in whole, assume full responsibility and costs when substitution affects other work on the project. Pay for design or drawing changes required as result of substitution.**
  - .5 Amounts of all credits arising from approval of substitutions will be determined by the Engineer, and the Contract price will be reduced accordingly.
  - .7 Manufacturer's instructions:
    - .1 Unless otherwise specified, comply with manufacturer's latest printed instructions for materials and installation methods.
    - .2 Notify Engineer in writing of any conflict between these specifications and manufacturer's instructions. Engineer will designate which document is to be followed.
  - .8 Fastenings, general:
    - .1 Provide metal fastenings and accessories in same texture, colour, and finish as base metal in which they occur. **Prevent electrolytic action between dissimilar metals.** Use non-corrosive fasteners, anchors, and spacers for securing exterior work.
    - .2 Space anchors within limits of load bearing or shear capacity; ensure they provide positive permanent anchorage. Wood plugs are not acceptable.
-

- .3 Keep exposed fastenings to a minimum. Space evenly and lay out neatly.
- .4 Fastenings which cause spalling or cracking of material to which anchorage is made are not acceptable.
- .9 Fastenings, equipment:
  - .1 Use fastenings of standard commercial sizes and patterns with material and finish **suitable for service in a marine environment**.
  - .2 Use heavy hexagon heads, semi-finished unless otherwise specified. Use No. 304 stainless steel or hot dip galvanized for exterior areas.
  - .3 Bolts may not project more than 1 diameter beyond nuts.
- .10 Delivery and storage:
  - .1 Deliver, store and maintain packaged material and equipment with manufacturer's seals and labels intact.
  - .2 Prevent damage, adulteration, and soiling of material and equipment during delivery, handling and storage. Immediately remove rejected material and equipment from site.
  - .3 Store material and equipment in accordance with suppliers' instructions.
  - .4 Touch-up damaged factory finished surfaces to Engineer's satisfaction. Use primer or enamel to match original. Do not paint over nameplates.

## **1.20 SHOP DRAWINGS, PRODUCT DATA, AND SAMPLES**

- .1 Submit shop drawings, product data and samples specified to Engineer for review.
- .2 Shop drawings:
  - .1 Prepared by Contractor, subcontractor, supplier, or distributor.
  - .2 Illustrate appropriate portion of work, showing fabrication, layout, setting, or erection details as specified in appropriate sections.
- .3 Product data:
  - .1 Certain specification sections specify that manufacturer's standard schematic drawings, catalogue sheets, diagrams, schedules,

performance charts, illustrations and other standard descriptive data will be accepted in lieu of shop drawings, provided that product concerned is clearly identified.

- .2 Submit in sets, not as individual submissions.
- .4 Samples: submit in sizes and quantities specified.
- .5 Submission requirements:
  - .1 Schedule submissions at least 5 days before dates reviewed submissions will be needed.
  - .2 Submit number of copies of product data and shop drawings which Contractor requires for distribution plus copies which will be retained by Engineer.
  - .3 Accompany submissions with transmittal letter in duplicate.
- .6 Coordination of submissions:
  - .1 Review shop drawings, product data, and samples before submission.
  - .2 Coordinate with field construction criteria.
  - .3 Verify catalogue numbers and similar data.
  - .4 Coordinate each submittal with requirements of the work of all trades and the Contract documents.
  - .5 Responsibility for errors and omissions in submittals is not relieved by Engineer's review of submittals.
  - .6 Responsibility for deviations in submittals from requirements of Contract documents is not relieved by Engineer's review of submittals, unless Engineer gives written acceptance of specified deviations.
  - .7 Notify Engineer in writing, at time of submission, of deviations in submittals from the requirements of the Contract documents.
  - .8 After Engineer's review, distribute copies.

## **1.21 OPERATION AND MAINTENANCE MANUAL**

- .1 On completion of project submit to Engineer 3 copies of the operation and maintenance data as specified in various sections.

**1.22 ENVIRONMENTAL PROTECTION**

- .1 Fires and burning of rubbish on site not permitted.
- .2 Do not bury rubbish and waste materials on site unless approved by Engineer.
- .3 Do not dispose of waste or volatile materials such as oil, paint thinner or mineral spirits into waterways, storm, or sanitary sewers.
- .4 Provide temporary drainage and pumping as necessary to keep excavations and site free from water.
- .5 Control the disposal of run-off of water containing suspended materials or other harmful substances in accordance with local authority requirements.
- .6 Protect trees and plants on site and adjacent properties as designated by the Engineer.
- .7 Cover or wet down dry materials and rubbish to prevent blowing dust and debris.

**1.23 CLEANING**

- .1 Conduct cleaning and disposal operations to comply with local ordinances and anti-pollution laws.

**1.24 REGULATORY REQUIREMENTS**

- .1 Pay all fees and obtain all permits.
- .2 Provide inspection authorities with such plans and information as may be required for issue of acceptance certificates.
- .3 Furnish inspection certificates in evidence that work installed conforms with requirements of the authority having jurisdiction.

**1.25 TEMPORARY FACILITIES**

- .1 Access:
  - .1 Provide and maintain adequate access to project site.
  - .2 If authorized to use existing roads for access to project site, maintain such roads for duration of Contract. Make good any damage resulting from Contractor's use of roads.

- .2 Provide sanitary facilities for work force in accordance with governing regulations and ordinances.
- .3 Electrical power: available on site.
- .4 Scaffolding:
  - .1 Construct and maintain in a rigid, secure, and safe manner.
  - .2 Erect independent of walls.
  - .3 Remove promptly when no longer required.
- .5 Remove temporary facilities from site when directed by the Engineer, or harbour master, or owner.

**1.26 CONDITION OF STRUCTURE**

- .1 This structure was constructed many years ago. Many of the bracings, caps and other members are deteriorated from severe marine conditions. The contractor shall take precautions when removing timbers to ensure safety of workmen and the surrounding structure.

**1.27 MATERIALS SUPPLIED BY OWNER**

- .1 The Owner will supply the marine receptacle cabinet shells to be picked-up, delivered and installed by the contractor on the floats. All internal electrical components will be supplied and installed by electrical contractor.

END OF SECTION

---

**1 GENERAL**

**1.1 RELATED SECTIONS**

- .1 The following shall be deemed to be part of all Sections of the Specifications and shall be read in conjunction therewith:
  - .1 Drawings and Specifications
  - .2 Addenda and Appendices
- .2 In addition the following shall be deemed to be part of all Specifications and shall be read in conjunction therewith:
  - .1 Drawing E1: Site Plan Existing and Proposed General Electrical Layout
  - .2 Drawing E2: Single Line Diagram, Panel Schedules, and Load Calculations
  - .3 Drawing E3: Electrical Details
  - .4 Drawing E4: Receptacle Cabinet (RC) and Float Details

**1.2 DEFINITIONS**

- .1 The following terminology is used in these specifications and the intent of their meaning and use is as follows:
  - .1 The words ***Fisheries & Oceans Canada*** or ***Small Craft Harbours*** or ***DFO*** or ***SCH*** or ***Owner*** and their derivatives shall be taken to mean the person or persons employed by ***Fisheries & Oceans Canada*** and directly involved in the execution of this project.
  - .2 The words ***Engineer*** or ***Consultant*** or ***Owner's Representative*** and their derivatives shall be taken to mean the person or persons with a professional designation registered in the Province of B.C. and in good standing. The Engineer acts on behalf of and in the best interests of the Owner. The primary consultant on this project is ***WSP***.
  - .3 The words ***Departmental Representative*** and their derivatives shall be taken to mean the person or persons in the employ of the Owner who oversees the project and has final decision-making power with respect to the project and the contract.
  - .4 The words ***Contractor*** or ***Subcontractor*** and their derivatives shall be taken to mean the company that tenders and is subsequently contracted to provide the equipment and services required as defined in these



Tender documents, including the assumption of all contracts necessary for the completion of the Work described. **Contractor** or **Subcontractor** also includes those persons directly or indirectly employed or contracted or responsible to the company or companies involved in the execution of this project.

- .5 The words **Person-in-Charge** or **PIC** and their derivatives shall be taken to mean the person who is assigned by the Contractor as the on-site project supervisor and who is qualified with the requirements of the Electrical Safety Act, in good standing and approved to perform the duties of an Class A Accredited Representative in the Province of BC.
- .6 The words **Authorities Having Jurisdiction** or **AHJ** and their derivatives shall be taken to mean those persons or organizations that are responsible for approving equipment, procedures, and installation methods and can enforce requirements necessary for the safe use, procedures, installation and documentation of work.
- .7 The word **Others** and their derivatives shall be taken to mean the company(s) or person(s) that are working for the Owner on site on the project or other projects. The Contractor shall take the initiative to communicate and coordinate with Others the Work to be completed in this Project.
- .8 The words **provide** or **install** and their derivatives shall be taken to mean the procurement, supply, delivery, receipt, storage, placement, fit, connection, installation, seismically fastening, testing and commissioning of the equipment and all miscellaneous work, equipment and materials required to complete the project as stated in the contract documents.
- .9 The words **remove** and their derivatives shall be taken to mean electrical isolation of the device(s) following all safety procedures to ensure de-energization of the device, notification to Owner & Others working on the project or in the area, disconnecting all connections, proper termination & labelling of disconnected conduit/cables/boxes, detaching the isolated device from the circuit, and proper disposal to an Owner-approved depot.
- .10 The word **replace** and its derivatives shall be taken to mean to provide new and remove existing devices as required to complete the project.
- .11 The words **work** or **contract** or **project** and their derivatives shall be taken to mean all the work required to plan, permit, manage, execute and sign-off the work as stated in the contract documents.
- .12 The words **feed, feeder, conduit/cable** and their derivatives shall be taken to mean the conduit and cable system complete with all necessary fittings, boxes, seismic attachments, fastenings, grounding and bonding

requirements, roofing penetration requirements, fire ratings, and firestopping approved and rated for continuous use in the electrical system as described in the project.

- .13 The words **Receptacle Cabinet** or **RC** and/or **pedestal** or **kiosk** and their derivatives shall be taken to mean the complete cabinet including its panel, receptacles, luminaire, fixture, and all conduit, wiring, cabling, fasteners, fittings, attachments and labels.

### **1.3 BACKGROUND**

- .1 Fisheries and Oceans Canada, Small Craft Harbours will be upgrading their existing electrical system serving the floats located in Kanaka Harbour.
- .2 The existing 120/208V 200A 3 phase marina electrical distribution system from the existing service entrance on shore to the marina float receptacles shall be replaced by a new 120/208V 200A 3 phase system supply and distribution system.
- .3 The current work is to provide the 3 phase distribution system equipment to replace the existing in-service 3 phase distribution system equipment.
- .4 The existing in-service 3 phase supply and distribution system is to remain in operation until the new distribution system is constructed and ready to be energized.

### **1.4 SUMMARY OF WORK**

- .1 Notwithstanding the scope of work stated within the drawings and all sections of this contract, the contractor is not exempt from and is fully responsible for details omitted or forgotten that contribute to the safe preparation, execution and completion of the Work to a fully functioning, safe, and permanently operational marina electrical system.
- .2 Provision of any temporary power if required by SCH during the project.
- .1 Shutdowns may be required when installing the 3 phase electrical equipment on the floats due to the proximity of the existing 3 phase energized equipment.
- .3 Provide shop drawings of all new equipment to be provided, for review by Engineer 5 working days prior to procurement.
- .4 Install RC's complete with all components and wiring, installed and located as indicated on the drawings and specifications, and as required for a safe and fully functioning RC shore power kiosks.

- .5 Replacement of all float decking removed to install RC's and cables.
- .6 Provide a new MDP and enclosure, installed adjacent to the existing MDP.
- .7 Provide new office panelboard.
- .8 Provide new grounding system.

**1.5 WORK IN PROGRESS**

- .1 Coordination with DFO/SCH operations and other construction work in progress may be required during the execution of this Work.
- .2 Shutdowns shall require the authorization of the Owner and shall be scheduled 5 working days in advance with the Owner. The Owner reserves the right to re-schedule shutdowns at any time due to their operations.

**1.6 WORK COVERED BY CONTRACT DOCUMENTS**

- .1 Work of this Contract includes, but is not limited by:
  - .1 All precautions necessary to ensure that preparation and shutdown work shall be safely executed while other equipment is energized in the vicinity.
  - .2 Provision of all required equipment materials and services for this project as described to properly manage, schedule and coordinate the work in a manner that minimizes the risk of unplanned outages to DFO/SCH and ensures the safety of DFO/SCH personnel, equipment and the public.
  - .3 Provision of a Schedule and Work Plan for the execution of the work in a phased manner such as to minimize the disruption of operations and use by the public and DFO/SCH staff at the site.
  - .4 Provide RC components and install inside Owner Supplied RC enclosures, as required for a safe and fully functioning RC shore power kiosks. The components include the RC panelboards, main and branch breakers, locking receptacles, luminaire, photocell and all internal wiring, connections, fittings, etc.
    - .1 There are four RC enclosures. Each has an RC panel (RCP-1, RCP-2, RCP-3 or RCP-4) with GFCI breakers, locking receptacles and luminaire integral to it, forming RC-1, RC-2, RC-3, RC-4, shore power kiosks.
  - .5 Provision of Seismic Engineering services including Engineered shop drawings showing seismic anchoring and bracing required for MDP

enclosure, mounting, RC's, luminaire bases on Floats and wharfs, and cable trays.

- .6 Provision of approved seismic attachments, fittings and fasteners as described by the Contractor's Seismic Engineer.
- .7 Provision of all distribution feeder junction and/or pull boxes as required.
- .8 Provision of all required testing, commissioning and training services.
- .9 Provision of all shop drawings, O&M manuals and As Built drawings.
- .10 Provision for tool lockups and job site security.
- .2 Work of the Contract comprises the provision of all permits, approvals, written instructions, schedules, plans and submitting of same to the Owner, Engineer, and to the AHJ as required, prior to, during and after the execution of the work.

## **1.7 OWNER SUPPLIED EQUIPMENT**

- .1 Work of this Contract includes, but is not limited by, the following Contractor responsibilities for Owner-supplied equipment. The Owner Supplied equipment is the following enclosures: RC-1, RC-2, RC-3, RC-4.
  - .1 Pick-up and delivery of RC enclosures from designated pick-up depot to final destination for installation at Kanaka SCH.
  - .2 Inspect equipment prior to loading at pick-up site jointly with Owner. Record shortages, damaged or defective items.
  - .3 Handle all products at site, including uncrating and storage. Protect from damage and exposure to elements during the project.
  - .4 Repair or replace items damaged by Contractor or Others during pick-up, delivery, off-loading, storage, or installation on site during project duration.
  - .5 Install all interior and exterior devices to fit in RC's as per this Contract, including all fittings, wiring, connections, fasteners, finishes, adjustments, etc., as required for a safe and continuously energized unit securely fastened to the floats.
  - .6 Submit shop drawings and product data of interior and exterior devices assembled in RC's for approval by Engineer and Owner prior to purchase.
  - .7 Allow inspections as required by Owner, Engineer and AHJ's.

- .2 Owner's responsibilities for Owner supplied RC enclosures:
  - .1 Provide a date and time for pick-up at depot.
  - .2 Ensure staff are available at pick-up site for access, equipment location, damage inspection and site lock-up.
  - .3 Arrange for replacement of damaged, defective or missing items.
  - .4 Delivery of RC enclosure shop drawings, product data, samples, manufacturer's warranties, and certificates to Contractor.

### **1.8 PERSON-IN-CHARGE (PIC)**

- .1 Provide a full-time on-site qualified and experienced Person-in-Charge (PIC) who is an employee of the Contractor and is acceptable to the Owner for the duration of the Project. The PIC shall be tasked with:
  - .1 Overall responsibility for site planning, coordination, and execution of the Project Work, including shutdowns;
  - .2 Site coordination with the Owner, Engineer, Contractors, and others as necessary to complete the Work in an orderly and timely fashion;
  - .3 Provision of shop drawings in a timely manner to the Engineer for approval prior to equipment purchase.
  - .4 Attend all Project Meetings and inspections as required by the Owner and Engineer.
- .2 The Contractor shall:
  - .1 Provide their PIC with support personnel and services as necessary to enable the Project Work to be completed within a reasonable time;
  - .2 Not replace or substitute their PIC with another PIC during the execution of the Work. Should replacement be required under extraneous circumstances, request to do so shall be made in writing and shall be approved by the Owner prior to replacement.

### **1.9 SHUTDOWN WORK**

- .1 For all Shutdown work, the Contractor shall assign a "Person-in-Charge (PIC)" for the shutdown:
  - .1 The PIC shall hold a Safety meeting immediately prior to scheduled Shutdown and obtain signatures of those present.

- .2 The PIC shall be on site at the scene of the work during the entire shutdown and shall be the focal point for communications among the Owner, the Engineer, the Contractor, Subcontractors, BC Hydro, other Contractors on site, and other AHJs.
- .3 The PIC shall explain the work to be executed to all present including other Contractors on site, and ensure all safety procedures are followed by those working on-site including lock & tag-out procedures.
- .4 Only those present and signed-in during the safety meeting shall be allowed in the vicinity of the shutdown work to be executed;
- .5 The signed safety meeting agenda shall be submitted to the Owner and Engineer prior to the shutdown being executed.

#### **1.10 WORK BY OTHERS**

- .1 Cooperate and coordinate Work with that of other Contractors on-site. If any part of work under this Contract depends for its proper execution or result upon work of another Contractor, report promptly to Owner and Engineer in writing, any defects which may interfere with proper execution of Work.
- .2 Work of Project executed prior to start of, or during the Work of this Contract, and which is specifically excluded from this Contract.
  - .1 Provision of BC Hydro secondary cables and connection to the DFO Main Disconnect.

#### **1.11 CONSTRUCTION TIME, SEQUENCE AND PERFORMANCE**

- .1 The Contractor shall provide and maintain in full operation at all times during the Work, a sufficient crew of labourers, trades people, and foremen to execute the Work with dispatch.
- .2 All Work shall be performed by skilled certified trades people, experienced in their trade, according to the rules and customs for best trade practices for first class work and according to the various trade standards.
- .3 During Work maintain fire extinguisher access/control. Notify the Owner of all Work that impacts the access or operation of the existing fire system.
- .4 The Work may be deemed substantially complete when the following are completed, submitted and accepted as such by the Owner and Engineer:
  - .1 All shop drawings and equipment manuals;
  - .2 All deficiency list items completed;

.3 All related documentation.

**1.12 CONTRACTOR USE OF PREMISES**

- .1 Contractor must adhere to security arrangements as required by the Owner.
- .2 Limit use of premises for Work, for storage and for access, to allow
  - .1 Owner occupancy;
  - .2 Work by other contractors;
  - .3 Public usage.
- .3 Construct Work in stages if necessary to provide for continuous public and staff usage. Do not close off public or staff usage of facilities. Coordinate with Owner any work that may interfere with public usage or staff operations.
- .4 Obtain and pay for use of additional storage or work areas off-site if needed for operations under this Contract.
- .5 Remove or alter Work to prevent injury or damage to portions of existing premises which remain.
- .6 Repair or replace portions of existing premises which have been altered during construction to match adjoining Work, as directed by client and engineer.
- .7 At completion of operations the condition of original premises shall be equal to or better than that which existed before Work started.

**1.13 OWNER OCCUPANCY**

- .1 Owner will occupy premises during entire construction period for execution of normal operations.
- .2 Cooperate with Owner in scheduling operations to minimize conflict and to facilitate Owner usage.

**1.14 ALTERATIONS, ADDITIONS OR REPAIRS TO EXISTING BUILDING**

- .1 Execute work with least possible interference or disturbance to Owner's staff, public and normal use of premises. Arrange with Owner and Engineer to facilitate execution of work.

**1.15 EXISTING SERVICES**

- .1 Notify Owner, Engineer and utility companies of intended interruption of services and obtain required permission.
- .2 Where Work involves breaking into or connecting to existing services, provide 5 working days notice to Owner and Engineer for necessary interruption of mechanical or electrical service throughout course of work. Minimize duration of interruptions. Carry out work at times as directed by governing authorities with minimum disturbance to Owner operations.
- .3 Where Work impacts existing entrance and egress routes, provide alternative routes for personnel, pedestrian and vehicular traffic.
- .4 Establish location and extent of service lines in area of work before starting Work. Notify Owner and Engineer of findings.
- .5 Submit schedule to and obtain approval from Owner and Engineer for any shut-down or closure of active service or facility including power and communications services. Adhere to approved schedule and provide notice to affected parties.
- .6 Provide temporary services as directed by Owner and Engineer to maintain critical building and marina systems.
- .7 Provide adequate bridging over trenches which cross sidewalks or roads to permit normal traffic. Provide safety barricades as necessary to prevent public from access to areas under construction.
- .8 Where unknown services are encountered, immediately advise client and engineer and confirm findings in writing.
- .9 Protect, relocate or maintain existing active services. When inactive services are encountered, cap off in manner approved by the AHJ.

**1.16 DOCUMENTS REQUIRED**

- .1 Maintain at job site, one copy each document as follows
  - .1 Contract Drawings
  - .2 Specifications
  - .3 Addenda
  - .4 Reviewed Shop Drawings
  - .5 List of Outstanding Shop Drawings
  - .6 Change Orders



- .7 Field Test Reports
- .8 Copy of Approved Work Schedule
- .9 Health and Safety Plan and Other Safety Related Documents
- .10 Other documents as specified.

**1.17 SITE VISIT**

- .1 Examine the site and the local conditions affecting the Work under this Contract and be satisfied that the Work under this Contract can be carried out as shown on these plans without changes.
- .2 Should the examination, above, of the site and equipment show the requirements for additional work beyond the Work of these Drawings, bring this matter to the attention of the Consultant before Tender Closing.
- .3 No allowance will be made later for any expense incurred by the Contractor through failure to visit the site and make this examination.

**END OF SECTION**

**1 GENERAL**

**1.1 SECTION INCLUDES**

- .1 Health and safety considerations required to ensure that PWGSC shows due diligence towards health and safety on construction sites, and meets the requirements laid out in PWGSC/RPB Departmental Policy DP 073 - Occupational Health and Safety - Construction.

**1.2 REFERENCES**

- .1 Canada Labour Code, Part 2, Canada Occupational Safety and Health Regulations
- .2 Health Canada/Workplace Hazardous Materials Information System (WHMIS)
  - .1 Material Safety Data Sheets (MSDS).
- .3 Province of British Columbia
  - .1 Workers Compensation Act, RSBC 1996 - Updated 2006.
  - .2 Occupational Health and Safety Act, S.N.S. [1996].

**1.3 SUBMITTALS**

- .1 Make submittals in accordance with Section 01 00 10 – General Requirements.
- .2 Submit site-specific Health and Safety Plan: Within 7 days after date of Notice to Proceed and prior to commencement of Work. Health and Safety Plan must include:
  - .1 Results of site specific safety hazard assessment.
  - .2 Results of safety and health risk or hazard analysis for site tasks and operation found in work plan.
  - .3 Risk Management and Safety Procedure for possible events including but not limited to storm, fire, and fall.
- .3 Submit one copy of Contractor's authorized representative's work site health and safety inspection reports to Departmental Representative weekly.
- .4 Submit copies of reports or directions issued by Federal, Provincial and Territorial health and safety inspectors.
- .5 Submit copies of incident and accident reports.

- .6 Submit WHMIS MSDS - Material Safety Data Sheets if requested.
- .7 Departmental Representative may review Contractor's site-specific Health and Safety Plan and provide comments to Contractor within 5 days after receipt of plan. Revise plan as appropriate and resubmit plan to Departmental Representative within 5 days after receipt of comments from Departmental Representative.
- .8 Departmental Representative's review of Contractor's final Health and Safety plan should not be construed as approval and does not reduce the Contractor's overall responsibility for construction Health and Safety.
- .9 Medical Surveillance: where prescribed by legislation, regulation or safety program, submit certification of medical surveillance for site personnel prior to commencement of Work, and submit additional certifications for any new site personnel to Departmental Representative.
- .10 On-site Contingency and Emergency Response Plan: address standard operating procedures to be implemented during emergency situations.

#### **1.4 FILING OF NOTICE**

- .1 File Notice of Project with Provincial authorities prior to beginning of Work.

#### **1.5 SAFETY ASSESSMENT**

- .1 Perform site specific safety hazard assessment related to project.

#### **1.6 MEETINGS**

- .1 Schedule and administer Health and Safety meeting prior to commencement of Work.

#### **1.7 PROJECT/SITE CONDITIONS**

- .1 Work at site will involve contact with:
  - .1 Harbour Manager.
  - .2 Departmental Representative.

#### **1.8 GENERAL REQUIREMENTS**

- .1 Develop written site-specific Health and Safety Plan based on hazard assessment prior to beginning site Work and continue to implement, maintain,

and enforce plan until final demobilization from site. Health and Safety Plan must address project specifications.

- .2 Departmental Representative may respond in writing, where deficiencies or concerns are noted and may request re-submission with correction of deficiencies or concerns.

## **1.9 RESPONSIBILITY**

- .1 Be responsible for health and safety of persons on site, safety of property on site and for protection of persons adjacent to site and environment to extent that they may be affected by conduct of Work.
- .2 Comply with and enforce compliance by employees with safety requirements of Contract Documents, applicable federal, provincial, territorial and local statutes, regulations, and ordinances, and with site-specific Health and Safety Plan.

## **1.10 COMPLIANCE REQUIREMENTS**

- .1 Comply with Workers Compensation Act, B.C.
- .2 Comply with Occupational Health and Safety Regulations.
- .3 Comply with Canada Labour Code, Canada Occupational Safety and Health Regulations.

## **1.11 UNFORSEEN HAZARDS**

- .1 When unforeseen or peculiar safety-related factor, hazard, or condition occur during performance of Work, follow procedures in place for Employee's Right to Refuse Work in accordance with Acts and Regulations of Province having jurisdiction and advise Departmental Representative verbally and in writing.

## **1.12 HEALTH AND SAFETY CO-ORDINATOR**

- .1 Employ and assign to Work, competent and authorized representative as Health and Safety Co-ordinator. Health and Safety Co-ordinator must:
  - .1 Have site-related working experience specific to activities associated with dredging and material transportation.
  - .2 Have working knowledge of occupational safety and health regulations.
  - .3 Be responsible for completing Contractor's Health and Safety Training Sessions and ensuring that personnel not successfully completing required training are not permitted to enter site to perform Work.

- .4 Be responsible for implementing, enforcing daily and monitoring site-specific Contractor's Health and Safety Plan.
- .5 Be on site during execution of Work.

**1.13 POSTING OF DOCUMENTS**

- .1 Ensure applicable items, articles, notices and orders are posted in conspicuous location on site in accordance with Acts and Regulations of Province having jurisdiction, and in consultation with Departmental Representative.

**1.14 CORRECTION OF NON-COMPLIANCE**

- .1 Immediately address health and safety non-compliance issues identified by authority having jurisdiction or by Departmental Representative.
- .2 Provide Departmental Representative with written report of action taken to correct non-compliance of health and safety issues identified.
- .3 Departmental Representative may stop Work if non-compliance of health and safety regulations is not corrected.

**1.15 WORK STOPPAGE**

- .1 Give precedence to safety and health of public and site personnel and protection of environment over cost and schedule considerations for Work.

**END OF SECTION**

**1 GENERAL**

**1.1 SUMMARY**

.1 Documents

.1 This Division 26 Section, together with all other Sections forms part of the Contract Documents and is to be read, interpreted, and coordinated with all other parts and Divisions.

.2 This Section Includes:

.1 Abbreviations

.2 Brief Summary of Work

.3 Phasing

.4 Codes, Standards, and Regulatory Requirements

.5 Permits, Fees, and Inspection

.6 Quality of Work

.7 Qualification of Tradesmen

.8 Responsibility and Coordination

.9 Protection

.10 Drawings and Measurements

.11 Materials and Equipment

.12 Identification

.13 Approvals

.14 Testing and Adjusting

.15 Cleaning and Repair

.16 Guarantee

.17 Project Documentation: Shop Drawings, Maintenance Manuals, "As-Built" Drawings

- .18 Loose Equipment
- .19 Substantial Performance Inspection
- .20 Measurement and Payment
- .21 Evaluation of Changes to the Contract

## **1.2 ABBREVIATIONS**

- .1 The following project-specific equipment abbreviations have been used in these specifications:
  - .1 RC: New Receptacle Cabinet with receptacle panel, receptacles, and top light fixture.
  - .2 SCH: Fisheries and Oceans Canada, Small Craft Harbours, the Project Owner.
- .2 Other abbreviations to CSA Z85.

## **1.3 BRIEF SUMMARY OF WORK**

- .1 Refer to Section 01 00 11 Summary of Work.
- .2 The work includes but is not limited to:
  - .1 Arrangements, pick-up, delivery, and installation of Owner supplied RC's at the SCH depot.
  - .2 The provision of shop drawings to Engineer for approval prior to the purchase of electrical equipment to be installed.
  - .3 The provision and assembly of all components required for safe and continuous operation of RC's.
  - .4 All planning, organizing, scheduling, managing and coordinating as required with BC Hydro, SCH Harbour Manager, SCH Project Manager and the Engineer.
  - .5 Completion of the deficiency list as compiled by SCH Project Manager and Engineer.

## **1.4 PHASING**

- .1 Phase the work to minimize service outages.
- .2 Outages shall not exceed 24 hours. Schedule the work to reduce outage duration to less than 24 hours wherever possible.
- .3 Prepare a detailed schedule of proposed shutdown of existing power services giving date, time, duration of each shutdown and the services affected and submit to the Engineer and Owner for comment and necessary changes. Provide 2 weeks' notice of proposed shutdown.
- .4 The Owner reserves the right to insist upon changes to the schedule of shutdowns without penalty or cost.
- .5 Erect barricades and provide temporary signage and lighting as necessary to protect the public during construction activities. Do not leave tripping hazards or loose planks while wharf is unattended.

## **1.5 CODES, STANDARDS, AND REGULATORY REQUIREMENTS**

- .1 Any reference to Codes, Standards, and Regulations in these Specifications shall be taken as the latest or the most current in effect at time of tender.
- .2 Comply with all requirements of the Canadian Electrical Code - Part I, including all Provincial and other amendments, Electrical Bulletins, and any local by-laws or rules regulating the installation of electrical equipment. In no instance, however, shall the standards established by the Contract Documents be reduced by any of these Codes or Regulations.
- .3 All materials shall bear the approval of the Canadian Standards Association and where applicable, the Underwriters' Laboratories of Canada or alternately shall bear local approval from the Electrical Inspection Department having jurisdiction. Include in the Tender all costs associated with obtaining local approvals.
- .4 Operating voltages to CAN3-C235.

## **1.6 PERMITS, FEES, AND INSPECTION**

- .1 Before starting work submit the appropriate quantity of Drawings and Specifications to the Electrical Inspection Department and other authorities having jurisdiction and obtain all necessary approvals and permits. Include all costs of approvals and all permit fees in the tender.



- .2 Engineer will provide Drawings and Specifications required by the Contractor for submission to the Electrical Inspection Department, the Supply Authority, and other authorities having jurisdiction, at no cost.
- .3 Arrange for inspection of the work as the installation progresses and as further required (as well as attendance during verification) by all applicable authorities having jurisdiction.
- .4 Notify Engineer of changes required by Electrical Inspection Department prior to making changes.
- .5 Upon completion, and before final payment will be made, present to the Engineer a certificate of unconditional approval for all electrical work from the Electrical Inspection Department and other authorities having jurisdiction.

## **1.7 QUALITY OF WORK**

- .1 Unless otherwise indicated, all materials supplied shall be new and of the quality indicated in these Specifications. Otherwise, they shall be of the best commercial quality obtainable for the purpose.
- .2 Manufacturers' directions shall be followed in all cases where the manufacturers of equipment or materials used in this work furnish directions covering points not shown on the Drawings or Specifications.
- .3 Unless otherwise directed, all installed materials or equipment exposed to view shall be plumb, true, square, and/or level as the case directs and, where applicable, located symmetrically.

## **1.8 QUALIFICATION OF TRADESMEN**

- .1 The work shall be performed by qualified and certified tradesmen as set out in the Electrical Safety Regulation within the Electrical Safety Act.
- .2 Submit list showing names and qualifications of key supervisory personnel.

## **1.9 RESPONSIBILITY AND COORDINATION**

- .1 Supply all labour, materials, equipment, tools, and incidentals necessary to provide a complete electrical installation as indicated on the Drawings and as set out in these Specifications.

- .2 The Drawings and Specifications complement each other and what is called for by one is binding as if called for by both. If there is any doubt as to the meaning or true intent due to a discrepancy between the Drawings and Specifications, obtain a ruling from the Engineer prior to tender closing. Failing this, the most expensive alternative is to be allowed for.
- .3 Advise the Engineer of any specified equipment, material, or installation of same which appears inadequate or unsuitable or which is in violation of laws, ordinances, rules, or regulations of authorities having jurisdiction. Provide all labour and materials which are obviously necessary or reasonably implied to be necessary to complete the work as if the work was shown on the Drawings and/or described in the Specifications.

#### **1.10 PROTECTION**

- .1 Protect exposed live equipment during construction for personnel safety.
- .2 Shield and mark live parts "LIVE 120 VOLTS," or with appropriate voltage.
- .3 Arrange for installation of temporary covers for enclosures containing electrical distribution equipment. Keep these covers locked except when under direct supervision of electrician.

#### **1.11 DRAWINGS AND MEASUREMENTS**

- .1 Drawings are generally diagrammatic and are intended to indicate the scope and general arrangement of work. Do not scale the Drawings.
- .2 The Drawings show approximate locations of outlets, equipment, and apparatus but the right is reserved to make such changes in location before installation of the work as may be necessary to meet the exigencies of construction in any way. No extra will be allowed and conversely, no credit shall be expected for such changes unless for each item of work the distance moved exceeds 3 m prior to final installation of same.
- .3 Take field measurements where equipment and material dimensions are dependent upon structure dimensions.

#### **1.12 MATERIALS AND EQUIPMENT**

- .1 Equipment and material to be new and CSA-certified. Where there is no alternative to supplying equipment which is not CSA-certified, obtain special approval from Electrical Inspection Department.
- .2 Factory assemble control panels and component assemblies.

### **1.13 IDENTIFICATION**

- .1 Identify all pieces of electrical equipment other than conduits and conductors with engraved nameplates, having black characters on white or light background, mechanically attached.
- .2 Nameplate wording shall be such as to indicate clearly the function of each piece of equipment so identified. Prior to manufacture of nameplates, obtain approval from the Engineer for wording intended.
- .3 Provide laminated plastic nameplates at indoor locations and inside equipment cabinets that normally remain closed.
- .4 Provide 316L polished lamcoid nameplates for all outdoor equipment, minimum 12 mm high engraved text with black baked-on enamel filling and white background. Four threaded studs welded at the back for mechanical attachment to outdoor equipment. Apply Secaflex or equal sealant on rear of nameplate to seal stud holes.

### **1.14 APPROVALS**

- .1 Requests for approval of the substitution of materials pertaining to electrical work prior to awarding of any contract must be submitted to the Contracting Officer at least 10 days before the close of tender as per General Instructions - Construction Services ( 2015-02-25), GI13 (2015-02-25) Approval of Alternative Materials. (<https://buyandsell.gc.ca/policy-and-guidelines/standard-acquisition-clauses-and-conditions-manual/5/R/R2410T/14>). The request will be subject to the review and approval by the Engineer.
- .2 All submissions shall include the following information:
  - .1 Name and identification of specified item.
  - .2 Manufacturer, brand name, and catalogue number of the alternative item proposed.

- .3 Detailed technical data and characteristics of alternative item such as dimensions, voltage, power requirements, performance characteristics, etc.
- .4 A list of any and all changes to the installation which may be required as a result of the substitution.
- .3 Review by the Engineer of alternate materials as permitted above is only a general approval in principal and shall not relieve the Contractor of his responsibility to ensure that any approved alternate materials perform in the same manner and with the same intent as the originally specified material would have otherwise performed.
- .4 Where such substitutions alter the design or space requirements indicated on the Drawings, include all material, labour, design, and engineering costs for the revised design and construction including costs of all other trades affected and those incurred by the Engineer.
- .5 It is the Contractor's responsibility to ensure substituted products are approved and that suppliers have written approval indicating conditions of any such approval. Alternate manufacturers who do not have such approval shall not be used in the work. If requested by the Engineer, the Contractor for Division 26 shall submit for inspection, samples of both the specified and the proposed substitute items on short notice.

#### **1.15 TESTING AND ADJUSTING**

- .1 Coordinate and pay for all tests specified herein including further tests as required by authorities having jurisdiction.
- .2 All testing shall be performed after each system installation has been completed and prior to the system being put into continuous operation unless otherwise noted.
- .3 Perform the testing, adjusting, and balancing only when conditions are commensurate with actual operating conditions for the given system.
- .4 Advise the Engineer 48 hours in advance of each test. Carry out tests in the presence of Engineer.
- .5 The Electrical Contractor shall use his own forces for the following tests:
  - .1 Test phase relationships and polarity at all equipment and outlets and devices.

- .2 Test all circuits originating from branch distribution panels.
- .3 Provide ground resistance tests for all circuits.
- .6 Submit typed test reports to the Engineer. Include individual insulation resistance results for each feeder utilizing Type G-GC or Teck cable.

**1.16 CLEANING AND REPAIR**

- .1 At the conclusion of the job and before the project will be accepted by the Owner, all panelboards and other electrical equipment shall be clean and free of dust, plaster, paint, and other foreign materials.
- .2 Repair, at no cost to the Owner, any equipment or structures damaged by the execution of Contract to its original condition.
- .3 Replace, at no cost to the Owner, any equipment or structures damaged by the execution of Contract which is irreparable.
- .4 Openings and cut-outs shall not be burned into panels. Oversized openings shall not be patched up with loose plates or oversized washers. Oversized openings shall be considered damage to the equipment and shall be treated as specified.

**1.17 GUARANTEE**

- .1 Use of installed equipment during construction shall not shorten or alter the guarantee.
- .2 Unless otherwise noted, the warranty period for all equipment shall commence on the date of Substantial Performance for the entire Construction Contract.
- .3 Within a period of one year from the date of final acceptance of work, replace or repair at own expense any defect in workmanship or material.

**1.18 PROJECT DOCUMENTATION**

- .1 Shop Drawings
  - .1 Submit one electronic plus three (3) prints of all shop and setting drawings or diagrams to the Engineer 10 working days in advance of requirements to allow time for review and comment. One print will be forwarded to the Owner, one will be retained by the Engineer for their

office use, one copy will be marked and returned to the Contractor for correction if necessary, further reproduction, and distribution as required.

- .2 Shop drawings shall be neatly drafted and shall be complete and detailed. This requirement is mandatory for such items as panelboards and custom-fabricated equipment panels, consoles, or enclosures.
- .3 Shop drawings shall:
  - .1 Be numbered in consecutive order;
  - .2 Indicate the specific name of the equipment and where it is to be installed;
  - .3 the name of the site/project where installation will occur;
  - .4 the name of the manufacturer, make, model, ratings;
  - .5 date of the drawing including notation of latest revision, if any;
  - .6 Indicate details of construction, dimensions, locations of cable terminations, capacities, weights and electrical performance characteristics of equipment and materials.
- .4 Shop drawings shall be reviewed by the Contractor prior to submission to the Engineer. **Shop drawings not bearing Contractor's approval stamp, approval date, signature**, and project name will be returned without comment.
- .5 Review of shop drawings by the Engineer is for the sole purpose of ascertaining conformance with the general design intent. The review shall not mean approval of the detail design inherent in the shop drawings, responsibility for which shall remain with the Contractor submitting same, and such review shall not relieve the Contractor of his responsibility for errors or omissions in the shop drawings or of his responsibility for meeting all requirements of the Contract Documents.
- .6 The Contractor is responsible for dimensions to be confirmed and correlated at the job site, for information that pertains solely to fabrication processes or to techniques of construction and installation and for coordination of the work of all sub-trades.

.2 Maintenance Manuals

- .1 Furnish to the Engineer three (2) complete bound sets of typewritten or blueprinted instructions for operating and maintaining all systems and equipment included in this Contract.
  - .2 Submit all instructions first in draft for approval prior to final issue.
  - .3 Manufacturers' advertising literature or catalogues will not be accepted for operating and maintenance instructions.
  - .4 Manufacturers' parts list shall be included in each Maintenance Manual.
  - .5 Each set shall consist of a 3-ring binder and a flyleaf with the name of the General Contractor, Electrical Subcontractor, and major equipment suppliers, or their local representatives if they are not local manufacturers, together with addresses and telephone numbers of all parties.
  - .6 Each system or piece of equipment shall have its own section separated from the next by a labelled divider. Shop drawings shall be included in the appropriate section. They shall be fastened into the book by means of a tab which will allow the drawings to be unfolded without being removed from the book.
  - .7 Include copies of all applicable guarantees, warranties, inspection approval certificates, and test certificates.
- .3 "As-Built" Drawings
- .1 Refer to Division 1 of these Specifications.
  - .2 Maintain in the job site office in up-to-date condition, one (1) complete set of whiteprints of each of the Electrical Contract Drawings and one (1) set of Specifications, including Revision Drawings, marked clearly and indelibly in red, indicating "As-Built" conditions where such conditions deviate from the original directions of the Contract Documents, and indicating final installation of feeders and branch circuits.
  - .3 "As-Built" drawing markings shall include but shall not be limited to the following:
    - .1 All changes in circuiting
    - .2 Size and routing of all conduits for all branch circuits including power, lighting, and systems. Accurately record on "As-Built" drawings the size and routing of all installed raceways and cables.

- .3 Number and size of conductors in raceways and cables
  - .4 Location of all junction and pull boxes
  - .5 All changes to electrical installation resulting from Addenda, Change Orders, and Field Instructions
  - .6 Exact location of all services left for future work
  - .7 Location by accurate horizontal and vertical dimensions of the routes and terminations of all raceways and cables installed underground. **"As-built" mark-ups for area below the Main Distribution Panel (MDP) shall include data on existing and new installation showing location and size of ducts, and number and size of conductors therein.**
- .4 Each "As-Built" drawing as defined above shall bear the Contractor's identification and signature, the date of record, and the notation: *"We hereby certify that these Drawings represent the condition as built."*
  - .5 Deliver "As-Built" mark-up drawings to the Engineer at 'Substantial Completion' of the Contract for review and comment and, if necessary, revision. A holdback will be effected by the Engineer until "As-Built" drawing mark-ups are delivered in good order as required herein.

#### **1.19 LOOSE EQUIPMENT**

- .1 All loose and portable components and equipment to be provided shall be handed over to the Owner at Substantial Performance of the Contract and receipts obtained.
- .2 Copies of such receipts shall be given to the Engineer, with a copy included in Maintenance Manual.

#### **1.20 SUBSTANTIAL PERFORMANCE INSPECTION**

- .1 Before the Engineer is requested to make a Substantial Performance inspection, submit written confirmation that:
  - .1 All equipment is operational, plumb, clean, and correctly labelled
  - .2 All Test Reports have been submitted
  - .3 All certificates of final acceptance from the authorities having jurisdiction have been received and submitted to the Engineer



- .4 Equipment has been cleaned, touched up, or refinished as necessary to present a new appearance
- .5 All loose equipment including spare parts and replacement parts have been turned over to the Owner and receipts obtained for same
- .6 The Maintenance Manual has been submitted
- .7 The "As-Built" drawing mark-ups have been submitted to the Engineer
- .2 Notwithstanding any other provisions of the Contract, failure to complete all of the above shall give cause to deny the issuance of a Substantial Performance Certificate.

#### **1.21 MEASUREMENT AND PAYMENT**

- .1 Notwithstanding any other provisions of this Contract, supply the following general information and any additional information as may be requested by the Engineer, as part of each Monthly Progress Claim. Indicate the labour cost and the material cost separately for each **Item of Work**.
- .2 **Items of Work** includes the supply and installation of, and shall not necessarily be limited to the following:
  - .1 New panelboard for Harbour Manager's office including re-connections to new office panel.
  - .2 MDP enclosure and interior components.
  - .3 RC enclosures and interior components.
  - .4 Documentation including shop drawings, maintenance manuals and final mark-ups for "As-Built" drawings
  - .5 Mobilization and demobilization including clean-up
- .3 Progress claims will not be certified nor payment made beyond 95% before holdback is applied for each item of work as previously defined or on the overall contract until commissioning and verification of the systems have been completed. This procedure is to allow for any necessary deficiency holdbacks on items which do not become apparent until the systems have been fully commissioned and are operational.
- .4 Format for Monthly Progress Draws shall be similar to the sample shown at the end of this section.

- .5 For each Monthly Progress Draw, change orders shall be listed separately.

**1.22 EVALUATION OF CHANGES TO THE CONTRACT**

- .1 Notwithstanding other provisions of the Contract, this Contractor shall supply detailed information for the valuation of all changes to the Contract. Such information shall include, but not necessarily be limited to, the following:
- .1 Labour hours per unit of material or equipment to be added, deleted, or altered.
  - .2 Units of material or equipment to be added or deleted.
  - .3 Cost to the Contractor per unit of material, equipment, and labour broken down by category of labour and type of material or equipment.
  - .4 Extensions of the above to arrive at total costs.
  - .5 Other miscellaneous and identifiable charges as allowed in the General Conditions.
- .2 Include in the valuation of any change to the Contract the cost, if any, of recording such change on the "As-Built" drawings as previously specified.

**2 PRODUCTS**

- .1 Not used

**3 EXECUTION**

- .1 Not used

**END OF SECTION**

Draw No.	For the Month of:	19		Project:		Prepared by	
		Contract	To Date	Previous Claim	This Claim	Notes	
Item	Labour \$	Material \$	Labour \$	Material \$	Labour \$	Material \$	
These items are to be as generally listed in the Specification and as specifically agreed with the Consultant.							
<b>Sample</b>							
T total							
T total Labour/Material							
	Less 10% Lien Holdback						
	Total Claim This Month						

Provide the following information with each progress draw:

- A. Material on hand (not installed) previous claim \$ \_\_\_\_\_
- B. Material from "A" installed this claim \$ \_\_\_\_\_
- C. Material from "A" not installed this claim (A-B) \$ \_\_\_\_\_
- D. Material on hand (not installed) added since last claim \$ \_\_\_\_\_
- E. Total material on hand (not installed) this claim (C+D) \$ \_\_\_\_\_

**1 GENERAL**

**1.1 SECTION INCLUDES**

- .1 Teck armoured cable, RW90 XLP, G/GC portable power cable.
- .2 Wire connectors
- .3 Box connectors for cable

**1.2 RELATED WORK**

- .1 Section 26 05 01 - Electrical General Requirements

**1.3 REFERENCES**

- .1 Wires and Cables
  - .1 CSA C22.2 No. 0.3, Test Methods for Electrical Wires and Cables
  - .2 CSA C22.2 No. 65, Wire Connectors
  - .3 CAN/CSA C22.2 No. 131, Type Teck 90 Cable
- .2 Wire and Box Connectors
  - .1 CAN/CSA-C22.2 No. 18, Outlet Boxes, Conduit Boxes, Fittings and Associated Hardware
  - .2 CSA C22.2 No. 65, Wire Connectors

**2 PRODUCTS**

**2.1 WIRE AND CABLE - GENERAL**

- .1 Unless otherwise directed, wire and cable shall be copper conductors, sized as indicated.
- .2 Except where otherwise directed or required by The Canadian Electrical Code or other applicable regulations, wire and cable insulation shall be Type RW90, cross-linked polyethylene insulated for 600 V and rated not less than 90°C.
- .3 All conductors #8 AWG and larger shall be stranded, Type RW90, cross-linked polyethylene insulated for 1000 V and rated not less than 90°C.

**2.2 TECK CABLE**

- .1 Conductors
  - .1 Grounding conductor: copper
  - .2 Circuit conductors: copper, size as indicated.
- .2 Insulation: chemically cross-linked thermosetting polyethylene, rated type RW90, 600 V.
- .3 Inner jacket: polyvinyl chloride material.
- .4 Armour: interlocking aluminum.
- .5 Overall covering: polyvinyl chloride material.
- .6 Connectors: watertight, approved for Teck cable installation.

**2.3 PORTABLE POWER CABLE**

- .1 Approved for wet locations, for extra hard usage, 90°C, 2000 V insulation, ultraviolet-resistant black jacket.
- .2 Type G or Type G-GC, multi-conductor, with separate insulated ground check conductor and separate ground conductors.
- .3 Type W, single-conductor with separate polyester braid reinforcement between the insulation and jacket.

**2.4 WIRE AND BOX CONNECTORS AND MISCELLANEOUS MATERIALS**

- .1 Connectors for wire and cable splices and taps: Unless otherwise directed, use 3M Co. 'Scotchlok,' Thomas & Betts PT Series, Buchanan 'B,' IDI Electric 'Super Nut,' or approved equal, for conductors #8 AWG or smaller; Burndy 'Servit' Type KSU or approved equal for conductors #1/0 AWG and smaller; and Burndy 'OKlip' Type KVSU or approved equal for conductors 750 MCM or smaller.
- .2 Clamps, glanding connectors, or box connectors for armoured cable as required.
- .3 Lugs, terminals, screws used for termination of wiring to be suitable for either copper or aluminum conductors.
- .4 Copper, short barrel crimp-on compression type connectors as required, sized for conductors.

**2.4 WIRE AND BOX CONNECTORS AND MISCELLANEOUS MATERIALS (cont.)**

- .5 Plastic electrical insulation tape: Scotch #88 or approved equal.
- .6 Kellums grips: double-eye, double-weave, stainless steel.

**3 EXECUTION**

**3.1 INSTALLATION - GENERAL**

- .1 Unless noted otherwise, perform all installation and provide new materials to match existing.

**3.2 INSTALLATION OF WIRES AND CABLES - GENERAL**

- .1 Unless specifically indicated otherwise, all wiring to MDP and to RCs on floats shall be Type G or Type G-GC.
- .2 All wire from MDP or from RC to luminaires on float light standards to be Teck 90 600V cable.
- .3 Use no wire smaller than #12 AWG, unless otherwise directed.
- .4 No splices, other than those shown, will be permitted. All splices must be made in junction boxes above water level.
- .5 Between float sections provide a 0.9 meter minimum loop as shown on drawings.
- .6 Coil extra 1.5 meters of cable (mounted at low tide) on landing at bottom of gangway as shown on drawings.
- .7 All cables and cords shall be adequately supported to avoid strain on connections. Where cords and cables are suspended vertically, use stainless steel cable grips (Kellums or equal).

**3.3 INSTALLATION OF WIRE AND BOX CONNECTORS**

- .1 Remove insulation carefully from ends of conductors and:
  - .1 Install mechanical pressure-type connectors and tighten screws with appropriate compression tool recommended by manufacturer. Installation shall meet secureness tests in accordance with CSA C22.2 No. 65.
  - .2 Install fixture type connectors and tighten. Replace insulating cap.
- .2 Wire and cable splices and taps shall be made with approved connectors used in accordance with the manufacturer's instructions.

- .3 Wrap connectors having exposed conductive surfaces after installation, with self-fusing rubber electrical tape, applying enough servings to provide uniform covering not thinner than the insulation of the largest conductor connected and overlapping the insulation of each connected conductor by not less than 12 mm. Protect the rubber tape with a final overwrap of plastic tape.

END OF SECTION

**PART 1 GENERAL**

**1.1 RELATED WORK**

- .1 This Section of the Specification forms part of the Contract Documents and is to be read, interpreted and coordinated with all other parts.

**1.2 REFERENCE STANDARDS**

- .1 American National Standards Institute (ANSI)/Institute of Electrical and Electronics Engineers (IEEE)
- .2 All grounding conductors to be stranded soft annealed copper unless otherwise noted.
- .3 Install complete grounding and bonding system in accordance with Canadian Electrical Code and local inspection authority requirements.

**1.3 TESTING REQUIREMENTS**

- .1 Perform ground continuity and resistance tests using method appropriate to site conditions. Measure ground grid resistance.
- .2 Any third party testing agency costs for the testing and reporting shall be included in the Electrical Division base tender and shall be carried out by a pre-approved testing agency.

**PART 2 PRODUCTS**

**2.1 MATERIALS**

- .1 Grounding equipment to: CSA C22.2 No.41.

**2.2 EQUIPMENT**

- .1 Clamps for grounding of conductor, size as required.
- .1 Rod electrodes, copper clad steel 20mm [3/4"] dia by 3m [10'] long or as indicated.
- .2 System and circuit, equipment, grounding conductors, bare stranded copper, soft annealed, sized as indicated. Insulation where specified or required to be green.
- .3 Ground bus: copper, size as indicated, complete with insulated supports, fastenings, connectors.



- .4 Non-corroding accessories necessary for grounding system, type, size material as indicated, including but not necessarily limited to:
  - .1 Grounding and bonding bushings.
  - .2 Protective type clamps.
  - .3 Bolted type conductor connectors.
  - .4 Thermit welded type conductor connectors.
  - .5 Bonding jumpers, straps.
  - .6 Pressure wire connectors.

### **PART 3 EXECUTION**

#### **3.1 INSTALLATION - GENERAL**

- .1 Install complete permanent, continuous bonding to ground system, including conductors, connectors, and accessories. Run bonding wire in every conduit.
- .2 Provide all grounding and bonding to conform with the latest edition of the Canadian Electrical Code and the latest grounding and bonding instructions of the Inspection Authority, with any further requirements as noted herein or on the drawings.
- .3 Bonding to ground and grounding conductors shall be as specified elsewhere and shall be bare copper or have green insulation with identification at all ends.
- .4 Neutral to ground conductors shall be copper conductor of size indicated with white insulation.
- .5 Install connectors in accordance with manufacturer's instructions.
- .6 Protect exposed grounding conductors from mechanical injury.
- .7 Use cable lugs for bonding non-current carrying metallic parts of electrical equipment to ground.
- .8 connections to switchboards, ground buses, and other equipment.
- .9 Soldered joints are not permitted.

#### **3.2 GROUNDING BUSSES**

- .1 Provide a ground bus in the main electrical room. Ground bus shall consist of suitable length of 50mm x 6mm [2"x ¼"] copper bus mounted on a 25mm [1"]

insulating standoffs. This bus shall be drilled and tapped to receive all the grounding conductors indicated and an engraved nameplate or tag installed above or below individual conductors indicating their function.

- .2 Ground items of electrical equipment in electrical room to ground bus with individual bare stranded copper connections size 3/0 AWG or as indicated.
- .3 Copper or bronze lugs required for termination of all copper conductors at ground busses.

### **3.3 POST MOUNTED LUMINAIRE BONDING**

- .1 Provide #10 AWG bonding conductor with green RW90 X-link insulation to luminaire standards. Connect to luminaire corrosion resistant ground stud or ground clamp.

### **3.4 FIELD QUALITY CONTROL**

- .1 Perform tests in accordance with Section 26 05 01.
- .2 Perform ground continuity and resistance tests using method appropriate to site conditions.
- .3 Measure ground grid resistance with earth test megohmmeter and install additional ground rods and conductors as required until resistance to ground complies with Code requirements and is less than 1 $\Omega$ .
- .4 Carry out all tests required by the Electrical Inspection Authority and provide all required reports and copied to the Consultant. Include all associated costs.
- .5 Ensure test results are satisfactory before energizing the electrical system.

END OF SECTION

**1 General**

**2 Products**

**2.1 SUPPORT CHANNELS**

- .1 U shape, size 41 x 41 mm, 2.5 mm thick, surface-mounted.

**3 Execution**

**3.1 INSTALLATION**

- .1 Support equipment, conduit or cables using clips, spring loaded bolts, cable clamps designed as accessories to basic channel members.
- .2 Fasten exposed conduit or cables to boardwalk, approach and wharf construction or support system using straps.
  - .1 One-hole steel straps to secure surface conduits and cables 50 mm and smaller.
  - .2 Two-hole steel straps for conduits and cables larger than 50 mm.
  - .3 Beam clamps to secure conduit to exposed steel work.
- .3 Suspended support systems.
  - .1 Support individual cable or conduit runs with 6 mm diameter threaded rods and spring clips.
  - .2 Support 2 or more cables or conduits on channels supported by 6 mm diameter threaded rod hangers where direct fastening to building construction is impractical.
  - .3 Support cables in galvanized cable tray where indicated.
- .4 For surface mounting of two or more conduits use channels at 1 m oc spacing.
- .5 Provide metal brackets, frames, hangers, clamps, cable tray and related types of support structures where indicated or as required to support conduit and cable runs.
- .6 Ensure adequate support for raceways and cables dropped vertically to equipment.
- .7 Do not use wire lashing or perforated strap to support or secure raceways or cables.
- .8 Do not use supports or equipment installed for other trades for conduit or cable support except with permission of other trade and approval of Consultant.

- .9 Install fastenings and supports as required for each type of equipment cables and conduits, and in accordance with manufacturer's installation recommendations.

END OF SECTION

**1 GENERAL**

**1.1 SECTION INCLUDES**

- .1 Conduits, conduit fastenings, and conduit fittings

**1.2 REFERENCES**

- .1 CAN/CSA C22.2 No. 18, Outlet Boxes, Conduit Boxes, and Fittings and Associated Hardware
- .2 CSA C22.2 No. 56, Flexible Metal Conduit and Liquid-Tight Flexible Metal Conduit
- .3 CSA C22.2 No. 211.2, Rigid PVC (Unplasticized) Conduit

**1.3 LOCATION OF CONDUIT**

- .1 Drawings do not indicate all conduit runs. Those indicated are in diagrammatic form only.

**2 PRODUCTS**

**2.1 CONDUITS**

- .1 Rigid PVC conduit: to CSA C22.2 No. 211.2
- .2 Rigid galvanized steel threaded conduit (RGS) to ANSI C80.1.
- .3 Flexible metal conduit: to CSA C22.2 No. 56, aluminium or zinc-coated steel, liquid-tight. "Spec-Flex" or equivalent.

**2.2 CONDUIT FITTINGS**

- .1 Fittings: manufactured for use with conduit specified.
- .2 Factory "ells" where 90° bends are required for 25 mm and larger conduits.
- .3 Liquid-tight fittings for liquid-tight flexible conduit: equivalent to T&B 'Super-Tite' 5000 Series. All connectors shall have insulated throats.
- .4 Nylon-Insulated Conduit Bushings: T&B or equal.

**2.3 CONDUIT BOXES**

- .1 Cast FS or FD aluminum boxes with factory-threaded hubs and external mounting feet for surface wiring.

**2.4 PULL CORD**

- .1 For 25 mm or larger trade size conduit: 6 mm diameter nylon or polypropylene cord or other approved product.

**3 EXECUTION**

**3.1 INSTALLATION - GENERAL**

- .1 Generally, and where permitted by the Canadian Electrical Code, use rigid PVC conduit for all wiring unless otherwise noted.
- .2 Do not install PVC where it may be subject to mechanical injury.
- .3 For any one conduit section, use the maximum possible conduit length. Installations which use partial lengths and/or excessive number of couplings shall not be acceptable and shall be replaced at Contractor's expense.
- .4 Install exposed conduits in close parallel groups wherever two or more conduits running in the same direction would otherwise be within 1800 mm of each other.
- .5 Install all conduits parallel or at right angles to structure lines, as the case directs.
- .6 Do not install conduit through structural members unless specific instructions are given.
- .7 Install a pull cord in all empty conduits.

END OF SECTION

**PART 1 GENERAL**

**1.1 RELATED WORK**

- .1 This Section of the Specification forms part of the Contract Documents and is to be read, interpreted and coordinated with all other parts.

**1.2 REFERENCES**

- .1 Canadian Standards Association (CSA International)
  - .1 CAN/CSA C22.1 No.126.1, Metal Cable Tray Systems.
  - .2 CAN/CSA C22.1 No.126.2, Non Metallic Cable Tray Systems.
- .2 National Electrical Manufacturers Association (NEMA)
  - .1 NEMA FG 1, Fibreglass and Cable Tray Systems.
  - .2 NEMA VE 1, Metal Cable Tray Systems.
  - .3 NEMA VE 2, Cable Tray Installation Guidelines.

**1.3 SUBMITTALS**

- .1 Provide submittals in accordance with Division 01 - Submittal Procedures.
- .2 Product Data: submit manufacturer's product data sheets for cable tray indicating dimensions, materials, and finishes, including classifications and certifications.
- .3 Shop Drawings: submit shop drawings showing materials, finish, dimensions, accessories, layout, and installation details.
- .4 Identify types of cabletrays used.
- .5 Show actual cabletray installation details and suspension system.

**PART 2 PRODUCTS**

**2.1 CABLE TROUGH**

- .1 Cabletroughs and fittings: to NEMA FG 1/VE 1 and CAN/CSA C22.1 No. 126.1/2.
- .2 Ladder Ventilated & Non Ventilated wire mesh type, Class A C1 to CAN/CSA C22.2 No.126.1/2.

- .3 Solid covers for complete cabletrough system including fittings.
- .4 Barriers where different voltage systems are in same cabletrough.
- .5 Ground cable trays with bare copper conductor attached to each tray section in accordance with CEC requirements.

## **2.2 SUPPORTS**

- .1 Provide splices, supports for a continuously grounded system as required.

## **2.3 STANDARD OF ACCEPTANCE**

- .1 Legrand Cablofil
- .2 Wiremold
- .3 Code Electric

## **PART 3 EXECUTION**

### **3.1 GENERAL INSTALLATION – POWER & COMMUNICATIONS**

- .1 Provide cable tray in approximate location and general routing as shown on drawings.
- .2 Provide waterfall dropouts when cables exiting all horizontal cable trays.
- .3 Support suspended cable tray from trapeze style hangers with hangers spaced as recommended by the manufacturer based on a maximum load capacity for the tray. Support trays at all corners, offsets and tee fittings
- .4 Where shown and appropriate, support cable tray from wall using a cantilever support arrangement. Cable trays may be supported using wall mounted support on masonry walls or from the building steel only.
- .5 Generally Cable Trays shall be separated at a minimum 450mm from the adjacent wall unless otherwise indicated.
- .6 Cable tray location and mounting heights to be coordinated on site with other trades to provide minimum headroom and serviceability. Verify drawing details to allow for all services run in ceiling spaces. Provide vertical and horizontal offsets as required to suit job site conditions.



- .7 Cable tray sections shall be joined by approved connector plates and rust-resistant (plated) hardware. Torque all hardware as per manufacturer's recommendations.
- .8 Unless otherwise indicated, bond all cable tray with a minimum #6 AWG copper bonding conductor installed continuously within the full length of all cable trays. Securely connect the bond wire to the tray, secured to outside of the tray, at each end and at a minimum of 15m [50'] intervals. Connect bonding conductor to the building ground system at one or both ends.
- .9 Provide pulleys and rollers to install cables.
- .10 Cable tray may require installation of risers, bend, etc. to adjust tray up or down as well as sideways for the tray routing to fit within limits of space available, and to clear other services, ducts, pipes etc. along the route. Routing maybe adjusted somewhat as necessary to enable installation of services under other trades. These field adjustments are to be done at no extra cost to the Owner.
- .11 Where tray runs change elevation, trays shall overlay each other when manufactured waterfall assemblies cannot be used. To prevent cables stress install drop-outs on the top tray when overlap method is to be used. Further, tray sections shall be coupled together to provide some rigidity. This coupling maybe made by using a short length of tray and adjustable elbows or may be coupled by means of common support rods at the tray overlap.
- .12 Sharp metal edges in cable trays which could cut the cable shall be smoothed and the cable dressed away from these edges. Manufacturer surface imperfections shall be touched up with a cold galvanizing coating before installing cable.
- .13 There shall be no wiring joints or splices within the cable tray.

### **3.2 PATHWAY CAPACITY**

- .1 All cable tray pathways, shall have maximum 40% initial fill plus capacity.

END OF SECTION

**1 GENERAL**

**1.1 SECTION INCLUDES**

- .1 Luminaires or bulbs
- .2 Fixtures or luminaire housings
- .3 Poles or light standards

**1.2 RELATED WORK**

- .1 Section 26 05 01 - Electrical General Requirements

**1.3 SHOP DRAWINGS**

- .1 Submit drawings for product approval prior to purchase:
  - .1 Luminaires used in RC cabinet fixtures and in float light standard fixtures
  - .2 Fixtures used on float mounted light standards
  - .3 Three meter poles used as light standards installed on floats
  - .4 Photocell installed on top of fixture on float light standards

**2 PRODUCTS**

**2.1 LUMINAIRE**

- .1 Use luminaire of one manufacturer for all lighting poles.
  - .1 Type 'A' WE-EF VFL530-SE LED c/w Pole mounted bracket 111-0044 RF1-530, Asymmetric side throw beam S60, 3000K, 48W, LED-24/48W/830 #108-1287 or equivalent upon approval by the Engineer.
  - .2 Housing: IP66, Class I or Class II. IK08. Marine-grade die-cast aluminium alloy. 5CE superior corrosion protection including PCS hardware. Silicone CCG® Controlled Compression Gasket.
- .2 Use LED canopy light for all receptacle cabinets on floats.
  - .1 Cooper Lumark QD QuadCast # QDCAST1A or equivalent upon approval by the Engineer.
- .3 Photo control with integrated relay.

**2.2 LUMINAIRE POLES**

- .1 Poles shall be 3 metres c/w 78mm diameter pole top, Marine grade die-cast aluminium alloy or hot dipped galvanized, tapered round poles for float mounted light standards. WE-EF pole or approved equal.
- .2 Tubular steel, one step. Hot dipped galvanised inside and out. Chrome-free conversion coating with superior powdercoat finish in RAL colour to match fixture. Service door with stainless locking screw. Suitable for one cable connecting box. Base plate welded to tubular shaft, flange plate suitable for mounting on floats.

### **3 EXECUTION**

#### **3.1 LUMINAIRE & PHOTOCCELL**

- .1 Mount as indicated on drawings inside lens at top of RC's and on floats.
- .2 As recommended by manufacturer.

**END OF SECTION**

**PART 1 GENERAL**

**1.1 RELATED WORK**

- .1 This Section of the Specification forms part of the Contract Documents and is to be read, interpreted and coordinated with all other parts.

**1.2 SHOP DRAWINGS**

- .1 Submit shop drawings in accordance with Section 26 05 01.
- .2 Shop drawings to include electrical detail of panel, branch breaker type, quantity, ampacity and enclosure dimension.
- .3 Shop drawings to include matching tub and trim details for factory installed low voltage relay cabinets where specified.

**1.3 PLANT ASSEMBLY**

- .1 Install circuit breakers in panelboards before shipment from plant.
- .2 Install and prewire low voltage relays assemblies where indicated.
- .3 In addition to CSA requirements manufacturer's nameplate must show fault current that panel including breakers has been built to withstand.
- .4 All panelboards to be of a common manufacturer.

**1.4 FINISH**

- .1 Panel finish in electrical and equipment rooms and closets to be standard ASA Grey baked enamel for normal power service. Confirm with Consultant prior to shop finishing panels.

**PART 2 PRODUCTS**

**2.1 PANELBOARDS, DOORS AND TRIMS**

- .1 Panelboards: to CSA C22.2 No. 29 and product of one manufacturer.
- .2 Bus and breakers rated for 22 KA symmetrical, minimum, interrupting capacity or as indicated.

- .3 Tin plated aluminum bus with full size neutral.
- .4 Sequence phase bussing with odd numbered breakers on left and even on right, with each breaker identified by permanent number identification as to circuit number.
- .5 Mains, number of circuits and number and size of branch circuit breakers as indicated.
- .6 Provide all necessary connectors and mounting hardware in every space to facilitate installation of future breakers. Provide blank fillers for all spaces.
- .7 Concealed hinges and concealed trim mounting screws, hinged locking door with flush catch.
- .8 Panelboards to have flush doors. (Gasketed where required).
- .9 Provide two keys for each panelboard and key similar voltage panelboards alike.
- .10 Panel tubs to be typically 600mm [20"] wide.
- .11 Provide door within door trims where indicated to facilitate ease of service maintenance Each tub trim cover to be hinged and self-supporting and to swing out to expose breaker cable terminations and wireways. Hinged trim shall be secured with cover screws on opening side by concealed machine screws. Hinged breaker cover shall be recessed into the hinged overall tub cover. Breaker cover shall have latch type closures. Submit details on shop drawings prior to manufacturing.

## **2.2 BREAKERS**

- .1 All breakers to be bolt on type, moulded case, non-adjustable and non-interchangeable trip, single, two and three pole, 120/208(240)V and with trip free position separate from "On" or "Off" positions.
- .2 Two and three pole breakers to have common simultaneous trip and able to be located in any circuit position within the panelboard. Minimum interrupting rating of breakers to be as follows:
  - .1 120/208V panelboards - 10,000 Amps at 250 volts.
- .3 Main breaker to be separately mounted at top or bottom of panel to suit cable entry. When mounted vertically, down position should open breaker.
- .4 Provide circuit breakers with indicated trip ratings as shown in the panelboard schedules.

- .5 Provide at least 10% spare 15 Amp single pole breakers whether indicated or not.
- .6 Provide GFI type breakers as indicated.

### **2.3 PANELBOARD IDENTIFICATION**

- .1 Provide equipment identification in accordance with Section 26 05 01.
- .2 Nameplate for each panelboard size 5 (2 line) engraved as indicated and include panel designation and voltage/phase.
- .3 Complete circuit directory with typewritten card(s) located in slide-in plastic pocket(s) fixed to the back of the related door. Directory card to indicate the panel designation, mains size, voltage/phase and the location and load controlled of each circuit. Include a "letter sized" paper copy of each directory in the project maintenance manual.
- .4 Provide a plasticized typewritten information card fixed to the back of the each panel door. Information card to indicate the panel designation and location, feeder type and size and locations of any controlling contactors and feeder pullboxes. Include a "letter sized" paper copy of each information card in the project maintenance manual.

### **2.4 STANDARD OF ACCEPTANCE**

- .1 Cutler Hammer Type PRL Door within door trim where indicated.
- .2 Schneider, Type NQOD Door within door trim where indicated.
- .3 Siemens Canada.

## **PART 3 EXECUTION**

### **3.1 INSTALLATION**

- .1 Locate panelboards as indicated and mount securely, plumb true and square, to adjoining surfaces.
- .2 Panelboards located in service rooms, mechanical rooms, and electrical rooms to be mounted on unistrut supports.
- .3 Mount panelboards to height given in Section 26 05 01 or as indicated.

- .4 Connect loads to circuits as indicated.
- .5 Connect neutral conductors to common neutral bus with respective neutral identified.

END OF SECTION

## **1 GENERAL**

### **1.1 REFERENCES**

- .1 CSA C22.2 No. 5, Moulded-Case Circuit Breakers, Moulded-Case Switches and Circuit-Breaker Enclosures (Tri-national standard with UL 489, tenth edition, and the second edition of NMX-J-266-ANCE)
- .2 Section 26 24 16 – Panelboards Breaker Type

### **1.2 PLANT ASSEMBLY**

- .1 Assemble panelboard interior and install circuit breakers before shipment.
- .2 Panelboards to fit available space within electrical kiosk enclosures.

## **2 PRODUCTS**

### **2.1 MAIN DISTRIBUTION PANEL (MDP) ENCLOSURE**

- .1 Enclosure (kiosk) shall be sized to fit the 120/208V, 225A panelboard, main breaker or safety switch (if separate components), gutter box or wireway, isolated neutral and ground busses and all required conduit and cable connections.
- .2 Kiosk shall be 12 gauge stainless steel or 3.2mm marine grade aluminium 5052-H32 powder coated ASA grey, rated NEMA 3R:
  - .1 bullet style grease-able hinges;
  - .2 drip edge on top and sides of doors;
  - .3 weather strip around all doors.
  - .4 roof overhang on front;



- .5 gutter box for bottom cable entry & exit;
  - .6 corrosion proof 3 point latch on each door with 9mm pad lock loop and hasp;
  - .7 all hardware shall be stainless steel.
- 
- .3 Submit shop drawing of kiosk and all components to Engineer for approval prior to procurement.
  - .4 Panelboard, main breaker or safety switch, and other components mounted to backboard inside kiosk. Ground bus and neutral bus mounted to backboard on insulated standoffs.
  - .5 Kiosk shall be bolted to wharf deck with minimum 19mm galvanized bolts. Gutter box to extend beyond wharf edge for cable access under wharf.
  - .6 Nameplate is 100 x 200mm black lamacoid with white lettering, machine-screw fixed to kiosk door.
  - .7 Supplier shall be Valid Manufacturing Ltd. or approved equal.

## **2.2 MAIN DISTRIBUTION PANELBOARD**

- .1 Panelboard shall be rated 120/208V, 225A with 200A main breaker, branch breakers, 100% neutral and lugs to fit cables from service entrance supply and to loads.
- .2 Panelboard shall be mounted on backboard inside kiosk and shall be CSA NEMA Type 3R construction. Submit shop drawings to Engineer for approval.
- .3 Panels shall be moulded-case, circuit breaker type, 22 kA interrupting rating.
- .4 Main bus bars shall be of tin-plated copper and equipped with pressure type solderless lugs. All bus work shall be suitably supported to withstand maximum short circuit current of 22 kA RMS amperes symmetrical.

- .5 Unused circuit positions shall be closed with substantial covers which require tools for removal.
- .6 Panelboards shall be fitted with a branch circuit grounding terminal bus firmly bonded to the inside of the panel enclosure consisting of a copper grounding bus with one terminal for each circuit position available in the panel. Branch circuit equipment grounding conductors shall terminate at this ground bus. This ground bus shall be connected to the isolated ground bus mounted outside the panelboard.
- .7 The neutral bus shall be attached but isolated from the panelboard enclosure. Branch circuit neutrals shall terminate on this neutral bus. The neutral bus shall be connected to the isolated neutral bus mounted outside the panelboard.
- .8 All breakers shall be of the same manufacturer.
- .9 Breakers shall be bolt-on. Plug-in type circuit breakers shall not be used.
- .10 Two- and three-pole circuit breakers shall have a common tripping mechanism and single handle. Handle ties are not acceptable.
- .11 Panelboards shall be as manufactured by Cutler-Hammer, Square D, Schneider Group, Moeller Electric, or approved equal.

### **3 EXECUTION**

#### **3.1 INSTALLATION**

- .1 Bolt panels securely to backplane inside electrical kiosk.
- .2 Connect the isolated neutral bus to the isolated ground bus mounted outside the panelboard. Connect the isolated ground bus to the earth ground electrode. Identify all ground bus wiring connections.

- .3 Upon completion of testing and commissioning, install permanent engraved circuit directory on the inside face of the panelboard.

**END OF SECTION**

**1 GENERAL**

**1.1 REFERENCES**

- .1 CSA C22.2 No. 5, Moulded-Case Circuit Breakers, Moulded-Case Switches and Circuit-Breaker Enclosures (Tri-national standard with UL 489, tenth edition, and the second edition of NMX-J-266-ANCE)
- .2 Section 26 24 16 – Panelboards Breaker Type

**1.2 PLANT ASSEMBLY**

- .1 Assemble panelboard interior and install circuit breakers before shipment.
- .2 Panelboards to be custom-fabricated to fit available space within TRC and RC enclosures.

**2 PRODUCTS**

**2.1 PANELBOARDS**

- .1 Panelboards for RC's: 125A 120/208V 3 phase 4 wire 12 circuit 12" wide with no main breaker, product of same manufacturer as MDP's.
- .2 Panelboards shall be of CSA NEMA Type 3R construction.
- .3 Sequence phase bussing with odd numbered breakers on left and even on right, with each breaker identified by permanent number identification as to circuit number and phase.
- .4 Neutral bus of same ampere rating as phase buses.
- .5 Panelboards shall be stainless steel or non-metallic enclosures with gasketed covers.
- .6 Main bus bars shall be of tin-plated EC and equipped with pressure type solderless lugs. All bus work shall be suitably supported to withstand maximum short circuit current of 22 kA RMS amperes symmetrical.
- .7 Panelboards shall be moulded-case, circuit breaker type, with 10kA rated breakers.
- .8 Provide all necessary jumpers, connectors, etc., for simple field installation of future circuit breakers.

**2.1 PANELBOARDS (cont.)**

- .9 Unused circuit positions shall be closed with substantial covers which require tools for removal.
- .10 All panelboards shall have a branch circuit grounding terminal bus firmly bonded to the inside of the panelboard case consisting of a length of copper grounding bus with one terminal for each circuit position available in the panel. Branch circuit equipment grounding conductors shall terminate at this ground bus.
- .11 The neutral bus shall be attached but isolated from the enclosure and not connected to the local ground bus. Branch circuit neutrals and the transformer secondary neutral (where applicable) shall terminate on this neutral bus. The neutral bus shall be wired to connect to the MDP neutral bus on shore.
- .12 All breakers in panelboards shall be of the same manufacturer as panelboard.
- .13 All breakers for RC's shall be GFCI Class 'A' protected.
- .14 Plug-in type circuit breakers shall not be used.
- .15 Two- and three-pole circuit breakers shall have a common tripping mechanism and single handle. Handle ties are not acceptable.
- .16 Panelboards shall be as manufactured by Cutler-Hammer, Square D, Schneider Group, Moeller Electric, or approved equal.

**3 EXECUTION**

**3.1 INSTALLATION**

- .1 Provide all required steel supports in RC enclosures.
- .2 Connect neutral conductors to common neutral bus with respective neutral conductor identified with respect to ungrounded conductors.
- .3 Upon completion of testing and commissioning, install permanent engraved circuit directory on the inside face of each panelboard.
- .4 Panel schedules for RCs shall show Phases A, B, C, breaker ratings, panel ratings, and description of branch circuit loads. Description of circuits feeding receptacles shall include the receptacle CSA configuration designation.

END OF SECTION

**1 GENERAL**

**1.1 SHOP DRAWINGS AND PRODUCT DATA**

- .1 Submit shop drawings and product data for enclosures and equipment including detailed fabrication drawings showing materials of construction and assembly.

**2 PRODUCTS**

**2.1 EQUIPMENT - GENERAL**

- .1 Outdoor weatherproof enclosures constructed of marine grade aluminum and as shown on the drawings.
- .2 Removable enclosure panels with formed edges, external component fasteners removable only from inside enclosure.
- .3 Doors: hinged, with padlocking means.
- .4 Hinges: heavy duty, stainless steel, non-removable pin for secure compartments.

**2.2 MDP ENCLOSURE**

- .1 Provide enclosure with cable entry, wireway, panelboard, isolated neutral bus, isolated ground bus and all fittings required for a safe and functioning main distribution panel with neutral grounding and bond-to-ground systems.

**2.3 RC ENCLOSURES: OWNER-SUPPLIED**

- .1 Pick up RC enclosures shells, from Owner's storage at Steveson Harbour, 12740 Trites Road, Richmond BC, V7E 3R8, (604) 272-5539.
- .2 Internal components to be installed by electrical contractor include panel, breakers, receptacles, luminaires, all fittings and connections.

**3 EXECUTION**

**3.1 INSTALLATION**

- .1 Verify that components are assembled inside enclosure in accordance with reviewed shop drawings. Adjust or revise assembly if required.
- .2 Obtain local CSA approval of completed assembly.

- .3 Install equipment in locations as per drawings.

**END OF SECTION**

**1 GENERAL**

**1.1 RELATED SECTIONS**

- .1 Section 26 05 01 - Electrical General Requirements

**2 PRODUCTS**

**2.1 RECEPTACLES**

- .1 All receptacles shall be twist-lock, marine grade, yellow colour.
- .2 Receptacles in RC interiors shall be single, twist-lock, marine grade, with melamine body and nylon face. Receptacles shall be as follows:
  - .1 20 A, L5-20R, Hubbell HBL 23CM10 or approved equal
  - .2 30 A, L5-30R, Hubbell HBL 26CM10 or approved equal
  - .3 50 A, L6-50R, Hubbell HBL 63 CM70 or approved equal.

**3 EXECUTION**

**3.1 RECEPTACLES**

- .1 Mount receptacles securely within RC's as indicated.

**END OF SECTION**













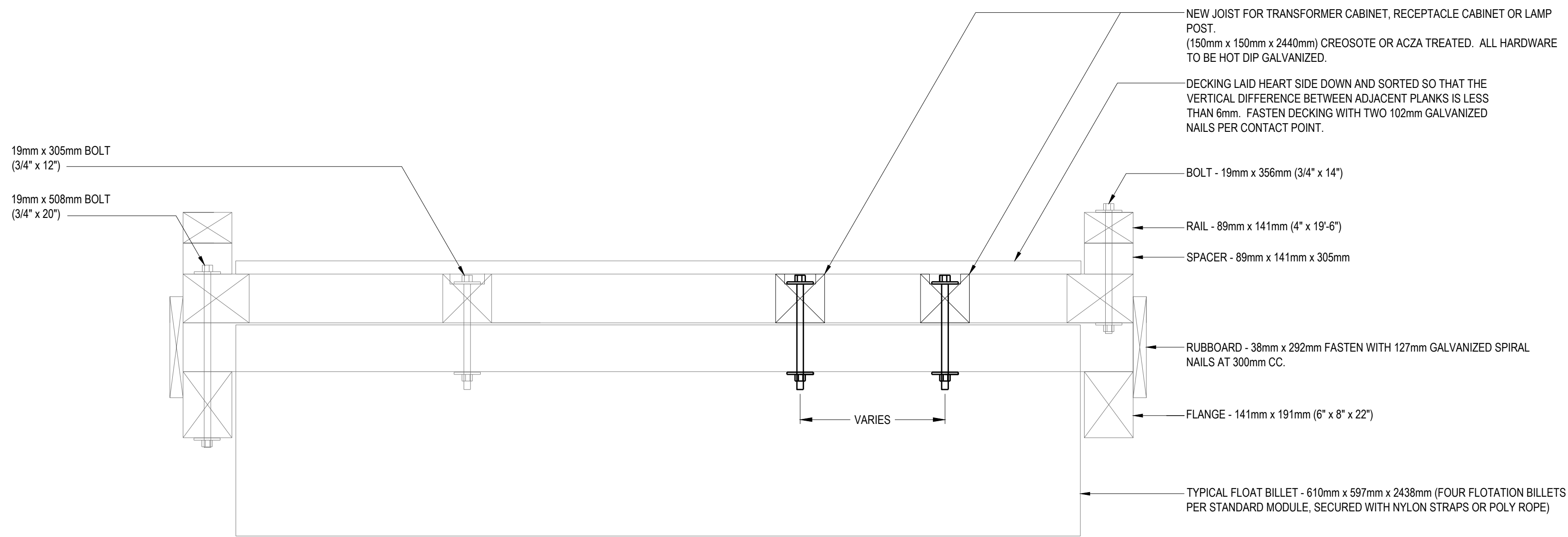

1 TYPICAL CROSS-SECTION OF EXISTING 2743mm (9'-0") WIDE FLOAT  
E004 SCALE: N.T.S.

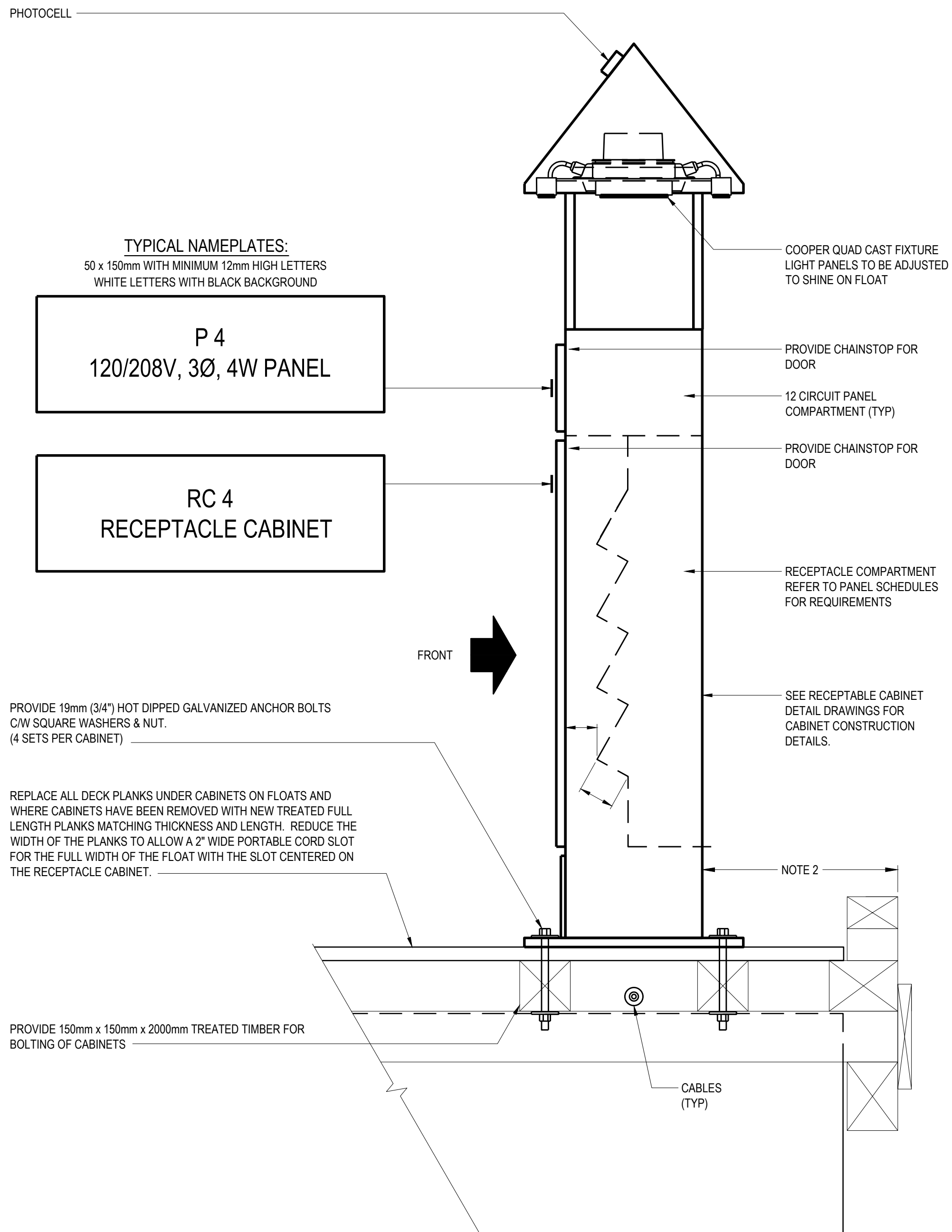

2 RECEPTACLE CABINET (RC) DETAIL ON A FLOAT  
E004 SCALE: N.T.S.

**GENERAL NOTES:**

- TIGHTEN ALL ANCHOR BOLTS TO 80 FOOT POUNDS.
- OBTAIN REQUIRED CLEARANCES FROM HARBOUR MASTER FOR EACH CABINET ON EACH FLOAT PRIOR TO INSTALLATION.

**KEYNOTES:**

- MODIFY RECEPTACLE MOUNTING PLATE LOCATION AND DIMENSIONS TO ACCOMMODATE ALL RECEPTABLES AND THEIR CORRESPONDING PLUG AND CABLE ASSEMBLIES.
- RECEPTACLE SHALL BE SINGLE, TWIST LOCK MARINE GRADE, WITH MELAMINE BODY AND NYLON.
- REPLACE CABTYRE SUPPORT KELLEMS GRIPS, RE-ARRANGE AND TIDY UP CABLES AS NECESSARY, KELLEMS GRIPS - DOUBLE EYE, DOUBLE WEAVE, STAINLESS STEEL.
- REPLACE SUPPORT HARDWARE WITH STAINLESS STEEL HARDWARE AS NECESSARY. RE-ARRANGE AND TIDY UP CABLES AS NECESSARY.

**PRELIMINARY**  
NOT FOR CONSTRUCTION

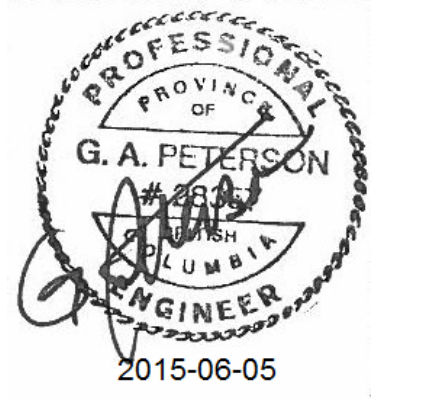

**DO NOT SCALE DRAWINGS**

5		
4		
3		
2		
1	RE-ISSUED FOR TENDER	15/06/05
0	ISSUED FOR TENDER	15/03/31

Revision/Revision	Description/Description	Date/Date
-------------------	-------------------------	-----------

Client/client  
**FISHERIES AND OCEANS SMALL CRAFT HARBOURS**  
401 BURRARD STREET, SUITE 200  
VANCOUVER, B.C.

Project title/Titre du projet  
MAPLE RIDGE, B.C.  
**ELECTRICAL RECONSTRUCTION - KANAKA SMALL CRAFT HARBOUR**

Approved by/Approve par

Designed by/Concept par  
G.P./T.D.

Drawn by/Dessine par  
P.P.

PWGC Project Manager/Administrateur de Projets TPSGC

PWGC, Architectural and Engineering Resources Manager/Ressources Architectural et de Directeur d'Ingénierie, TPSGC

Client/client  
DFG - SCH

Drawing title/Titre du dessin

**RECEPTACLE CABINET (RC) AND FLOAT DETAILS**

Project No./No. du projet <b>131-19108-04</b>	Sheet/Feuille <b>E004</b> 4 OF 4	Revision no./La Révision no. <b>0</b>
--	--	--

Plot Date: June 5, 2015 3:43 PM  
 Plot Name: Y:\PROJECTS\131-19108-04 DFG SCH KANAKA LPSR\CONSTRUCTION\ELECTRICAL\CABINET RC AND FLOAT DETAIL.DWG  
 Plotted by: Papanikolaou



<b>Appendix 1 - Aluminum Kiosk Drawings</b>	
AK-001	Aluminum Kiosk
AK-002	Aluminum Kiosk
AK-003	Aluminum Kiosk
AK-004	Aluminum Kiosk



ITEM NO.	DWG No.	DESCRIPTION	Default/ QTY.
1	002	BASE PLATE	1
2	002	BOX SECTION ASSEMBLY	1
3	003	HINGED PLATE ASSEMBLY	1
4	002	LOWER DOOR ASSEMBLY	1
5	002	UPPER DOOR ASSEMBLY	1
6	002	BREAKER PANEL ASSEMBLY	1
7	004	ROOF CAP ASSEMBLY	1
8	004	ROOF SUPPORTS	4

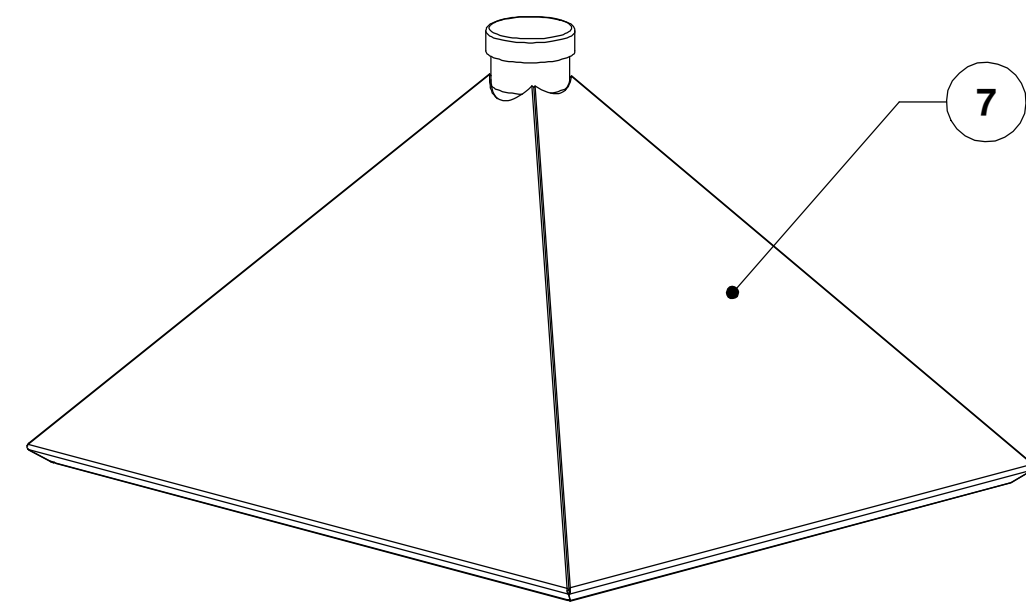

DOORS ARE TETHERED WITH 1/16" S.S. CABLE NOT TO OPEN BEYOND 100°

DOOR HINGES MAY BE LOCATED ON EITHER SIDE OF THE CABINET IN CONSIDERATION OF WIND DIRECTION AT THE SUBJECT HARBOUR. CONSULTATION WITH THE ENGINEER IS REQUIRED

HINGES WITH GREASE NIPPLE (TYP.)

STAINLESS STEEL KEYED ALIKE RECESSED T HANDLE LOCKS, LIP AND WEATHER STRIPPING ALL AROUND DOORS. TYP. ALL DOORS, INSTALL AS PER MANUFACTURERS INSTRUCTIONS.

HINGED PLATE FOR RECEPICALS

2 RECEPTACLES PER ROW

12 CCT PANEL CUTOUT REQUIRED (SEE DWG AK-003)

**FOR REFERENCE ONLY**

SECTION A-A  
SCALE 1 : 8

Fisheries & Oceans / Pêches et Océans

Small Craft Harbours Branch

TITLE: **ALUMINUM KIOSK**

SIZE DWG. NO. REV  
**D** AK-001

SCALE: WEIGHT: SHEET 1 OF 1

UNLESS OTHERWISE SPECIFIED:		DATE	NAME
DRAWN	TOLERANCES:		W.S.L.
CHECKED	FRACTIONAL ±		PL
ENG APPR	ANGULAR MATCH ±		MB
MFG APPR	TWO PLACE DECIMAL ±		
C.I.A.	THREE PLACE DECIMAL ±		
COMMENTS:	INTERPRET GEOMETRIC TOLERANCING PER:		
	MATERIAL: ..		
NEXT ASSY	FINISH: ..		
APPLICATION	DO NOT SCALE DRAWING		

PROPRIETARY AND CONFIDENTIAL  
THE INFORMATION CONTAINED IN THIS DRAWING IS THE SOLE PROPERTY OF HER MAJESTY'S GOVERNMENT OF CANADA. ANY REPRODUCTION IN PART OR AS A WHOLE WITHOUT THE WRITTEN PERMISSION OF HER MAJESTY'S GOVERNMENT OF CANADA IS PROHIBITED.

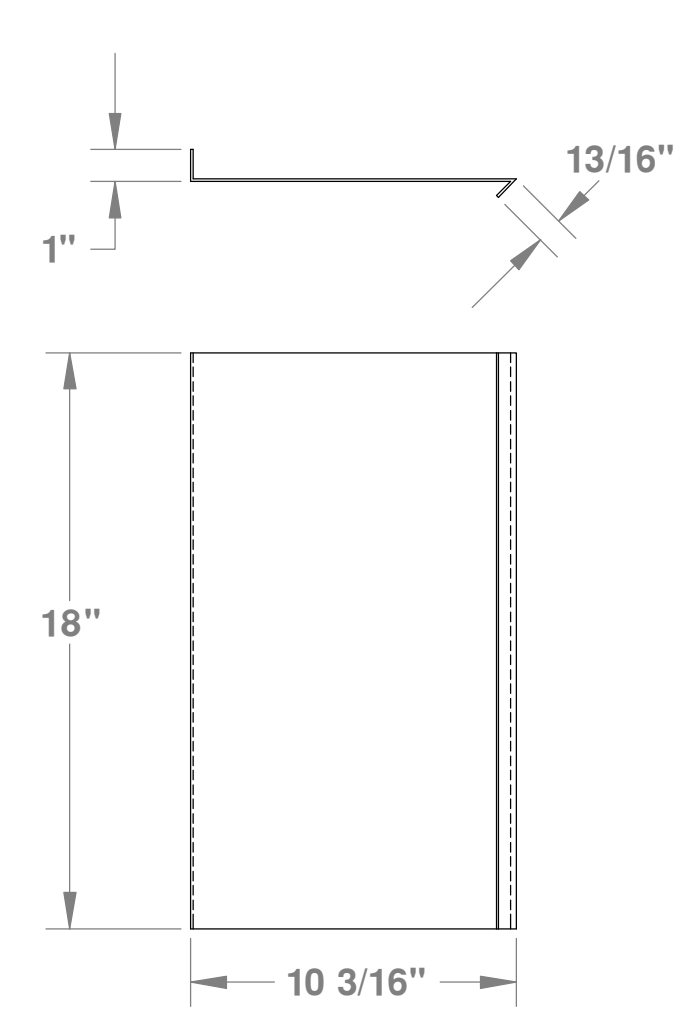
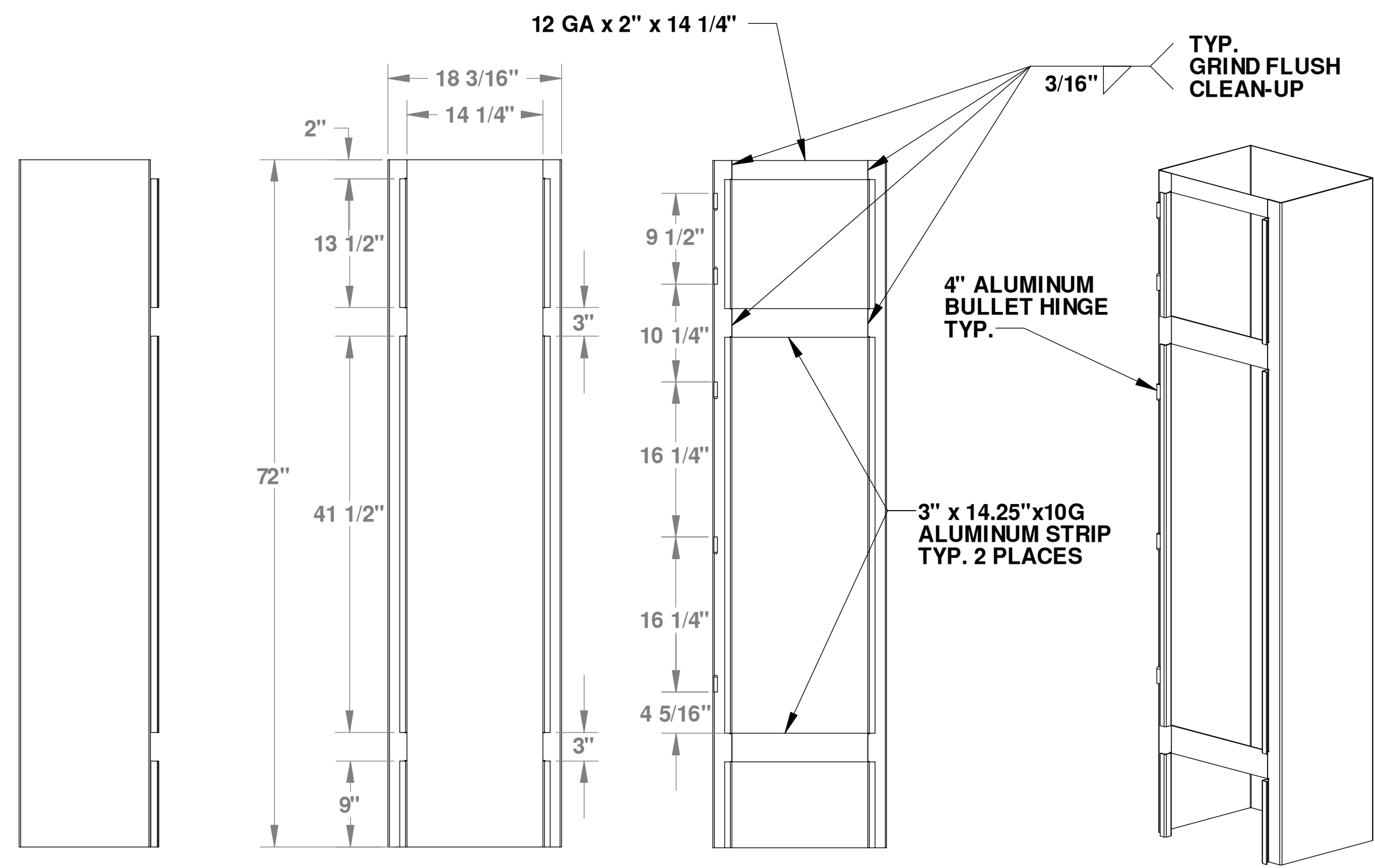

**DIVIDER PLATE**  
 MATERIAL: 12 GAUGE ALUMINUM  
 1 REQUIRED  
 SCALE: 1/2"=1'-0"

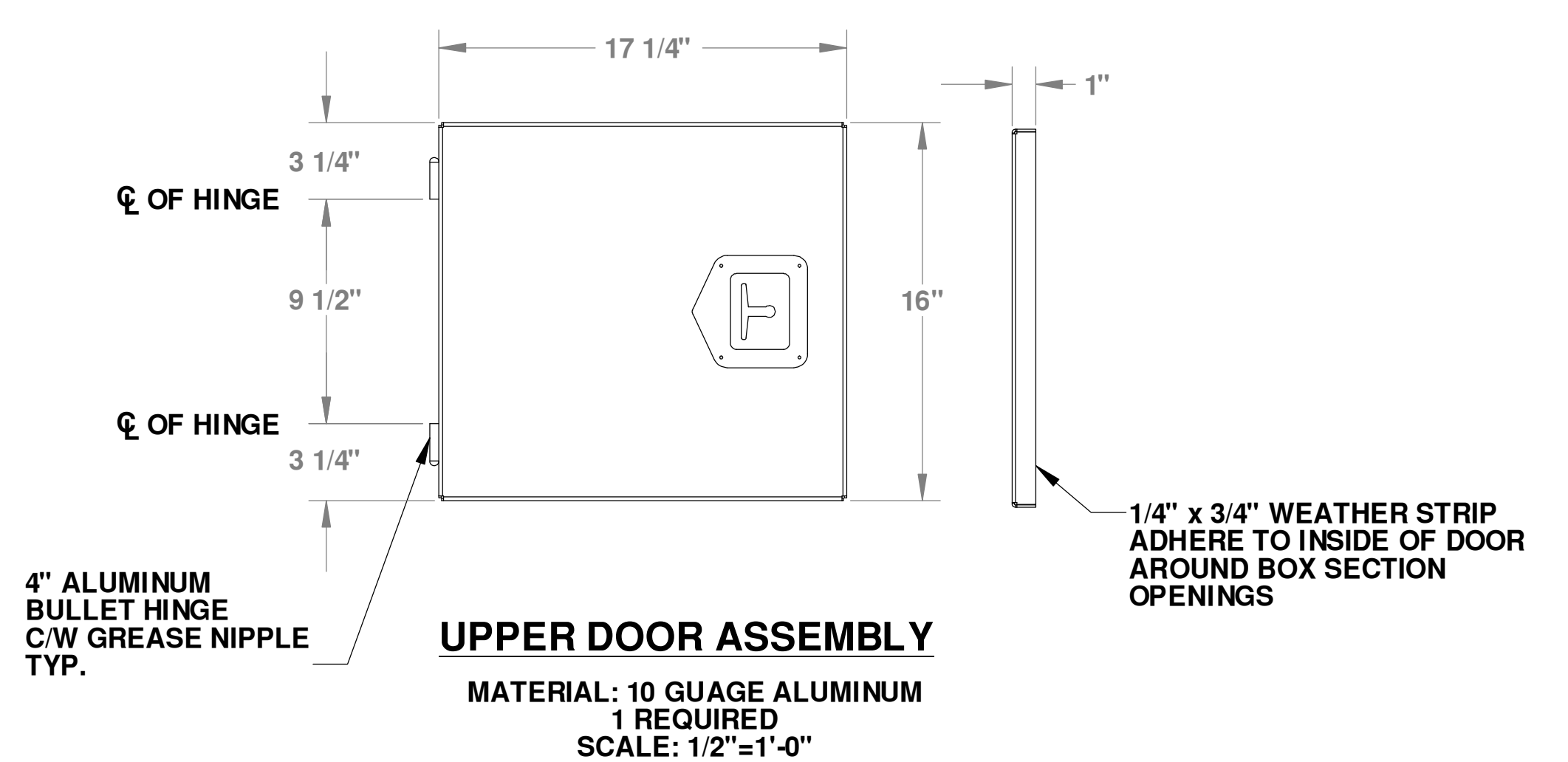

**UPPER DOOR ASSEMBLY**  
 MATERIAL: 10 GAUGE ALUMINUM  
 1 REQUIRED  
 SCALE: 1/2"=1'-0"

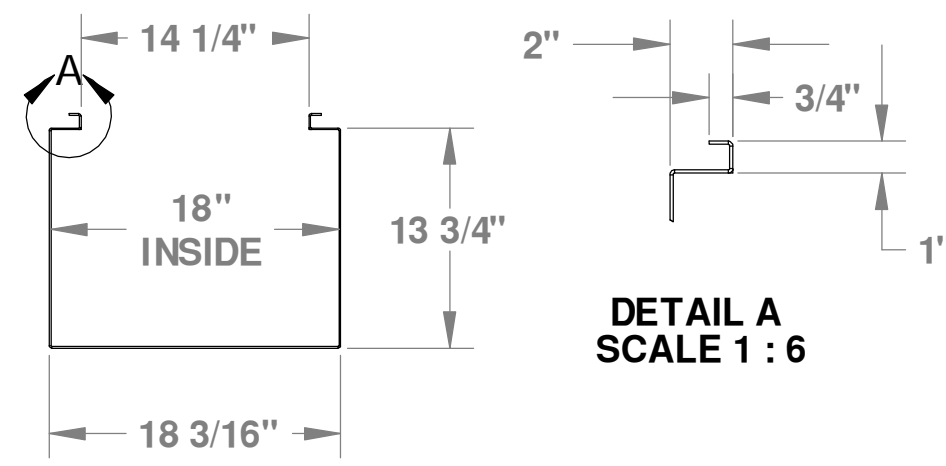

**BOX SECTION ASSEMBLY**  
 MATERIAL: 10 GAUGE ALUMINUM  
 1 REQUIRED  
 SCALE: 1"=1'-0"

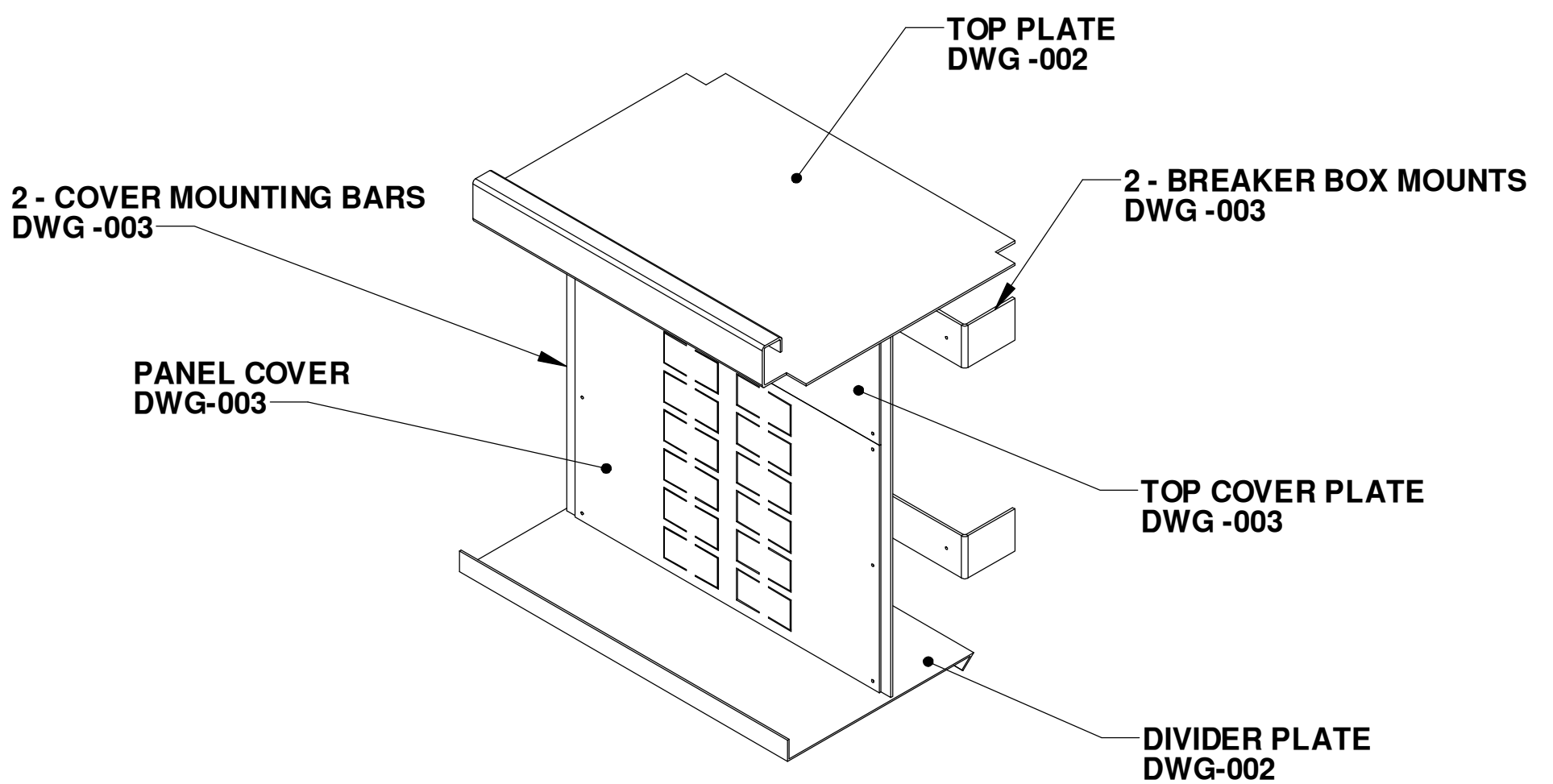

**BREAKER PANEL ASSEMBLY**

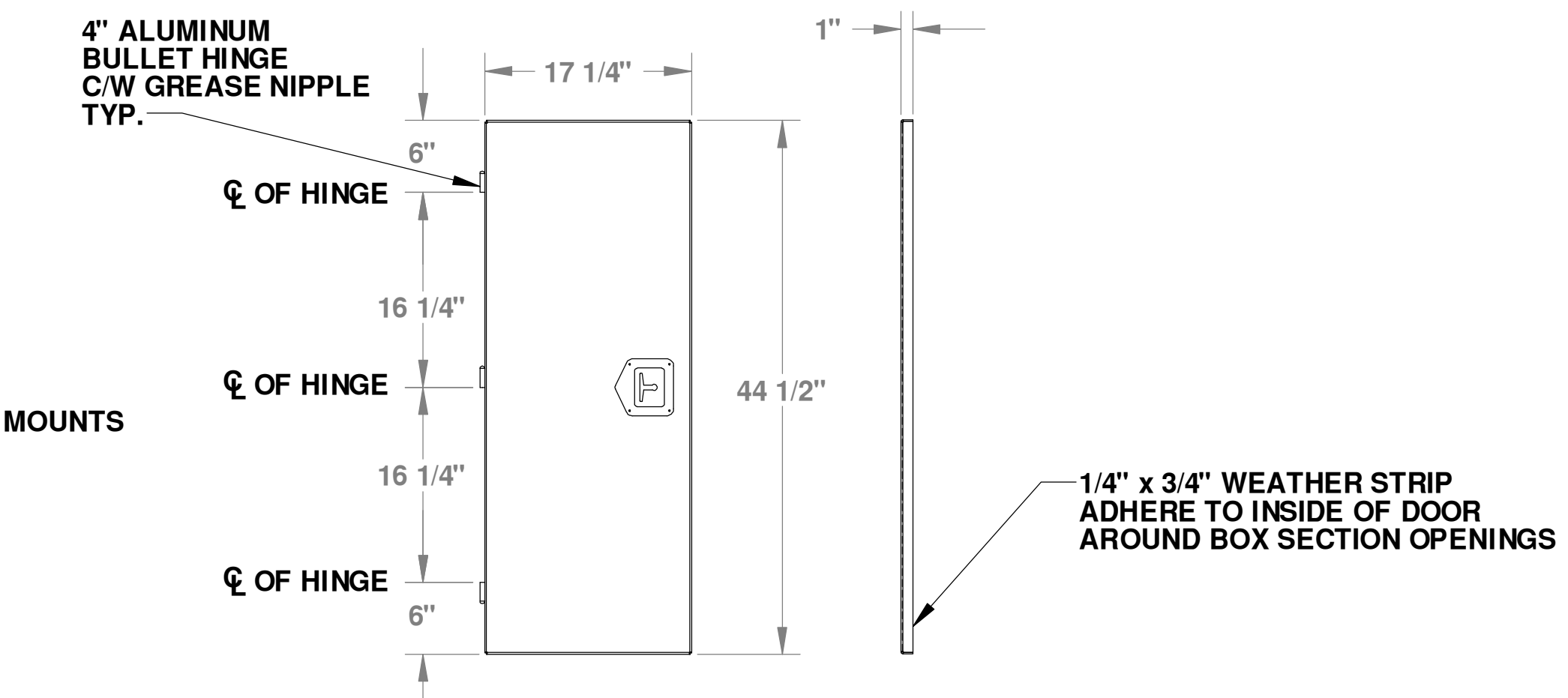

**LOWER DOOR ASSEMBLY**  
 MATERIAL: 10 GAUGE ALUMINUM  
 1 REQUIRED  
 SCALE: 1"=1'-0"

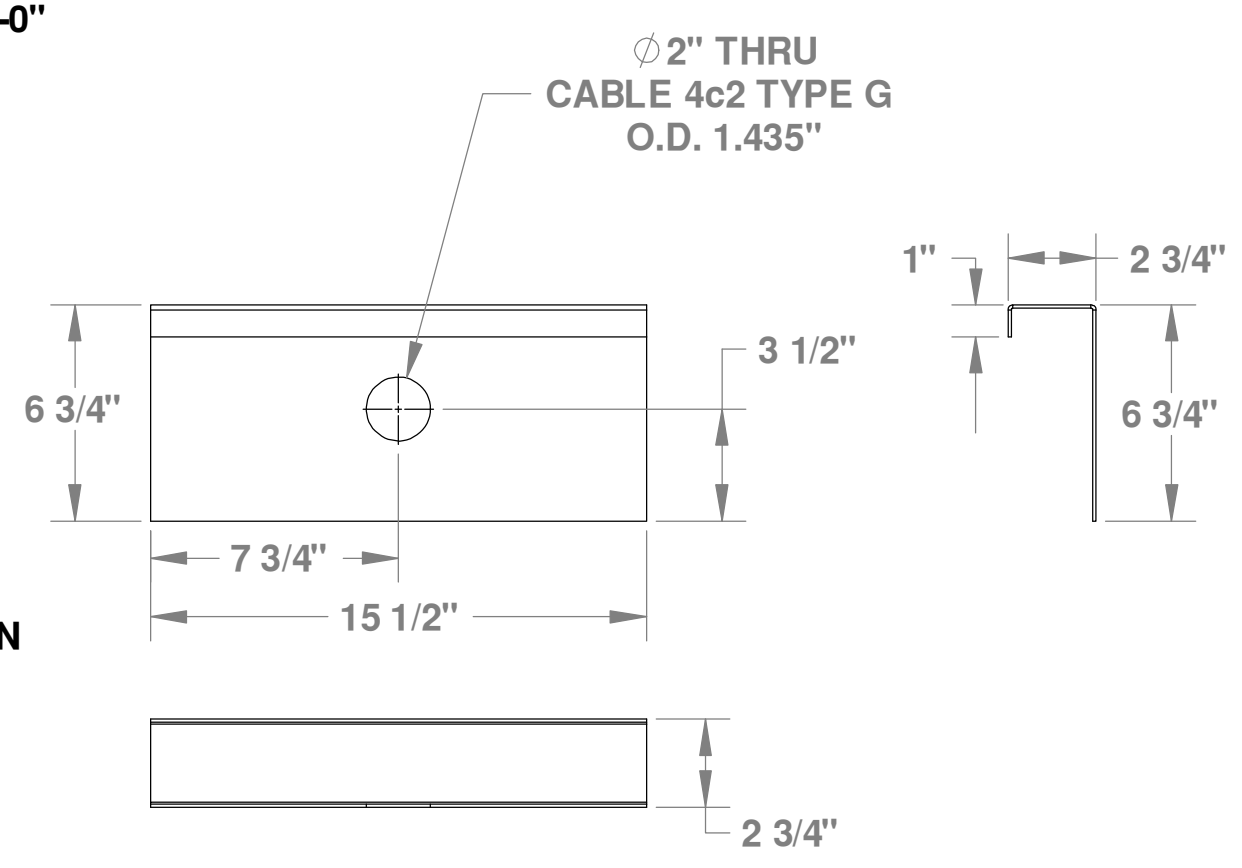

**MOUNTING PLATE**  
 MATERIAL: 10 GAUGE ALUMINUM  
 1 REQUIRED  
 SCALE: 1/2"=1'-0"

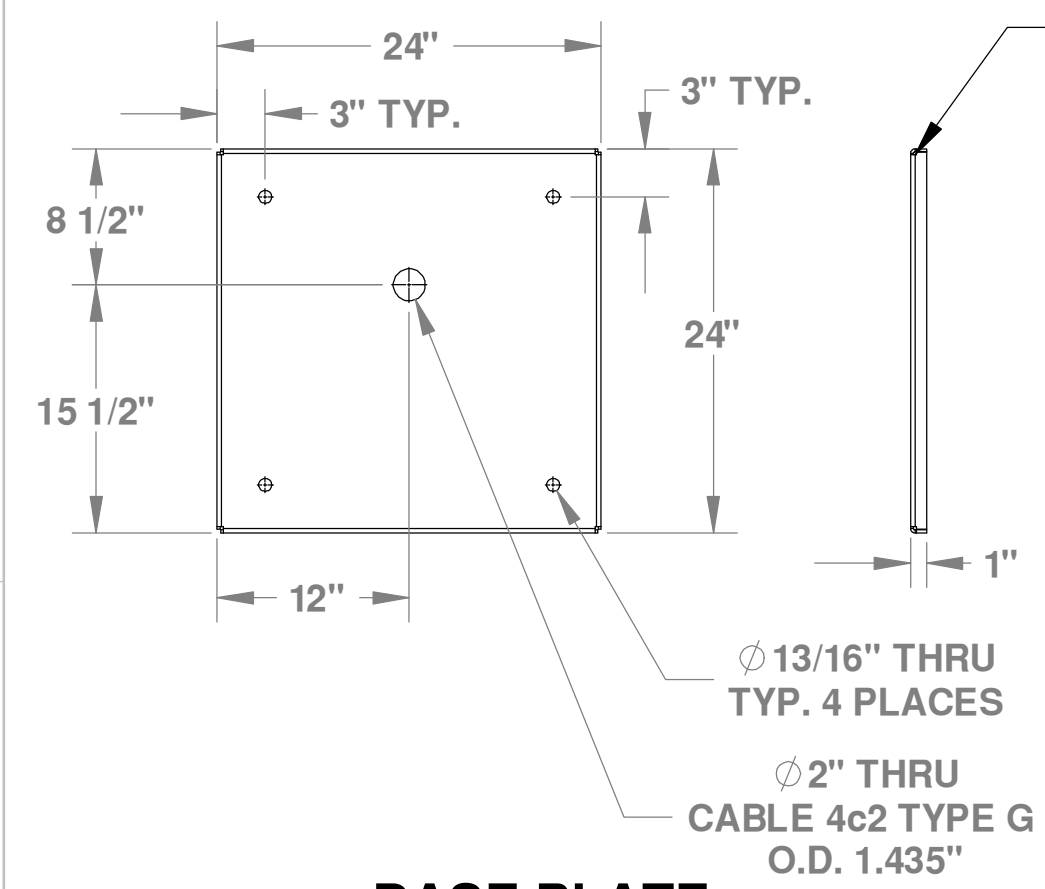

**BASE PLATE**  
 MATERIAL: ALUMINUM 3/16" PLATE  
 1 REQUIRED  
 SCALE: 1"=1'-0"

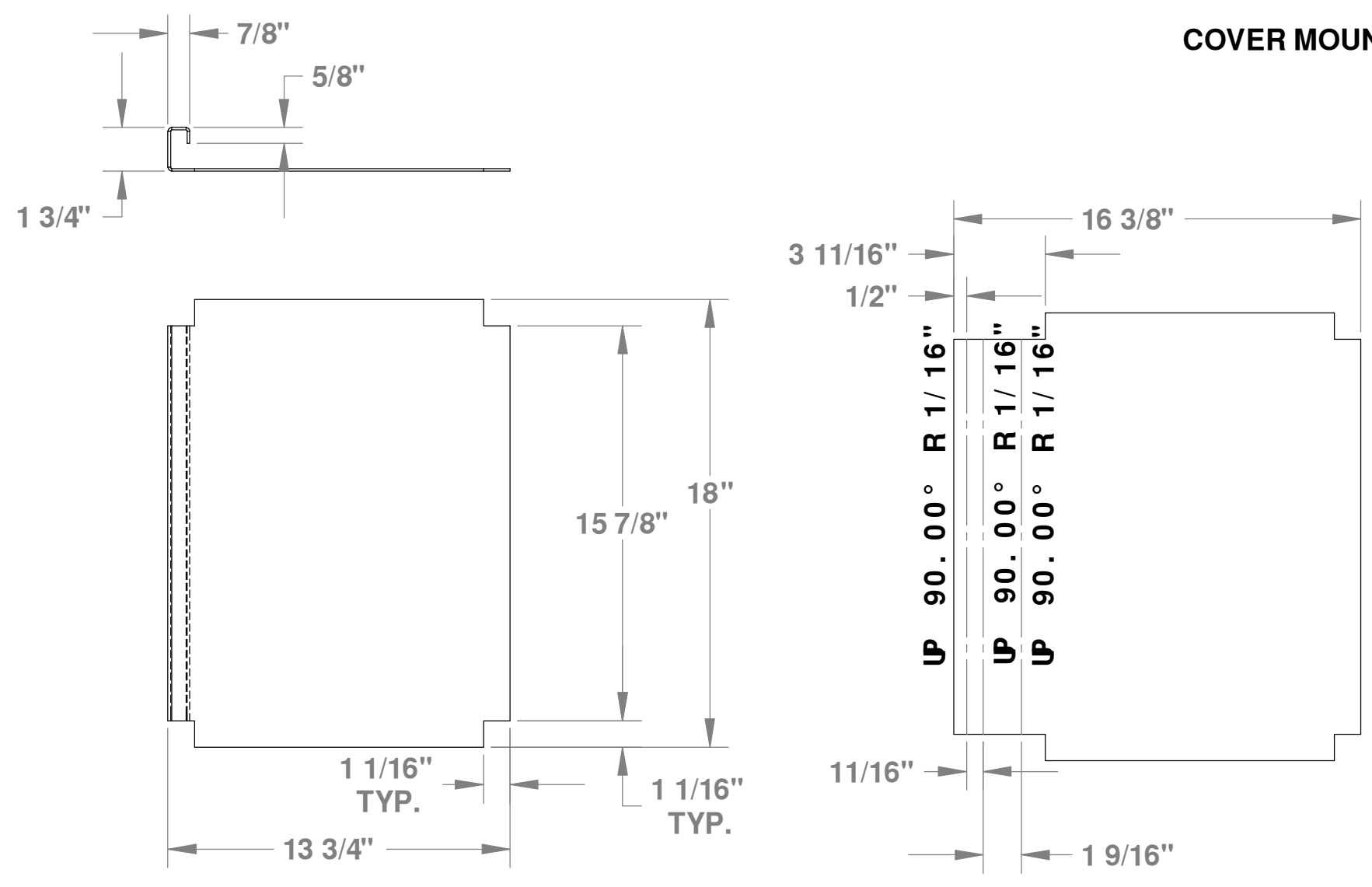

**TOP PLATE**  
 MATERIAL: 10 GAUGE ALUMINUM  
 1 REQUIRED  
 SCALE: 1/2"=1'-0"

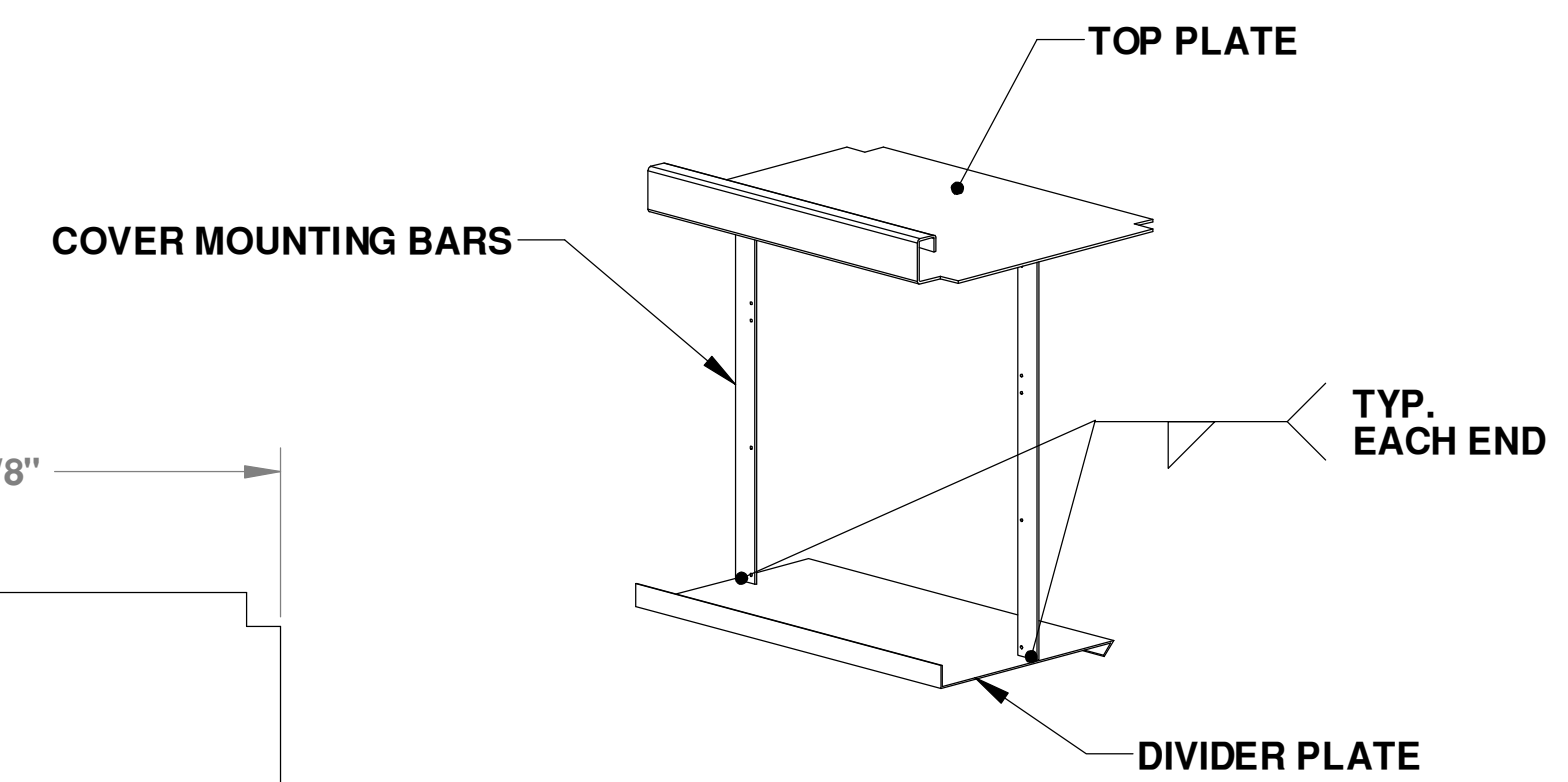

**BREAKER PANEL ASSEMBLY LAYOUT**

Fisheries & Oceans / Pêches et Océans  
 Small Craft Harbours Branch

UNLESS OTHERWISE SPECIFIED:		DATE	NAME
DIMENSIONS ARE IN INCHES			WSL
TOLERANCES:			PL
FRACTIONAL ±			MB
ANGULAR MATCH ±			
TWO PLACE DECIMAL ±			
THREE PLACE DECIMAL ±			
MATERIAL:			
INTERPRET GEOMETRIC TOLERANCING PER:			
MATERIAL:			
FINISH:			
COMMENTS:			
NEXT ASSY:	USED ON:	APPLICATION:	DO NOT SCALE DRAWING

TITLE: ALUMINUM KIOSK		
SIZE: D	DWG. NO.: AK-002	REV:
SCALE: 1:12	WEIGHT:	SHEET 1 OF 1



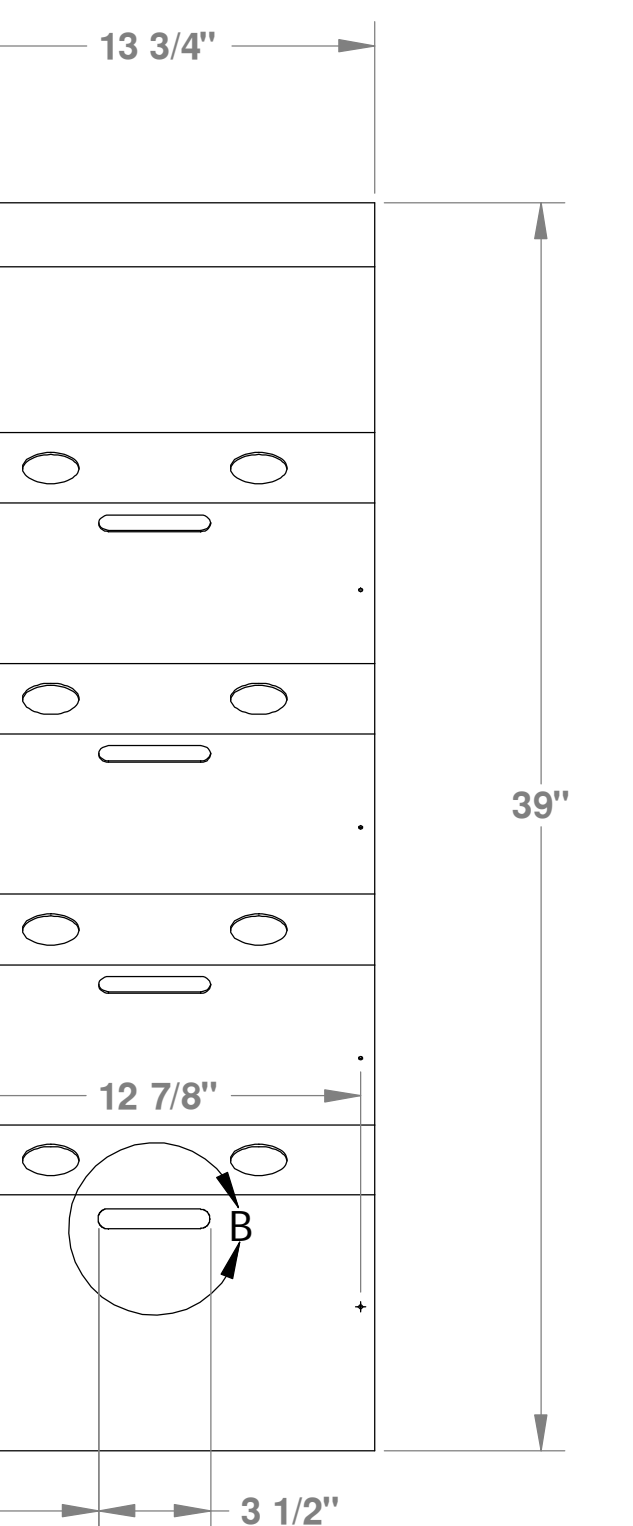
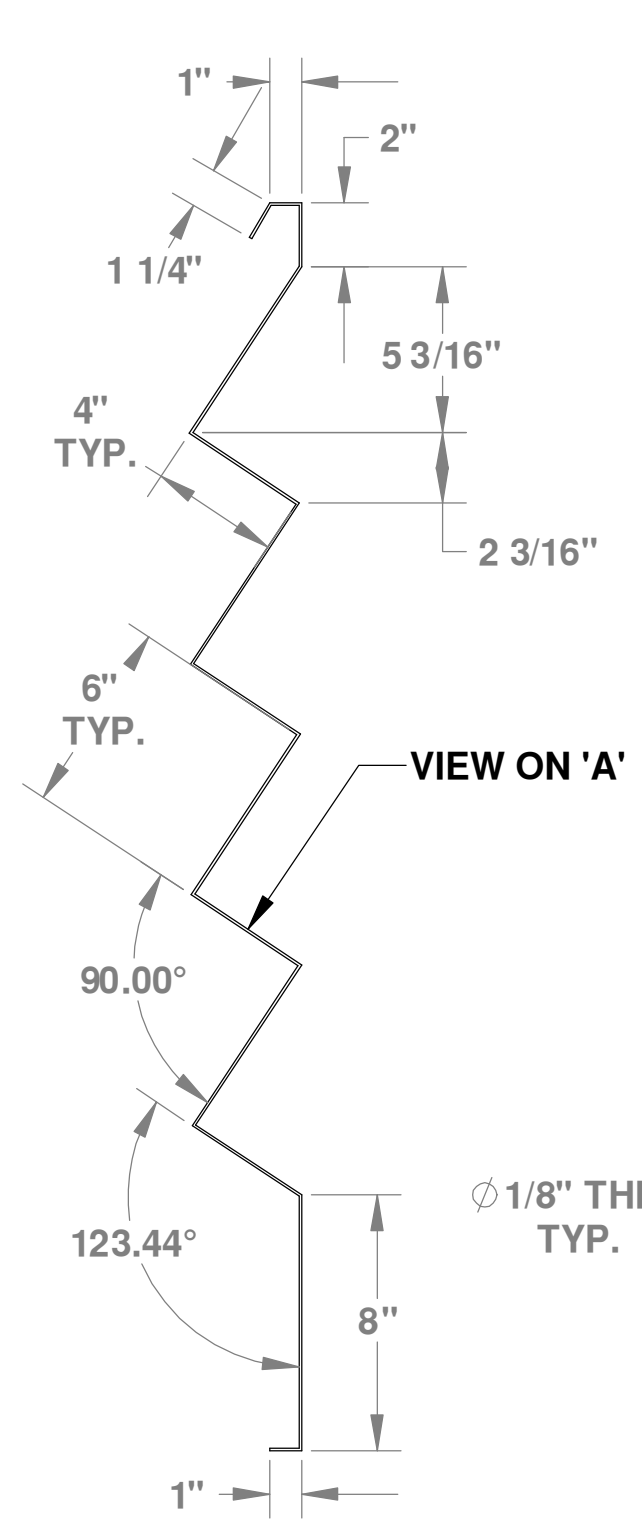

**HINGE PLATE**  
 MATERIAL: 12 GAUGE ALUMINUM  
 1 REQUIRED  
 1/2" = 1'-0"

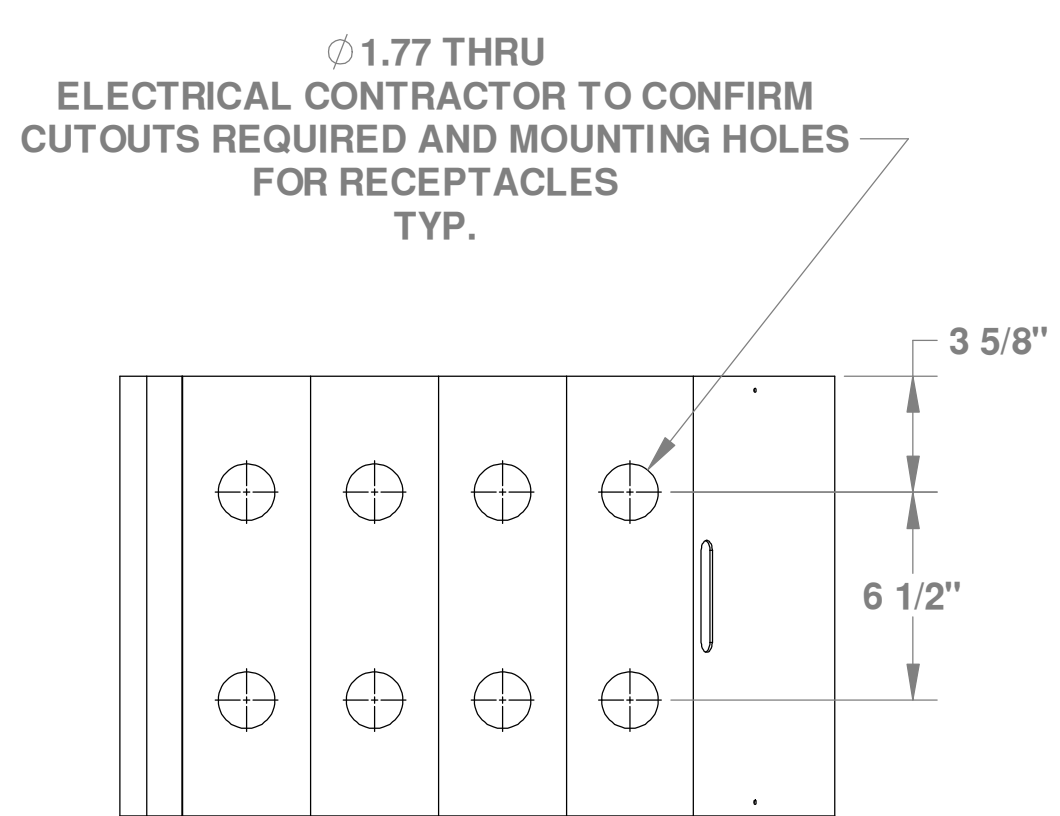

**VIEW ON 'A'**

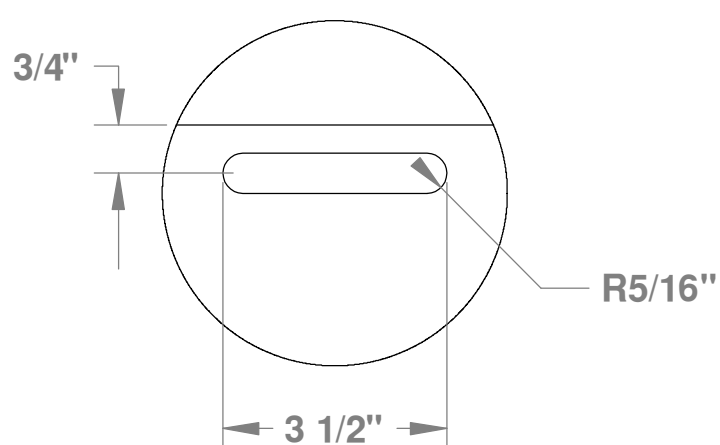

**DETAIL B**  
 SCALE 1 : 3

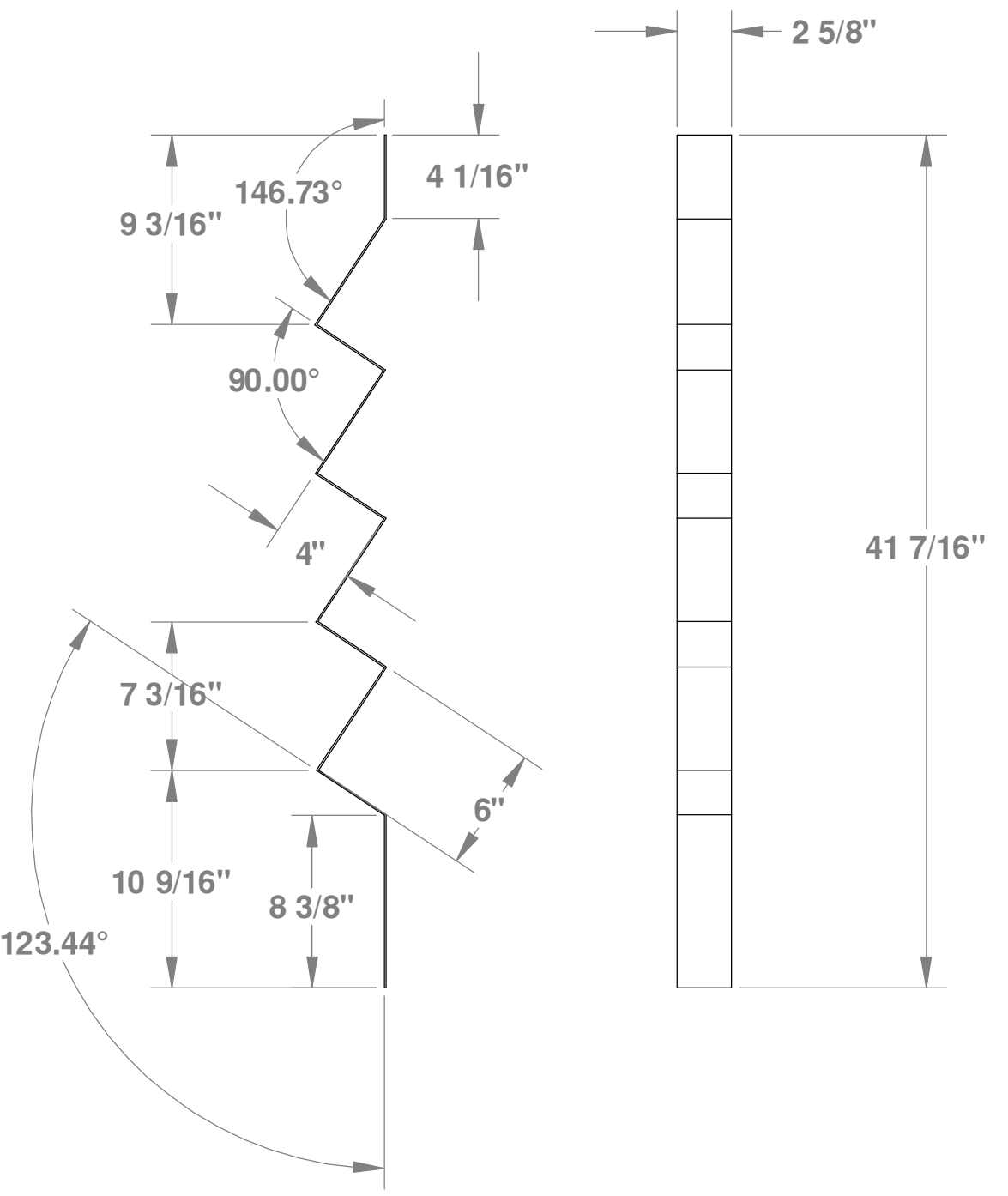

**BACKING PLATE**

MATERIAL: 12 GAUGE ALUMINUM  
 2 REQUIRED  
 1/2" = 1'-0"

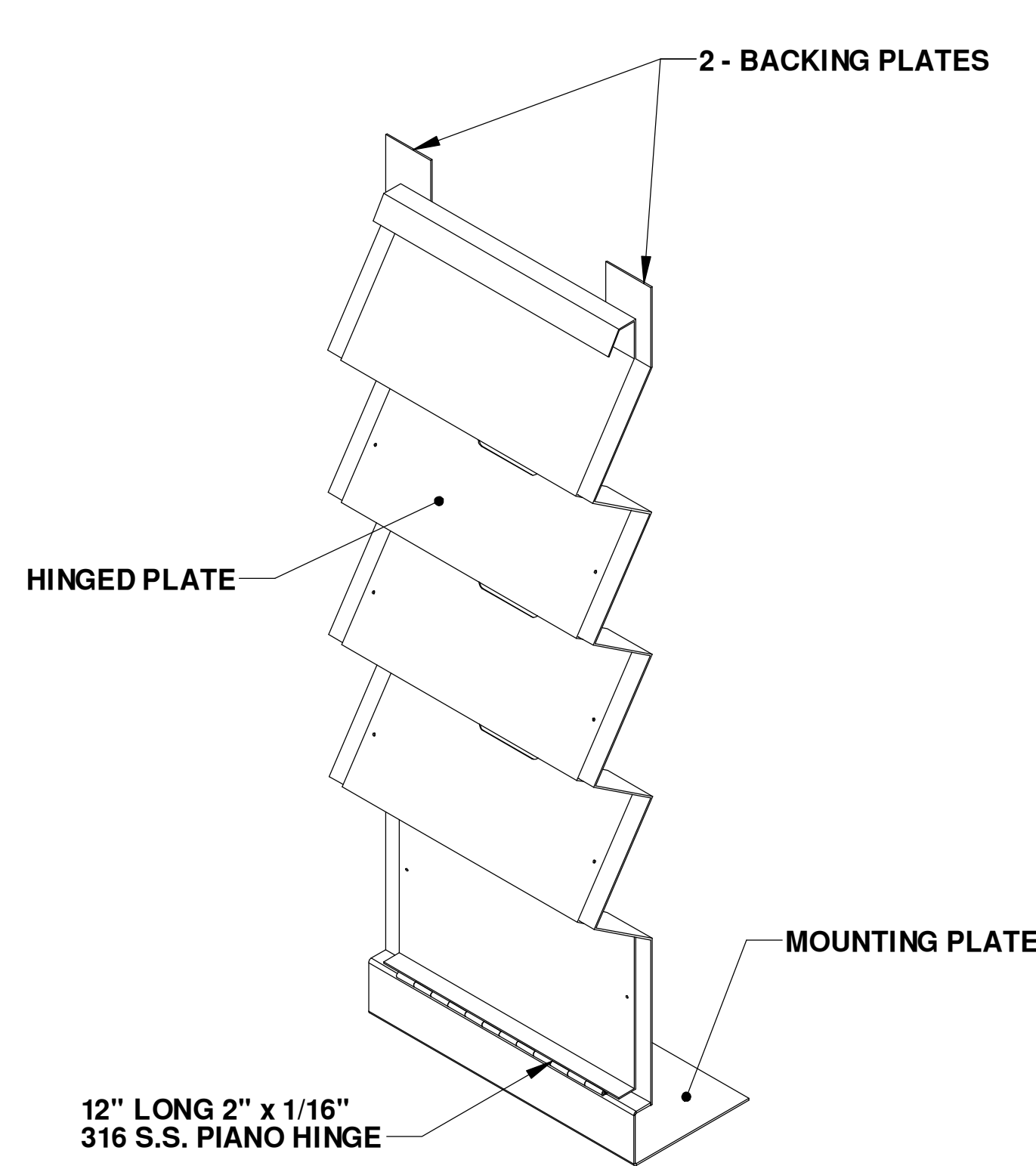

**HINGE PLATE ASSEMBLY**

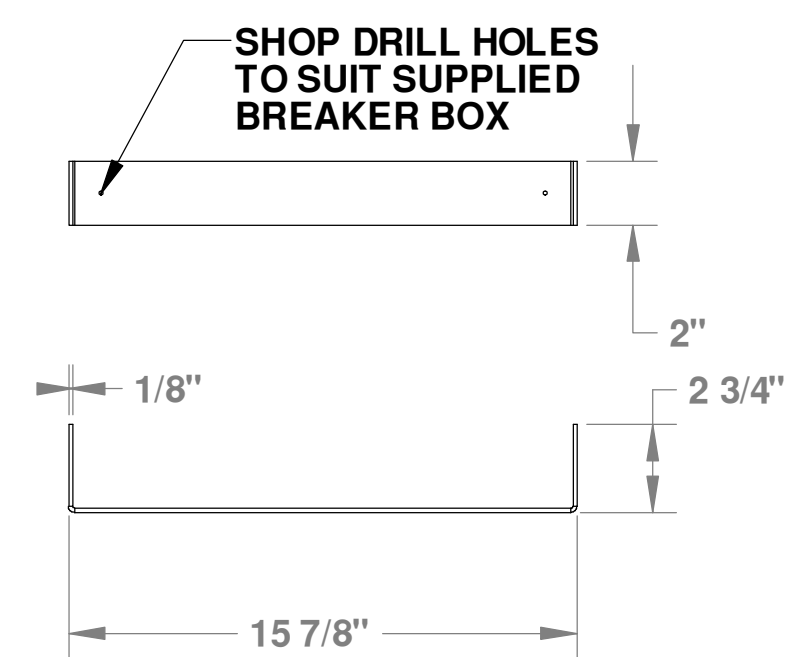

**BREAKER BOX MOUNT**  
 MATERIAL: 1/8" ALUMINUM PLATE  
 2 REQUIRED  
 1/2" = 1'-0"

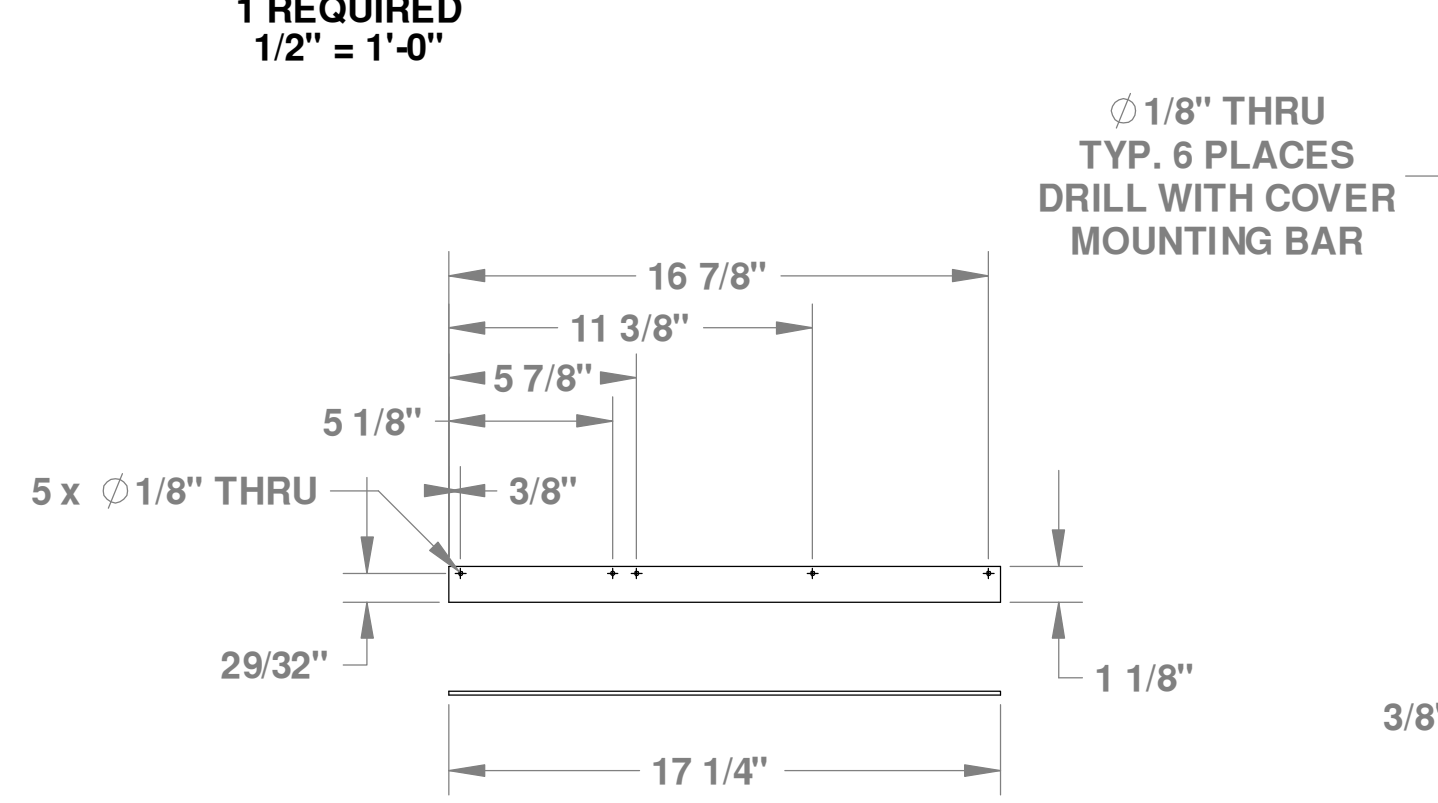

**COVER MOUNTING BARS**  
 MATERIAL: 1/8" ALUMINUM PLATE  
 2 REQUIRED  
 1/2" = 1'-0"

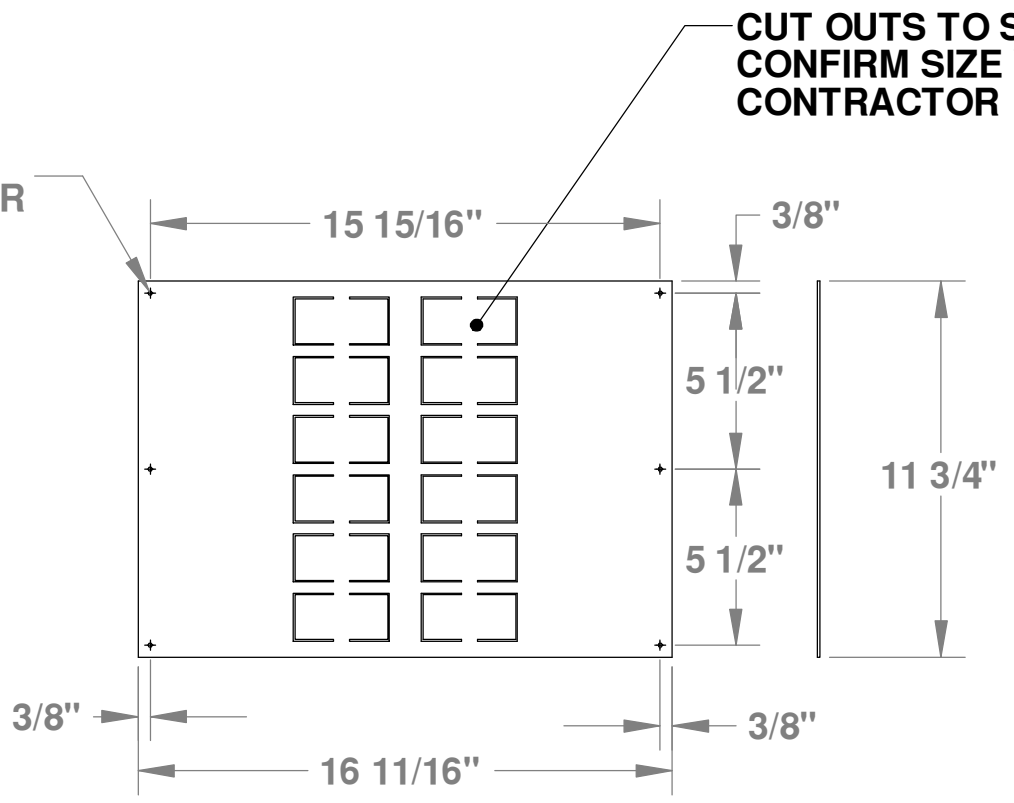

**PANEL COVER**  
 MATERIAL: 12 GAUGE ALUMINUM  
 1 REQUIRED  
 1/2" = 1'-0"

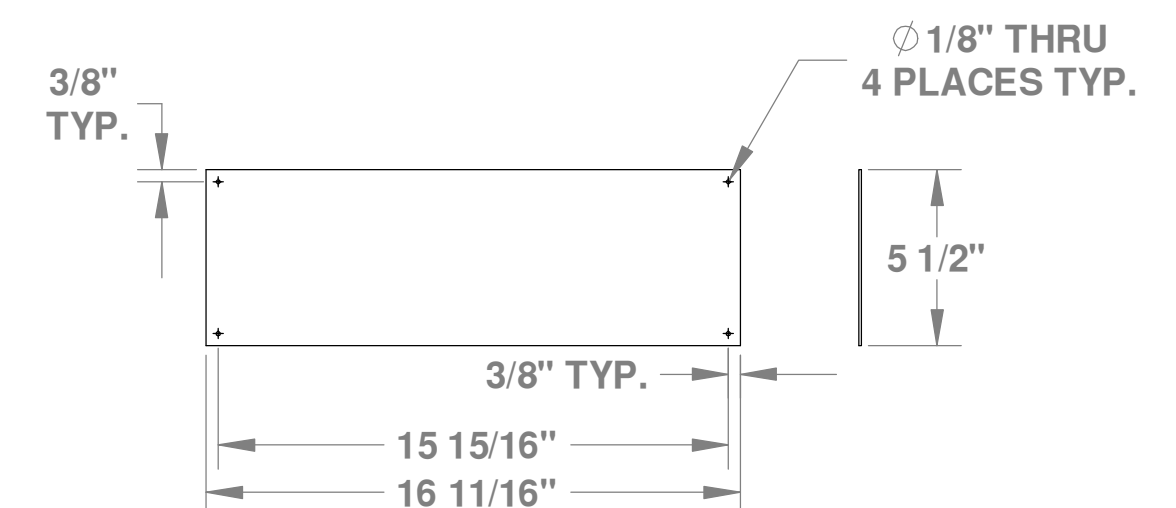

**COVER PLATE**  
 MATERIAL: 12 GAUGE ALUMINUM  
 1 REQUIRED  
 1/2" = 1'-0"



**PANEL ASSEMBLY**

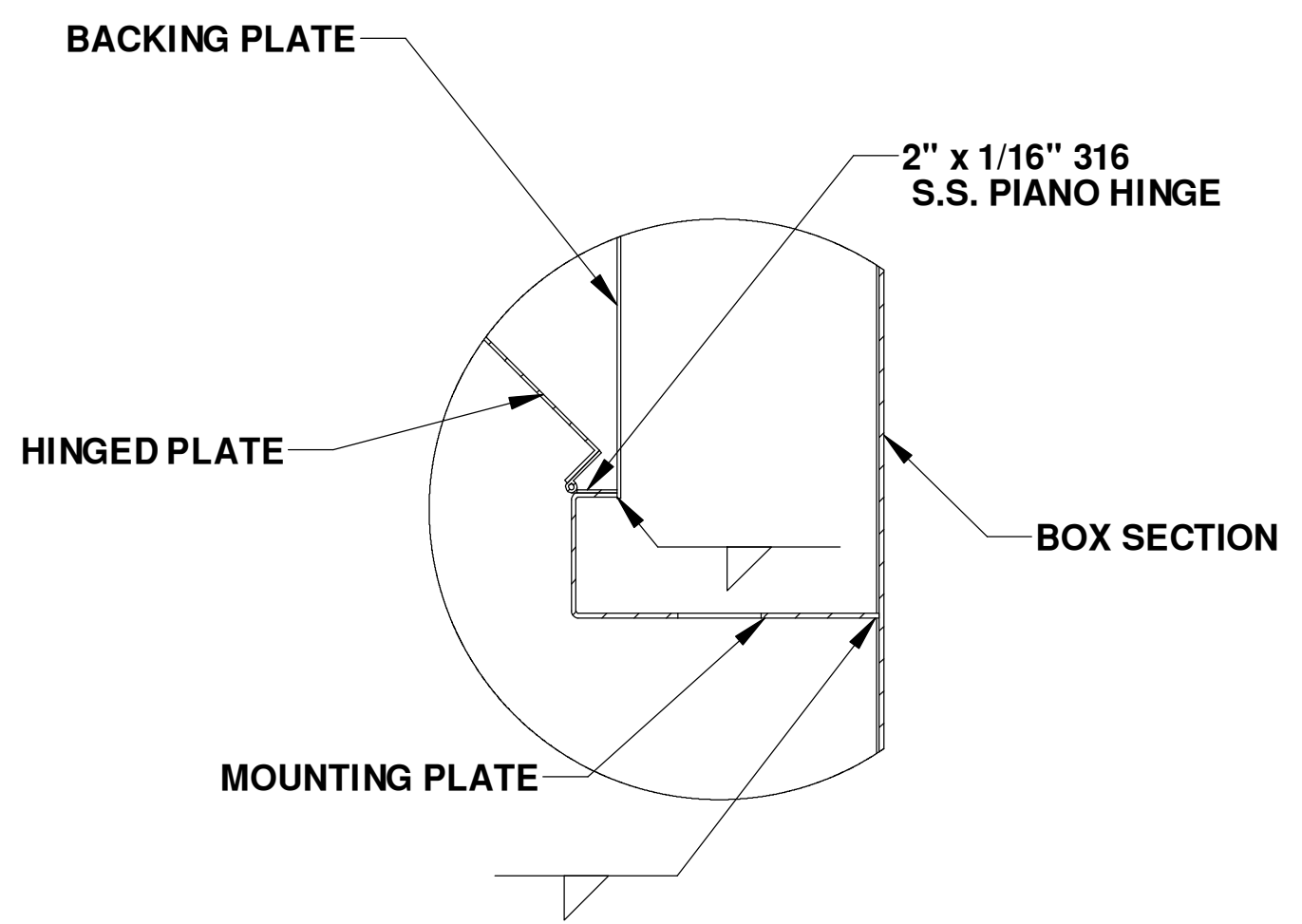

**HINGE DETAIL**

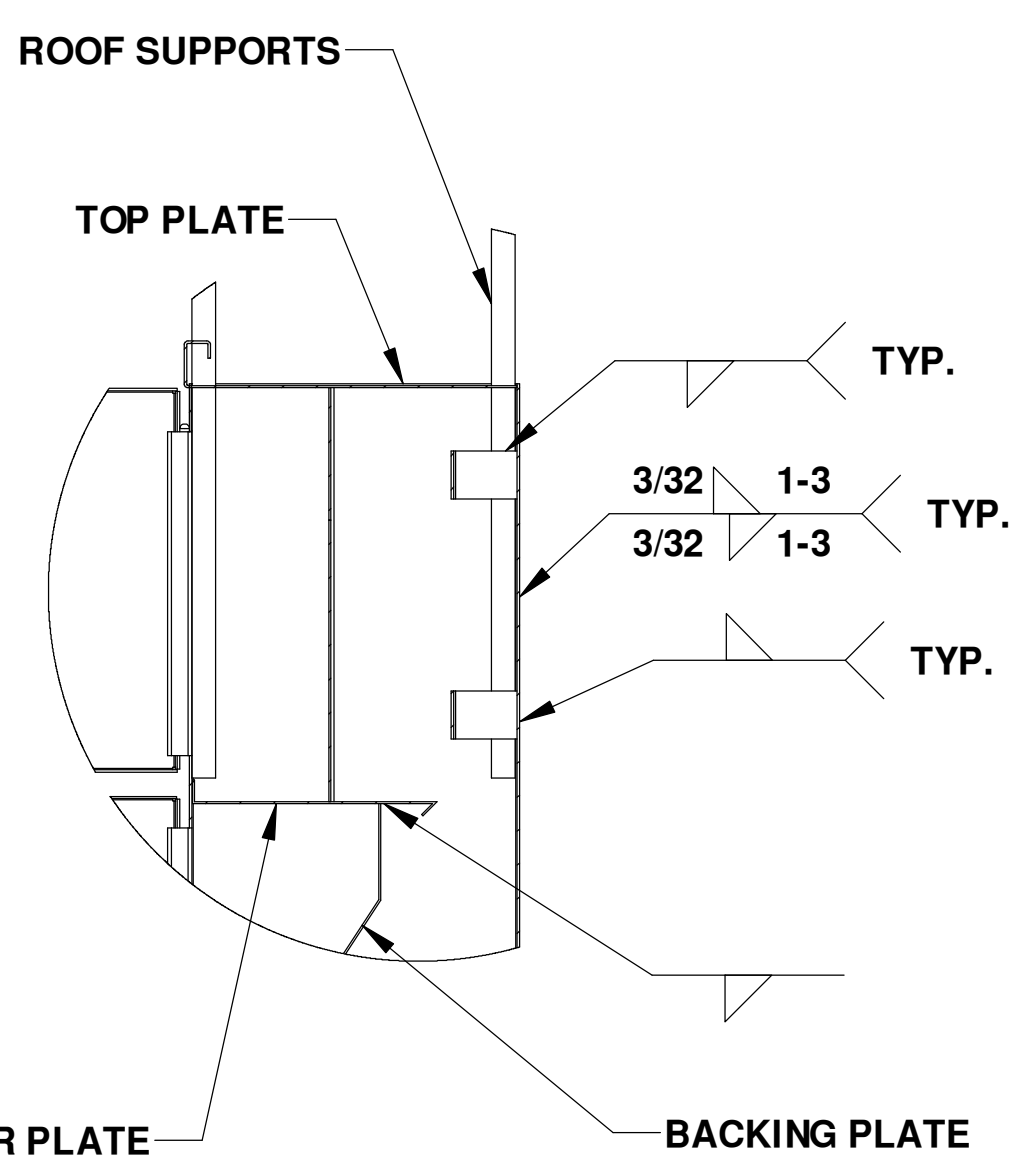
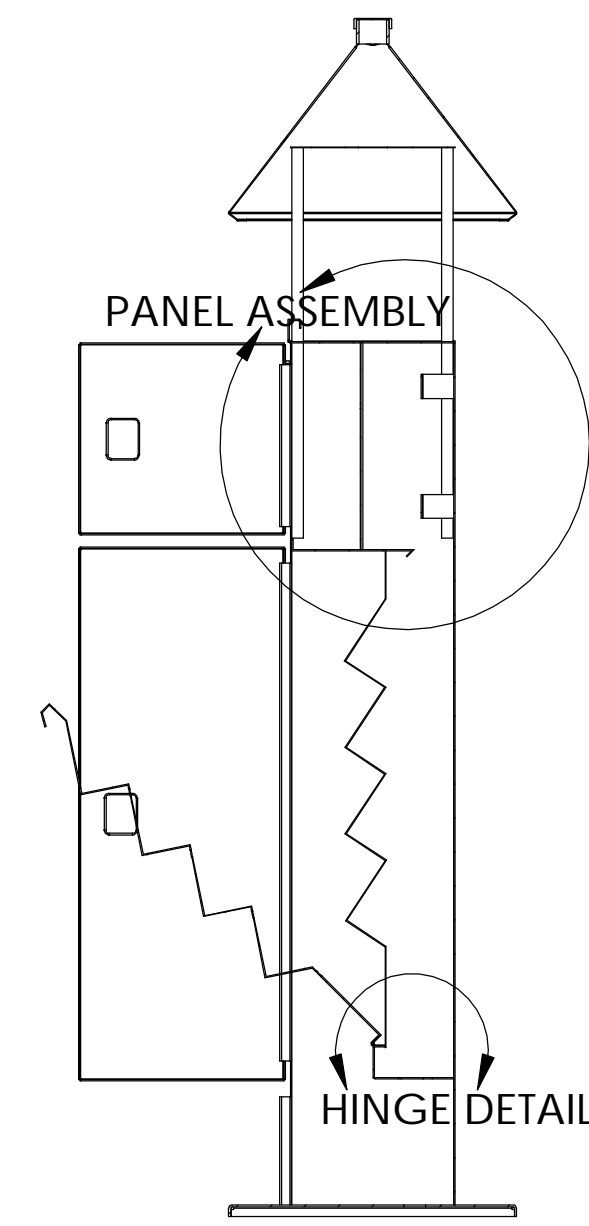

**PANEL ASSEMBLY**

UNLESS OTHERWISE SPECIFIED:	DATE	NAME
DIMENSIONS ARE IN INCHES		WSL
TOLERANCES:		PL
FRACTIONAL ±		MB
ANGULAR MATCH ±		
TWO PLACE DECIMAL ±		
THREE PLACE DECIMAL ±		
INTERPRET GEOMETRIC TOLERANCING PER:		
MATERIAL		
FINISH		
DO NOT SCALE DRAWING		



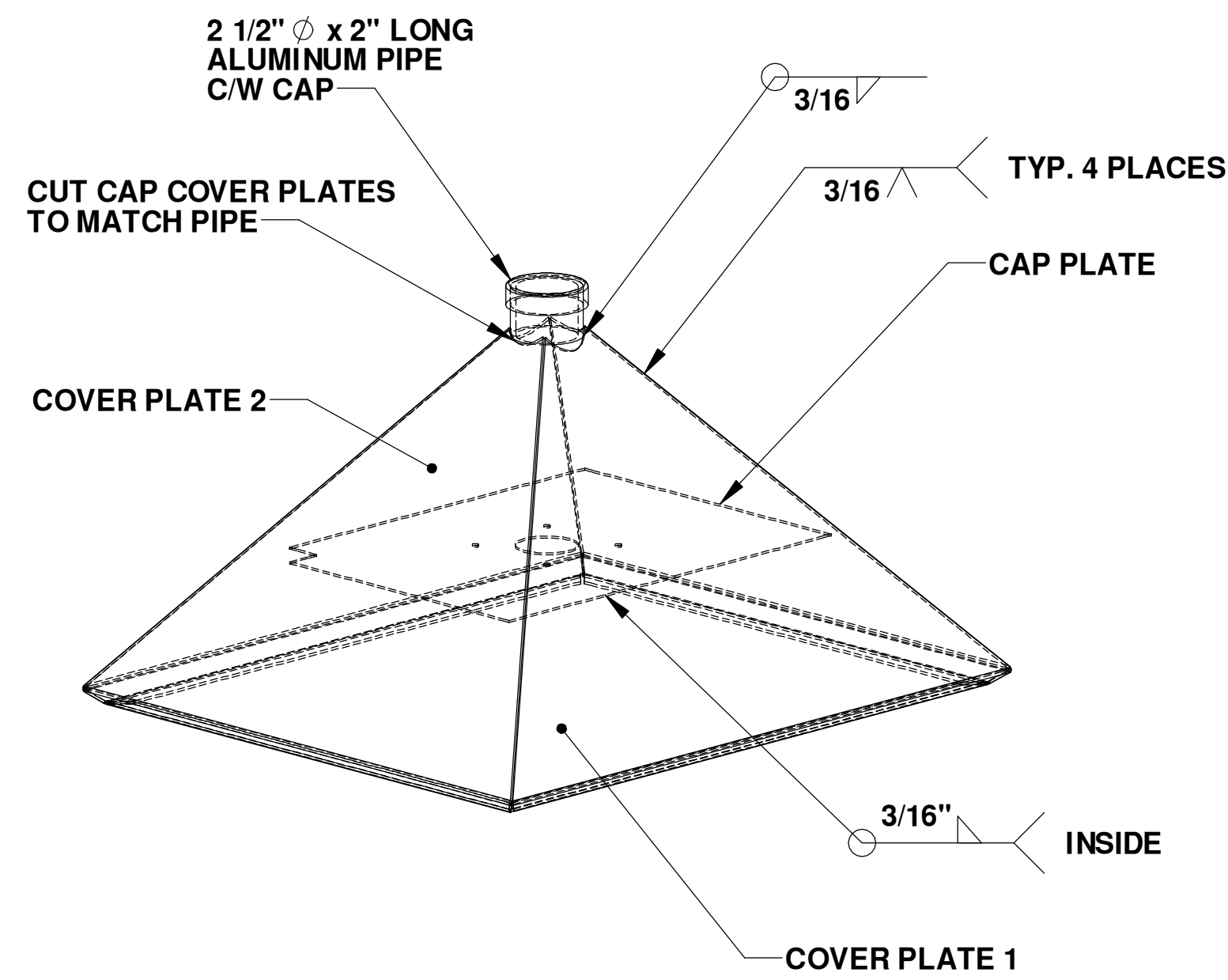

**ROOF CAP ASSEMBLY**

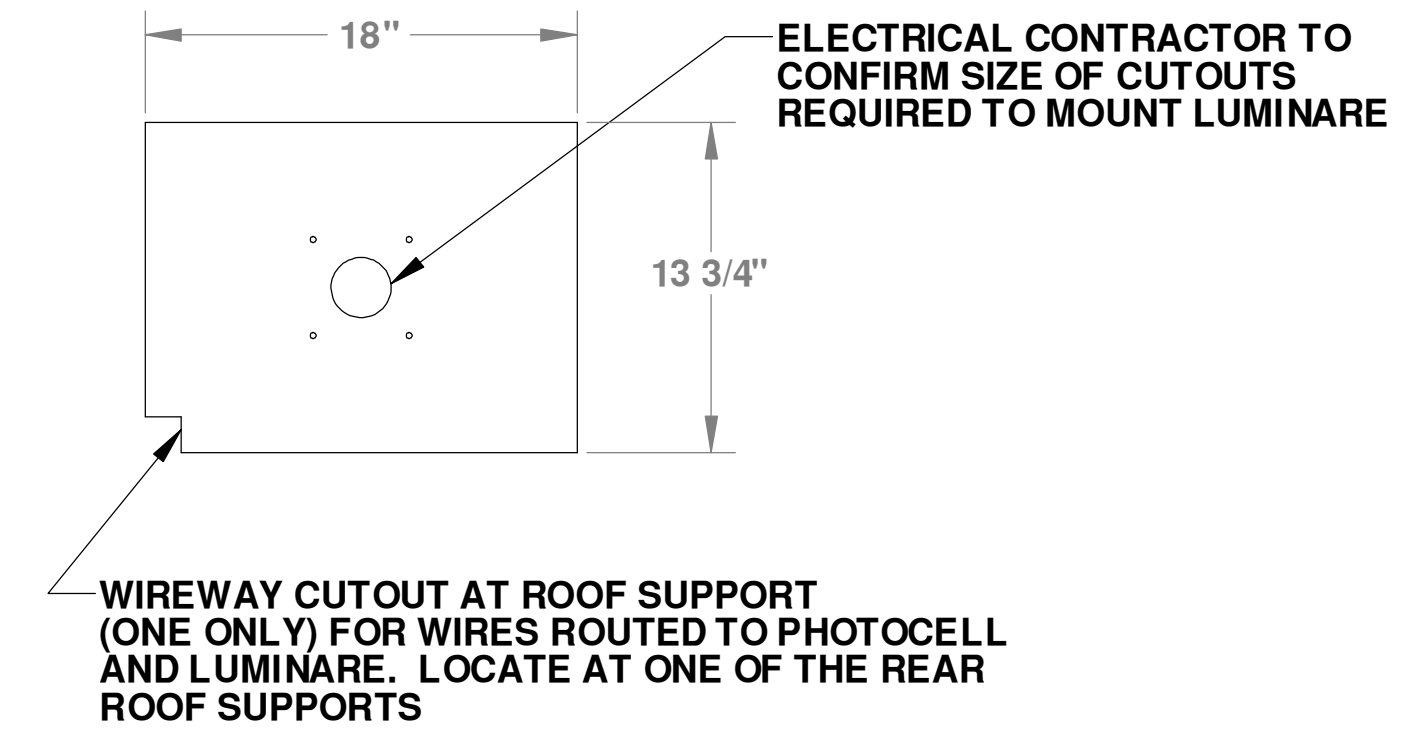
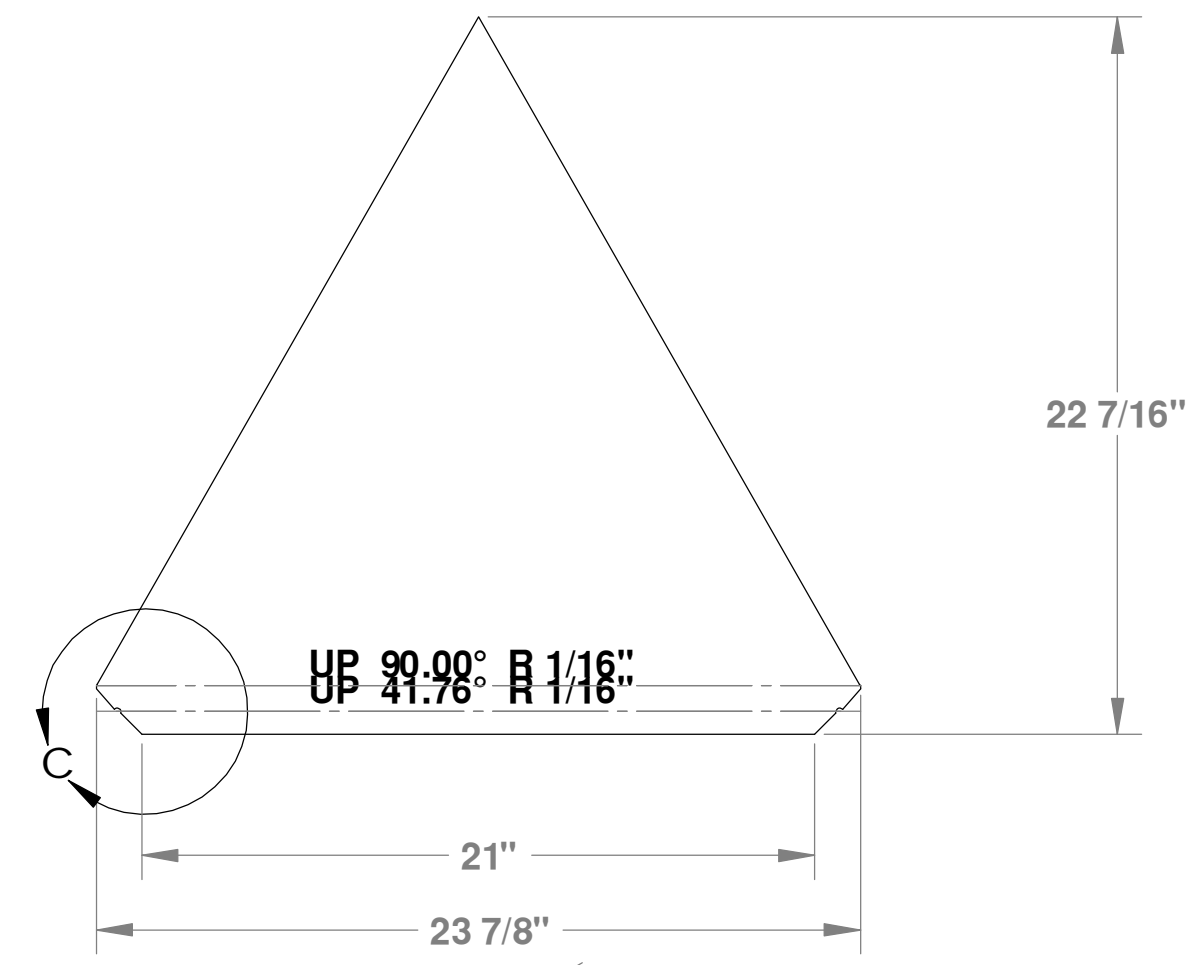
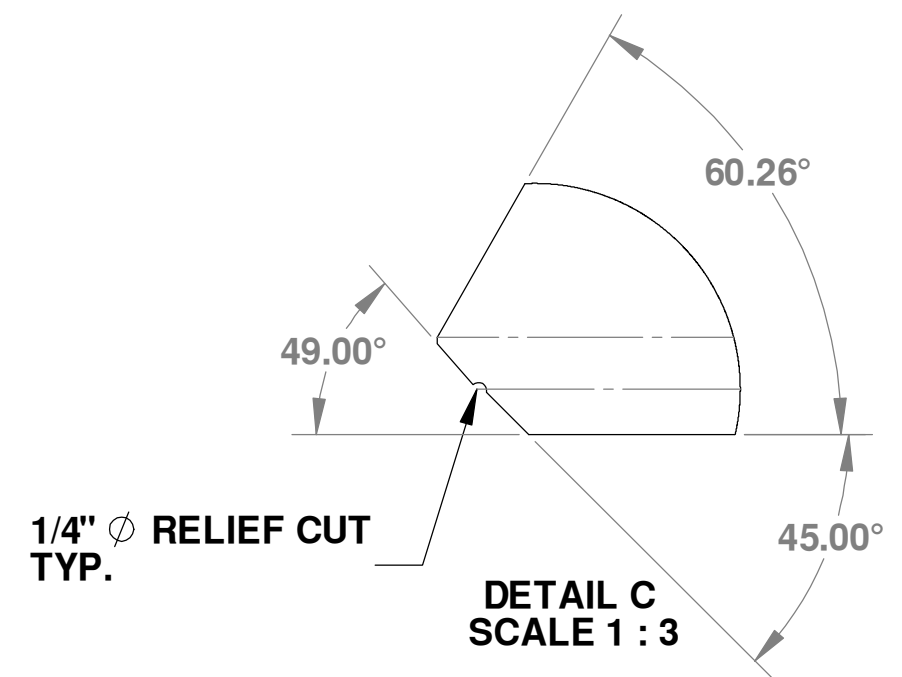

**CAP PLATE**  
 MATERIAL: 12 GAUGE ALUMINUM  
 1 REQUIRED  
 3/4" = 1'-0"

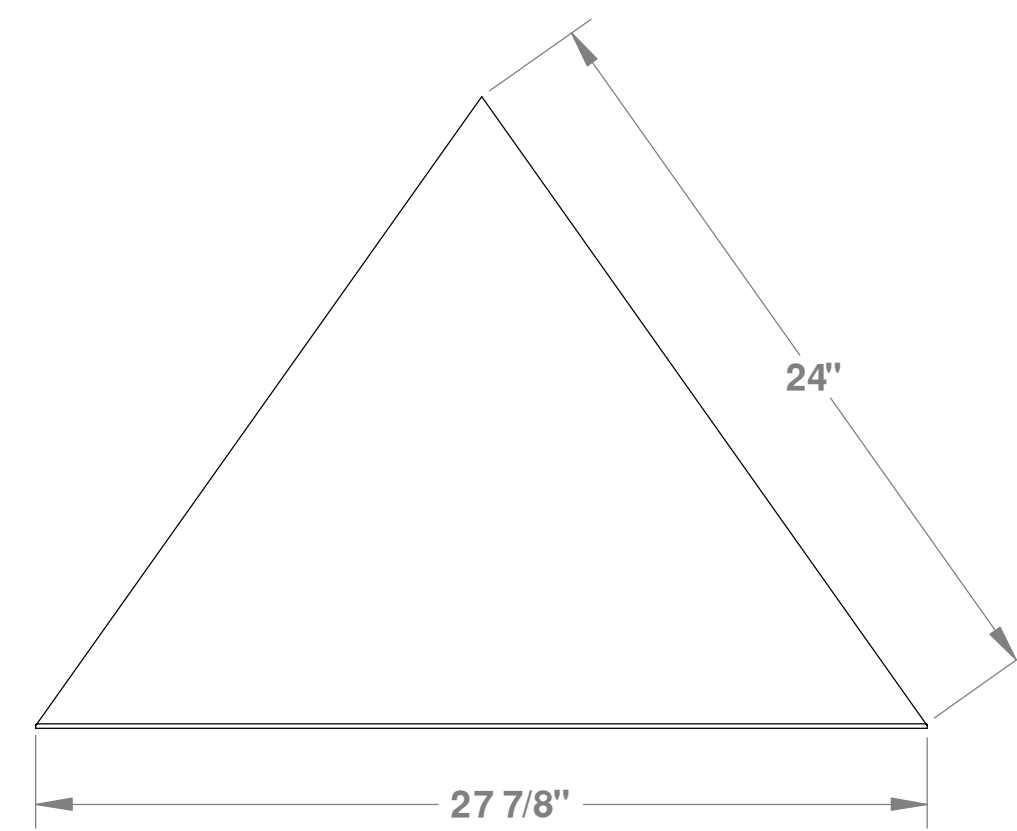
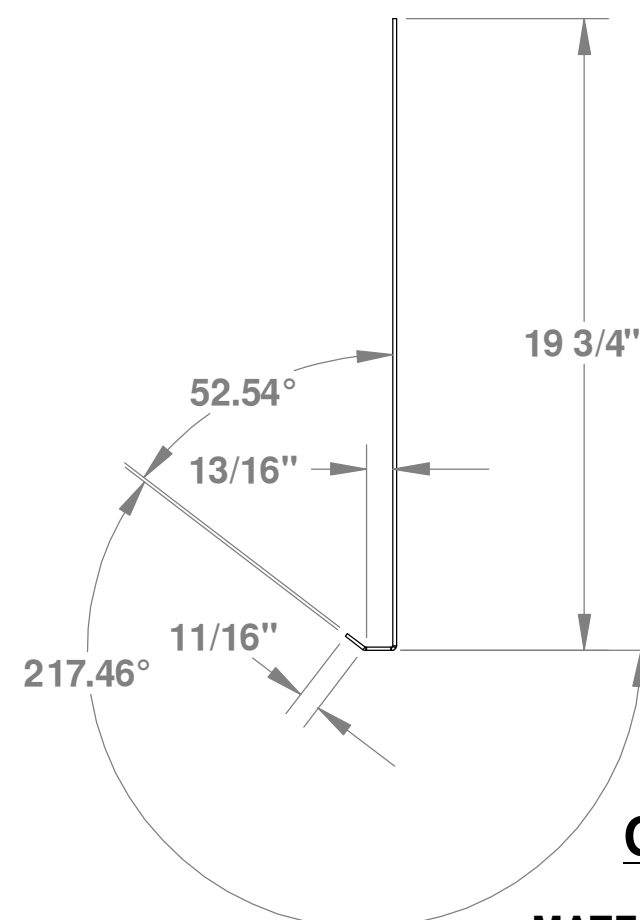
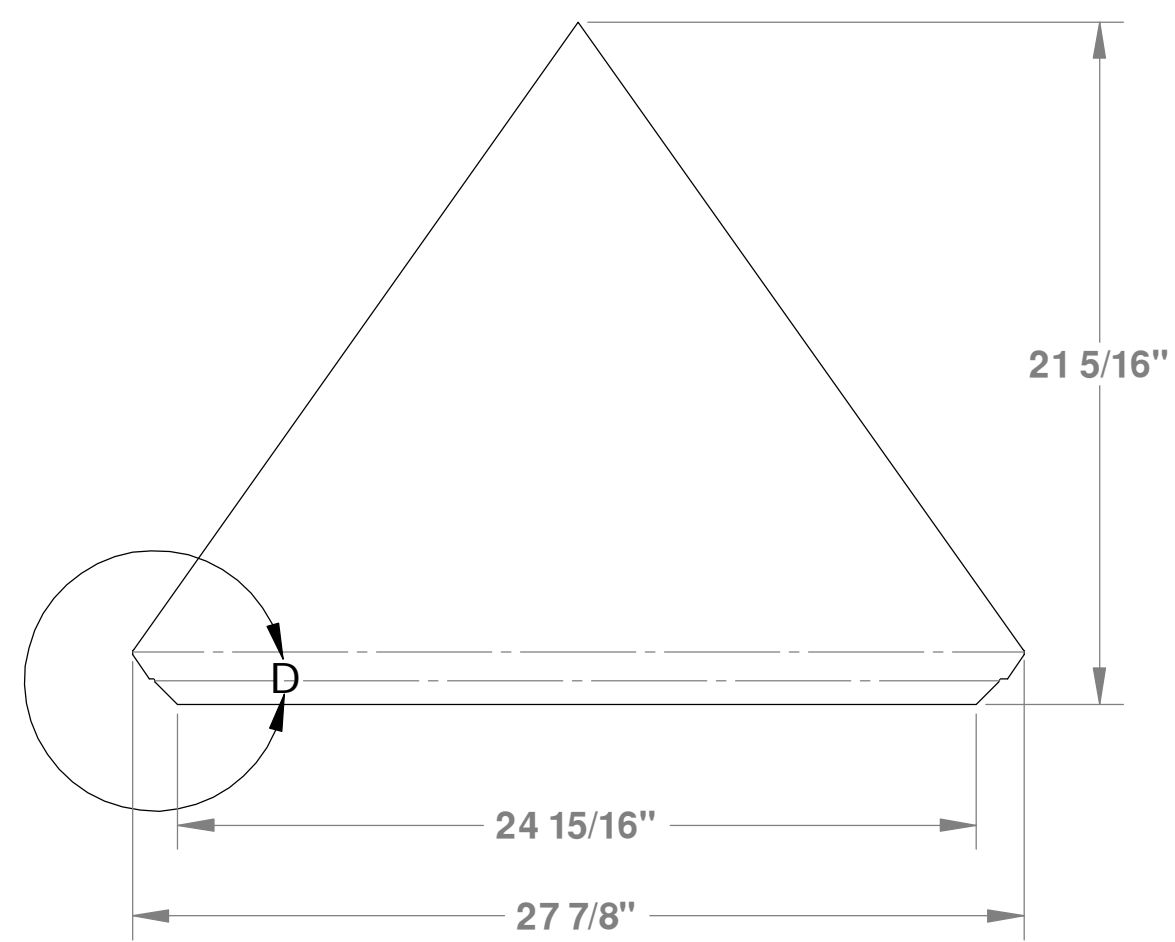
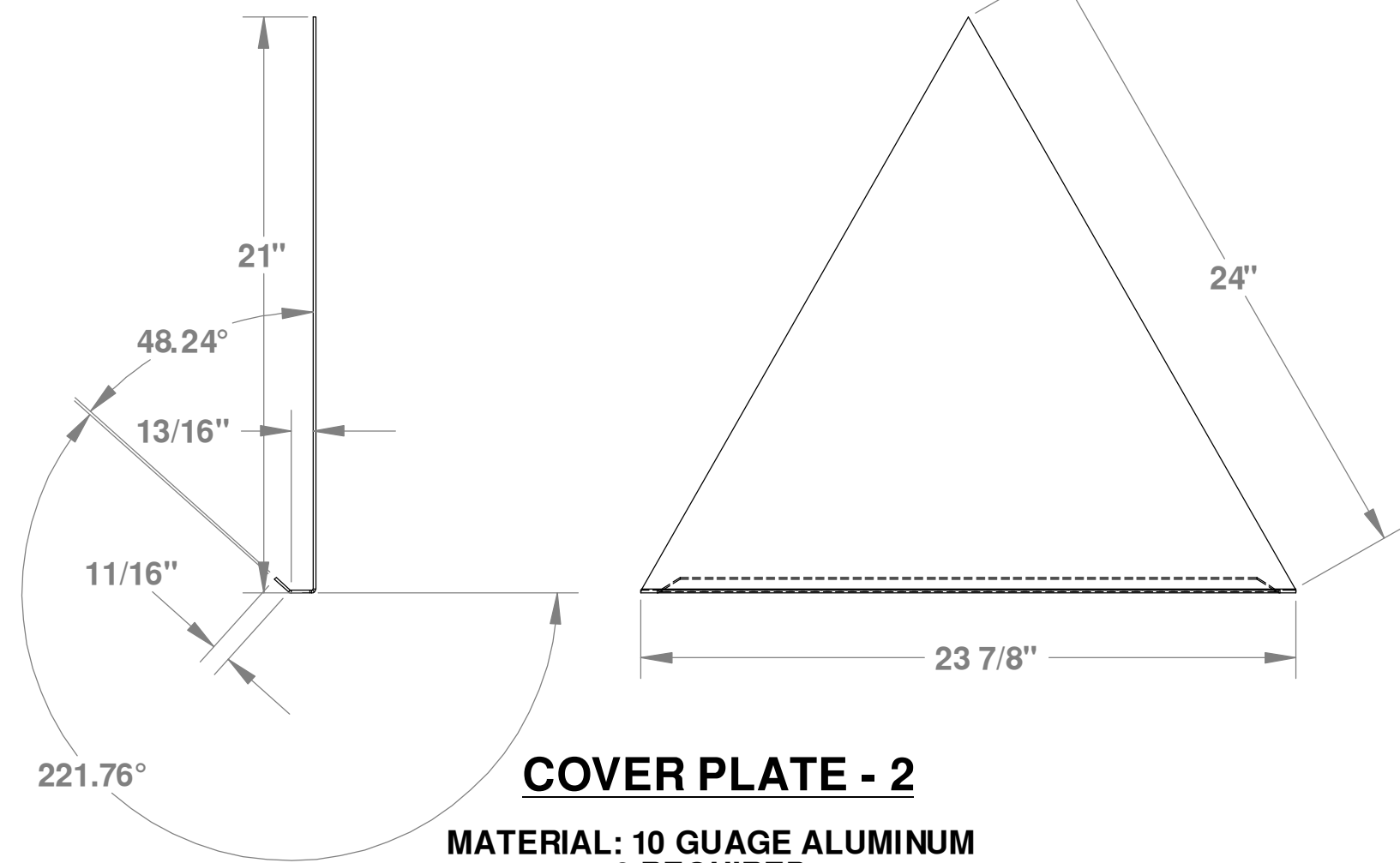

**COVER PLATE - 1**  
 MATERIAL: 10 GAUGE ALUMINUM  
 2 REQUIRED  
 1/2" = 1'-0"

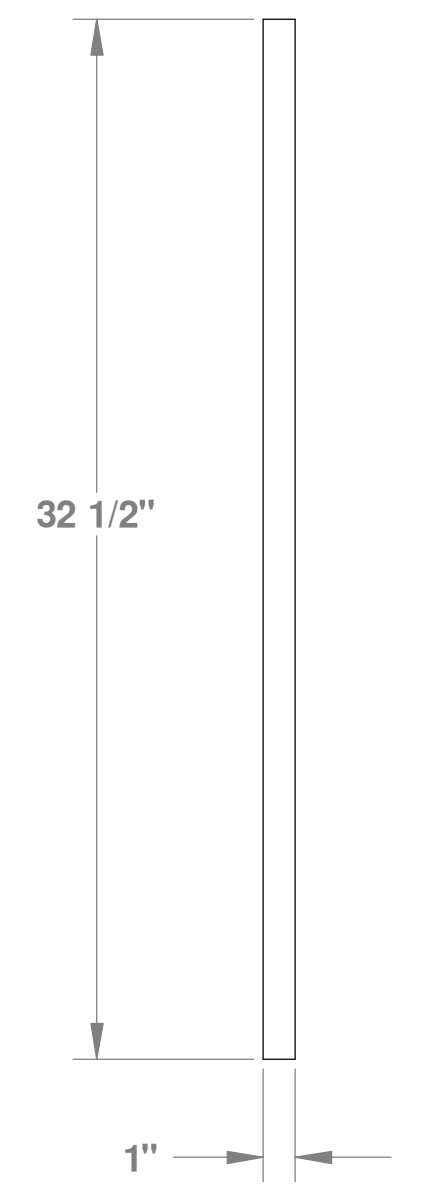
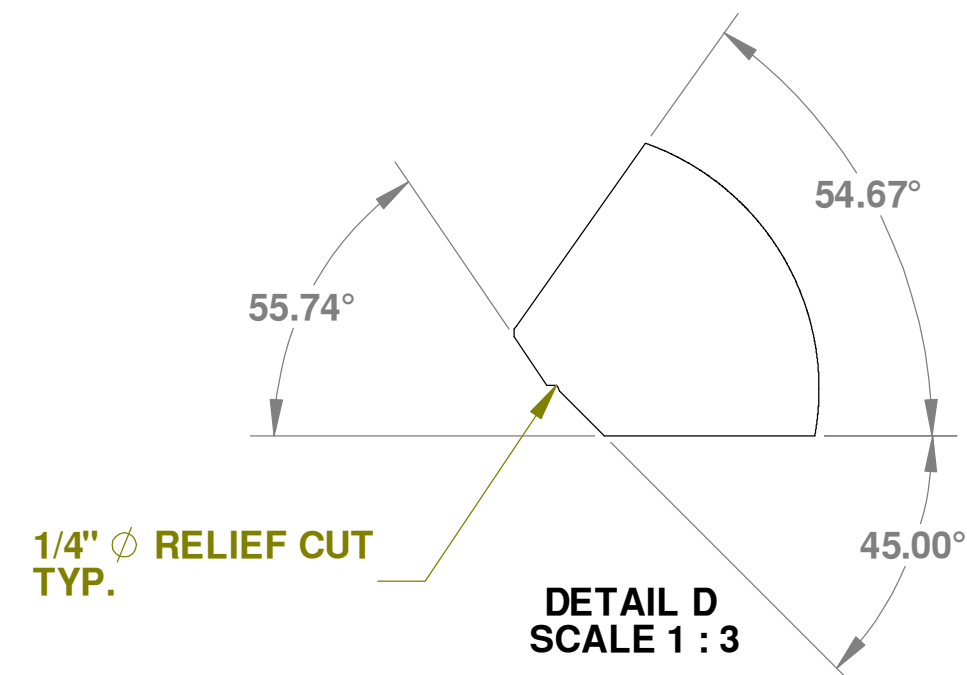

**ROOF SUPPORTS**  
 MATERIAL: TS 1 x 1 x 0.12 x 32 1/2" LONG  
 4 REQUIRED  
 1/2" = 1'-0"

UNLESS OTHERWISE SPECIFIED:		DATE	NAME
DIMENSIONS ARE IN INCHES			WSL
TOLERANCES:			PL
FRACTIONAL ±			MB
ANGULAR MATCH ±			
TWO PLACE DECIMAL ±			
THREE PLACE DECIMAL ±			
INTERPRET GEOMETRIC TOLERANCING PER:		COMMENTS:	
MATERIAL: --			
NEXT ASSY: --			
USED ON: --			
FINISH: --			
APPLICATION: --			
DO NOT SCALE DRAWING			