



Royal Canadian Mounted Police
Gendarmerie Royale du Canada

Doc. no: G.S. 1045-350
Date: 2015-07-28

Specification

Carrier, Plate, Rifle

This document has 23 pages including the drawings.

This document was created in English.

The document is available in English and French.

English/Anglais
Français/French

The photograph on this page is for reference only.



RCMP VIEWING SAMPLE

A viewing sample, when available, will be supplied to the successful bidder.

This will be used for the guidance of the manufacturer in all factors not covered by this specification or referred to therein. Variation from the specification may appear in the sample in which case the specification shall govern.

It may be obtained from:

Royal Canadian Mounted Police
ATTN: Uniform and Equipment Program
(440 Coventry Road, Warehouse Building)
1200 Vanier Parkway
Ottawa, Ontario
K1A 0R2

It will be sent “prepaid” and is to be returned “prepaid”.

The viewing sample shall be returned to the RCMP in the same condition as received by the manufacturer. Lost or damaged viewing samples shall be replaced by an identical item or the RCMP shall be reimbursed for the cost of an acceptable replacement.

SPECIFICATION

CARRIER, PLATE, RIFLE

1. Definitions

- 1.1 This specification shall govern the manufacture and inspection of Carrier, Plate, Rifle. The specific items covered under this specification with stock numbers are as follows:
- i. 122032 – Carrier, Plate, Rifle with Molle/ Gilet pare-balles avec sangles « Molle »
 - ii. 123169 – Carrier, Plate, Rifle, Blank Patch/ Pièce unie pour gilet pare-balles
- 1.2 This specification, drawing, viewing sample, or other information issued in connection therewith, may only be used for specific enquiries, solicitations, or orders placed on behalf of the Royal Canadian Mounted Police.
- 1.3 This specification supersedes all previous specifications for Carrier, Plate, Rifle.
- 1.4 This specification has been translated into French from this original English language document.

2. Applicable Specifications

- 2.1 The following publications are applicable to this specification and to the issues in effect on the date of the solicitation, unless otherwise specified.
- 2.2 CAN/CGSB 4.2 Textile Test Methods.
- 2.3 FED-STD 191, Federal Standard, Textile Test Methods.
- 2.4 Federal Standard A-A-59826, Thread, Nylon.
- 2.5 ASTM, American Society for Testing and Materials, Method D3776/D3776M-09a (2013), D5169-98 (2015) and D5170-98 (2015).
- 2.6 ISO 105, ISO 7211-2, ISO 4920 International Standards Organization.

3. **General Requirements**

3.1 The article or material covered by this specification shall be free from imperfections or blemishes such as may affect its appearance or serviceability. In all particulars not covered by this specification or contract documents, production shall be equivalent in all respects to the viewing sample.

3.2 **Design**

3.2.1 **Carrier, Plate, Rifle** – The Carrier, Plate, Rifle shall have two pouches made of nylon fabric material, with a side buckle opening, and adjustable shoulder and elasticized waist straps. It shall be available in one size only. It shall have an accessory pouch attachment webbing system on the front panel only. There shall be removable padded shoulder pads, slid onto the front shoulder straps to protect the shoulders from the buckles. There shall be POLICE markings direct embroidered on the front and back pouches. The Carrier, Plate, Rifle shall be manufactured in accordance with the attached drawings, forming part of this specification and the viewing sample.

3.2.2 **Carrier, Plate, Rifle, Blank Patch** – The blank patch for covering the Police identification is a separate item and ordered independently from the Carrier, Plate, Rifle. This patch shall be manufactured in accordance with the attached drawings, forming part of this specification and the viewing sample.

4. **Detail Requirements**

4.1 **Components**

4.1.1 **Shell Material** – The shell material shall be a dark navy, 100% nylon, 1000 denier fabric meeting the requirements outlined in Table I.

4.1.2 **Lining Material, Spacer Mesh** – The lining material shall be a 100% Polyester spacer mesh with a mass of $275 \text{ g/m}^2 \pm 14 \text{ g/m}^2$ finished with a wicking and anti-microbial treatment and thickness of $2 \text{ mm} \pm 0.5 \text{ mm}$. It shall be black in colour.

4.1.3 **Hook and Loop Tape** – The hook and loop tape shall be woven nylon, black in colour, with a high life cycle. The combined hook and loop shall have no less than 8 P.S.I length-wise shear strength with initial peel strength of not less than 1 P.I.W. when tested to ASTM D5169-98 (2015), standard test method for shear strength [dynamic method] of hook and loop touch fasteners and ASTM D5170-

98 (2015), standard test method for peel strength ["T" method] of hook and loop touch fasteners." Dimensions shall be as per drawings.

- 4.1.4 **Elastic** - The elastic shall be heavy duty nylon, black in colour, with maximum elongation of 130% and recovery as per viewing sample. It shall be woven type with stretch only in the length and black in colour. Dimensions shall be in accordance with the drawings.
- 4.1.5 **Nylon Webbing**
- 4.1.5.1 **Nylon Webbing, Shoulder and Waist Strap** - The webbing shall be a durable nylon webbing, luggage quality, black in colour measuring 3.8 cm (1.5") wide and 0.043" \pm 0.01" thick. It shall have a minimum tensile strength of 1500 lbs. as per Federal Standard 191-5206 test method #4108 and be equal in appearance to the viewing sample. Tape Craft #N0015S is known to meet the requirements.
- 4.1.5.2 **Nylon Webbing, Accessory Attachment** - The webbing shall be a durable nylon webbing, luggage quality, black in colour measuring 2.54 cm (1") wide and 0.04" \pm 0.01" thick. It shall have a minimum tensile strength of 1000 lbs. as per Federal Standard 191-5206 test method #4108 and be equal in appearance to the viewing sample. Tape Craft #N0015-1"-YD001-352 is known to meet the requirements.
- 4.1.6 **Buckles and Hardware**
- 4.1.6.1 **Side Release Buckles** – The buckle shall be a plastic two piece (male and female), made of high quality impact resistant nylon black in colour 3.8 cm (1½") wide, equal to viewing sample. The male portion shall be with a dual adjust system. National Molding Product 6584/6585 is known to meet this requirement.
- 4.1.6.2 **Tensionlock Buckle** – The tensionlock buckle shall be plastic, made of high quality impact resistant nylon, black in colour 3.8 cm (1½") wide, equal to viewing sample. National Molding Product 5852 is known to meet this requirement.
- 4.1.6.3 **Sliplock Buckle** – The sliplock buckle shall be plastic, made of high quality impact resistant nylon, black in colour 3.8 cm (1½") wide, equal to viewing sample. National Molding Product 5058 is known to meet this requirement.

- 4.1.7 **Thread** - The thread shall be twisted multifilaments bonded nylon, Type II, Class A, size F (Tex 90), in accordance with U.S. government standard A-A-59826, black in colour.
- 4.1.8 **Plastic Reinforcement Stiffener** – The reinforcement stiffener shall be plastic, 1.45-1.60 mm thick, equal to viewing sample.
- 4.1.9 **Grosgrain** - Shall be heavy duty nylon grosgrain binding tape, black in colour 2 cm wide, 0.3 mm thickness, and be equal in all respects to viewing sample.
- 4.1.10 **Neoprene Padding** – The neoprene padding shall be made of 100% Nylon on the outer surface and 10% Nylon/ 90% Neoprene as the inner content. It shall be 725 g/m² ± 25g/m², 2.5 mm thick, black in colour and be equal in all respects to viewing sample.
- 4.2 **Size and Dimensions** – The Carrier, Plate, Rifle to this specification shall be supplied in one size to the dimensions given in the scale of measurements and drawings forming part of this specification.
- 4.3 **Construction**
- 4.3.1 **Stitching** - All stitching shall be lockstitch. There shall be not less than three or more than four stitches per centimetre. The beginning and ending of all stitching shall be securely backstitch tacked, unless secured by other stitching. All topstitching as indicated in the drawings and on the sample shall be sewn using a 2 mm gauge.
- 4.3.2 **Plate Pouches** - The Rifle Plate Carrier consists of two rifle plate pouches, front and back, each intended to carry a rifle plate of up to 4 kg in weight. The pouches shall easily accommodate an RCMP rifle plate measuring up to 3.3 cm thick.
- 4.3.2.1 **Front Plate Pouch** – All pieces of the pouch shall be made with material as specified in Para. 4.1.1. There shall be loop tape, as specified in Para. 4.1.3, placed on top of the shell material on the front of the pouch. The word “POLICE” shall be embroidered directly onto the loop tape. The font shall be Arial Bold, uppercase letters in white and shall be dimensioned as per drawing # 6. The top edge of the Police lettering shall start at 2 cm ± 0.2 cm from the top edge of the loop tape and shall be centered across the front. There shall be four horizontal rows of the webbing as specified in Para. 4.1.5.2 sewn to the front of the pouch. The first row shall start 8 cm ± 0.5 cm from the top edge of the loop

tape. Each subsequent row shall be spaced 2.5 cm apart. Each row of webbing shall be bar tacked 5 times at 3.8 cm intervals beginning 6 cm from the front side seam as outlined in drawing #2. The bar tack shall penetrate through all layers and measure 2.5 cm in length. The back of the pouch shall have a piece of loop tape, as specified in Para. 4.1.3, measuring 3.8 cm wide, applied to the face material at the opening. This opening shall measure 20.5 cm \pm 0.5 cm. Refer to drawing #4. The side piece shall measure 7.5 cm wide at the top edge of each end gradually decreasing to 3.2 cm wide \pm 0.5 cm, starting at 9.5 cm from each end. The side piece ends shall have a piece of material as specified in Para. 4.1.9, folded in half and sewn over the raw edge. An adjustable waist strap component, as constructed in Para. 4.3.4, shall be inserted in the seam between the front pouch and the side piece, centered with the bottom row of webbing. The side piece shall be sewn to join the front and the rear pouch at the sides and bottom. The top cover consisting of three pieces shall be sewn along the top side and top front to enclose the plate. A piece of hook tape, as specified in Para. 4.1.3, measuring 3.8 cm wide by the length of the opening from seam to seam, shall be sewn on the back side of the material butted against the outer edge. The adjustable shoulder strap as specified in Para. 4.3.3 shall be inserted into the flap side piece on each side, stitched and bar tacked the length of the opening. The shoulder strap shall be angled away from the neck. The two straps shall be inserted into the right and left sides of the front pouch with the loop tape end inserted to the pouch and facing outward. The front plate pouch shall be shaped, dimensioned and constructed in accordance with drawing #2 and the viewing sample.

- 4.3.2.2 **Back Plate Pouch** - All pieces of the pouch shall be made with material as specified in Para. 4.1.1. The front shall be constructed from two pieces with a flap inserted in the seam. There shall be loop tape as specified in paragraph 4.1.3 measuring 7 cm wide sewn to the front of the pouch at the top, and secured into the side seams. The word "POLICE" shall be embroidered directly onto the loop tape. The font shall be Arial Bold, uppercase letters in white and shall be dimensioned as per drawing # 6. The top edge of the Police lettering shall start at 1.5 cm \pm 0.2 cm from the top edge of the loop tape and shall be centered across the front of the back pouch. There shall be a horizontal seam 18.5 cm \pm 0.5 cm below the top edge of the loop tape to secure a flap. The top side of the seam shall be topstitched with 3 mm gauge. The flap shall be constructed using two layers of shell material as specified in Para. 4.1.1 and a middle layer of stiffener as specified in Para. 4.1.8. The flap shall measure 24 cm x 9 cm \pm 0.5 cm. A piece of loop tape measuring 7.5 cm wide by 22 cm \pm 0.5 cm long shall be sewn to the underside of the flap facing towards the front of the pouch. Loop tape as specified in paragraph 4.1.3, measuring 7.5 cm wide by 22 cm \pm 0.5 cm long shall

be sewn onto the front of the pouch, 0.5 cm below the flap seam. The back of the pouch shall have a piece of loop tape, as specified in Para. 4.1.3, measuring 3.8 cm wide, applied to the face material at the opening. This opening shall measure 20.5 cm \pm 0.5 cm. Refer to drawing #4. The side piece shall measure 7.5 cm wide the top edge of each end gradually decreasing to 3.2 cm wide \pm 0.5 cm, starting at 9.5 cm from each end. The side piece ends shall have a piece of material as specified in Para. 4.1.9, folded in half and sewn over the raw edge. The side piece shall be sewn to join the front and the rear pouch at the sides and bottom. The top cover consisting of three pieces shall be sewn along the top side and top front to enclose the plate. A piece of hook tape, as specified in Para. 4.1.3, measuring 3.8 cm wide by the length of the opening from seam to seam, shall be sewn on the back side of the material butted against the outer edge. The adjustable shoulder strap as specified in Para. 4.3.3 shall be inserted into the flap side piece on each side, stitched and bar tacked the length of the opening. The shoulder strap shall be angled away from the neck. An adjustable waist strap, as specified in Para. 4.3.4, shall be attached between the loop tape and flap. The back pouch shall be shaped, dimensioned and constructed in accordance with drawing #3 and the viewing sample.

- 4.3.3 **Adjustable Shoulder Straps** – There are four separate pieces that make up the adjustable shoulder straps. Each strap is made using different components. The adjustable shoulder strap piece sewn to the front pouch shall be made with the webbing as specified in Para. 4.1.5.1 and shall measure 3.8 cm wide x 37 cm long. There shall be loop tape as specified in Para. 4.1.3, measuring 3.8 cm x 15 cm sewn to the front of the webbing at one end. There shall be hook tape as specified in Para. 4.1.3, measuring 3.8 cm x 10 cm sewn to the front of the webbing at the opposite end. The two straps shall be inserted into the right and left sides of the front pouch with the hook tape facing outwards. The male portion of a side release buckle, specified in Para. 4.1.6.1, shall feed through the left shoulder strap with the hook tape folding back onto the corresponding loop tape as per drawing #2. The female portion of the side release buckle as specified in Para. 4.1.6.1, shall be permanently sewn to the shoulder strap webbing measuring 3.8 cm x 10.5 cm \pm 0.5 cm and shall be inserted on the left side of the back plate pouch as per drawing #3. The tensionlock sliding buckle, as specified in Para. 4.1.6.2, shall be permanently sewn to the shoulder strap webbing measuring 3.8 cm x 14 cm \pm 0.5 cm and shall be inserted on the right side of the back plate pouch as per drawing #3. The right front shoulder strap should be fed through the tensionlock buckle to close the shoulder strap. A bar tack the full width of the strap shall be used to secure the straps to the pouch material and to secure the side release and tensionlock sliding buckles to the back shoulder straps.

- 4.3.4 **Adjustable Waist Strap** - The carrier shall have two detachable, adjustable waist straps as per drawing #5 and the viewing sample. The waist strap component sewn into the front pouch seam shall be made with webbing as specified in Para. 4.1.5.1 measuring 3.8 cm wide. The female portion of the buckle as specified in Para. 4.1.6.1 shall be secured to one end. The finished length shall be 5 cm between the front side seam and the beginning of the buckle as outlined in drawing #2. The waist strap shall be made of elastic as specified in Para. 4.1.4, and shall be 3.8 cm wide, with an extended length of 44 cm \pm 1 cm as per drawing #5. Each waist strap shall have hook tape as specified in Para. 4.1.3 measuring 3.8 cm x 7.5 cm \pm 0.5 cm sewn to both sides of the elastic at one end. There shall be a sliplock buckle as specified in Para. 4.1.6.3, permanently sewn to the opposite end as per drawing #5 and the viewing sample. The end of the waist strap with the double hook tape shall feed through the male portion of the side release buckle, specified in Para. 4.1.6.1, and then through the sliplock buckle specified in Para. 4.1.6.3, to finish the waist strap. The hook tape on the completed waist strap shall be attached to the back pouch. The waist straps shall be constructed in accordance with drawing #5 and the viewing sample.
- 4.3.5 **Padded Shoulder Pads** - Each Rifle Plate Carrier shall come with two padded shoulder pads. The pads shall be constructed using shell material specified in Para. 4.1.1 on one side and lining material specified in Para. 4.1.2 on the other side with an inner layer of neoprene padding as specified in Para. 4.1.10. The shoulder pad shall measure 17 cm x 6.5 cm \pm 0.5 cm. There shall be a flap extension measuring 13.5 cm x 8 cm \pm 0.5 cm inserted into the side seam of the shoulder pad between the shell material specified in Para. 4.1.1 and the lining material specified in Para. 4.1.2. There shall be two pieces of elastic as specified in Para. 4.1.4, measuring 2.54 cm x 6.4 cm long \pm 0.5 cm, positioned on the inside of the pad as per drawing #8 and the viewing sample. There shall be a piece of loop tape measuring 1.6 cm x 13.5 cm \pm 0.5 cm as specified in Para. 4.1.3, affixed with one row of stitching 3 mm gauge on outer edge of the inner side of the pad. There shall be a piece of hook tape as specified in Para. 4.1.3, measuring 1.6 cm x 13.5 cm \pm 0.5 cm stitched on all sides at 3 mm gauge on the outer edge of the flap extension of the pad. The padded shoulder pads shall be manufactured in accordance with drawing #8 forming part of this specification and the viewing sample.
- 4.4 **Carrier, Plate, Rifle, Blank Patch** - The patch shall be constructed from shell material specified in Para. 4.1.1 and shall measure 16 cm x 6 cm \pm 0.5 cm as per drawing #8. The back of the blank patch shall have hook tape as specified in

Para. 4.1.3, measuring the same size as the patch stitched with 3 mm gauge on the back side of the material. There shall be a label as specified in Para. 4.5.2 stitched on the side end of the hook tape.

4.5 **Labelling** - A permanent label shall be placed on each rifle plate carrier back pouch on the wear (body) side. The label information shall be as outlined below in a font no less than size 10. The text shall be permanent ink in a contrasting colour and shall withstand at least 50 washes showing no apparent change in appearance. The label shall be large enough to print all required information legibly.

4.5.1 **Marking & Cleaning Instructions Label for the Pouch** - The label shall be completed in accordance with the following information in English and French.

1. Print information as shown below.
2. Print information as shown below.
3. Print information as shown below.
4. Print information as shown below.
5. Date of manufacture, in numeric format year/month (Ex. 2001/11)
6. Your manufacturer identification (Company name or number).
7. Print information as shown below.
8. Print information as shown below.
9. Print information as shown below.
10. Print information as shown below.
11. Print information as shown below.
12. Print information as shown below.

1	Carrier, Plate, Rifle	
2	gilet pare-balles	
3	RCMP-GRC # 122032	
4	One Size – Taille unique	
5		
6		
7	THIS SIDE AGAINST BODY / CE CÔTÉ CONTRE LE CORPS	
8	HANDLE WITH CARE - DO NOT DROP / MANIPULER AVEC SOINS – NE PAS ÉCHAPPER	
9	<p>THIS RIFLE PLATE CARRIER DOES NOT PROVIDE BALLISTIC PROTECTION BY ITSELF. IT MUST BE WORN WITH APPROVED RCMP RIFLE PLATES.</p> <p>CETTE ENVELOPPE POUR PLAQUES BALISTIQUES N’OFFRE AUCUNE PROTECTION CONTRE LES PROJECTILES SI ELLE NE CONTIENT PAS DES PLAQUES DE PROTECTION BALISTIQUE APPROUVÉES PAR LA GRC.</p>	
10	Machine wash - warm (40°C)	Laver à la machine - eau tiède (40°C)
11	Do Not use fabric softener or chlorine bleach	Ne pas utiliser d’agent adoucissant ou d’agent de blanchiment
12	Tumble dry- low (Do Not use dryer sheets)	Séchage par culbutage – à basse température (Ne pas utiliser d’assouplissant en feuilles)

Note: The manufacturer’s identification shall not appear anywhere on the garment except on the label as indicated.

4.5.2 **Marking Label for the Blank Patch** - The label shall be completed in accordance with the following information in English and French.

1. Print information as shown below.
2. Print information as shown below.

1	123169	
2	Carrier, Plate, Rifle, Blank Patch	Pièce unie pour gilet pare-balles

5. **Quality Assurance Provisions**

5.1 **Responsibility for Inspection** - Unless otherwise stipulated in the contract, it is the prime contractor's responsibility to satisfy the R.C.M.P., Uniform and Equipment Program that the material and services being supplied conform to this

specification. This may be accomplished by performing the tests specified in this specification or by demonstrating to the satisfaction of the R.C.M.P., Uniform and Equipment Program that conformity to this specification of manufacturing processes is assured. The contractor may use his own facilities or any commercial testing establishment acceptable to the R.C.M.P., Uniform and Equipment Program.

- 5.2 The R.C.M.P., Uniform and Equipment Program reserves the right to perform any inspection considered necessary to ensure the material and services conform to the specified requirements. For the purpose of inspection, a portion of each delivery not exceeding two percent or two out of any number delivered under 100 may be put to tests that could destroy the articles. If found to be inferior or not in accordance with this specification, all articles so destroyed shall be replaced by others of proper quality and pattern at the expense of the contractor. The entire delivery may also be rejected if it is found that articles previously rejected due to non-repairable defects are redelivered for inspection.
- 5.3 The contractor will be promptly notified when any articles are not accepted and such articles will be returned at the contractor's risk and expense.

TABLE I
Shell Material

	REQUIREMENT	ACCEPTABLE TESTED METHODS
Colour	Dark Navy, to match swatch available from RCMP Uniform & Equipment Program	
Fibre Content	100% Nylon 1000 denier	---
Weave	Plain	Visual
Mass	Fabric: 285 g/m ² - 363 g/m ² (8.4 oz/yd ² - 10.7 oz/yd ²) Coating: 34 g/m ² (1oz/yd ²) minimum	<ul style="list-style-type: none"> • CAN/CGSB-4.2 Method 5.1 <u>or</u> • ASTM D-3776 <u>or</u> • Fed. Std. 191 - 5041
Yarns per cm	Warp: 13 min. Weft: 10 min.	<ul style="list-style-type: none"> • CAN/CGSB-4.2 Method 6 <u>or</u> • ISO 7211-2 <u>or</u> • Fed. Std. 191 - 5050
Breaking Strength - Grab Method	Warp: 1300 N min. Weft: 1300 N min.	<ul style="list-style-type: none"> • CAN/CGSB-4.2 Method 9.1
Tearing Strength - Tongue Method	Warp: 180 N (40.8 lbs) min. Weft: 180 N (40.8 lbs) min.	<ul style="list-style-type: none"> • CAN/CGSB-4.2 method 12.1
Resistance to Surface Wetting - Spray Method	100 initial	<ul style="list-style-type: none"> • CAN/CGSB-4.2 Method 26.2 <u>or</u> • ISO 4920 <u>or</u> • Fed. Std. 191 - 5526
Colourfastness - To Crocking	Dry: Grade 4 or better Wet: Grade 3 or better	<ul style="list-style-type: none"> • CAN/CGSB-4.2 Method 22 <u>or</u> • ISO 105-C01
Colourfastness - To Perspiration	Grade 4 or better	<ul style="list-style-type: none"> • CAN/CGSB-4.2 Method 23 <u>or</u> • ISO 105-E-04

Scale of Measurements

Carrier, Plate, Rifle Dimensions					
	Pouch Width	Pouch Height	Angle Height	Top Pouch Width	Side Piece Width
ONE SIZE	26	32	11	20	3.2
Tolerance (cm)	± 1	± 1	+ 0.5	± 0.5	+ 0.5
Measurement Location	A	B	C	D	E

Note: All measurements are in centimetres unless otherwise specified.

Scale of Measurement Location

Dwg. 1

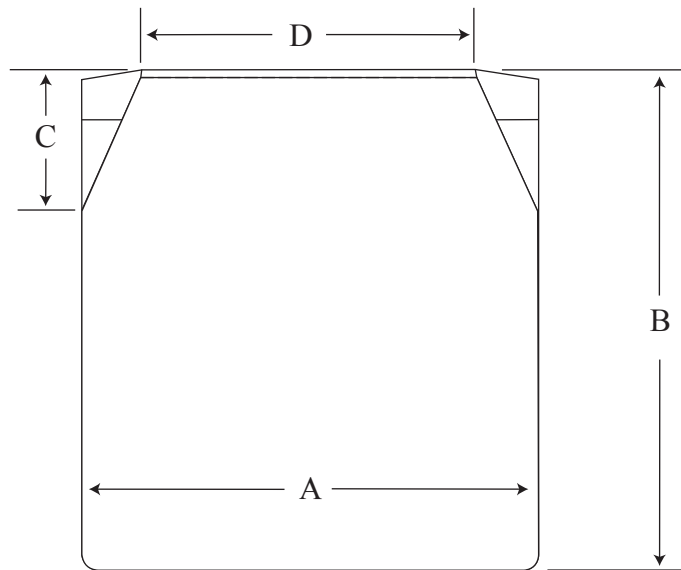
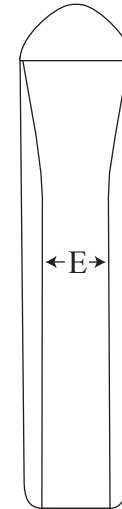

Plate Pouch



Side Piece Plate Pouch

All Measurements in Centimetres unless otherwise marked
Unless otherwise stated all measurements are subject to ± 0.5 cm tolerances.
NOT TO SCALE

Front Plate Pouch
(Shown without Adjustable Waist Strap)

Dwg. 2

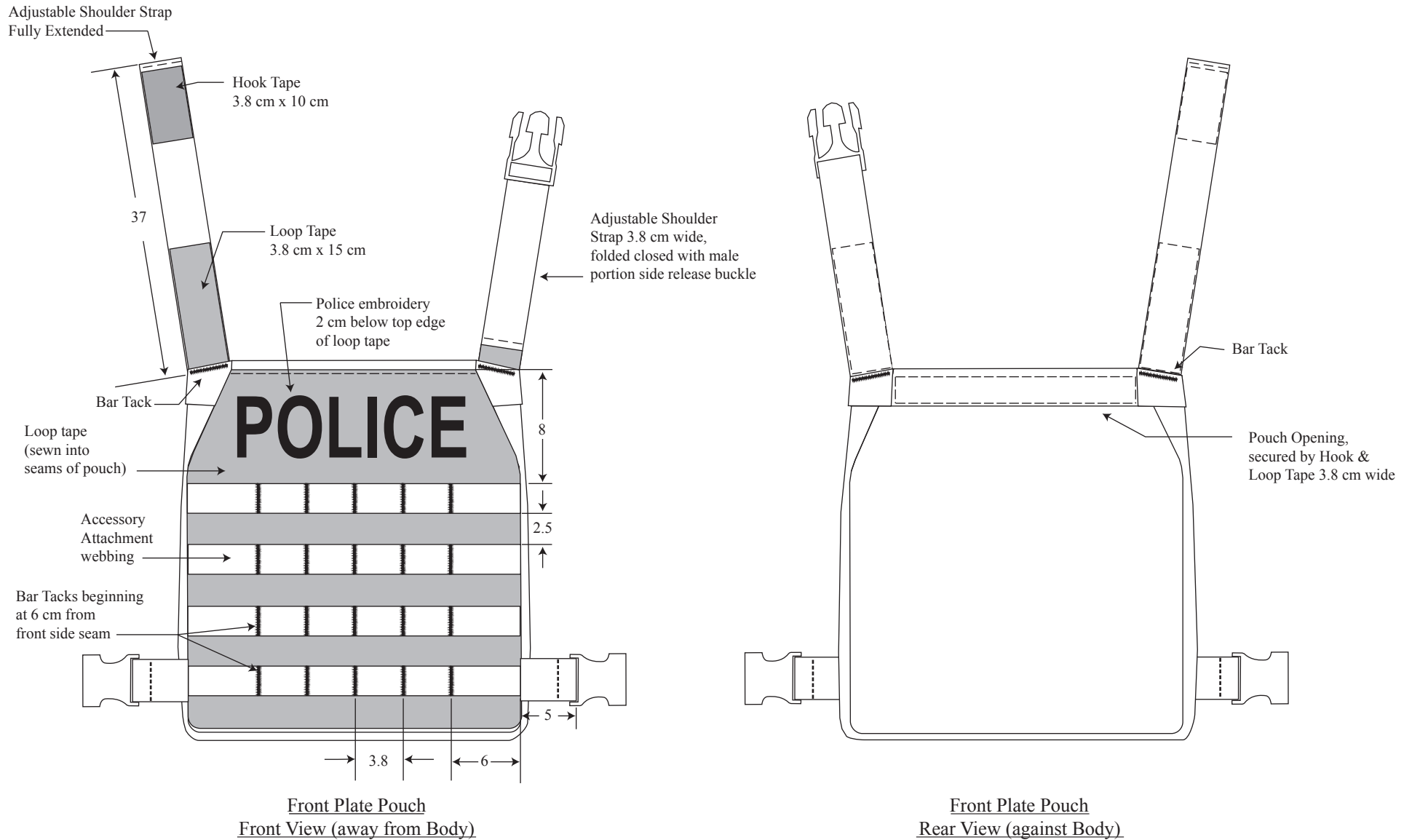

All Measurements in Centimetres unless otherwise marked
 Unless otherwise stated all measurements are subject to ± 0.5 cm tolerances.
 NOT TO SCALE

Back Plate Pouch
(Shown without Adjustable Waist Strap)

Dwg. 3

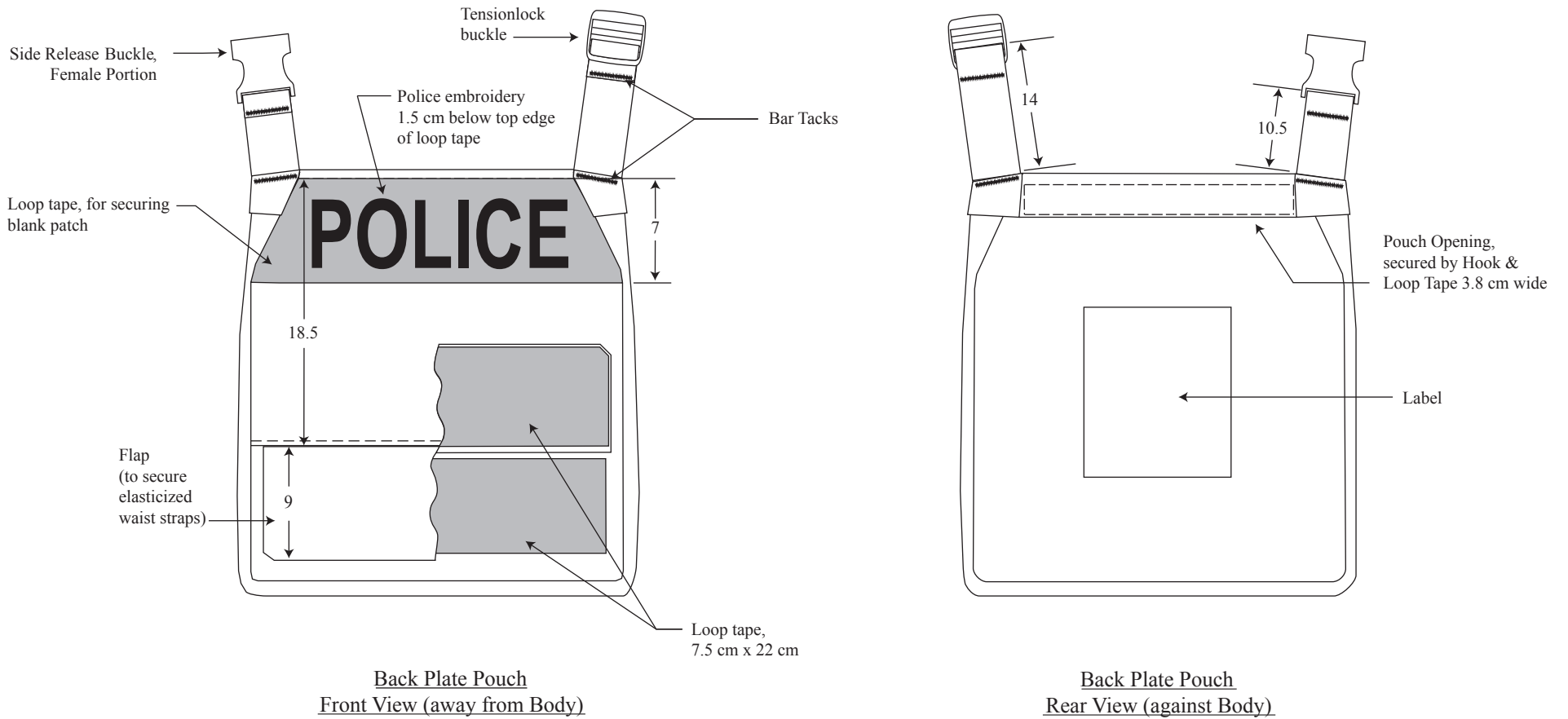

All Measurements in Centimetres unless otherwise marked
Unless otherwise stated all measurements are subject to ± 0.5 cm tolerances.
NOT TO SCALE

Pouch Opening and Side Piece

Dwg. 4

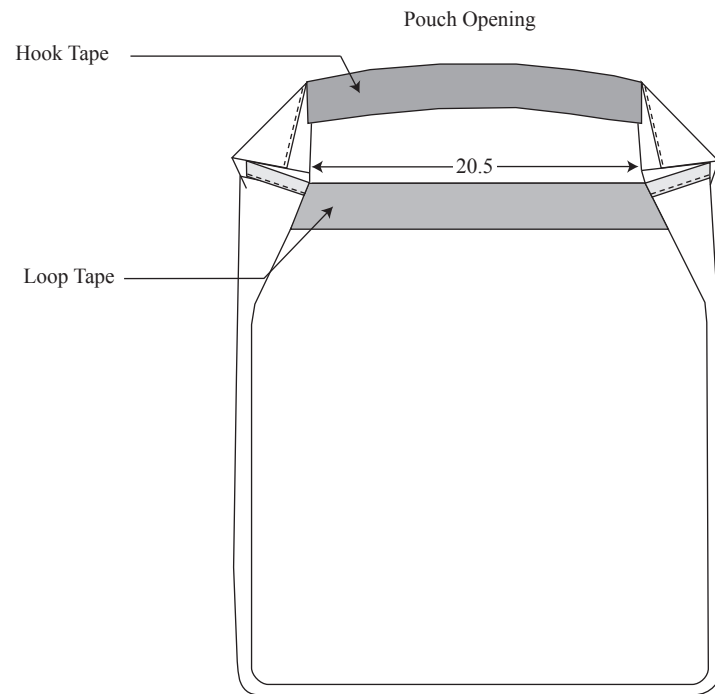

Plate Pouch,
Rear View (against Body)

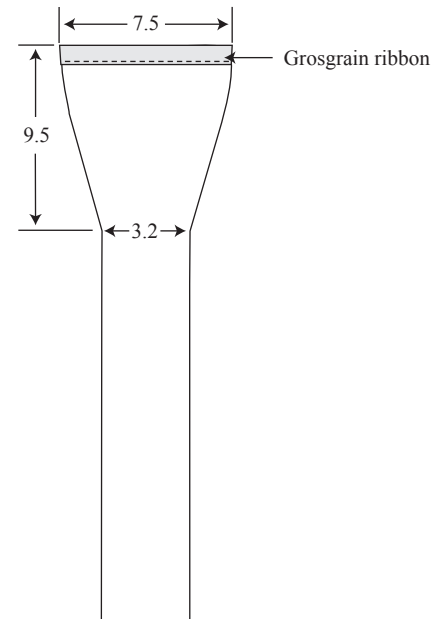
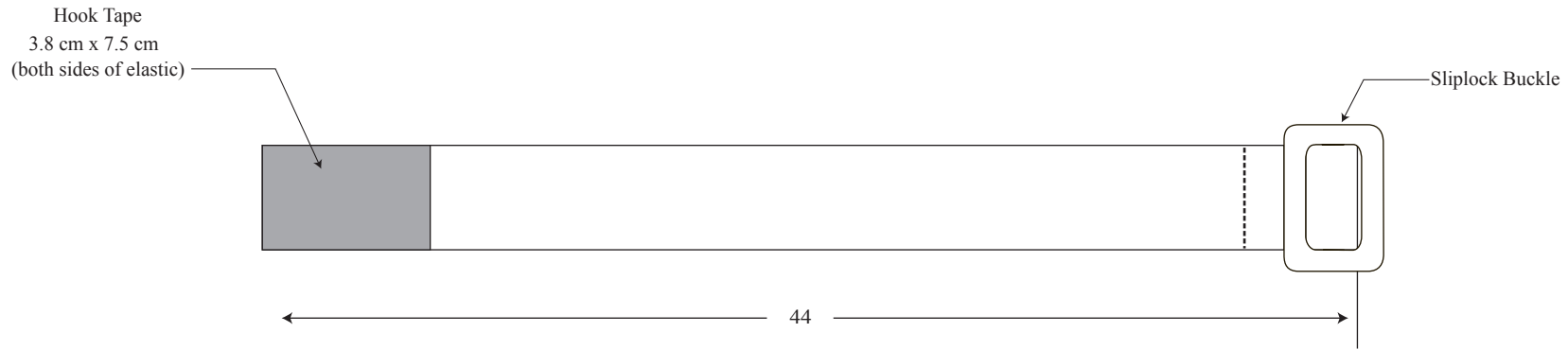

Plate Pouch Side Piece,
Side View

All Measurements in Centimetres unless otherwise marked
Unless otherwise stated all measurements are subject to ± 0.5 cm tolerances.
NOT TO SCALE

Adjustable Waist Strap

Dwg. 5



Adjustable Waist Strap
(shown full length without male portion of side buckle)

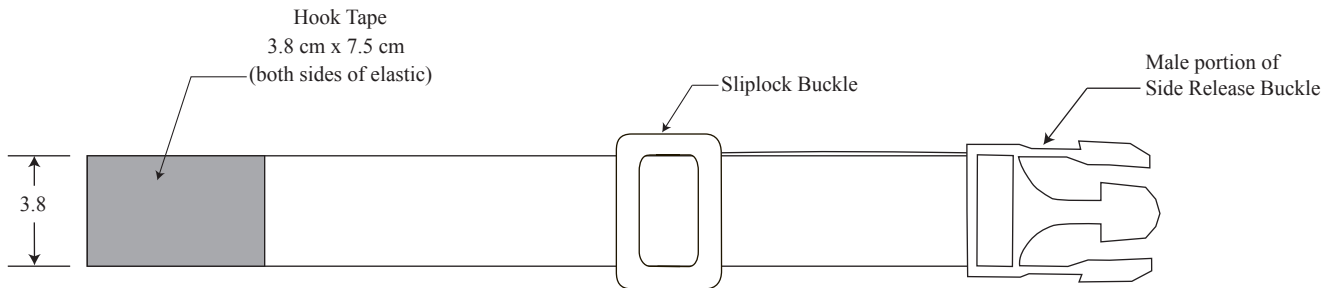

Adjustable Waist Strap
(shown folded with male portion of side buckle attached)

All Measurements in Centimetres unless otherwise marked
Unless otherwise stated all measurements are subject to ± 0.5 cm tolerances.
NOT TO SCALE

“POLICE” Embroidery Dimensions, Front & Back

Dwg. 6



“POLICE” Embroidery Size

All Measurements in Centimetres unless otherwise marked
Unless otherwise stated all measurements are subject to ± 0.5 cm tolerances.
NOT TO SCALE

Shoulder Pads & Blank Patch

Dwg. 7

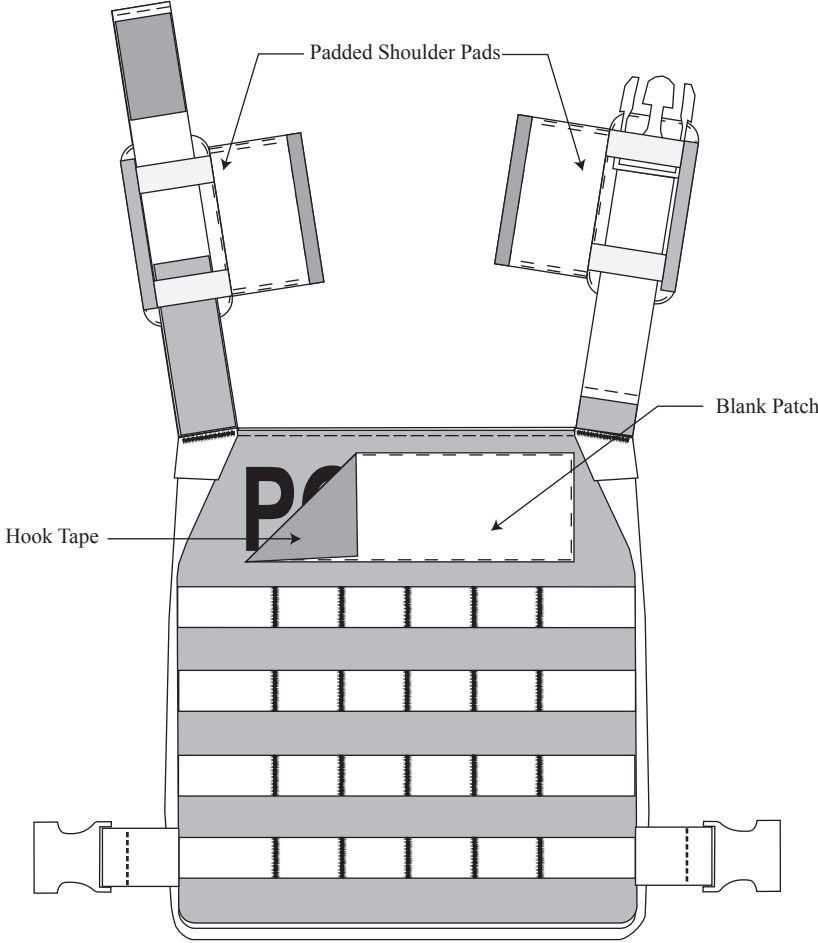

Front Plate Pouch
With Blank Patch

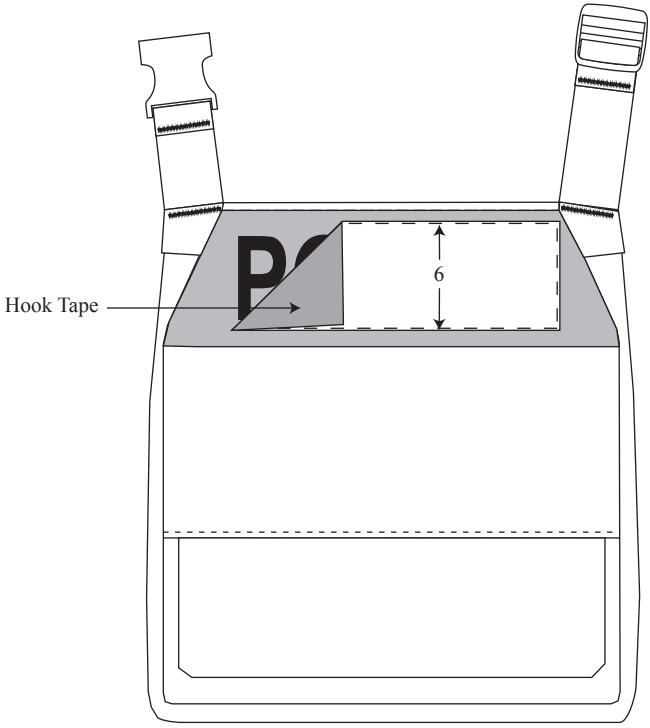

Back Plate Pouch
With Blank Patch

All Measurements in Centimetres unless otherwise marked
Unless otherwise stated all measurements are subject to ± 0.5 cm tolerances.
NOT TO SCALE

Shoulder Pads & Blank Patch

Dwg. 8

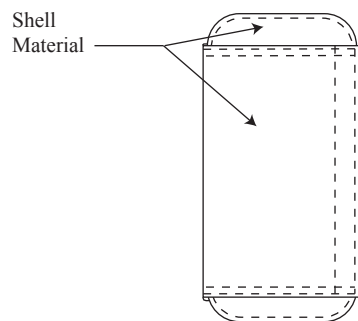

Padded Shoulder Pad (Closed)

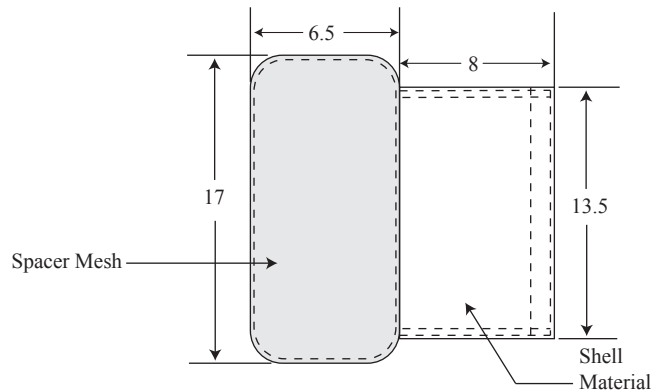

Padded Shoulder Pad (Open - Outside)

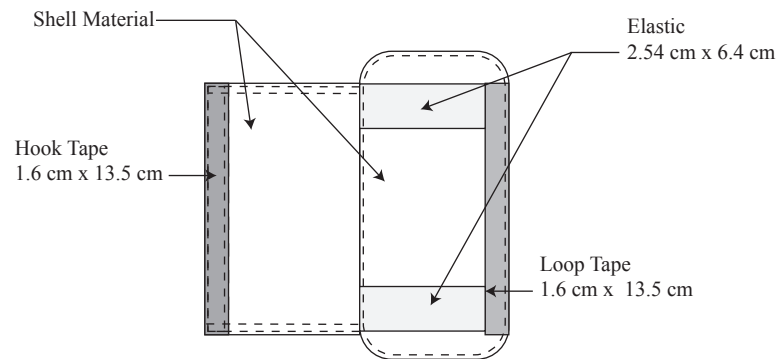

Padded Shoulder Pad (Open - Inside)

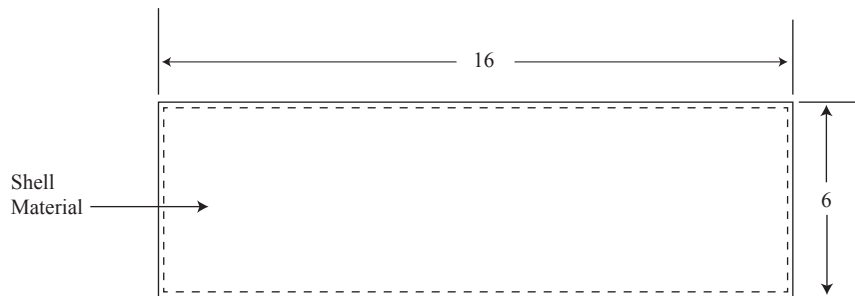

Blank Patch (Front)

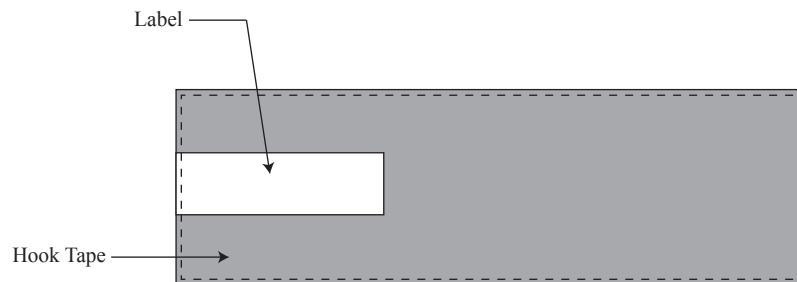

Blank Patch (Back)

All Measurements in Centimetres unless otherwise marked
Unless otherwise stated all measurements are subject to ± 0.5 cm tolerances.
NOT TO SCALE