



Fisheries and Oceans
Canada

Pêches et Océans
Canada

Canadian
Coast Guard

Garde côtière
canadienne



NAV AID REPLACEMENT AND REMOVAL

LL 549.2 YELLOW BLUFF SECTOR

ALERT BAY, BC

MARITIME AND CIVIL INFRASTRUCTURE

Prepared by: BT

Approved by: PG

Revision: 0

Rev Date: 30 NOV 2015



TABLE OF CONTENTS

SECTION: 011100 GENERAL INSTRUCTIONS 1

SECTION: 013300 SUBMITTAL PROCEDURES 5

SECTION: 013530 HEALTH AND SAFETY REQUIREMENTS 6

SECTION: 013543 ENVIRONMENTAL PROCEDURES 7

SECTION: 014500 QUALITY CONTROL..... 9

SECTION: 024116 DEMOLITION OF STRUCTURES..... 10

SECTION: 055000 METAL FABRICATIONS 12

SECTION: 133613 METAL TOWERS..... 14

SECTION: 316113 PILE FOUNDATIONS..... 15



Part 1 General Instructions

1.1 MINIMUM STANDARDS

- .1 Perform work in accordance with the National Building Code of Canada (NBC) and any other code of provincial or local application. In the case of any conflict or discrepancy, the more stringent requirements shall apply.
 - .1 Meet or exceed the requirements of:
 - .1 Contract Documents;
 - .2 Specified standards, codes and referenced documents.

1.2 DESCRIPTION OF WORK

- .1 Work under this Contract include but is not limited to the provision of all labour, materials, and equipment required to:
 - .1 Mobilize to site with a work barge of appropriate size and certification;
 - .2 Install one new three pile dolphin;
 - .3 Install CCG supplied equipment on this dolphin;
 - .1 8' x 10' Galv. steel platform
 - .2 12' tower and equipment
 - .3 2 sections of galvanized steel access ladder
 - .4 2 Hanging anode assemblies
 - .4 Demolish and dispose existing pile supported reinforced concrete pier;
 - .5 Return the existing aid to navigation including all lighting and electrical equipment to CCG;
 - .6 Demobilize.
- .2 The following work will be undertaken by others and must be accommodated during construction
 - .1 Installation of Navigational Light and electrical equipment by Canadian Coast Guard (CCG) Lamproom Staff.
 - .2 Review of works by Environmental Monitor, under separate contract.
 - .3 Observation of construction activities by First Nations Observer, if present.
 - .4 Survey of Navigational Aid by qualified professional surveyor, under separate contract.
- .3 The following items will be supplied by Canadian Coast Guard and are hereby excluded:
 - .1 Supply one (1) Aluminium tower
 - .2 Supply one (1) Galvanized steel platform
 - .3 Supply two (2) Galvanized steel access ladders
 - .4 Supply two (2) Hanging anode assemblies



1.3 SUBMITTALS

- .1 Mandatory submittals and schedule for submission are detailed below and in Appendix B2. The following identifies general requirements only; the relevant sections must be consulted for a complete listing of mandatory content.
- .2 Detailed Schedule:
 - .1 Deadline:
 - .1 No later than ten (10) working days following award.
 - .2 Deliverables:
 - .1 The Contractor must furnish a high level schedule outlining the major construction milestones. Schedule must clearly define the anticipated start and finish of the project.
- .3 Proof of Qualifications:
 - .1 Deadline:
 - .1 No later than ten (10) working days following award.
 - .2 Deliverables:
 - .1 Contractor must furnish proof of CWB Div. 3 certification for welder/fabricators.
 - .2 Contractor must furnish proof of vessel registration.
 - .3 Contractor must furnish listing of all subcontractors.
- .4 Construction Plan:
 - .1 Deadline:
 - .1 No later than ten (10) working days prior to mobilization.
 - .2 Deliverables:
 - .1 A Construction Plan of sufficient detail to demonstrate that the Contractor has considered all the challenges of the project and is prepared to undertake the works in a competent and professional manner in accordance with all legislation, and including:
 - .1 Project specific safety program (Section 013530);
 - .2 Project environmental protection plan (Section 013543);
 - .3 Detailed demolition plan (Section 024116);
 - .4 Detailed erection plan (Section 055000);
 - .5 Detailed pile driving plan (Section 316113).

1.4 BIDDER QUALIFICATIONS

- .1 The work must be carried out under the supervision and responsibility of a sole specialized Contractor, capable of performing installations of offshore pile foundations.
- .2 The Contractor must designate a project manager or main point of contact for the contract.
- .3 The Contractor must provide a detailed list of all subcontractors being used to complete the work described herein.



1.5 SITE LOCATION

- .1 The identification and location of the aid is as follows:
 - .1 LL 549.2 Yellow Bluff Sector Lat:50° 35' 12.8"N Long:126° 57' 03.1"W.
 - .2 The closest settlement is Alert Bay, BC.
 - .3 The site is located on unsurveyed foreshore situated within the Broughton Straight, on a cobble beach off the southwest end of Cormorant Island at the entrance to Alert Bay.

1.6 EXISTING CONDITIONS

- .1 Bidders must make their own estimate of the difficulties associated with all phases of the works,
- .2 The Contractor must include in their costs all expenses related to the difficulties of working at the sites.
- .3 A geotechnical investigation has not been completed for the site.

1.7 CONTRACTOR'S ACCESS TO SITE

- .1 Contractor is responsible for all transport of all labour, materials, and equipment to and from the site, including any and all material furnished or itemized for salvage by Canadian Coast Guard.
- .2 Site is water accessible only, located on the foreshore of Cormorant Island.
- .3 The Contractor is responsible for supplying appropriate marine access to support all construction work. Contractors are also responsible for ensuring that all the requirements of Appendix B3 Marine Access Requirements are met.
 - .1 Contractor must provide proof of vessel registration in the 'proof of qualifications' submittal.

1.8 COMPLETION, SCHEDULING, AND PLANNING OF WORKS

- .1 Work may commence as early as practical following Canadian Coast Guards acceptance and approval of mandatory submissions.
- .2 Work must be completed no later than March 15, 2016, unless otherwise negotiated and approved in writing.
- .3 Demolition of the existing Aid to Navigation must not commence until the new Aid to Navigation is fully commissioned.

1.9 COAST GUARD STAGING LOCATION

- .1 Items identified as supplied by, or salvaged to Canadian Coast Guard must be collected or delivered by the Contractor to the following staging location. Unless otherwise negotiated and approved in writing. The contractor will be responsible for all transportation costs between the project site and the identified Canadian Coast Guard staging area. Material drop off or access to stored goods outside regular operating hours will be at the discretion of Coast Guard and may be subject to cost recovery.
 - .1 Staging Location: CCG Base Shoal Point – 25 Huron Street Victoria, BC V8V 4V9
 - .2 Advise Coast Guard at least three (3) working days prior to pick up/delivery;
 - .1 For delivery or pick-up, contact: Steve James, (250) 480-2608



.2 Shipping/Receiving hours: Monday through Friday, 9:00AM to 3:00PM.

1.10 TEMPORARY FACILITIES

- .1 Provide sanitary facilities for work force in accordance with governing regulations and ordinances.
- .2 Maintain emergency spills kit on-site at all times.

1.11 NOTIFICATIONS

- .1 The Contractor must notify the local Fisheries Officer not less than five (5) days prior to commencement of the work.
- .2 Contractor must notify Canadian Coast Guard, Vessel Traffic Services, and inform them of operations to allow them to issue any necessary notices to shipping prior to commencement of the work.

1.12 FEES, PERMITS, CERTIFICATES AND INFORMATION

- .1 Contractor must provide authorities having jurisdiction with all information requested.
 - .1 Contractor must provide copies to Coast Guard of any documentation submitted to other authorities related to the work described in this document.
- .2 Contractor must pay fees and obtain certificates and permits required.
- .3 Contractor must furnish certificates and permits when requested.

1.13 REFERENCE DOCUMENTS

- .1 The most recent publication or edition of any document referenced in this specification should be used unless the referencing clause states that this clause does not apply.

1.14 REQUIRED SUBMISSIONS

- .1 A summary of the minimum mandatory submissions required can be found in Appendix B2. This summary is not an exhaustive list of all submissions required for the duration of the project. Additional submissions may be required afterward.



Part 1 General

1.1 GENERAL

- .1 This section specifies the general requirements and procedures for the Contractor's submissions of documents to Canadian Coast Guard for review.
- .2 Do not proceed with the work until submitted documents have been reviewed by Canadian Coast Guard
- .3 Where items or information is not produced in SI Metric units, converted values are acceptable.
- .4 Contractor's responsibility for errors and omissions in submissions is not relieved by Canadian Coast Guard's review of the submitted documents.
- .5 Notify Canadian Coast Guard in writing at time of submission, identifying deviations from requirements of Contract Documents stating reasons for deviations.
- .6 Contractor's responsibility for deviations in submission from requirements of Contract Documents is not relieved by Canadian Coast Guard's review of submission, unless Coast Guard gives written acceptance of specific deviations.
- .7 Make any changes to submissions that Canadian Coast Guard may require consistent with Contract Documents and resubmit as directed by Coast Guard.
- .8 Provide Canadian Coast Guard with a written notice, when resubmitting, of any revisions other than those requested by Coast Guard.

1.2 SUBMISSION REQUIREMENTS

- .1 Coordinate each submission with requirements of work and Contract Documents. Individual submissions will not be reviewed until all related information is available.
- .2 Allow three (3) working days, or as stipulated in the specifications, for Canadian Coast Guard to review the submission.
- .3 The Contractor's Engineer must stamp and sign any submissions requiring a Professional Engineer's seal certifying their approval of samples, verifications of field measurements, and compliance with Contract Documents.



Part 1 General

1.1 SCOPE OF WORK

.1 The Contractor must develop, implement and enforce a safety program which addresses all elements of the work.

.1 Due to the specific requirements of the project the Contractor is required to include the following as minimum mandatory requirements of their submitted safety program.

.1 A safety plan.

1.2 REFERENCES

.1 Work under this section must be undertaken in strict conformance with all listed references, in the case of any conflict of discrepancy the more stringent requirements will apply.

.1 Canada Labour Code Part II, January 2008

.2 NRC-CNRC National Building Code of Canada, 2010

.3 BC Workers Compensation Act, 2015

.4 Any and all other Provincial/Territorial Regulations and Policies; Worker's Compensation Board Policies; Local municipal regulations; pertaining to safety of the contractors workers.

1.3 SUBMITTALS

.1 Project Specific Safety Plan

.1 Deadline:

.1 With Construction Plan

.2 Deliverables:

.1 Safety Plan Documents must include:

.1 A listing of all activities specific to the project and their Health and Safety risks or hazards.

.2 Detailed descriptions of how the activities are to be carried out as well as methods for mitigating hazards and risks.

.3 A listing or personnel responsible for health and safety measures, and emergency procedures.

.4 Material Safety Data Sheets for hazardous products to be utilized in the performance of the works.



Part 1 General

1.1 SCOPE OF WORK

- .1 The Contractor must implement and enforce the following procedures throughout the duration of work to mitigate potential negative impacts on the surrounding environment.
- .2 At the Canadian Coast Guards sole discretion an Environmental Monitor may be present during the removal and installation of marine structures and related work.

1.2 REFERENCES

- .1 Work under this section shall be undertaken in strict conformance with all listed references, In the case of any conflict or discrepancy the more stringent requirements will apply.
 - .1 Canadian Environmental Protection Act.
 - .2 Environmental Review – LL 549.2 Yellow Bluff Sector Navigational Aid 2015
 - .3 Best Management Practices for Pile Driving and Related Operations - BC Marine and Pile Driving Contractors Association March 2003

1.3 SUBMITTALS

- .1 Contractor must submit an environmental protection plan
 - .1 Deadline:
 - .1 With Construction Plan
 - .2 Deliverables:
 - .1 Submit a plan addressing procedures to be implemented to mitigate any negative impact on the environment. Detail:
 - .1 Equipment features (age, spill containment);
 - .2 Staging, refueling and cleaning areas;
 - .3 Clean-up and/or containment procedures;
 - .4 Waste disposal methods and sites.

Part 2 Products

2.1 General

- .1 Avoid use of hazardous products. Use environmentally friendly products where practical.

Part 3 Execution

3.1 Construction Area

- .1 Confine construction activities to as small an area as practical.
- .2 Establish material storage, cleaning, and refueling areas where impacts to the surrounding environment will be negligible or readily mitigated.



- .3 Standard mitigation practices and waste management procedures must be followed throughout the construction process; see Appendix B4

3.2 Barge Operations

- .1 Ensure no grounding of the vessel. If grounding becomes imperative Contractor must conduct a visual inspection first to ensure no grounding occurs on eel grass.



Part 1 General

1.1 INSPECTION

- .1 Canadian Coast Guard or its representatives along with Environmental Monitors or First Nations Observers must have access to the work at all times. If parts of the work are prepared off site or in a shop, access must be given to such work areas throughout the duration of the project.
- .2 The list below identifies key milestones where the Canadian Coast Guard will require an opportunity to inspect and document the work.
 - .1 Location Verification: The Coast Guard will confirm the correct location for installation upon arrival of the barge at site. The contractor must provide access to the site at all times to CCG site representatives.
 - .2 Installation of the Tower: The Coast Guard must witness the erection of the new nav-aid tower and witness the correct operation of the new light.
 - .3 Demolition of Existing Tower: The Coast Guard must witness the demolition of the existing structure.
- .3 Assistance by Contractor
 - .1 Co-operate with Canadian Coast Guard representatives and provide transportation assistance to work barge.
 - .2 On request of the Canadian Coast Guard or representative furnish for their use such, boats, equipment, labour and materials that would ordinarily form part of the plant as necessary to inspect and supervise the work at all times.
 - .3 Lamproom Staff and Marine Surveyor will provide their own transport to the work barge and for the completion of their duties.

1.2 PROCEDURES

- .1 Provide Canadian Coast Guard with advance notice whenever testing or inspection is required in accordance with these specifications, so that all parties involved can be present.
- .2 Provide necessary manpower and installations for obtaining and handling samples and material on site.
- .3 Provide access to site and work barge to CCG staff if the site is remote.

1.3 REJECTED WORK

- .1 Remove defective work, whether incorporated into the work or not, which has been rejected by Canadian Coast Guard as failing to comply with the contract documents, replace or re-execute in accordance with the Contract Documents.

1.4 ACCEPTANCE OF WORK

- .1 Canadian Coast Guard will make acceptance visits of work executed by the contractor at critical milestones identified.
 - .1 The Contractor must inform the Canadian Coast Guard at least three (3) working days before these inspection visits.



Part 1 General

1.1 SCOPE OF WORK

- .1 Work under this section consists of the provision of all labour, materials, and equipment necessary to complete the following activities:
 - .1 Demolition of the existing pile supported reinforced concrete pier.
 - .1 This includes the existing aid to navigation which is not to be disturbed until installation and commissioning of the new tower is complete.
 - .2 Disposal of all waste at a licensed waste disposal facility;
 - .3 Transportation of the old tower, including all lighting and electrical equipment to Victoria CCG base.

1.2 REFERENCES

- .1 Work under this section must be undertaken in strict conformance with all listed references, In the case of any conflict or discrepancy the more stringent requirements shall apply.
 - .1 Canada Labour Code Part II – January 2008.
 - .2 NRC-CNRC National Building Code of Canada 2010.
 - .3 BC Workers Compensation Act, 2015
 - .4 CSA-S350-[M1980(R2003)], Code of Practice for Safety in Demolition of Structures.

1.3 SUBMITTALS

- .1 Contractor to provide demolition plan.
 - .1 Deadline:
 - .1 With Construction Plan.
 - .2 Deliverables:
 - .1 Method of demolition including all associated tasks and schedule;
 - .2 Methods for protecting the site from demolition debris
 - .3 The ultimate disposal location of all waste material and debris.
 - .1 Include documentation detailing regulatory approval for waste disposal facility and transporter.
- .2 Work under this section must not proceed until written approval of the demolition plan had been received from the Coast Guard
- .3 Contactor must submit copies of certified receipts from the disposal sites for all materials removed from the work site upon request.

1.4 Existing Conditions

- .1 Existing pile supported reinforced concrete pier is beyond its life expectancy, and signs of failure are present. Contractor must ensure the tower and foundation are dismantled and demolished in a safe manner.



Part 2 Products

2.1 Not Used.

Part 3 Execution

3.1 GENERAL

- .1 Work under this section must be continuous and proceed without interruption unless otherwise approved by Coast Guard, to avoid a hazard to navigation.
- .2 It is preferred that pieces are lifted onto the barge in intact sections to avoid environmental issues.
- .3 Demolition work shall not commence until the new three pile dolphin and aid to navigation are complete and operational.

3.2 PROTECTION

- .1 Implement effective controls to catch/collect all debris during demolition,
- .2 Implement effective controls to prevent injury to workers and mariners.

3.3 PREPARATION

- .1 Ensure all environmental protection/mitigation measures are in place.
- .2 Ensure all items identified for salvage have been safely removed and stored.

3.4 Demolition

- .1 Demolish existing pile supported reinforced concrete pier in its entirety.
- .2 Remove and salvage old frp tower and electrical equipment in their entirety.
- .3 Ensure that demolition does not adversely affect adjacent watercourses, groundwater and wildlife or contribute to excess air and noise pollution.
- .4 Ensure demolition is undertaken safely, If at any period during the demolition the safety of the Contractor's staff cannot be maintained take preventative measures, stop work and immediately notify Coast Guard.



Part 1 General

1.1 SCOPE OF WORK

- .1 Work of this section includes the supply of all labour, material, and equipment, necessary to complete the following activities:
 - .1 Installation of pre-fabricated platform, anode assemblies, channel braces, shear plates, and access ladder including field welds as indicated in the attached drawings found in Appendix B1.

1.2 REFERENCES

- .1 Work under this section must be undertaken in strict conformance with all listed references, in the case of any conflict or discrepancy the more stringent requirements will apply.
 - .1 Canada Labour Code Part II, 2008
 - .2 NRC-CNRC National Building Code of Canada, 2010
 - .3 BC Workers Compensation Act, 2015
 - .4 CAN/CSA S16 Limit States Design of Steel Structures
 - .5 CAN/CSA W59 Welded Steel Construction
 - .6 CAN/CSA G40.21 Steel channels, angles and plates

1.3 SUBMITTALS

- .1 Contractor must provide an Erection Plan
 - .1 Deadline:
 - .1 With Construction Plan
 - .2 Deliverables:
 - .1 Description of the equipment that will be utilized to install components
 - .2 Description of how the works will be undertaken to mitigate impacts on the surrounding watercourse.

Part 2 Products

2.1 MATERIALS

- .1 Steel sections and plates: to CAN/CSA-G40.20/G40.21, Grade 300W.
- .2 Welding materials: to CSA W59.
- .3 Welding electrodes: to CSA W48.
- .4 Bolts and anchor bolts: to ASTM A325.

2.2 FABRICATION

- .1 Fabricate work square, true, straight and accurate to required size, with joints closely fitted and properly secured.
- .2 Prepare pre-fabricated hot dip galvanized materials prior to welding.



- .3 File or grind exposed field welds smooth and flush.
- .4 Field welds to be cleaned and painted with zinc rich cold galvanizing to ASTM A780M.

Part 3 Execution

3.1 ERECTION

- .1 Do welding work in accordance with CSA W59 unless specified otherwise. All welding must be carried out by a welding shop certified to CWB div. 3 or greater.
- .2 Erect metalwork square, plumb, straight, and true, accurately fitted, with tight joints and intersections.



Part 1 General

1.1 SCOPE OF WORK

- .1 Work of this section includes the supply of all labour, material, and equipment, necessary to complete the following activities:
 - .1 Transportation of the tower and all associated hardware to site from the designated staging area;
 - .2 The installation of the tower as indicated on the attached drawings
 - .3 The transportation and installation of the navigational day-marks
- .2 Work of the section excludes:
 - .1 Supply of the aluminium tower and hardware, by CCG
 - .2 Supply of the navigational day-marks and hardware, by CCG

1.2 REFERENCES

- .1 Work under this section must be undertaken in strict conformance with all listed references, in the case of any conflict or discrepancy the more stringent requirements will apply.
 - .1 Canada Labour Code Part II, 2008
 - .2 NRC-CNRC National Building Code of Canada, 2010
 - .3 BC Workers Compensation Act, 2015

1.3 SUBMITTALS

- .1 No submittals required in this section.

Part 2 Products

2.1 MATERIALS

- .1 The Canadian Coast Guard will supply eight (8) structural grade A325 double hex nut hardware, hot dip galvanized, to attach the tower base to the pre-fabricated platform.

Part 3 Execution

3.1 ERECTION

- .1 Bolting the tower to the studs
 - .1 Each stud must have two heavy hex nuts, galvanized.
 - .2 Contractor must tighten the first nut using turn of nut method associated to the size of stud provided. The second nuts must be snug tight to lock into place the two nuts.



Part 1 General

1.1 SCOPE OF WORK

- .1 Work of this section includes the supply of all labour, material, and equipment, necessary to complete the following activities:
 - .1 Installation of a three pile dolphin, as per the attached drawings;

1.2 SUBMITTALS

- .1 Contractor must provide a Pile Driving Plan
 - .1 Deadline:
 - .1 Furnish with Construction Plan (Section 011100)
 - .2 Deliverables:
 - .1 Description list and details of equipment for use in installation of piles. Impact hammers: submit manufacturer's written data as specified. Non-impact methods; submit characteristics to evaluate performance.
 - .2 Description of the methods that will be implemented to stabilize the pile equipment to ensure the proper vertical batter of piles.
 - .3 Describe how the works will be undertaken to mitigate impacts on the surrounding watercourse.

1.3 Quality Assurance

- .1 Coast Guards minimum inspection requirements are detailed below. The contractor must notify Coast Guard of the date and time that the works may be inspected, Notice must be provided no less than three (3) working days in advance to permit scheduling. All deficiencies in the works identified at the time of inspection must be remedied to the satisfaction of Coast Guard, by the Contractor at their expense. Work must not progress until inspections have been completed and the Contractor has been provided instruction to proceed with the works.
- .2 Coast Guard to confirm the correct pile driving position.
- .3 Coast Guard to witness all pile driving operations.

Part 2 Products

2.1 MATERIALS

- .1 Material requirements, piles as indicated on drawings in Appendix B1 must meet or exceed:
 - .1 ASTM/ASME A252/SA252 STEEL PILING PIPE GRADE 3
 - .2 CAN/CSA G40.21M Grade 300W
- .2 Supply or fabricate full length piles as indicated and provide equipment to handle full length piles without cutting and splicing.
- .3 Splice piles only with written approval of Coast Guard.
 - .1 When permitted, provide details for Coast Guard to review.



Part 3 Execution

3.1 PREPARATION

- .1 Protection:
 - .1 Protect adjacent structures, services and work of other sections from hazards due to pile driving operations.
 - .2 Arrange sequencing of pile driving operations and methods to avoid damages to adjacent existing structures.
- .2 Ensure that ground conditions at pile locations are adequate to support pile driving operations.

3.2 INSTALLATION

- .1 Installation of each pile will be subject to Coast Guard approval.
 - .1 Coast Guard will be sole judge of acceptability of each pile with respect to final driving resistance, depth of penetration or other criteria used to determine load capacity.
 - .2 Coast Guard to approve final driving of all piles prior to removal of pile driving rig from site.
- .2 Drive each pile to a final depth of penetration of 6.0 metres.

3.3 DRIVING TOLERANCES

- .1 Pile heads to be within 75 mm of locations as indicated.
- .2 Piles not to be more than 2% of length out of vertical alignment.

3.4 FIELD QUALITY CONTROL

- .1 Measurement:
 - .1 Maintain accurate records of driving for each pile, including:
 - .1 Type and make of hammer, stroke or related energy.
 - .2 Other driving equipment including water jet, driving cap, cushion.
 - .3 Pile size and length, location of pile in pile group, location or designation of pile group.
 - .4 Sequence of driving piles in group.
 - .5 Number of blows per metre for entire length of pile.
 - .6 Final tip and cut-off elevations.
 - .7 Other pertinent information such as interruption of continuous driving, pile damage.
 - .8 Record elevation taken on adjacent piles before and after driving of each pile.
 - .2 Provide Coast Guard with one copy of records.



Fisheries and Oceans
Canada

Pêches et Océans
Canada

Canadian
Coast Guard

Garde côtière
canadienne

APPENDIX B1 – DRAWINGS

GENERAL NOTES

1. THESE STRUCTURAL DRAWINGS ARE TO BE READ IN CONJUNCTION WITH ALL OTHER APPLICABLE CONSTRUCTION DOCUMENTS. DEVIATION OF PROJECT CONSTRUCTION IS NOT ACCEPTABLE UNLESS INSTRUCTED BY THE ENGINEER.
2. ALL INFORMATION CONCERNING EXISTING SITE CONDITIONS HAVE BEEN TAKEN FROM ORIGINAL DRAWINGS AND SITE MEASUREMENTS. SHOULD INFORMATION OR SITE CONDITIONS DIFFER SIGNIFICANTLY FROM THAT SHOWN, ADVISE CCG ENGINEERING.
3. DO NOT COMMENCE CONSTRUCTION USING THESE DRAWINGS UNLESS NOTED "FOR CONSTRUCTION".
4. CONSTRUCTION SHALL BE IN ACCORDANCE WITH THE NATIONAL BUILDING CODE 2010 AND REFERENCED STANDARDS THEREIN.
5. DRAWINGS SHOW COMPLETED STRUCTURES ONLY. CONTRACTOR IS RESPONSIBLE TO PROVIDE TEMPORARY STRUCTURES AND BRACING FOR CONSTRUCTION LOADING CONDITIONS AND STABILITY OF THE STRUCTURE DURING CONSTRUCTION. CONSTRUCTION LOADS SHALL NOT EXCEED THE DESIGN LOADS.

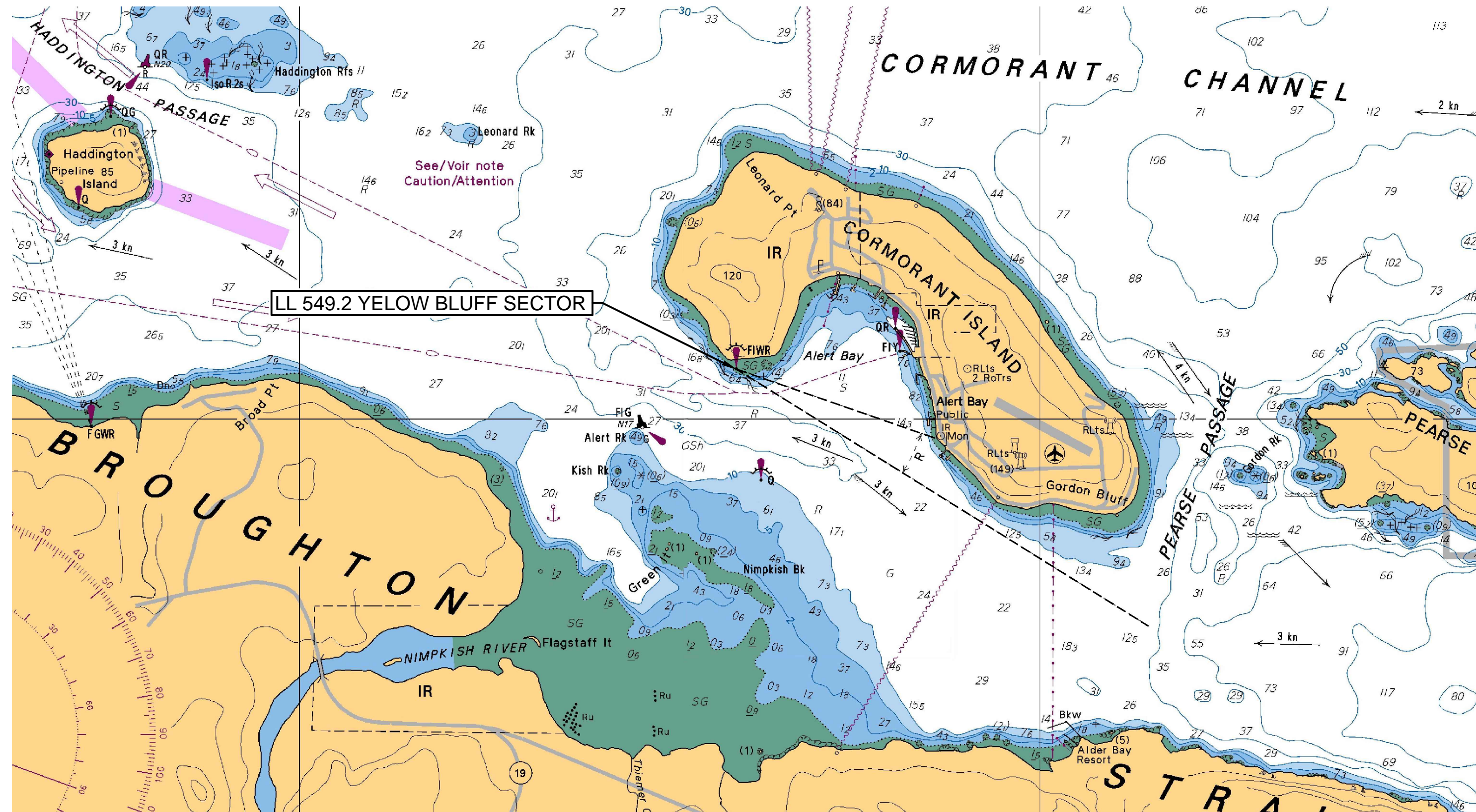

LOCATION CHARTLET (PART OF 3546) NTS

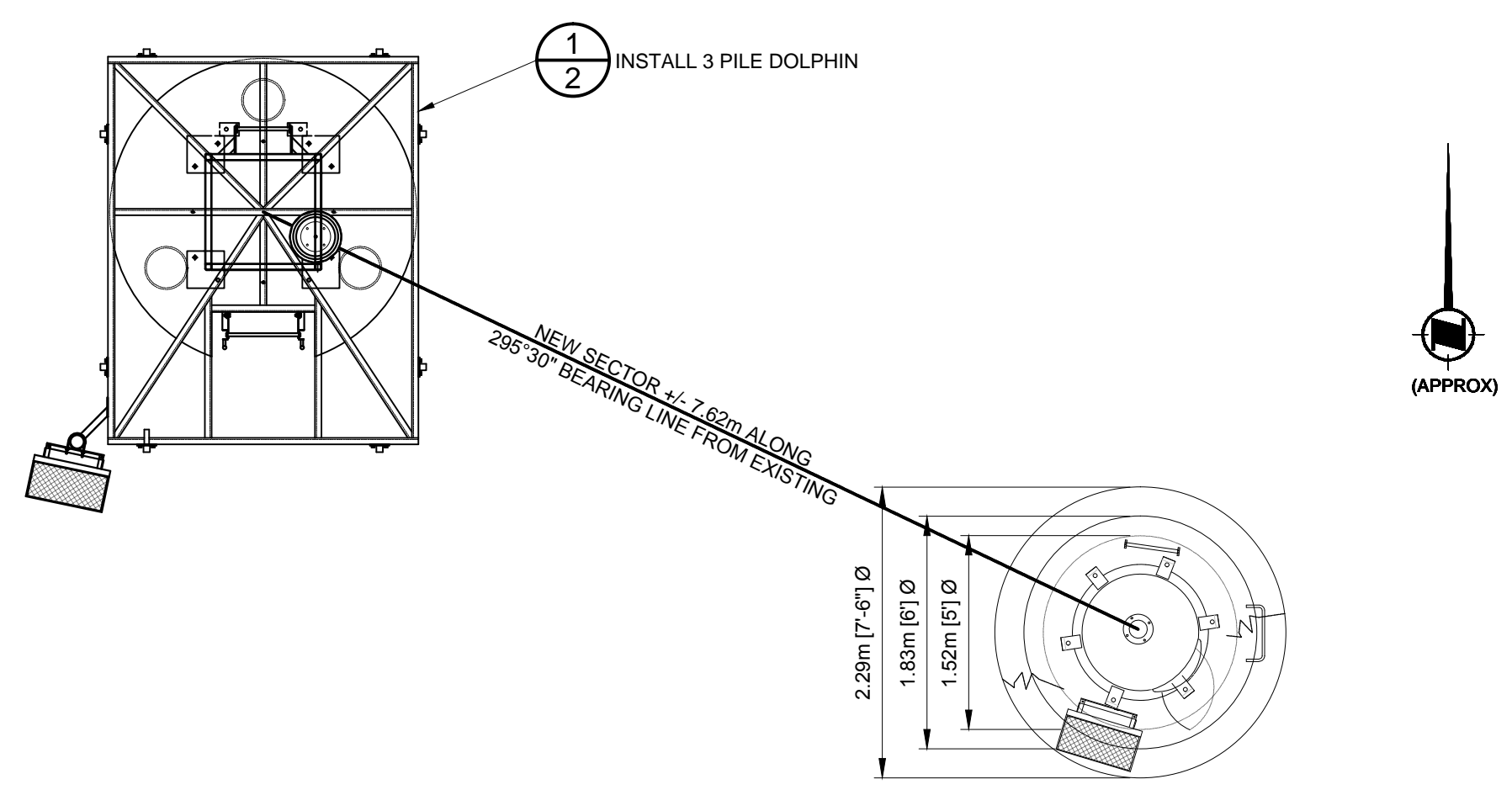

PLAN

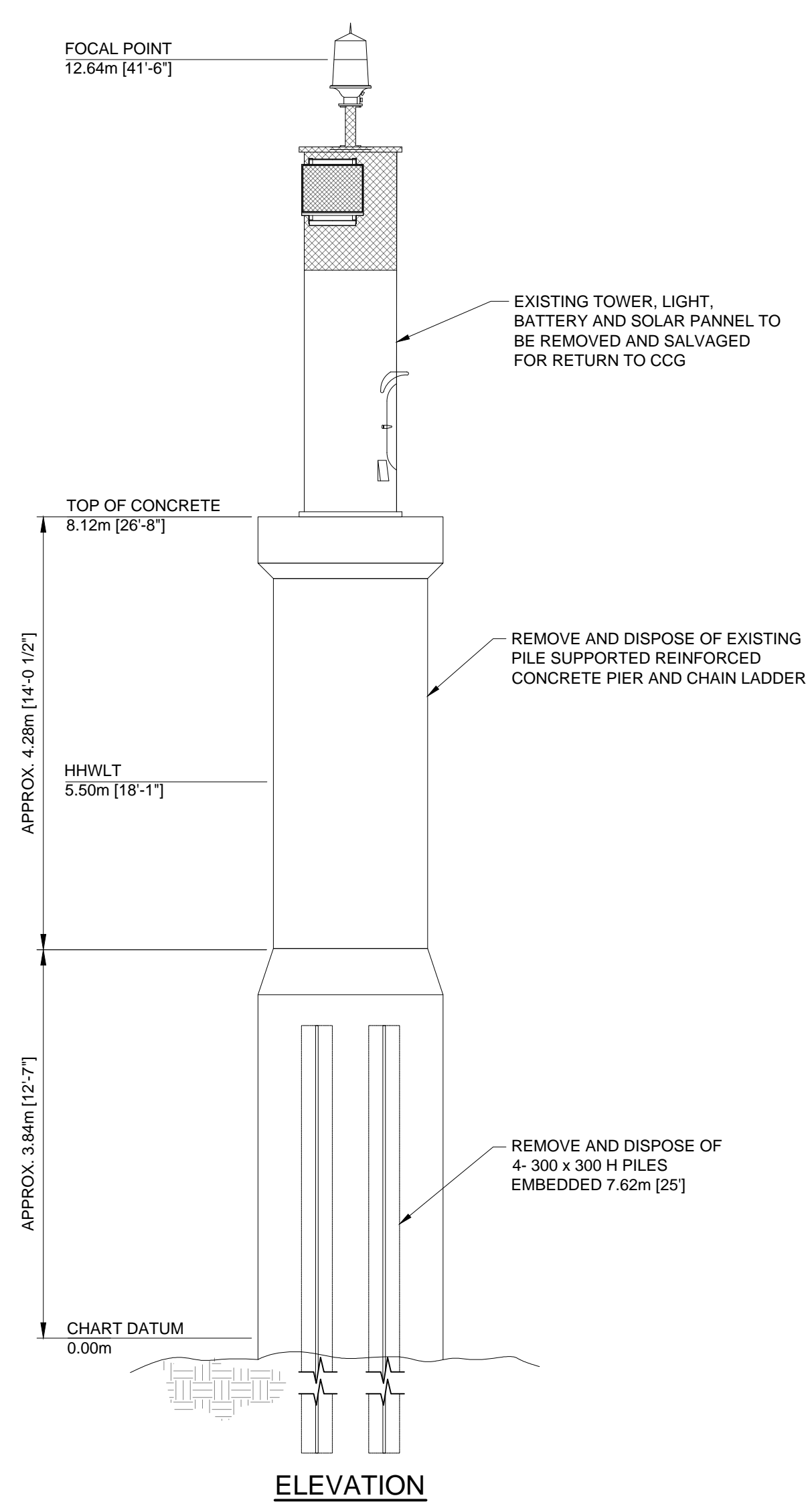

ELEVATION

EXISTING **A** 2.65m FRP TOWER
SCALE: 1:50



YELLOW BLUFF SECTOR APRIL 2015

SECTOR LIGHT

FROM	TO	COLOUR
289°	302°	RED
302°	289°	WHITE



AERIAL PHOTO

B	FOR TENDER	BT	2015.11.30
rev	description	by	date
Asset - Actif			
LL 549.2 YELLOW BLUFF SECTOR NAV-AID REBUILD			
Drawing - Dessin			
REMOVE AND REPLACE EXISTING AID TO NAVIGATION			
drawn - dessiné	date		
BT	2015.10.31		
designed - conception	date		
checked - vérifié	date		
approved - approuvé	date		
PG	2015.11.30		
CCG ref. no. - no. ref. GCC	scale - échelle		
A6170	AS NOTED		
drawing no. - no. dessin	sheet-feuille	rev-rév	
23816	01/03	B	

D
C
B
A

GENERAL NOTES

1. THESE STRUCTURAL DRAWINGS ARE TO BE READ IN CONJUNCTION WITH ALL OTHER APPLICABLE CONSTRUCTION DOCUMENTS. DEVIATION OF PROJECT CONSTRUCTION IS NOT ACCEPTABLE UNLESS INSTRUCTED BY THE ENGINEER.
2. ALL INFORMATION CONCERNING EXISTING SITE CONDITIONS HAVE BEEN TAKEN FROM ORIGINAL DRAWINGS AND SITE MEASUREMENTS. SHOULD INFORMATION OR SITE CONDITIONS DIFFER SIGNIFICANTLY FROM THAT SHOWN, ADVISE CCG ENGINEERING.
3. DO NOT COMMENCE CONSTRUCTION USING THESE DRAWINGS UNLESS NOTED "FOR CONSTRUCTION".
4. CONSTRUCTION SHALL BE IN ACCORDANCE WITH THE NATIONAL BUILDING CODE 2010 AND REFERENCED STANDARDS THEREIN.
5. DRAWINGS SHOW COMPLETED STRUCTURES ONLY. CONTRACTOR IS RESPONSIBLE TO PROVIDE TEMPORARY STRUCTURES AND BRACING FOR CONSTRUCTION LOADING CONDITIONS AND STABILITY OF THE STRUCTURE DURING CONSTRUCTION. CONSTRUCTION LOADS SHALL NOT EXCEED THE DESIGN LOADS.
6. IT IS THE DISCRETION OF THE ENGINEER TO CONDUCT INSPECTIONS OR ACCEPT PHOTOS OF REINFORCING PRIOR TO THE PLACEMENT OF CONCRETE.

STRUCTURAL STEEL

1. SUPPLY, FABRICATION, ERECTION, STRUCTURAL DESIGN AND DETAILING OF ALL STRUCTURAL STEEL SHALL BE IN ACCORDANCE WITH CAN/CSA-S16
2. ALL WELDING SHALL CONFORM TO CSA W59 AND SHALL BE PERFORMED BY FABRICATORS FULLY APPROVED BY THE CANADIAN WELDING BUREAU UNDER CSA W47.1 FOR DIVISION 2
3. STRUCTURAL STEEL SHALL CONFORM TO THE REQUIREMENTS OF THE FOLLOWING STANDARDS:
 1. CHANNELS, ANGLES AND PLATE: CAN/CSA-G40.21, GR. 300W
 2. HSS SECTIONS: CAN/CSA-G40.21, GR. 350W
 3. COLD FORMED METAL: CAN/CSA-S136
 4. STRUCTURAL BOLTS: ASTM-A325
 5. ANCHOR RODS: ASTM-A307 GALVANIZED OR ASTM A193 SS
4. ALL CONNECTIONS ARE TO BE DESIGNED BY THE FABRICATOR UNLESS OTHERWISE INDICATED ON THE DRAWINGS. CONNECTION DESIGN SHALL BE IN ACCORDANCE WITH THE SPECIFICATION.
5. BEAM CONNECTIONS SHALL BE STANDARD FRAME CONNECTIONS OR EQUAL PROPORTIONED FOR 60% OF THE VERTICAL SHEAR CORRESPONDING TO THE MAXIMUM UNIFORMLY DISTRIBUTED LOAD CAPACITY OF THE BEAM.
6. STRUCTURAL STEEL SHOP DRAWINGS SHALL BE REVIEWED PRIOR TO FABRICATION. SUBMIT 4 COPIES OF SIGNED AND SEALED BY A PROFESSIONAL ENGINEER REGISTERED IN THE PROVINCE OF BRITISH COLUMBIA. THE CONTRACTOR SHALL BE RESPONSIBLE FOR ALL DIMENSIONS AND FIT-UP OF ALL COMPONENTS.
7. BOLTS SHALL BE 3/4" DIAMETER AND BE DESIGNED FOR THREAD INCLUDED BEARING TYPE CONNECTION U.N.O.
8. GRIND ALL WELDS AND EDGES SMOOTH AS REQUIRED
9. HOT DIP GALVANIZING TO A123M MIN COATING 600g/m².
10. ALL TOUCH UP AND FIELD WELDS TO BE CLEANED AND PAINTED WITH ZINC RICH COLD GALVANIZING TO A780M.

rev	description	by	date
B	FOR TENDER	BT	2015.11.30

LL 549.2 YELLOW BLUFF SECTOR NAV-AID REBUILD

3-PILE DOLPHIN

drawn - dessiné	date
BT	2015.10.31
designed - conception	date
checked - vérifié	date
approved - approuvé	date
PG	2015.11.30
CCG ref. no. - no. ref. GCC	scale - échelle
A6170	AS NOTED
drawing no. - no. dessin	sheet-feuille
23816	02/03 B

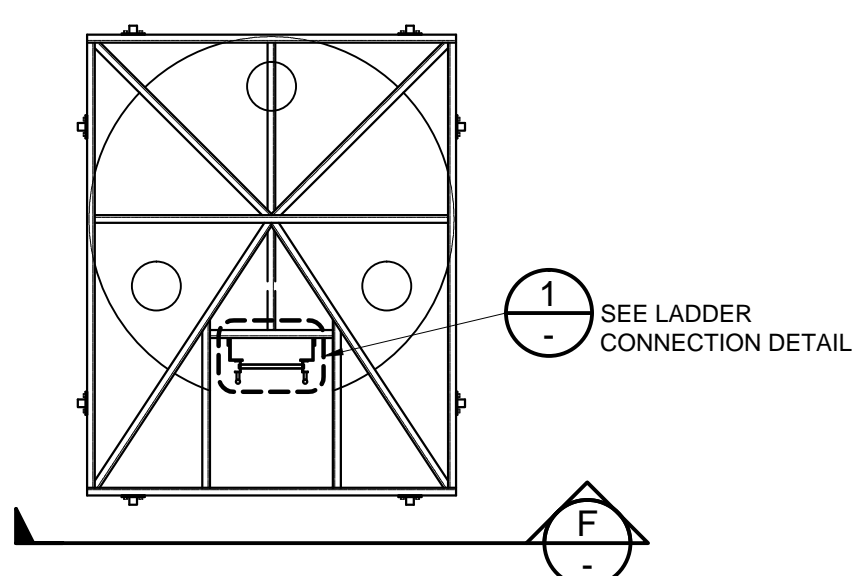
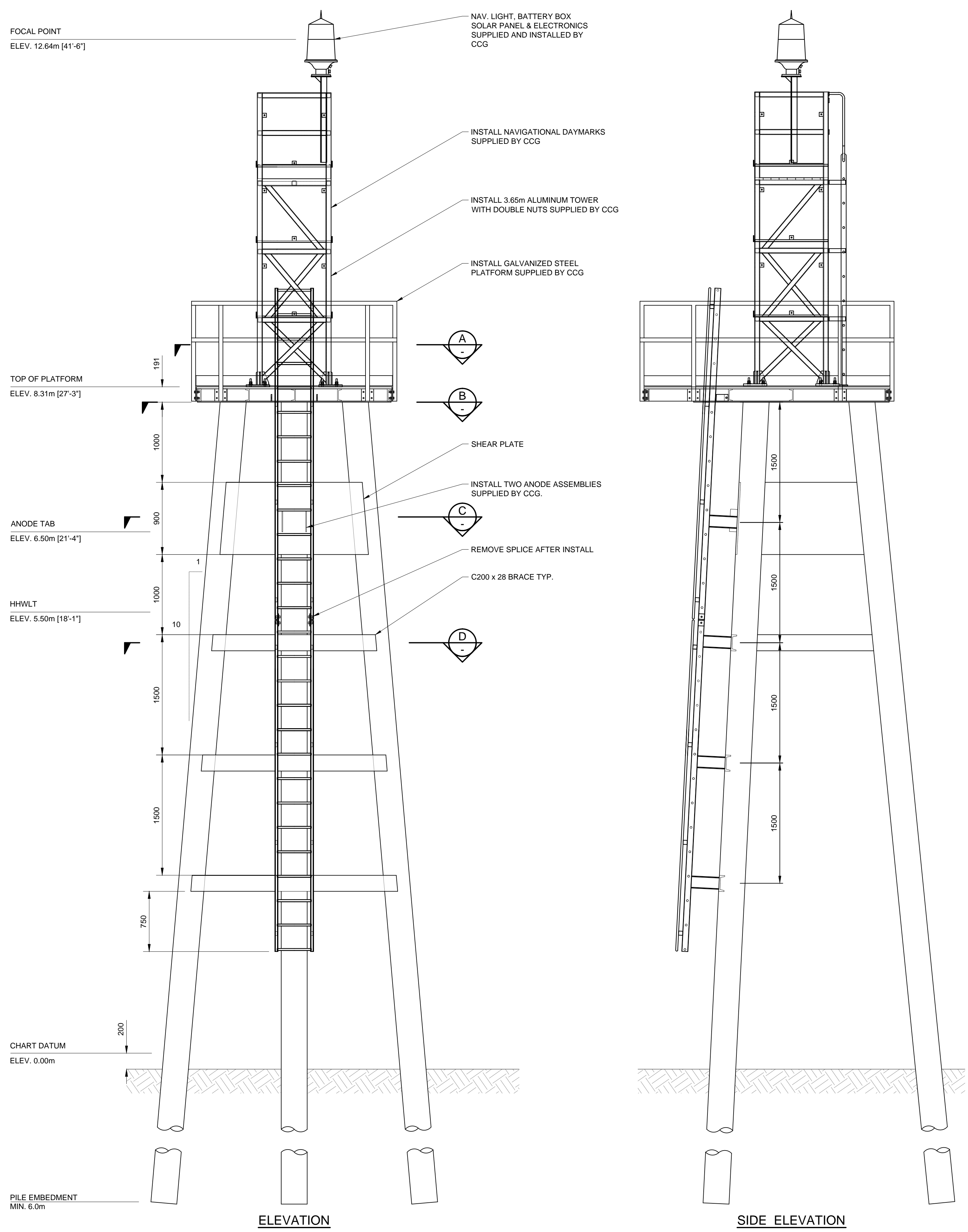

SECTION A
SCALE: 1:50

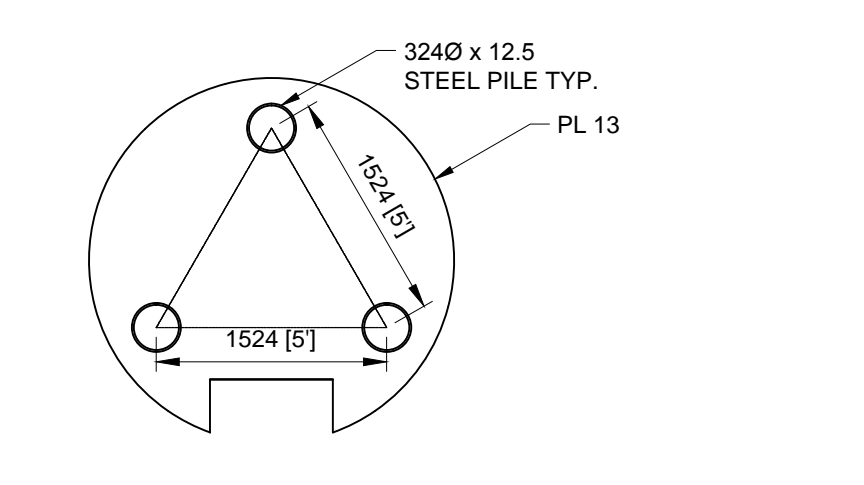

SECTION B
SCALE: 1:50

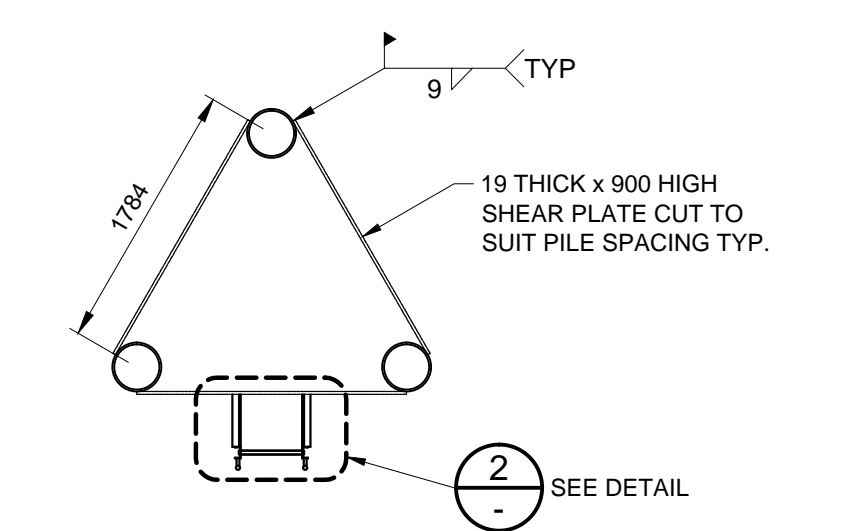

SECTION C
SCALE: 1:50

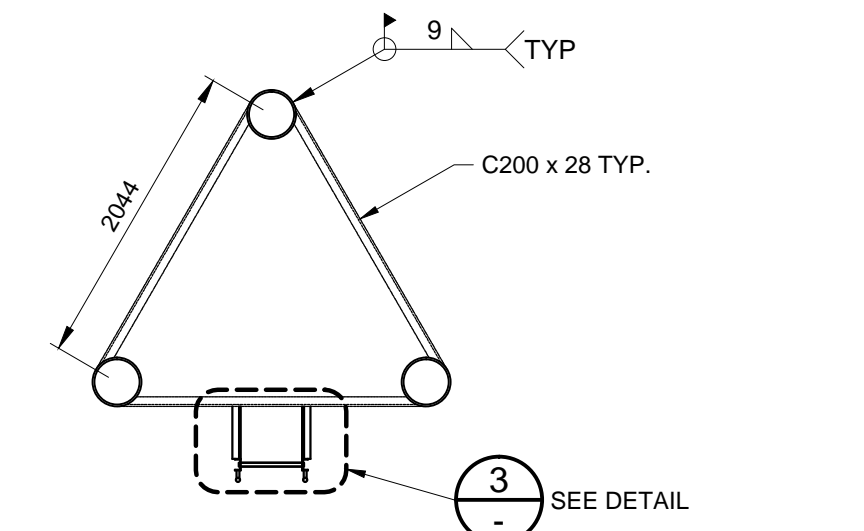

SECTION D
SCALE: 1:50

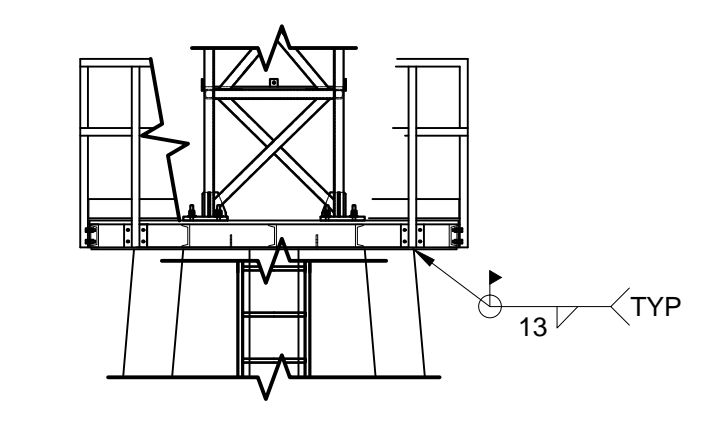

SECTION F
SCALE: 1:50

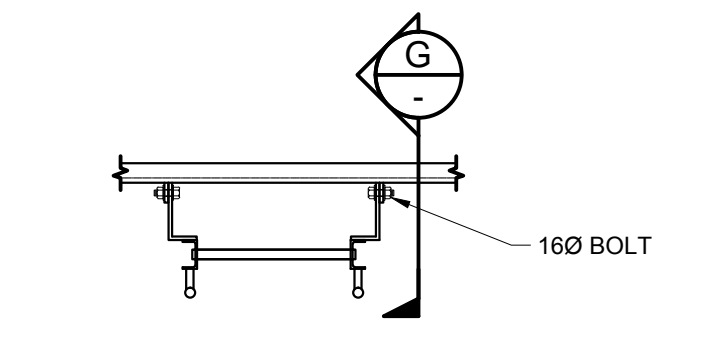

SECTION G
SCALE: 1:20

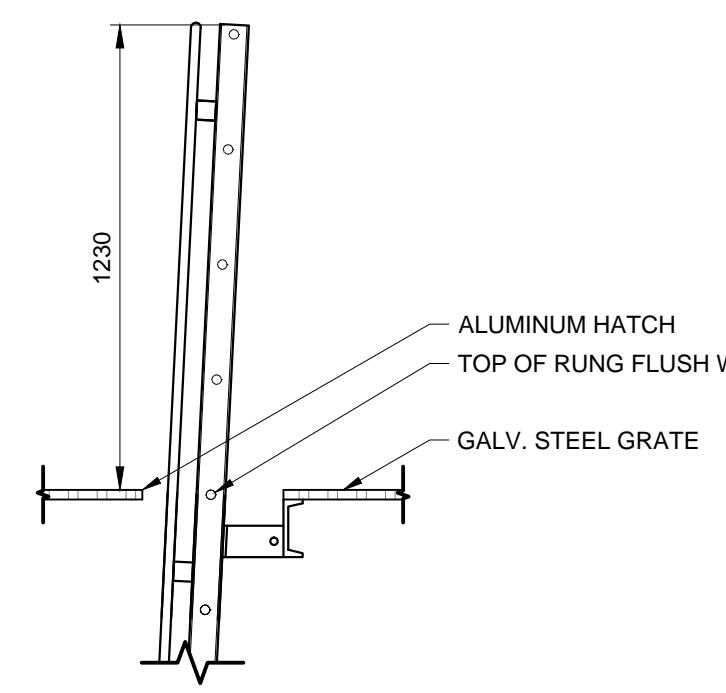

DETAIL 1
SCALE: 1:20

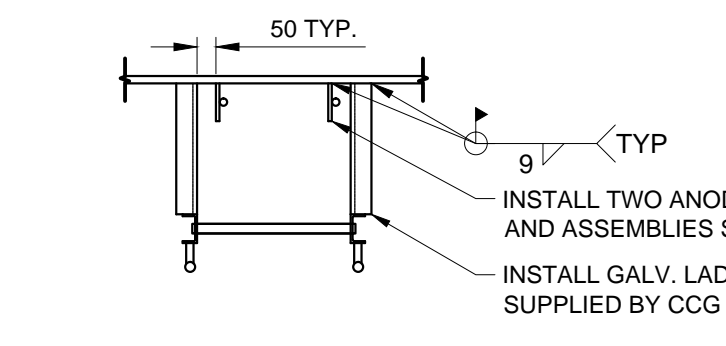

DETAIL 2
SCALE: 1:20

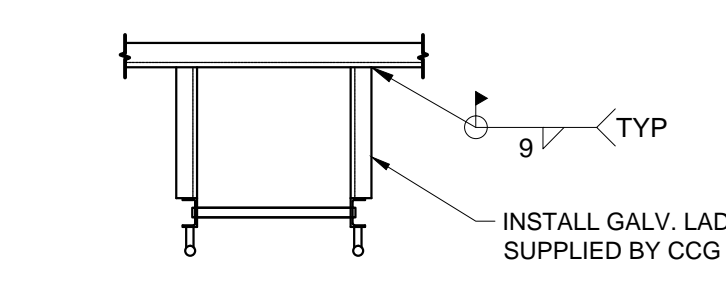

DETAIL 3
SCALE: 1:20

PROPOSED 1 NAVIGATIONAL AID
SCALE: 1:30

SIDE ELEVATION

ELEVATION

0 1 inches 3 4 pouces

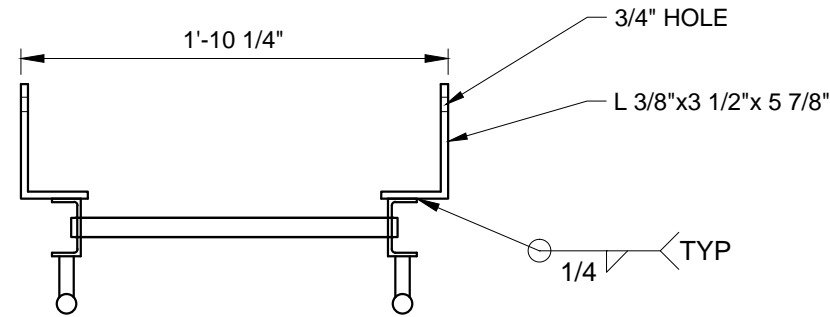

UPPER MOUNT

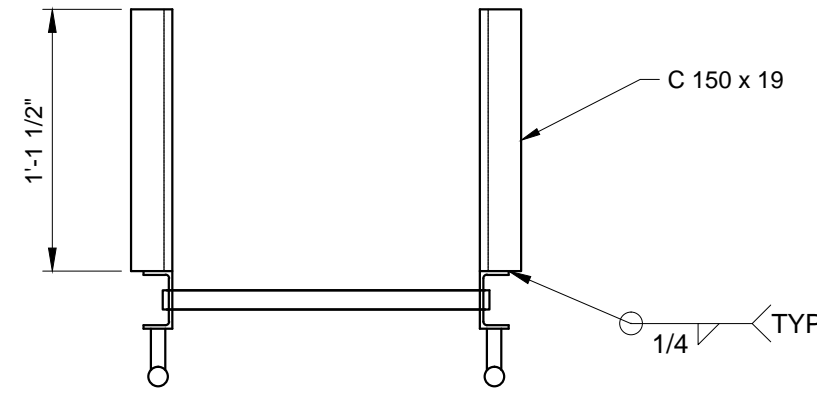

MOUNT TAB TYP.

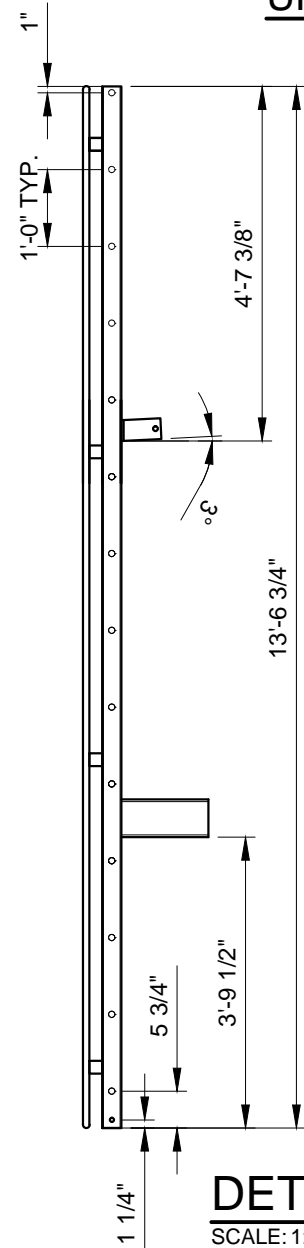
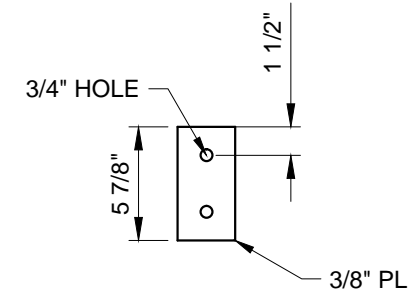

DETAIL 1 UPPER LADDER

SCALE: 1:30

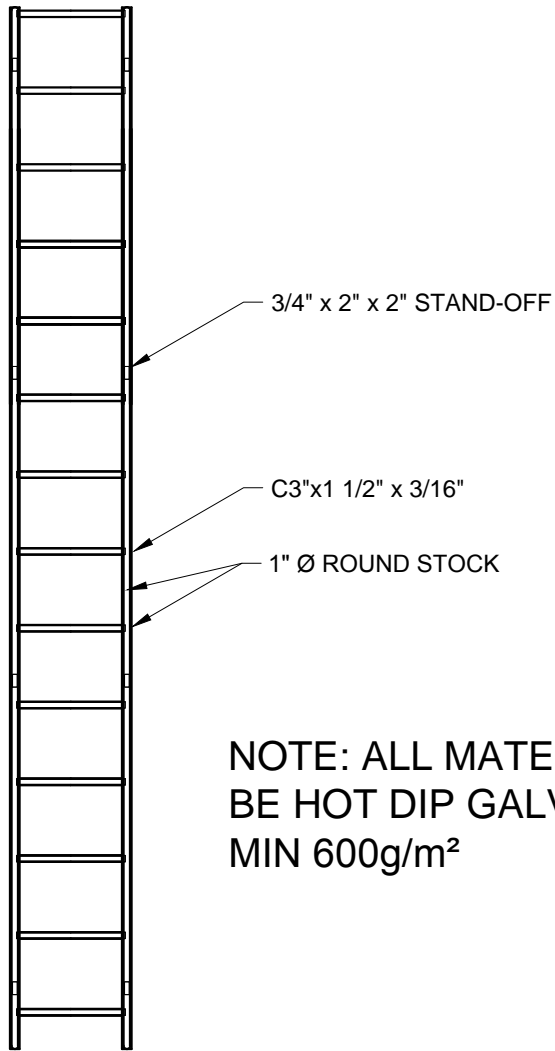

NOTE: ALL MATERIAL TO BE HOT DIP GALVANIZED MIN 600g/m²

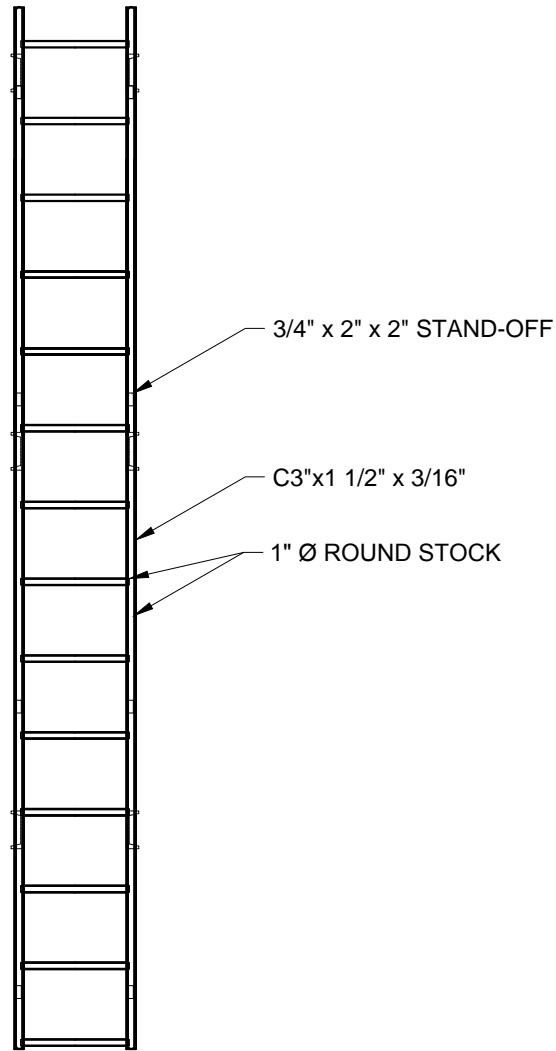

DETAIL 2 LOWER LADDER

SCALE: 1:30

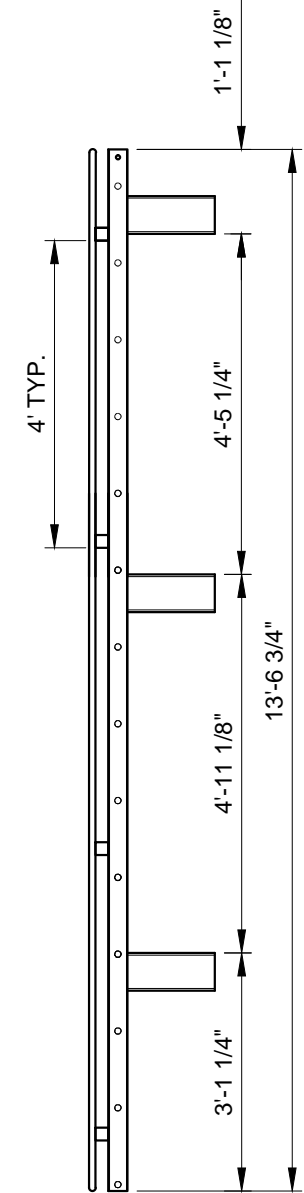

Fisheries and Oceans Canada
Pêches et Océans Canada
Canadian Coast Guard
Garde côtière Canadienne

designed - conception	date	checked - vérifié	date
drawn - dessiné	date	approved - approuvé	date
BT	2015.11.10	B	FOR TENDER
CCG ref. no. - no. réf. GCC	scale - échelle	rev	description
A6170	AS NOTED		

Asset - Actif	by par	Date
LL 549.2 YELLOW BLUFF SECTOR	BT	2015.11.30
NAV-AID REBUILD		

LL 549.2 YELLOW BLUFF SECTOR
NAV-AID REBUILD

Drawing - Dessin
CCG SUPPLIED
GALV. LADDER FABRICATION

drawing no. - no. dessin	sheet-feuille	rev
23816	03/03	B

23816

4

3

0 1 2 3 4 5 6 7 8 millimeters

2

1

23816

File / Fichier: 23816 LL549.2 YELLOW BLUFF SECTOR.DWG - Printed / Imprimé: 2015/11/30 8:52

ANSI B



Fisheries and Oceans
Canada

Pêches et Océans
Canada

Canadian
Coast Guard

Garde côtière
canadienne

APPENDIX B2 – SUMMARY OF SUBMITTALS

Following Contract Award	
Submission Description	Section(s)
Deadline: 10 working days following award	
Detailed schedule:	011100
Proof of qualifications:	
a) Proof of CWB Div. 3 Certification	011100
b) Proof of Vessel Registration	011100
Deadline: 10 working days prior to mobilization	
Construction Plan;	
a) Project specific safety plan	013530
b) Project environmental protection plan	013543
c) Detailed demolition plan	024116
d) Detailed erection plan	055000
e) Detailed pile driving plan	316113
Deadline: 21 calendar days following acceptance of the works	
Waste disposal receipts	024116



Fisheries and Oceans
Canada

Pêches et Océans
Canada

Canadian
Coast Guard

Garde côtière
canadienne

APPENDIX B3 – Marine Access Requirements

.1 Marine Access

- .1 Vessel(s) employed in the performance of the contract shall be certified as required by the Canada Shipping Act 2001 and its applicable regulations including Marine Personnel Regulation.
- .1 The bidder shall ensure that the vessel(s) proposed for the work meets all requirements of the Canada Shipping Act 2001 and the applicable Regulations under the Canada Shipping Act.
- .2 Bidders shall provide copies of the following documentation to facilitate evaluation and award:
 - .1 Proof of vessel registration as a commercial vessel in accordance with the Canada Shipping Act 2001. Either one of two registrations will be accepted:
 - .1 Proof of commercial vessel registration in the Small Vessel Register (SVR) if less than 15 Gross Tons or;
 - .2 Proof of commercial vessel registration in the Canadian Register of Vessels (CRV) if more than 15 Gross Tons.
 - .3 NOTE: Pleasure Craft and Fishing Vessels are not acceptable for the performance of this work – it must be a commercially registered vessel.
 - .2 Where the vessel is registered in the SVR the bidder shall also provide the following:
 - .1 Copy of vessel certification and any limitations the vessel is operating under. Where the vessel is restricted, the operator shall ensure that the vessel can be used to safely perform the work in this specification;
 - .2 Copy of inspection according to the Small Vessel Compliance Program; Bidder shall submit proof of enrolment in the compliance program and;
 - .3 Either a copy of the initial inspection report or the most recent copy of an annual inspection report and;
 - .4 Copy of the crew certification that will be operating the vessel. Crewing and certification of crew shall be in accordance with the Marine Personnel Regulations, latest edition.
 - .3 Where the vessel is registered in the CRV the bidder shall also provide the following:
 - .1 Copy of the latest Annual Inspection Certificate endorsement and;

- .2 Copy of any restrictions that the vessel is operating under and the general sailing limitations of the vessel. Where the vessel is restricted, the operator shall ensure that the vessel can be used to safely perform the work in this specification;
 - .3 Copies of the crew certification that will be operating the vessel. Crewing and certification of crew shall be in accordance with the Marine Personnel Regulations, latest edition.
- .2 Vessels and crew found to be in contravention of the act will not be permitted to be engaged in any elements of the works identified herein. In the event that a vessel or crew is found non compliant a suitable replacement vessel and/or crew will be retained by the Contractor at their sole expense.



Fisheries and Oceans
Canada

Pêches et Océans
Canada

Canadian
Coast Guard

Garde côtière
canadienne

APPENDIX B4 – Environmental Review

Environmental Review – LL 549.2 Yellow Bluff Sector Navigational Aid 2015

At the request of Canadian Coast Guard (CCG), Environmental Services Directorate of Public Works and Government Services Canada (PWGSC) has conducted a review of the maintenance and repair of the LL 549.2 Yellow Bluff Sector navigational aid structure to determine whether there will be any risk of significant adverse environmental effects.

Scope of Work

DFO-CCG proposes to repair and replace structures of the LL 549.2 Yellow Bluff Sector navigational aid. Construction details are provided in the attached drawings. Work consists of replacing the existing concrete base with a mono pile or 3 pile dolphin, refurbish the tower, attach a standard aluminum access ladder with handgrabs, and add an 8 ft by 10 ft standard platform.

Working crews will access the project sites by a CCG vessel which has a working platform. All works will be conducted so that no deleterious materials or otherwise will enter the marine environment and the vessel will not ground.

Note that several environmental studies have been completed for the site:

Species Assessment for Minor Shore Lights Coastal BC, Hemmer Envirochem, March 2009

Modified Phase 1 Environmental Site Assessment Yellow Bluff Sector Navigational Aid Site LL 549.2 PK00758, SNC Lavalin, Feb. 15 2012

Environmental Site Assessment and Remediation at Priority Navigational Aid Sites in British Columbia Yellow Bluff Sector Navigational Aid Site PK 00758, SNC-Lavalin, July 28, 2014

Project Location

LL 549.2 Yellow Bluff Sector navigational aid is located at yellow Bluff on a cobble beach off the southwest end of Cormorant Island at the entrance to Alert Bay. Exact location is shown on the attached drawings.

Latitude: 50.586889
Longitude: – 126.950861

Estimated dimension: 1.5 m by 1.5 m

The aid is located on unsurveyed foreshore situated within the Broughton Strait. It is not located on federal lands, in a wildlife area, migratory bird sanctuary, or provincial/national park.

Contaminated Sites

Canadian Coast Guard has completed two site assessments for Yellow Bluff, SNC Lavalin 2012 and 2014. The 2012 report indicated two potential contaminants of concern: metals from battery use and metals from painted surfaces. Further assessment was recommended to review the potential for impact to the aquatic environment due to metals from the battery. The 2014 assessment examined in further detail the potential for metal contamination and indicated that no further action was required.

Recommendation: Note that the previous studies do not indicate that a battery was disposed of at the Yellow Bluff site – only that there is potential for battery disposal at minor shore light locations. Should a battery be uncovered during this project; stop work and consult the environmental monitor. The environmental monitor should be familiar with previous site assessments and their recommendations. It is recommended to contact DFO Real Property contaminated sites specialists prior to conducting the work to get direction on what should be done if a battery is uncovered at this site.

Species at Risk

The 2009 Hemmera species assessment indicated that three species may be present on the Pacific coast that utilize marine substrates: northern abalone (*Haliotis kamtschatkana*), leatherback turtle (*Dermochelys coriacea*) and Olympia oyster (*Ostrea conchaphilia*).

Northern abalone is listed as Sch. 1 Endangered on the federal Species at Risk Act (SARA) and red listed provincially. A Recovery Strategy was developed followed by an Action Plan in 2012. The Action Plan identified 4 areas of critical habitat on the westcoast. Substrate favoured by the abalone is bedrock or boulders or cobbles with adequate roughness for ease of attachment; at a depth of less than or equal to 10 metres; with the presence of encrusting coralline algae and other macroalgae and moderate to high tidal current or wave action.

Yellow bluff sector navigational aid does not fall within any of the areas of critical habitat. Based on a habitat assessment that was conducted as a component of the 2014 SNC Lavalin assessment the substrate at Yellow Bluff was considered unsuitable for the northern abalone due to a lack of boulders and bedrock and the presence of soft sediment.

Leatherback turtles are listed as Sch. 1 Endangered in the SARA and red listed provincially. Rarely sighted on the westcoast, they are migratory with most of their time spent in open water and breeding in tropical regions on beaches with little abrasive material. Given these preferences the turtle was deemed not likely present at Yellow Bluff.

Olympia oysters are listed as Sch. 1 Special Concern on the SARA and blue listed provincially. Olympia oysters are primarily found in the lower intertidal and subtidal zones of estuaries and saltwater lagoons and are also found in other marine zones up to a 50m depth. They may be found attached to pilings or the undersides of floats. They require a hard surface for attachment. Based on the habitat assessment conducted by SNC Lavalin 2014 the Olympia oyster was not likely to be present at the site.

In addition to a review of the previous assessments, a review of the current species database was undertaken using the BC Species and Ecosystem Explorer. The review identified that in addition to the northern abalone and several bird species the grey whale and the stellar sea lion may be present in the area although they are transient. Both are blue listed provincially and are Sch. 1 Special Concern federally.

Recommendation: Current project design and construction methods with appropriate mitigation will ensure no serious harm.

Migratory Birds

There will be no impact on migratory birds. No nests have been identified on the structures and the work is being conducted outside the nesting season. **Recommendation:** no action

Archaeology / Heritage

Excavations of soil are not a component of the project however there are two archaeological / heritage sites located within Alert Bay, EdSr-7 and EdSr-6. Any works conducted in the intertidal have potential for uncovering archaeological resources. Disturbance due to this project is expected to be limited to the footprint of the existing structure.

Recommendation: The site supervisor and the environmental monitor must have an awareness of archaeological / heritage resources and should any resources be noted during the project work should stop immediately and an archaeologist brought in to review the work in partnership with the local First Nation.

Water Act

The Water Act does not apply to the marine environment. **Recommendation:** no further action.

Fisheries Act

A self-assessment was completed on the project and it was determined that no Fisheries Act review was required. Examining the self-assessment tool on the DFO website the structures themselves and the scope of work is most similar to works listed under the harbours and marine commercial activities section. In fact the scope of work is much smaller than many of the listed activities that are excluded for review. Based on this, the results of the previous habitat assessments and the review for species at risk, and the considerations listed below in the Restrictions section it was determined no DFO review was required and there is low potential for serious harm.

The SNC Lavalin 2014 underwater survey indicated that there were instances of eelgrass, bull kelp, sea lettuce and star fish in proximity to the navigational aid.

Recommendation: apply standard mitigation for works in and about water. Ensure no grounding of the vessel. If grounding becomes imperative conduct a visual inspection first to ensure no grounding occurs on eel grass.

CEAA

The proposed works are not described in the *Regulations Designating Physical Activities* under CEAA 2012, therefore, an Environmental Assessment is not required for this work. The proposed project does not occur on federal land therefore a review for significant effects is not required under Sections 67-73. **Recommendation:** no action

Restrictions

Anticipated construction dates will be within the fisheries work window from November 15th 2015 to February 15 2016.

Fisheries timing windows indicate that period of time where there is the least risk of impact to fish and fish habitat.

Mitigation Measures

Standard mitigation practices and waste management procedures are to be followed throughout the construction process; see attached.

An environmental monitor should be present for the base removal and installation of the mono pile or dolphin structure.

Conclusion

Based on this review, it has been determined that the project, as proposed, poses a low risk of causing serious harm or significant impacts to fish and fish habitat or other environmental aspects. Adhere to the recommendations in this report and to the mitigation measures outlined in the attached document.

Katrina Johnston

Sr. Environmental Specialist
Public Works and Government Services Canada
401-1230 Government St
Victoria, BC V8W 3X4
250-363-8623

October 9, 2015

Standard Best Management Practices for Navigational Aid Maintenance and Repair Canadian Coast Guard

PROJECT ACTIVITY	MITIGATION
<p>GENERAL (to be incorporated into all activities below)</p>	<ol style="list-style-type: none"> 1. Ensure all personnel involved with activities are adequately trained and utilize appropriate personal protective equipment. 2. Storage of fuels and petroleum products will comply with safe operating procedures, including containment facilities in case of a spill. 3. Waste or any miscellaneous unused materials will be recovered for either disposal in a designated facility or placed in storage. Under no circumstances will materials be deliberately thrown into the marine or terrestrial environment. 4. Onsite crews will have emergency spill kit and equipment available. 5. All activities should be completed in such a way as to minimize stress and disturbance to resident flora and fauna. 6. Operations should only operate where entirely necessary to complete the works to reduce effects to nearby soils, vegetation, and resident species. Respect should be given to the natural environment to minimize the footprint of the project. 7. Aesthetic effects created by activities will be short-term and localized. Sites should be kept in a tidy manner during activities and left in a good condition at the end of the project. 8. Archaeological sites in remote locations are not likely to have been previously identified. Care should be taken to observe archaeological deposits while work is being completed. Work must be stopped if evidence shows a potential archaeological artifact or deposit.
<p>MACHINERY OPERATION</p>	<ol style="list-style-type: none"> 1. All equipment will be maintained in proper running order to prevent leaking or spilling of potentially hazardous or toxic products. This includes hydraulic fluid, diesel, gasoline and other petroleum products. 2. Vehicles should not be operated below the line of Highest High Water in the intertidal zone. 3. Operations should only operate where entirely necessary to complete the works to reduce effects to nearby soils, vegetation, and resident species. Respect should be given to the natural environment to minimize the footprint of the project. 4. Machinery must be operated efficiently, to ensure that noise and air quality issues are short-term and local.
<p>POWER-WASHING</p>	<ol style="list-style-type: none"> 1. Activities should be completed in such a way as to minimize the amount of fines and organic debris that may enter nearby aquatic environments.
<p>EXCAVATION/ROCK DRILLING</p>	<ol style="list-style-type: none"> 1. Rock drilling and excavation activities must be conducted conservatively so that physical changes to rock remain small and localized. 2. Dust and fines entering the water must be avoided.

Standard Best Management Practices for Navigational Aid Maintenance and Repair Canadian Coast Guard

PROJECT ACTIVITY	MITIGATION
EXCAVATION/ROCK DRILLING continued	<ol style="list-style-type: none"> 3. Archeological sites in remote locations are not likely to have been previously identified. Care should be taken to observe archaeological deposits while work is being completed. Work must be stopped if evidence shows a potential archaeological artifact or deposit. 4. Loose material at excavation sites should be managed to avoid excessive migration of silt and debris to nearby waters, especially during heavy rainfall events. 5. All excavation below Highest High Water should be completed by hand, as no vehicles should be operated in the intertidal zone. 6. Any blasting will follow the Guidelines for the Use of Explosives In or Near Canadian Fisheries Waters.
PILE INSTALLATION	<ol style="list-style-type: none"> 1. All equipment will be maintained in proper running order to prevent leaking or spilling of potentially hazardous or toxic products. This includes hydraulic fluid, diesel, gasoline and other petroleum products. 2. Contractors where possible will position their water borne equipment in a manner that will minimize damage to identified fish habitat (e.g. eel grass). Where possible, alternative methods will be employed (e.g. use of anchors instead of spuds). 3. Proper notice should be given to transportation authorities to warn of potential disruptions to navigability during works. 4. Whenever Contractors are working in areas where spawning is present, appropriate monitoring by a qualified person will be undertaken and activities ceased if spawn disruption is apparent. 5. Where possible, new timber piles will comply with the BMP for the use of treated wood in aquatic environments as developed by the Canadian Institute of Treated Wood and the Western Wood Preservers Institute. 6. Where the BMP pilings are not available, creosote piling will stand for a minimum of 45 days prior to installation. These requirements are for new pilings only and will not restrict the use of re-used timber pilings. Reused pilings will not be subject to any additional treatments. 7. If pile installation activities are causing fish kill, work must cease immediately and contractors will be responsible for introducing effective means of reducing the level of shock waves or introduce measures that will protect fish from entering the potentially harmful shock wave area. For example, appropriate mitigating measures would include the deployment a bubble curtain over the full length of the wetted pile that would defuse the shock waves to an acceptable level. 8. If, after preventive measures are introduced, visual monitoring reveals unacceptable conditions (fish kill), then work will stop immediately and the system reviewed and corrected. 9. Any instances of fish kill must be reported to the appropriate agencies (DFO).

Standard Best Management Practices for Navigational Aid Maintenance and Repair Canadian Coast Guard

PROJECT ACTIVITY	MITIGATION
	<ol style="list-style-type: none"> When cleaning out pipe piles (i.e. air lifting), if the material that is to be removed inside the pipe is non-toxic, then it shall be redistributed in a manner that will minimize damage to the surrounding aquatic fish habitat.
CONCRETE WORKS	<ol style="list-style-type: none"> When pouring concrete all spills of fresh concrete must be prevented. If concrete is discharged from the transit mixer directly to the form work or placed by wheelbarrow, proper sealed chutes must be constructed to avoid spillage. If the concrete is being placed with a concrete pump, all hose and pipe connections must be sealed and locked properly to ensure the lines will not leak or uncouple. Crews will ensure that concrete forms are not filled to overflowing. All concrete forms will be constructed and sealed in a manner which will prevent fresh concrete or cement laden water from leaking into the surrounding water. All tools, pumps, pipes, hoses and trucks used for finishing, placing or transporting fresh concrete must be washed off in such a way as to prevent the wash off water from entering the marine environment.
SITE ACCESS	<ol style="list-style-type: none"> Site access practices must be undertaken with regard to resident flora and fauna, especially during times of the year when they are most sensitive.
AID MAINTENANCE	<ol style="list-style-type: none"> Equipment maintenance activities must be completed in a manner that prevents the deposit of foreign materials to the environment. Power washing activities must follow mitigation provided under “POWER-WASHING” An approach of “contain and recover” should be adopted. Drop sheets or other means should be used to prevent paint chips and other debris from entering the surrounding environment. Refuse should be disposed of properly. Painting activities should be completed in such a way as to minimize the amount of fumes that may enter the environment. The amount of paint used should be minimized and unused containers must be covered.
PILE REMOVAL	<ol style="list-style-type: none"> Contractors will position their water borne equipment in a manner that will minimize damage to identified fish habitat (e.g. eel grass). Where possible, alternative methods will be employed (e.g. use of anchors instead of spuds). When demolition is required on timber pile structures, the contractor will remove the piling by mechanical means and avoid breaking the piling at the mud line or below. All demolition operations should be monitored in order to control and contain the construction debris.
CONCRETE BASE REMOVAL	<ol style="list-style-type: none"> Contractors where possible will position their water borne equipment in a manner that will minimize damage to identified fish habitat (e.g. eel grass). Where possible, alternative methods will be employed (e.g. use of anchors instead of spuds). All debris deposited throughout the life of the aid should be removed from the site.

**Standard Best Management Practices for Navigational Aid Maintenance and Repair
Canadian Coast Guard**

PROJECT ACTIVITY	MITIGATION
CONCRETE BASE ABANDONMENT	1. Care should be taken to remove all components of the Fixed Aid that are not incorporated into the concrete base. 2. All debris deposited throughout the life of the aid should be removed from the site. 3. Areas near the base should be protected from excessive disturbance. 4. Concrete base abandonment will be conducted only in remote sites, where aesthetic effects are not a concern.
CONCRETE BASE ABANDONMENT continued	



Fisheries and Oceans
Canada

Pêches et Océans
Canada

Canadian
Coast Guard

Garde côtière
canadienne

APPENDIX B5 – Standard Practices Pile Driving

Best Management Practices for Pile Driving and Related Operations

BC Marine and Pile Driving Contractors Association

March 2003

The B.C. Marine and Pile Driving Contractors Association and Fisheries and Oceans Canada have developed a Best Management Practices Policy for pile driving operations and related activities when working on the water within the province of British Columbia.

The Pile Driving Industry utilizes many different construction methods, equipment and materials in order to complete the contractual obligations for its client. Hammers; including drop, diesel, air, vibratory and hydraulic, vibroflot, and rotary, air and churn drills are the primary instruments in a pile driving operation. These hammers and drills are supported by a wide variety of heavy equipment, including a range of conventional cranes (truck mounted, crawler and pedestal mounted), spud scows, support barges and other water borne equipment. The piling types include treated timber (primarily creosote), concrete and steel (pipe, h-beam and sheet). Construction projects have the potential to utilize a number of different combinations of equipment and materials. It is the purpose of this document to examine the characteristics of each potential combination and develop a Best Management Practices Policy that will meet the following criteria:

- Maximize environmental protection
- Adhere to the Fisheries and Oceans regulations
- Provide construction services economically

1)- Basic Rules of Operation

When in an aquatic environment, contractors will employ the following BASIC Best Management Practices:

- All equipment will be maintained in good proper running order to prevent leaking or spilling of potentially hazardous or toxic products. This includes hydraulic fluid, diesel, gasoline and other petroleum products.
- Storage of fuels and petroleum products will comply with safe operating procedures, including containment facilities in case of a spill.
- Pile cut offs, waste or any miscellaneous unused materials will be recovered for either disposal in a designated facility or placed in storage. Under no circumstances will materials be deliberately thrown overboard.
- Contractors will have emergency spill equipment available whenever working near or on the water.
- Contractors where possible will position their water borne equipment in a manner that will minimize damage to identified fish habitat (e.g. eel grass). Where possible, alternative methods will be employed (e.g. use of anchors instead of spuds). In the event that circumstances will not allow an alternative, contractors will minimize the damage and where required restore habitat to its original state at the completion of the project.

- Prior to the commencement any work that is longer than 5 working days in duration and falls under this agreement, the contractor will complete and forward the attached “Notice of Project” to the Department of Fisheries.
- Whenever Contractors are working in areas where spawning is present, the work will be temporarily suspended and the appropriate fisheries officer contacted.
- There will be no restriction of work during closure periods (with the only exception when spawning is present) provided the contractors employ an exclusion device around the work area to restrict fish access or when required an effective method of mitigating shock waves (bubble curtain).
- Whenever shock wave monitoring (hydro phone) is performed at a marine construction site and the findings are available to the contractor, the data will be forwarded to the B.C. Marine and Pile Driving Contractors Association. It is intended to build a data base of information so that work procedures will reflect the safest and most economical approach to protecting the fish and their habitat.

2)-Timber Piling (creosote):

When driving timber piling, the following Best Management Practices will be employed to ensure minimum impact to marine fish and their habitat:

- Where possible, new timber piles will comply with the best Management Practices for the use of treated wood in aquatic environments as developed by the Canadian Institute of Treated Wood and the Western Wood Preservers Institute.
- Where the above is not possible creosote piling will stand for a minimum of 45 days prior to installation.
- These requirements are for new piling only and will not restrict the use of re-used timber piling. Reused piling will not be subject to any additional treatments.
- Timber piling is normally driven using a drop hammer, a diesel/air impact hammer or a small vibratory hammer. Because of the relative small diameter of the timber pile, and its excellent energy absorbing quality, there is little threat to fish and their habitat when driving timber piles.
- No environmental monitoring is required.
- When demolition is required on timber pile structures, the contractor will remove the piling by mechanical means and avoid breaking the piling at the mud line or below. All demolition operations should be monitored in order to control and contain the construction debris.

3)-Concrete Piles

When driving concrete piles regardless of which hammer is being used, the following Best Management Practices will be employed to minimize the impact on fish habitat:

Up to 24 inch diameter concrete piling

- The physical design of 24 inch concrete pile dictates that one, the energy required must be controlled in order to prevent the pile from breaking and second the concrete construction of the pile will absorb the energy. These two factors result in low level shock waves (less than 30 kPa.) being emitted and are of no danger to fish and their habitat.
- No environmental monitoring is required.

Over 24 inch diameter concrete piling

- When driving concrete piles with a diameter greater than 24 inches using an impact or hydraulic hammer, the following Best Management Practice will be employed to minimize the impact on fish habitat:
- Visual monitoring of the impact on fish by the shock waves emitted will be required. If fish kill is evident then the contractor will introduce effective means of reducing the level of the shock waves. Appropriate mitigating measures would be the deployment of a bubble curtain over the full length of the wetted pile. This should defuse the shock waves to an acceptable level.
- If after the preventive measure is introduced, and further visual monitoring reveals unacceptable conditions (excessive fish kill), then the work will stop immediately and the system reviewed and corrected.

4)-Steel Pipe Piles (less than 24 inch in diameter):

When driving steel piles of less than 24 inches in diameter regardless of the type of hammer being used, the following Best Management Practices will be employed to minimize the impact on the fish habitat:

- Because of the small diameter of the pile it is an accepted principle that the energy required to drive the pile to final point of installation would not result in shock wave in excess of 30 kPa. , and therefore would not require protective measures from the possibility of shock waves.
- If due to the ground conditions, the pile installation is causing excessive fish kill work will cease and contractors will be responsible for introducing effective means of reducing the level of shock waves or introduce measures that will protect fish from entering the potentially harmful shock wave area. Appropriate mitigating measures would be the deployment a bubble curtain over the full length of the wetted pile that would defuse the shock waves to an acceptable level.
- If after preventive measures are introduced, and visual monitoring reveals unacceptable conditions (excessive fish kill), then the work will stop immediately and the system reviewed and corrected.

5)-Steel Pipe Piles (over 24 inches in diameter)

When driving steel pipe piles with a diameter greater than 24 inches using impact or hydraulic hammers, the following Best Management Practices will be employed to minimize the impact on fish habitat:

- Visual monitoring of the effects of the shock waves on fish habitat will be required. If fish kill is evident then the contractor will introduce effective means of reducing the level of the shock wave. Appropriate mitigating measures would be the deployment of a bubble curtain over the full length of the wetted pile. If after preventive measures are introduced, and further visual monitoring reveals unacceptable conditions (excessive fish kill), then the work will stop immediately and the system reviewed and corrected.

6)-Steel Sheet Piles and H-piles

When driving steel sheet piles and H-piles with a drop hammer, an impact hammer or a vibratory hammer the following Best Management Practices will be employed to minimize the impact on fish habitat:

- It is anticipated that the driving of these types of piles will not generate shock waves in excess of 30kPa., therefore the need for mitigating measures is not required.
- If due to ground conditions, the pile installation is causing excessive fish kill, work will cease and the contractor will be responsible for introducing an effective means of reducing the level of shock wave or introduce measures that will protect fish from entering the harmful shock wave area. Appropriate mitigating measures would be the deployment of a bubble curtain over the full length of the wetted pile that would defuse the shock waves to an acceptable level.
- If after preventive measures are introduced, and visual monitoring reveals unacceptable conditions (excessive fish kill), then the work will stop immediately and the system reviewed and corrected.

7)-Stone Column Construction

When installing stone column using a vibroflot the following Best Management practices will be employed to minimize the impact on fish habitat:

- The vibrating action and air flush associated with the operation of the probe results in a high degree of turbidity. When this level exceeds the criteria as outlined in the British Columbia Approved Water Quality Guidelines, the contractor will introduce containment method that are designed to isolate the contaminated area and to prevent fish from entering the contaminated area. Silt curtains and netting are two methods that can provide the necessary protection.
- When supplying the aggregate to the probe, the contractor will ensure that spillage is controlled thereby providing additional protection to the fish habitat.
- An independent environmental agency will be used to monitor the levels of turbidity.

8)-Underwater Drilling and Blasting

When performing underwater drilling and blasting the following Best Management Practices will be employed to minimize the impact on fish habitat:

Underwater Drilling

- Drilling underwater is a process that has very little impact on the fish habitat. The procedure does not generate shock waves.
- Contractors will ensure that all attachments (hydraulic connections and couplings) are in good operating order and inspected prior to the start of every day.
- Depending on soil conditions and the potential for turbidity, drill cuttings will be deposited adjacent to the operation, contained on the sea bed or deposited into containment skiffs or scows when it is determined that the drill cuttings are unsuitable for return to the environment.

Underwater Blasting

Contractors required to perform blasting underwater will provide the following protection:

- Because of the potential for a blasted shock wave, a protection shield will surround the immediate blast area. This would be in the form of an air-induced bubble curtain, which has the primary purpose of absorbing the shock wave and a secondary purpose of keeping fish from entering the blast area.
- In order to protect against flying rock, mats (rubber) will be placed over the blasting area. The placement of the mats will also provide protection for any fish caught in the immediate area.
- Monitoring of fish movement and concentrations will be performed to determine if fish herding or scaring techniques (seal bombs) can be utilized to reduce the presence of fish in the blast area.

9)-Cleaning out Pipe Piles:

When cleaning out pipe piles (i.e. air lifting) the following Best Management Practice will be employed to minimize the impact on fish habitat:

- If the material that is to be removed inside the pipe is non-toxic, then it shall be redistributed in a manner that will minimize damage to the surrounding fish habitat. This can be achieved by the following systems:
- The excavated material is pumped through a discharge tube and allowed to settle in the immediate area.
- The excavated material is pumped through a discharge tube and contained within an enclosure (silt curtain) in order to control the sediment.
- The excavated material is pumped through a discharge tube and additional flex hosing and redirected back to the base of the pile.
- If the material to be removed from the pipe is determined to be toxic, then it will be processed through an approved containment system and the unwanted material removed and disposed of accordingly.

10) Containment of Concrete Residue and Water Run Off

When placing concrete in form work over or in water, the following Best Management Practice will be employed to minimize the impact on fish habitat:

Pouring concrete

- Spills: When pouring concrete all spills of fresh concrete must be prevented. If concrete is discharged from the transit mixer directly to the form work or placed by wheelbarrow, proper sealed chutes must be constructed to avoid spillage. If the concrete is being placed with a concrete pump, all hose and pipe connections must be sealed and locked properly to ensure the lines will not leak or uncouple. Crews will ensure that concrete forms are not filled to overflowing.
- Sealing forms: All concrete forms will be constructed in a manner which will prevent fresh concrete or cement laden water from leaking into the surrounding water.

Curing concrete

- When fresh water is used to cure concrete, the run off must be monitored for acceptable pH levels. If the pH levels are outside the allowable limits then the run off water must be contained and neutralized.

Grinding concrete

- When grinding cured concrete the dust and fines entering the water must not exceed the allowable limits for suspended solids. When grinding green or not completely cured concrete and the dust or fines are entering the water, pH monitoring will be conducted to ensure allowable ranges are maintained. In the event that the levels are outside the acceptable ranges preventative measures will be introduced. This could include introducing silt curtains to contain the solids and prevent fish from entering a contaminated area or constructing a catch basins to recover the run off and neutralizing it prior to disposal.

Patching concrete

- Spills: When patching concrete all spills must be contained and prevented from falling into the water.

Washing down hand tools, pumps and transit mixer

- All tools, pumps, pipes, hoses and trucks used for finishing, placing or transporting fresh concrete must be washed off in such a way as to prevent the wash off water from entering the marine environment. The wash water will be contained and disposed of upland in an environmentally acceptable manner.

Whenever there is the possibility of contaminants entering habitat waters, the contractor will monitor pH levels to ensure acceptable levels.