

TENDER ADDENDUM

To Supply and Deliver Lighting Equipment
NCC tender file # LW027
April 8, 2016
ADDENDUM NO : 2

ADDENDA À LA SOUMISSION

Fournir et livrer équipement pour éclairage
Dossier de soumission de la CCN no. LW027
le 8 avril 2016
ADDENDA NO: 2

The following shall be read in conjunction with and shall form an integral part of the Tender / Proposal and Contract Documents :

Ce qui suit doit être interprété comme faisant partie intégrante de la proposition/appel d'offres et des documents relatifs au contrat:

1. CORRECTION:

Required Electrical Wire – Professional Grade : Please remove the cable requirement (last item) from Appendix 1.

1. CORRECTION :

Filage électrique nécessaire – Pour usage professionnel : Veuillez supprimer l'exigence de filage (dernier élément) sur Appendice 1.

2. QUESTION AND ANSWERS :

Q1. Is there a statement of work available for us to reference so that we can make sure the functionality and clients experience criteria is met?

A1. No

Q2. Is there a wiring diagram available to insure we include all the cabling and infrastructure necessary for the installation and functionality requirements?

A2. There is no wiring diagram.

Q3. Could you please provide clarification for the installation (if any) requirements beyond the “Wiring section”?

A3. All equipment must be delivered to the Capital Urbanism Lab, 2nd Floor. No installation is required.

Q4. Please advise if the attached are suitable alternatives to items 1, 3, and 6 on Appendix 1 of the tender document. (See attached 3 – “Question #2...” for alternatives)

A4. Yes, the products are suitable alternatives. Please ensure that the appropriate barndoors are provided.

Q5. Who is doing the installation of the equipment?

A5. Another tender will be held to retain a supplier for installation services.

2. QUESTIONS ET RÉPONSES :

Q1. Y-a-t-il un énoncé de besoins qui serait à notre disponibilité afin de s’assurer que la fonctionnalité et les critères d’expérience du client sont comblés?

R1. Non

Q2. Est-ce que le diagramme du câblage est disponible afin de s’assurer d’inclure tout le câblage et les infrastructures nécessaires à l’installation et les besoins de fonctionnalité?

R2. Il n’y a pas de diagramme pour le filage.

Q3. Pouvez-vous fournir une clarification concernant l’installation (s’il y a lieu) des exigences au-delà de la section sur le `câblage`?

R3. Tous les équipements doivent être livrés au laboratoire d’urbanisme de la capitale, 2ième étage.

Q4. Veuillez nous aviser si les items en pièce jointes sont des items équivalents aux items 1, 3, et 6 de l’annexe 1 sur document d’appel d’offres. (Voir pièce jointe 3 – « Question #2... » pour les possibilités)

R4. Oui, les équipements sont des équivalents que nous approuvons. Veuillez vous assurer que les portes de grange appropriées sont fournies.

Q5. Qui fera l’installation de l’équipement?

R5. Un autre appel d’offre aura lieu afin de retenir un fournisseur pour les services d’installation.

Q6. Do you have a floor plan?

A6. Yes, a copy is attached



Lana Wilson
Senior Contract Officer
Procurement Services

Q6. Avez-vous un plan de site ?

R6. Oui, une copie se trouve en pièce jointe.



Lana Wilson
Agent principal des contrats
Services d'approvisionnement

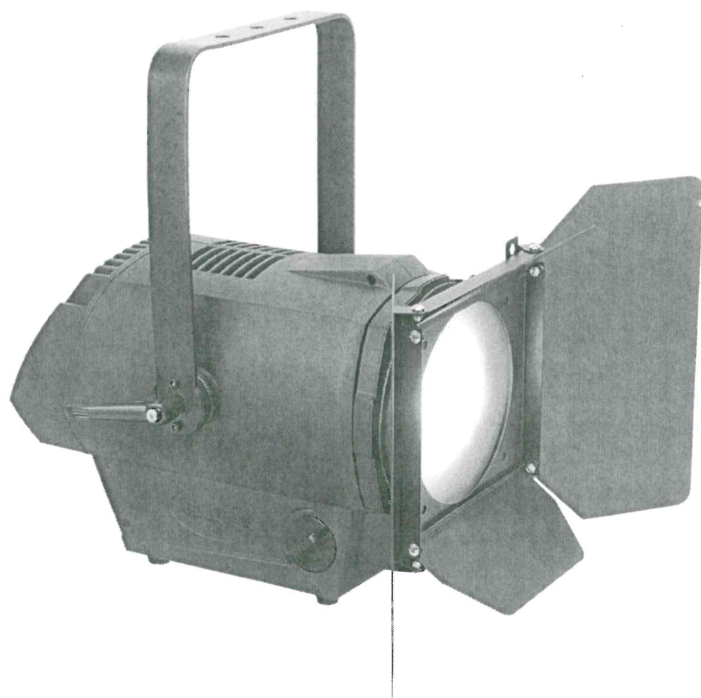

DW FRESNEL™

SKU # **DLE064**

The new DW Fresnel™ features a 250W 100,000 hour average life dynamic LED engine, 13° to 41° manual zoom, variable color temperature settings (3,200K - 6,000K), no noise thermo-optical cooling, manual and DMX controlled strobe and dimmer, variable dimming curves, flicker free operation for TV and FILM, rotating barn door and gel frame with frost filter, 3 and 5 pin in/out DMX and powerCON in connections, (4) button (3) dial control panel, 320W max power consumption, and a multi-voltage universal auto switching power supply (100-240v).

FEATURES

250W 100,000 Hour Average Life Dynamic LED Engine

Manual Zoom: 13° - 41°

Variable Color Temperature Settings (3,200K - 6,000K)

No Noise Thermo-Optical Cooling Technology

Manual or DMX Controlled Color Temp and Dimming

Variable Dimming Curves

Flicker Free Operation for TV and FILM

Rotating Barn Door, Gel Frame and Frost Filter

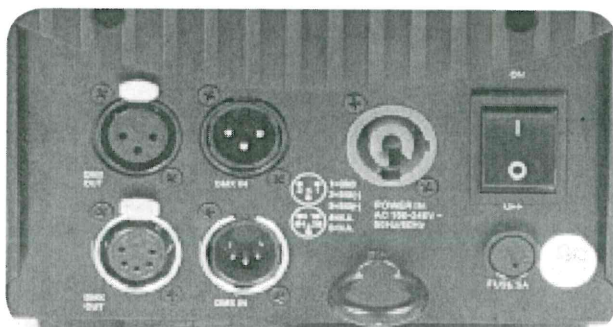

PRODUCT SPECIFICATIONS

FEATURES

- 13° - 41° Manual Zoom
- Variable Color Temperature (3,200 - 6,000K)
- No Noise Thermo-Optical Cooling Technology
- Manual and DMX Controlled Color Temp and Dimming
- Flicker FREE Operation for TV and FILM
- Rotating Barn Door, Gel Frame and Frost Filter

SOURCE

- 250W Dynamic White LED Engine
- 100,000 Hour Average Life

PHOTOMETRIC DATA

Lens Dia: 7" (175mm) HIGH CRI = >90 / up to 8,716 lm
 28,520 LUX 2650 FC @8.2' (2.5M) (13° Full On 4,800K)
 2,742 LUX 255 FC @8.2' (2.5M) (41° Full On 4,800K)

EFFECTS

- Variable Strobe Settings (1-18 fps)
- Electronic Dimming (0% - 100%)
- Variable Dimming Curves

CONTROL / CONNECTIONS

- (4) Button and (3) Dial Control Panel LCD Menu Display
- Manual or DMX Controlled Color Temp and Dimming
- 3 DMX Channels Modes (2 / 3 / 8)
- 3 and 5 pin DMX In/Out
- powerCON Power In

SIZE / WEIGHT

- Length: 23.4" (595 mm)
- Width: 10.4" (264 mm)
- Height: 17.8" (453 mm)
- Weight: 24.0 lbs. (10.9 kg)

ELECTRICAL / THERMAL

- AC 100-240V - 50/60Hz
- 320W Max Power Consumption
- 14° to 113°F (-10° to 45°C)

APPROVALS / RATINGS

CE | cETLus | IP20

INSTALLATION

- Rigging: Clamp or Stand (Not Included)
- Working Position: Any (360°)

INCLUDED ITEMS

- (1) Rotating Barn Door, Gel Frame and Frost Filter
- (1) powerCON Cable
- (1) 3pin XLR Cable
- (3) Safety Cables

PHOTOMETRIC DATA

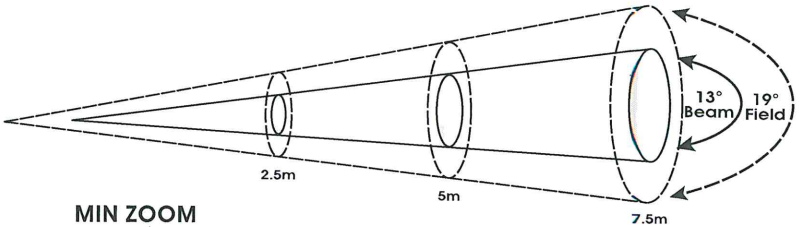

MIN ZOOM

	Distance	2.5 m	8.2 ft	5 m	16.4 ft	7.5 m	24.6 ft
13° Beam Diameter		0.55	1.8	1.1	3.6	1.65	5.4
19° Field Diameter		0.85	2.8	1.7	5.6	2.55	8.4
		lux	fc	lux	fc	lux	fc
FULL ON		28,520	2,650	7,410	688	3,519	327
COOL WHITE		15,960	1,483	4,315	401	2,029	188
WARM WHITE		12,730	1,183	3,441	320	1,594	148

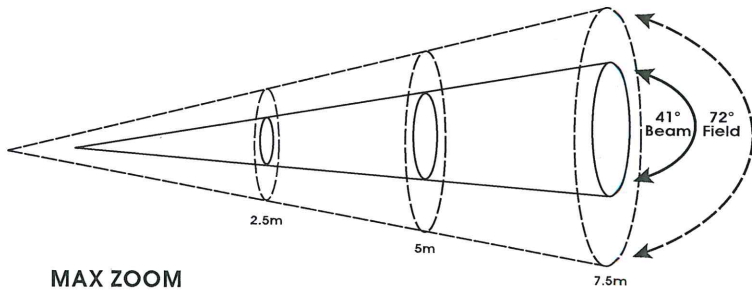

MAX ZOOM

	Distance	2.5 m	8.2 ft	5 m	16.4 ft	7.5 m	24.6 ft
41° Beam Diameter		1.86	6.1	3.72	12.2	5.58	18.3
72° Field Diameter		3.6	11.8	7.2	23.6	10.8	35.4
		lux	fc	lux	fc	lux	fc
FULL ON		2,742	255	791	73	395	37
COOL WHITE		1,550	144	447	42	219	20
WARM WHITE		1,232	114	359	33	174	16

DIMENSIONAL DIAGRAMS

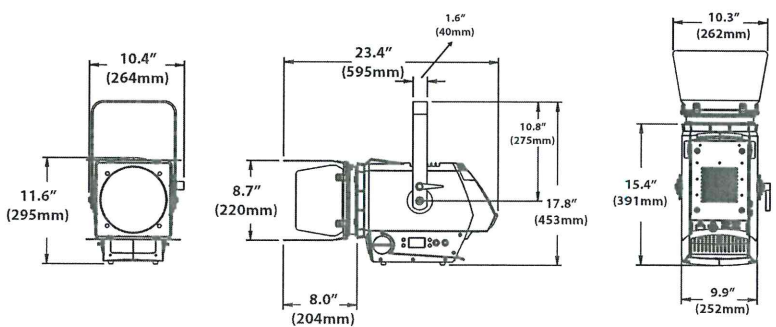

OPTIONAL ACCESSORIES

ORDER CODE	ITEM
TRIGGER CLAMP	Heavy Duty Wrap Around Hook Clamp
** pending **	Flight Case For DW Fresnel
AC3PDMX10PRO	10 ft. (3m) 3pin PRO DMX Cable
AC3PDMX25PRO	25 ft. (7.5m) 3pin PRO DMX Cable
AC3PDMX50PRO	50 ft. (15.2m) 3pin PRO DMX Cable
AC5PDMX10PRO	10 ft. (3m) 5pin PRO DMX Cable
AC5PDMX25PRO	25 ft. (7.5m) 5pin PRO DMX Cable
AC5PDMX50PRO	50 ft. (15.2m) 5pin PRO DMX Cable



Specifications are preliminary and subject to change without notice ©Elation Professional | 06.26.15

Elation Professional USA | 6122 S. Eastern Ave. | Los Angeles, CA. 90040
 323-582-3322 | 323-832-9142 fax | www.elationlighting.com | info@elationlighting.com

Elation Professional B.V. | Junostraat 2 | 6468 EW Kerkrade, Netherlands
 +31 45 546 85 66 | +31 45 546 85 96 fax | www.elationlighting.eu | info@elationlighting.eu

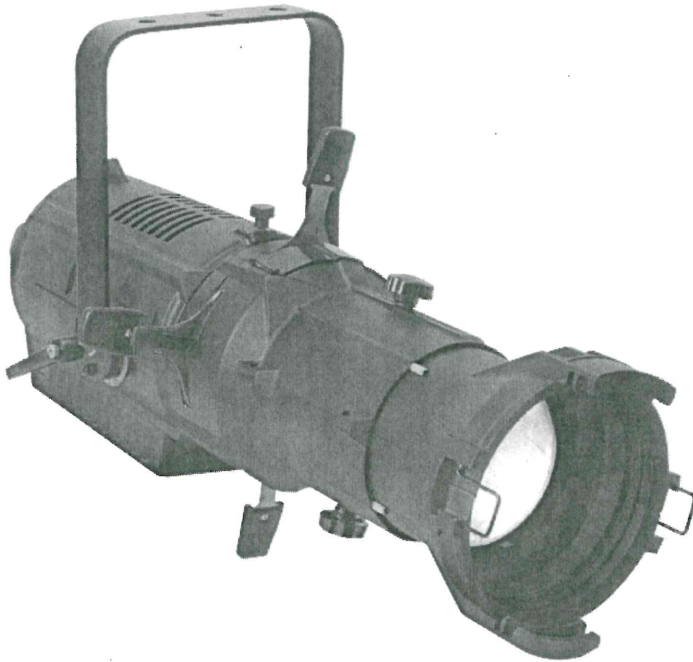

WW PROFILE™

SKU# **WWP001**

The new WW Profile™ Ellipsoidal features a 130W Warm White 3,000K LED engine, >94CRI, high efficiency offering 6,700 total lumens (with 26° lens) with only 160W max power consumption (42 lumens per watt), 19°, 26°, 36°, and 50° interchangeable lens options (sold separately), (4) blade manual framing shutters, supports B size metal or HT transparency gobos, manual focus, DMX controlled electronic strobe, dimming, and dimming curves, flicker free operation for TV and FILM, adjustable refresh frequency and gamma brightness, 3/5pin DMX and powerCON in/out connections, (4) button LCD control display panel, an integrated rigging yoke, quiet fan cooling, and a multi-voltage universal auto switching power supply (100-240v).

FEATURES

- 130W Warm White 3,000K LED Engine**
- >94CRI, 6,700 Total Lumens***
- 160W Max Power Consumption / 42 Lumens Per Watt**
- Interchangeable Lens Options** 19°, 26°, 36°, 50°**
- (4) Blade Manual Framing Shutters**
- Supports B Size Metal or HT Transparency Gobos*****
- Electronic Strobe and Variable Dimming Curves**
- Flicker Free Operation for TV and FILM**
- Adjustable Refresh Frequency and Gamma Brightness**
- Quiet Fan Cooling**
- (*with 26° lens) (**sold separately)(***gobos and holder not included)**



ELATION | WW PROFILE™ | Product Specification Sheet

PRODUCT SPECIFICATIONS

SOURCE

1 30W Warm White 3,000K LED Engine
50,000 Hour Average LED Life*

*LED Life may vary depending on several factors including but not limited to: Environmental Conditions, Power/Voltage, Usage Patterns (On-Off Cycling), Control and Dimming.

PHOTOMETRIC DATA

>94CRI, 6,700 Total Lumens*
(*with 26° lens)

EFFECTS

Electronic Strobe and Dimming
Variable Dimming Curve Modes

GOBOS

Supports "B" Size Metal, HT Transparency Gobos*
*Gobos and Holder not included.

CONTROL / CONNECTIONS

2 DMX Channel Modes (1 / 4)
Adjustable Refresh Rate (900-1500, 25,000 Hz)
Adjustable Gamma Brightness (2.0, 2.2, 2.4, 2.8)
4 Button Control Panel / LED Menu Display
3/5pin DMX In/Out / powerCON In/Out

SIZE / WEIGHT

Length: 24.3" (618mm) / 26.5" (674mm) Fully Extended
Width: 12.2" (310mm)
Vertical Height: 15.7" (398mm)
Weight: 21.0 lbs. (9.5 kg)

ELECTRICAL / THERMAL

Quiet Fan Cooling
AC 100-240V - 50/60Hz
160W Max Power Consumption
14° to 113°F (-10° to 45°C)

APPROVALS / RATINGS

CE | cETLus | IP20



INSTALLATION

Rigging: Integrated Yoke
Working Position: Any (360°)

INCLUDED ITEMS

- (1) powerCON Cable
- (1) 3pin DMX Cable
- (1) Safety Cable

LENS Options (sold separately)

19°, 26°, 36°, 50°

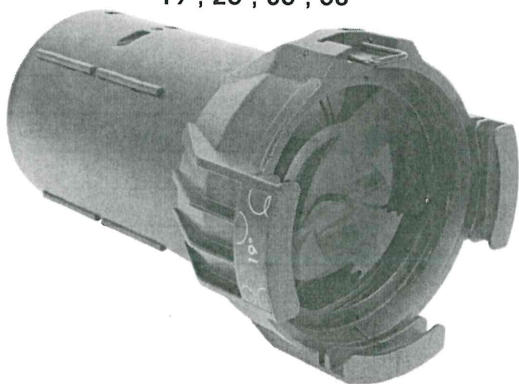

PHOTOMETRIC DATA

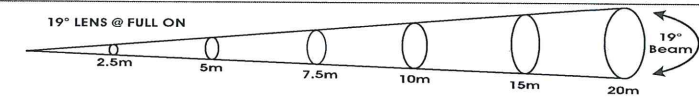

2.5m		5m		7.5m		10m		15m		20m		
m	ft	m	ft	m	ft	m	ft	m	ft	m	ft	
Diameter	0.79	2.6	1.61	5.3	2.43	8.0	3.21	10.5	4.8	15.7	6.4	21.0
Photometrics	17,450	1,621	4,077	379	1,797	167	1,047	97	499	46	312	29

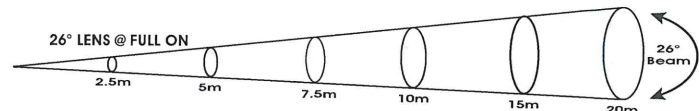

2.5m		5m		7.5m		10m		15m		20m		
m	ft	m	ft	m	ft	m	ft	m	ft	m	ft	
Diameter	1.14	3.7	2.25	7.4	3.45	11.3	4.6	15.1	6.9	22.6	9.2	30.2
Photometrics	7,818	726	2,000	186	961	89	597	55	294	27	160	15

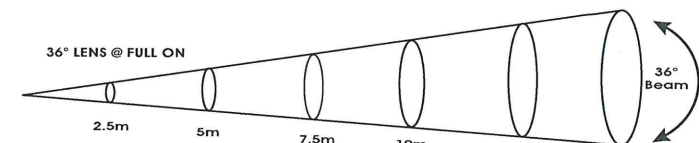

2.5m		5m		7.5m		10m		15m		20m		
m	ft	m	ft	m	ft	m	ft	m	ft	m	ft	
Diameter	1.5	4.9	3	9.8	4.51	14.8	6.01	19.7	9	29.5	11.9	39.0
Photometrics	5,319	494	1,395	130	634	59	389	36	195	18	120	11

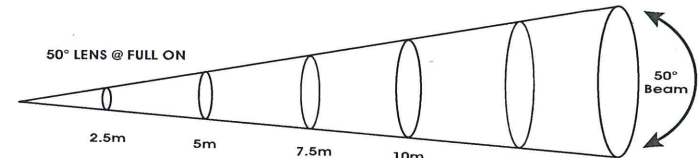

2.5m		5m		7.5m		10m		15m		20m		
m	ft	m	ft	m	ft	m	ft	m	ft	m	ft	
Diameter	2.13	7.0	4.24	13.9	6.37	20.9	8.49	27.9	12.7	41.7	16.98	55.7
Photometrics	1,982	184	563	52	268	25	152	14	74	7	45	4

DIMENSIONAL DIAGRAM

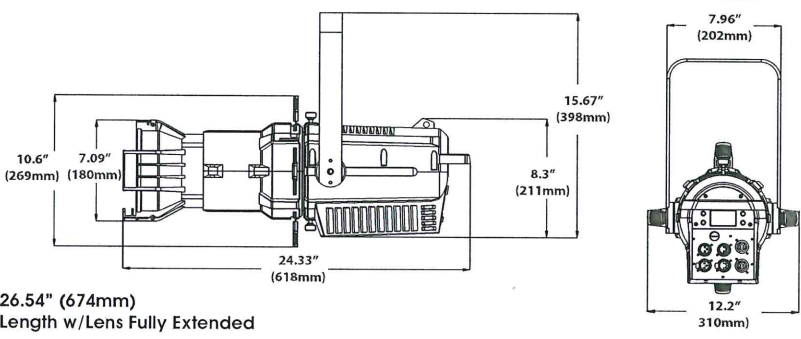

26.54" (674mm)
Length w/Lens Fully Extended

OPTIONAL ACCESSORIES

ORDER CODE	ITEM
TRIGGER CLAMP	Heavy Duty Wrap Around Hook Style Clamp
PHD019	Profile High Definition Lens 19°
PHD126	Profile High Definition Lens 26°
PHD236	Profile High Definition Lens 36°
PHD350	Profile High Definition Lens 50°
AC3PDMX5PRO	3 ft. (1m) powerCON PRO Link Cable
AC3PDMX5PRO	5 ft. (1.5m) 3pin PRO DMX Cable
AC5PDMX5PRO	5 ft. (1.5m) 5pin PRO DMX Cable



Specifications are subject to change without notice ©Elation Professional 2/19/16

Elation Professional USA | 6122 S. Eastern Ave. | Los Angeles, CA, 90040
323-582-3322 | 323-832-9142 fax | www.elationlighting.com | info@elationlighting.com

Elation Professional B.V. | Junostraat 2 | 6468 EW Kerkrade, The Netherlands
+31 45 546 85 66 | +31 45 546 85 96 fax | www.elationlighting.eu | info@elationlighting.eu

5

Jump to Product:

[Parts \(http://parts.adj.com/\)](http://parts.adj.com/) [Forums \(http://forums.americandj.com\)](http://forums.americandj.com)

[Visit Showroom \(http://apptcal.americandj.com/Calendar.aspx\)](http://apptcal.americandj.com/Calendar.aspx) [Support \(http://www.adj.com/support/\)](http://www.adj.com/support/)

[ADI Rewards Program \(http://www.adj.com/portal/\)](http://www.adj.com/portal/) [My Account \(http://www.adj.com/portal/\)](http://www.adj.com/portal/)



[\(http://www.adj.com/\)](http://www.adj.com/)

MENU

[HOME \(HTTP://WWW.ADJ.COM/\)](http://www.adj.com/) > [SCENE SETTER \(\)](#)

Search

[DJ & Mobile \(http://www.adj.com/industries/dj/\)](http://www.adj.com/industries/dj/)

[Club Install \(http://www.adj.com/industries/club-install/\)](http://www.adj.com/industries/club-install/)

[Production Events \(http://www.adj.com/industries/production-events/\)](http://www.adj.com/industries/production-events/)

[Worship \(http://www.adj.com/industries/worship/\)](http://www.adj.com/industries/worship/)

[Band & Stage \(http://www.adj.com/industries/band-stage/\)](http://www.adj.com/industries/band-stage/)

[Party \(http://www.adj.com/industries/party/\)](http://www.adj.com/industries/party/)

Scene Setter

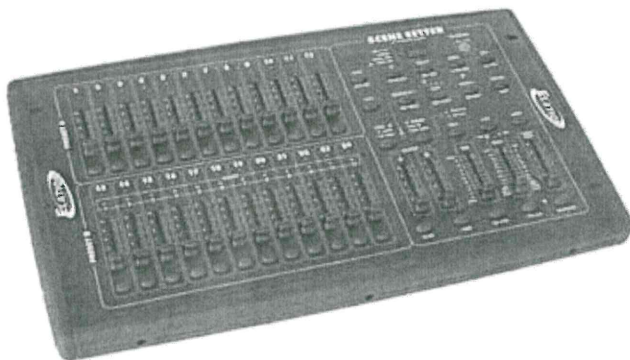

6

**SKU: SCENE SETTER**

Like 0

Tweet

G+ 0

ADJ's Scene Setter is a 24 Channel Dimming Console for the purpose of managing the levels on your conventional light entertainment system. With lots of built-in reprogrammable scenes and chases you can easily create and manage your light show. This portable control system is perfect for the DJ at home, club, bar, on the road, or for any professional stage production.

Advantage Points: 250

Where to Buy

Enter your zip code below to find this product at a retailer near you!

Zip Code

Go

Product DescriptionSpecifications

Specifications

- 24 channel conventional dimming console
- Two scene operation (A/B faders)
- 4200 programmable scenes- password protected
- 48 programmable chases (stacks)- password protected
- Solo & Pile On chase operation
- Blind & Dark functions
- 24 individual channel faders
- 24 bump buttons
- Tap Sync button for chase speed / fade override
- Independent speed & fade control

Floor Plan - Urbanism LAB - 2nd Floor
Plan de Site - Laboratoire d'urbanisme - 2^{ème} étage

