



Fisheries and Oceans
Canada

Pêches et Océans
Canada

Canadian
Coast Guard

Garde côtière
canadienne



SOW – PIER AND TOWER REPLACEMENT

LL 1471 SAFETY BAY

KENORA, ON

MARITIME AND CIVIL INFRASTRUCTURE

Prepared by: DJ

Approved by: BY

Revision: 1

File: EWTM 8010-1471000

Rev Date: 19 APR 16



Fisheries and Oceans
Canada

Pêches et Océans
Canada

Canadian
Coast Guard

Garde côtière
canadienne



TABLE OF CONTENTS

SECTION:	011100 GENERAL INSTRUCTIONS	1
SECTION:	013300 SUBMITTAL PROCEDURES	6
SECTION:	013530 HEALTH AND SAFETY REQUIREMENTS	7
SECTION:	013543 ENVIRONMENTAL PROCEDURES	8
SECTION:	014500 QUALITY CONTROL.....	11
SECTION:	016100 COMMON PRODUCT REQUIREMENTS	13
SECTION:	024116 DEMOLITION OF STRUCTURES.....	15
SECTION:	055000 METAL FABRICATIONS	18
SECTION:	133613 METAL TOWERS.....	21



SECTION: 011100 GENERAL INSTRUCTIONS

PART 1 - GENERAL

1.1 Minimum Standards

- .1 Perform work in accordance with National Building Code of Canada (NBC) and any other code of provincial or local application. In the case of any conflict or discrepancy, the more stringent requirements shall apply.
 - .1 Meet or exceed requirements of:
 - .1 Contract documents;
 - .2 Specified standards, codes and referenced documents.

1.2 Description of Work

- .1 Work under this Contract includes but is not limited to the provision of all labour, materials, and equipment required to:
 - .1 Mobilize to site with a work barge of appropriate size and certification;
 - .2 Salvage existing aid to navigation (ATON) complete with all appurtenances
 - .3 Demolish and dispose of existing concrete foundation
 - .4 Install one [1] new drilled steel pier;
 - .5 Install one [1] new ATON on this pier (ATON supplied by CCG);
 - .6 Install salvaged ATON appurtenances as instructed
 - .7 Demobilize.
- .2 The following work will be undertaken by others and is hereby excluded:
 - .1 Supply of jig and tower base plate as shown in appended drawings
 - .2 Supply one [1] aid to navigation tower.

1.3 Submittals

- .1 Mandatory submittals and schedule for submission are detailed below and in Appendix B2. The following identifies general requirements only. The relevant sections must be consulted for a complete listing of mandatory content.



Fisheries and Oceans
Canada

Pêches et Océans
Canada

Canadian
Coast Guard

Garde côtière
canadienne



.2 Detailed Schedule:

.1 Deadline:

.1 No later than ten (10) working days following award.

.2 Deliverables:

.1 The contractor shall furnish a high level schedule outlining the major construction milestones. Schedule shall clearly define the anticipated start and finish of the project.

.3 Proof of Qualifications:

.1 Deadline:

.1 No later than ten [10] working days following award.

.2 Deliverables:

.1 Contractor shall furnish proof of vessel registration.

.2 Contractor shall furnish listing of all subcontractors.

.4 Construction Plan:

.1 Deadline:

.1 No less than ten [10] working days prior to mobilization.

.2 Deliverables:

.1 A Construction Plan of sufficient detail to demonstrate that the Contractor has considered all the challenges of the project and is prepared to undertake the works in a competent and professional manner in accordance with all legislation, including:

.1 Project specific safety program (Section 013530);

.2 Project environmental protection plan (Section 013543);

.3 Detailed demolition plan (Section 024116);

.4 Detailed construction plan (Section 055000);

1.4 Bidder Qualifications

.1 The work shall be carried out under the supervision and responsibility of a sole specialized Contractor, capable of performing installations of offshore drilled foundations.

.2 The Contractor shall designate a project manager or main point of contact for the contract.



- .3 The Contractor shall provide a detailed list of all subcontractors being used to complete the work described herein.

1.5 Site Location

- .1 The location of the site is as follows:
 - .1 Lat./Long.: 49°45'34.73"N, 94°31'24.19"W
 - .2 The closest settlement is Kenora, Ontario.
 - .3 The site is located on a shallow shoal, offshore in Lake of the Woods.

1.6 Existing Conditions

- .1 Bidders must make their own estimate of the difficulties associated with all phases of the works.
- .2 The contractor must include in their costs all expenses related to the difficulties of working at the sites.
- .3 Photographs of the existing site are included in Appendix B1.
- .4 A geotechnical investigation has not been completed for this location.

1.7 Contractor's Access to Site

- .1 Contractor is responsible for transportation of all labour, materials, and equipment to and from the sites, including any and all material furnished or itemized for salvage by Coast Guard.
- .2 The Site is accessible by water only. The site is located on a shoal in Lake of the Woods, approximately 5 km northwest of the staging location in Kenora, ON.
- .3 The Contractor is responsible for sourcing appropriate marine access to support all construction work. Contractors are also responsible for ensuring that all the requirements of Appendix B4 – Marine Access Requirements are met.
 - .1 Contractor shall provide proof of vessel registration in the 'proof of qualifications' submittal.

1.8 Completion, Scheduling and Planning of the Works

- .1 Work may commence as early as practical following coast guards acceptance and approval of mandatory submissions.
- .2 Site work shall not commence without written authorization of Coast Guard Project Authority.
 - .1 Advise Project Authority at least two (2) weeks in advance of proposed installation date
- .3 Work shall be completed no later than November 30th, 2016 unless otherwise negotiated and approved in writing.



1.9 Coast Guard Staging Location

- .1 Items itemized as supplied by, or salvaged to Coast Guard shall be collected or delivered by the Contractor to the following staging location. The Contractor shall be responsible for all transportation costs between the project site and the identified staging location. Material drop off or access to stored goods outside of regular operating hours shall be at the discretion of Coast Guard and may be subject to cost recovery:

- .1 Staging location: CCG Base – Kenora, 1100 Third Ave. South, Kenora, Ontario P9N 4H4.

- .2 Advise Coast Guard at least three (3) working days prior to pick-up/delivery

- .1 For Delivery or Pickup, contact Earl Henley, 807-468-6441 Ex 21 (Cell 807-323-0482), earl.henley@dfo-mpo.gc.ca .

- .2 Shipping/Receiving hours: Monday through Friday, 9:00AM to 3:00PM.

1.10 Temporary Facilities

- .1 Provide sanitary facilities for work force in accordance with governing regulations and ordinances.
- .2 Arrange, pay for, and maintain temporary electrical power supply as required for construction, and water supply as required, in accordance with governing regulations and ordinances.
- .3 Maintain emergency spills kit on-site at all times.

1.11 Fees, Permits, Certificates and Information

- .1 Contractor shall provide authorities having jurisdiction with all information requested.
- .1 Contractor shall provide copies to Coast Guard of any documentation submitted to other authorities related to the work described in this document.
- .2 Contractor shall pay fees and obtain certificates and permits required.
- .3 Contractor shall furnish certificates and permits when requested.

1.12 Reference Documents

- .1 The most recent publication or edition of any document referenced in this specification should be used unless the referencing clause states that this clause does not apply.

1.13 Required Submissions

- .1 A summary of the minimum mandatory submissions required can be found in Appendix B2. This summary is not an exhaustive list of all submissions required for the duration of the project. Additional submissions may be required after award.



Fisheries and Oceans
Canada

Pêches et Océans
Canada

Canadian
Coast Guard

Garde côtière
canadienne



PART 2 - PRODUCTS

2.1 Not Used

PART 3 - EXECUTION

3.1 Not Used



SECTION: 013300 SUBMITTAL PROCEDURES

PART 1 - GENERAL

1.1 General

- .1 This section specifies general requirements and procedures for the Contractor's submissions of documents to Coast Guard for review.
- .2 Do not proceed with the work until submitted documents or samples have been reviewed by Coast Guard.
- .3 Where items or information is not produced in SI Metric units, converted values are acceptable.
- .4 Contractor's responsibility for errors and omissions in submission is not relieved by Coast Guard's review of the submitted documents.
- .5 Notify Coast Guard, in writing at time of submission, identifying deviations from requirements of Contract Documents stating reasons for deviations.
- .6 Contractor's responsibility for deviations in submission from requirements of Contract Documents is not relieved by Coast Guard's review of submission, unless Coast Guard gives written acceptance of specific deviations.
- .7 Make any changes to submissions that Coast Guard may require consistent with Contract Documents and resubmit as directed by Coast Guard.
- .8 Provide Coast Guard with a written notice, when resubmitting, of any revisions other than those requested Coast Guard.

1.2 Submission Requirements

- .1 Coordinate each submission with requirements of work and Contract Documents. Individual submissions will not be reviewed until all related information is available.
- .2 Allow three (3) working days, or as stipulated in the specifications, for Coast Guard to review the submission.
- .3 The Contractor's Engineer shall stamp and sign any submissions requiring a Professional Engineer's seal certifying his approval of samples, verification of field measurements, and compliance with Contract Documents.



SECTION: 013530 HEALTH AND SAFETY REQUIREMENTS

PART 1 - GENERAL

1.1 Scope

- .1 The Contractor shall be responsible to develop, implement and enforce a safety program which addresses all elements of the work.
- .1 Due to the specific requirements of the project the Contractor is required to include the following as minimum mandatory requirements of their submitted safety program.

1.2 References

- .1 Work under this section shall be undertaken in strict conformance with all listed references, In the case of any conflict or discrepancy the more stringent requirements shall apply.
 - .1 Canada Labour Code Part II - January 2008
 - .2 NRC-CNRC National Building Code of Canada
 - .3 Ontario Occupational Health and Safety Act and Regulations, 2009.
 - .4 Any and all other Provincial/Territorial Regulations and Policies; Worker's Compensation Board Policies; Local municipal regulations; pertaining to safety of the contractors workers

1.3 Submittals

- .1 Project Specific Safety Program
 - .1 Deadline:
 - .1 With Construction Plan
 - .2 Deliverables:
 - .1 Safety Program Document, include:
 - .1 A listing of all activities specific to this phase of the project and their Health & Safety risks or hazards.
 - .2 Detailed descriptions of how the activities are to be carried out as well as methods for mitigating hazards and risks.
 - .3 A listing of personnel responsible for health and safety measures, and Emergency procedures.
 - .4 Material Safety Data Sheets for hazardous products to be utilized in the execution of the works.



SECTION: 013543 ENVIRONMENTAL PROCEDURES

PART 1 - GENERAL

1.1 Scope of Work

- .1 The Contractor must implement and enforce the following procedures throughout the duration of the work to mitigate potential negative impacts on the surrounding environment.

1.2 References

- .1 Work under this section shall be undertaken in strict conformance with all listed references, In the case of any conflict or discrepancy the more stringent requirements shall apply.

- .1 Canadian Environmental Protection Act

1.3 Related Sections

- .1 Not used.

1.4 Submittals

- .1 Contractor shall submit and environmental protection plan

- .1 Deadline:

- .1 With Construction Plan

- .2 Deliverables:

- .1 Submit a plan addressing procedures to be implemented to mitigate any negative impact on the environment. Detail:

- .1 Equipment features (age, spill containment);
- .2 Staging, refueling, and cleaning areas;
- .3 Clean-up and/or containment procedures (including concrete/grout);
- .4 Waste disposal methods and sites;
- .5 De-watering plan.

PART 2 - PRODUCTS

2.1 General

- .1 Avoid use of hazardous products. Use environmentally friendly products where practical.



PART 3 - EXECUTION

3.1 Construction Area

- .1 Confine construction activities to as small an area as practical.
- .2 Establish material storage, cleaning, and refueling areas where impacts to the surrounding environment will be negligible or readily mitigated.

3.2 Stockpiling of materials

- .1 Materials must be stockpiled as far from the shoreline as practical. Tarps must be used to control dust and run-off.
- .2 Stockpiled excavated materials shall be skirted using filter fabric to control run-off of fines during rain.

3.3 Disposal of Wastes

- .1 Clean-up the site at the end of each working day.
- .2 All waste material to be disposed of in a legal manner at a site approved by local authorities. Transporter/hauler must be appropriately licensed.
 - .1 Recycle or reuse materials where possible.
- .3 Fires and burning of rubbish on site not permitted.
- .4 Do not bury rubbish and waste materials on site.

3.4 Clearing and Grubbing

- .1 Only clear vegetation that interferes with construction.

3.5 Drainage

- .1 Provide temporary drainage and pumping as necessary to keep excavations and site free from water.
 - .1 Suspend works during periods of heavy rainfall and add temporary covers to discourage run-off.
 - .2 Water pumped from excavation shall be adequately treated to ensure that water returning to the watercourse contains minimal fines. Procedures anticipated for preventing the pumping of fines shall be identified in the environmental protection plan, and may include the following:
 - .1 The use of filter bags;
 - .2 Straw bale check dams or silt fence;
 - .3 Discharge through naturally occurring vegetation.



- .3 The means for controlling silt run-off shall be dependent on the site and the quantity of water pumped, and shall be to the discretion of the CCG site staff.
- .4 Sediment control measures shall be inspected and improved/cleaned/replaced as necessary.

3.6 Pollution Control

- .1 Provide methods, means, and facilities to prevent the contamination of soil, water, and atmosphere from the discharge of pollutants produced by construction operations.
- .2 Vehicles, machinery, and equipment shall be in good repair, equipped with emission controls as applicable and operated within regulatory requirements.
- .3 Abide by local noise by-laws.
- .4 Avoid unnecessary idling of vehicles or heavy machinery.
- .5 Limit use of equipment around the shoreline where possible.
- .6 Implement and maintain dust and particulate control measures in accordance with provincial requirements:
 - .1 All bulk material haul equipment shall be appropriately tarped. Watertight vehicles shall be used to haul wet materials
 - .7 Designate a cleaning area for tools to limit water use and runoff. Do not allow deleterious materials to enter waterways. Ensure emptied containers are sealed and stored safely for disposal.
 - .8 The contractor shall take all necessary precautions to guard against the release of any noxious substance or pollutant to the environment. In the event of any spill the Contractor shall take immediate action to contain the release and mitigate any impact.
 - .1 Materials and equipment to intercept, contain, and clean-up any spill or other release shall be maintained on site throughout the construction period and must be readily accessible at all times.
 - .2 Any uncontrolled release of a known contaminant (spills, fire/smoke) shall be reported to appropriate Provincial Authority and Coast Guard. Spills of deleterious substances to be immediately contained and cleaned up in accordance with provincial regulatory requirements.
 - .3 Provincial Authority: Ontario Spills Action Centre 1-800-268-6060

3.7 Traffic

- .1 Minimize soil compaction by driving, parking vehicles, and walking, etc. on existing paved roadways/laneways. If soil is impacted by compaction, compensate by restoring areas with new soil, as required.



SECTION: 014500 QUALITY CONTROL

PART 1 - GENERAL

1.1 Inspection

- .1 Canadian Coast Guard or its representative shall have access to the work at all times. If parts of the work are prepared off-site or in a shop, access shall be given to such work throughout the duration of the project.
- .2 In the event the work must be submitted to special testing, inspection or approvals prescribed by Canadian Coast Guard in these specifications or provided for in work-site regulations, the request for inspection must be made without unreasonable delay.
- .3 The below list identifies key milestones where the Canadian Coast Guard will require an opportunity to take samples/inspect:
 - .1 Location verification: The Coast Guard will confirm correct location for installation upon arrival of the barge at site. The contractor shall be required to provide access to the site at all times to CCG site staff.
 - .2 Pre-tensioning: The Coast Guard shall witness the pre-tensioning of the all-thread rods to the prescribed torque values.
 - .3 Installation of tower: The Coast Guard shall witness the erection of the new nav-aid tower and witness correct operation of the new light.

1.2 Procedures

- .1 Provide Canadian Coast Guard with advance notice whenever testing is required in accordance with these specifications, so that all parties involved can be present.
- .2 Provide necessary manpower and installations for obtaining and handling samples and material on site.
- .3 Provide access to site if the site is of remote nature whereby the contractor is responsible for providing access to the site

1.3 Rejected Work

- .1 Remove defective work, whether incorporated into the work or not, which has been rejected by Canadian Coast Guard as failing to comply with the contract documents. Replace or re-execute in accordance with the Contract Documents.

1.4 Tests and Mixture Formulas

- .1 Supply test reports and required mixture formulas.

1.5 Factory Tests

- .1 Submit test certificates as prescribed in the relevant section of the specifications.



Fisheries and Oceans
Canada

Pêches et Océans
Canada

Canadian
Coast Guard

Garde côtière
canadienne



1.6 Acceptance of Work

- .1 Canadian Coast Guard will make acceptance visits of work executed by the Contractor at critical milestones identified in the following sections.
- .2 The Contractor shall inform Canadian Coast Guard at least three (3) working days before these inspection visits.
- .3 All work shall be completed in compliance with the specifications before requesting the visit for inspection. If the work is not completed or deemed non-compliant, the Contractor shall be responsible for all costs incurred for subsequent inspections.



SECTION: 016100 COMMON PRODUCT REQUIREMENTS

PART 1 - GENERAL

1.1 General

- .1 Secure Coast Guard approval of all products to be incorporated into the works. Work shall not commence until product data and/or samples have received Coast Guard approval.
- .2 Supply and/or fabricate material and equipment of prescribed quality, with performance conforming to established standards.
- .3 Use new material and equipment unless otherwise specified.
- .4 Ensure replacements parts may be readily procured.
- .5 Use products from one manufacturer for material and equipment of same type or classification, unless otherwise specified.

1.2 Manufacturer's Instructions

- .1 Unless otherwise specified, comply with manufacturer's latest printed instructions for materials and installation methods.
- .2 Notify Canadian Coast Guard in writing of any conflict between these specifications and manufacturer's instructions; Canadian Coast Guard will designate which document is to be followed.

1.3 Compliance

- .1 When material or equipment is specified by standard or performance specifications, upon request of Canadian Coast Guard, obtain an independent testing laboratory report from the manufacturer, stating that material or equipment meets or exceeds specified requirements.

1.4 Substitution

- .1 Where specific products have been specified, proposals for substitution may only be submitted after award of contract. Such requests must include statements of respective costs of items originally specified and the proposed substitution.
- .2 No substitutions will be permitted without prior written approval of Canadian Coast Guard. Substitutions will be considered by Canadian Coast Guard only when:
 - .1 Materials specified in Contract Documents, are not available; or,
 - .2 Delivery date of materials selected from those materials specified would unduly delay completion of contract; or,
 - .3 Alternative materials to those specified which are brought to the attention of and considered by Canadian Coast Guard as equivalent to the material specified will result in a credit to the Contract amount.



Fisheries and Oceans Canada / Pêches et Océans Canada

Canadian Coast Guard

Garde côtière canadienne



- .3 Should the proposed substitution be accepted either in whole or in part, the Contractor must assume full responsibility and costs when such substitution affects other work on the project including any and all design or drawing changes required as a result of substitution.

1.5 Submittals

- .1 Provide product specifications and/or samples upon request from Coast Guard.



SECTION: 024116 DEMOLITION OF STRUCTURES

PART 1 - PART 1 - GENERAL

1.1 Scope of Work

- .1 Work under this section consists of the provision of all labour, materials, and equipment necessary to complete the following activities:
 - .1 Salvage and transport the existing tower, c/w all lighting equipment to the designated salvage location (Section 011000);
 - .2 Demolish the existing concrete pier to the bedrock elevation; and,
 - .3 Disposal of all waste at a licensed waste disposal facility.

1.2 References

- .1 Work under this section shall be undertaken in strict conformance with all listed references, In the case of any conflict or discrepancy the more stringent requirements shall apply.
 - .1 Canada Labour Code Part II - January 2008.
 - .2 NRC-CNRC National Building Code of Canada 2005.
 - .3 Ontario Occupational Health and Safety Act and Regulations, 2009.
 - .4 CSA S350-[M1980(R1998)], Code of Practice for Safety in Demolition of Structures.

1.3 Submittals

- .1 Contractor to provide demolition plan.
 - .1 Deadline:
 - .1 With Construction Plan.
 - .2 Deliverables:
 - .1 Method of demolition including all associated tasks and schedule;
 - .2 Methods for protecting the site from demolition debris.
 - .3 The ultimate disposal location of all waste materials and debris.
 - .1 Include documentation detailing regulatory approval for waste disposal facility and transporter.
- .2 Work under this section shall not proceed until written approval of the demolition plan has been received from the Coast Guard.



- .3 Submit copies of certified receipts from the disposal sites for all material removed from the work site upon request.

1.4 Existing Conditions

- .1 Existing pier is beyond its life expectancy, and multiple pieces of the steel structure have failed. Contractor must insure the tower is dismantled and demolished in a safe manner.
- .1 Photos of the existing pier and tower are included in Appendix B1.

PART 2 - PART 2 - PRODUCTS

- 2.1 Not used.

PART 3 - PART 3 - EXECUTION

3.1 General

- .1 Work under this section shall be continuous and proceed without interruption unless otherwise approved by Coast Guard.
- .2 It is preferred that pieces are lifted onto the barge in one piece to avoid environmental issues.
- .3 Demolition work shall not commence until the new pier and aid to navigation are complete and operational.

3.2 Protection

- .1 Implement effective controls to catch/collect all tower debris during demolition, specifically paint.
- .2 Implement effective controls to prevent injury to workers, and mariners.

3.3 Preparation

- .1 Erect warning signs and barricades.
- .2 Ensure all environmental protection/mitigation measures are in place.
- .3 Ensure all items identified for salvage have been removed and stored.

3.4 Demolition

- .1 Salvage the existing tower complete with all lighting equipment and related appurtenances,
- .2 Demolish existing concrete foundation in its entirety.
 - .1 All existing exposed rebar shall be cut flush to grade.
- .3 Ensure that demolition does not adversely affect adjacent watercourses, groundwater and wildlife, or contribute to excess air and noise pollution.



Fisheries and Oceans
Canada

Pêches et Océans
Canada

Canadian
Coast Guard

Garde côtière
canadienne



- .4 Ensure demolition is undertaken safely. If at any period during demolition the safety of the Contractor's staff cannot be maintained take preventative measures, stop work and immediately notify Coast Guard.

3.5 Disposal

- .1 All material is to be disposed of off-site and a licensed disposal/recycling facility.



SECTION: 055000 METAL FABRICATIONS

PART 1 - GENERAL

1.1 Scope of Work

- .1 Work of this section includes the supply of all labour, material, and equipment, necessary to complete the following activities:
 - .1 Installation of a pre-fabricated metal jig and a drilled pier foundation
- .2 The following work will be undertaken by others and is hereby excluded:
 - .1 The supply of the jig and tower base plate.
 - .1 Estimated weight is 375 kg (+/- 825 lbs)

1.2 References

- .1 Work under this section shall be undertaken in strict conformance with all listed references, In the case of any conflict or discrepancy the more stringent requirements shall apply.
 - .1 Canada Labour Code Part II - January 2008
 - .2 NRC-CNRC National Building Code of Canada 2010
 - .3 Ontario Occupational Health and Safety Act and Regulations
 - .4 CAN/CSA G40.20-13 – General Requirements for Rolled or Welded Structural Quality Steel
 - .5 CAN/CSA G164 - Hot Dip Galvanizing of Irregularly Shaped Articles.
 - .6 ASTM A36-14 - Standard Specification for Carbon Structural Steel
 - .7 ASTM A615-15 – Standard Specification for Deformed and Plain Carbon-Steel Bars for Concrete reinforcement
 - .8 ASTM A513-15 – Standard Specification for Electric-Resistance-Welded Carbon and Alloy Steel Mechanical Tubing

1.3 Submittals

- .1 Submittals shall be forwarded to Coast Guard in accordance with the provisions of section 013530.
- .2 Drilling Plan:
 - .1 Deadline:
 - .1 Furnish with Construction Plan (Section 011100)



.2 Deliverables:

- .1 Description of the equipment that will be utilized to install the drilled posts;
- .2 Description of the methods that will be implemented to stabilize the drilling equipment, and to ensure verticality of piles;
- .3 Description of how grouting and pre-tensioning activities will occur;
- .4 Provide cut-sheets for the grout to be used;
- .5 Provide cut-sheets for the Williams form products to be used;
- .6 Describe how works will be undertaken to mitigate impacts on the surrounding watercourse.

.3 As Built Drawings:

.1 Deadline:

- .1 21 Calendar days following the acceptance of the works

.2 Deliverables:

- .1 Drawing or sketch indicating the position of the constructed metal fabrication relative to the former installation, detail:
 - .1 Height of former pier, bedrock to top of foundation
 - .2 Highest high water mark of indicated on the former pier, relative to bedrock grade
 - .3 Height of new pier, bedrock to top of foundation
 - .4 Water level above bedrock
 - .5 Horizontal offsets to the centre of the new pier (north/south & east and west), relative to the former installation.

1.4 Quality Assurance

- .1 Coast Guards minimum inspection requirements are detailed below. The Contractor shall be responsible to notify Coast Guard of the date and time that the works may be inspected. Notice must be provided no less than three (3) working days in advance to permit scheduling of quality assurance testing. All deficiencies in the works identified at the time of inspection shall be remedied to the satisfaction of Coast Guard, by the Contractor at their expense. Work shall not progress until inspections have been completed and the Contractor has been provided with written notice to proceed with the works.
 - .1 Coast Guard is to confirm the correct jig location.
 - .2 Coast Guard is to witness tensioning of the all-thread rods.



Fisheries and Oceans
Canada

Pêches et Océans
Canada

Canadian
Coast Guard

Garde côtière
canadienne



PART 2 - PRODUCTS

2.1 All-thread rod, accompanying washers & nuts

- .1 All-thread rods shall conform to ASTM A615.15
- .2 Shall be provided by Williams Form Hardware and Rockbolt Ltd.

2.2 Posts

- .1 The four [4] piles shall be 3" by 1/4" Postech sleeve pile extensions.

2.3 Grout

- .1 Grout shall supplied by Williams Form Hardware and Rockbolt Ltd.
- .2 Shall be compatible will the all-thread rod, and as recommended by Williams Form

2.4 Mechanical Rock Anchors:

- .1 Shall be Williams Form HC16 mechanical rock anchors.
- .2 Alternates will not be considered.

PART 3 - EXECUTION

3.1 Installation

- .1 Installation shall be carried out as per the installation directions on the appended drawings.
- .2 The location for jig placement will be determined by on-site CCG staff.
- .3 The elevation of the top steel plate of the pier will be as determined on-site by CCG staff
- .1 Provisions shall be made to allow for variance in the lengths of the drilled and tensioned steel piles from that of the drawings, based on water depth and field conditions.



SECTION: 133613 METAL TOWERS

PART 1 - GENERAL

1.1 Scope of Work

- .1 Work under this section includes the supply of all labour, material, and equipment required to complete:
 - .1 Transportation of the tower and all associated hardware to site from the designated staging area;
 - .2 The installation of the tower detailed in the appended Contract Drawings;
 - .3 The installation of a self-contained lantern on to the tower, and confirmation of proper operation.
- .2 Work of this section excludes:
 - .1 Fabrication and supply of the tower.
 - .2 Supply of the navigational lantern.

1.2 References

- .1 Work under this section shall be undertaken in strict conformance with all listed references. In the case of any conflict or discrepancy the more stringent requirements shall apply.
 - .1 Canada Labour Code Part II.
 - .2 NRC-CNRC National Building Code of Canada.
 - .3 CSA S37-01 - Antenna Towers and Antenna Supporting Structures.
 - .4 CAN/CSA S16.1 - Limit States Design of Steel Structures.
 - .5 CAN/CSA G164 - Hot Dip Galvanizing of Irregularly Shaped Articles.

1.3 Submittals

- .1 No submittals required in this section

1.4 Quality Assurance

- .1 Coast Guards minimum inspection requirements are detailed below. The Contractor shall be responsible to notify Coast Guard of the date and time that the works may be inspected. Notice must be provided no less than three (3) working days in advance to permit scheduling of quality assurance testing. All deficiencies in the works identified at the time of inspection shall be remedied to the satisfaction of Coast Guard, by the Contractor at their expense. Work shall not progress until inspections have been completed and the Contractor has been provided with written notice to proceed with the works:



- .1 Upon completion of the work to ensure tower is plumb and that light is operating correctly;

PART 2 - PRODUCTS

2.1 Materials

.1 Steel:

- .1 The tower is structural grade steel 350W and 300W.

.2 Coatings:

.1 Galvanizing:

- .1 All materials, structural steel, pipe and fittings, including bolts, nuts and washers shall be hot dip galvanized to the requirement of the National Building Code, CAN/CSA S16.1, and CSA-G164 and as otherwise specified therein.

.3 Bolts, Nuts, Washers:

- .1 Contractor shall supply four [4] structural grade A325 bolts including double heavy hex nut hardware, hot dip galvanized, to attached the tower base to the steel plate included in the pier design .

PART 3 - EXECUTION

3.1 Fabrication

- .1 Fabrication has been completed by the Canadian Coast Guard. This includes everything shown on the drawing which comprises the tower.

3.2 Protective Coatings

.1 Galvanizing:

- .1 The tower and all hardware are hot dip galvanized. The contractor shall be prepared to make repairs to the coating as needed.

3.3 Handling of Material and Transportation

- .1 Estimated weight of the tower is 375 kg (825 lbs).
- .2 The Contractor shall take all necessary precautions to avoid damage to the tower members or to tower coating during transport, unloading and erection. All components or damaged members shall be replaced to the satisfaction of Coast Guard at the expense of the Contractor.
- .3 It is the responsibility of the Contractor to ensure that the tower sections, particularly the joints are protected from bending and alignment damage.
- .4 The contractor will be asked to identify how he would like the tower packaged for shipping shortly after award. This will be coordinated by CCG.



Fisheries and Oceans
Canada

Pêches et Océans
Canada

Canadian
Coast Guard

Garde côtière
canadienne



3.4 Bolting the tower to the steel plate

- .1 The tower shall be bolted down to the pier's base plate plate using four [4] structural grade A325 bolts (galvanized). No leveling nuts are to be used.
- .2 Each bolt shall have two [2] heavy hex nuts (galvanized).
- .3 Contractor shall tighten the first nut using turn of nut method associated to the length of bolt provided. The second nuts shall be snug tight to lock into place the two nuts.



Fisheries and Oceans
Canada

Pêches et Océans
Canada

Canadian
Coast Guard

Garde côtière
canadienne



APPENDIX B1: SITE LOCATION AND PHOTOGRAPHS

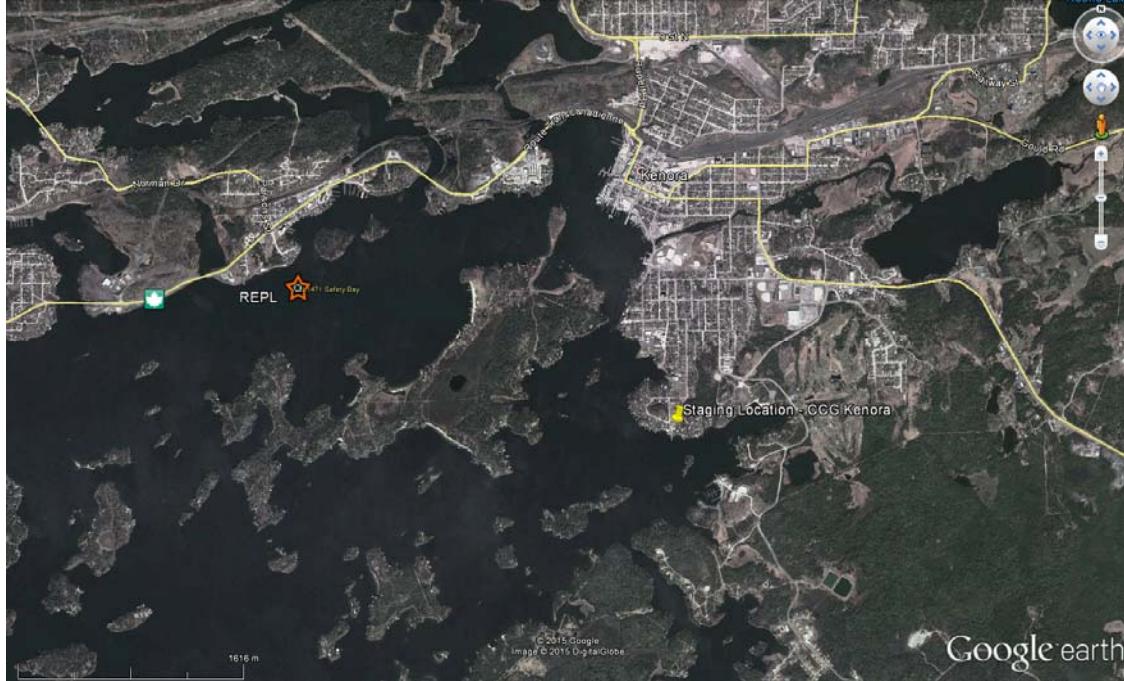

LL 1471 Safety Bay 49°45'34.73"N 94°31'24.19"W

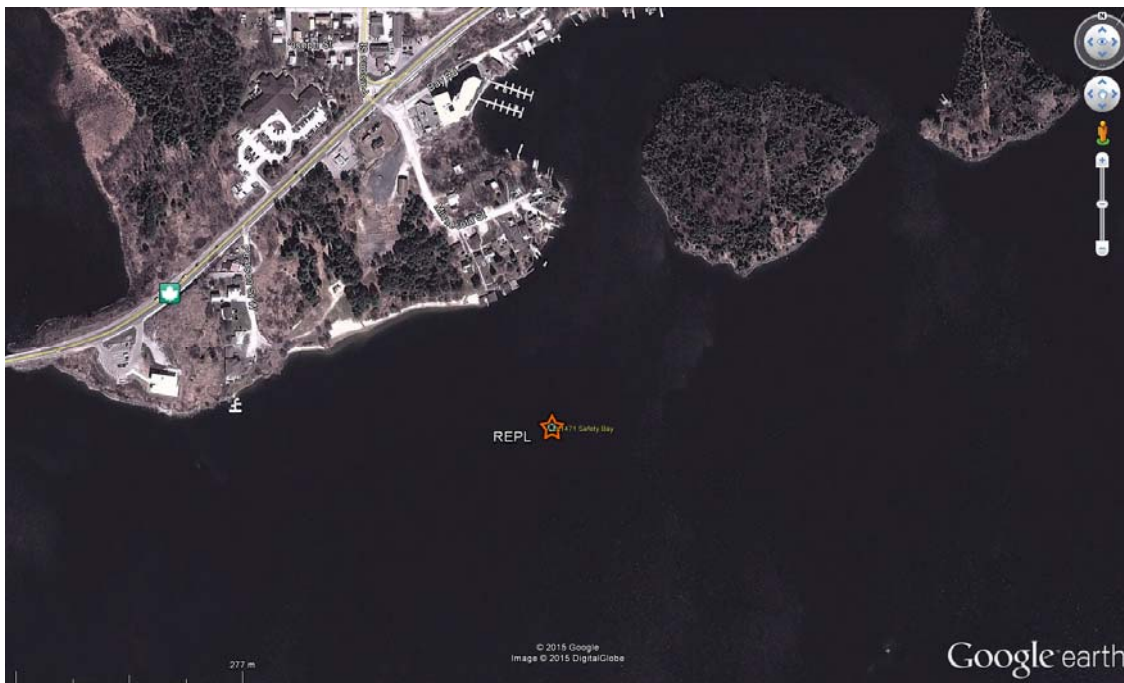

Project Site



Fisheries and Oceans
Canada

Pêches et Océans
Canada

Canadian
Coast Guard

Garde côtière
canadienne



Existing ATON, Tower and appurtenances to be salvaged



Existing ATON



Fisheries and Oceans
Canada

Pêches et Océans
Canada

Canadian
Coast Guard

Garde côtière
canadienne



Existing concrete pier (extends below waterline)
Concrete to be removed to bedrock elevation



Existing concrete pier, exposed reinforcing steel to be cut flush to bedrock elevation



APPENDIX B2 – SUMMARY OF SUBMITTALS

Following Contract Award	
Submission Description	Section(s)
Deadline: 10 working days following award	
Detailed schedule:	<i>011100</i>
Proof of qualifications:	
a) Proof of Vessel Registration	<i>011100</i>
Deadline: 10 working days prior to mobilization	
Construction Plan	
a) Project specific safety plan	<i>011100</i>
b) Project environmental protection program	<i>011100</i>
c) Detailed demolition plan	<i>024116</i>
d) Drilling plan	<i>055000</i>
Deadline: 21 calendar days following acceptance of the works	
Waste disposal receipts	<i>024116</i>
As-built drawings	<i>055000</i>



Fisheries and Oceans
Canada

Pêches et Océans
Canada

Canadian
Coast Guard

Garde côtière
canadienne



APPENDIX B3 – DRAWINGS

REVISIONS

#	DATE	BY	DESCRIPTION
A	07/13/15	PB	ISSUED FOR BUILD/INSTALL

THESE DRAWINGS ARE NOT TO BE SCALED AND IN THE CASE OF A DISCREPANCY PLEASE CONTACT GRANITE ENGINEERING SERVICES PRIOR TO CONSTRUCTION

THIS DRAWING CONTAINS CONFIDENTIAL INFORMATION AND SHALL NOT BE REPRODUCED OR DISCLOSED WITHOUT THE WRITTEN CONSENT OF GRANITE ENGINEERING SERVICES

OWNER TO CONTACT GES TO PRE-DEFINE SITE REVIEW TIMES. FAILURE TO CONTACT GES COULD ALLEVIATE GES OF ANY/ALL RESPONSIBILITY FOR THIS PROJECT

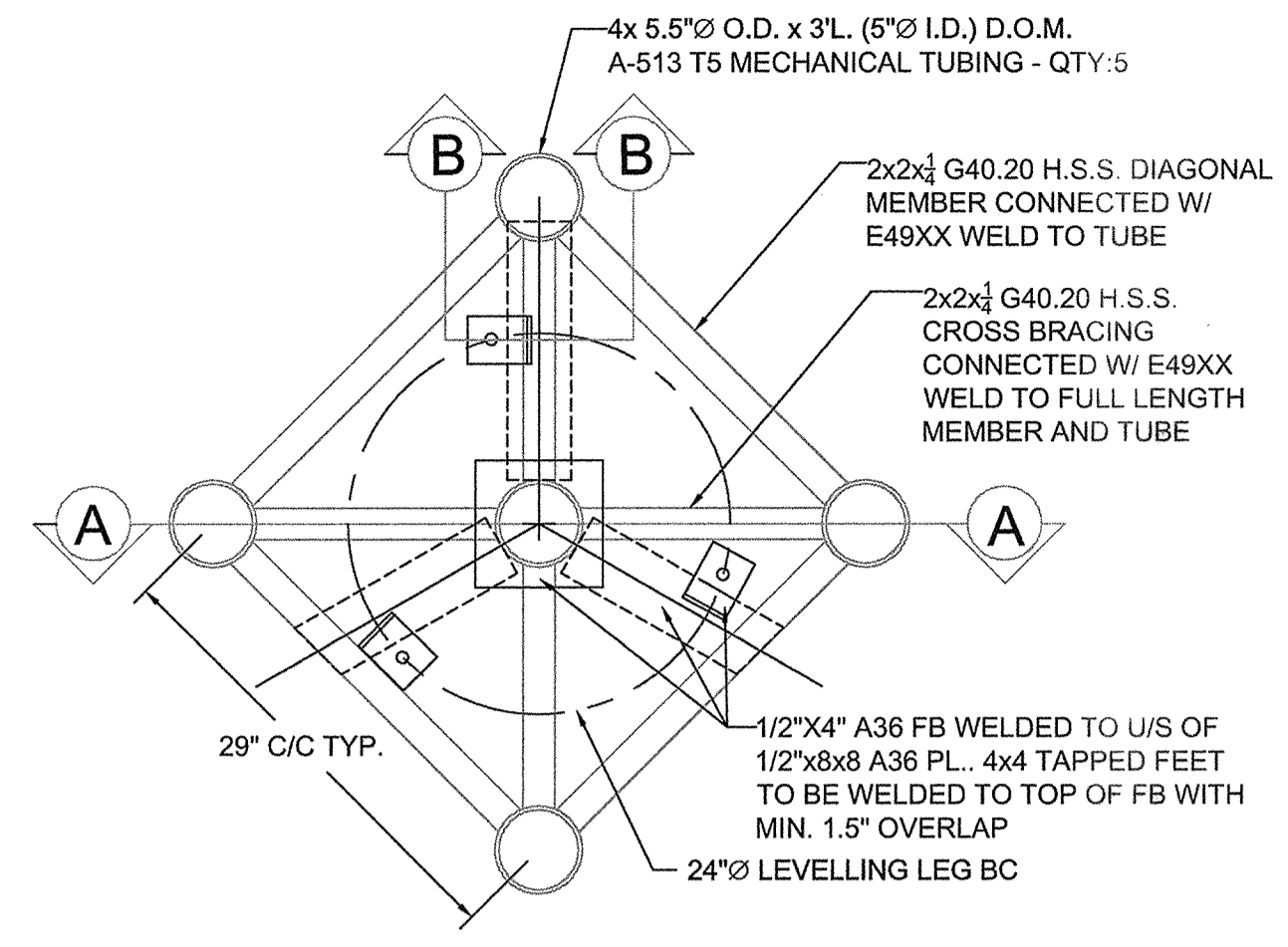

4 JIG PLAN VIEW
S-1 1-1/2"=1'-0"

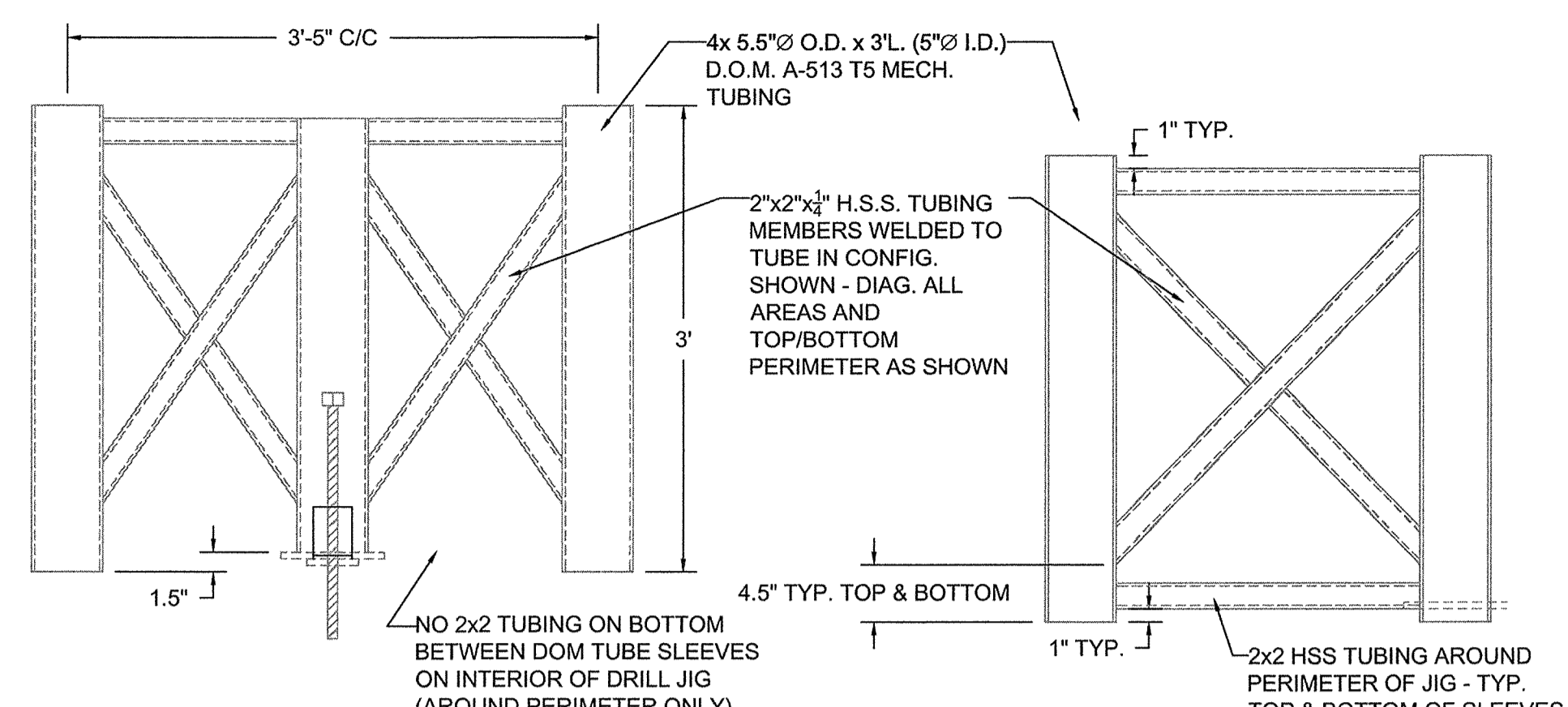

5 SECTION A-A VIEW
S-1 1-1/2"=1'-0"

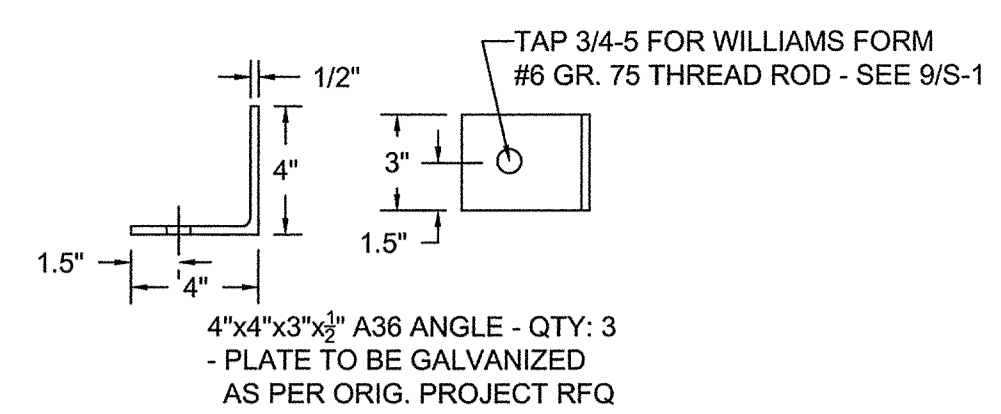

8 LEVELING FEET
S-1 1/2"=1'-0"

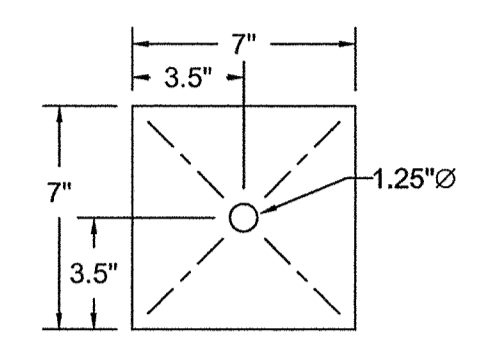

7 CUSTOM WASHER
S-1 1/2"=1'-0"

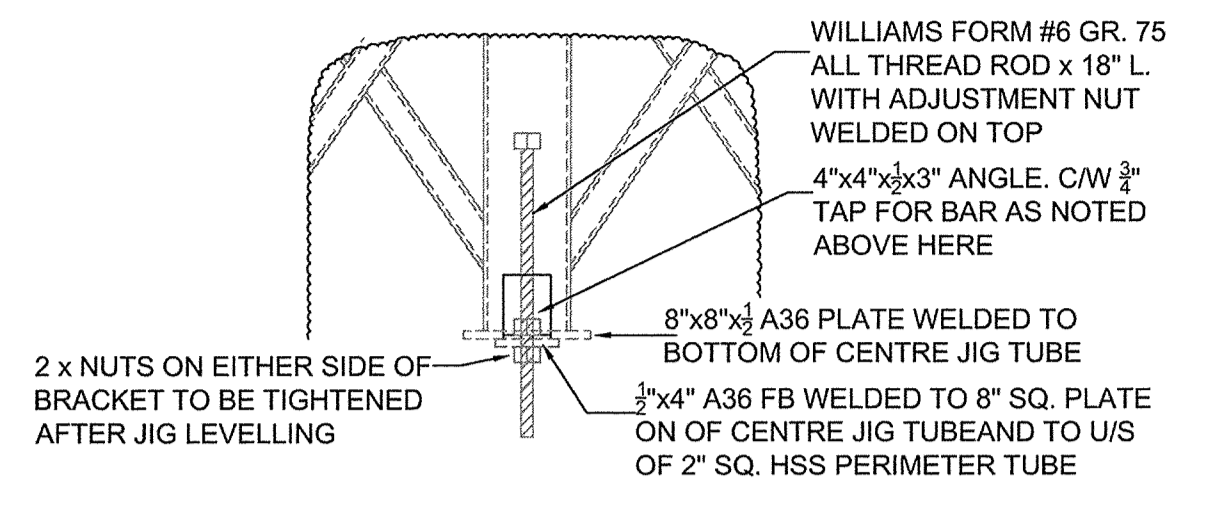

9 SECTION B-B VIEW - TYP. X 3
S-1 1-1/2"=1'-0"

JIG BUILD DETAILS

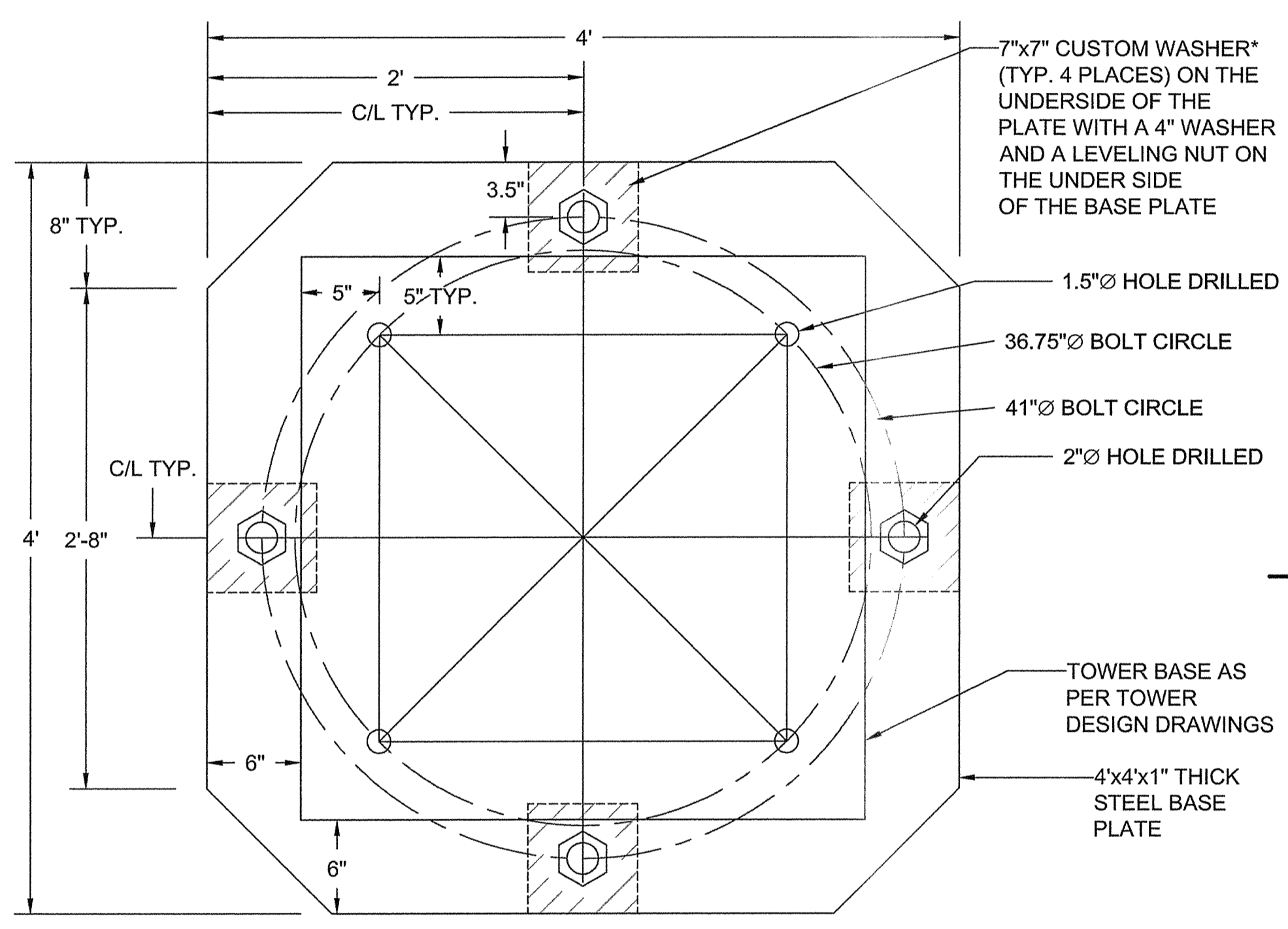

1 BASE PLATE DETAIL
S-1 1/4"=1'-0"

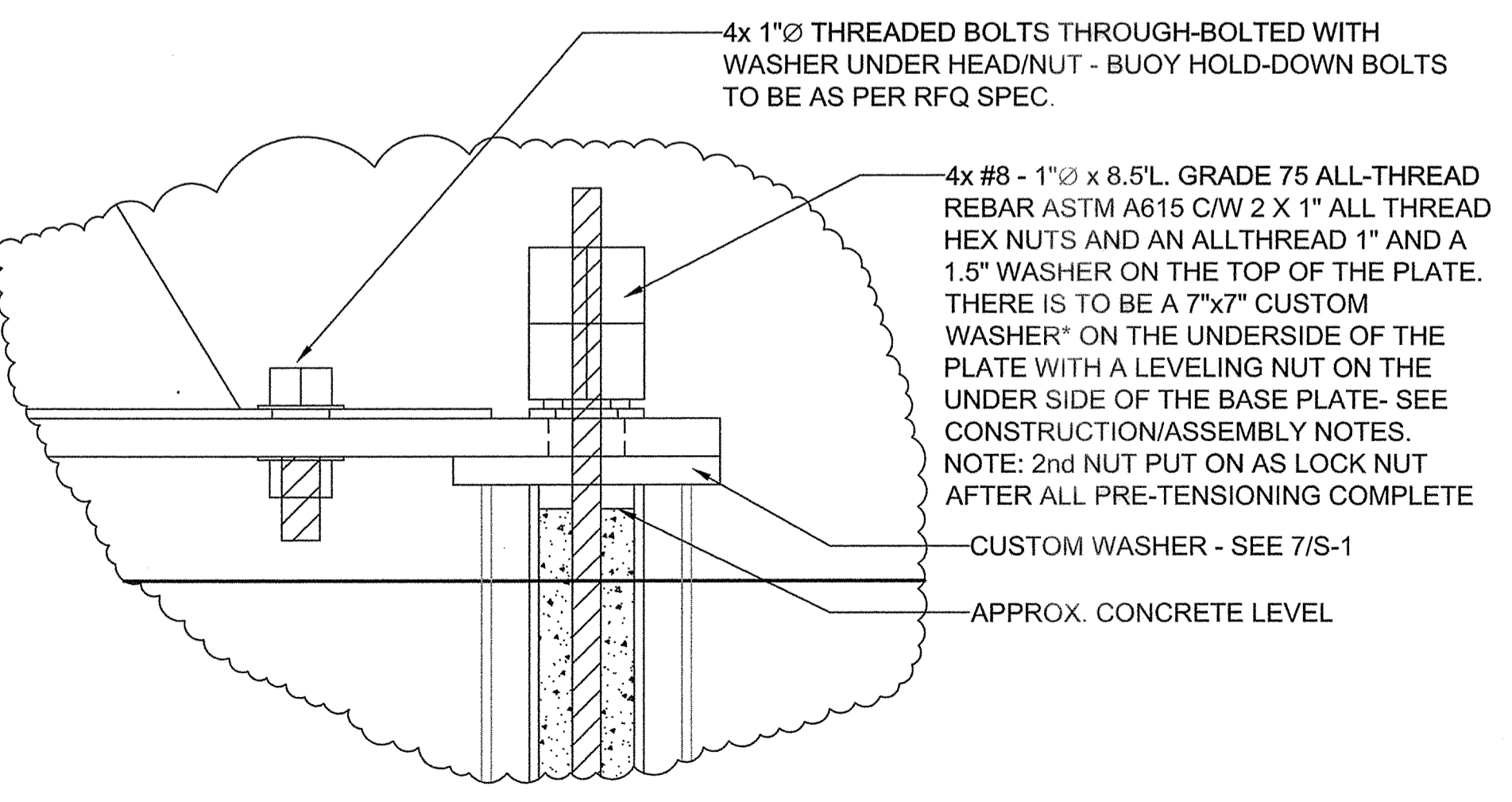

10 PLATE TO PILE ASSEMBLY
S-1 1/2"=1'-0"

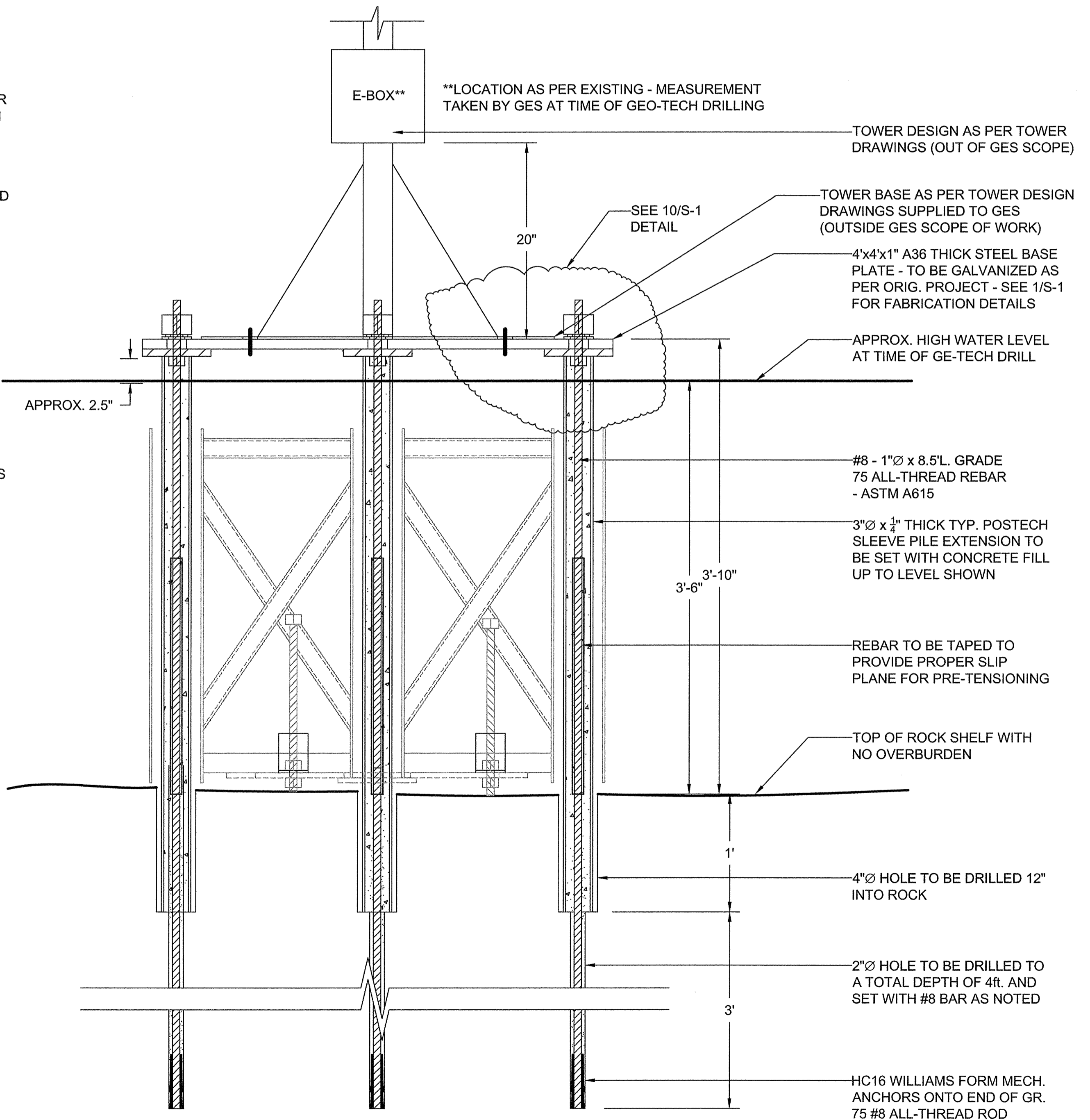

3 PROPOSED TOWER ANCHORING DETAILS
S-1 1/4"=1'-0"

ORDER OF OPERATIONS/ASSEMBLY NOTES:

1. LOCATE JIG POSITIONING AS PER CONFIRMATION BY COAST GUARD TO GES DURING TESTING PERIOD.
2. SET/LEVEL JIG USING LEVELING THREAD RODS - AS SHOWN IN 4/S-1, 7/S-1, AND 9/S-1 DETAILS.
3. DRILL 4" HOLE TO A 12" DEPTH. AS PER DETAIL 3/S-1, THEN TREMIE FILL IN APPROXIMATELY 1' DEEP WITH S6Z WIL-X QUICK SET GROUT, SET 3.5" POSTECH SLEEVES AND WORK TO BOTTOM OF DRILLED HOLE WHILE GROUT IS WET, AND LET HARDEN FOR 1-2 HOURS. AFTER GROUT SET-UP, THEN CUT ALL SLEEVES LEVEL AND SPRAY WITH GALV. PAINT.
4. THEN DRILL 2" HOLE TO REQUIRED DEPTH - AS PER DETAIL 3/S-1
5. FLUSH DRILL HOLES WITH WATER UNTIL CLEAR OF DEBRIS.
6. ATTACH HC16 MECH. ANCHOR TO BOTTOM OF #8 GR. 75 ALL-THREAD ROD AND SET TO BOTTOM OF 2" HOLES. THEN FILL ALL SLEEVES TO WITHIN 1" OF TOP OF SLEEVE WITH GROUT, SET 4" SQ. PLATE INTO PLACE, AND TORQUE ALL 4 x #8 ANCHORS TO 400 FT-LBS WITH IMPACT GUN AND TORQUE WRENCH WHILE GROUT IS STILL WET. ENSURE #8 THREAD ROD IS TAPED AS SHOWN IN 3/S-1 BEFORE SETTING INTO DRILL HOLES.
7. BUOY MOUNTING PLATE/BUOY CAN THEN BE MOUNTED ONTO 1" PLATE WITH HARDWARE AS NOTED IN 10/S-1.

GES SCOPE OF WORK-GEO-TECH- BARGE SECURING NOTES:

1. THE TOWER DESIGN IS OUT OF THE GES SCOPE OF WORK.
2. DEPTHS FOR DRILLING AND ANCHORAGE WERE DETERMINED BASED ON GEO-TECHNICAL DRILLING/INVESTIGATION OF THE SITE. GEO-TECHNICAL "DRILLING"/CORE SAMPLES WERE COLLECTED BY ON-SITE DRILLING ON JUNE 8, 2015. DESIGN WAS BASED ON THE DRILL RESULTS FROM JUNE 8, 2015.
3. THE BARGE IS TO BE SECURED WITH SPUDS AND THE HYDRAULIC BARGE RAMPS PRIOR TO THE COMMENCEMENT OF ALL DRILLING. SEE "ORDER OF OPERATIONS/ASSEMBLY NOTES" FOR INSTALLATION PROCEDURE.

ALL COMPONENTS OF THE DRILLING TEMPLATE/JIG ARE TO BE WELDED TOGETHER BY A CWB CERTIFIED WELDER USING A 3/16" FULL ROUND FILET WELD. COPIES OF FABRICATORS CWB CERTIFICATION TO BE FORWARDED TO GES

ALL EXPOSED METAL MEMBERS, PARTS, FASTENERS ARE TO BE GALVANIZED AS PER RFQ PROJECT #: EWTM 8010-1380000 APPENDIX B DRAWINGS PAGE 3. FABRICATE "JIG ASSEMBLY" AND INDIVIDUAL COMPONENTS AS NOTED HERE, THEN SEND ASSEMBLY AND INDIVIDUAL COMPONENTS OUT FOR GALVANIZING

ALL-THREAD BAR, NUTS, WASHERS, MECHANICAL ANCHORS, AND GROUT TO BE SOURCED FROM: WILLIAMS FORM HARDWARE & ROCKBOLT LTD., 670 INDUSTRIAL ROAD, LONDON, ONT., PH: (519) 659-9444.

DUE TO THE EFFECT THAT PASSING BOAT TRAFFIC HAD ON THE BARGE MOVEMENT, GES HIGHLY RECOMMENDS THAT THE INSTALLATION OF THIS BUOY TAKE PLACE AFTER THE LABOUR DAY WEEKEND OR BEFORE JUNE 1ST IN ORDER THAT PASSING BOAT TRAFFIC IS MINIMIZED.



SCALE AS NOTED
DATE JULY 13/15
DRAWN BY S.A.K. CHECKED BY P.B.B.
PROJECT No. 0608-515
PROJECT TITLE

COAST GUARD SAFETY BUOY
GULL ROCK SHOAL, LAKE MUSKOKA
44D 59M 00S N 79D 29M 17S W
ONTARIO

CONTRACTOR T.B.D.

REV.	SHEET	SHEET No.
A	1 of 1	S-1

4

3

2

1

B

B

A

A

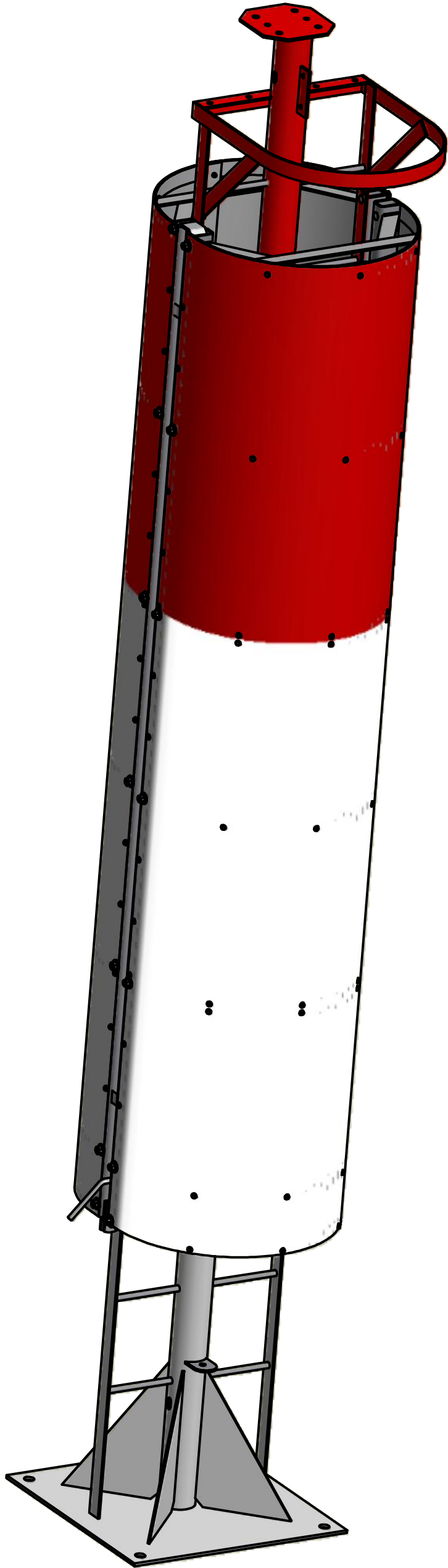

 Fisheries and Oceans Canada	Pêches et Océans Canada
Canadian Coast Guard Centre de l'Arctique	Garde côtière canadienne Région du centre et de l'ouest
Maritime and Coastal Infrastructure Infrastructure maritime	Integrated Technical Services Services techniques intégrés

16 FT PIPEMAST ANTI-CLIMB

FILE No. EWTM 8010-6-1		SCALE: N.T.S.	DWG No.	
Rv.	DATE	DESCRIPTION	DRAWN	APP'D
0	29 FEB 12	DRAWING INITIATED	A.J.E.	A.W.W.
1	23 MAR 12	FOR PRODUCTION	A.J.E.	A.W.W.
2	27 JUN 12	SHEET THICKNESS REDUCED	M.H.	B.Y.
3	04 JAN 13	P1 MODIFIED AND S2 CREATED	M.H.	B.Y.
4	11 JAN 13	FINAL DRAWING COMPLETED	E.J.G.	B.Y.

4

3

2

1

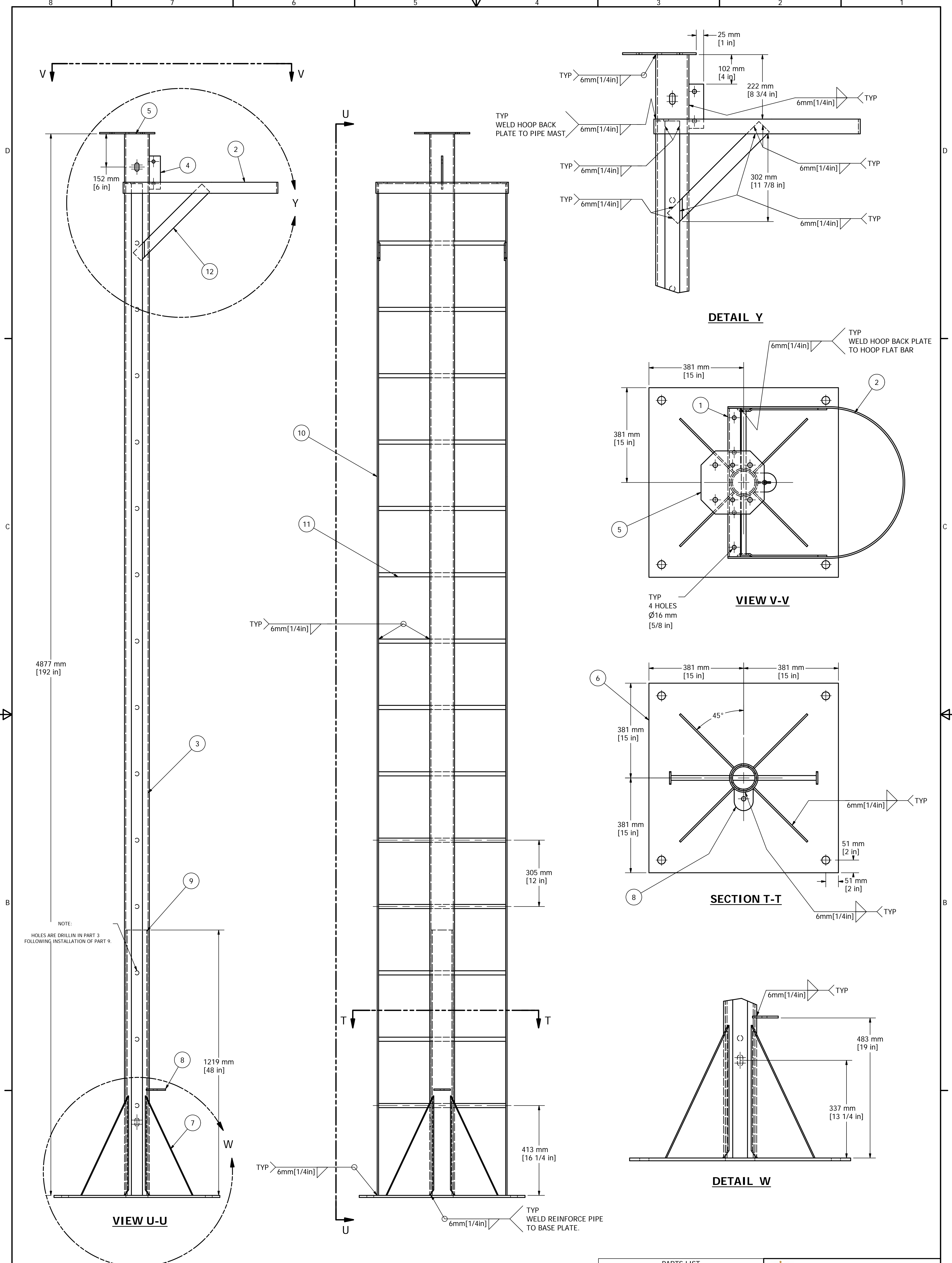

NOTE:
HOLES ARE DRILLIN IN PART 3
FOLLOWING INSTALLATION OF PART 9.

STRUCTURAL NOTES:

1. STEEL DESIGN, FABRICATION, AND ERECTION: CAN/CSA-S16.1 AND CSA-S136, UNLESS OTHERWISE NOTED.
2. ALL STRUCTURAL MEMBERS SHOWN ARE NEW.
3. ALL STRUCTURAL STEEL IS TO BE NEW AND CONFORM TO: CSA G40.21M, GRADE 350W, UNLESS OTHERWISE NOTED.
5. WELDED STEEL CONSTRUCTION (METAL AND ARC WELDING) SHALL CONFORM TO CSA W59-M AND IS TO BE UNDERTAKEN BY A FABRICATOR CERTIFIED TO CSA STANDARD W47.1 FOR DIVISION 1 OR 2.1.
6. STEEL FABRICATOR IS RESPONSIBLE TO ENSURE THAT STRUCTURAL COMPONENTS AND WELDS ARE NOT OVER STRESSED DURING FABRICATION AND CONSTRUCTION.
7. HOT DIP GALVANIZING SHALL CONFORM TO CAN/CSA-G164.
8. DO NOT SCALE DRAWINGS.
9. ANCHORAGE BY OTHERS.

PARTS LIST		
ITEM	QTY	PART
1	1	Hoop Back Plate
2	1	Hoop Flat Bar 1
3	1	Pipe Mast 16'
4	1	Fall Arrest Bracket
5	1	Cap Plate
6	1	Base Plate
7	4	Gusset Plate
8	1	Fall Arrest Tension Bracket
9	1	Reinforce Pipe
10	2	Side Rails 16'
11	14	RungLong
12	2	Hoop Support Flat Bar

Fisheries and Oceans Canada
Central & Arctic Region
Maritime and Civil Infrastructure (MCI), Integrated Technical Services
520 Exmouth St., Sarnia, ON, N7T 8B1

Pêches et Océans Canada
Région du centre et de l'Arctique
Garde côtière canadienne

16 ft PIPE MAST FABRICATION DETAILS

FILE No.	EWTM-8010-6	SCALE:	DWG No.	
			1 of 5	
Rv.	DATE	DESCRIPTION	DRAWN	APP'D
0	03 MAR 12	DRAWING INITIATED	R.C.S.	R.C.S.
1	13 JAN 12	FOR PRODUCTION	A.J.E.	A.W.W.
2	13 MAR 12	PRODUCTION WITH LIMITATIONS	A.J.E.	A.W.W.
3	19 APR 12	ADDITION OF 16/20 PMST - REDLINES	A.J.E.	A.W.W.

4

3

2

1

PARTS LIST				
PART NO.	QTY	PART	DESCRIPTION	DRAWING NO.
A1	1	DOOR OF ANTI-CLIMB	SEE ASSEMBLY	3
A2	1	BACK OF ANTI-CLIMB	SEE ASSEMBLY	4
S1	2	RIBBING SKELETON SUB-ASSEMBLY	SEE SUB-ASSEMBLY	5
S2	10	RIBBING SUB-ASSEMBLY	SEE SUB-ASSEMBLY	6
S3	2	TOP RIBBING SUB-ASSEMBLY	SEE SUB-ASSEMBLY	7
S4	2	BOTTOM RIBBING SUB-ASSEMBLY	SEE SUB-ASSEMBLY	8
S5	1	LATCH SUB-ASSEMBLY	6 X 57mm[1/4 X 2 1/4in] FLAT BAR	9
P1	4	MALE HINGE	SEE PART	10
P2	4	FEMALE HINGE	SEE PART	11
P3	14	STANDARD RIB BRACING	6 X 51mm[1/4 X 2in] FLAT BAR	12
P4	8	DIAGONAL RIB BRACING	6 X 51mm[1/4 X 2in] FLAT BAR	12
P5	2	SECONDARY RIB BRACING	6 X 51mm[1/4 X 2in] FLAT BAR	12
P6	14	RIB	6 X 51mm[1/4 X 2in] FLAT BAR	13
P7	1	LATCH HOOK	SEE PART	14
P8	1	HANDLE	16mm[5/8in] ROUND BAR	15
P9	2	SHEETING	6 X 1254 X 1245mm[1/8 X 49 3/8 X 49in] SHEET - RED	16
P10	2	SHEETING	6 X 1254 X 1219mm[1/8 X 49 3/8 X 48in] SHEET - WHITE	16
P11	2	SHEETING	6 X 1254 X 813mm[1/8 X 49 3/8 X 32in] SHEET - WHITE	16
P12	1	DOOR REST	6 X 51mm[1/4 X 2in] FLAT BAR	17
P13	2	HSS VERT	129in LONG 6 X 51 X 76mm[1/4 X 2 X 3in] RECTANGULAR TUBE	18
P14	2	HSS VERT WITH HOLE	129in LONG 6 X 51 X 76mm[1/4 X 2 X 3in] RECTANGULAR TUBE	19
P15	1	RUBBER STOPPER	SEE PART	20
P16	2	SQUARE STOPPER	SEE PART	21
P17	2	TALL RIB REINFORCEMENT	6 X 51mm[1/4 X 2in] FLAT BAR	22

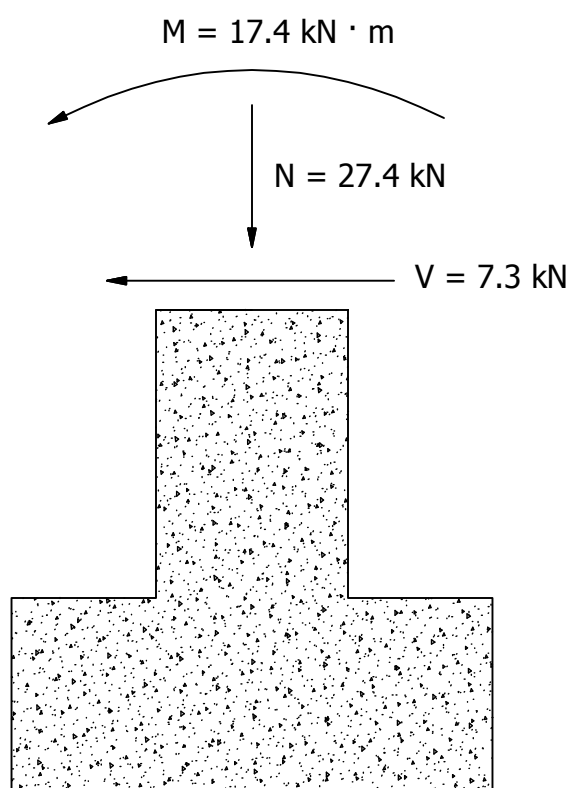

16' PIPEMAST FOUNDATION LOADS

STRUCTURAL NOTES:

1. WIND PRESSURE OF 600Pa WAS USED IN CALCULATING FACTORED LOAD COMBINATIONS. ICE THICKNESS OF 50mm WAS USED IN CALCULATING LOADING PER S37-01, ICE CLASS IV. ALL LOADS WERE FACTORED PER NBCC 2010
2. ALUMINUM ALLOYS SHALL CONFORM TO THE 'ALUMINUM ASSOCIATION' PUBLICATION 'ALUMINUM STANDARD AND DATA' AND HAVE A MINIMUM YIELD STRENGTH OF 240 MPa, GRADE 6061-T6.
3. ALL STRUCTURAL MEMBERS SHOWN ARE NEW.
4. METAL AND ARC WELDING SHALL CONFORM TO CSA W59.2 AND IS TO BE UNDERTAKEN TO CSA W47.2 DIVISION 1, 2.1, OR 2.2.
5. ENSURE THAT STRUCTURAL COMPONENTS AND WELDS ARE NOT OVER STRESSED DURING CONSTRUCTION.
6. FASTENERS SHALL BE GALVANIZED STEEL BOLTS A325 OR GREATER.
7. LARGE B/W/N REFERS TO A BOLT WASHER AND NUT ASSEMBLY CONSISTING OF 18-8 STAINLESS STEEL 1/2" X 4" ROUND HEAD CARRIAGE BOLT, 1/2" SMALL OD FLAT WASHER (1 1/4" OD) AND 1/2" NYLON INSERT LOCK NUT
8. SMALL B/W/N # 1 REFERS TO A BOLT WASHER AND NUT ASSEMBLY CONSISTING OF 18-8 STAINLESS STEEL 3/8" X 1" HEX CAP SCREW, 3/8" SMALL OD FLAT WASHER (1" OD) AND 3/8" NYLON INSERT LOCK NUT
9. SMALL B/W/N # 2 REFERS TO A BOLT WASHER AND NUT ASSEMBLY CONSISTING OF 18-8 STAINLESS STEEL 3/8" X 3/4" HEX CAP SCREW, 3/8" SMALL OD FLAT WASHER (1" OD) AND 3/8" NYLON INSERT LOCK NUT
10. UNLISTED BOLTS ARE 18-8 STAINLESS STEEL WITH NYLON INSERT LOCK NUTS
11. DRAWINGS NOT TO SCALE.

 is: eries and ceans Canada Canadian Coast Guard Centra arctic e: ion artile and Cl in rastructure out it: amia		é: es et céans Canada Garde côtière canadienne é: ion du centre et de rti: ue C: é: nte: rated ec: nica: er: ices		
16 FT PIPEMAST ANTI-CLIMB				
FILE No.	EWTM 8010-6-1	SCALE:	N.T.S.	
		DWG No.	0	
Rv.	DATE	DESCRIPTION	DRAWN	APP'D
0	29 FEB 12	DRAWING INITIATED	A.J.E.	A.W.W.
1	23 MAR 12	FOR PRODUCTION	A.J.E.	A.W.W.
2	27 JUN 12	SHEET THICKNESS REDUCED	M.H.	B.Y.
3	04 JAN 13	P1 MODIFIED AND S2 CREATED	M.H.	B.Y.
4	11 JAN 13	FINAL DRAWING COMPLETED	E.J.G.	B.Y.

4

3

2

1

4 3 2 1

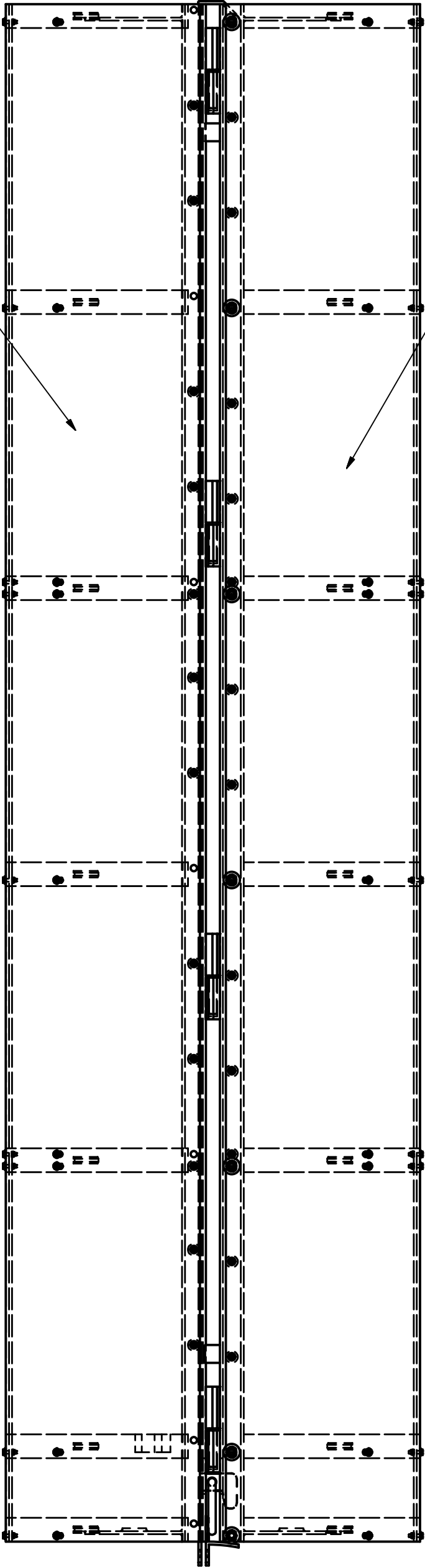

VIEW A-A

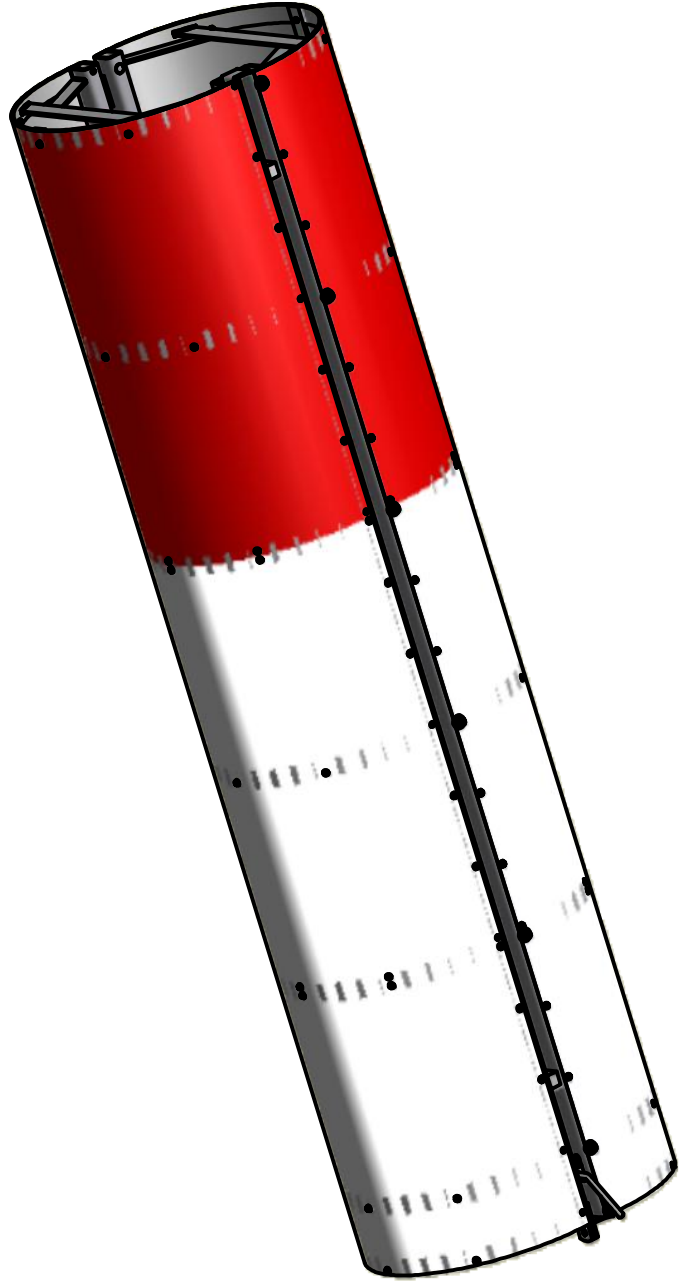
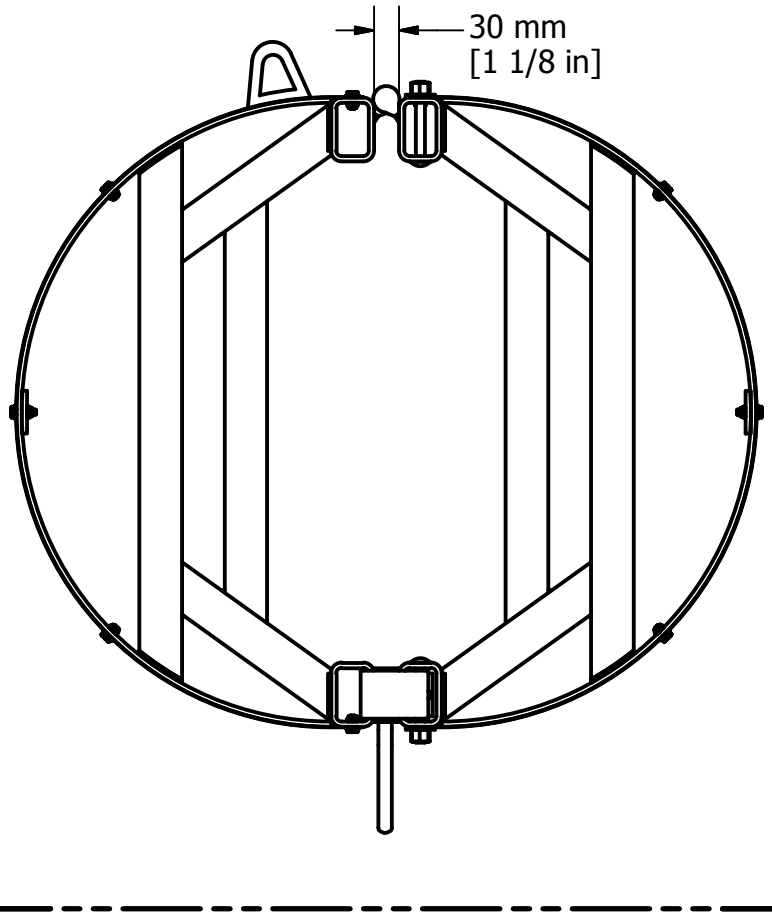

 Fisheries and Oceans Canada
 Canadian Coast Guard
 Centre of Arctic Operations
 Maritime and Coastal Infrastructure
 Integrated Technical Services
 Services et pêches Canada
 Garde côtière canadienne
 Opérations du centre et de l'Arctique
 Infrastructure côtière et maritime
 Services techniques intégrés

16 FT PIPEMAST ANTI-CLIMB
TOTAL ANTI-CLIMB ASSEMBLY

Rv.	DATE	DESCRIPTION	DRAWN	APP'D
0	29 FEB 12	DRAWING INITIATED	A.J.E.	A.W.W.
1	23 MAR 12	FOR PRODUCTION	A.J.E.	A.W.W.
2	27 JUN 12	SHEET THICKNESS REDUCED	M.H.	B.Y.
3	04 JAN 13	P1 MODIFIED AND S2 CREATED	M.H.	B.Y.
4	11 JAN 13	FINAL DRAWING COMPLETED	E.J.G.	B.Y.

4 3 2 1

4

3

2

1

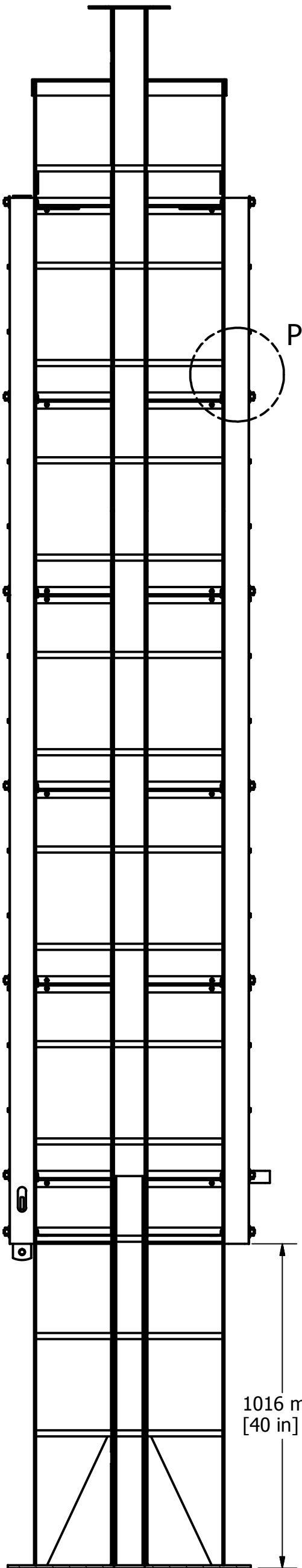

SECTION O-O

1016 mm
[40 in]

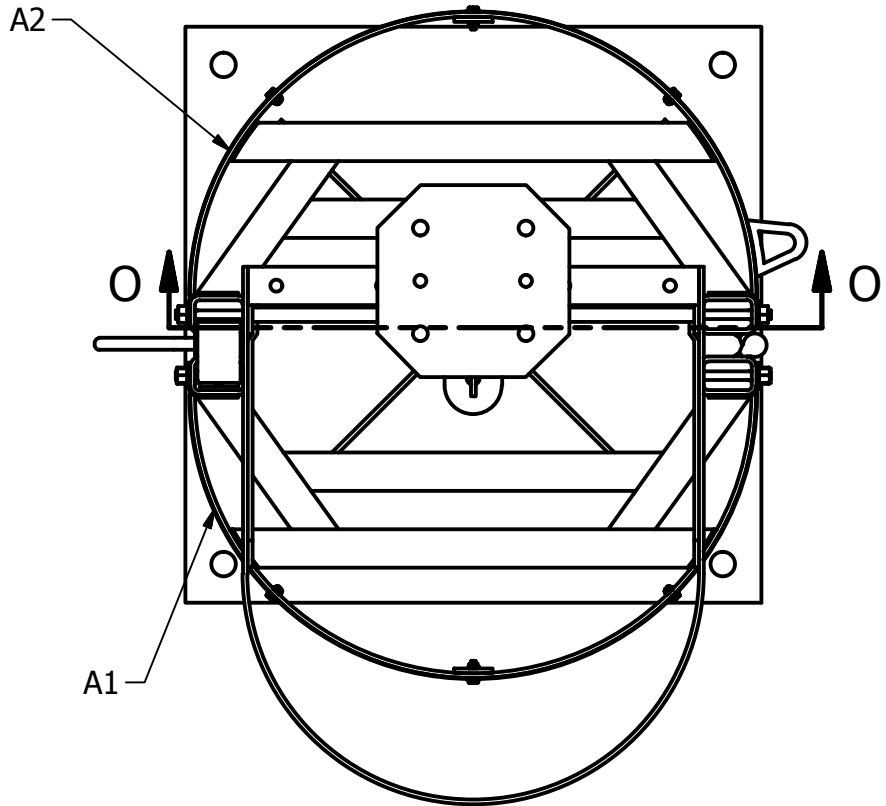

LARGE B/W/N THROUGH HSS
AND LADDER SIDE BAR HOLDING
ANTI-CLIMB BACK TO PIPEMAST

LADDER RUNG

STANDARD RIB

DETAIL P - TYP MOUNTING OF
ANTI-CLIMB CAGE

 Fisheries and Oceans Canada
 Canadian Coast Guard
 Centre of Excellence
 Maritime and Coastal Infrastructure
 Integrated Technical Services
 Outcomes

16 FT PIPEMAST ANTI-CLIMB
MOUNTING INSTRUCTIONS

FILE No.	EWTM 8010-6-1	SCALE:	N.T.S.	DWG No.	2
Rv.	DATE	DESCRIPTION	DRAWN	APP'D	
0	29 FEB 12	DRAWING INITIATED	A.J.E.	A.W.W.	
1	23 MAR 12	FOR PRODUCTION	A.J.E.	A.W.W.	
2	27 JUN 12	SHEET THICKNESS REDUCED	M.H.	B.Y.	
3	04 JAN 13	P1 MODIFIED AND S2 CREATED	M.H.	B.Y.	
4	11 JAN 13	FINAL DRAWING COMPLETED	E.J.G.	B.Y.	

4

3

2

1



Fisheries and Oceans
Canada

Pêches et Océans
Canada

Canadian
Coast Guard

Garde côtière
canadienne



APPENDIX B4 – MARINE ACCESS REQUIREMENTS

.1 Marine Access

- .1 Vessel(s) employed in the performance of the contract shall be certified as required by the Canada Shipping Act 2001 and its applicable regulations including Marine Personnel Regulation.
 - .1 The bidder shall ensure that the vessel(s) proposed for the work meets all requirements of the Canada Shipping Act 2001 and the applicable Regulations under the Canada Shipping Act.
 - .2 Bidders shall provide copies of the following documentation to facilitate evaluation and award:
 - .1 Proof of vessel registration as a commercial vessel in accordance with the Canada Shipping Act 2001. Either one of two registrations will be accepted:
 - .1 Proof of commercial vessel registration in the Small Vessel Register (SVR) if less than 15 Gross Tons or;
 - .2 Proof of commercial vessel registration in the Canadian Register of Vessels (CRV) if more than 15 Gross Tons.
 - .3 NOTE: Pleasure Craft and Fishing Vessels are not acceptable for the performance of this work – it must be a commercially registered vessel.
 - .2 Where the vessel is registered in the SVR the bidder shall also provide the following:
 - .1 Copy of vessel certification and any limitations the vessel is operating under. Where the vessel is restricted, the operator shall ensure that the vessel can be used to safely perform the work in this specification;
 - .2 Copy of inspection according to the Small Vessel Compliance Program; Bidder shall submit proof of enrolment in the compliance program and;
 - .3 Either a copy of the initial inspection report or the most recent copy of an annual inspection report and;
 - .4 Copy of the crew certification that will be operating the vessel. Crewing and certification of crew shall be in accordance with the Marine Personnel Regulations, latest edition.
 - .3 Where the vessel is registered in the CRV the bidder shall also provide the following:
 - .1 Copy of the latest Annual Inspection Certificate endorsement and;

- .2 Copy of any restrictions that the vessel is operating under and the general sailing limitations of the vessel. Where the vessel is restricted, the operator shall ensure that the vessel can be used to safely perform the work in this specification;
 - .3 Copies of the crew certification that will be operating the vessel. Crewing and certification of crew shall be in accordance with the Marine Personnel Regulations, latest edition.
- .2 Vessels and crew found to be in contravention of the act will not be permitted to be engaged in any elements of the works identified herein. In the event that a vessel or crew is found non compliant a suitable replacement vessel and/or crew will be retained by the Contractor at their sole expense.