





## **AMENDMENT #4**

**THE PUPOSE OF THIS AMENDMENT IS TO UPDATE SECTION 06 10 00.01 – CARPENTRY WITH TREATED WOOD OF THE SPECIFICATIONS (1) AND TO ANSWER QUESTIONS ASKED BY POTENTIAL (2).**

**1. SPECIFICATION UPDATE:**

**SECTION 06 10 00.01 – CARPENTRY WITH TREATED WOOD**

SEE ENCLOSED ATTACHMENT ``Addendum``: 631689-0001-40BN-EN04\_00.

**2. Technical Questions and Answers n° 4**

Question 1: In Section 06 10 00.01 Wood, Plastics and Composites, articles 2.1 and 2.2 seem to be identical.

Answer: [An addendum will be issued to answer this question.](#)

Question 2: On the drawings SPF 1/ SPF 2 wood quality is mentioned. However, the specifications only show #1 wood.

Answer: [An addendum will be issued to answer this question.](#)

Question 3: Could you specify the thickness of existing pavement to be removed as well as the thickness of the concrete slab to be demolished next to the building shown on drawing C03?

Answer: [The Contractor must consider that the thickness of existing pavement to be removed is 75 mm and that the thickness of the concrete slab to be demolished next to the building shown on drawing C03 is 1200 mm.](#)

Question 4: Would it be acceptable to finish the bottom of the beam horizontally instead of triangularly as shown on sections 35, 36, 38 et 39 of drawing 013?

Answer: [The triangular form is required.](#)

Question 5: Would it be acceptable to place a construction joint on sections 35, 36, 38 and 39 of drawing (red line)?

Answer: [The construction joint is not acceptable.](#)

Question 6: Considering the geometrical constraints and the limited space between the MG-20 backfill and the slab (section 27 of drawing 012), is the lost formwork under the slab acceptable?

Answer: [The “lost” formwork under the slab is acceptable.](#)

**THE BID CLOSING DATE REMAINS THE SAME.**

**ALL OTHER TERMS AND CONDITIONS REMAIN UNCHANGED.**

END OF SECTION.

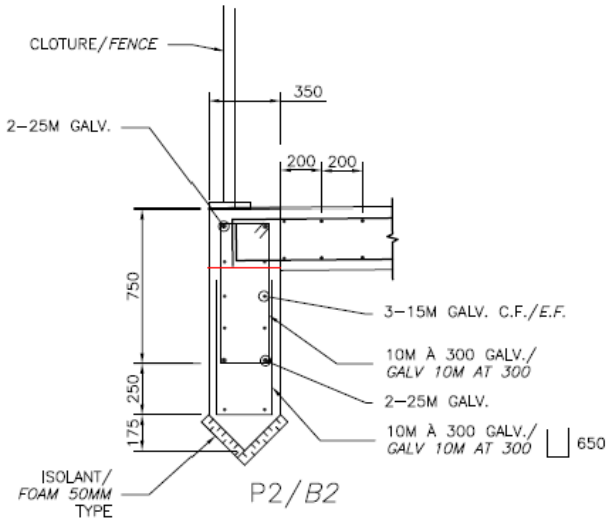

COUPE SECTION 35  
13|13

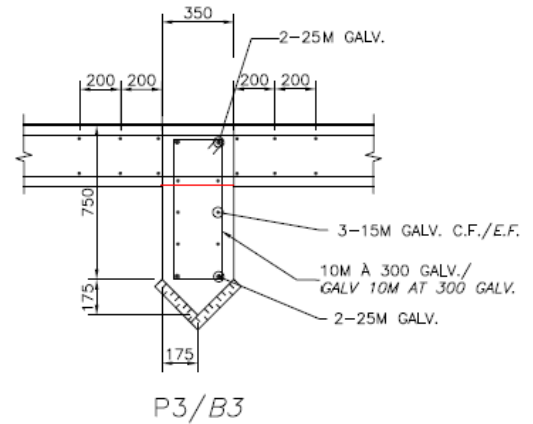

COUPE SECTION 36  
13|13

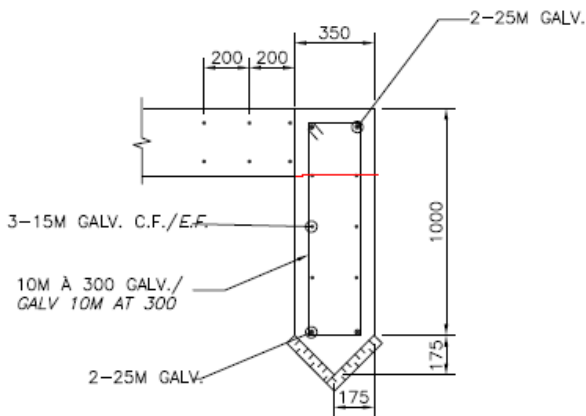

P2-1/B2-1  
 COUPE SECTION 38  
13|13

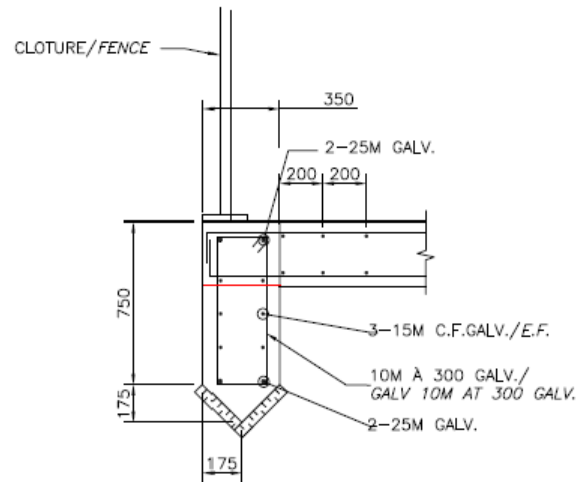

P1/B1 P1-1/B1-1  
 COUPE SECTION 39  
13|13