



Addendum / Addenda

No./N^o
1

Project Description / Description de projet U-72 cabine confort et facilité de recherche environnementale - La gestion de la construction		
Solicitation No./ No de sollicitation 16-22023	Project No./N ^o de projet U-72 5127	W.O. No./N ^o d'ordre de travail
Departmental Representative / représentant ministériel Maurice Richard		Date 2016-06-22
<p>Notice: This addendum shall form part of the tender documents and all conditions shall apply and be read in conjunction with the original plans and specifications.</p>		<p>Nota: Cet addenda fait partie intégrale des dossiers d'appel d'offres; toutes les conditions énoncées doivent être lues et appliquées en conjonction avec les plans et les devis originaux.</p>

DESCRIPTION

Ce document est émis pour répondre aux demandes d'information et/ou des éclaircissements reçus des soumissionnaires.

1. Modifications:

- 1.1. Cette demande de proposition est une entente similaire a un gestionnaire de construction a risque, le gestionnaire assumeras toutes les obligations et prendras a charge les responsabilité durant de la phase de construction semblables à un entrepreneur général. Une fois que le design est élaborées et mises au point. Le CNRC se réserve le droit d'entrer en agrément ou non avec un prix maximale garantie .
- 1.2. La date prévue des trois packages prêt pour l'appel d'offres est fin Juillet 2016. Le service de gestion de la construction pour la phase de conception n'est pas nécessaire et est exclu du contrat.
- 1.3. Les soumissionnaires sont tenus d'obtenir la DDP et addendum(s) à partir du site Web buyandsell.gc.ca uniquement. Le CNRC ne sera pas tenue responsable de toute erreur ou omission si les renseignements sont obtenus d'autres sources.
- 1.4. Les principaux membres du personnel de l'entrepreneur comprend au minimum : le gestionnaire de projet, l'estimateur des coûts , spécialiste de contrôle, surintendant, et officier de la sécurité du site. Bien que les personnes détenant des rôles multiples sont autorisées, une considérations complète sera accordée si ces postes sont comblés par des personnes différentes.

- 1.5. Le projet devrait être achevée substantiellement en 40 semaines, et à être entièrement achevé en 44 semaines. Le début du projet est en attente pour l'obtention de l'agrément de la Commission de la capitale nationale (CCN) et AAIMCO (Administration de l'aéroport international Macdonald-Cartier).
- 1.6. L'estimation de construction de classe C , compris les imprévus est de \$3,810,000.
- 1.7. Base de paiement est expliquée dans l'annexe G. remplacer "annexe (*)- Base de paiement " par " Annexe G - Base de paiement ", par l'intermédiaire de la DP
- 1.8. Dans le CS05-exigence de sécurité, ajouter "les entrepreneurs effectuant les travaux dans le bâtiment U61 doit avoir l'autorisation secret ou, encore, d'être escorté par un commissaire. Le CNRC offrira un commissaire pour le bâtiment U61 selon le besoin."
- 1.9. En vertu de CS08 CARACTÉRISTIQUES DU PROJET, élément #1, l'état de documents de conception, supprimer "compte tenu de l'annexe, le travail doit débuter avant l'achèvement de documents" et remplacer par " en considérant le calendrier, les tâches doivent commencer après l'achèvement des documents pour chaque packages ".
- 1.10. En vertu de CS08 CARACTÉRISTIQUES DU PROJET, élément n° 2. L'exécution de l'ouvrage, ajouter à la fin du premier paragraphe " la date de début du contrat et du début des travaux est seulement après l'obtention de l'approbation de la CCN et AAIMCO "
- 1.11. En vertu de EPEP1-RENSEIGNEMENTS GÉNÉRAUX, élément #1.1.5-documents à être inclus dans la deuxième enveloppe, supprimer "b. Tableau des prix de l'Appendice H - Base de paiement".
- 1.12. En vertu de EPEP1- RENSEIGNEMENTS GÉNÉRAUX, élément #1.2.1-Proposition technique, supprimer "les modèles de rapports de projet. Se reporter au EPEP 2.1" et remplacer par "échantillon de deux rapports de projet. Se reporter au EPEP 2.1.2"
- 1.13. Dans la version française sous EPEP 1 RENSEIGNEMENTS GENERAUX supprimer "6.1 PRESENTATION DES PROPOSITIONS" et remplacer par "1.1 PRESENTATION DES PROPOSITIONS."
- 1.14. L'annexe C, GC 48 Détermination du coût- Tableau des prix unitaires, élément # 48.1, supprimer "énoncée dans la colonne 3 du tableau des prix unitaires par le prix de cette unité indiquée dans la colonne 5 du tableau des prix unitaires".
- 1.15. Annexe F, Section 2 Description des services et des travaux requis, tous les services liés aux services de temps (SR4) Coût des services (SR5) et gestion des risques (SR6) seront remboursés selon " Base de paiement ", point 2.A- Tarif fixe.
- 1.16. RS 14 MISE EN SERVICE, supprimer le premier paragraphe et le remplacer par "Embaucher un spécialiste de mise en service qui sera l'Autorité de mise en service pour le projet, de diriger un processus de mise en service, ou programme d'activités, pour tout le travail qu'il est raisonnable et pratique. Ce spécialiste sera d'aider à documenter les résultats d'essai, en témoignant. Le coût de la mise en service seront remboursés selon " Base de paiement " Point 3-coût de construction". Voir l'annexe G, point No. 3.4 . Le coût d'ingénieur sur le terrain si nécessaire seront remboursés en vertu de l'article-3 coût de construction.

- 1.17. Dans la version française de l'annexe F, SR 5 SERVICES D'ÉTABLISSEMENT DES COÛTS, Supprimer "à l'achèvement de l'avant-projet (documents d'appel d'offres à 66 %, 99 % et 100 %)" et remplacer par "à l'achèvement de l'avant-projet (documents d'appel d'offres 100 %)"
- 1.18. RS 18,6 TAXES, PERMIS ET CERTIFICATS, ajoutez
" un permis de construire n'est pas requis pour la construction. Le CNRC est à la recherche des approbations de la part de L' Administration de l'Aéroport international MacDonald-Cartier d'Ottawa(AAIMCO) et de la Commission de la capitale nationale (CCN). La portée du projet, le coût et le temps sont sujettes à changement en attente par examen par la CCN et AAIMCO."
- 1.19. L'annexe G- Base de paiement, point 3.a, supprimer "GC5- Modalités de paiement " et remplacer par " Annexe B- Modalités de paiement".

1. Notes:

- 2.1 Les deux listes des participants des conférences sont jointes .
- 2.2 Une version révisée de l'appendice " A " - Formulaire de proposition de prix en MS. Les formats Word et PDF est jointe.
- 2.3 Cet addenda comprend les 50 % de dessins publiés pour examen en procédant comme suit :
- Geo-tech Report
 - Civil Drawings issued for 50% review by Ainely dated 15 June 2016
A100, A101, A102, A103
 - Architectural Drawings issued for 50% review by KWC dated 15 June 2016
A00, A101, A102, A103, A200, A201, A300
 - M&E Drawings issued for 50% review by Goodkey Weedmark Consulting Eng. dated 15 June 2016
M1, M2, M3, M4, M5, E1, E2, E3 by

2. Questions et réponses :

Q1- Nous voulons simplement confirmer qu'un addendum est émis pour le rapport des sols tel que discuté à la réunion du site.

R1- La géo-tech report est joint pour référence.

Q2- Dans le DP, EPEP 1, élément # 5:

- a. ENVELOPPE 2 – PROPOSITION FINANCIÈRE
- b. numéro de l'invitation
- c. nom du soumissionnaire.

Documents à inclure dans l'enveloppe 2 :

- a. Formulaire de soumission et d'acceptation (Annexe A)
- b. Tableau des prix de l'Annexe H – Base de paiement
- c. Garantie de la soumission

Quand nous allons l'annexe H, il est nommé: Instructions relatives à l'obtention des attestations de sécurité obligatoires. Nous ne pouvons pas trouver le tableau des prix de l'appendice H. Pourriez-vous s'il vous plaît clarifier ou fournir?

R2- Il y a une erreur typographique. Voir additif 1, élément # 1.7.

Q3- EPEP 1.2.1 : dans les documents listés qui ne comptent pas dans les 30 pages de rédactions, « modèles de rapports du projet » est là. Ils réfèrent à EPEP 2.1 (qui n'en parle pas). On parle de ses rapports à SR5 et SR9, mais il n'est pas demandé de les mettre dans la soumission, mais plutôt de les présenter une fois le projet en marche. Qu'en est-il vraiment?

R3- Voir additif 1, élément # 1.11.

Q4- Dans l'annexe C, articles # CG46 - CG50 : on mentionne encore un « tableaux des prix unitaires » que je n'ai pas trouvé? CG48 parle même de la colonne 5 du tableau des prix unitaires...

R4- Le seul tableau des prix unitaires indiqués pour le personnel, à la page 2 de l'annexe A.

Q5- SR4 : « embaucher un ordonnancier ». Est-ce que ça peut être fait à l'interne?

R5- Le temps, coûts et risques Les services peuvent être fait dans la maison aussi longtemps que le personnel sont compétents pour fournir les services qui sont énumérés sous SR4, SR5 et SR6.

Q6- Est-il possible d'avoir la version électronique (MS Word)du document de l'annexe "A" - Formulaire de proposition de prix?

R6- Voir additif 1 point 2.2.

Q7- Je crois que l'intention est d'engager un directeur de la construction comme un agent du CNRC, mais la forme du contrat est incertaine. Il y a un certain nombre de termes et de références qui sont généralement associés à des contrats forfaitaires prévus qui sont hors de l'alignement avec l'intention. Je voudrais recommander le CNRC utilise la norme industrielle « CCDC 5A – 2010 » du contrat de gestion et des services qui est convenablement structuré pour un tel engagement.

R7- Voir additif 1. L'article #1.1 pour le formulaire de contrat. L'entrepreneur peut utiliser les formulaires d'embaucher les CCDC sous-traitants.

Q8- Le cautionnement (bond) n'est généralement pas fourni par le CM en vertu d'un engagement d'Agence, car il est seulement leurs frais et tout travail direct (très minime) qui pourrait être lié. Par conséquent, il est inapproprié d'inclure la liaison dans les propositions.

R8- Voir additif 1. L'article #1.1 pour le formulaire de contrat.

Q9- L'assurance de « Builders Risk » peut être assurée par les promoteurs, une fois que la portée du travail est connu (par exemple une offre complète avec un budget de classe «A») et il est considéré comme un coût direct pour le projet. Il est inapproprié d'inclure cette assurance dans le cadre de la taxe d'examen par le promoteur, en particulier compte tenu la conception limitée et le coût des informations disponibles dans la DP. Cette exigence devrait être retiré de l'appel d'offres de CM et de rester une exigence de prix et de sécurité dans le cadre des services budgétaires et de gestion des marchés publics.

R9- Voir additif 1. L'article #1.1 pour le formulaire de contrat. Voir l'annexe G- Base de paiement, élément#5 admissible de décaissement, de cautionnement et d'assurance section pour référence.

Q10- L'annexe G # 2.b- Pour les honoraires proportionnels de construction (point B des montants de la soumission), au point b de la Base de paiement, on dit qu'ils sont la somme de :

% de profit/majoration, applicable sur les coûts de constructions SAUF les frais reliés au bureau de chantier

+

Les frais de bureau de chantier

+

Tous les autres coûts non spécifiés ailleurs.

Mais ce montant dans la soumission est représenté par un % appliqué sur un montant que nous devons déterminer. Est-ce qu'on met donc un % sur le 3810000\$ qui va nous assurer de couvrir les profits ET les frais de bureau? Je ne comprends pas la logique de mettre ce montant en % si on veut y inclure le coût du bureau de chantier. Il me semble que ce serait plus simple si le bureau de chantier était inclus dans le point A, honoraires fixes.

R10- L'intention est de garder le coût de construction distinct de l'entrepreneur les coûts d'exploitation. Cette clause demeure tel quel.

Fin de l'Addenda no 1

ANNEXE A

FORMULAIRE DE LA PROPOSITION DE PRIX (5 pages)

SA01 IDENTIFICATION

- Description : Services de gestion de la construction
Édifice U72, campus Uplands
Chemin Research, Ottawa (Ontario)
- Numéro d'invitation : RFP16-22023
- Nom du projet : IRCEC – Édifice U72

SA02 NOM COMMERCIAL ET ADRESSE DU SOUMISSIONNAIRE

- Nom : _____
- Adresse : _____
- Téléphone : _____ Télécopieur : _____ NEA : _____

SA03 OFFRE

- Le soumissionnaire offre au CNRC de terminer les travaux du projet susmentionné, conformément aux documents d'invitation à soumissionner pour le **MONTANT DE PROPOSITION TOTAL** de

_____ \$, **excluant** toutes les taxes applicables.
(exprimé en chiffres seulement)

Le **MONTANT DE PROPOSITION TOTAL** représente la somme des éléments a), b), c), d) et e) ci-dessous (taxes applicables en sus) :

a) Administration du projet et services requis, y compris les services de coordination de la construction. Honoraires mensuels (point 2. a) de l'Annexe G - Base de paiement) de _____ \$ x 44 semaines = _____ \$

b) Honoraires de construction proportionnels (point 2.b) de l'Annexe B - Base de paiement) de _____ % x **3 810 000,00** = _____ \$

c) Coûts de construction estimatifs : **3 810 000,00 \$**

d) Caution et assurance (se reporter au point 5) de l'Annexe G – Base de paiement) : _____ \$

e) Tarifs journaliers fermes * (y compris les coûts salariaux, les frais fixes et les bénéfices) pour le personnel supplémentaire requis pour effectuer les heures normales de travail et les heures supplémentaires (point 2. c) de l'Annexe G – Base de paiement). Voir le tableau ci-dessous.

Catégorie de personnel Heures normales de travail	Nombre de jours (X)	Tarif journalier ferme (Y)	Tarif journalier ferme Prix calculé (X x Y)
Directeur des travaux	20		
Agent de santé et sécurité	20		
Total des prix calculés			

Catégorie de personnel En dehors des heures normales de travail	Nombre de jours (X)	Tarif journalier ferme pour les heures supplémentaires (Y)	Tarif journalier ferme Prix calculé (X x Y)
Directeur des travaux	3		
Agent de santé et sécurité	3		
Total des prix calculés pour les heures supplémentaires			

* Les nombres de jours et les catégories de personnel présentés à l'élément e) ci-dessus sont fournies aux fins d'évaluation seulement et ne doivent pas être interprétés par le soumissionnaire comme un engagement du CNRC à faire appel aux services de quelque employé que ce soit pour quelque nombre de jours que ce soit.

2. Toute erreur d'addition ou de multiplication des montants des éléments 1. a), b), c), d) et e) du point SA03 sera corrigée par le CNRC afin d'obtenir le montant total de la proposition.

3. Le CNRC peut rejeter la soumission si les prix soumis ne reflètent pas raisonnablement les coûts associés à l'exécution de la partie des travaux associée à ce prix.

4. L'entrepreneur maintiendra les honoraires mensuels fixes malgré tout retard d'une phase qui pourrait prolonger de trois mois maximum la durée totale de la phase. Les honoraires mensuels fixes doivent faire l'objet de négociations pour tout retard d'une phase de plus de trois mois.

SA04 COÛT DE CONSTRUCTION DES TRAVAUX

1. Les frais de main-d'œuvre, d'outillage et de matériaux visés à l'élément 1. b) du point SA03 sont limités aux catégories de dépenses suivantes :

a) les paiements versés aux sous-traitants et aux fournisseurs;

b) les traitements, les salaires et les primes versés aux employés de l'entrepreneur, à la condition que ces employés soient effectivement affectés de manière appropriée aux travaux prévus au contrat;

c) les cotisations exigibles en vertu des lois se rapportant à l'indemnisation des accidents du travail, l'assurance-emploi, le régime de retraite ou les congés rémunérés, les régimes d'assurance-maladie ou d'assurance des provinces, les examens environnementaux et les frais de perception de la taxe sur les produits et services ou de la taxe de vente harmonisée;

d) les paiements relatifs aux matériaux nécessaires et intégrés aux travaux, ou nécessaires à l'exécution du contrat et utilisés à cette fin;

e) les paiements relatifs à la préparation, à la livraison, à la manutention, au montage, à l'installation, à l'inspection et à la protection du projet et des matériaux nécessaires à l'exécution du contrat et utilisés à cette fin;

f) payer les honoraires et les impositions, et obtenir tous les permis exigés par les autorités compétentes. Fournir aux autorités les plans, les demandes et les renseignements requis pour obtenir les permis et les certificats d'acceptation. Présenter des certificats d'inspection et d'achèvement comme preuve que le travail est conforme aux exigences de l'autorité compétente. Seuls les coûts réels des honoraires ou des impositions seront remboursés, conformément au point 4, Débours permis, de l'Annexe B – Base de paiement. Tous les travaux liés à l'obtention des permis ou des certificats doivent être compris dans les honoraires mensuels fixes se rapportant à l'administration du projet et aux services requis;

h) tout autre paiement fait par l'entrepreneur avec l'approbation du CNRC qui est nécessaire à l'exécution du contrat, conformément aux documents contractuels.

SA05 PÉRIODE DE VALIDITÉ DES PROPOSITIONS

1. La proposition ne peut être retirée pour une période de **soixante (60) jours** suivant la date de clôture de l'invitation.

SA06 DOCUMENTS DU CONTRAT (DC)

1. Les documents suivants constituent le contrat :

- a) la page « Contrat » une fois signée par le CNRC;
- b) le Formulaire de soumission et d'acceptation dûment rempli ainsi que toutes les annexes en pièce jointe;
- c) la demande de propositions ainsi que tous les appendices, toutes les annexes et toutes les modifications s'y trouvant;
- d) le Cadre de référence et la Base de paiement;
- e) les clauses et conditions générales :
 - CG1 Dispositions générales – Services de construction
 - CG2 Administration du contrat
 - CG3 Exécution et contrôle des travaux
 - CG4 Mesures de protection
 - CG5 Modalités de paiement
 - CG6 Retards et modifications des travaux
 - CG7 Défaut, suspension ou résiliation du contrat
 - CG8 Règlement des différends
 - CG9 Garantie contractuelle
 - CG10 Assurances
 - Coûts admissibles pour les modifications de contrat sous CG6.4.1.
 - Conditions supplémentaires
- f) toute modification émise ou toute révision de soumission recevable, reçue avant l'heure et la date déterminée pour la clôture de l'invitation;
- g) toute modification incorporée d'un commun accord entre le CNRC et l'entrepreneur avant l'acceptation de la soumission;
- h) toute modification aux documents du contrat qui est apportée conformément aux conditions générales; et
- i) la proposition technique de l'entrepreneur.

2. La langue des documents du contrat est celle du Formulaire de soumission et d'acceptation présenté.

SA07 ACCEPTATION ET CONTRAT

1. À l'acceptation de la proposition de l'entrepreneur par le CNRC, un contrat exécutoire est établi entre le CNRC et l'entrepreneur. Les documents contractuels constituant le contrat correspondront aux documents décrits au DOCUMENTS CONTRACTUELS.

SA08 DURÉE DES TRAVAUX

1. L'ensemble des travaux doit être réalisé en quarante-quatre (**44**) semaines.

SA09 GARANTIE DE SOUMISSION

1. Le soumissionnaire joint à sa soumission une garantie de soumission conformément à l'IG16 EXIGENCES RELATIVES À LA GARANTIE DE SOUMISSION.

SA11 SIGNATURE

Nom et titre de la personne autorisée à signer au nom du soumissionnaire (caractères d'imprimerie)

Signature

Date



December 2015

REPORT ON

Geotechnical Investigation Proposed Research Building National Research Council Uplands Campus 1920 Research Road Ottawa, Ontario

Submitted to:
Dr. Paul Lebbin
National Research Council Canada
1200 Montreal Road
Ottawa, Ontario
K1A 0R6

REPORT



A world of
capabilities
delivered locally

Report Number: 1542724

Distribution:

2 copies - National Research Council Canada
1 copy - Golder Associates Ltd.





Table of Contents

1.0 INTRODUCTION.....	1
2.0 DESCRIPTION OF PROJECT AND SITE	2
3.0 PROCEDURE	3
4.0 SUBSURFACE CONDITIONS.....	4
5.0 DISCUSSION.....	5
5.1 General.....	5
5.2 Site Grading.....	5
5.3 Excavations	5
5.4 Seismic Considerations	6
5.4.1 Liquefaction Assessment	6
5.4.2 Site Classification for Seismic Site Response.....	7
5.5 Foundations.....	7
5.5.1 Shallow Foundations.....	7
5.5.2 Seismic Liquefaction Mitigation – Rapid Impact Compaction (RIC)	8
5.6 Frost Protection	9
5.7 Floor Slabs	9
5.7.1 Slab on Grade.....	9
5.7.2 Basement and Tunnel Floor Slabs.....	9
5.8 Foundation Wall Backfill and Lateral Earth Pressure.....	10
5.9 Site Servicing.....	11
5.10 Pavement Design	11
5.11 Corrosion and Cement Type.....	12
6.0 ADDITIONAL CONSIDERATIONS.....	13
7.0 CLOSURE.....	14

Important Information and Limitations of This Report



FIGURES

Figure 1 – Key Plan

Figure 2 – Site Plan

Figure 3 – Results of Grain Size Distribution Testing – Silty Sand

APPENDICES

APPENDIX A

List of Abbreviations and Symbols

Record of Borehole Sheets

APPENDIX B

Results of Basic Chemical Analysis

EXOVA Laboratories Report No. 1522272

DRAFT



1.0 INTRODUCTION

This report presents the results of a geotechnical investigation carried out for a proposed research building to be located at 1920 Research Road on the National Research Council Canada (NRC) Uplands Campus in Ottawa, Ontario.

The purpose of this geotechnical investigation was to assess the general subsurface conditions in the area of the proposed building by means of four boreholes and laboratory testing. Based on an interpretation of the factual information obtained, a general description of the subsurface conditions is presented. These interpreted subsurface conditions and available project details were used to prepare engineering guidelines on the geotechnical design aspects of the project, including construction considerations which could influence design decisions.

The reader is referred to the "Important Information and Limitations of This Report" which follows the text but forms an integral part of this document.

DRAFT



2.0 DESCRIPTION OF PROJECT AND SITE

Plans are being prepared for the construction of a research building to be located at 1920 Research Road on the NRC Uplands Campus in Ottawa, Ontario. The approximate location of the site is shown on the attached Key Plan (Figure 1).

The following is known about the project and site:

- The proposed research building will be located at the southwest corner of the property between the existing U61 and R.C.M.P Hangar buildings on Research Road.
- The building will be 30.5 metres wide and 42.7 metres long in plan area.
- The building will be about 9 metres in height and will mostly be of slab-on-grade construction (i.e., no basement level). It is understood that two areas of the building will have below grade construction, including a 3 metre deep tunnel connection to the U61 building and a 1.2 metre deep pit to be used as a laboratory space.
- The existing site is undeveloped and vegetated with grass. The ground surface is relatively flat to gently sloping, with ground surface elevations ranging from about 113 to 114 metres.

Golder Associates has carried out several previous geotechnical investigations on the NRC Uplands Campus and the Ottawa International Airport lands. Based on the results of those previous investigations, as well as published geological mapping, the subsurface conditions at this site are expected to consist of a thick deposit of sand. The underlying bedrock is indicated to be at about 15 to 25 metres depth.



3.0 PROCEDURE

The fieldwork for this investigation was carried out on October 30, 2015. At that time, four boreholes (numbered 15-1 to 15-4, inclusive) were advanced at the locations shown on the attached Site Plan (Figure 2).

The boreholes were advanced to depths ranging from about 5.3 to 6.1 metres below the existing ground surface using a track-mounted hollow-stem auger drill rig supplied and operated by George Downing Estate Drilling of Grenville-sur-la-Rouge, Quebec.

Standard penetration tests were carried out within the boreholes at regular intervals of depth and samples of the soils encountered were recovered using split spoon sampling equipment. Upon reaching the target sampling depth in borehole 15-3 (about 6 metres), a dynamic cone penetration test (DCPT) was conducted to a final depth of about 25 metres below the existing ground surface.

A standpipe piezometer was sealed into borehole 15-4 to allow for subsequent measurement of the groundwater level. The groundwater level was measured in the standpipe on November 5, 2015.

The fieldwork was supervised by an experienced technician from our staff who located the boreholes, directed the drilling and in situ testing operations, logged the boreholes and samples, and took custody of the samples retrieved. On completion of the drilling operations, samples of the soils obtained from the boreholes were transported to our laboratory for examination by the project engineer and for laboratory grain size distribution testing.

One sample of soil from borehole 15-1 was submitted to EXOVA Laboratories for chemical analysis related to potential corrosion of buried steel elements and potential sulphate attack on buried concrete elements.

The boreholes were selected, marked in the field, and subsequently surveyed by Golder Associates personnel. The positions and ground surface elevations at the borehole locations were determined using a Trimble R8 GPS survey unit. The Geodetic reference system used for the survey is the North American datum of 1983 (NAD83). The borehole coordinates are based on the Universal Transverse Mercator (UTM Zone 18) coordinate system. The elevations are referenced to Geodetic datum (CGVD28).



4.0 SUBSURFACE CONDITIONS

The subsurface conditions encountered in the boreholes are shown on the Record of Borehole Sheets provided in Appendix A. The results of the basic chemical analysis are provided in Appendix B.

In general, the subsurface conditions consist of about 120 to 300 millimetres of topsoil overlying a thick deposit of sand that contains discontinuous interbedded silty clay layers. The sand deposit is generally layered and is composed of silty sand to sand with varying amounts of gravel, cobbles and boulders. The results of grain size distribution testing carried out two samples of silty sand are provided on Figure 3.

At boreholes 15-1 and 15-2, the sand deposit contains significant amounts of gravel, cobbles and boulders below about 3.7 metres depth. Practical refusal to augering was encountered within these two boreholes at about 6.1 and 5.3 metres depth, respectively. Based on published geological mapping and the depth of the DCPT completed at borehole 15-3, it is considered likely that these auger refusals represent boulders with the sand deposit rather than the bedrock surface.

In all of the boreholes, the sand deposit contains discontinuous clayey silt seams and silty clay layers.

Standard penetration tests carried out within the sand deposit, excluding the silty clay layers, gave 'N' values ranging from 2 to greater than 50 blows per 0.3 metres of penetration, indicating a very loose to very dense state of packing. The higher 'N' values (greater than 50 blows per 0.3 metres of penetration) may reflect the presence of cobbles or boulders within the sand deposit, rather than the state of packing of the soil matrix. Standard penetration tests carried out within the silty clay layers gave 'N' values ranging from 4 to 9 blows per 0.3 metres of penetration, indicating a stiff to very stiff consistency.

The groundwater level was measured in the standpipe sealed in borehole 15-4 on November 5, 2015. At that time, the groundwater level was measured at a depth of about 3.9 metres below the existing ground surface (i.e., about elevation 109.4 metres). Groundwater levels are expected to fluctuate seasonally. Higher groundwater levels are expected during wet periods of the year, such as spring.

One sample of soil from borehole 15-1 was submitted to EXOVA Laboratories for chemical analysis related to potential corrosion of buried steel elements and potential sulphate attack on buried concrete elements. The results of this testing are provided in Appendix B and are summarized in the table below.

Borehole/Sample Number	Sample Depth (m)	Chloride (%)	SO ₄ (%)	pH	Resistivity (ohm-cm)
15-1 / Sa 3	1.5 – 2.1	0.003	<0.01	8.2	6,250



5.0 DISCUSSION

5.1 General

This section of the report provides engineering guidelines on the geotechnical design aspects of the project based on our interpretation of the available information described herein and project requirements.

Reference should be made to the “Important Information and Limitations of this Report” which follows the text of this report but forms an integral part of this document.

The foundation engineering guidelines presented in this section have been developed in a manner consistent with the procedures outlined in Part 4 of the 2010 National Building Code of Canada (NBCC) for Limit States Design.

5.2 Site Grading

In general, the subsurface conditions on this site consist of about 120 to 300 millimetres of topsoil overlying a thick deposit of sand that contains discontinuous interbedded silty clay layers. Based on the results of this investigation, there is no practical limit on the amount of grade raise fill that can be placed on this site (from the perspective of the compressibility of the underlying soil).

As a more general guideline regarding the site grading, the preparation for filling of the site should include stripping the topsoil within the footprint of the proposed structure. The topsoil should also be removed from beneath pavement areas (if planned). The topsoil should be stockpiled separately for re-use in landscaping applications only.

5.3 Excavations

No unusual problems are anticipated in excavating the overburden materials using conventional hydraulic excavating equipment, recognizing that large cobbles and boulders should be expected within the sand deposit. Boulders larger than 0.3 metres in size should be removed from the walls of the excavations for worker safety.

Provided that the groundwater level is not encountered during excavation (which is expected to be the case), the Occupational Health and Safety Act (OHSA) of Ontario indicates that side slopes in the overburden could be sloped at a minimum of 1 horizontal to 1 vertical (i.e., Type 3 soils). Steeper side slopes would require shoring to meet the requirements of the OHSA.

The groundwater level was measured in the standpipe sealed in borehole 15-4 on November 5, 2015. At that time, the groundwater level was measured at a depth of about 3.9 metres below the existing ground surface (i.e., about elevation 109.4 metres). For construction of the basement areas, it is anticipated that the excavation would be no deeper than about 3 metres depth, and therefore above the groundwater level. As such, groundwater inflow into the excavations is anticipated to be minimal. Water that accumulates in the bottom of the excavations (e.g., from perched groundwater, surface water, or precipitation) can be handled by pumping from well filtered sumps established in the floor of the excavations. Provided that excavations do not extend deeper than the groundwater level, it is not expected that the pumping volumes will be in excess of 50,000 litres per day; therefore, the requirement for a Permit-To-Take-Water (PTTW) is not anticipated. If construction occurs during or following a period of sustained rain or snowmelt (e.g., during spring), a higher groundwater level than was measured during the geotechnical investigation should be expected.



If deeper excavations are planned, groundwater inflow through the sand deposit could be significant, and has the potential to disturb the subgrade and destabilize excavation side-slopes. In that case, an active dewatering program would likely be needed in order to lower the groundwater level in advance of excavation. The volume of water to be pumped would also likely exceed 50,000 litres per day, and therefore a PTTW would be required. Further assistance with respect to excavation dewatering and preparing a PTTW can be provided, if required.

5.4 Seismic Considerations

The site is located in an area where there exists a history of earthquake activity. The potential for seismic liquefaction of the overburden therefore needs to be assessed. A seismic Site Class also needs to be assigned, to be used by the structural designer.

5.4.1 Liquefaction Assessment

Seismic liquefaction occurs when earthquake vibrations cause an increase in pore water pressures within the soil. The presence of excess pore water pressures reduces the effective stress between the soil particles, and the soil's frictional resistance to shearing. This phenomenon, which leads to a temporary reduction in the shear strength of the soil, may cause:

- Large lateral movements of even gently sloping ground, referred to as "lateral spreading";
- Reduced shear resistance (i.e., bearing capacity) of soils which support foundations, as well as reduced resistance to sliding; and,
- Reduced shaft resistance for deep foundations as well as reduced resistance to lateral loading.

In addition, 'seismic settlements' may occur once the vibrations and shear stresses have ceased. Seismic settlement is the process whereby the soils stabilize into a denser arrangement after an earthquake, causing potentially large surface settlements.

The following conditions are more prone to experiencing seismic liquefaction:

- Coarse grained soils (i.e., more probable for sands than for silts);
- Soils having a loose state of packing; and,
- Soils located below the groundwater level.

An assessment of the liquefaction potential of the sand deposit was carried out using the Seed and Idriss (1971) simplified procedure based on SPT N_{60} -values from the boreholes. The SPT N-values reported on the borehole records were corrected for overburden stress, rod length during sampling, and hammer energy efficiencies. The assessment is based on an earthquake with a magnitude of 6.0 and a peak ground acceleration of 0.37g (Ottawa area specified design values for a Site Class D site).

The results of this assessment suggest that a looser zone within the sand deposit, about 0.6 to 0.7 metres in thickness at about elevation 109 metres, is susceptible to liquefaction under the west side of the building (i.e., boreholes 15-3 and 15-4). Conversely, the sand deposit at the east side of the building (boreholes 15-1 and 15-2) would not be classified as liquefiable. The assessment assumes that the grade raise on the site would be negligible (a conservative assumption).



The anticipated total and differential settlement of the liquefiable native sand under the analyzed earthquake event could be up to about 25 and 15 millimetres, respectively. The amount of settlement is highly dependant on the earthquake event, the thickness of the deposit and its liquefaction potential, and therefore settlements could be highly variable.

The seismic settlements would be in addition to the anticipated settlements under static loading, which are discussed in Section 5.5.1.

If the foundations of the proposed building are founded above or within these materials (which will be the case if shallow foundations are used), then the structure should be designed to accept this differential settlement without experiencing collapse, which should be feasible. It should be noted that guarding against collapse (i.e., allowing for 'safe exit') is considered to be the design objective for earthquake conditions (recognizing that the 'design' earthquake has a return period of 2,475 years), although the structure may be damaged by the earthquake and rendered unserviceable.

Alternatively, the proposed building could be founded on deep foundations, or the liquefiable soils could be improved (i.e., densified) to reduce their liquefaction potential. Further discussion regarding soil improvement can be provided if the seismic settlements can not be accommodated.

5.4.2 Site Classification for Seismic Site Response

The seismic design provisions of the 2010 NBCC depend, in part, on the shear wave velocity of the upper 30 metres of soil and/or rock below founding level. The NBCC permits the Site Class to be specified based solely on the stratigraphy and in situ testing data (i.e., standard penetration test results), rather than from direct measurements of the shear wave velocity.

The NBCC requires a Site Class F designation for sites with liquefiable soils, which would require that a site-specific seismic response evaluation be carried out for the design of this building. However, the code allows the use of a "non-liquefied" Site Class for structures having a fundamental period of vibration less than or equal to 0.5 seconds. It is anticipated that this will be the case for the proposed building; however, this would need to be confirmed by the structural engineer. In that case, a non-liquefied Site Class D designation can be used for design (based on the standard penetration test 'N' values recorded in the boreholes). Due to the depth of bedrock at this site (deeper than 25 metres based on the DCPT results), it is not expected that site specific shear wave velocity testing (e.g., Multichannel Analysis of Surface Waves) would provide a more favourable Site Class and therefore is not recommended.

5.5 Foundations

The proposed building is underlain by a deposit of liquefiable sand (at depth), as discussed in Section 5.4.1. Provided that the seismic settlements can be accommodated (as anticipated), or mitigated using densification techniques (discussed in Section 5.5.2), the building can be designed using conventional shallow foundations. A discussion of this foundation type is given below. Additional discussion on alternative foundation types (e.g., deep foundations) can be provided, if requested.

5.5.1 Shallow Foundations

It is anticipated that most of the footings will bear on native silty sand or sand. In some areas, weathered silty clay may also be encountered at footing level.



The bearing resistance at Serviceability Limit States (SLS) for footings bearing on undisturbed native soil (sand or silty clay) may be taken as 150 kilopascals for footings up to 3 metres in width. The factored bearing resistance at Ultimate Limit States (ULS) may be taken as 250 kilopascals.

The post construction total and differential settlements of footings sized using the above SLS net bearing resistance value (for non-seismic loading conditions) should be less than about 25 and 15 millimetres, respectively, provided that the soil at or below founding level is not disturbed during construction. For the design earthquake event, these footings would experience seismic settlements, which are estimated to result in an additional 25 millimetres of differential settlement in the areas of boreholes 15-3 and 15-4 (west side of the building), as previously discussed in Section 5.4.1.

The factored ULS bearing resistance will potentially decrease following the design earthquake as a result of liquefaction of the underlying sand layer at depth. The magnitude of the strength decrease is dependent on the footing size and the depth to the liquefiable layer. For this site, various post-liquefaction ULS bearing resistance values (based on footing depths of 1.5 and 3.0 metres depth for the slab on grade and basement areas, respectively) are provided in the following table:

Footing Width (m)	Post-Liquefaction Factored ULS Bearing Resistance (kPa)	
	Footing Elevation = 111.5 m (1.5 m deep)	Footing Elevation = 110.0 m (3.0 m deep)
0.6	250	200
0.8	250	145
1.0	220	115
1.3	150	90
1.5	130	80
2.0	100	70

The values given above will change for different footing sizes and footing depths. Further guidance with respect to post-liquefaction bearing resistance can be provided, if requested.

5.5.2 Seismic Liquefaction Mitigation – Rapid Impact Compaction (RIC)

If the seismic settlements and/or post-liquefaction ULS bearing resistance given above cannot be accommodated, consideration can be given to carrying out a ground improvement program to mitigate the potential liquefaction. It is anticipated that the most cost-effective option for this project would be rapid impact compaction (RIC). With this method, dynamic energy is imparted to the ground by repeatedly dropping a 7.5 ton weight from a controlled height onto a patented foot. Compaction parameters are automatically controlled and monitored from the RIC's cab with an on-board data acquisition system.

If this method is employed, the RIC soil improvement should be carried out within the entire building footprint plus at least 3 metres laterally beyond the footprint. The influence depth of RIC would be typically about 5 metres to 7 metres below the ground surface based on the known site conditions. A performance



specification and verification testing program (i.e., post-RIC standard penetration testing) should be developed. For this site, it is anticipated that upon completion of the RIC program, the potential for liquefaction will be eliminated, and design can proceed assuming that seismic settlements will not occur. In addition, higher bearing resistance values could likely be provided. Further guidance with respect to RIC can be provided, if requested.

5.6 Frost Protection

Most of the soils at this site are considered to be frost susceptible. Therefore, all exterior foundation elements should be provided with a minimum of 1.5 metres of earth cover for frost protection purposes. Isolated, unheated footings adjacent to surfaces which are cleared of snow cover during winter months should be provided with a minimum of 1.8 metres of earth cover.

5.7 Floor Slabs

5.7.1 Slab on Grade

In preparation for construction of the slab on grade, the topsoil and all loose, wet, and disturbed material should be removed from within the building footprint. Provision should be made for at least 150 millimetres of Ontario Provincial Standard Specification (OPSS) Granular A to form the base for the slab on grade. Any bulk fill required to raise the grade to the underside of the Granular A should consist of OPSS Granular B Type II. The underslab fill should be placed in maximum 300 millimetre thick lifts and should be compacted to at least 95 percent of the material's standard Proctor maximum dry density using suitable vibratory compaction equipment.

If the native sands are not seismically improved during the site preparation, then the floor slab could settle, crack or heave during an earthquake event, since these native sands will liquefy and the floor slab will lose its support. However, this level of damage is considered to be consistent with the objectives of the seismic design in accordance with the National Building Code, and recognizing that the 'design' earthquake has a return period of about 2,475 years. The same applies for the basement floor slab as well.

5.7.2 Basement and Tunnel Floor Slabs

For the areas of the structure that will have a basement level, provision should be made for at least 200 millimetres of clear crushed stone to form the base of the basement floor slabs. The underslab fill should be placed in maximum 300 millimetre thick lifts and should be compacted to at least 95 percent of the material's standard Proctor maximum dry density using suitable vibratory compaction equipment.

To prevent hydrostatic pressure build up beneath the basement floor slabs, it is suggested that the granular base for the floor slabs be drained. This could be achieved by installing perforated pipes fully wrapped in a geotextile in the floor slab bedding that connects by gravity drainage to an exterior drainage system (storm sewer) or sump pit.

A geotextile should be provided between the clear stone underslab fill and the sandy subgrade soils, to avoid loss of fine soil particles from the subgrade soil into the voids in the clear stone and ultimately into the drainage system. In the extreme case, loss of fines into the clear stone could cause ground loss beneath the slab and plugging of the drainage system. Where a geotextile is required, it should consist of a Class II non-woven geotextile with a Filtration Opening Size (FOS) not exceeding about 100 microns, in accordance with OPSS 1860.



5.8 Foundation Wall Backfill and Lateral Earth Pressure

Most of the soils at this site are frost susceptible and should not be used as backfill against exterior, unheated, or well insulated foundation elements. To avoid problems with frost adhesion and heaving, foundation walls should be backfilled with non-frost susceptible sand or sand and gravel conforming to the requirements for OPSS Granular B Type I.

To avoid ground settlements around the foundations, which could affect site grading and drainage, all of the backfill materials should be placed in maximum 300 millimetre thick lifts and compacted to at least 95 percent of the material's standard Proctor maximum dry density.

Drainage of the wall backfill can be provided by means of a perforated pipe subdrain in a surround of 19 millimetre clear stone, fully wrapped in geotextile, which leads by gravity drainage to the exterior drainage system (storm sewer) or a sump pit.

Basement and tunnel walls made within open cut excavations, backfilled with granular material, and effectively drained as described above should be designed to resist lateral earth pressures calculated using a triangular distribution of the stress with a magnitude of:

$$\sigma_h(z) = K_o (\gamma z + q)$$

- Where:
- $\sigma_h(z)$ = Lateral earth pressure on the wall at depth z, kilopascals;
 - K_o = At-rest earth pressure coefficient, 0.5;
 - γ = Unit weight of retained soil, 20 kilonewtons per cubic metre;
 - z = Depth below top of wall, metres; and,
 - q = Uniform surcharge at ground surface behind the wall to account for traffic, equipment, or stockpiled soil (use 12 kilopascals as a minimum).

The lateral earth pressure equation given above is in an unfactored format and will need to be factored for Limit States Design purposes.

These lateral earth pressures would increase under seismic loading conditions. The earthquake-induced dynamic pressure distribution, which is to be added to the static earth pressure distribution, is a linear distribution with maximum pressure at the top of the wall and minimum pressure at its toe (i.e., an inverted triangular pressure distribution). The combined pressure distribution (static plus seismic) may be determined as follows:

$$\sigma_h(z) = K_o \gamma z + (K_{AE} - K_o) \gamma (H-z)$$

Where:

- K_{AE} = The seismic earth pressure coefficient, use 0.8 for a non-yielding wall, and,
- H = The total depth to the bottom of the foundation wall, metres.



5.9 Site Servicing

At least 150 millimetres of OPSS Granular A should be used as pipe bedding for sewer and water pipes. Where unavoidable disturbance to the subgrade surface occurs during construction, it may be necessary to place a sub-bedding layer consisting of 300 millimetres of compacted OPSS Granular B Type II beneath the Granular A. The bedding material should in all cases extend to the spring line of the pipe and should be compacted to at least 95 percent of the material's standard Proctor maximum dry density. The use of clear crushed stone as a bedding layer should not be permitted anywhere on this project since fine particles from the sandy backfill materials and native soils could potentially migrate into the voids in the clear crushed stone and cause loss of lateral pipe support.

Cover material, from the spring line of the pipe to at least 300 millimetres above the top of pipe, should consist of OPSS Granular A or Granular B Type I with a maximum particle size of 25 millimetres. The cover material should be compacted to at least 95 percent of the material's standard Proctor maximum dry density.

It should generally be possible to re-use the excavated inorganic soils as trench backfill. Where the trench will be covered with hard surfaced areas (e.g., pavements and sidewalks), the type of material placed in the frost zone (between subgrade level and 1.8 metres depth) should match the soil exposed on the trench walls for frost heave compatibility. Trench backfill should be placed in maximum 300 millimetre thick lifts and should be compacted to at least 95 percent of the material's standard Proctor maximum dry density using suitable vibratory compaction equipment.

5.10 Pavement Design

In preparation for pavement construction (if required), all topsoil and any unsuitable fill (i.e., fill containing organic matter) should be excavated from the pavement areas for predictable pavement performance.

Areas requiring grade raising to proposed subgrade level should be filled using acceptable (compactable and inorganic) earth borrow or OPSS Select Subgrade Material. Grade raise fill should be placed in maximum 300 millimetre thick lifts and should be compacted to at least 95 percent of the material's standard Proctor maximum dry density using suitable vibratory compaction equipment.

The surface of the subgrade or fill should be crowned to promote drainage of the pavement granular structure. Perforated pipe subdrains should be provided at subgrade level extending from the catch basins for a distance of at least 3 metres in four orthogonal directions, or longitudinally where parallel to a curb. Alternatively, the subdrains could outlet into a nearby drainage swale.

The pavement structure for access roadways and truck traffic areas should consist of:

Pavement Component	Thickness (mm)
Asphaltic Concrete	90
OPSS Granular A Base	150
OPSS Granular B Type II Subbase	450



The pavement structure for car parking areas should consist of:

Pavement Component	Thickness (mm)
Asphaltic Concrete	50
OPSS Granular A Base	150
OPSS Granular B Type II Subbase	300

The granular base and subbase materials should be uniformly compacted to at least 100 percent of the material's standard Proctor maximum dry density using suitable vibratory compaction equipment. The asphaltic concrete should be compacted in accordance with OPSS 310.

The composition of the asphaltic concrete pavement in car parking areas should be as follows:

- Superpave 12.5 Surface Course – 50 millimetres

The composition of the asphaltic concrete pavement in access roadways and truck traffic areas should be as follows:

- Superpave 12.5 Surface Course – 40 millimetres
- Superpave 19.0 Binder Course – 50 millimetres

The pavement design should be based on a Traffic Category of Level B. The asphalt cement used on this project should be made with PG 58-34 asphalt cement on all lifts.

The above pavement designs are based on the assumption that the pavement subgrade has been acceptably prepared (i.e., where the trench backfill and grade raise fill have been adequately compacted to the required densities and the subgrade surface not disturbed by construction operations or precipitation). Depending on the actual conditions of the pavement subgrade at the time of construction, it could be necessary to increase the thickness of the subbase and/or to place a woven geotextile beneath the granular materials.

5.11 Corrosion and Cement Type

One sample of soil from borehole 15-1 was submitted to EXOVA Laboratories for chemical analysis related to potential corrosion of buried steel elements and potential sulphate attack on buried concrete elements. The results of this testing are provided in Appendix B.

The results indicate that concrete made with Type GU Portland cement should be acceptable for substructures. The results also indicate a potential for corrosion of exposed ferrous metal.



6.0 ADDITIONAL CONSIDERATIONS

The soils at this site are sensitive to disturbance from ponded water, construction traffic, and frost.

All footing and subgrade areas should be inspected by experienced geotechnical personnel prior to filling or concreting to ensure that soil having adequate bearing capacity has been reached and that the bearing surfaces have been properly prepared. The placing and compaction of any engineered fill should be inspected to ensure that the materials used conform to the specifications from both a grading and compaction view point.

Ontario Regulation 903 would ultimately require abandonment of the standpipe installed for this investigation. It is proposed that decommissioning of this device be made part of the construction contract.

At the time of the writing of this report, only preliminary details for the proposed building were available. Golder Associates should be retained to review the final drawings and specifications for this project prior to tendering to ensure that the guidelines in this report have been adequately interpreted.

DRAFT



7.0 CLOSURE

We trust that this report meets your current needs. If you have any questions, or if we may be of further assistance, please do not hesitate to contact the undersigned.

GOLDER ASSOCIATES LTD.

Stephen Dunlop, P.Eng.
Geotechnical Engineer

Troy Skinner, P.Eng.
Associate, Geotechnical Engineer

SG/WAM/SD/TMS/md

\\golder.gds\gal\ottawa\active\2015\3 proj\1542724 nrc 1920 research road ottawa\08_reports\1542724 report-001 december 2015.docx

DRAFT

IMPORTANT INFORMATION AND LIMITATIONS OF THIS REPORT

Standard of Care: Golder Associates Ltd. (Golder) has prepared this report in a manner consistent with that level of care and skill ordinarily exercised by members of the engineering and science professions currently practising under similar conditions in the jurisdiction in which the services are provided, subject to the time limits and physical constraints applicable to this report. No other warranty, expressed or implied is made.

Basis and Use of the Report: This report has been prepared for the specific site, design objective, development and purpose described to Golder by the Client, National Research Council Canada. The factual data, interpretations and recommendations pertain to a specific project as described in this report and are not applicable to any other project or site location. Any change of site conditions, purpose, development plans or if the project is not initiated within eighteen months of the date of the report may alter the validity of the report. Golder can not be responsible for use of this report, or portions thereof, unless Golder is requested to review and, if necessary, revise the report.

The information, recommendations and opinions expressed in this report are for the sole benefit of the Client. No other party may use or rely on this report or any portion thereof without Golder's express written consent. If the report was prepared to be included for a specific permit application process, then the client may authorize the use of this report for such purpose by the regulatory agency as an Approved User for the specific and identified purpose of the applicable permit review process, provided this report is not noted to be a draft or preliminary report, and is specifically relevant to the project for which the application is being made. Any other use of this report by others is prohibited and is without responsibility to Golder. The report, all plans, data, drawings and other documents as well as all electronic media prepared by Golder are considered its professional work product and shall remain the copyright property of Golder, who authorizes only the Client and Approved Users to make copies of the report, but only in such quantities as are reasonably necessary for the use of the report by those parties. The Client and Approved Users may not give, lend, sell, or otherwise make available the report or any portion thereof to any other party without the express written permission of Golder. The Client acknowledges that electronic media is susceptible to unauthorized modification, deterioration and incompatibility and therefore the Client can not rely upon the electronic media versions of Golder's report or other work products.

The report is of a summary nature and is not intended to stand alone without reference to the instructions given to Golder by the Client, communications between Golder and the Client, and to any other reports prepared by Golder for the Client relative to the specific site described in the report. In order to properly understand the suggestions, recommendations and opinions expressed in this report, reference must be made to the whole of the report. Golder can not be responsible for use of portions of the report without reference to the entire report.

Unless otherwise stated, the suggestions, recommendations and opinions given in this report are intended only for the guidance of the Client in the design of the specific project. The extent and detail of investigations, including the number of test holes, necessary to determine all of the relevant conditions which may affect construction costs would normally be greater than has been carried out for design purposes. Contractors bidding on, or undertaking the work, should rely on their own investigations, as well as their own interpretations of the factual data presented in the report, as to how subsurface conditions may affect their work, including but not limited to proposed construction techniques, schedule, safety and equipment capabilities.

Soil, Rock and Groundwater Conditions: Classification and identification of soils, rocks, and geologic units have been based on commonly accepted methods employed in the practice of geotechnical engineering and related disciplines. Classification and identification of the type and condition of these materials or units involves judgment, and boundaries between different soil, rock or geologic types or units may be transitional rather than abrupt. Accordingly, Golder does not warrant or guarantee the exactness of the descriptions.

IMPORTANT INFORMATION AND LIMITATIONS OF THIS REPORT (cont'd)

Special risks occur whenever engineering or related disciplines are applied to identify subsurface conditions and even a comprehensive investigation, sampling and testing program may fail to detect all or certain subsurface conditions. The environmental, geologic, geotechnical, geochemical and hydrogeologic conditions that Golder interprets to exist between and beyond sampling points may differ from those that actually exist. In addition to soil variability, fill of variable physical and chemical composition can be present over portions of the site or on adjacent properties. **The professional services retained for this project include only the geotechnical aspects of the subsurface conditions at the site, unless otherwise specifically stated and identified in the report.** The presence or implication(s) of possible surface and/or subsurface contamination resulting from previous activities or uses of the site and/or resulting from the introduction onto the site of materials from off-site sources are outside the terms of reference for this project and have not been investigated or addressed.

Soil and groundwater conditions shown in the factual data and described in the report are the observed conditions at the time of their determination or measurement. Unless otherwise noted, those conditions form the basis of the recommendations in the report. Groundwater conditions may vary between and beyond reported locations and can be affected by annual, seasonal and meteorological conditions. The condition of the soil, rock and groundwater may be significantly altered by construction activities (traffic, excavation, groundwater level lowering, pile driving, blasting, etc.) on the site or on adjacent sites. Excavation may expose the soils to changes due to wetting, drying or frost. Unless otherwise indicated the soil must be protected from these changes during construction.

Sample Disposal: Golder will dispose of all uncontaminated soil and/or rock samples 90 days following issue of this report or, upon written request of the Client, will store uncontaminated samples and materials at the Client's expense. In the event that actual contaminated soils, fills or groundwater are encountered or are inferred to be present, all contaminated samples shall remain the property and responsibility of the Client for proper disposal.

Follow-Up and Construction Services: All details of the design were not known at the time of submission of Golder's report. Golder should be retained to review the final design, project plans and documents prior to construction, to confirm that they are consistent with the intent of Golder's report.

During construction, Golder should be retained to perform sufficient and timely observations of encountered conditions to confirm and document that the subsurface conditions do not materially differ from those interpreted conditions considered in the preparation of Golder's report and to confirm and document that construction activities do not adversely affect the suggestions, recommendations and opinions contained in Golder's report. Adequate field review, observation and testing during construction are necessary for Golder to be able to provide letters of assurance, in accordance with the requirements of many regulatory authorities. In cases where this recommendation is not followed, Golder's responsibility is limited to interpreting accurately the information encountered at the borehole locations, at the time of their initial determination or measurement during the preparation of the Report.

Changed Conditions and Drainage: Where conditions encountered at the site differ significantly from those anticipated in this report, either due to natural variability of subsurface conditions or construction activities, it is a condition of this report that Golder be notified of any changes and be provided with an opportunity to review or revise the recommendations within this report. Recognition of changed soil and rock conditions requires experience and it is recommended that Golder be employed to visit the site with sufficient frequency to detect if conditions have changed significantly.

Drainage of subsurface water is commonly required either for temporary or permanent installations for the project. Improper design or construction of drainage or dewatering can have serious consequences. Golder takes no responsibility for the effects of drainage unless specifically involved in the detailed design and construction monitoring of the system.

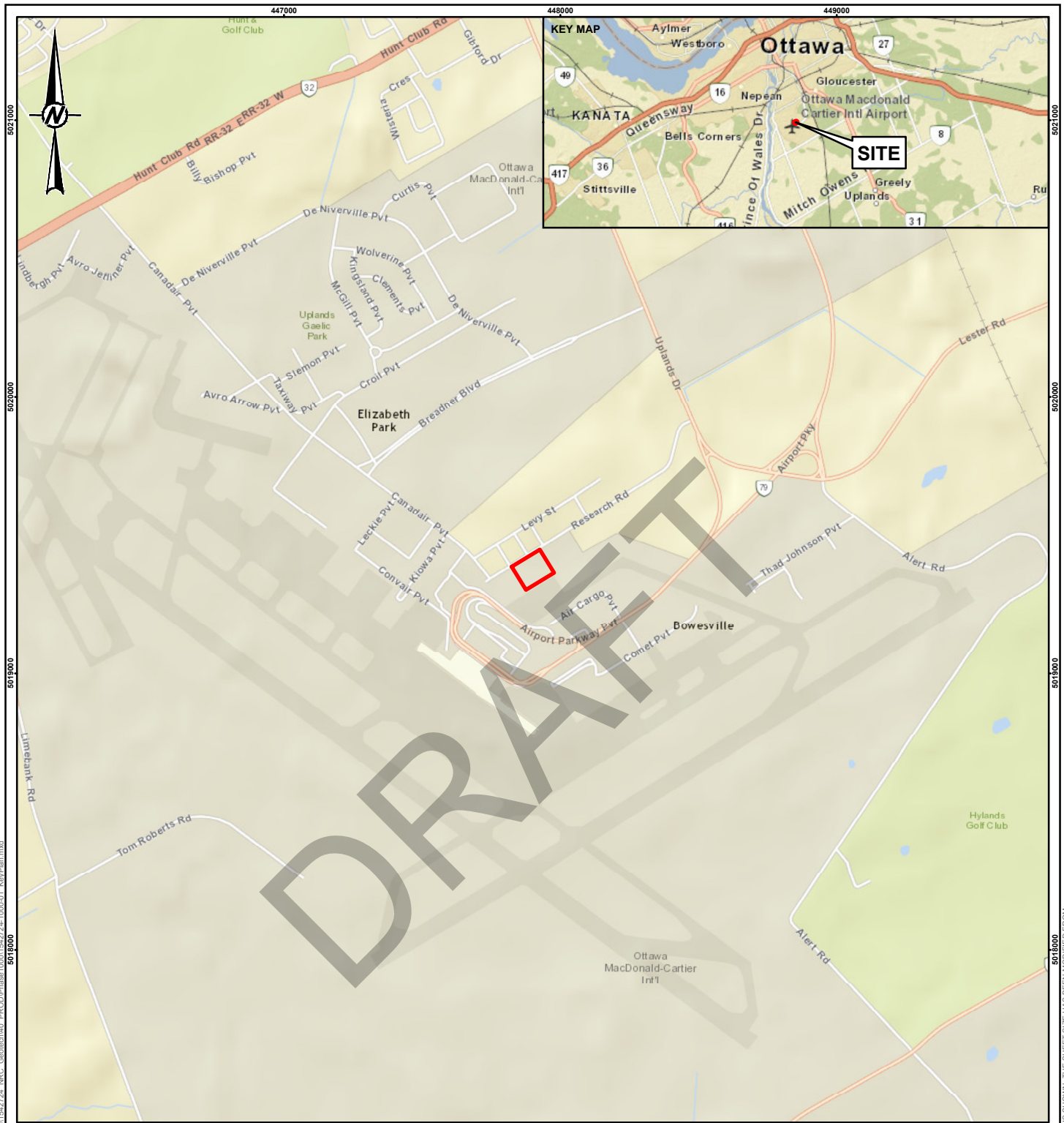

LEGEND

 SITE BOUNDARY



NOTE(S)

1. THIS FIGURE IS TO BE READ IN CONJUNCTION WITH THE ACCOMPANYING GOLDER ASSOCIATES LTD. REPORT NO. 1542724

REFERENCE(S)

1. SERVICE LAYER CREDITS: SOURCES: ESRI, HERE, DELORME, USGS, INTERMAP, INCREMENT P CORP., NRCAN, ESRI JAPAN, METI, ESRI CHINA (HONG KONG), ESRI (THAILAND), MAPMYINDIA, © OPENSTREETMAP CONTRIBUTORS, AND THE GIS USER COMMUNITY
 2. PROJECTION: TRANSVERSE MERCATOR DATUM: NAD 83
 COORDINATE SYSTEM: UTM ZONE 18 VERTICAL DATUM: CGVD28

CLIENT

NATIONAL RESEARCH COUNCIL CANADA (NRC)

PROJECT

GEOTECHNICAL INVESTIGATION, PROPOSED RESEARCH BUILDING, NRC UPLANDS CAMPUS, 1920 RESEARCH ROAD, OTTAWA, ONTARIO

TITLE

KEY PLAN

CONSULTANT



YYYY-MM-DD 2015-11-20

DESIGNED ----

PREPARED BR

REVIEWED SD

APPROVED TMS

PROJECT NO.
1542724

PHASE
1000

REV.
0



FIGURE
1

Path: N:\Active\Spatial_Im\NationalResearchCouncil\UplandsCampus\Research\Buildings\99 - PROJ\1542724 - NRC - Geotech\40 - PROJ\1542724 - 1000-01 - KeyPlan.mxd

IF THIS MEASUREMENT DOES NOT MATCH WHAT IS SHOWN, THE SHEET SIZE HAS BEEN MODIFIED FROM: 25mm



LEGEND

-  APPROXIMATE BOREHOLE LOCATION
-  PROPOSED BUILDING - U72
-  SITE BOUNDARY

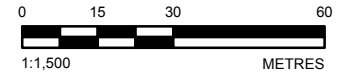
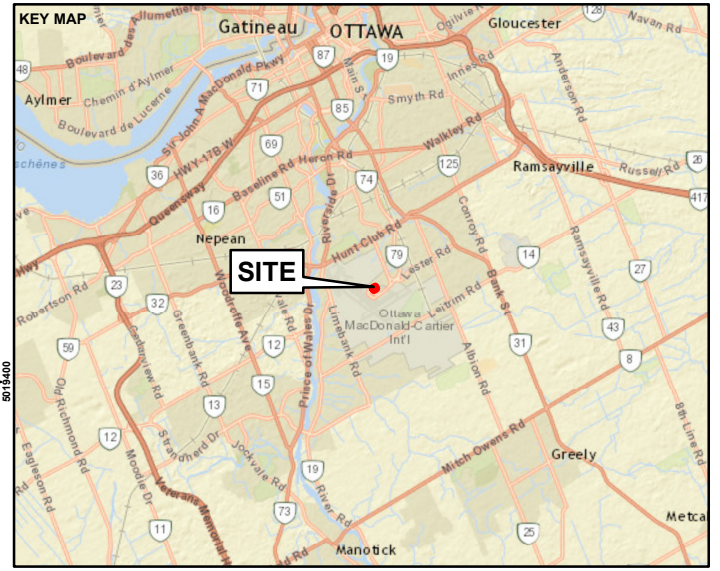

NOTE(S)

1. THIS FIGURE IS TO BE READ IN CONJUNCTION WITH THE ACCOMPANYING GOLDER ASSOCIATES LTD. REPORT NO. 1542724.

REFERENCE(S)

1. LAND INFORMATION ONTARIO (LIO) DATA PRODUCED BY GOLDER ASSOCIATES LTD. UNDER LICENCE FROM ONTARIO MINISTRY OF NATURAL RESOURCES, © QUEENS PRINTER 2014
2. SERVICE LAYER CREDITS: CITY OF OTTAWA
SOURCES: ESRI, HERE, DELORME, USGS, INTERMAP, INCREMENT P CORP., NRCAN, ESRI JAPAN, METI, ESRI CHINA (HONG KONG), ESRI (THAILAND), MAPMYINDIA, © OPENSTREETMAP CONTRIBUTORS, AND THE GIS USER COMMUNITY
3. PROJECTION: TRANSVERSE MERCATOR DATUM: NAD 83
COORDINATE SYSTEM: UTM ZONE 18 VERTICAL DATUM: CGVD28

CLIENT

NATIONAL RESEARCH COUNCIL CANADA (NRC)

PROJECT

GEOTECHNICAL INVESTIGATION, PROPOSED RESEARCH BUILDING, NRC UPLANDS CAMPUS, 1920 RESEARCH ROAD, OTTAWA, ONTARIO

TITLE

SITE PLAN

CONSULTANT	YYYY-MM-DD	2015-11-20
DESIGNED	---	
PREPARED	BR	
REVIEWED	SD	
APPROVED	TMS	



Path: N:\Vector\Spatial_1\NationalResearchCouncil\UplandsCampus\Research\Building09_PROJECT\1542724_NRC_Geotech\10_PROJECT\Phase 1000\1542724_1000_02_SitePlan.mxd

IF THIS MEASUREMENT DOES NOT MATCH WHAT IS SHOWN, THE SHEET SIZE HAS BEEN MODIFIED FROM: 26mm

GRAIN SIZE DISTRIBUTION

FIGURE 3

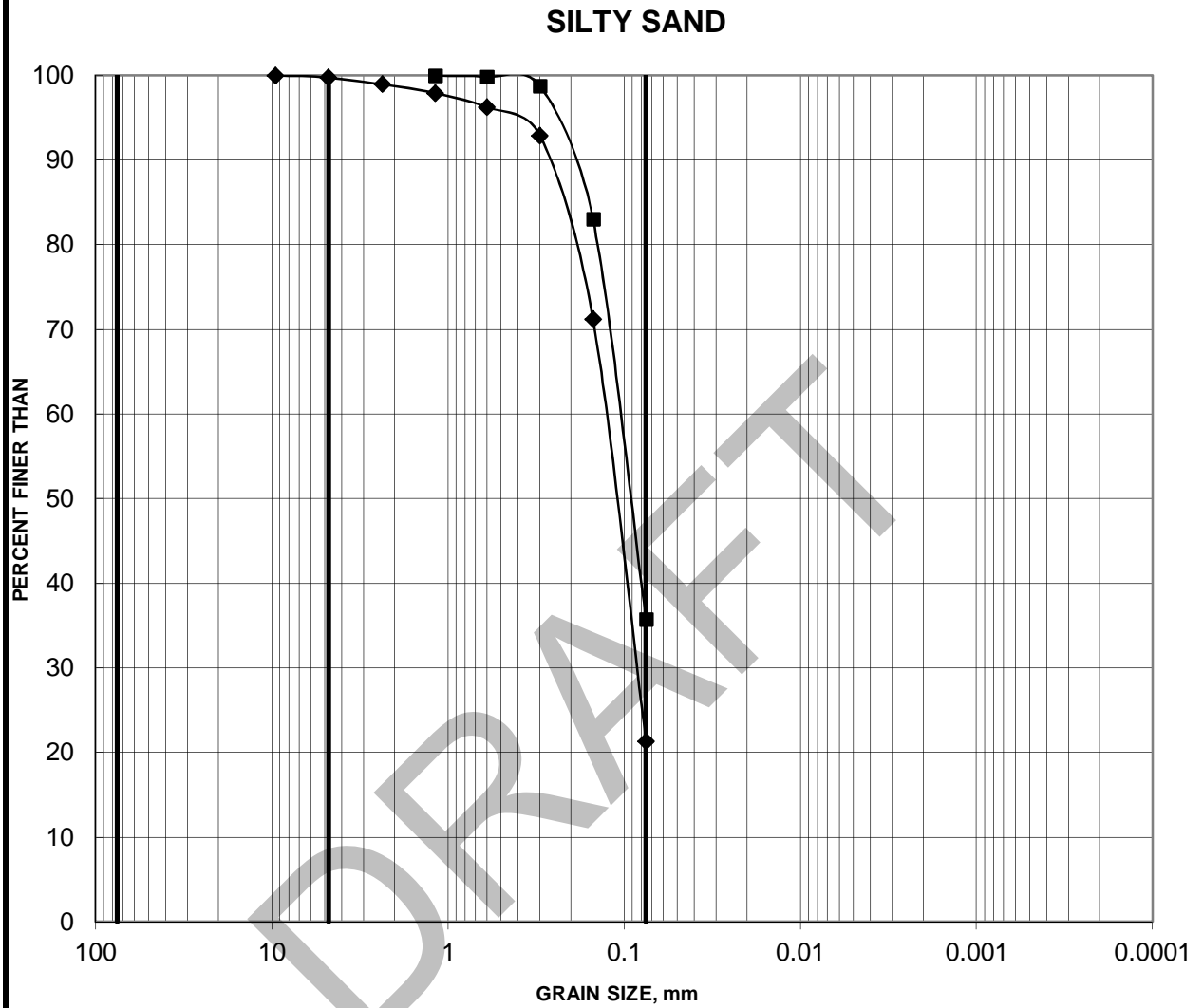

Cobble Size	coarse	fine	coarse	medium	fine	SILT AND CLAY
	GRAVEL SIZE		SAND SIZE			

Borehole	Sample	Depth (m)
15-3	7	4.57-5.18
15-4	8A	5.34-5.49



APPENDIX A

List of Abbreviations and Symbols Record of Borehole Sheets

DRAFT

LIST OF ABBREVIATIONS

The abbreviations commonly employed on Records of Boreholes, on figures, and in the text of the report are as follows:

I. SAMPLE TYPE	III. SOIL DESCRIPTION
AS Auger sample	(a) Cohesionless Soils Density Index (Relative Density) Very loose Loose Compact Dense Very dense (b) Cohesive Soils C_u or S_u Consistency Very soft Soft Firm Stiff Very stiff Hard
BS Block sample	
CS Chunk sample	
DO or DP Seamless open-ended, driven or pushed tube samplers	
DS Denison type sample	
FS Foil sample	
RC Rock core	
SC Soil core	
SS Split spoon sampler	
ST Slotted tube	
TO Thin-walled, open	
TP Thin-walled, piston	
WS Wash sample	
DT Dual tube sample	
DD Diamond drilling	

II. PENETRATION RESISTANCE

Standard Penetration Resistance (SPT), N:

The number of blows by a 63.5 kg. (140 lb.) hammer dropped 760 mm (30 in.) required to drive a 50 mm (2 in.) split spoon sampler for a distance of 300 mm (12 in.).

Dynamic Cone Penetration Resistance (DCPT); N_d:

The number of blows by a 63.5 kg (140 lb.) hammer dropped 760 mm (30 in.) to drive an uncased 50 mm (2 in.) diameter, 60° cone attached to "A" size drill rods for a distance of 300 mm (12 in.).

- PH:** Sampler advanced by hydraulic pressure
PM: Sampler advanced by manual pressure
WH: Sampler advanced by static weight of hammer
WR: Sampler advanced by weight of sampler and rod

Cone Penetration Test (CPT):

An electronic cone penetrometer with a 60° conical tip and a projected end area of 10 cm² pushed through ground at a penetration rate of 2 cm/s. Measurements of tip resistance (q_t), porewater pressure (u) and friction along a sleeve are recorded electronically at 25 mm penetration intervals.

IV. SOIL TESTS

w	Water content
w _p or PL	Plastic limited
w _l or LL	Liquid limit
C	Consolidation (oedometer) test
CHEM	Chemical analysis (refer to text)
CID	Consolidated isotropically drained triaxial test ¹
CIU	Consolidated isotropically undrained triaxial test with porewater pressure measurement ¹
D _R	Relative density
DS	Direct shear test
G _s	Specific gravity
M	Sieve analysis for particle size
MH	Combined sieve and hydrometer (H) analysis
MPC	Modified Proctor compaction test
SPC	Standard Proctor compaction test
OC	Organic content test
SO ₄	Concentration of water-soluble sulphates
UC	Unconfined compression test
UU	Unconsolidated undrained triaxial test
V	Field vane test (LV-laboratory vane test)
γ	Unit weight

Note: ¹ Tests which are anisotropically consolidated prior shear are shown as CAD, CAU.

LIST OF SYMBOLS

Unless otherwise stated, the symbols employed in the report are as follows:

I. GENERAL

π	3.1416
$\ln x$	natural logarithm of x
$\log_{10} x$ or $\log x$	logarithm of x to base 10
g	acceleration due to gravity
t	time
FOS	factor of safety
V	volume
W	weight

II. STRESS AND STRAIN

γ	shear strain
Δ	change in, e.g. in stress: $\Delta \sigma'$
ϵ	linear strain
ϵ_v	volumetric strain
η	coefficient of viscosity
ν	Poisson's ratio
σ	total stress
σ'	effective stress ($\sigma' = \sigma - u$)
σ'_{vo}	initial vertical effective overburden stress
$\sigma_1 \sigma_2 \sigma_3$	principal stresses (major, intermediate, minor)
σ_{oct}	mean stress or octahedral stress $= (\sigma_1 + \sigma_2 + \sigma_3) / 3$
τ	shear stress
u	porewater pressure
E	modulus of deformation
G	shear modulus of deformation
K	bulk modulus of compressibility

III. SOIL PROPERTIES

(a) Index Properties

$\rho(\gamma)$	bulk density (bulk unit weight)*
$\rho_d(\gamma_d)$	dry density (dry unit weight)
$\rho_w(\gamma_w)$	density (unit weight) of water
$\rho_s(\gamma_s)$	density (unit weight) of solid particles
γ'	unit weight of submerged soil ($\gamma' = \gamma - \gamma_w$)
D_R	relative density (specific gravity) of solid particles ($D_R = \rho_s / \rho_w$) formerly (G_s)
e	void ratio
n	porosity
S	degree of saturation
*	Density symbol is ρ . Unit weight symbol is γ where $\gamma = \rho g$ (i.e. mass density multiplied by acceleration due to gravity)

(a) Index Properties (continued)

w	water content
w_l or LL	liquid limit
w_p or PL	plastic limit
I_p or PI	plasticity Index = $(w_l - w_p)$
w_s	shrinkage limit
I_L	liquidity index = $(w - w_p) / I_p$
I_c	consistency index = $(w_l - w) / I_p$
e_{max}	void ratio in loosest state
e_{min}	void ratio in densest state
I_D	density index = $(e_{max} - e) / (e_{max} - e_{min})$ (formerly relative density)

(b) Hydraulic Properties

h	hydraulic head or potential
q	rate of flow
v	velocity of flow
i	hydraulic gradient
k	hydraulic conductivity (coefficient of permeability)
j	seepage force per unit volume

(c) Consolidation (one-dimensional)

C_c	compression index (normally consolidated range)
C_r	recompression index (overconsolidated range)
C_s	swelling index
C_α	coefficient of secondary consolidation
m_v	coefficient of volume change
c_v	coefficient of consolidation (vertical direction)
T_v	time factor (vertical direction)
U	degree of consolidation
σ'_p	pre-consolidation stress
OCR	overconsolidation ratio = σ'_p / σ'_{vo}

(d) Shear Strength

τ_p or τ_r	peak and residual shear strength
ϕ'	effective angle of internal friction
δ	angle of interface friction
μ	coefficient of friction = $\tan \delta$
c'	effective cohesion
c_u or s_u	undrained shear strength ($\phi = 0$ analysis)
p	mean total stress $(\sigma_1 + \sigma_3) / 2$
p'	mean effective stress $(\sigma'_1 + \sigma'_3) / 2$
q	$(\sigma_1 - \sigma_3) / 2$ or $(\sigma'_1 - \sigma'_3) / 2$
q_u	compressive strength $(\sigma_1 - \sigma_3)$
S_t	sensitivity

Notes: ¹ $\tau = c' + \sigma' \tan \phi'$

² shear strength = (compressive strength) / 2

PROJECT: 1542724

RECORD OF BOREHOLE: 15-1

SHEET 1 OF 1

LOCATION: N 5019342.2 ; E 447855.1

BORING DATE: October 30, 2015

DATUM: Geodetic

SAMPLER HAMMER, 64kg; DROP, 760mm

PENETRATION TEST HAMMER, 64kg; DROP, 760mm

DEPTH SCALE METRES	BORING METHOD	SOIL PROFILE		SAMPLES		DYNAMIC PENETRATION RESISTANCE, BLOWS/0.3m				HYDRAULIC CONDUCTIVITY, k, cm/s				ADDITIONAL LAB. TESTING	PIEZOMETER OR STANDPIPE INSTALLATION	
		DESCRIPTION	STRATA PLOT	ELEV. DEPTH (m)	NUMBER	TYPE	SHEAR STRENGTH				WATER CONTENT PERCENT					
							20 40 60 80		nat V. + Q - rem V. ⊕ U - ⊙		10 ⁻⁶ 10 ⁻⁵ 10 ⁻⁴ 10 ⁻³		Wp ----- W ----- WI			
0		GROUND SURFACE		113.78												
		TOPSOIL		0.00												
		(SM) SILTY SAND, some gravel to gravelly; dark brown, with cobbles; non-cohesive, moist, compact to dense		113.48 0.30	1	SS	11									
1					2	SS	43									
					3	SS	48									
2		(SP) SAND, fine, trace gravel; brown; non-cohesive, moist, compact		111.65 2.13												
		(SM) SILTY SAND, fine, trace gravel; red brown, with clayey silt seams; non-cohesive, moist, compact		111.34 2.44	4	SS	13									
3	Power Auger 200 mm Diam. (Hollow Stem)	(SP) SAND, fine, trace gravel; grey brown, with silt seams; non-cohesive; moist, compact		110.89 2.89	5	SS	22									
		(SW/GW) SAND and GRAVEL; grey brown, with cobbles and boulders; non-cohesive, moist, very dense		110.13 3.65	6	SS	>50									
4					7	SS	82									
5					8	SS	>50									
6		End of Borehole Auger Refusal on Probable Boulder		107.69 6.09												
7																
8																
9																
10																

DRAFT

MIS-BHS 001 1542724.GPJ GAL-MIS.GDT 12/15/15 JM



PROJECT: 1542724

RECORD OF BOREHOLE: 15-2

SHEET 1 OF 1

LOCATION: N 5019316.4 ;E 447871.5

BORING DATE: October 30, 2015

DATUM: Geodetic

SAMPLER HAMMER, 64kg; DROP, 760mm

PENETRATION TEST HAMMER, 64kg; DROP, 760mm

DEPTH SCALE METRES	BORING METHOD	SOIL PROFILE		SAMPLES		DYNAMIC PENETRATION RESISTANCE, BLOWS/0.3m				HYDRAULIC CONDUCTIVITY, k, cm/s				ADDITIONAL LAB. TESTING	PIEZOMETER OR STANDPIPE INSTALLATION	
		DESCRIPTION	STRATA PLOT	ELEV. DEPTH (m)	NUMBER	TYPE	BLOWS/0.30m				WATER CONTENT PERCENT					
							SHEAR STRENGTH Cu, kPa		nat V. + rem V. ⊕ ⊙		10 ⁻⁶ 10 ⁻⁵ 10 ⁻⁴ 10 ⁻³		Wp			W
0		GROUND SURFACE		113.91												
		TOPSOIL		0.00												
		(SM) SILTY SAND, some gravel to gravelly; dark brown; non-cohesive, moist, compact to very dense		113.71	1	SS	13									
1				0.20												
					2	SS	57									
					3	SS	21									
2				111.78												
		(SP) SAND; red brown, with clayey silt seams; non-cohesive, moist, loose		2.13												
					4	SS	5									
3	Power Auger 200 mm Diam. (Hollow Stem)			111.02												
		(SM) gravelly SILTY SAND; dark brown, with cobbles; non-cohesive, moist, compact		2.89												
					5	SS	19									
4				110.26												
		(SW/GW) SAND and GRAVEL; grey brown, with cobbles and boulders; non-cohesive, moist, very dense		3.65												
					6	SS	83									
5				108.58												
		End of Borehole Auger Refusal on Probable Boulder		5.33												
					7	SS	>50									
6																
7																
8																
9																
10																

DRAFT

MIS-BHS 001 1542724.GPJ GAL-MIS.GDT 12/15/15 JM

DEPTH SCALE

1 : 50



LOGGED: DG

CHECKED: SD

PROJECT: 1542724

RECORD OF BOREHOLE: 15-3

SHEET 1 OF 3

LOCATION: N 5019364.2 ; E 447891.6

BORING DATE: October 30, 2015

DATUM: Geodetic

SAMPLER HAMMER, 64kg; DROP, 760mm

PENETRATION TEST HAMMER, 64kg; DROP, 760mm

DEPTH SCALE METRES	BORING METHOD	SOIL PROFILE		SAMPLES		DYNAMIC PENETRATION RESISTANCE, BLOWS/0.3m				HYDRAULIC CONDUCTIVITY, k, cm/s				ADDITIONAL LAB. TESTING	PIEZOMETER OR STANDPIPE INSTALLATION	
		DESCRIPTION	STRATA PLOT	ELEV. DEPTH (m)	NUMBER	TYPE	20 40 60 80				10 ⁻⁶ 10 ⁻⁵ 10 ⁻⁴ 10 ⁻³					
							SHEAR STRENGTH Cu, kPa		nat V. + rem V. ⊕ ⊖		Q - U - ⊙		WATER CONTENT PERCENT Wp W Wi			
0		GROUND SURFACE		113.02												
		TOPSOIL		0.00												
		(SM) SILTY SAND, some gravel to gravelly; dark brown; non-cohesive, moist, compact		0.15	1	SS	12									
1				111.65	2	SS	13									
		(SP) SAND, fine to medium; light brown; non-cohesive, moist, compact		1.37												
		(SM) SILTY SAND, fine to medium, some gravel; dark brown; non-cohesive, moist, compact to loose		111.35	3	SS	27									
2				1.67												
		(CI) SILTY CLAY, trace sand; grey brown, highly fissured (WEATHERED CRUST); cohesive, w>PL, very stiff		110.13	4	SS	7									
3				2.89	5	SS	9									
		(SM) SILTY SAND, fine; grey, with clayey silt seams; non-cohesive, wet, compact to loose		109.37	6	SS	11									
4				3.65	7	SS	4									
5				107.84	8	SS	4									
		(CI) SILTY CLAY; grey brown; cohesive, w>PL, stiff		5.18												
6		Unsampled Overburden Dynamic Cone Penetration Test (DCPT)		106.93												
7				6.09												
8	DCPT AW Rods															
9																
10																

CONTINUED NEXT PAGE

MIS-BHS 001 1542724.GPJ GAL-MIS.GDT 12/15/15 JM

DEPTH SCALE

1 : 50



LOGGED: DG

CHECKED: SD

PROJECT: 1542724

RECORD OF BOREHOLE: 15-3

SHEET 2 OF 3

LOCATION: N 5019364.2 ; E 447891.6

BORING DATE: October 30, 2015

DATUM: Geodetic

SAMPLER HAMMER, 64kg; DROP, 760mm

PENETRATION TEST HAMMER, 64kg; DROP, 760mm

DEPTH SCALE METRES	BORING METHOD	SOIL PROFILE		SAMPLES		DYNAMIC PENETRATION RESISTANCE, BLOWS/0.3m				HYDRAULIC CONDUCTIVITY, k, cm/s				ADDITIONAL LAB. TESTING	PIEZOMETER OR STANDPIPE INSTALLATION	
		DESCRIPTION	STRATA PLOT	ELEV. DEPTH (m)	NUMBER	TYPE	20		40		10 ⁻⁶		10 ⁻⁵			
							SHEAR STRENGTH Cu, kPa		nat V. + rem V. ⊕		Q - U - ○		WATER CONTENT PERCENT Wp W Wi			
10	DCPT AW Rods	--- CONTINUED FROM PREVIOUS PAGE ---														
11		Unsamed Overburden Dynamic Cone Penetration Test (DCPT)														
12																
13																
14																
15																
16																
17																
18																
19																
20																
		CONTINUED NEXT PAGE														

DRAFT

MIS-BHS 001 1542724.GPJ GAL-MIS.GDT 12/15/15 JM



PROJECT: 1542724

RECORD OF BOREHOLE: 15-3

SHEET 3 OF 3

LOCATION: N 5019364.2 ;E 447891.6

BORING DATE: October 30, 2015

DATUM: Geodetic

SAMPLER HAMMER, 64kg; DROP, 760mm

PENETRATION TEST HAMMER, 64kg; DROP, 760mm

DEPTH SCALE METRES	BORING METHOD	SOIL PROFILE		SAMPLES		DYNAMIC PENETRATION RESISTANCE, BLOWS/0.3m				HYDRAULIC CONDUCTIVITY, k, cm/s				ADDITIONAL LAB. TESTING	PIEZOMETER OR STANDPIPE INSTALLATION	
		DESCRIPTION	STRATA PLOT	ELEV. DEPTH (m)	NUMBER	TYPE	20 40 60 80		10 ⁻⁶ 10 ⁻⁵ 10 ⁻⁴ 10 ⁻³		WATER CONTENT PERCENT					
							SHEAR STRENGTH Cu, kPa		nat V. + Q - rem V. ⊕ U - ⊙		Wp ----- W ----- WI					
20	DCPT AW Rods	--- CONTINUED FROM PREVIOUS PAGE --- Unsamed Overburden Dynamic Cone Penetration Test (DCPT)														
21																
22																
23																
24																
25			End of Borehole/DCPT	88.02 25.00												
26																
27																
28																
29																
30																

DRAFT

MIS-BHS 001 1542724.GPJ GAL-MIS.GDT 12/15/15 JM



PROJECT: 1542724

RECORD OF BOREHOLE: 15-4

SHEET 1 OF 1

LOCATION: N 5019338.5 ; E 447908.2

BORING DATE: October 30, 2015

DATUM: Geodetic

SAMPLER HAMMER, 64kg; DROP, 760mm

PENETRATION TEST HAMMER, 64kg; DROP, 760mm

DEPTH SCALE METRES	BORING METHOD	SOIL PROFILE		SAMPLES		DYNAMIC PENETRATION RESISTANCE, BLOWS/0.3m				HYDRAULIC CONDUCTIVITY, k, cm/s				ADDITIONAL LAB. TESTING	PIEZOMETER OR STANDPIPE INSTALLATION	
		DESCRIPTION	STRATA PLOT	ELEV. DEPTH (m)	NUMBER	TYPE	SHEAR STRENGTH Cu, kPa				WATER CONTENT PERCENT					
							20	40	60	80	nat V. + rem V. ⊕	Q - U - ●	10 ⁻⁶			10 ⁻⁵
0	Power Auger 200 mm Diam. (Hollow Stem)	GROUND SURFACE		113.27												
		TOPSOIL		0.00												
		(SM) SILTY SAND, some gravel to gravelly; dark brown, with cobbles; non-cohesive, moist, very loose to loose		0.12	1	SS	5								Bentonite Seal	
1					2	SS	2									
					3	SS	3									
2					4	SS	6								Native Backfill	
					5	SS	8									
3			(SM) SILTY SAND, fine; brown, with clayey silt seams; non-cohesive, moist to wet, loose		110.38											
					2.89	5	SS	8								
4					6	SS	6								Bentonite Seal	
				7	SS	9										
5				8	SS	6										
				107.78												
		(Cl) SILTY CLAY; grey; cohesive, w>PL, very stiff		5.49	8	SS	6									
6				107.18												
		End of Borehole		6.09												
7																
8																
9																
10																

DRAFT

WL in Standpipe at Elev. 109.36 m on Nov. 5, 2015

MIS-BHS 001 1542724.GPJ GAL-MIS.GDT 12/15/15 JM

DEPTH SCALE

1 : 50



LOGGED: DG

CHECKED: SD



APPENDIX B

**Results of Chemical Analysis
EXOVA Laboratories Report No. 1522272**

DRAFT

Client: Golder Associates Ltd. (Ottawa)
1931 Robertson Road
Ottawa, ON
K2H 5B7
Attention: Mr. Alex Meacoe
PO#:
Invoice to: Golder Associates Ltd. (Ottawa)

Report Number: 1522272
Date Submitted: 2015-11-09
Date Reported: 2015-11-17
Project: 1542724
COC #: 803128

Page 1 of 2

Dear Alex Meacoe:

Please find attached the analytical results for your samples. If you have any questions regarding this report, please do not hesitate to call (613-727-5692).

Report Comments:



Shyla Monette
2015.11.17
15:47:27 -05'00'

APPROVAL: _____

Shyla Monette
Team Leader, Inorganics

All analysis is completed in Ottawa, Ontario (unless otherwise indicated).

Exova Ottawa is accredited by CALA, Canadian Association for Laboratory Accreditation to ISO/IEC 17025 for tests which appear on our CALA scope of accreditation. It can be found at <http://www.cala.ca/scopes/2602.pdf>.

Exova (Ottawa) is certified and accredited for specific parameters by OMAFRA, Ontario Ministry of Agriculture, Food and Rural Affairs (for farm soils). Licensed by Ontario MOE for specific tests in drinking water.

Exova (Mississauga) is accredited for specific parameters by SCC, Standards Council of Canada (to ISO 17025)

Please note: Field data, where presented on the report, has been provided by the client and is presented for informational purposes only. Guideline values listed on this report are provided for ease of use (informational purposes) only. Exova recommends consulting the official provincial or federal guideline as required.

Client: Golder Associates Ltd. (Ottawa)
 1931 Robertson Road
 Ottawa, ON
 K2H 5B7
 Attention: Mr. Alex Meacoe
 PO#:
 Invoice to: Golder Associates Ltd. (Ottawa)

Report Number: 1522272
 Date Submitted: 2015-11-09
 Date Reported: 2015-11-17
 Project: 1542724
 COC #: 803128

Lab I.D.	1212712
Sample Matrix	Soil
Sample Type	
Sampling Date	2015-10-30
Sample I.D.	BH15-1 sa3 5-7

Group	Analyte	MRL	Units	Guideline	
Agri. - Soil	pH	2.0			8.2
General Chemistry	Cl	0.002	%		0.003
	Electrical Conductivity	0.05	mS/cm		0.16
	Resistivity	1	ohm-cm		6250
	SO4	0.01	%		<0.01

DRAFT

Guideline = *** = Guideline Exceedence**
 All analysis completed in Ottawa, Ontario (unless otherwise indicated by ** which indicates analysis was completed in Mississauga, Ontario).
 Results relate only to the parameters tested on the samples submitted.
 Methods references and/or additional QA/QC information available on request.

MRL = Method Reporting Limit, AO = Aesthetic Objective, OG = Operational Guideline, MAC = Maximum Acceptable Concentration, IMAC = Interim Maximum Acceptable Concentration, STD = Standard, PWQO = Provincial Water Quality Guideline, IPWQO = Interim Provincial Water Quality Objective, TDR = Typical Desired Range

At Golder Associates we strive to be the most respected global group of companies specializing in ground engineering and environmental services. Employee owned since our formation in 1960, we have created a unique culture with pride in ownership, resulting in long-term organizational stability. Golder professionals take the time to build an understanding of client needs and of the specific environments in which they operate. We continue to expand our technical capabilities and have experienced steady growth with employees now operating from offices located throughout Africa, Asia, Australasia, Europe, North America and South America.

Africa	+ 27 11 254 4800
Asia	+ 852 2562 3658
Australasia	+ 61 3 8862 3500
Europe	+ 356 21 42 30 20
North America	+ 1 800 275 3281
South America	+ 55 21 3095 9500

solutions@golder.com
www.golder.com

DRAFT

Golder Associates Ltd.
1931 Robertson Road
Ottawa, Ontario, K2H 5B7
Canada
T: +1 (613) 592 9600



BUILDING U-72 FLIGHT RESEARCH LABORATORY NRC , OTTAWA



GENERAL NOTES

- CONTRACTORS TO CHECK AND VERIFY ALL DIMENSIONS ON SITE PRIOR TO DEMOLITION OR CONSTRUCTION AND REPORT ANY ERRORS OR OMISSIONS TO DEPARTMENTAL REPRESENTATIVE.
- CONTRACTORS MUST VISIT THE SITE & FULLY FAMILIARIZE THEMSELVES WITH THE SCOPE OF THE WORK.
- PREVENT THE SPREAD OF DUST & DEBRIS BEYOND THE WORK AREA AND CLEAN ALL SURFACES AT COMPLETION.
- MAKE GOOD ALL SURFACES AFFECTED BY THIS WORK.
- COORDINATE ALL SHUTDOWNS WITH THE DEPARTMENTAL REPRESENTATIVE.
- PROVIDE ALL LABOUR AND MATERIAL REQUIRED TO FORM A COMPLETE, FUNCTIONAL SYSTEM AS DESCRIBED ON DRAWINGS.

No.	Date	Revision	By:
1	JUNE 15 2016	ISSUED FOR 50% REVIEW	KWC

Date Printed: _____ Date imprimée: _____

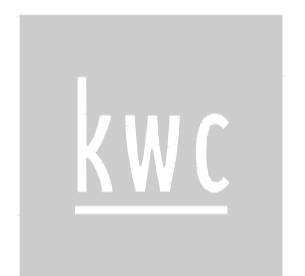

383 Parkdale Avenue, Suite 201
Ottawa Ontario Canada K1Y 4R4
KWC ARCHITECTS INC.
PHONE (613) 238-2117
FAX (613) 238-6595
E MAIL kwc@kwc-arch.com

- Verify all dimensions and site conditions and be responsible for same
- Vérifier toutes les dimensions et l'état des lieux et en assumer la responsabilité

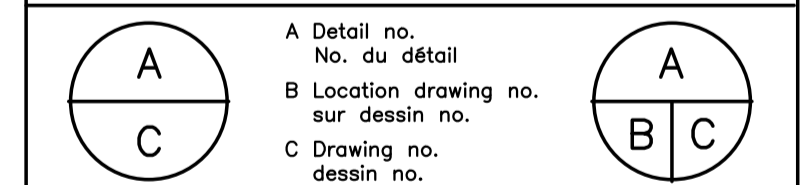

project **U-72 FLIGHT RESEARCH FACILITY UPLANDS CAMPUS** projet

OTTAWA, ON

drawing **COVER SHEET** dessin

designed **CD/MM** conçu **JUNE 2016** date

drawn **CD/MM** dessiné **AS NOTED** scale échelle

checked **MM** vérifié sheet **1** of/de **XX** feuille

approved **MM** approuvé W.O.no. **XX** D.T.no.

dwg.no. **A00** dessin no.

DRAWING LIST

- COVER SHEET
- ARCHITECTURAL
- STRUCTURAL
- MECHANICAL
- ELECTRICAL

LEGEND

APPLICABLE TO ALL ARCHITECTURAL DRAWINGS :

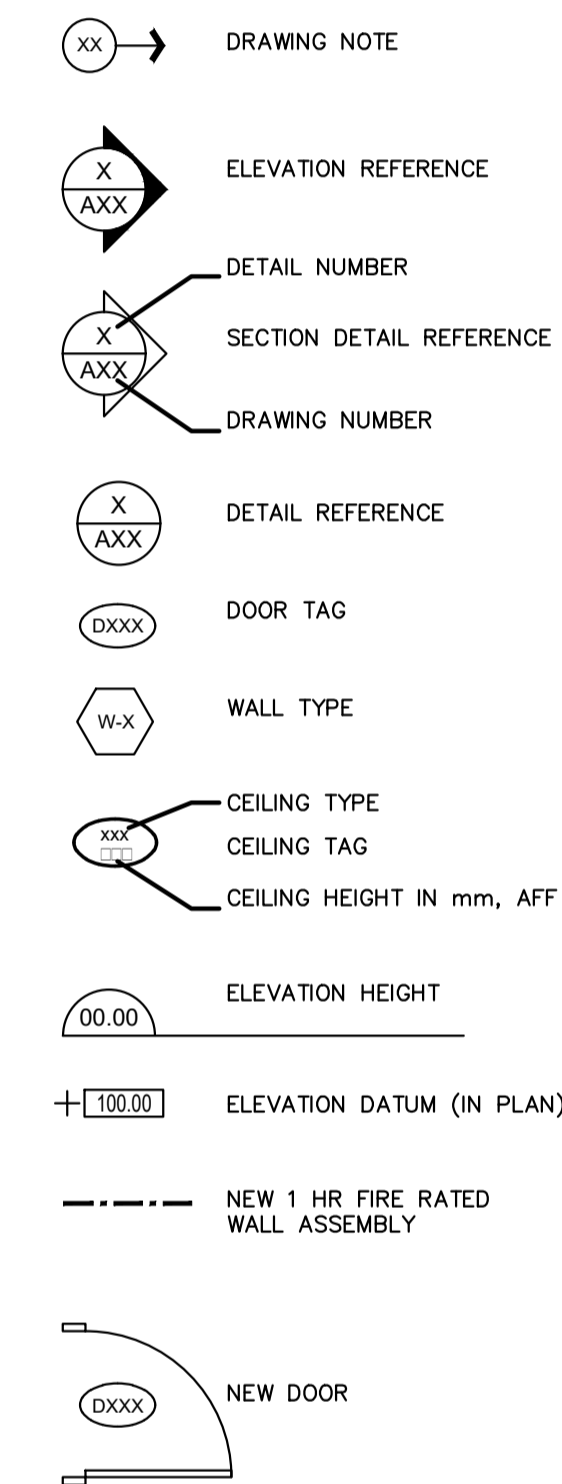

ABBREVIATIONS

Ø	DIAMETRE	#R	RISERS
AWB	ALUMINUM WALL BASE	RD	ROOF DRAIN
ACT-1	ACOUSTIC CEILING TILE	REV	REVERSE
BR	BACKREST	RSD	ROLLING STEEL DOOR
CH	COAT HOOK	RWB	RESILIENT WALL BASE
CL	CENTRE LINE	SD	SOAP DISPENSOR
CONC	CONCRETE	SIM	SIMILAR
CPT	CARPET	SN	STAIN FINISH
CMU	CONCRETE MASONRY UNIT	SP	SPRINKLER HEAD
CR	CURTAIN ROD	TG	TEMPERED GLASS
C/W	COMPLETE WITH	TI	TAPERED INSULATION
DA	DOOR ACTUATOR BUTTON	T/O	TOP OF
DMNT	DEMOUNTABLE	TP	TOILET PAPER DISPENSER
DN	DOWN	TPS	THERMALLY BROKEN PRESSED STEEL
DWG	DRAWING	TYP	TYPICAL
EPF	EPOXY FLOOR FINISH	U/S	UNDERSIDE
EPST	EXPOSED STRUCTURE AND ROOF DECK	VCT	VINYL COMPOSITION TILE
EPT	EPOXY PAINT	VMB	VINYL WALL BASE
EQ	EQUAL	WC	TOILET
EX	EXISTING	WD	WOOD
EXT.	EXTERIOR	WT	WALL TILE
FD	FLOOR DRAIN	WGB	WATERPROOF GYPSUM BOARD
FFL	FINISHED FLOOR LEVEL	WHS	WALL HUNG SINK
FHC	RECESSED FIRE HOSE CABINET	WR	RECESSED WASTE RECEPTACLE
FLR	FLOOR		
FRP	FIBREGLASS REINFORCED PLASTIC		
GB	GYPSUM BOARD		
GL	INSULATED GLASS, SEE SPECS		
GRB	GRAB BAR		
HM	HOLLOW METAL		
HS	HOOK STRIP		
INT.	INTERIOR		
LNR	METAL LINER		
MR	MIRROR		
ND	SANITARY NAPKIN DISPOSAL		
NTS	NOT TO SCALE		
OC	ON CENTER		
PDO	POWER DOOR OPERATOR		
PF	PRE-FINISHED		
PS	PRESSED STEEL		
PT	PAINT		

PARTITION WALLS:NEW CONSTRUCTION

W1 EXTERIOR WALL
PRE-FINISHED METAL SIDING ON 175mm GALVANIZED METAL HORIZONTAL "Z" BAR FRAMING
150mm SEMI RIGID INSULATION
HORIZONTAL STRUCTURAL GIRTS.

P1 INTERIOR WALL
16MM GYPSUM BOARD, PAINT FINISH, ON EACH SIDE OF 92MM METAL STUD AT 400 O.C. EXTEND STUD FRAMING FROM TOP OF SLAB TO UNDERSIDE OF STEEL DECK ABOVE.

R1 ROOF ASSEMBLY
- 2-PLY MODIFIED BITUMEN ROOF MEMBRANE
- 6mm PROTECTION BOARD
- TAPERED INSULATION, THICKNESS VARIES, SEE ROOF PLAN
- 2 LAYERS OF 75mm INSULATION, SHIP-LAPPED JOINTS
- 13mm GLASS FACED GYPSUM BOARD
- ROOF DECK, SEE STRUCTURAL DRAWINGS, PAINT UNDERSIDE
- OPEN WEB STEEL JOISTS, SEE STRUCTURAL DRAWINGS, PAINT FINISH

R2 PARAPET ASSEMBLY
2-PLY MODIFIED BITUMEN ROOF MEMBRANE
PRIMER OR ADHESIVE
19mm PRESSURE TREATED PLYWOOD
38x89mm PRESSURE TREATED WOOD STUD AT 400mm OC
89 MINERAL FIBRE INSULATION

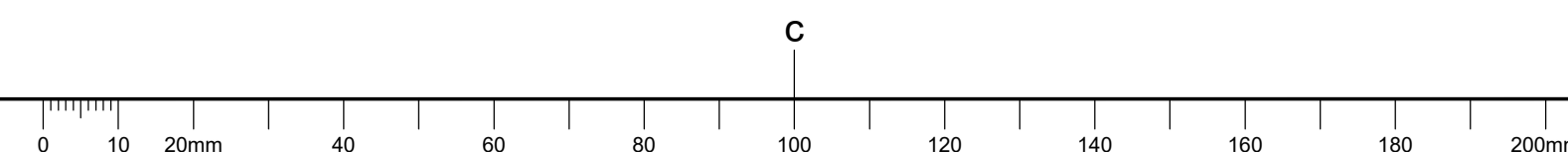

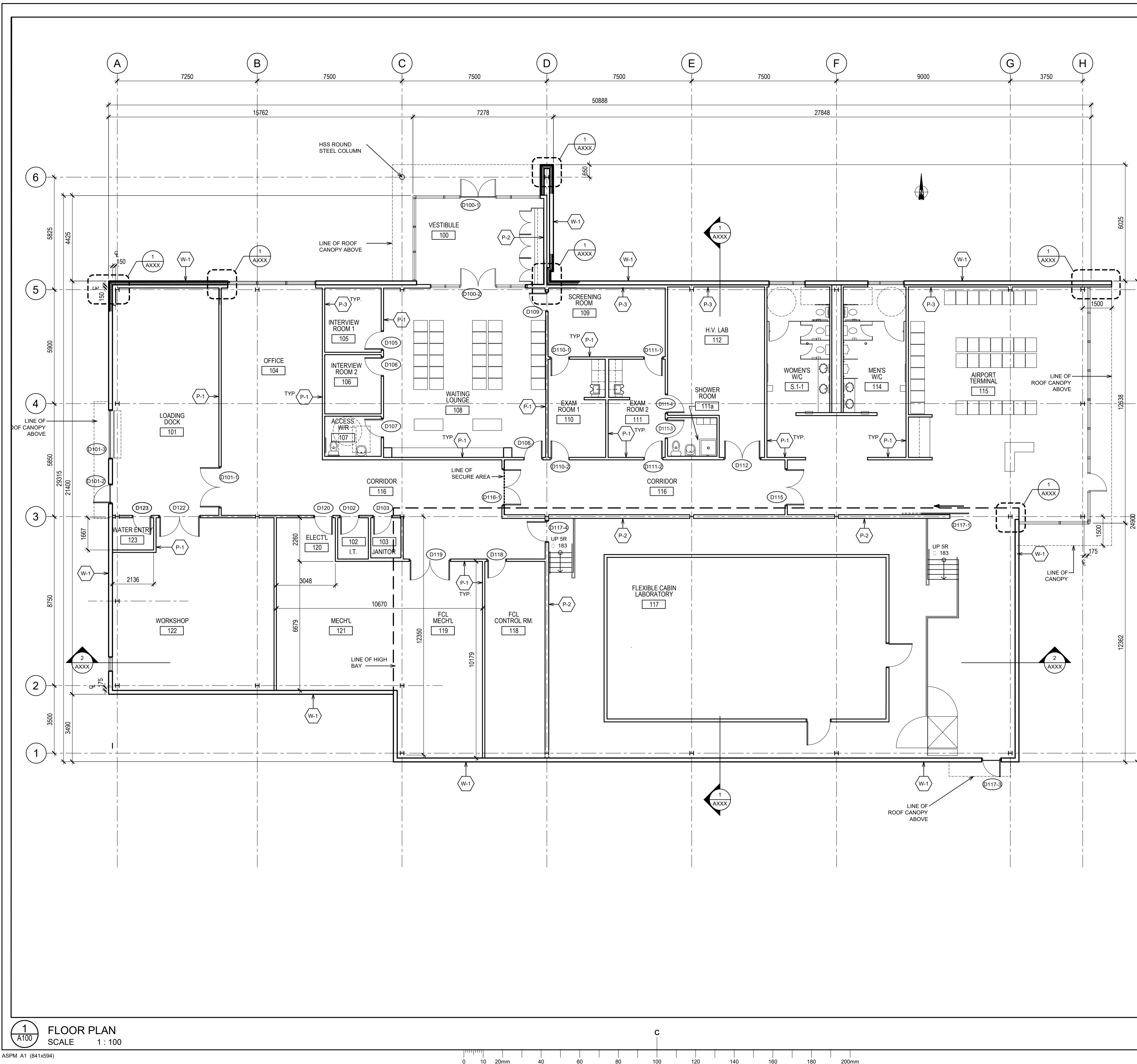

GENERAL NOTES

PRIOR TO COMMENCEMENT OF WORK, NOTIFY DEPARTMENTAL REPRESENTATIVE OF ANY DISCREPANCIES NOTED IN THE CONTRACT DOCUMENTS.

A. ALL GRID TO GRID DIMENSIONS ARE PLUS/MINUS. PRIOR TO COMMENCEMENT OF WORK, REVIEW SITE CONDITIONS AND VERIFY ALL DIMENSIONS. NOTIFY DEPARTMENTAL REPRESENTATIVE OF ANY DISCREPANCIES.

B. DO NOT SCALE DRAWINGS.

C. ALL DIMENSIONS ARE INDICATED IN MILLIMETERS UNLESS OTHERWISE SPECIFIED.

DRAWING NOTES - SHEET A101

THESE NOTES APPLY TO DRAWING SHEET A101 ONLY

01 XXXXXXX.

02 XXXXXXXXX.

GENERAL NOTES

- CONTRACTORS TO CHECK AND VERIFY ALL DIMENSIONS ON SITE PRIOR TO DEMOLITION OR CONSTRUCTION AND REPORT ANY ERRORS OR OMISSIONS TO DEPARTMENTAL REPRESENTATIVE.
- CONTRACTORS MUST VISIT THE SITE & FULLY FAMILIARIZE THEMSELVES WITH THE SCOPE OF THE WORK.
- PREVENT THE SPREAD OF DUST & DEBRIS BEYOND THE WORK AREA AND CLEAN ALL SURFACES AT COMPLETION.
- MAKE GOOD ALL SURFACES AFFECTED BY THIS WORK.
- COORDINATE ALL SHUTDOWNS WITH THE DEPARTMENTAL REPRESENTATIVE.
- PROVIDE ALL LABOUR AND MATERIAL REQUIRED TO FORM A COMPLETE, FUNCTIONAL SYSTEM AS DESCRIBED ON DRAWINGS.

No.	Date	Revision	By:	For:
1	JUNE 15 2016	ISSUED FOR 50% REVIEW	KWC	

Date Printed		Date imprimée	
--------------	--	---------------	--

383 Parkdale Avenue, Suite 201
Ottawa Ontario Canada K1Y 4R4

KWC ARCHITECTS INC.

PHONE: (613) 238-2117
FAX: (613) 238-6595
E MAIL: kwc@kwc-arch.com

- Verify all dimensions and site conditions and be responsible for same
- Vérifier toutes les dimensions et l'état des lieux et en assumer la responsabilité

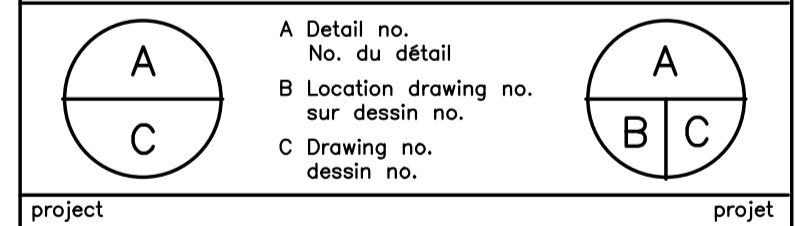

project: **NRC U72 FLIGHT RESEARCH FACILITY UPLANDS CAMPUS**

project: **OTTAWA, ON**

drawing: **FLOOR PLAN**

designed	conçu	date	date
CD/ MM		JUNE 2016	
drawn	dessiné	scale	échelle
CD/MM		1:100	
checked	vérifié	sheet	feuille
MM		- of/de -	
approved	approuvé	W.O.no.	D.T.no.
MM		----	
dwg.no.			dessin no.

A101

1
A100

FLOOR PLAN
SCALE 1:100

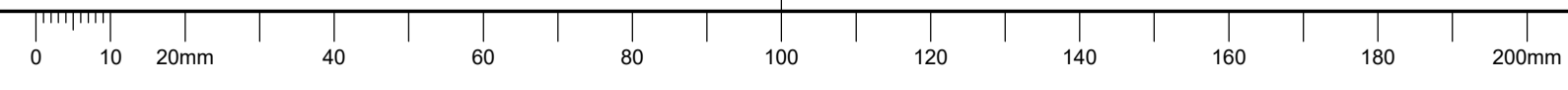

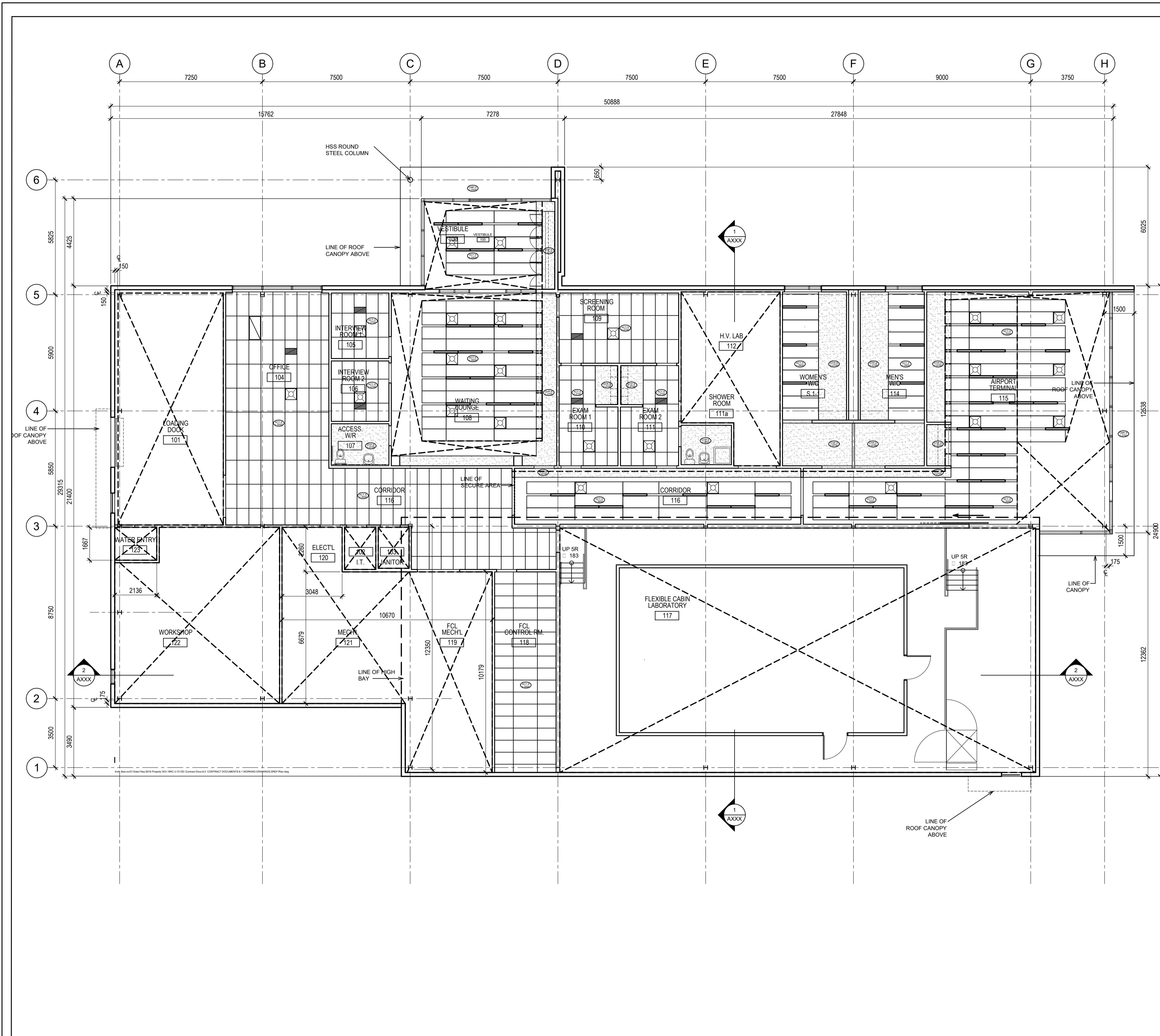

GENERAL NOTES

PRIOR TO COMMENCEMENT OF WORK, NOTIFY DEPARTMENTAL REPRESENTATIVE OF ANY DISCREPANCIES NOTED IN THE CONTRACT DOCUMENTS.

A. ALL GRID TO GRID DIMENSIONS ARE PLUS/MINUS. PRIOR TO COMMENCEMENT OF WORK, REVIEW SITE CONDITIONS AND VERIFY ALL DIMENSIONS. NOTIFY DEPARTMENTAL REPRESENTATIVE OF ANY DISCREPANCIES.

B. DO NOT SCALE DRAWINGS.

C. ALL DIMENSIONS ARE INDICATED IN MILLIMETERS UNLESS OTHERWISE SPECIFIED.

DRAWING NOTES - SHEET A102

THESE NOTES APPLY TO DRAWING SHEET A102 ONLY

01 XXXXXXXX.

02 XXXXXXXX.

NRC - CNRC

National Research Council Canada / Conseil national de recherches Canada

Administrative Services and Property Management Branch / Division des services administratifs et gestion de l'immobilier

- GENERAL NOTES**
- CONTRACTORS TO CHECK AND VERIFY ALL DIMENSIONS ON SITE PRIOR TO DEMOLITION OR CONSTRUCTION AND REPORT ANY ERRORS OR OMISSIONS TO DEPARTMENTAL REPRESENTATIVE.
 - CONTRACTORS MUST VISIT THE SITE & FULLY FAMILIARIZE THEMSELVES WITH THE SCOPE OF THE WORK.
 - PREVENT THE SPREAD OF DUST & DEBRIS BEYOND THE WORK AREA AND CLEAN ALL SURFACES AT COMPLETION.
 - MAKE GOOD ALL SURFACES AFFECTED BY THIS WORK.
 - COORDINATE ALL SHUTDOWNS WITH THE DEPARTMENTAL REPRESENTATIVE.
 - PROVIDE ALL LABOUR AND MATERIAL REQUIRED TO FORM A COMPLETE, FUNCTIONAL SYSTEM AS DESCRIBED ON DRAWINGS.

No.	Date	Revision	By:
1	JUNE 15 2016	ISSUED FOR 50% REVIEW	KWC

kwc

383 Parkdale Avenue, Suite 201
Ottawa Ontario Canada K1Y 4R4

KWC ARCHITECTS INC.

PHONE: (613) 238-2117
FAX: (613) 238-6595
E-MAIL: kw@kwc-arch.com

- Verify all dimensions and site conditions and be responsible for same
- Vérifier toutes les dimensions et l'état des lieux et en assumer la responsabilité

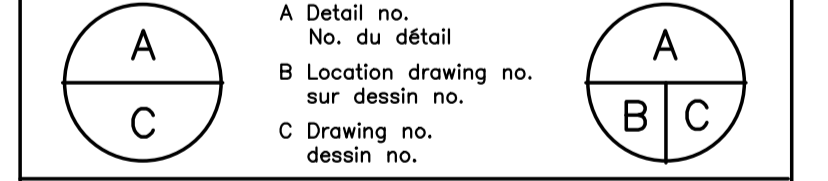

project: **NRC U72 FLIGHT RESEARCH FACILITY UPLANDS CAMPUS**

drawing: **OTTAWA, ON REFLECTED CEILING PLAN**

designed	conçu	date	date
MM/CD		JUN. 2016	
drawn	dessiné	scale	échelle
CD		AS NOTED	
checked	vérifié	sheet	feuille
MM		- of/de -	
approved	approuvé	W.O.no.	D.T.no.
XX		----	
dwg.no.	dessin no.		

1 A102 REFLECTED CEILING PLAN
SCALE 1 : 100

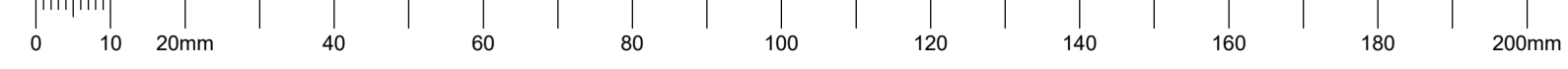

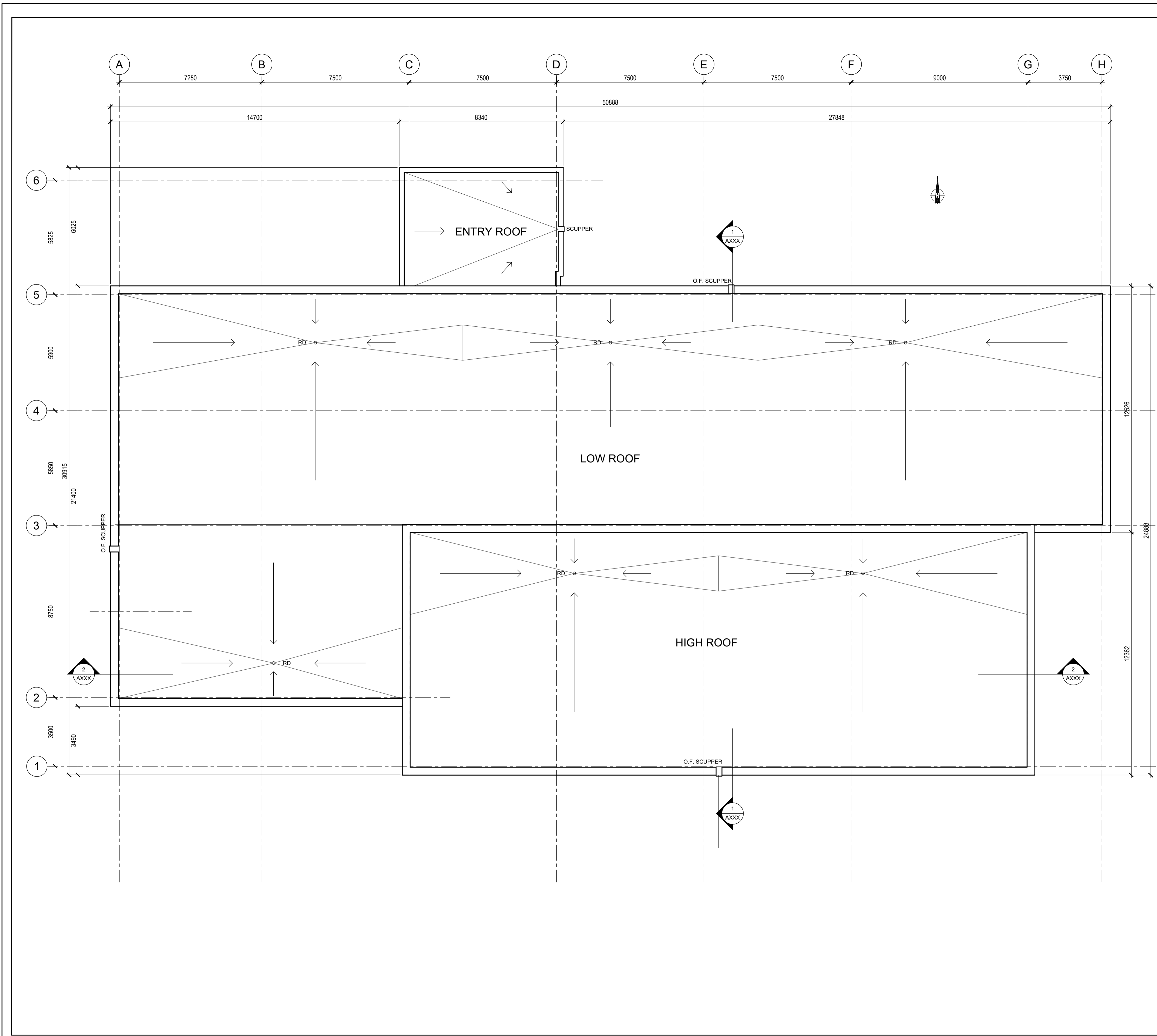

GENERAL NOTES
 PRIOR TO COMMENCEMENT OF WORK, NOTIFY DEPARTMENTAL REPRESENTATIVE OF ANY DISCREPANCIES NOTED IN THE CONTRACT DOCUMENTS.
 A. ALL GRID TO GRID DIMENSIONS ARE PLUS/MINUS. PRIOR TO COMMENCEMENT OF WORK, REVIEW SITE CONDITIONS AND VERIFY ALL DIMENSIONS. NOTIFY DEPARTMENTAL REPRESENTATIVE OF ANY DISCREPANCIES.
 B. DO NOT SCALE DRAWINGS.
 C. ALL DIMENSIONS ARE INDICATED IN MILLIMETERS UNLESS OTHERWISE SPECIFIED.

DRAWING NOTES - SHEET A100
 THESE NOTES APPLY TO DRAWING SHEET A100 ONLY
 01 XXXXXXX.
 02 XXXXXXX.

- GENERAL NOTES**
- CONTRACTORS TO CHECK AND VERIFY ALL DIMENSIONS ON SITE PRIOR TO DEMOLITION OR CONSTRUCTION AND REPORT ANY ERRORS OR OMISSIONS TO DEPARTMENTAL REPRESENTATIVE.
 - CONTRACTORS MUST VISIT THE SITE & FULLY FAMILIARIZE THEMSELVES WITH THE SCOPE OF THE WORK.
 - PREVENT THE SPREAD OF DUST & DEBRIS BEYOND THE WORK AREA AND CLEAN ALL SURFACES AT COMPLETION.
 - MAKE GOOD ALL SURFACES AFFECTED BY THIS WORK.
 - COORDINATE ALL SHUTDOWNS WITH THE DEPARTMENTAL REPRESENTATIVE.
 - PROVIDE ALL LABOUR AND MATERIAL REQUIRED TO FORM A COMPLETE, FUNCTIONAL SYSTEM AS DESCRIBED ON DRAWINGS.

1	JUNE 15 2016	ISSUED FOR 50% REVIEW	KWC
No.	Date	Revision	By: / Par:
Date Printed		Date imprimée	

kwc
 383 Parkdale Avenue, Suite 201
 Ottawa Ontario Canada K1Y 4R4
KWC ARCHITECTS INC.
 PHONE: (613) 238-2117
 FAX: (613) 238-6595
 E MAIL: kwc@kwc-arch.com

- Verify all dimensions and site conditions and be responsible for same
- Vérifier toutes les dimensions et l'état des lieux et en assumer la responsabilité

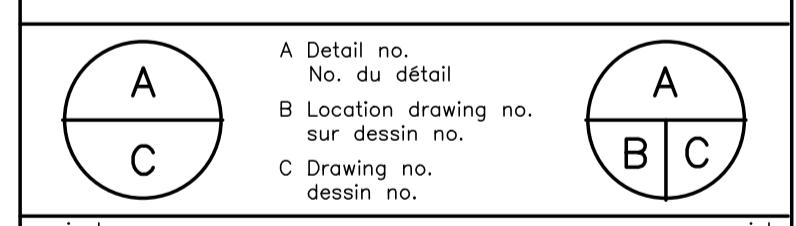

project / projet
NRC U72 FLIGHT RESEARCH FACILITY UPLANDS CAMPUS
 OTTAWA, ON
 drawing / dessin
ROOF PLAN

designed / conçu	date	date
MM/CD	JUN. 2016	
drawn / dessiné	scale / échelle	
CD	AS NOTED	
checked / vérifié	sheet / feuille	of / de
MM	-	-
approved / approuvé	W.O.no.	D.T.no.
XX	----	----
dwg.no.	dessin no.	

1
A103
ROOF PLAN
 SCALE 1 : 100

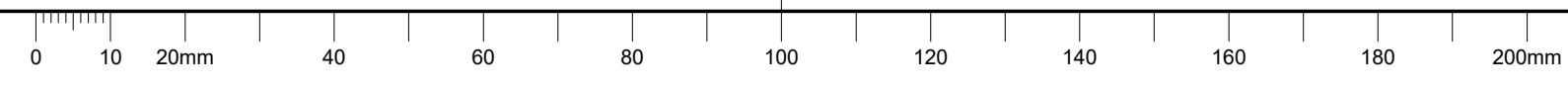

C

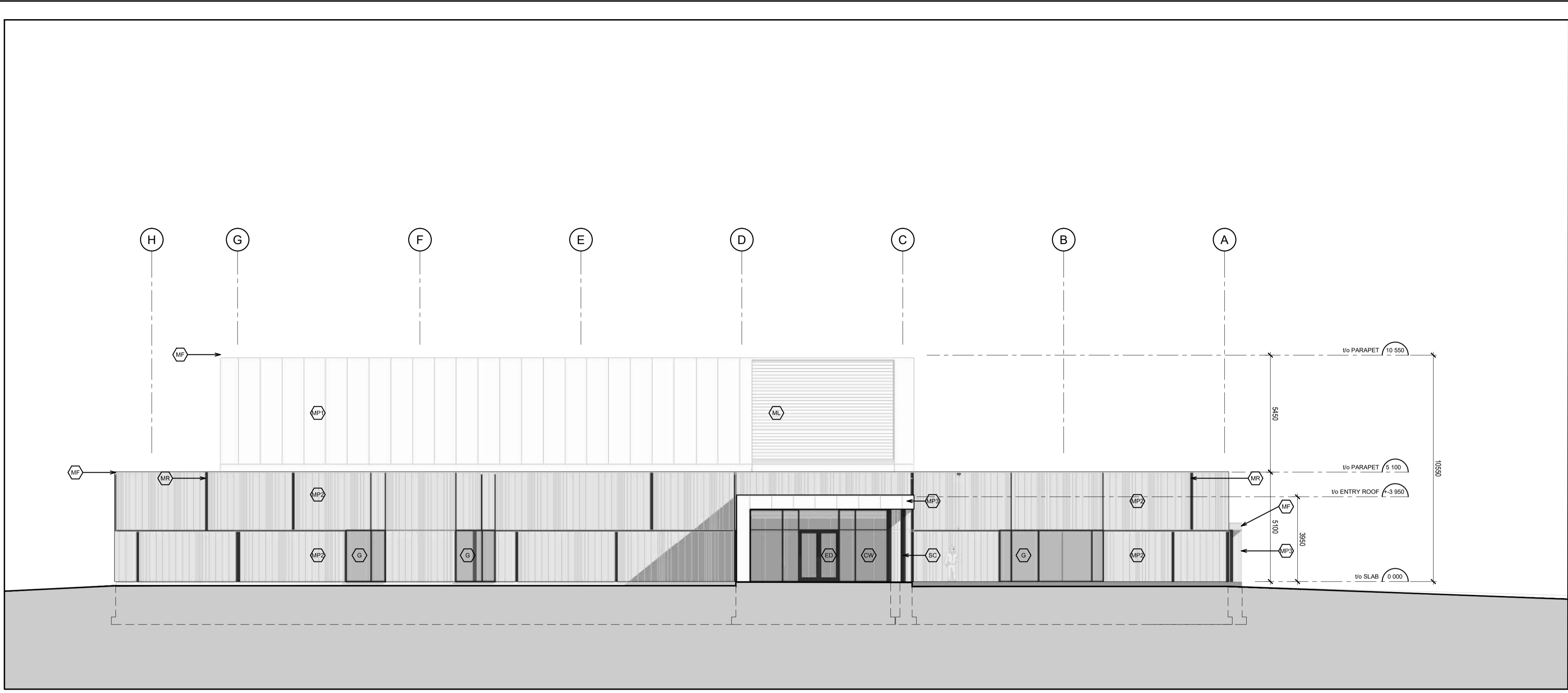

1 NORTH ELEVATION
SCALE 1 : 125

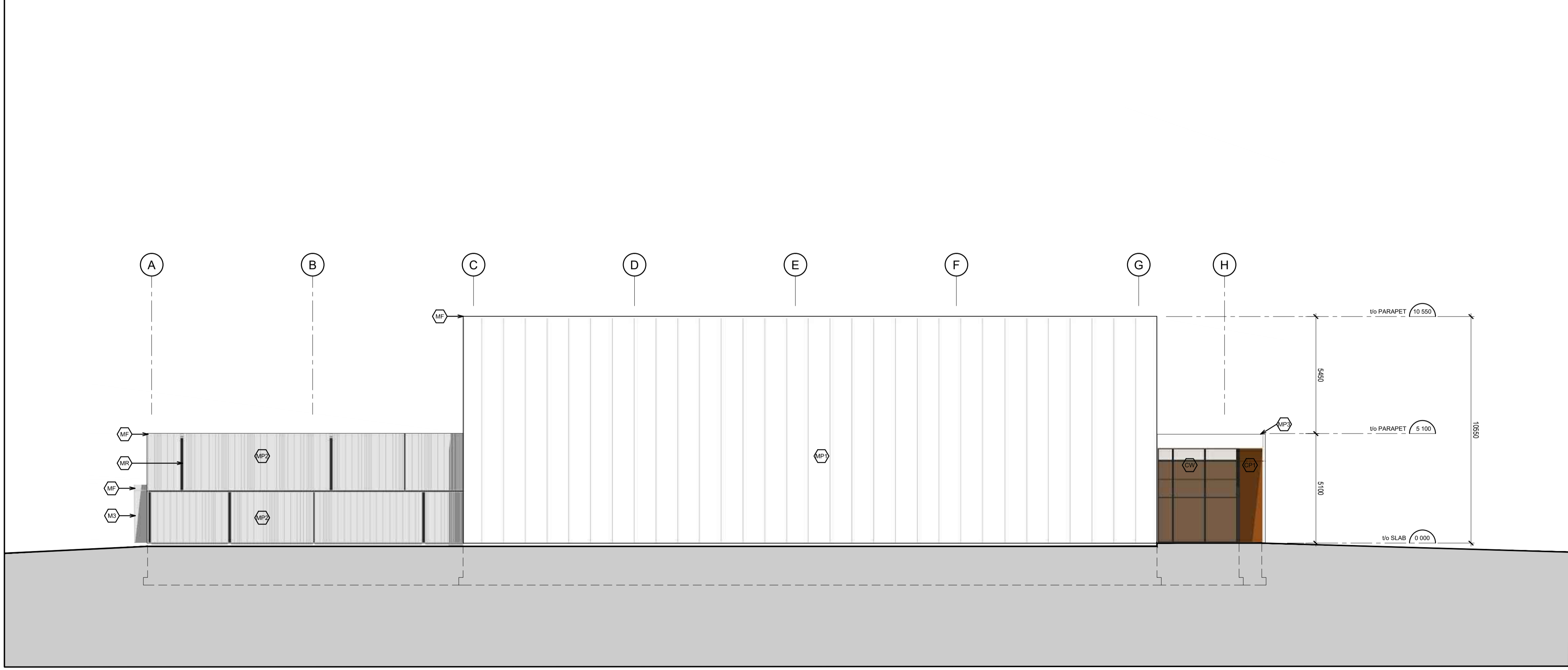

2 SOUTH ELEVATION
SCALE 1 : 125

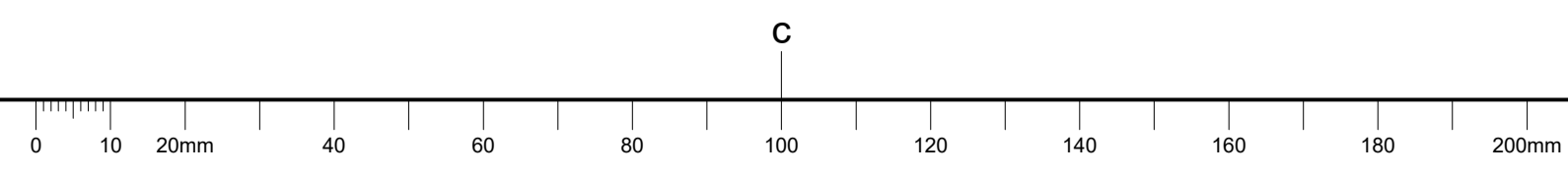

GENERAL NOTES
 PRIOR TO COMMENCEMENT OF WORK, NOTIFY DEPARTMENTAL REPRESENTATIVE OF ANY DISCREPANCIES NOTED IN THE CONTRACT DOCUMENTS.
 A. ALL GRID TO GRID DIMENSIONS ARE PLUS/MINUS. PRIOR TO COMMENCEMENT OF WORK, REVIEW SITE CONDITIONS AND VERIFY ALL DIMENSIONS. NOTIFY DEPARTMENTAL REPRESENTATIVE OF ANY DISCREPANCIES.
 B. DO NOT SCALE DRAWINGS.
 C. ALL DIMENSIONS ARE INDICATED IN MILLIMETERS UNLESS OTHERWISE SPECIFIED.

DRAWING NOTES - SHEET A200/A201
 THESE NOTES APPLY TO DRAWING SHEET A201 ONLY
 01 XXXXXXX.
 02 XXXXXXX.

LEGEND - SHEET A200/A201

- (MP1) METAL PANEL - TYPE 1
- (MP2) METAL PANEL - TYPE 2
- (MP3) METAL PANEL - TYPE 3
- (CP1) COMPOSITE PANEL - TYPE 4
- (CW) CURTAIN WALL
- (G) GLAZING
- (CG) CLERESTORY GLAZING
- (MF) PRE-FINISHED METAL FLASHING
- (OD) OVERHEAD ROLL UP DOOR
- (ED) ENTRANCE/EXIT DOOR
- (SD) SERVICE DOOR
- (SC) PAINTED STEEL COLUMN
- (ML) PREFINISHED METAL LOUVER
- (MR) PREFINISHED METAL REVEAL



GENERAL NOTES

- CONTRACTORS TO CHECK AND VERIFY ALL DIMENSIONS ON SITE PRIOR TO DEMOLITION OR CONSTRUCTION AND REPORT ANY ERRORS OR OMISSIONS TO DEPARTMENTAL REPRESENTATIVE.
- CONTRACTORS MUST VISIT THE SITE & FULLY FAMILIARIZE THEMSELVES WITH THE SCOPE OF THE WORK.
- PREVENT THE SPREAD OF DUST & DEBRIS BEYOND THE WORK AREA AND CLEAN ALL SURFACES AT COMPLETION.
- MAKE GOOD ALL SURFACES AFFECTED BY THIS WORK.
- COORDINATE ALL SHUTDOWNS WITH THE DEPARTMENTAL REPRESENTATIVE.
- PROVIDE ALL LABOUR AND MATERIAL REQUIRED TO FORM A COMPLETE, FUNCTIONAL SYSTEM AS DESCRIBED ON DRAWINGS.

No.	Date	Revision	By:	For:
1	JUN 2016	50% CLIENT REVIEW	KWC	

kwc
 383 Parkdale Avenue, Suite 201
 Ottawa Ontario Canada K1Y 4R4
KWC ARCHITECTS INC.
 PHONE: (613) 238-2117
 FAX: (613) 238-6595
 E MAIL: kwc@kwc-arch.com

- Verify all dimensions and site conditions and be responsible for same
- Vérifier toutes les dimensions et l'état des lieux et en assumer la responsabilité

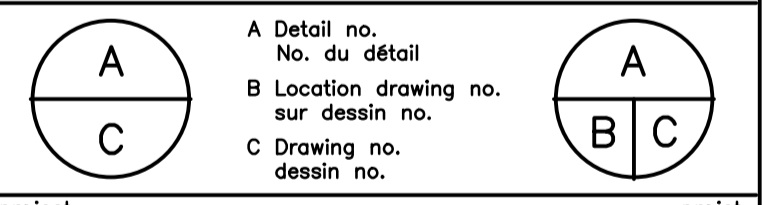

project: **NRC U72 FLIGHT RESEARCH FACILITY UPLANDS CAMPUS**

drawing: **OTTAWA, ON BUILDING ELEVATIONS NORTH and SOUTH**

designed	conçu	date	date
MM/CD		JUN, 2016	
drawn	dessiné	scale	échelle
CD		AS NOTED	
checked	vérifié	sheet	feuille
MM		- of/de -	
approved	approuvé	W.O.no.	D.T.no.
XX		----	

dwg.no. A200 dessin no.

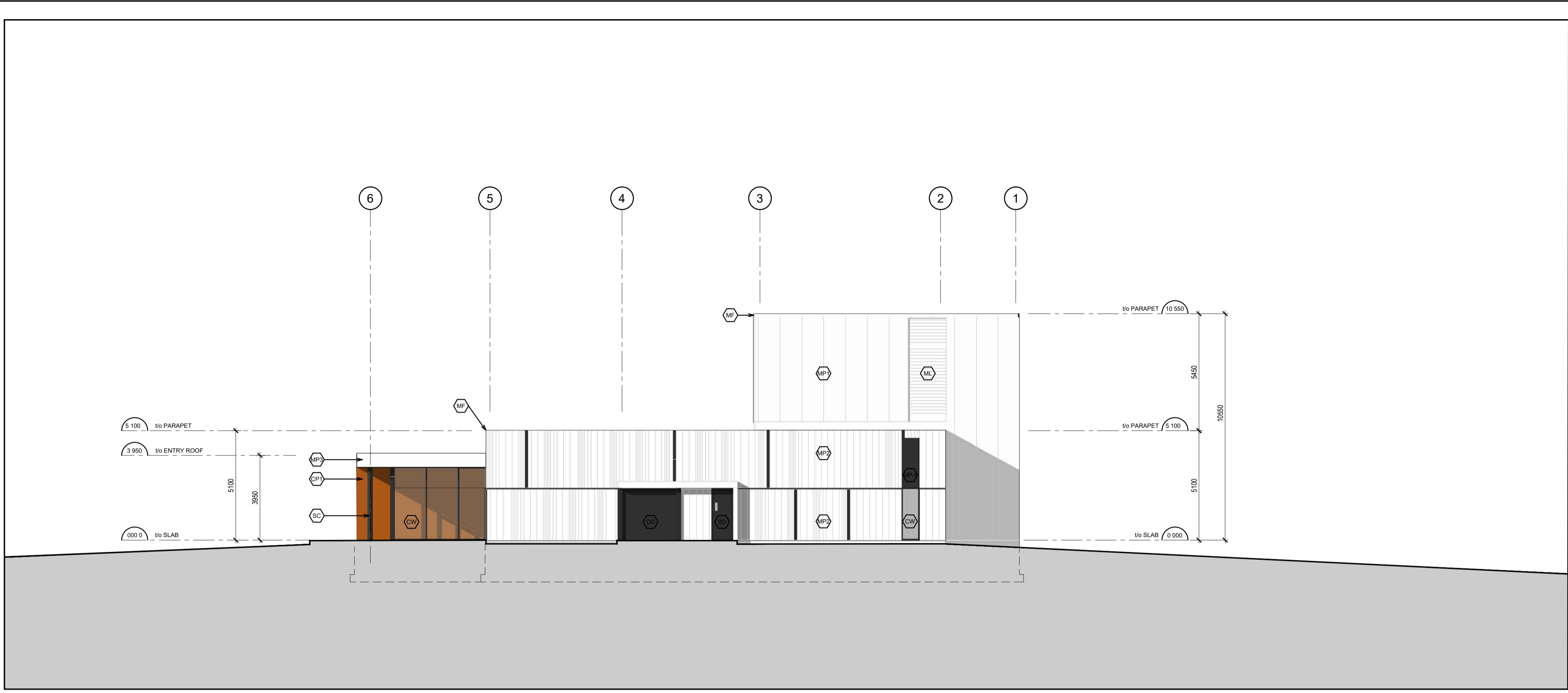

1
A201
EAST ELEVATION
SCALE 1 : 125

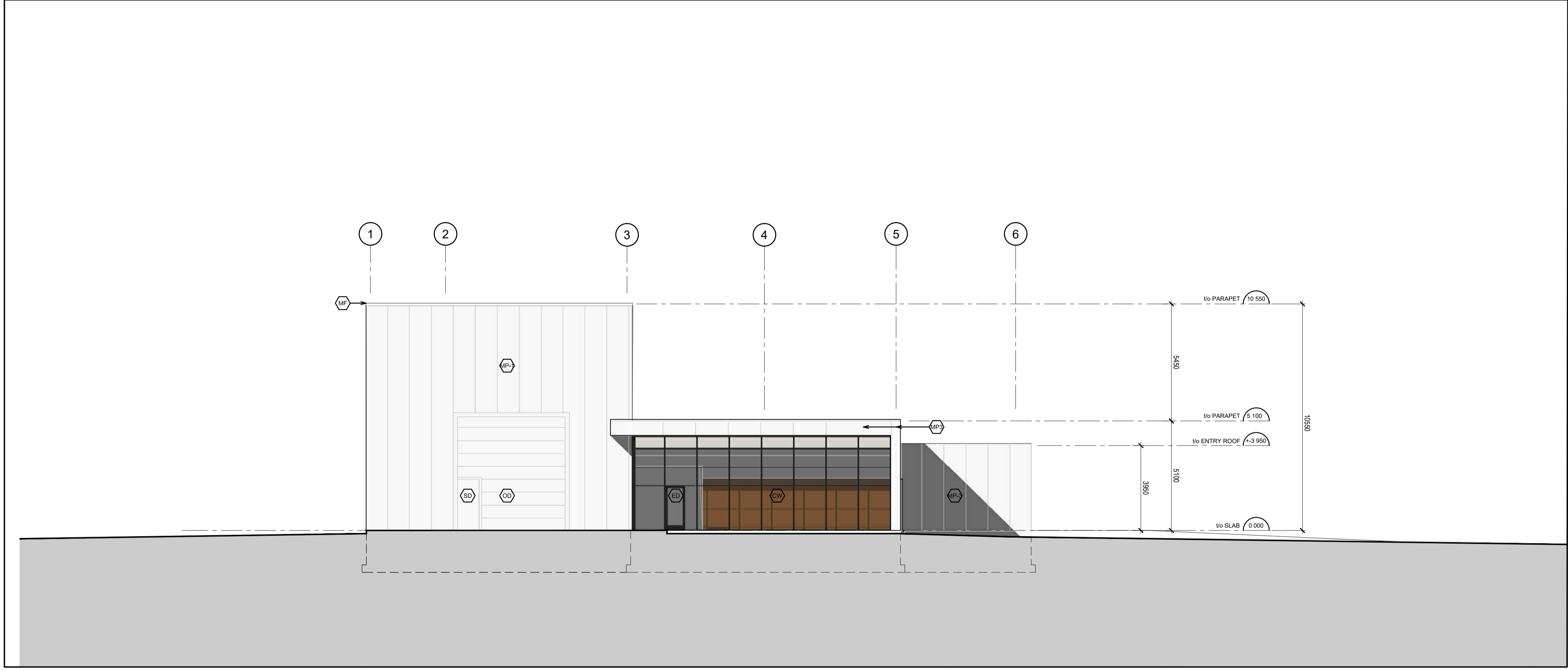

2
A201
WEST ELEVATION
SCALE 1 : 125

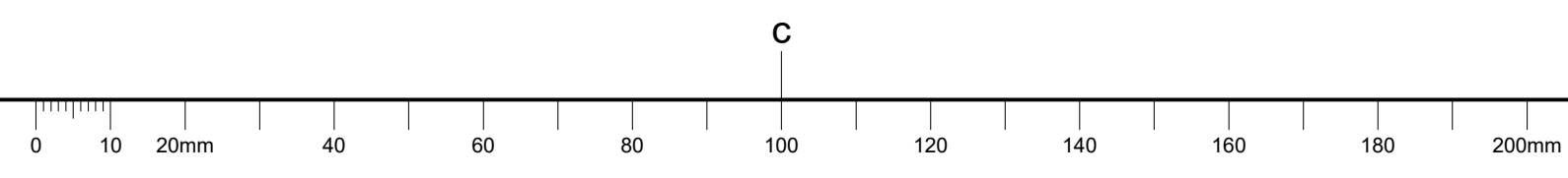

GENERAL NOTES
PRIOR TO COMMENCEMENT OF WORK, NOTIFY DEPARTMENTAL REPRESENTATIVE OF ANY DISCREPANCIES NOTED IN THE CONTRACT DOCUMENTS.
A. ALL GRID TO GRID DIMENSIONS ARE PLUS/MINUS. PRIOR TO COMMENCEMENT OF WORK, REVIEW SITE CONDITIONS AND VERIFY ALL DIMENSIONS. NOTIFY DEPARTMENTAL REPRESENTATIVE OF ANY DISCREPANCIES.
B. DO NOT SCALE DRAWINGS.
C. ALL DIMENSIONS ARE INDICATED IN MILLIMETERS UNLESS OTHERWISE SPECIFIED.

DRAWING NOTES - SHEET A200/A201
THESE NOTES APPLY TO DRAWING SHEET A201 ONLY
01 XXXXXXXX.
02 XXXXXXXX.

- LEGEND - SHEET A200/A201**
- (MP1) METAL PANEL - TYPE 1
 - (MP2) METAL PANEL - TYPE 2
 - (MP3) METAL PANEL - TYPE 3
 - (CP1) COMPOSITE PANEL - TYPE 4
 - (CW) CURTAIN WALL
 - (G) GLAZING
 - (CG) CLERESTORY GLAZING
 - (MF) PRE-FINISHED METAL FLASHING
 - (OD) OVERHEAD ROLL UP DOOR
 - (ED) ENTRANCE/EXIT DOOR
 - (SD) SERVICE DOOR
 - (SC) PAINTED STEEL COLUMN
 - (ML) PREFINISHED METAL LOUVER
 - (MR) PREFINISHED METAL REVEAL



GENERAL NOTES

- CONTRACTORS TO CHECK AND VERIFY ALL DIMENSIONS ON SITE PRIOR TO DEMOLITION OR CONSTRUCTION AND REPORT ANY ERRORS OR OMISSIONS TO DEPARTMENTAL REPRESENTATIVE.
- CONTRACTORS MUST VISIT THE SITE & FULLY FAMILIARIZE THEMSELVES WITH THE SCOPE OF THE WORK.
- PREVENT THE SPREAD OF DUST & DEBRIS BEYOND THE WORK AREA AND CLEAN ALL SURFACES AT COMPLETION.
- MAKE GOOD ALL SURFACES AFFECTED BY THIS WORK.
- COORDINATE ALL SHUTDOWNS WITH THE DEPARTMENTAL REPRESENTATIVE.
- PROVIDE ALL LABOUR AND MATERIAL REQUIRED TO FORM A COMPLETE, FUNCTIONAL SYSTEM AS DESCRIBED ON DRAWINGS.

No.	Date	Revision	By:	Par:
1	JUN 2016	50% CLIENT REVIEW	KWC	

kwc
383 Parkdale Avenue, Suite 201
Ottawa Ontario Canada K1Y 4R4
KWC ARCHITECTS INC.
PHONE (613) 238-2117
FAX (613) 238-6595
E MAIL kwc@kwc-arch.com

- Verify all dimensions and site conditions and be responsible for same
- Vérifier toutes les dimensions et l'état des lieux et en assumer la responsabilité

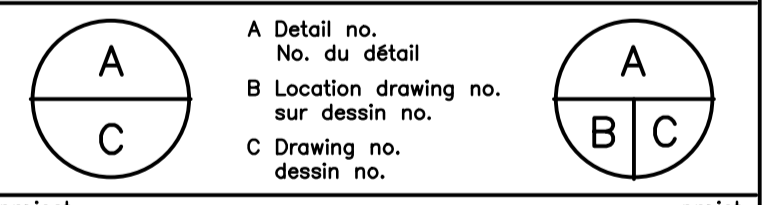

project **NRC U72 FLIGHT RESEARCH FACILITY UPLANDS CAMPUS** project
drawing **OTTAWA, ON** dessin
BUILDING ELEVATIONS EAST and WEST

designed	conçu	date	date
MM/CD		JUN, 2016	
drawn	dessiné	scale	échelle
CD		AS NOTED	
checked	vérifié	sheet	feuille
MM		- of/de -	
approved	approuvé	W.O.no.	D.T.no.
XX		----	

dwg.no. **A201** dessin.no.

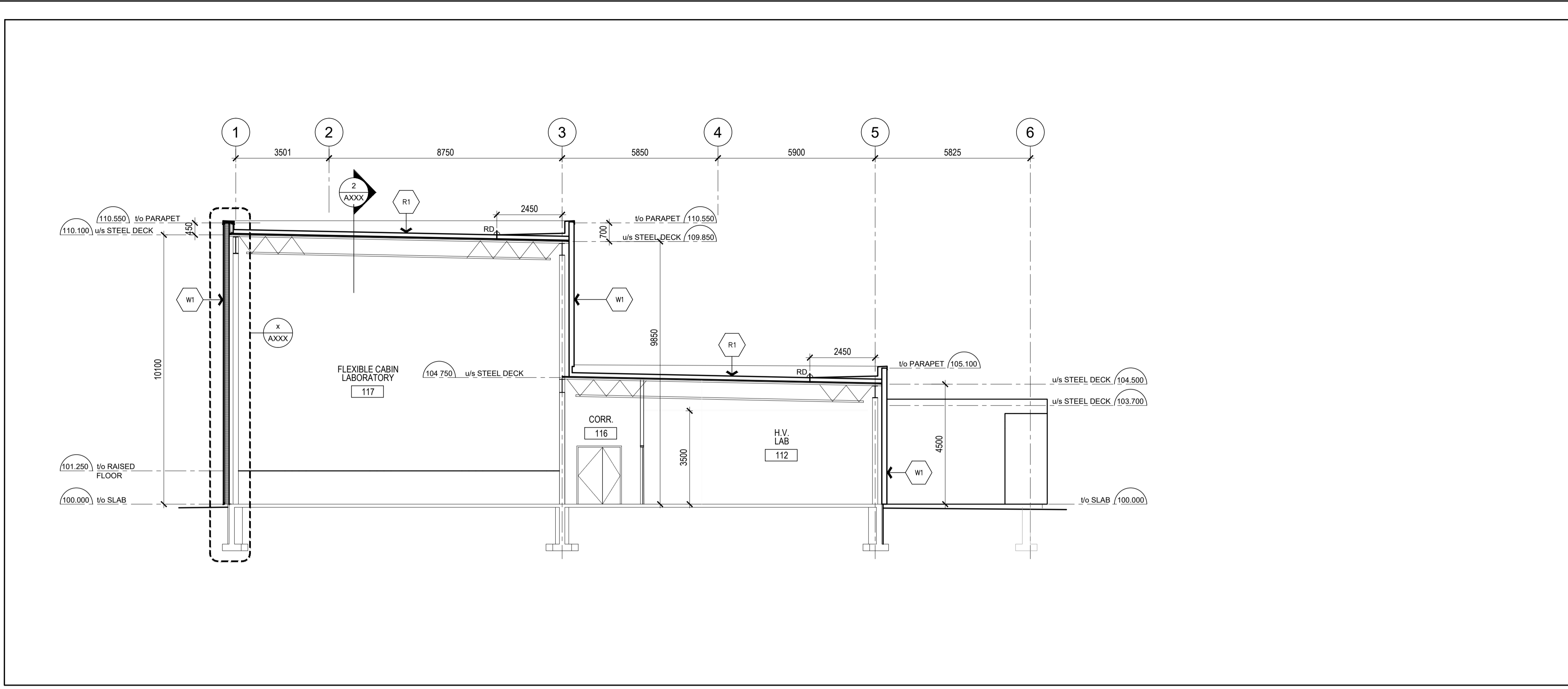

1
A300
CROSS SECTION
SCALE 1 : 100

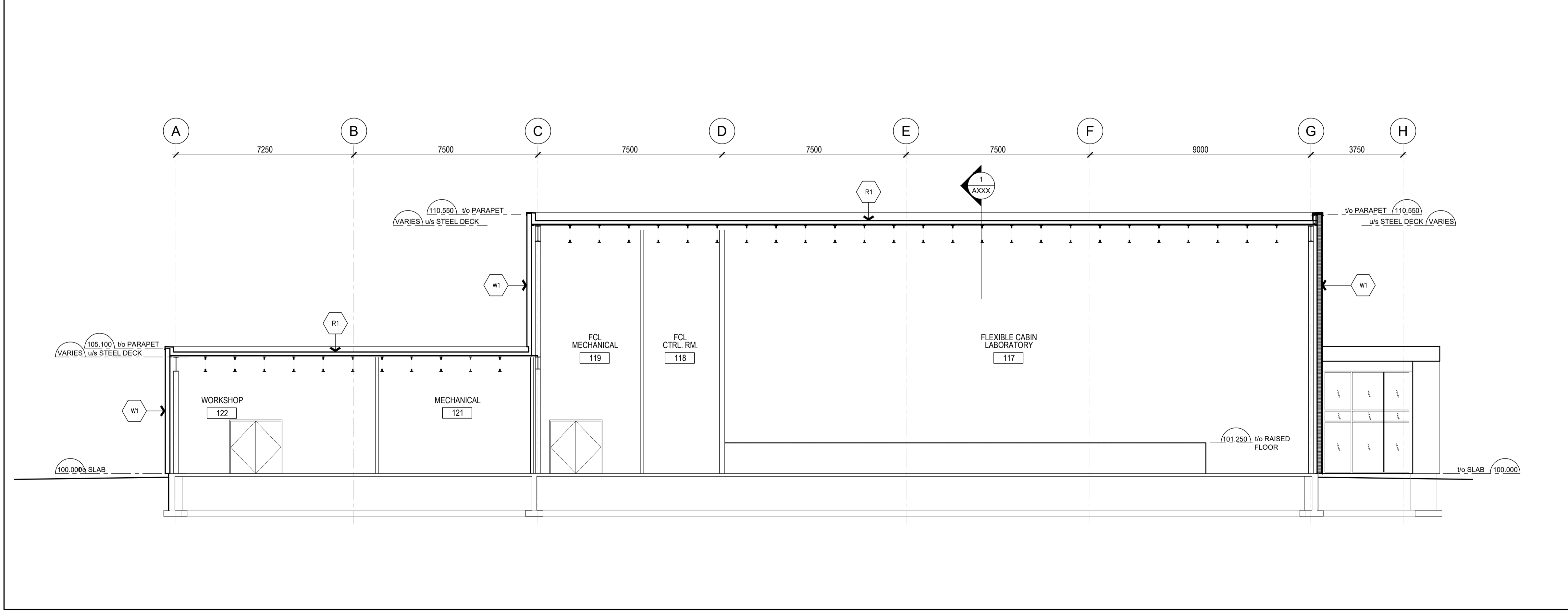

2
A300
LONGITUDINAL SECTION
SCALE 1 : 100

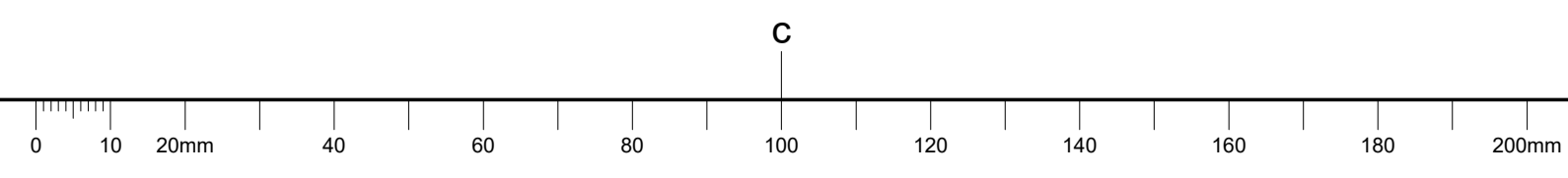

GENERAL NOTES
PRIOR TO COMMENCEMENT OF WORK, NOTIFY DEPARTMENTAL REPRESENTATIVE OF ANY DISCREPANCIES NOTED IN THE CONTRACT DOCUMENTS.
A. ALL GRID TO GRID DIMENSIONS ARE PLUS/MINUS. PRIOR TO COMMENCEMENT OF WORK, REVIEW SITE CONDITIONS AND VERIFY ALL DIMENSIONS. NOTIFY DEPARTMENTAL REPRESENTATIVE OF ANY DISCREPANCIES.
B. DO NOT SCALE DRAWINGS.
C. ALL DIMENSIONS ARE INDICATED IN MILLIMETERS UNLESS OTHERWISE SPECIFIED.

DRAWING NOTES - SHEET A300
THESE NOTES APPLY TO DRAWING SHEET A300 ONLY.
01 XXXXXXX.
02 XXXXXXX.



GENERAL NOTES

- CONTRACTORS TO CHECK AND VERIFY ALL DIMENSIONS ON SITE PRIOR TO DEMOLITION OR CONSTRUCTION AND REPORT ANY ERRORS OR OMISSIONS TO DEPARTMENTAL REPRESENTATIVE.
- CONTRACTORS MUST VISIT THE SITE & FULLY FAMILIARIZE THEMSELVES WITH THE SCOPE OF THE WORK.
- PREVENT THE SPREAD OF DUST & DEBRIS BEYOND THE WORK AREA AND CLEAN ALL SURFACES AT COMPLETION.
- MAKE GOOD ALL SURFACES AFFECTED BY THIS WORK.
- COORDINATE ALL SHUTDOWNS WITH THE DEPARTMENTAL REPRESENTATIVE.
- PROVIDE ALL LABOUR AND MATERIAL REQUIRED TO FORM A COMPLETE, FUNCTIONAL SYSTEM AS DESCRIBED ON DRAWINGS.

1	JUNE 15 2016	ISSUED FOR 50% REVIEW	KWC
No.	Date	Revision	By: For:
Date Printed		Date imprimée	

kwc
383 Parkdale Avenue, Suite 201
Ottawa Ontario Canada K1Y 4R4
KWC ARCHITECTS INC.
PHONE: (613) 238-2117
FAX: (613) 238-6595
E MAIL: kwc@kwc-arch.com

- Verify all dimensions and site conditions and be responsible for same
- Vérifier toutes les dimensions et l'état des lieux et en assumer la responsabilité

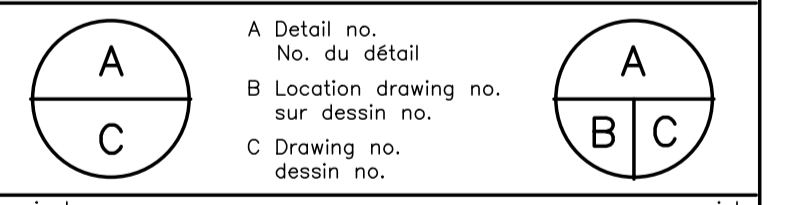

project
**NRC U72 FLIGHT RESEARCH FACILITY
UPLANDS CAMPUS**

OTTAWA, ON
drawing

BUILDING SECTIONS

designed	conçu	date	date
CD/MM		JUNE, 2016	
drawn	dessiné	scale	échelle
CD/MM		1:100	
checked	vérifié	sheet	feuille
MM		- of/de -	
approved	approuvé	W.O.no.	D.T.no.
MM		----	
dwg.no.		dessin no.	

A300

NRC UPLANDS CAMPUS

BUILDING U72

ELECTRICAL



GENERAL NOTES

- CONTRACTORS TO CHECK AND VERIFY ALL DIMENSIONS ON SITE PRIOR TO DEMOLITION OR CONSTRUCTION AND REPORT ANY ERRORS OR OMISSIONS TO DEPARTMENTAL REPRESENTATIVE.
- CONTRACTORS MUST VISIT THE SITE & FULLY FAMILIARIZE THEMSELVES WITH THE SCOPE OF THE WORK.
- PREVENT THE SPREAD OF DUST & DEBRIS BEYOND THE WORK AREA AND CLEAN ALL SURFACES AT COMPLETION.
- MAKE GOOD ALL SURFACES AFFECTED BY THIS WORK.
- COORDINATE ALL SHUTDOWNS WITH THE DEPARTMENTAL REPRESENTATIVE.
- PROVIDE ALL LABOUR AND MATERIAL REQUIRED TO FORM A COMPLETE, FUNCTIONAL SYSTEM AS DESCRIBED ON DRAWINGS.

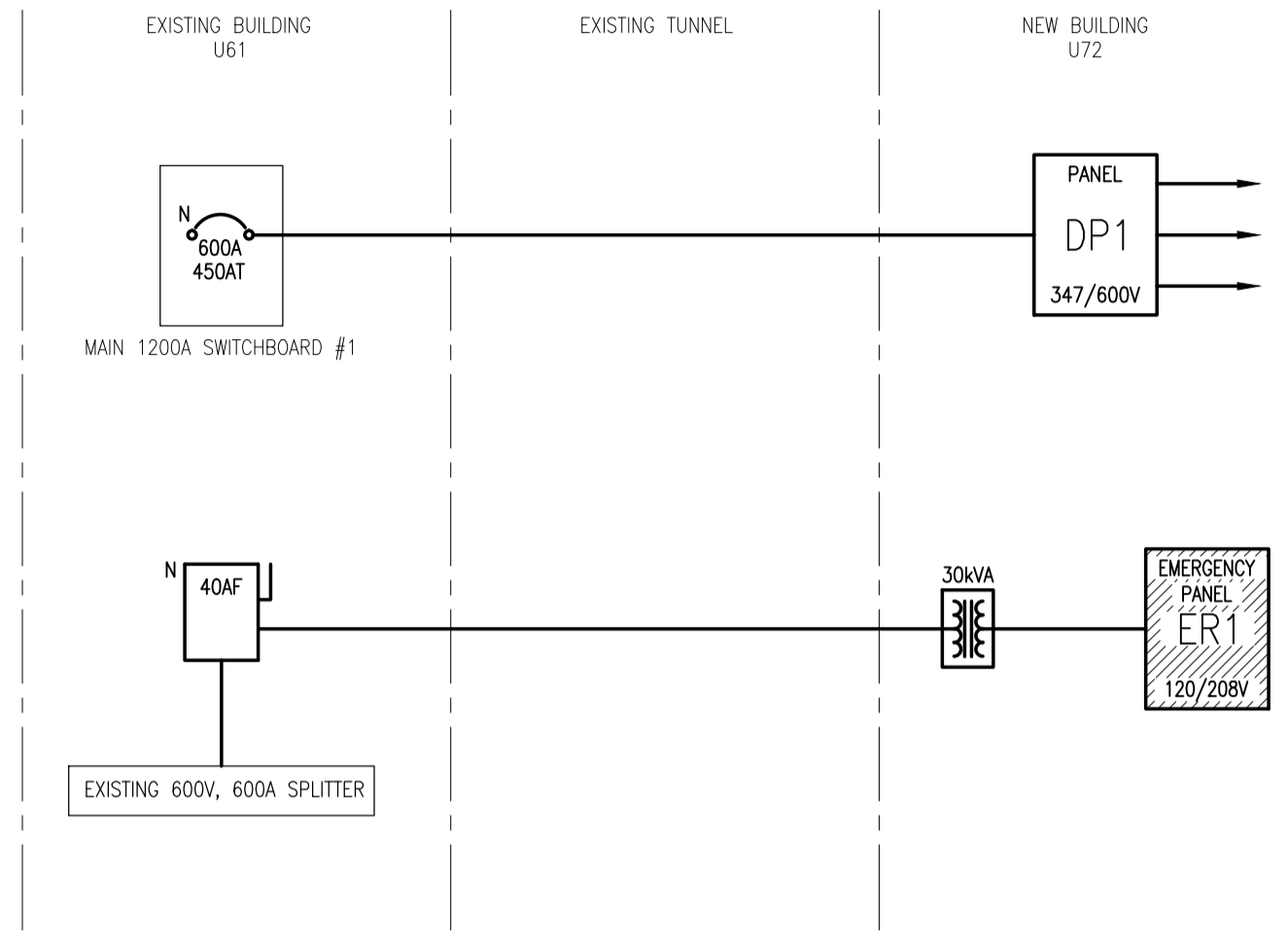

1 PARTIAL ELECTRICAL SINGLE LINE DIAGRAM
E1 N.T.S.

DRAWING LIST	
DWG No.	DESCRIPTION
E1	ELECTRICAL LEGENDS, DRAWING LIST AND PANEL SCHEDULES
E2	5TH FLOOR LIGHTING AND FIRE ALARM DEMOLITION WORK
E3	5TH FLOOR LIGHTING AND FIRE ALARM NEW WORK
E4	5TH FLOOR POWER AND SYSTEMS DEMOLITION WORK
E5	5TH FLOOR POWER AND SYSTEMS NEW WORK

LINETYPE LEGEND	
SYMBOL	DESCRIPTION
—	NEW WORK
---	EXISTING
---	ARCHITECTURAL GRID LINES
.....	CEILING GRID

ABBREVIATION LEGEND	
SYMBOL	DESCRIPTION
C	CEILING MOUNTED
GFI	GROUND FAULT INTERRUPTER
OC	INSTALLED OVER COUNTER TOP
F	FLOOR MOUNTED
S	SURFACE MOUNTED
N	NEW
WP	WEATHERPROOF

ELECTRICAL LEGEND	
SYMBOL	DESCRIPTION
	LED CEILING MOUNTED LIGHT FIXTURE
	LIGHT FIXTURE CONNECTED TO UNSWITCHED EMERGENCY CIRCUIT
	RECESSED DOWN LIGHT FIXTURE, TYPE AS INDICATED
	RECESSED DOWN LIGHT FIXTURE, UNSWITCHED EMERGENCY CIRCUIT
	WALL MOUNTED LIGHT SWITCH
	DIMMER LIGHT SWITCH
	WALL MOUNTED OCCUPANCY SENSOR SWITCH
	CEILING OCCUPANCY SENSOR
	EMERGENCY LIGHTING CONTROL UNIT
	CEILING MOUNTED EXIT LIGHT WITH DIRECTIONAL ARROWS AS INDICATED
	WALL MOUNTED EXIT LIGHT WITH DIRECTIONAL ARROWS AS INDICATED
	FIRE ALARM SPEAKER
	FIRE ALARM COMBINATION SPEAKER/STROBE
	FIRE ALARM SMOKE DETECTOR
	FIRE ALARM HANDSET
	MAGNETIC LOCK
	FIRE ALARM PULL STATION
	15A, 120V WALL MOUNTED DUPLEX RECEPTACLE
	15A, 120V DEDICATED DUPLEX RECEPTACLE
	15A, 120V DUPLEX RECEPTACLE - INSTALLED OVER COUNTER
	20A, 120V, RA RECEPTACLE - INSTALLED OVER COUNTER
	20A, 120V, RA RECEPTACLE
	15A, 120V HALF SWITCH RECEPTACLE
	FURNITURE POLE
	SERVICE POLE
	FLOOR MONUMENT
	JUNCTION BOX
	FLEXIBLE CONDUIT CONNECTION
	MANUAL MOTOR STARTER - CSA CERTIFIED AS A DISCONNECTING MEANS AND LOCKABLE IN THE "OFF" POSITION.
	SINGLE PHASE ELECTRIC MOTOR
	SPEED SWITCH
	DISCONNECT SWITCH
	ON/OFF SWITCH C/W PILOT LIGHT
	SURFACE MOUNTED ELECTRICAL PANEL
	RECESS MOUNTED ELECTRICAL PANEL
	EMERGENCY PULL STATION
	BASEBOARD HEATER C/W INTEGRAL THERMOSTAT
	VOICE AND/OR DATA OUTLET BOX
	CABLEVISION OUTLET
	MICROPHONE OUTLET
	REQUEST TO EXIT (PROVIDED BY SECURITY CONTRACTOR C/W WIRING)
	CARD READER (PROVIDED BY SECURITY CONTRACTOR C/W WIRING)
	ELECTRIC STRIKE (PROVIDED BY SECURITY CONTRACTOR C/W WIRING)
	DOOR CONTACT (PROVIDED BY SECURITY CONTRACTOR C/W WIRING)
	MOTION SENSOR (PROVIDED BY SECURITY CONTRACTOR C/W WIRING)
	DOOR BELL CHIME
	DOOR BELL PUSHBUTTON
	BARRIER-FREE DOOR OPERATOR C/W PUSHBUTTONS

2016-05-15	ISSUED FOR 50% REVIEW	
DATE	REVISION	REF

Goodkey Weedmark
 Consulting Engineers

GOODKEY WEEDMARK □ ASSOCIATES LIMITED
 1688 Woodward Dr. Ottawa Ontario Canada K2C 3R8
 613 727-5111 (113) 238-6595
 613 727-5115 Fax
 www.gwal.com Web
 2016-236 Job □

kwc
 ARCHITECTS INC.

383 Parkdale Avenue, Suite 201
 Ottawa Ontario Canada K1Y 4R4
 PHONE (613) 238-2117
 FAX (613) 238-6595
 E MAIL kwc@kwc-arch.com

- o Verify all dimensions and site conditions and be responsible for same
- o Vérifier toutes les dimensions et l'état des lieux et en assumer la responsabilité

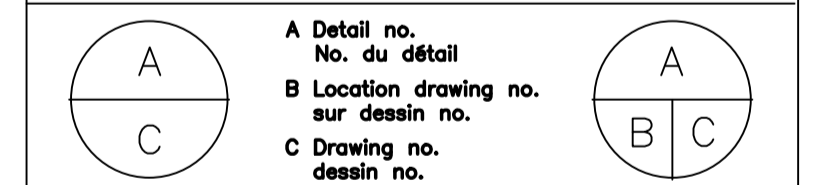

project		dessin	
U72 - FLEXIBLE CABIN LABORATORY			
NRC UPLANDS CAMPUS			
OTTAWA, ON			
ELECTRICAL LEGENDS, DRAWING LIST AND PARTIAL SINGLE LINE			
designed	conçu	date	date
A.G.		Jun. 2016	
drawn	dessiné	scale	échelle
A.G.		AS NOTED	
checked	vérifié	sheet	feuille
R.B.		- of/de -	
approved	approuvé	W.O.no.	D.T.no.
R.B.			
dwg.no.			dessin no.
E1			

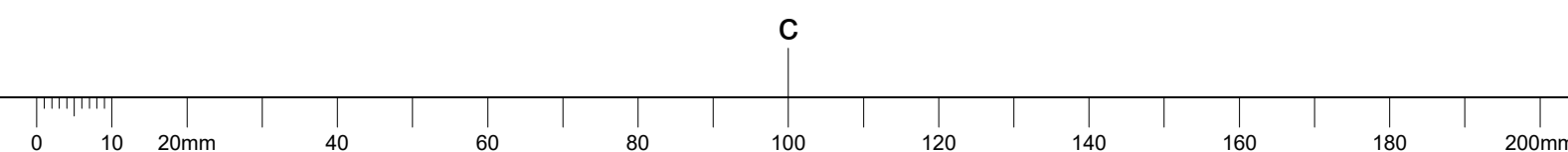

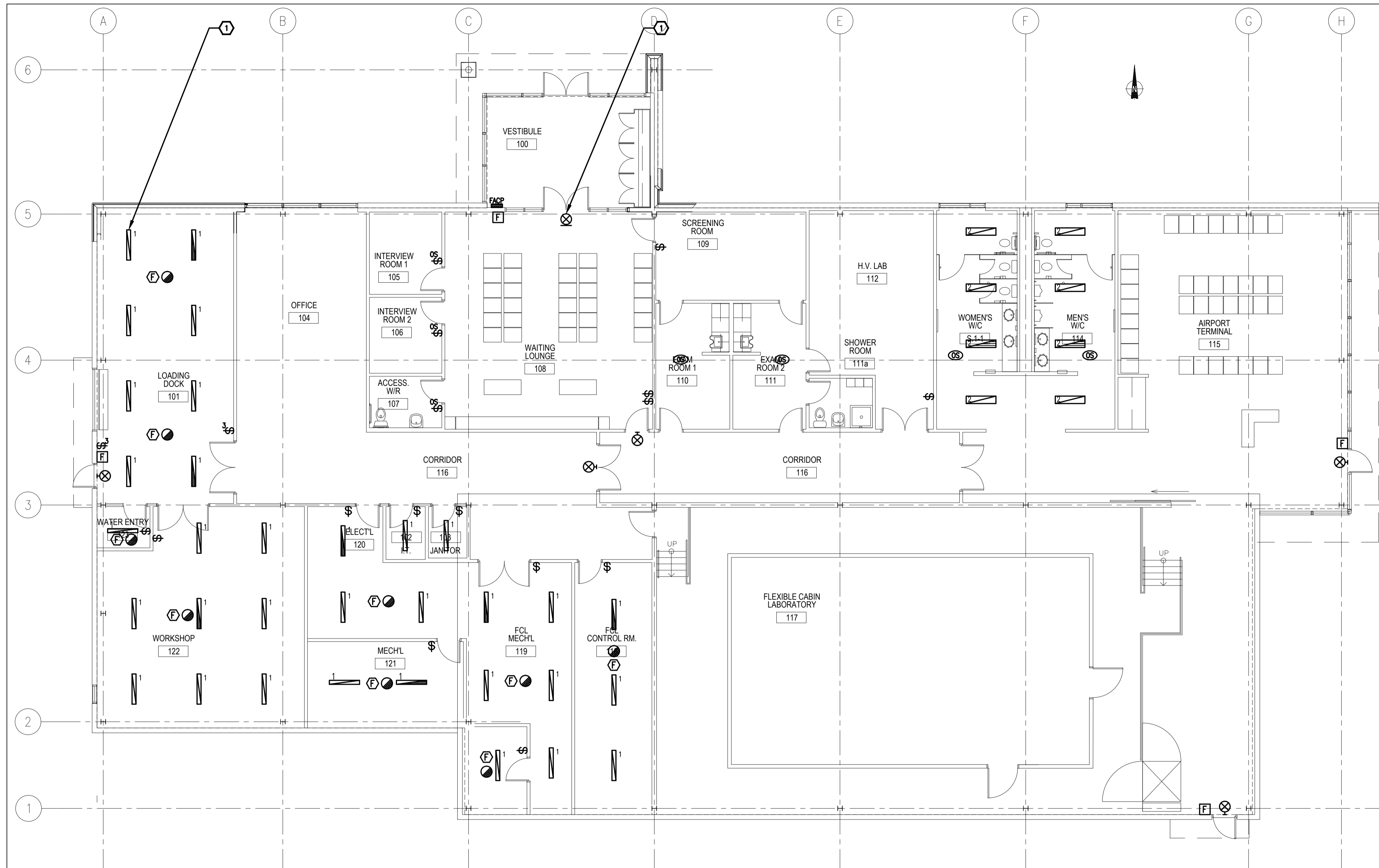

DRAWING NOTES

1 TYPICAL:
PROVIDE NEW LIGHT FIXTURE, TYPE AS INDICATED. REFERENCE LIGHT FIXTURE SCHEDULE ON DRAWING E1.

2 TYPICAL:
PROVIDE NEW WALL/CEILING MOUNTED PICTOGRAM "RUNNING MAN" EXIT SIGN AS INDICATED. CONNECT TO INDICATED CIRCUIT.



GENERAL NOTES

- CONTRACTORS TO CHECK AND VERIFY ALL DIMENSIONS ON SITE PRIOR TO DEMOLITION OR CONSTRUCTION AND REPORT ANY ERRORS OR OMISSIONS TO DEPARTMENTAL REPRESENTATIVE.
- CONTRACTORS MUST VISIT THE SITE & FULLY FAMILIARIZE THEMSELVES WITH THE SCOPE OF THE WORK.
- PREVENT THE SPREAD OF DUST & DEBRIS BEYOND THE WORK AREA AND CLEAN ALL SURFACES AT COMPLETION.
- MAKE GOOD ALL SURFACES AFFECTED BY THIS WORK.
- COORDINATE ALL SHUTDOWNS WITH THE DEPARTMENTAL REPRESENTATIVE.
- PROVIDE ALL LABOUR AND MATERIAL REQUIRED TO FORM A COMPLETE, FUNCTIONAL SYSTEM AS DESCRIBED ON DRAWINGS.

2016-05-15	ISSUED FOR 50% REVIEW	
DATE	REVISION	REF



GOODKEY WEEDMARK ASSOCIATES LIMITED
1688 Woodward Dr. Ottawa Ontario Canada K2C 3R8
613 727-5111 (Voice)
613 727-5115 (Fax)
www.gwal.com (Web)
2016-236 (Job #)

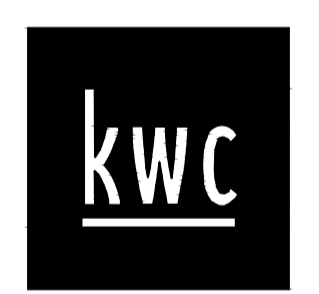

383 Parkdale Avenue, Suite 201
Ottawa Ontario Canada K1Y 4R4
KWC ARCHITECTS INC.
PHONE: (613) 238-2117
FAX: (613) 238-6595
E MAIL: kwc@kwc-arch.com

- Verify all dimensions and site conditions and be responsible for same
- Vérifier toutes les dimensions et l'état des lieux et en assumer la responsabilité

A	A Detail no. No. du détail	A
B	B Location drawing no. sur dessin no.	B
C	C Drawing no. dessin no.	C

project **U72 - FLEXIBLE CABIN LABORATORY** projet

NRC UPLANDS CAMPUS

OTTAWA, ON

drawing **LIGHTING AND FIRE ALARM NEW WORK** dessin

designed	conçu	date	date
A.G.		Jun. 2016	
drawn	dessiné	scale	échelle
A.G.		AS NOTED	
checked	vérifié	sheet	feuille
R.B.		- of/de -	
approved	approuvé	W.O.no.	D.T.no.
R.B.			
dwg.no.			dessin no.

E2

1 LIGHTING AND FIRE ALARM NEW WORK
E2 1:100

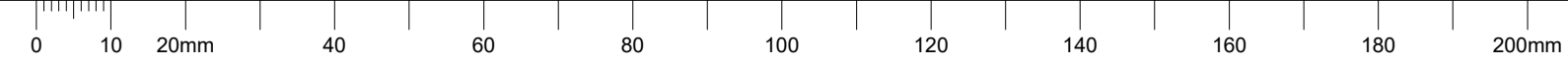

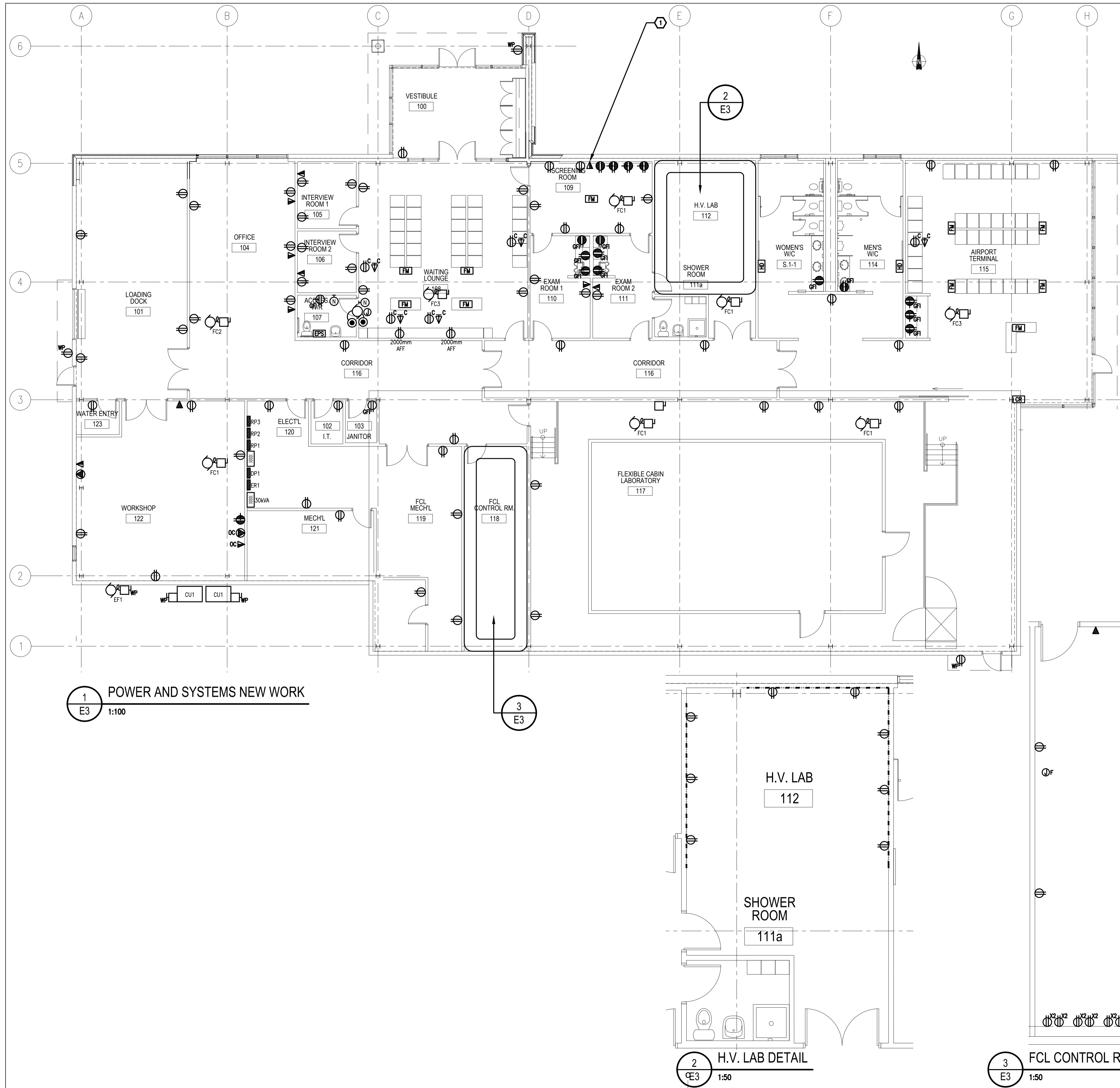

DRAWING NOTES

1 TYPICAL: PROVIDE BACK BOX C/W 21mm CONDUIT UP TO ACCESSIBLE CEILING SPACE FOR NEW DATA OUTLETS. DATA OUTLETS TO BE SUPPLIED AND INSTALLED BY OTHERS.

1 POWER AND SYSTEMS NEW WORK
E3 1:100

2 H.V. LAB DETAIL
E3 1:50

3 FCL CONTROL ROOM DETAIL
E3 1:50



GENERAL NOTES

- CONTRACTORS TO CHECK AND VERIFY ALL DIMENSIONS ON SITE PRIOR TO DEMOLITION OR CONSTRUCTION AND REPORT ANY ERRORS OR OMISSIONS TO DEPARTMENTAL REPRESENTATIVE.
- CONTRACTORS MUST VISIT THE SITE & FULLY FAMILIARIZE THEMSELVES WITH THE SCOPE OF THE WORK.
- PREVENT THE SPREAD OF DUST & DEBRIS BEYOND THE WORK AREA AND CLEAN ALL SURFACES AT COMPLETION.
- MAKE GOOD ALL SURFACES AFFECTED BY THIS WORK.
- COORDINATE ALL SHUTDOWNS WITH THE DEPARTMENTAL REPRESENTATIVE.
- PROVIDE ALL LABOUR AND MATERIAL REQUIRED TO FORM A COMPLETE, FUNCTIONAL SYSTEM AS DESCRIBED ON DRAWINGS.

2016-05-15	ISSUED FOR 50% REVIEW	
DATE	REVISION	REF



GOODKEY WEEDMARK ASSOCIATES LIMITED
1688 Woodward Dr. Ottawa Ontario Canada K2C 3R8
613 727-5111 / 613 727-5115 / 613 238-6595
Voice / Fax / Web
2016-236 Job#

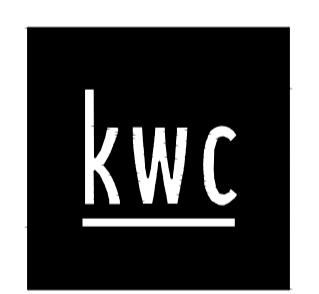

383 Parkdale Avenue, Suite 201
Ottawa Ontario Canada K1Y 4R4
KWC ARCHITECTS INC.
PHONE: (613) 238-2117
FAX: (613) 238-6595
E-MAIL: kwc@kwc-arch.com

- Verify all dimensions and site conditions and be responsible for same
- Vérifier toutes les dimensions et l'état des lieux et en assumer la responsabilité

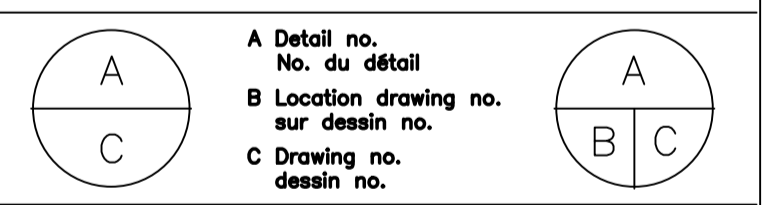

project		project	
U72 - FLEXIBLE CABIN LABORATORY			
NRC UPLANDS CAMPUS			
OTTAWA, ON			
drawing		dessin	
POWER AND SYSTEMS NEW WORK			
designed	conçu	date	date
A.G.		Jun. 2016	
drawn	dessiné	scale	échelle
A.G.		AS NOTED	
checked	vérifié	sheet	feuille
R.B.		- of/de -	
approved	approuvé	W.O.no.	D.T.no.
R.B.			
dwg.no.			dessin no.
E3			

U72 - FLEXIBLE CABIN LABORATORY

NRC UPLANDS CAMPUS, OTTAWA, ON
MECHANICAL



GENERAL NOTES

- CONTRACTORS TO CHECK AND VERIFY ALL DIMENSIONS ON SITE PRIOR TO DEMOLITION OR CONSTRUCTION AND REPORT ANY ERRORS OR OMISSIONS TO DEPARTMENTAL REPRESENTATIVE.
- CONTRACTORS MUST VISIT THE SITE & FULLY FAMILIARIZE THEMSELVES WITH THE SCOPE OF THE WORK.
- PREVENT THE SPREAD OF DUST & DEBRIS BEYOND THE WORK AREA AND CLEAN ALL SURFACES AT COMPLETION.
- MAKE GOOD ALL SURFACES AFFECTED BY THIS WORK.
- COORDINATE ALL SHUTDOWNS WITH THE DEPARTMENTAL REPRESENTATIVE.
- PROVIDE ALL LABOUR AND MATERIAL REQUIRED TO FORM A COMPLETE, FUNCTIONAL SYSTEM AS DESCRIBED ON DRAWINGS.

GENERAL LEGEND	
SYMBOL	DESCRIPTION
	EXISTING PIPING/DUCTWORK/EQUIPMENT
	EXISTING PIPING/DUCTWORK/EQUIPMENT TO BE REMOVED/RELOCATED
	NEW/RELOCATED PIPING/DUCTWORK/EQUIPMENT
	EXISTING PIPING/DUCTWORK/EQUIPMENT BELOW SLAB
	NEW PIPING/DUCTWORK/EQUIPMENT BELOW SLAB
(E)	DENOTES EXISTING EQUIPMENT
(R)	DENOTES RELOCATED EQUIPMENT
(N)	DENOTES NEW EQUIPMENT
(X)	DENOTES EQUIPMENT TO BE REMOVED

FIRE PROTECTION LEGEND	
SYMBOL	DESCRIPTION
	PIPE UP
	PIPE DOWN
	FIRE EXTINGUISHER C/W MOUNTING BRACKET
	RECESSED FIRE EXTINGUISHER
	SEMI-RECESSED FIRE EXTINGUISHER
	FIRE HOSE CABINET
	FIRE DEPARTMENT SIAMESE CONNECTION
	TEST HEADER (500 U.S. GPM) (32 L/S)

PLUMBING LEGEND	
SYMBOL	DESCRIPTION
	PIPING BELOW GRADE/SLAB
	DOMESTIC COLD WATER PIPING
	DOMESTIC HOT WATER PIPING
	DOMESTIC HOT WATER RECIRCULATION PIPING
	SANITARY PIPING
	STORM PIPING
	VENT PIPING
	CONDENSATE DRAIN
	FLOOR DRAIN (TYPE)
	ROOF DRAIN (TYPE)
	PIPING OFFSET
	BRANCH PIPING DOWN
	PIPING DOWN
	PIPING UP
	REDUCER
	FLOW DIRECTION
	PIPE BREAK
	CAP
	RUNNING P-TRAP
	P-TRAP
	DRAIN ASSEMBLY
	CLEAN OUT
	WALL CLEAN OUT
	FLOOR CLEAN OUT
	ISOLATION VALVES
	PRESSURE REDUCING VALVE (PRV)
	CIRCUIT BALANCING VALVE (CBV)
	STRAINER
	CHECK VALVE
	FLEXIBLE CONNECTION
	UNION
	RELIEF VALVE
	DRAIN VALVE C/W CAP & CHAIN
	BACK FLOW PREVENTER (TYPE)
	NON-FREEZE HOSE BIBB
	PUMP (P)
	CONDENSATE PUMP (CP)
	FLOW METER (TYPE)
	THERMOMETER
	PRESSURE GAUGE

HVAC LEGEND	
SYMBOL	DESCRIPTION
	RECTANGULAR DUCTWORK
	ROUND DUCTWORK
	ACOUSTICALLY LINED DUCTWORK (RETURN OR SUPPLY)
	THERMALLY INSULATED DUCTWORK (RETURN OR SUPPLY)
	SILENCER (SIL)
	ROUND DUCTWORK OFFSET
	RECTANGULAR DUCTWORK OFFSET
	DUCTWORK UP
	DUCTWORK DOWN
	RECTANGULAR TO ROUND TRANSITION
	ECCENTRIC RECTANGULAR TO ROUND TRANSITION
	ECCENTRIC TRANSITION
	TAKE-OFF C/W BALANCING DAMPER
	TAKE-OFF
	SQUARE SUPPLY DIFFUSER (TYPE)
	LINEAR SUPPLY DIFFUSER (TYPE)
	RETURN GRILLE (RG)
	EXHAUST GRILLE (EG)
	TRANSFER GRILLE (TG)
	WALL GRILLE (TYPE)
	LOUVRE (L)
	TRANSFER OPENING (TO)
	ACOUSTICALLY LINED TRANSFER DUCT (TD)
	FIRE DAMPER (FD)
	SMOKE DAMPER (SD)
	COMBINATION FIRE/SMOKE DAMPER
	BALANCING DAMPER (BD)
	BACK DRAFT DAMPER (BDD)
	FLEXIBLE CONNECTION
	TURNING VANES
	ACCESS DOOR
	MOTORIZED DAMPER
	VARIABLE AIR VOLUME BOX (VAV)
	VARIABLE AIR VOLUME BOX C/W REHEAT COIL
	FAN POWERED BOX (FPB)
	INLINE CABINET FAN (TYPE)
	REHEAT COIL (RH)
	DIFFUSER TAG
	DIFFUSER TYPE
	AIRFLOW (L/S)(CFM)
	SIZE (mm)(in)

DRAWING LIST	
SYMBOL	DESCRIPTION
M1	MECHANICAL LEGENDS
M2	MECHANICAL SCHEDULES
M3	MECHANICAL DETAILS
M4	MECHANICAL PLUMBING & UTILITIES - NEW WORK
M5	MECHANICAL HVAC - NEW WORK

CONTROLS LEGEND	
SYMBOL	DESCRIPTION
	LOW VOLTAGE CONTROL WIRING
	PNEUMATIC CONTROL TUBING
	TEMPERATURE SENSOR
	SPEED CONTROLLER
	HUMIDITY SENSOR

2016-05-15	ISSUED FOR 50% REVIEW	
DATE	REVISION	REF



GOODKEY WEEDMARK ASSOCIATES LIMITED
1688 Woodward Dr. Ottawa Ontario Canada K2C 3R8
613 727-5111 (Voice)
613 727-5115 (Fax)
www.gwai.com (Web)
2016-236 (Job#)

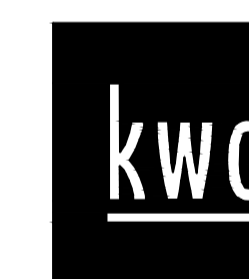

383 Parkdale Avenue, Suite 201
Ottawa Ontario Canada K1Y 4R4
KWC ARCHITECTS INC.
PHONE: (613) 238-2117
FAX: (613) 238-6595
E MAIL: kwc@kwc-arch.com

- Verify all dimensions and site conditions and be responsible for same
- Vérifier toutes les dimensions et l'état des lieux et en assumer la responsabilité

A	A Detail no. No. du détail	A
B	B Location drawing no. sur dessin no.	B
C	C Drawing no. dessin no.	C

project projet

U72 - FLEXIBLE CABIN LABORATORY

NRC UPLANDS CAMPUS

OTTAWA, ON

drawing dessin

MECHANICAL
GENERAL LIST LEGENDS

designed	conçu	date	date
FL		Jun 2016	

drawn	dessiné	scale	échelle
MP		AS NOTED	

checked	vérifié	sheet	feuille
FL		1 of/de	5

approved	approuvé	W.O.no.	D.T.no.
FL			

dwg.no.	dessin no.
M1	

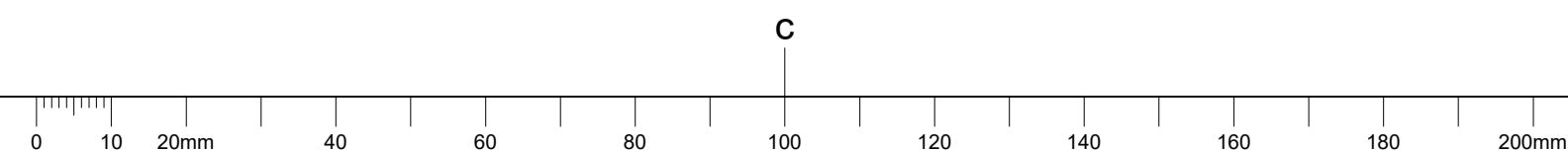



GENERAL NOTES

- CONTRACTORS TO CHECK AND VERIFY ALL DIMENSIONS ON SITE PRIOR TO DEMOLITION OR CONSTRUCTION AND REPORT ANY ERRORS OR OMISSIONS TO DEPARTMENTAL REPRESENTATIVE.
- CONTRACTORS MUST VISIT THE SITE & FULLY FAMILIARIZE THEMSELVES WITH THE SCOPE OF THE WORK.
- PREVENT THE SPREAD OF DUST & DEBRIS BEYOND THE WORK AREA AND CLEAN ALL SURFACES AT COMPLETION.
- MAKE GOOD ALL SURFACES AFFECTED BY THIS WORK.
- COORDINATE ALL SHUTDOWNS WITH THE DEPARTMENTAL REPRESENTATIVE.
- PROVIDE ALL LABOUR AND MATERIAL REQUIRED TO FORM A COMPLETE, FUNCTIONAL SYSTEM AS DESCRIBED ON DRAWINGS.

PUMP SCHEDULE											
UNIT NO.	LOCATION	FUNCTION	TYPE	PUMP DATA		ELECTRICAL DATA				BASIS OF DESIGN	REMARKS
				DESIGN FLOW (L/s)/(GPM)	DESIGN HEAD (kPa)/(ft)	HP	WATTS	AMPS	V/PH/Hz		
HP-1	MECHANICAL ROOM	HEATING LOOP	INLINE	-	-	-	-	-	-	HK030	-

NOTES: 1. FOR DETAILS REFER TO SPECIFICATIONS.

CONDENSER UNIT SCHEDULE										
UNIT NO.	LOCATION	FUNCTION	AMBIENT TEMP. (°C)	NOMINAL TONS	STAGES H.G.B.P.	ELECTRICAL DATA			BASIS OF DESIGN MAKE/MODEL	REMARKS
						V/PH/Hz	FLA/MCA/MOC			
C1	ROOF	ERV-1	-	-	-	-	-	-	-	-

NOTES: 1. FOR DETAILS REFER TO SPECIFICATIONS.

REFRIGERANT FAN COIL SCHEDULE													
UNIT NO.	LOCATION	NOMINAL SIZE (TON)	TYPE	AIR FLOW (L/s)	TOTAL COOLING (kW)	SENSIBLE COOLING (kW)	E.A.T. dB/Wb (°C)	DIMENSIONS (mmL x mmH x mmD)		ELECTRICAL DATA		BASIS OF DESIGN	REMARKS
										MOTOR HP	V/PH/Hz		
FC1	-	3	-	1200	-	-	-	-	-	-	-	-	-
FC2	-	2	-	800	-	-	-	-	-	-	-	-	-
FC3	-	1.5	-	600	-	-	-	-	-	-	-	-	-

NOTES: 1. FOR DETAILS REFER TO SPECIFICATIONS.

ENERGY RECOVERY VENTILATOR															
UNIT NO.	LOCATION	SUPPLY FAN DATA			EXHAUST FAN DATA			ENERGY RECOVERY DATA				ELECTRICAL DATA		BASIS OF DESIGN	REMARKS
		AIR FLOW (L/s)	EXTERNAL STATIC PRESSURE (Pa)	HP	AIR FLOW (L/s)	EXTERNAL STATIC PRESSURE (Pa)	HP	EAT °Cdb/°Cwb		LAT °Cdb/°Cwb		V/PH/Hz	FLA/MCA/MOC		
								SUMMER	WINTER	SUMMER	WINTER				
ERV-1	MECHANICAL ROOM	500	500	-	500	120	-	-	-	-	-	-/-/-	-/-/-	TEMPEFF-RG-1800	-

NOTES: 1. FOR DETAILS REFER TO SPECIFICATIONS.
 2. MANUFACTURER NAME & MODEL NUMBER REPRESENTS ACCEPTABLE QUALITY STANDARD ONLY. ALTERNATIVE MATERIALS MAY BE APPROVED AFTER REVIEW OF TECHNICAL INFORMATION BY ENGINEER.
 3. TYPICAL ENERGY RECOVERY CONDITIONS: SUMMER - E.A.T. (°C) SHALL BE 35°C/23.9°C
 WINTER - E.A.T. (°C) SHALL BE -21.2°C

BOILER SCHEDULE										
UNIT NO.	LOCATION	FLOW (L/s)	INPUT (kW)	OUTPUT (kW)	AFUE EFFICIENCY (%)	TYPE	V/PH/Hz	BASIS OF DESIGN MAKE/MODEL	REMARKS	
										B1
B2	BOILER ROOM	0.97	47	43	92	CONDENSING BACK MOUNT	120/1/60	VISSMANN VITODANS 200-W-B2HA-45	-	
B3	BOILER ROOM	0.97	47	43	92	CONDENSING BACK MOUNT	120/1/60	VISSMANN VITODANS 200-W-B2HA-45	-	

NOTES: 1. FOR DETAILS REFER TO SPECIFICATIONS.
 2. MANUFACTURER NAME & MODEL NUMBER REPRESENT ACCEPTABLE QUALITY STANDARD ONLY.
 3. ALTERNATIVE MATERIALS MAY BE APPROVED AFTER REVIEW OF TECHNICAL INFORMATION BY ENGINEER.

CHILLER SCHEDULE																							
UNIT NO.	LOCATION	APPLICATION	TYPE	CAPACITY (kW)	STAGES	POWER INPUT (kW)	EVAPORATOR				WATER CONDENSER				PHYSICAL DATA				ELECTRICAL DATA		BASIS OF DESIGN	REMARKS	
							EWT (°F)	LWT (°F)	DESIGN FLOW (GPM)	PRESSURE DROP (FT WC)	EWT (°F)	LWT (°F)	DESIGN FLOW (GPM)	PRESSURE DROP (FT WC)	HEIGHT (IN)	WIDTH	LENGTH	COIL PULL (INCHES)	dBA	V/PH/Hz			FLA/MCA/MOC
CH-1	OUTSIDE	SUB COOLING	INLINE	30		67.5	44	34	148	13.6	85	95	196	9.43					82	-/-/-	-/-/-	AERMEC	-
CH-2	OUTSIDE	SUB COOLING	INLINE	30		67.5	44	34	148	13.6	85	95	196	9.43					82	-/-/-	-/-/-	AERMEC	-

NOTES: 1. FOR DETAILS REFER TO SPECIFICATIONS.

FORCE FLOW UNIT SCHEDULE																
UNIT NO.	LOCATION	ARRANGEMENT	AIR FLOW (L/s)	WATER FLOW (L/s)	NUMBER OF ROWS	CAPACITY (kW)	EWT (°C)	LWT (°C)	LAT (°C)	DIMENSIONS (mmL x mmH x mmD)	ELECTRICAL DATA			BASIS OF DESIGN	REMARKS	
											MOTOR HP	V/PH/Hz	FLA			
FF1	VESTIBULE	FULLY RECESSED WALL CABINET MOUNT	405	0.17	1	10.0	65.6	51.7	47	1550x686x241	1 x 1/10 1 x 1/15	120/1/60	2.2A	STERLING RWI-1130-08	C/W LIMITED ACCESS FASTENERS, MOTOR STARTED WITH OVERLOADS, FAN RELAY FOR BAS CONTROL	
FF2	VESTIBULE	FULLY RECESSED WALL CABINET MOUNT	405	0.17	1	10.0	65.6	51.7	47	1550x686x241	1 x 1/10 1 x 1/15	120/1/60	2.2A	STERLING RWI-1130-08	C/W LIMITED ACCESS FASTENERS, MOTOR STARTED WITH OVERLOADS, FAN RELAY FOR BAS CONTROL	

NOTES: 1. FOR DETAILS REFER TO SPECIFICATIONS.
 2. ALL INTAKE AND EXHAUST VENTING SHALL BE SIZED BY BOILER MANUFACTURER.
 3. ALL BOILERS SEISMICALLY MOUNTED ON HOUSEKEEPING PAD.
 4. SYSTEM SIZED FOR FUTURE EXPANSIONS. ALLOW FOR FUTURE BOILER AS INDICATED ON DRAWINGS.
 5. FIELD BUILT BOILER TO MANUFACTURER'S INSTALLATION INSTRUCTIONS.

Goodkey Weedmark Consulting Engineers
 GOODKEY WEEDMARK ASSOCIATES LIMITED
 1688 Woodward Dr. Ottawa Ontario Canada K2C 3R8
 613 727-5111 (Voice)
 613 727-5115 (Fax)
 www.gwal.com (Web)
 2016-236 (Job#)

kwc
 383 Parkdale Avenue, Suite 201
 Ottawa Ontario Canada K1Y 4R4
KWC ARCHITECTS INC.
 PHONE: (613) 238-2117
 FAX: (613) 238-6595
 E-MAIL: kwc@kwc-arch.com

- o Verify all dimensions and site conditions and be responsible for same
- o Vérifier toutes les dimensions et l'état des lieux et en assumer la responsabilité

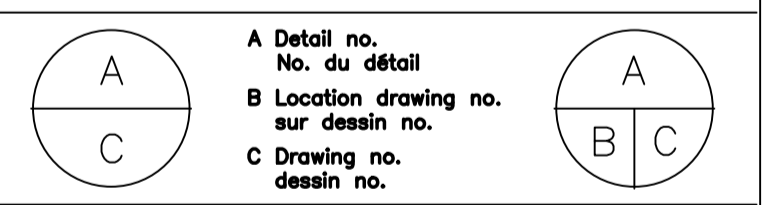

project **U72 - FLEXIBLE CABIN LABORATORY** projet
NRC UPLANDS CAMPUS
OTTAWA, ON
 drawing **MECHANICAL SCHEDULES** dessin
 designed **FL** conçu **Jun. 2016** date
 drawn **MP** dessiné **AS NOTED** scale **AS NOTED** échelle
 checked **FL** vérifié **2** of/de **5** sheet **2** of/de **5** feuille
 approved **FL** approuvé **W.O.no.** D.T.no.
 drwg.no. **M2** dessin no.

GENERAL NOTES

- CONTRACTORS TO CHECK AND VERIFY ALL DIMENSIONS ON SITE PRIOR TO DEMOLITION OR CONSTRUCTION AND REPORT ANY ERRORS OR OMISSIONS TO DEPARTMENTAL REPRESENTATIVE.
- CONTRACTORS MUST VISIT THE SITE & FULLY FAMILIARIZE THEMSELVES WITH THE SCOPE OF THE WORK.
- PREVENT THE SPREAD OF DUST & DEBRIS BEYOND THE WORK AREA AND CLEAN ALL SURFACES AT COMPLETION.
- MAKE GOOD ALL SURFACES AFFECTED BY THIS WORK.
- COORDINATE ALL SHUTDOWNS WITH THE DEPARTMENTAL REPRESENTATIVE.
- PROVIDE ALL LABOUR AND MATERIAL REQUIRED TO FORM A COMPLETE, FUNCTIONAL SYSTEM AS DESCRIBED ON DRAWINGS.

2016-05-15	ISSUED FOR 50% REVIEW	
DATE	REVISION	REF



GOODKEY WEEDMARK ASSOCIATES LIMITED
 1688 Woodward Dr. Ottawa Ontario Canada K2C 3R8
 613 727-5111 (Voice)
 613 727-5115 (Fax)
 www.gwal.com (Web)
 2016-236 (Job#)



- Verify all dimensions and site conditions and be responsible for same
- Vérifier toutes les dimensions et l'état des lieux et en assumer la responsabilité

A	A Detail no.	A
C	No. du détail	B
	B Location drawing no.	C
	sur dessin no.	
	C Drawing no.	
	dessin no.	

project **U72 - FLEXIBLE CABIN LABORATORY** projet

NRC UPLANDS CAMPUS
OTTAWA, ON

drawing **MECHANICAL DETAILS** dessin

designed	conçu	date	date
FL		Jun. 2016	
drawn	dessiné	scale	échelle
MP		AS NOTED	
checked	vérifié	sheet	feuille
FL		3	of/de 5
approved	approuvé	W.O.no.	D.T.no.
FL			
dwg.no.			dessin no.
M3			

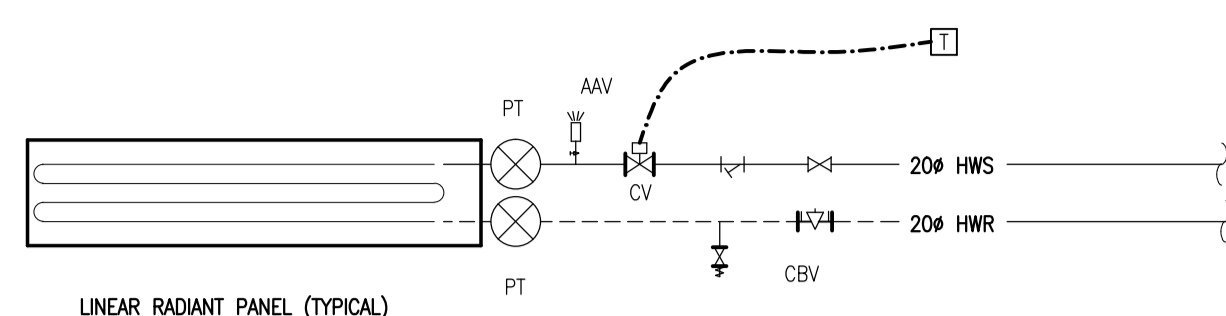

1 LINEAR RADIANT PANEL CONNECTION DETAIL
 M3 NTS

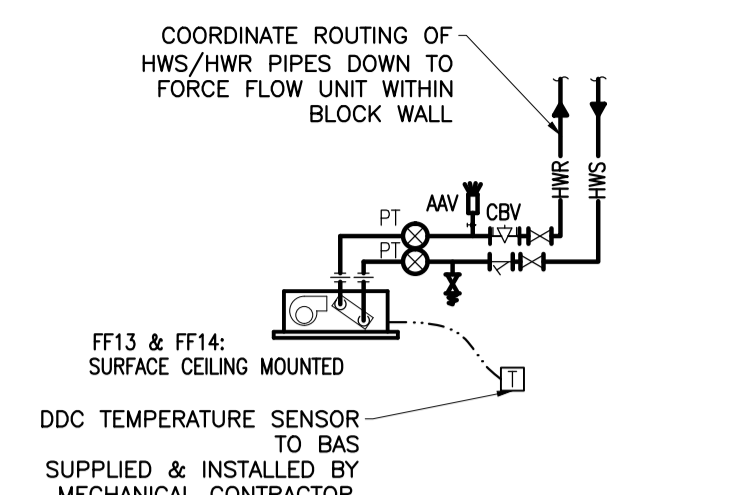

4 FORCE FLOW DETAIL (CEILING)
 M3 NTS

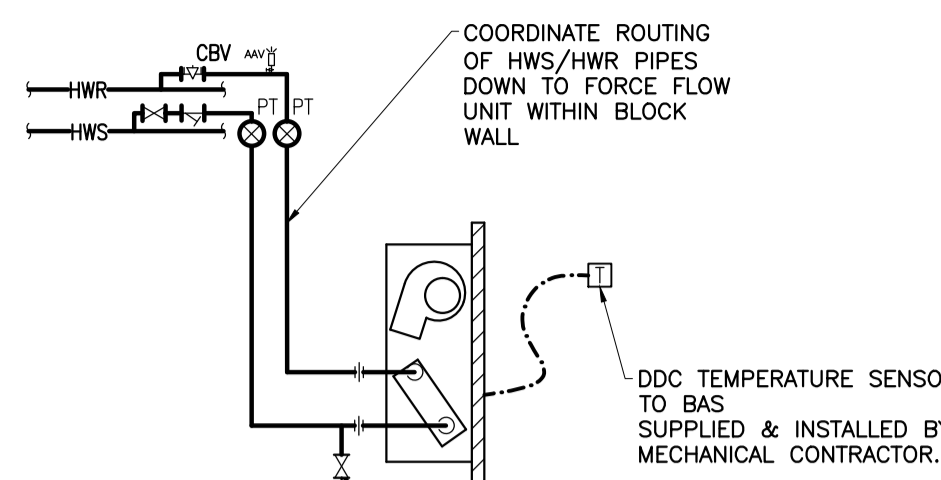

5 FORCE FLOW DETAIL (WALL)
 M3 NTS

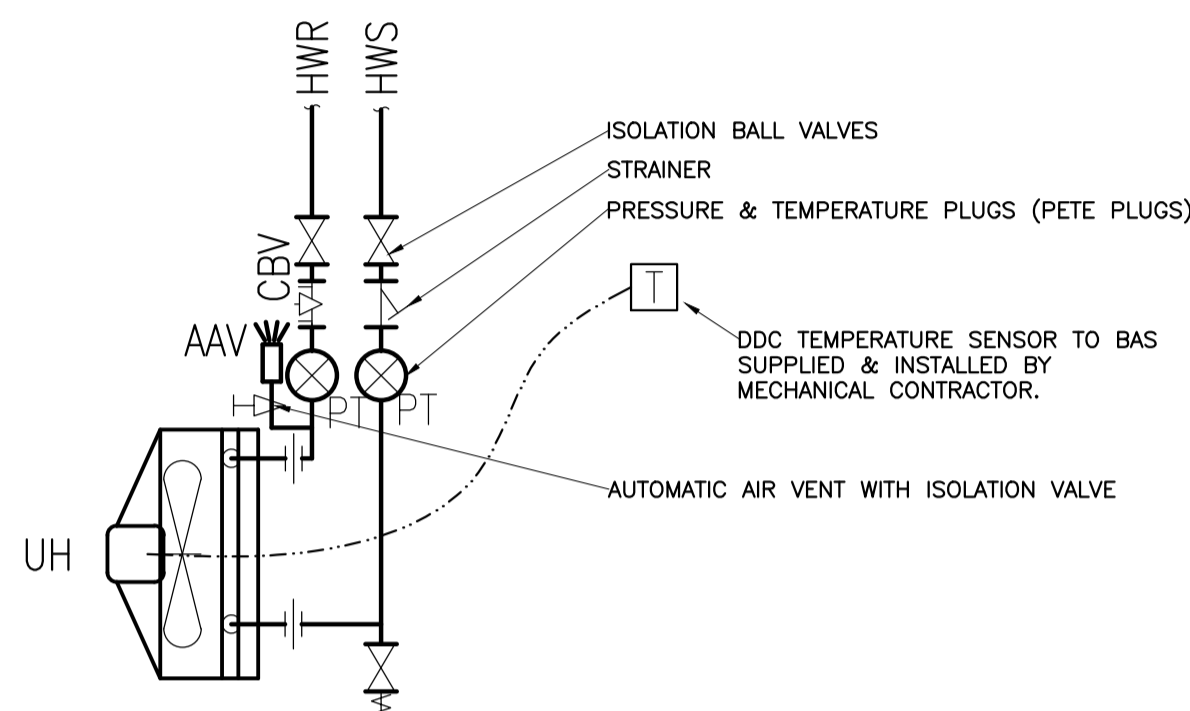

2 UNIT HEATER CONNECTION DETAIL
 M3 NTS

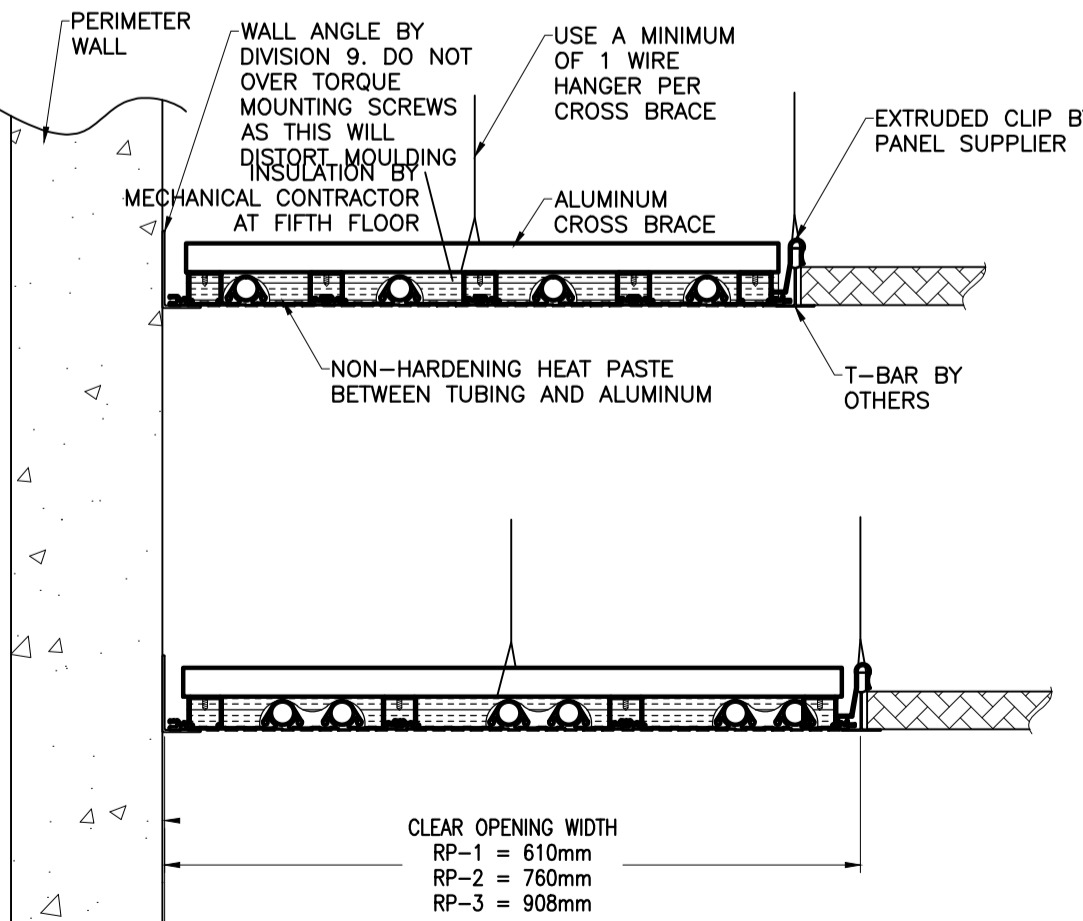
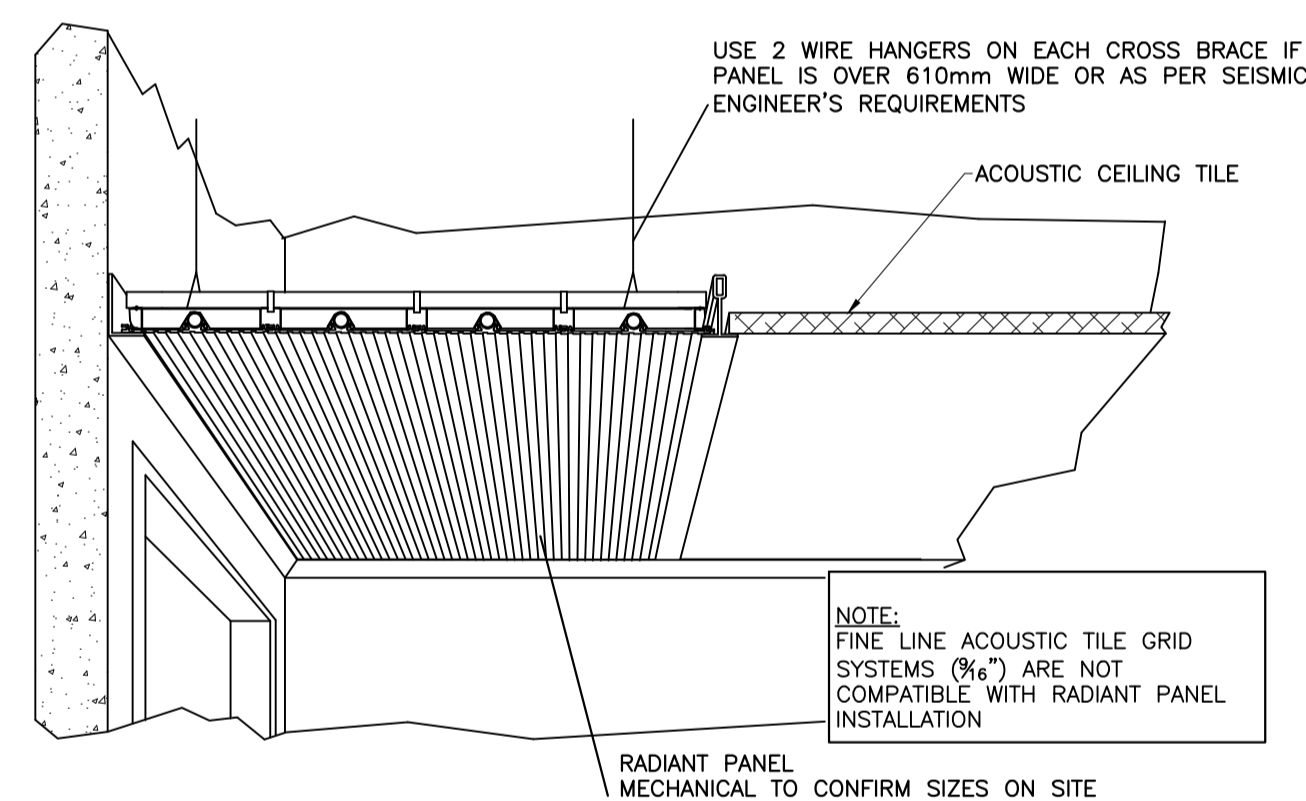

3 LINEAR RADIANT PANEL DETAIL
 M3 NTS

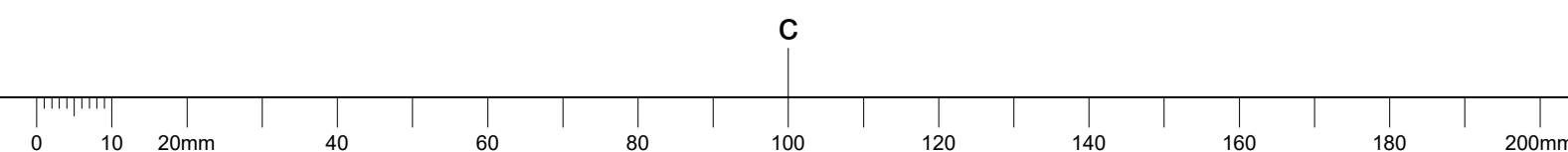



GENERAL NOTES

- CONTRACTORS TO CHECK AND VERIFY ALL DIMENSIONS ON SITE PRIOR TO DEMOLITION OR CONSTRUCTION AND REPORT ANY ERRORS OR OMISSIONS TO DEPARTMENTAL REPRESENTATIVE.
- CONTRACTORS MUST VISIT THE SITE & FULLY FAMILIARIZE THEMSELVES WITH THE SCOPE OF THE WORK.
- PREVENT THE SPREAD OF DUST & DEBRIS BEYOND THE WORK AREA AND CLEAN ALL SURFACES AT COMPLETION.
- MAKE GOOD ALL SURFACES AFFECTED BY THIS WORK.
- COORDINATE ALL SHUTDOWNS WITH THE DEPARTMENTAL REPRESENTATIVE.
- PROVIDE ALL LABOUR AND MATERIAL REQUIRED TO FORM A COMPLETE, FUNCTIONAL SYSTEM AS DESCRIBED ON DRAWINGS.

2016-05-15	ISSUED FOR 50% REVIEW	
DATE	REVISION	REF



GOODKEY WEEDMARK ASSOCIATES LIMITED
 1688 Woodward Dr. Ottawa Ontario Canada K2C 3R8
 613 727-5111 (Voice)
 613 727-5115 (Fax)
 www.gwal.com (Web)
 2016-236 (Job#)

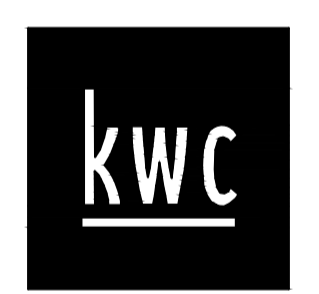

383 Parkdale Avenue, Suite 201
 Ottawa Ontario Canada K1Y 4R4
KWC ARCHITECTS INC.
 PHONE: (613) 238-2117
 FAX: (613) 238-6595
 E-MAIL: kwc@kwc-arch.com

- Verify all dimensions and site conditions and be responsible for same
- Vérifier toutes les dimensions et l'état des lieux et en assumer la responsabilité

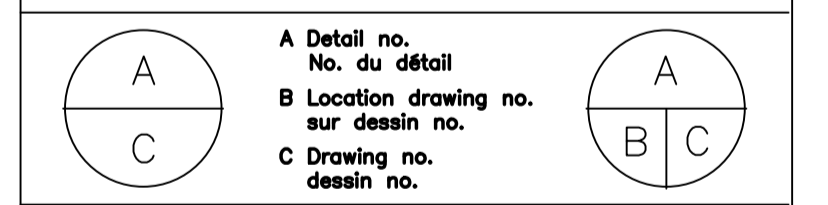

project
U72 - FLEXIBLE CABIN LABORATORY
NRC UPLANDS CAMPUS
OTTAWA, ON
 drawing
 MECHANICAL
 PLUMBING UTILITIES
 NEW WORK

designed	conçu	date	date
FL		Jun. 2016	
drawn	dessiné	scale	échelle
MP		AS NOTED	
checked	vérifié	sheet	feuille
FL		4	of/de 5
approved	approuvé	W.O.no.	D.T.no.
FL			
dwg.no.			dessin no.

M4

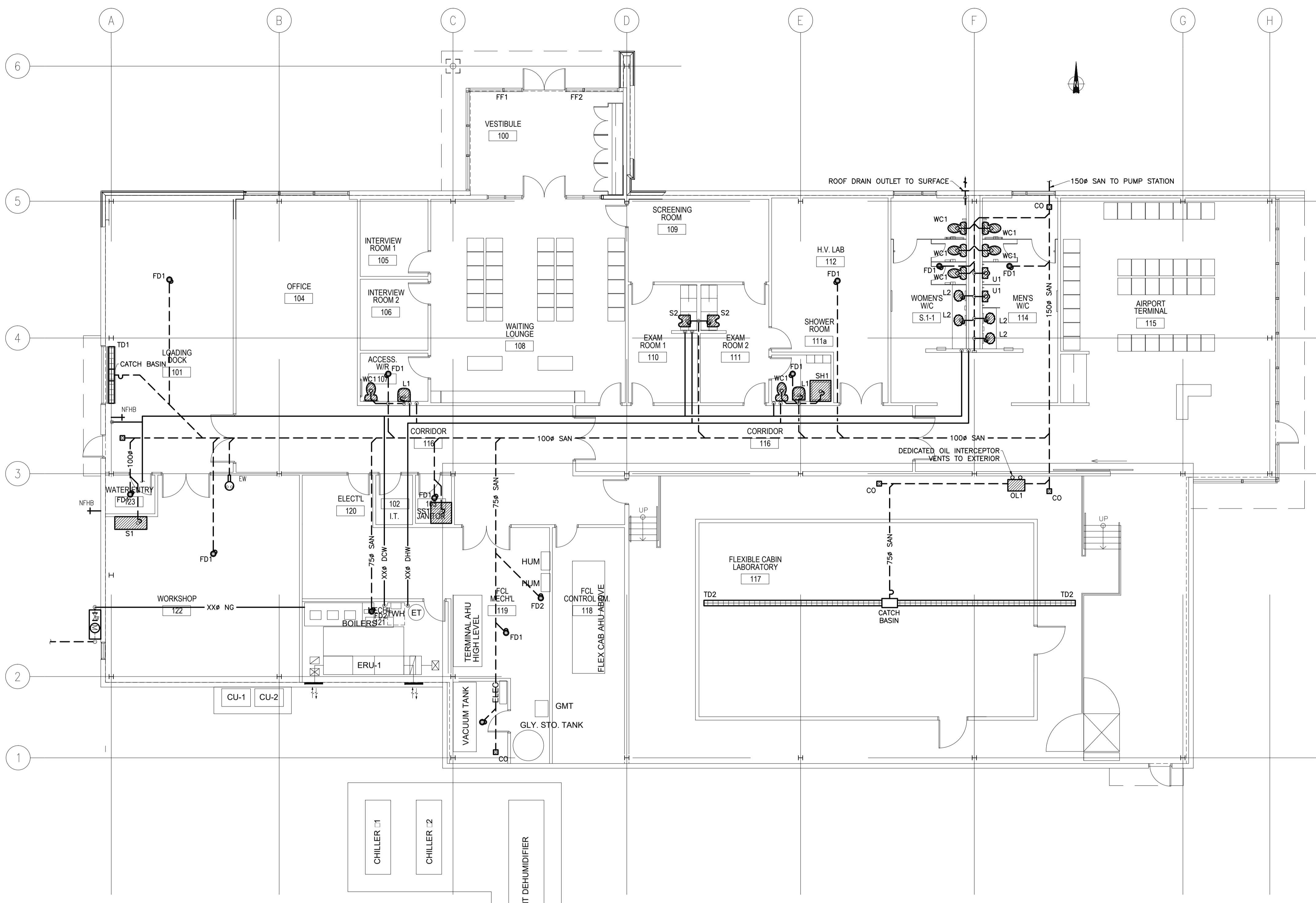

1 PLUMBING - NEW WORK
 M4 1:100

DESCRIPTION OF WORK: NEW WORK

GENERAL NOTES

- CONTRACTORS TO CHECK AND VERIFY ALL DIMENSIONS ON SITE PRIOR TO DEMOLITION OR CONSTRUCTION AND REPORT ANY ERRORS OR OMISSIONS TO DEPARTMENTAL REPRESENTATIVE.
- CONTRACTORS MUST VISIT THE SITE & FULLY FAMILIARIZE THEMSELVES WITH THE SCOPE OF THE WORK.
- PREVENT THE SPREAD OF DUST & DEBRIS BEYOND THE WORK AREA AND CLEAN ALL SURFACES AT COMPLETION.
- MAKE GOOD ALL SURFACES AFFECTED BY THIS WORK.
- COORDINATE ALL SHUTDOWNS WITH THE DEPARTMENTAL REPRESENTATIVE.
- PROVIDE ALL LABOUR AND MATERIAL REQUIRED TO FORM A COMPLETE, FUNCTIONAL SYSTEM AS DESCRIBED ON DRAWINGS.

2016-05-15	ISSUED FOR 50% REVIEW	
DATE	REVISION	REF



GOODKEY WEEDMARK ASSOCIATES LIMITED
 1688 Woodward Dr. Ottawa Ontario Canada K2C 3R8
 613 727-5111 (Voice)
 613 727-5115 (Fax)
 www.gwal.com (Web)
 2016-236 (Job#)

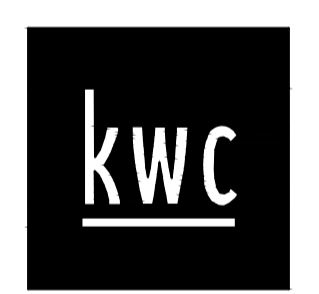

383 Parkdale Avenue, Suite 201
 Ottawa Ontario Canada K1Y 4R4
KWC ARCHITECTS INC.
 PHONE: (613) 238-2117
 FAX: (613) 238-6595
 E-MAIL: kwc@kwc-arch.com

- o Verify all dimensions and site conditions and be responsible for same
- o Vérifier toutes les dimensions et l'état des lieux et en assumer la responsabilité

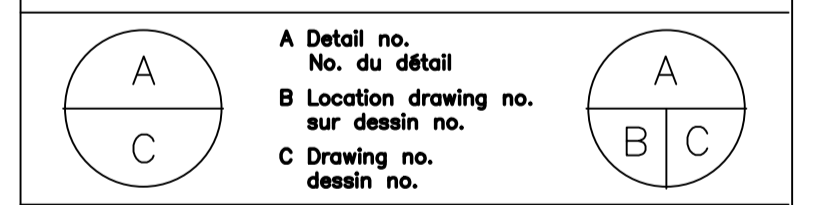

project	U72 - FLEXIBLE CABIN LABORATORY			project
	NRC UPLANDS CAMPUS			
	OTTAWA, ON			
drawing	MECHANICAL HVAC NEW WORK			dessin
designed	conçu	date	date	
FL		Jun. 2016		
drawn	dessiné	scale	échelle	
MP		AS NOTED		
checked	vérifié	sheet	feuille	
FL		5 of/de 5		
approved	approuvé	W.O.no.	D.T.no.	
FL				
dwg.no.	dessin no.			
M5				

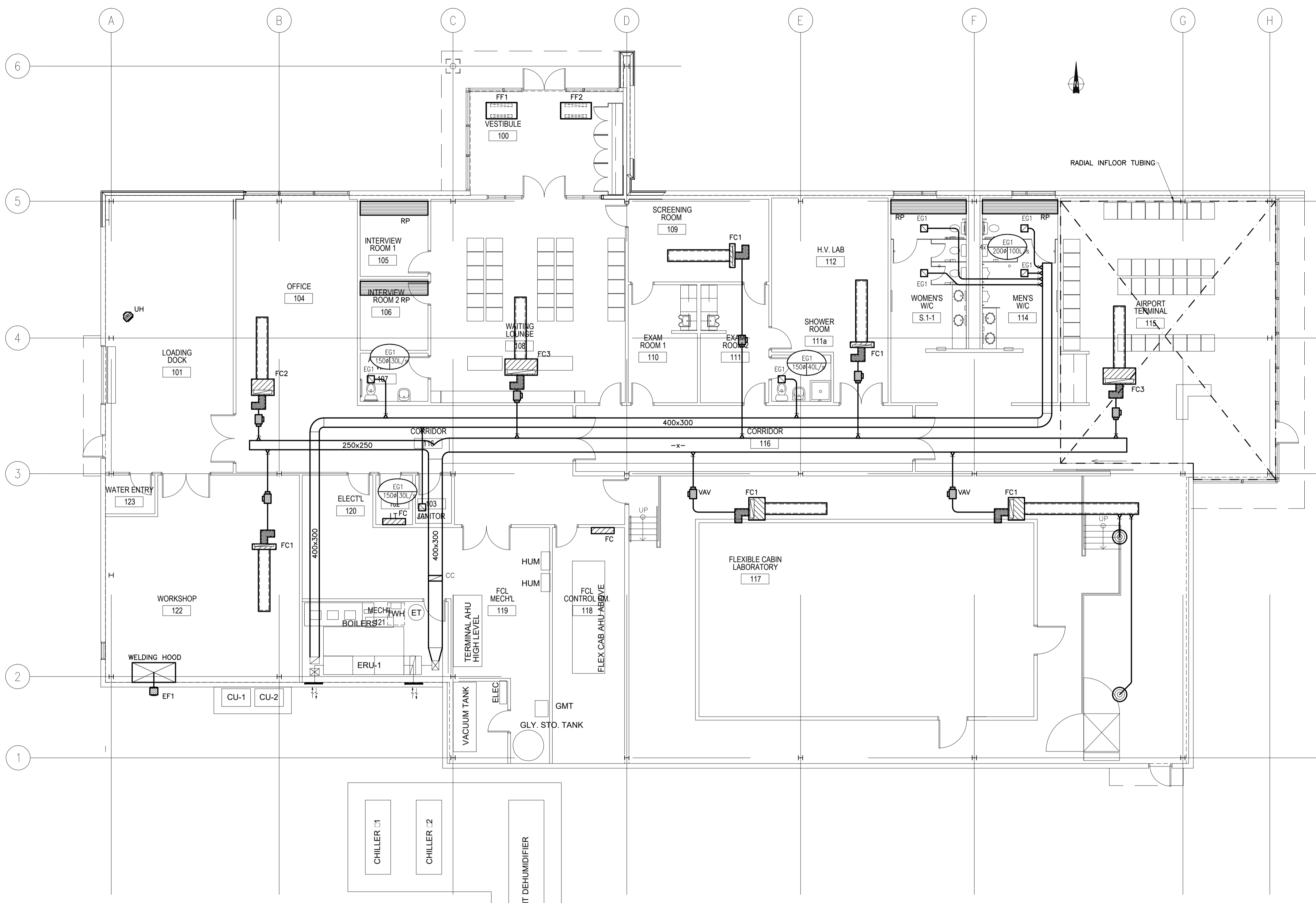

1 HVAC - NEW WORK
 M5 1:100

DESCRIPTION OF WORK: NEW WORK

GENERAL NOTES

• SEE DRAWING A103 AND A104 FOR DETAILS AND NOTES

ISSUED FOR 50% REVIEW 15/06/2016

o Verify all dimensions and site conditions and be responsible for same
 o Vérifier toutes les dimensions et l'état des lieux et en assumer la responsabilité

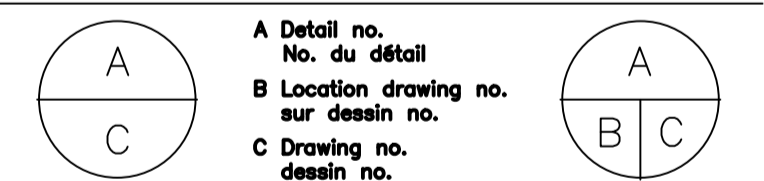

project project

NRC U72

RESEARCH ROAD

OTTAWA, ON

drawing dessin

DETAILS DRAWING 1

designed congu date date

KW / LPL JUN 2016

drawn LPL dessin scale échelle

N/A

checked KW vérifié sheet 3 of/de 4 feuille

approved KW approuvé W.O.no. D.T.no.

KW -----

dwg.no. dessin no.

A102

1
 A100 COMMUNICATION AND HYDRO DUCTS
 SCALE N/A

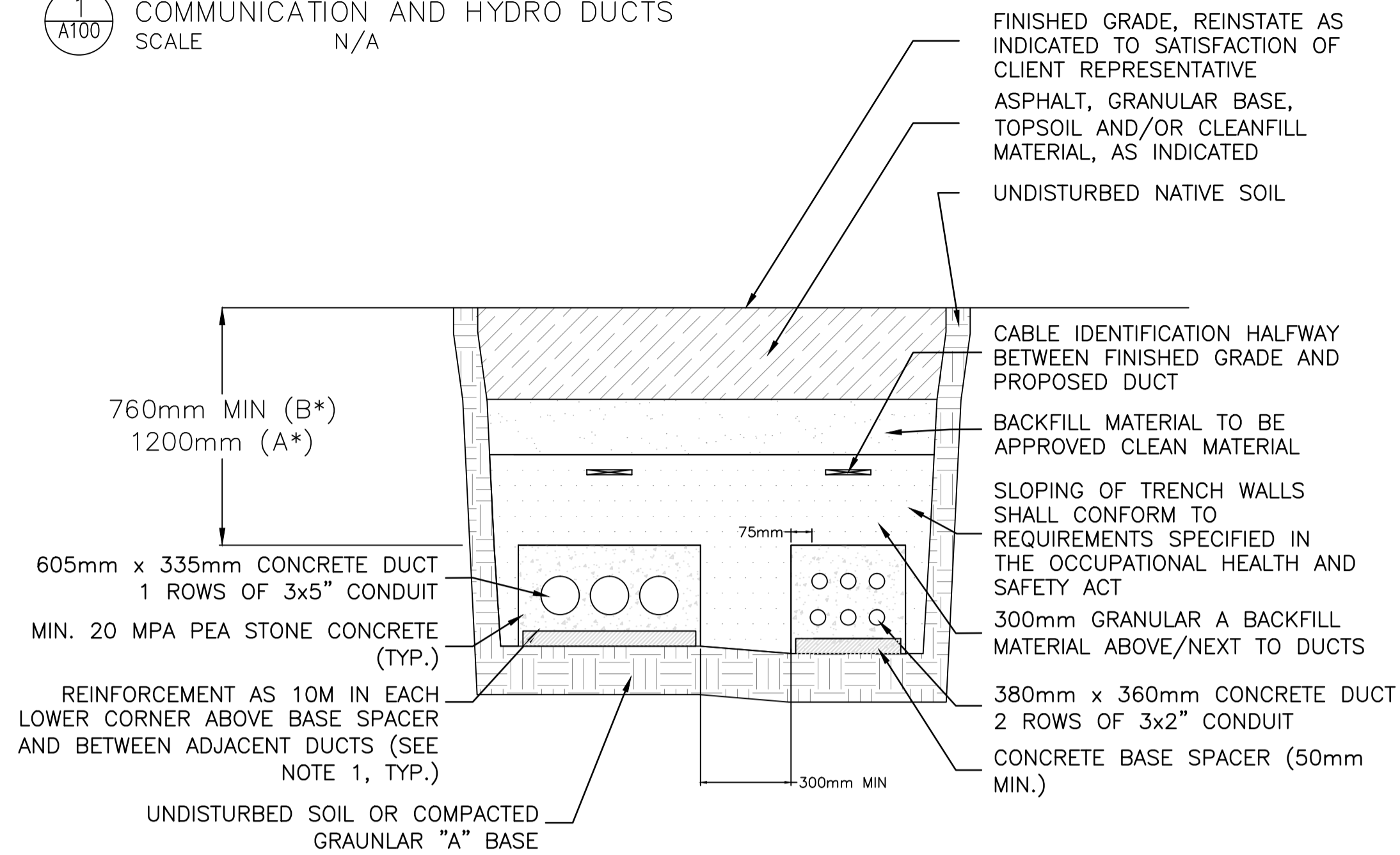

NOTES

1. REINFORCING RODS FULL LENGTH OF CONCRETE ENCASED DUCTS. OVERLAP JOINTS BY 150mm ON BASE SPACERS AND TIE BOTH ENDS. DRILL AND DOWEL RODS 85mm INTO WALL OF CONCRETE STRUCTURE. A MINIMUM 25mm COVER TO REINFORCING ROD IS REQUIRED.
2. DUCT SPACERS TO BE PLACED AT A MAXIMUM OF 1500mm AND WITHIN 150mm OF COUPLING. PLASTIC DUCT SPACERS TO BE USED ONLY IF CONCRETE DUCT SPACERS ARE UNAVAILABLE.
3. FORMS REQUIRED FOR BOTH SIDES OF EACH FULL LENGTH OF CONCRETE ENCASED DUCT STRUCTURE.
4. DUCTS AND TRENCHES MUST BE INSPECTED BY CLIENT REPRESENTATIVE BEFORE ANY CONCRETE IS POURED.
5. CONTRACTOR MUST ENSURE THAT ALL DUCTS ARE CLEANED, RODDED AND THAT AN 8mm POLYPROPYLENE ROPE IS LEFT IN EACH DUCT.
6. ALL BACKFILL MATERIAL MUST BE APPROVED BY CLIENT REPRESENTATIVE.
7. ANY DEVIATION OF TEH STANDARD COVER MUST BE APPROVED BY THE CLIENT REPRESENTATIVE.
8. BELL END TERMINATORS ARE TO BE USED WHEN TERMINATING DUCTS IN STRUCTURES.
9. ALL MEASUREMENTS ARE IN MILLIMETERS UNLESS OTHERWISE NOTED.
10. THIS DETAIL IS NOT DRAWN TO SCALE.

* COVER DEPTHS CORRESPOND TO THE LOCATIONS SHOWN BY THE A - A' AND B - B' CROSS SECTION MARKERS ON DRAWING A100 - SERVICING AND GRADING.

2
 A100 ASPHALT DRIVEWAY, PATH, AND PADS
 SCALE N/A

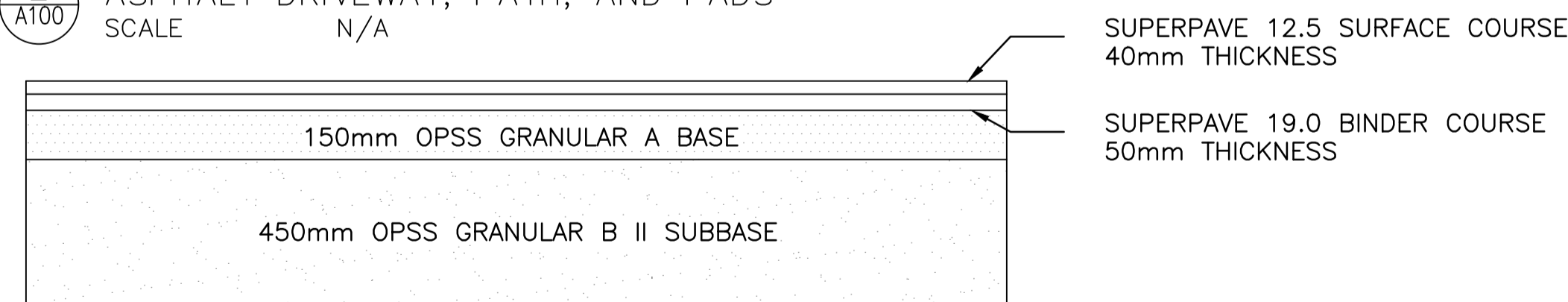

3
 A100 ASPHALT TAXIWAY
 SCALE N/A

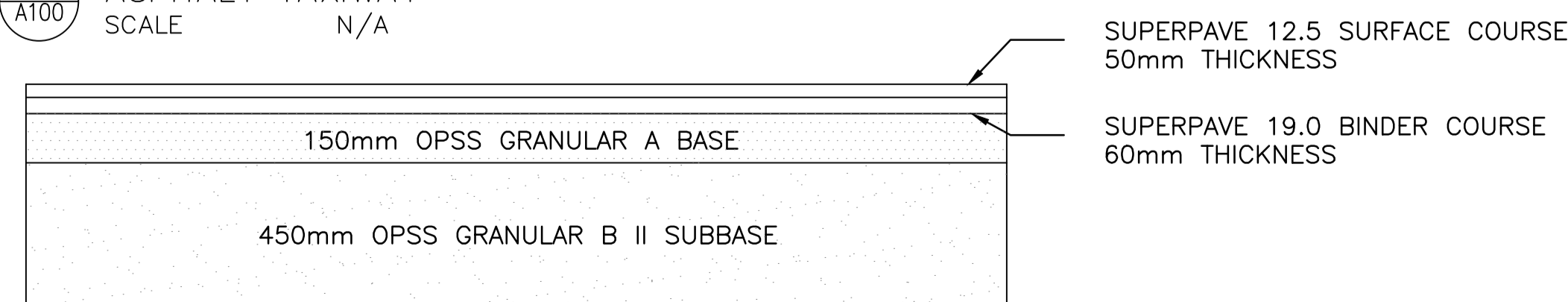

NOTES: GENERAL

1. CONTRACTOR IS RESPONSIBLE FOR ALL LAYOUT FOR CONSTRUCTION.
2. ALL ELEVATIONS / DIMENSIONS ARE IN METRIC UNITS.
3. JOB BENCH MARK - CONFIRM WITH NRC PRIOR TO UTILIZATION.
5. ALL DISTURBED AREAS SHALL BE REINSTATED TO EQUAL OR BETTER CONDITION TO THE SATISFACTION OF THE NRC REPRESENTATIVE.
6. ALL BASE AND SUB BASE GEOTECHNICAL WORK IS TO BE DONE AS PER "GEOTECHNICAL INVESTIGATION PROPOSED RESEARCH BUILDING NATIONAL RESEARCH COUNCIL UPLANDS CAMPUS 1920 RESEARCH ROAD, OTTAWA, ONTARIO", PREPARED BY GOLDER ASSOCIATES LTD. DATED DECEMBER, 2015.
7. REFER TO ARCHITECT'S SITE PLAN FOR BUILDING DIMENSIONS AND SITE LAYOUT. DIMENSIONS AND LAYOUT INFORMATION SHALL BE CONFIRMED PRIOR TO COMMENCEMENT OF CONSTRUCTION.
8. CONTRACTOR IS RESPONSIBLE FOR ALL DEWATERING, SUPPORT AND PROTECTION OF EXCAVATIONS.
9. DESIGN ELEVATIONS AS GIVEN ON THIS PLAN ARE TO BE ADHERED TO WITH NO CHANGES WITHOUT PRIOR WRITTEN APPROVAL BY THE ENGINEER.
10. U/G CONTRACTOR TO CONFIRM LOCATION(S) AND ELEVATION(S) OF EXISTING SERVICES AND STRUCTURES TO BE CONNECTED TO AND EXISTING SERVICES THAT MAY CAUSE CONFLICTS PRIOR TO CONSTRUCTION OF ANY NEW SEWER AND/OR STORM WATER WORKS. THE CLIENT REPRESENTATIVE SHALL BE INFORMED IMMEDIATELY OF ANY ERRORS, DISCREPANCIES, CONFLICTS, OMISSIONS etc THAT ARE FOUND.
12. THE CONTRACTOR SHALL VERIFY ALL SURFACE AND SUBSURFACE CONDITIONS PRIOR TO COMMENCING CONSTRUCTION BY REVIEWING THE GEOTECHNICAL INVESTIGATION REPORT "GEOTECHNICAL INVESTIGATION PROPOSED RESEARCH BUILDING NATIONAL RESEARCH COUNCIL UPLANDS CAMPUS 1920 RESEARCH ROAD, OTTAWA, ONTARIO", PREPARED BY GOLDER ASSOCIATES LTD. DATED DECEMBER, 2015.
13. THE CONTRACTOR SHALL APPRAISE HIS/HER SELF OF ALL SURFACE AND SUBSURFACE CONDITIONS TO BE ENCOUNTERED AND SHALL CARRY OUT THEIR OWN TEST PITS AS REQUIRED TO MAKE THEIR OWN INDEPENDENT ASSESSMENT OF GROUND CONDITIONS. THE CONTRACTOR SHALL NOT MAKE ANY CLAIM FOR ANY EXTRA COST DUE TO ANY SUCH GROUND CONDITIONS VARYING FROM THOSE ANTICIPATED BY THE CONTRACTOR.
14. THE CONTRACTOR SHALL COORDINATE AND PAY FOR ALL CONSTRUCTION RELATED PERMITS, FEES, INSPECTIONS AND APPROVALS REQUIRED.
15. IN PREPARATION FOR THE CONSTRUCTION OF THE NEW ASPHALTIC CONCRETE SURFACED ROADWAYS AND PARKING AREAS, ALL TOPSOIL, ORGANIC MATERIAL AND ANY LOOSE/SOFT OR WET SOIL SHOULD BE REMOVED FROM THE PROPOSED SUBGRADE SURFACE AND REPLACED WITH SUITABLE COMPACTED EARTH BORROW OR GRANULAR FILL.
16. THE CONTRACTOR IS RESPONSIBLE FOR THE INSTALLATION AND CONSTRUCTION OF ALL SEDIMENT AND EROSION CONTROL MEASURES TO ENSURE THAT SEDIMENT DOES NOT MIGRATE FROM THE CONSTRUCTION SITE. SEDIMENTS SHALL BE CONTAINED AND DISPOSED OF IN AN APPROVED MANNER. THE CONTRACTOR SHALL IMPLEMENT BEST MANAGEMENT PRACTICES, TO PROVIDE FOR PROTECTION OF THE AREA DRAINAGE SYSTEM AND THE RECEIVING WATERCOURSE, DURING CONSTRUCTION ACTIVITIES. THIS INCLUDES LIMITING THE AMOUNT OF EXPOSED SOIL, USING FILTER COLTH UNDER THE GRATES OF CATCHBASINS AND MANHOLES AND INSTALLING SILT FENCES (PER OPSD 219.110) AND OTHER EFFECTIVE SEDIMENT TRAPS.

NOTES: WATERMAIN

1. ALL WATERMAIN WORK AND MATERIAL SHALL BE IN ACCORDANCE WITH GEOTECHNICAL INVESTIGATION PROPOSED RESEARCH BUILDING NATIONAL RESEARCH COUNCIL UPLANDS CAMPUS 1920 RESEARCH ROAD, OTTAWA, ONTARIO", PREPARED BY GOLDER ASSOCIATES LTD. DATED DECEMBER, 2015.
2. ALL WATERMAIN SERVICES TO BE INSTALLED AT MINIMUM COVER OF 2.4m. IF COVER IS LESS THAN 2.4m, REFER TO CITY OF OTTAWA STANDARD W21 & W22 ON A103.
3. CONTRACTOR TO VERIFY THE EXACT LOCATION OF THE EXISTING WATER SERVICES AND PROVIDE EXCAVATION, BEDDING, BACKFILL AND REINSTATEMENT.

NOTES: SEWER

1. ALL SANITARY GRAVITY SEWERS ARE TO BE THE SIZES INDICATED, AND THE MATERIAL SHALL BE SDR 35.
2. THE BEDDING AND COVER MATERIAL FOR THE PROPOSED SANITARY SHOULD BE AS INDICATED IN "GEOTECHNICAL INVESTIGATION PROPOSED RESEARCH BUILDING NATIONAL RESEARCH COUNCIL UPLANDS CAMPUS 1920 RESEARCH ROAD, OTTAWA, ONTARIO", PREPARED BY GOLDER ASSOCIATES LTD. DATED DECEMBER, 2015.
3. SUPPLY AND INSTALL ALL PIPING AND APPURTENANCES AS SHOWN TO WITHIN 1.0m OF BUILDING WALLS. PROVIDE TEMPORARY CAPS.
4. THE CONTRACTOR IS RESPONSIBLE FOR ALL COSTS AND COORDINATION FOR ALL INSPECTION AND TESTING WITH RESPECT TO SEWER.
5. SEWER TO BE INSTALLED WITH A MINIMUM OF 2.0m COVER. THERMAL INSULATION TO BE INSTALLED WHERE REQUIRED.

4 INSULATION DETAIL
SCALE N/A

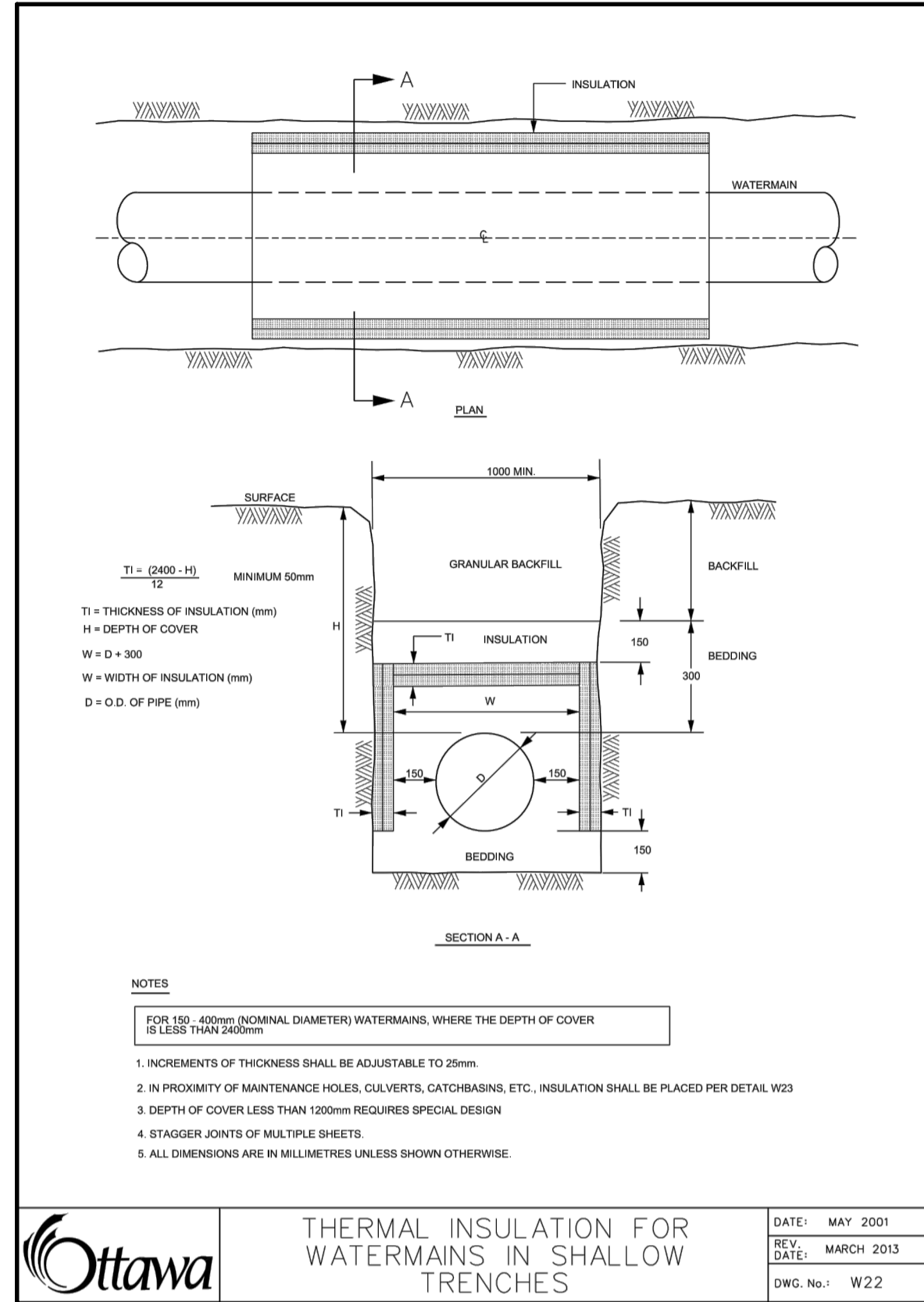

5 FENCE AND GATE DETAIL
SCALE N/A

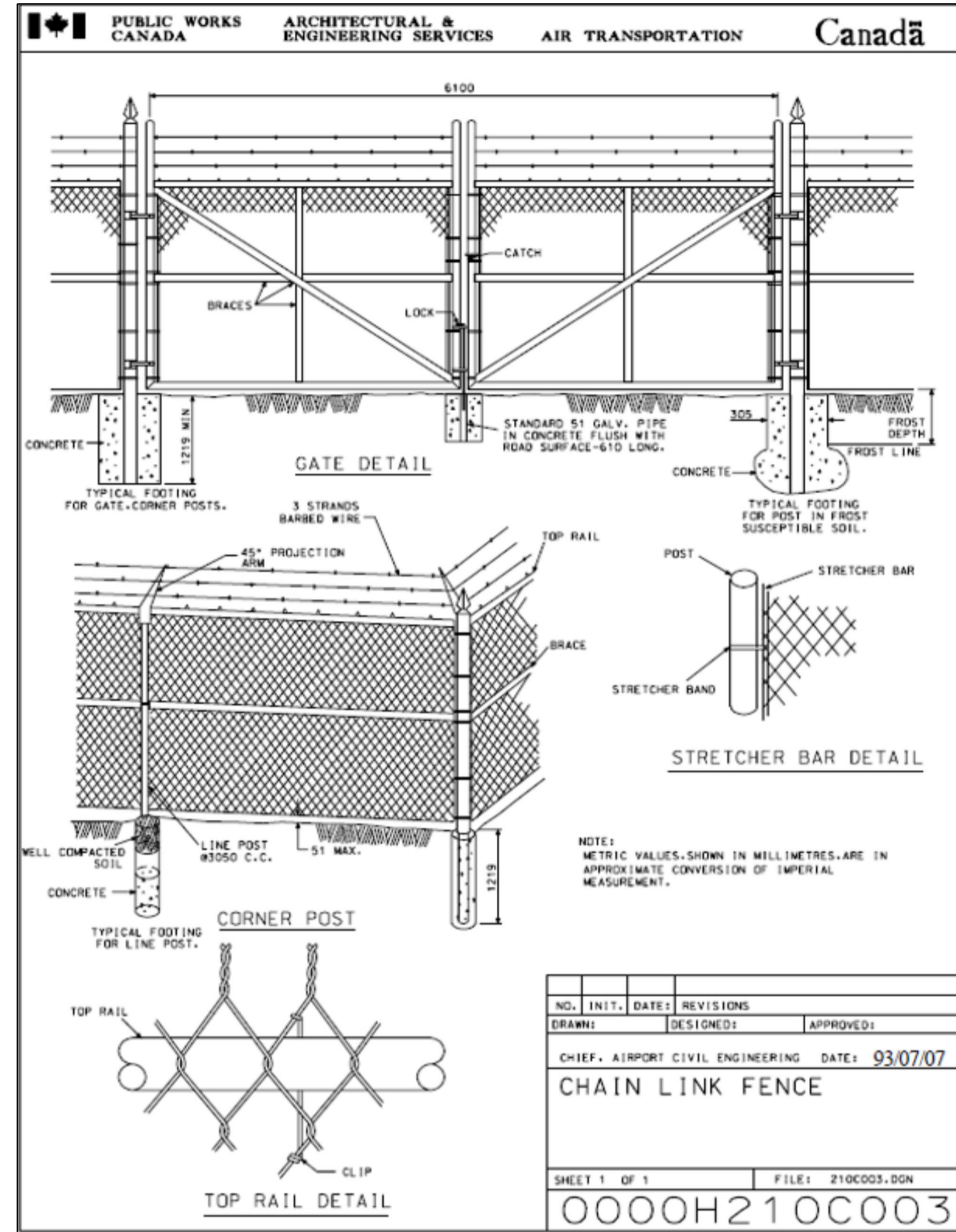

6 CULVERT RIPRAP DETAIL
SCALE N/A

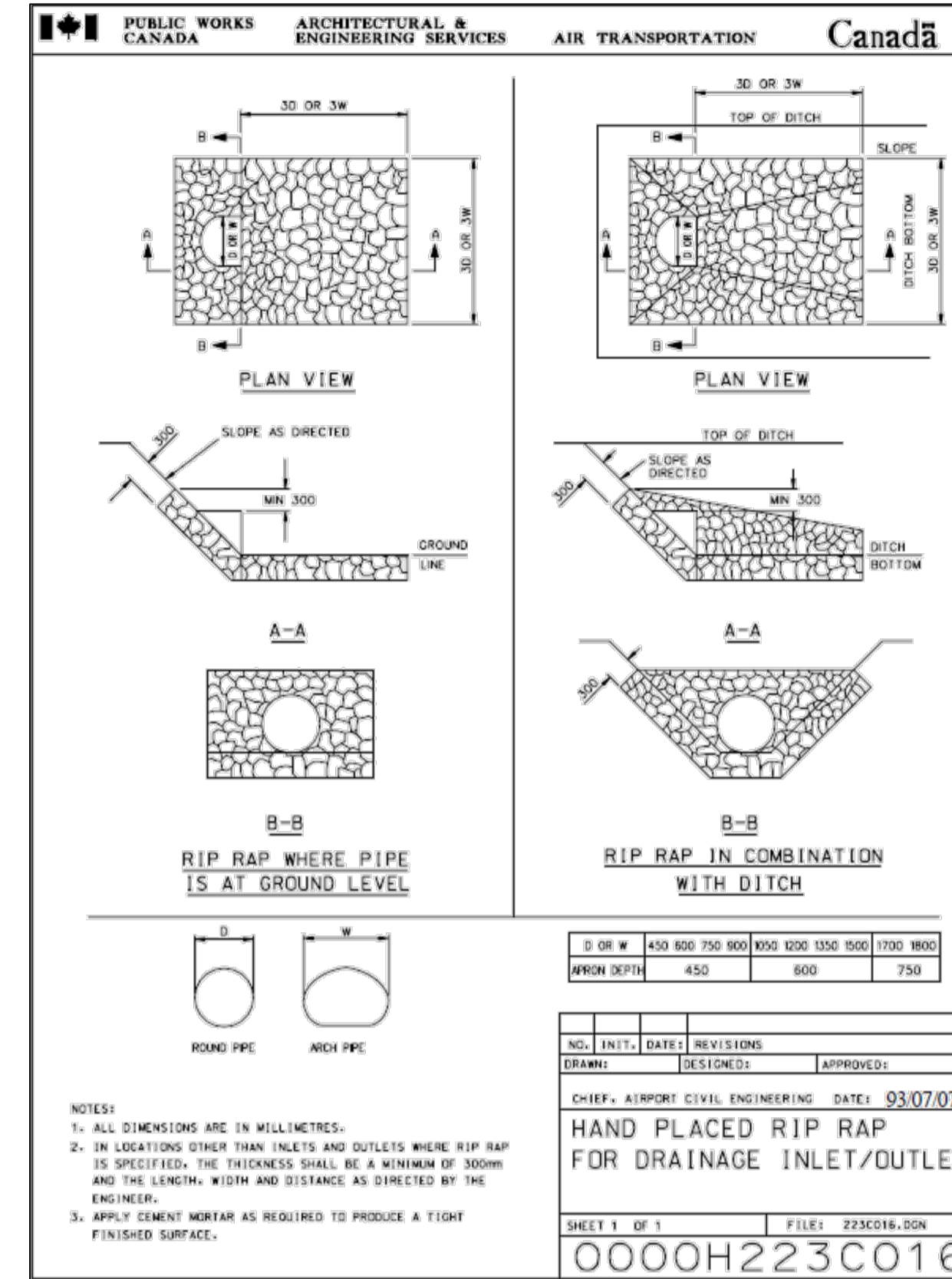

7 HYDRANT DETAIL
SCALE N/A

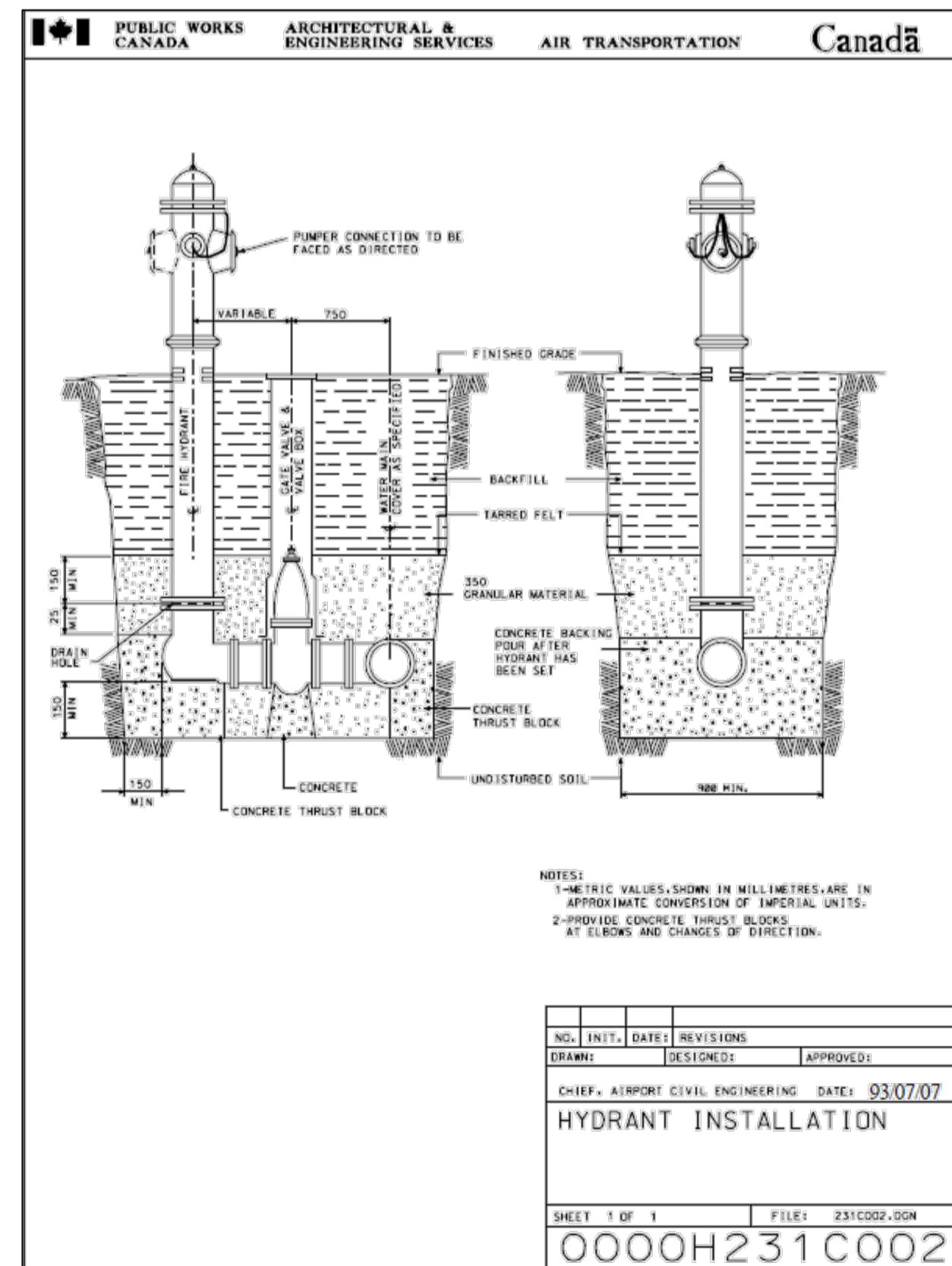

8 SANITARY PUMPING STATION ELECTRICAL DETAIL
SCALE N/A

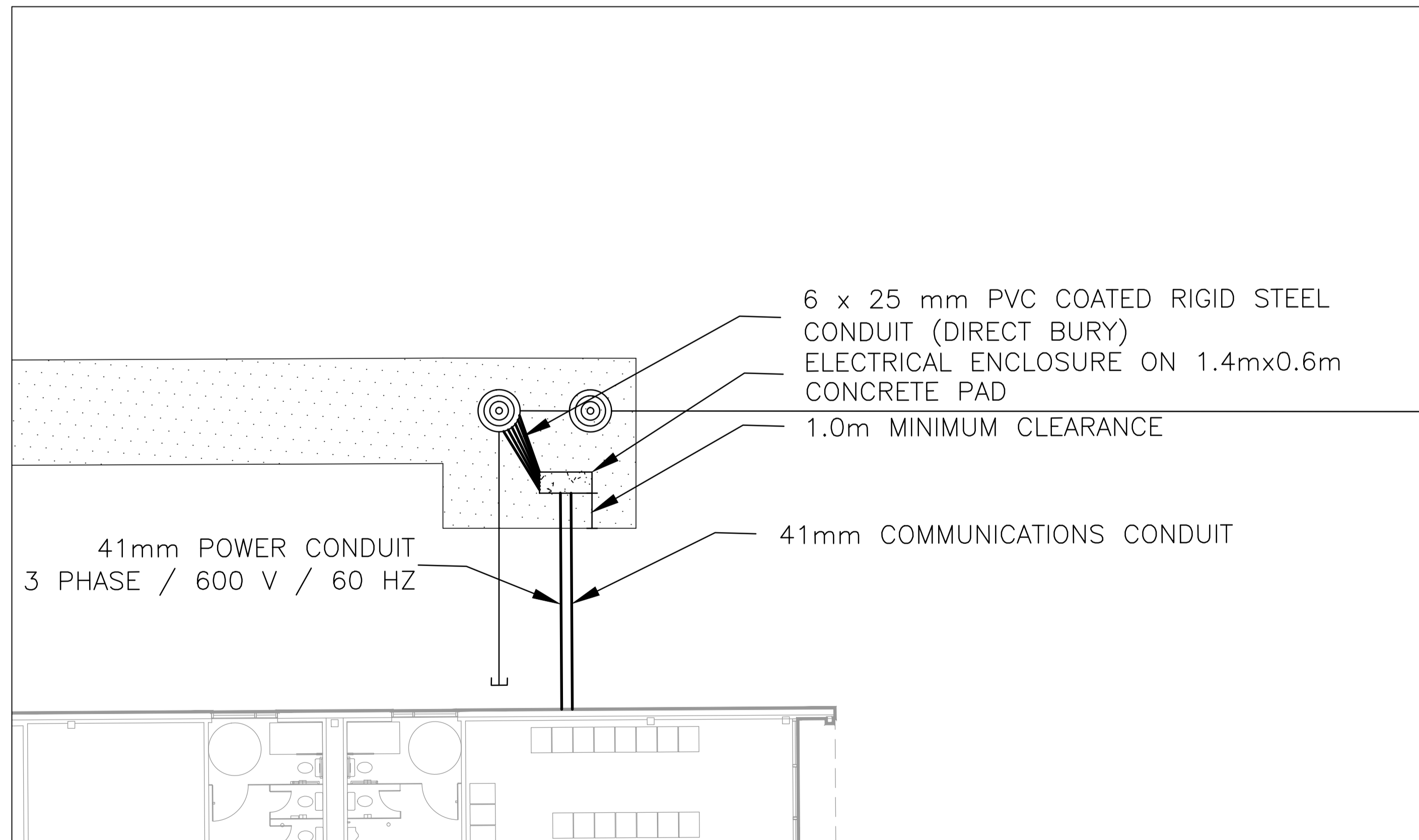

GENERAL NOTES

- SEE DRAWING A103 AND A104 FOR DETAILS AND NOTES



- Verify all dimensions and site conditions and be responsible for same
- Vérifier toutes les dimensions et l'état des lieux et en assumer la responsabilité

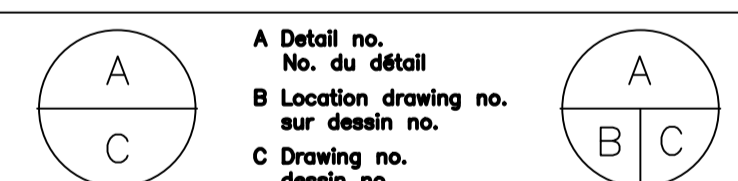

project	NRC U72			project
RESEARCH ROAD				
OTTAWA, ON				
drawing	DETAILS DRAWING 2			dessin
designed	conçu	date	date	
KW / LPL		JUN 2016		
drawn	dessiné	scale	échelle	
LPL		1:250		
checked	vérifié	sheet	feuille	
KW		4 of/de 4		
approved	approuvé	W.O.no.	D.T.no.	
KW		----		
dwg.no.				dessin no.
A103				



GENERAL NOTES

SEE DRAWING A103 AND A104 FOR DETAILS AND NOTES

ISSUED FOR 50% REVIEW 15/06/2016

Ainley
 2724 Fenton Road
 Ottawa, Ontario
 K1T 3T7
 Telephone: (613) 822-1052
 Fax: (613) 822-1573

Verify all dimensions and site conditions and be responsible for same
 Vérifier toutes les dimensions et l'état des lieux et en assumer la responsabilité

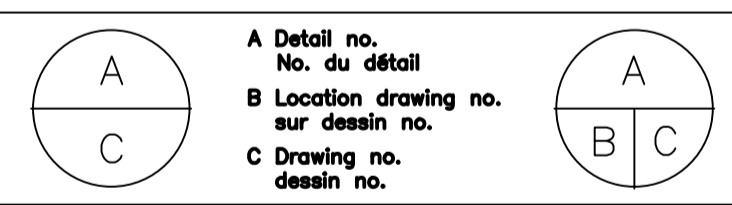

project **NRC U72** project
RESEARCH ROAD
OTTAWA, ON
 drawing **REMOVAL PLAN** dessin

designed	conçu	date	date
KW / LPL		JUN 2016	
drawn	dessiné	scale	échelle
LPL		1:250	
checked	vérifié	sheet	feuille
KW		2 of/ de 4	
approved	approuvé	W.O.no.	D.T.no.
KW		---	
dwg.no.			dessin no.
A101			

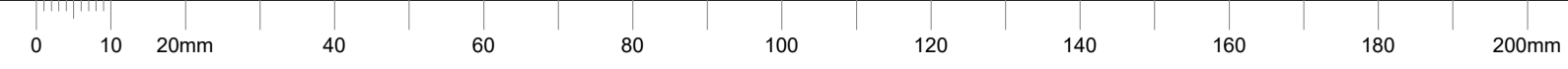
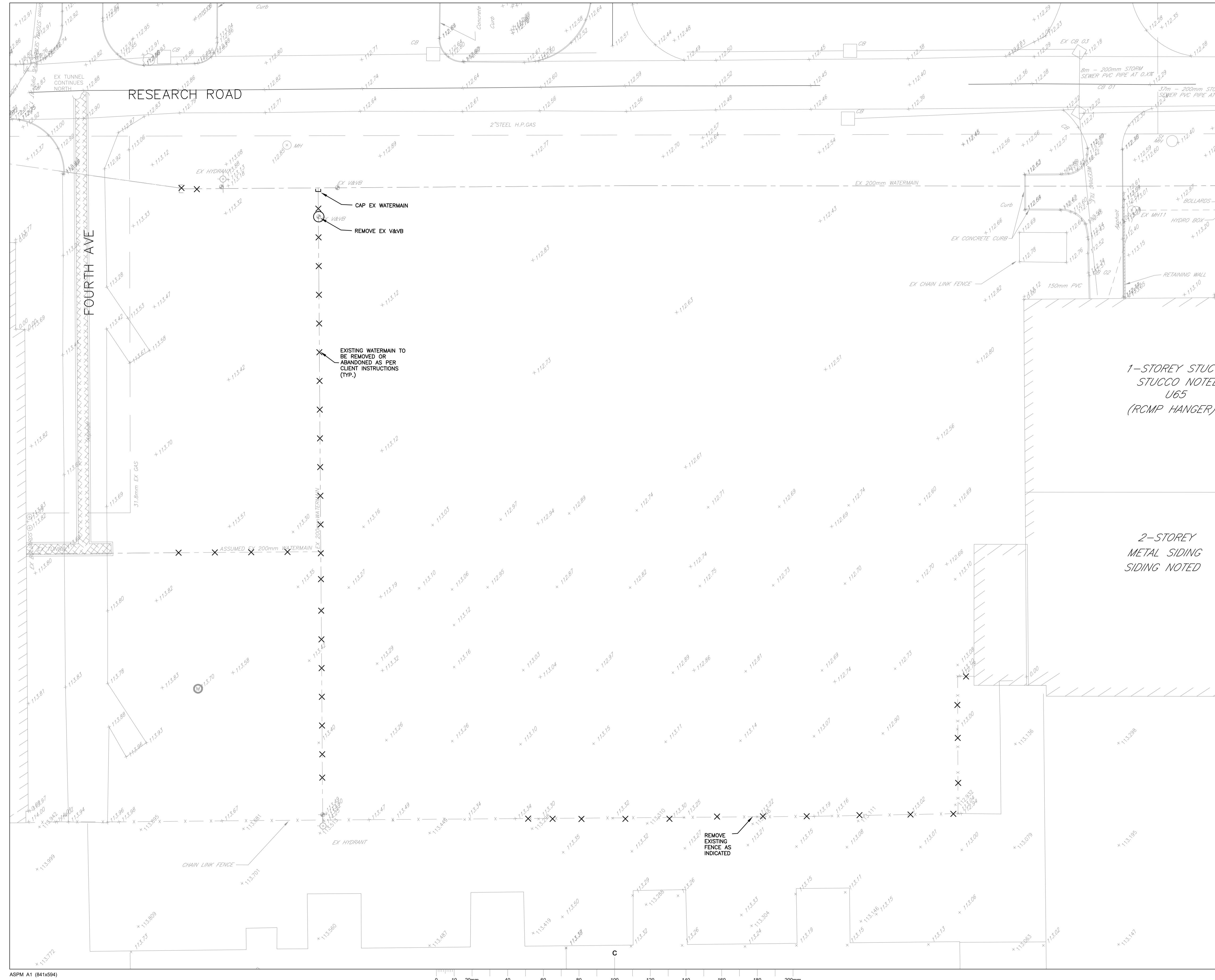



GENERAL NOTES:

- ALL FOOTINGS SHALL BEAR ON ORIGINAL UNDISTURBED SOIL, WITH A BEARING CAPACITY OF 100 kPa.
 - BACKFILL SHALL BE GRADED CRUSHED STONE COMPACTED TO 95% MODIFIED PROCTOR DRY DENSITY.
- CONCRETE:**
- CONCRETE SHALL HAVE A 28-DAY COMPRESSIVE STRENGTH OF 25 MPa.
 - REINFORCING STEEL SHALL CONFORM TO CSA G30.18-09, GRADE 400.
 - THE CONTRACTOR SHALL TAKE THREE CONCRETE COMPRESSION TEST CYLINDERS FOR EACH CONCRETE POUR. ONE SHALL BE TESTED AT 7 DAYS AND TWO AT 28 DAYS.
 - CONCRETE COVER TO REINFORCING STEEL
 - FOOTINGS 75mm
 - WALLS 50mm
 - THE CONTRACTOR SHALL SUBMIT FOR REVIEW SHOP DRAWINGS AND BAR LISTS FOR THE REINFORCING STEEL.
 - THE CONCRETE FLOOR SLAB SHALL RECEIVE A STEEL-TROWELED FINISH, AND SHALL BE WATER-CURED FOR A PERIOD OF 7 DAYS. THE SLAB SHALL BE SAW-CUT INTO PANELS NOT EXCEEDING 8.0 m x 8.0 m, 48 HOURS AFTER SLAB IS POURED.
 - ALL CONCRETE WORK SHALL CONFORM TO CSA A23.1-04 AND CSA A23.2-04.

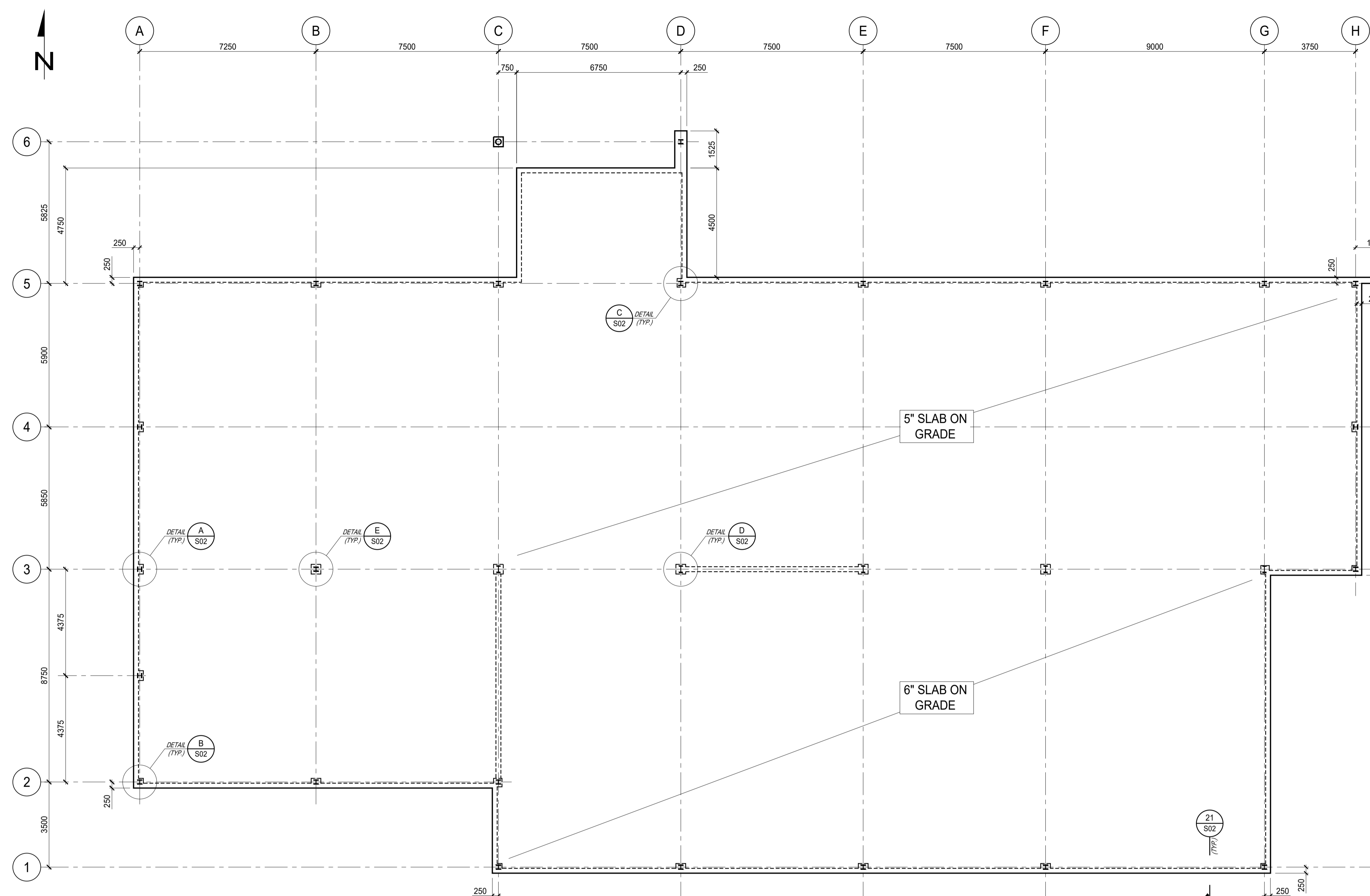

FOUNDATION / GROUND FLOOR PLAN
 SCALE = 1:100

PRELIMINARY

No.	Date	Revision	By:	Par:
1	JUN 15/16	50% COMPLETE DRAWING	R.L.	
0	MAR 15/16	PRELIMINARY	R.L.	

- Verify all dimensions and site conditions and be responsible for same.
- Vérifier toutes les dimensions et l'état des lieux et en assumer la responsabilité.

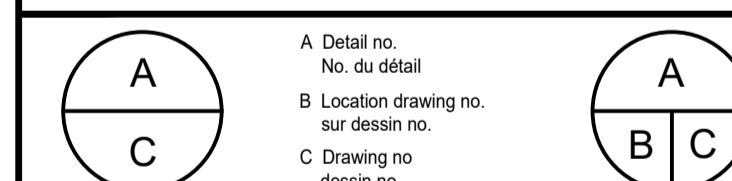

project projet

BUILDING U-72
 UPLANDS CAMPUS

drawing dessin
STRUCTURAL:
FOUNDATION PLAN

designed conçu	date date
R.L.	FEBRUARY, 2016

drawn dessiné	scale échelle
D.M.D./A.A.	AS SHOWN

checked vérifié	sheet feuille
R.L.	S01 of S04

approved approuvé	W.O.no. D.T.no.

dwg no. dessin no.
0000-S01

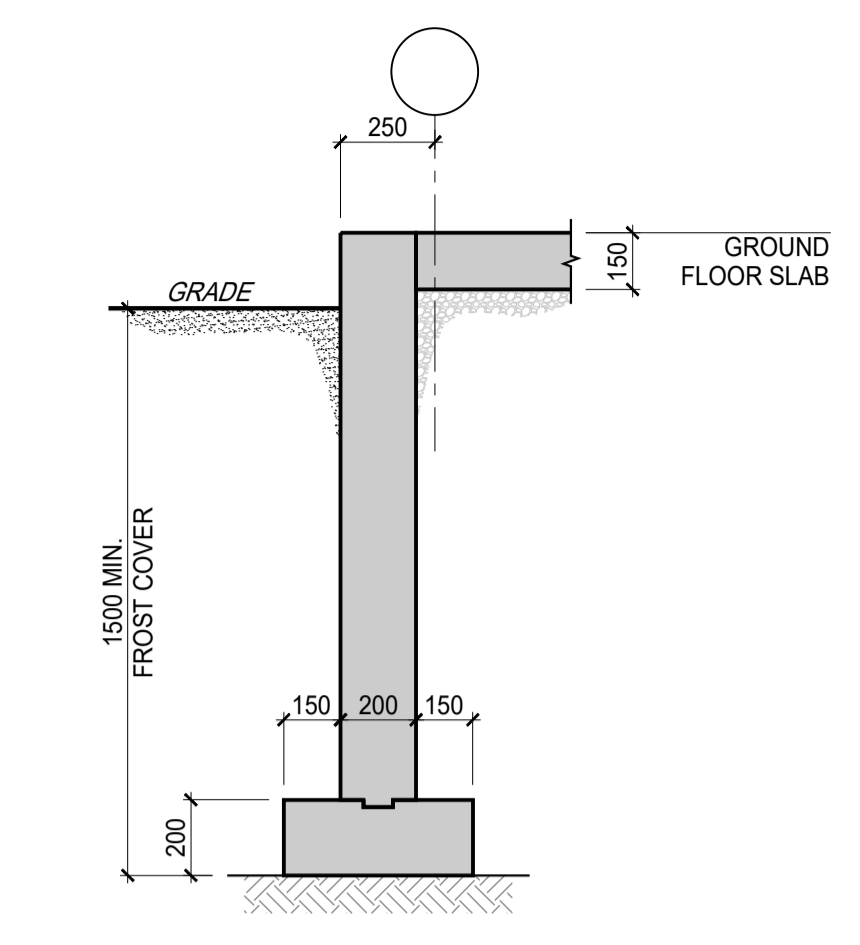
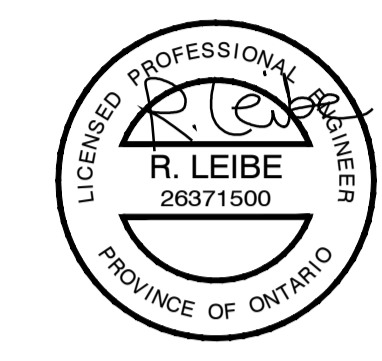

21 SECTION (TYPICAL UNLESS NOTED)
 S02 SCALE = 1:20

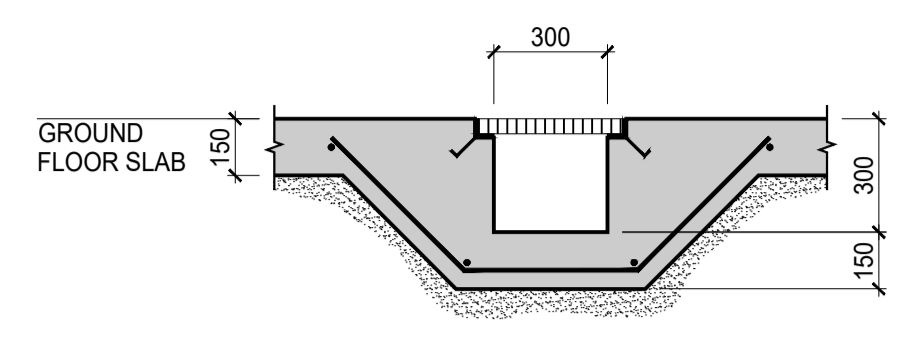

22 SECTION (TYPICAL TRENCH DRAIN)
 S02 SCALE = 1:20

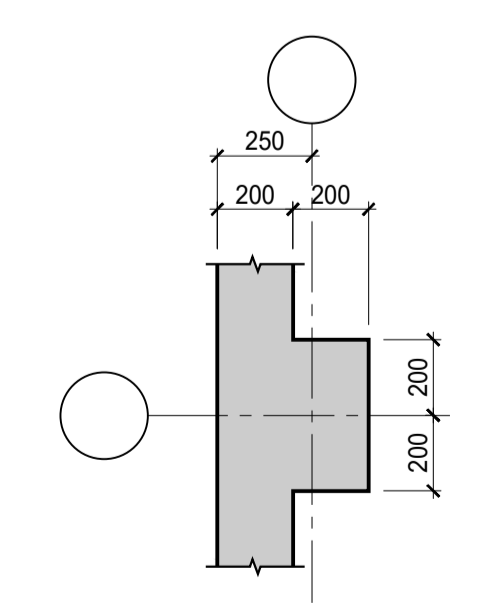

A DETAIL
 S02 SCALE = 1:20

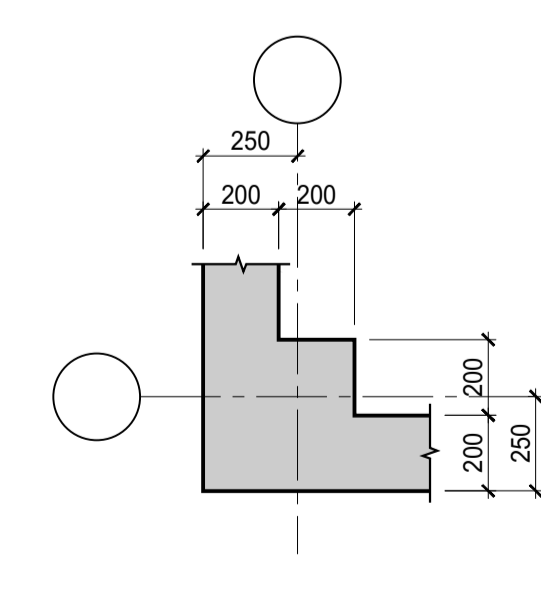

B DETAIL
 S02 SCALE = 1:20

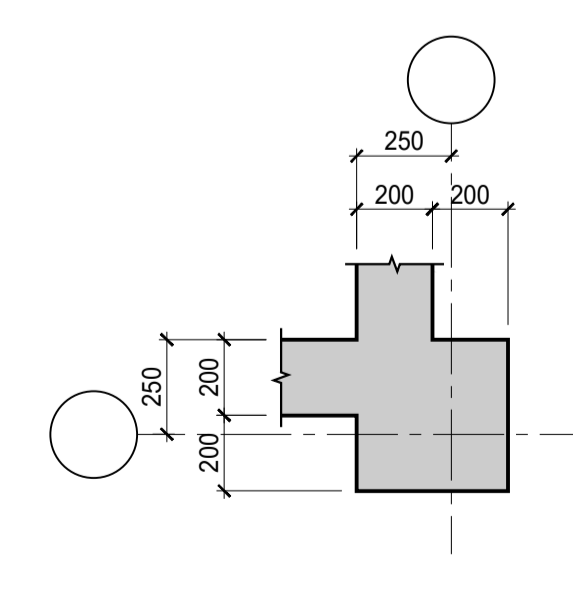

C DETAIL
 S02 SCALE = 1:20

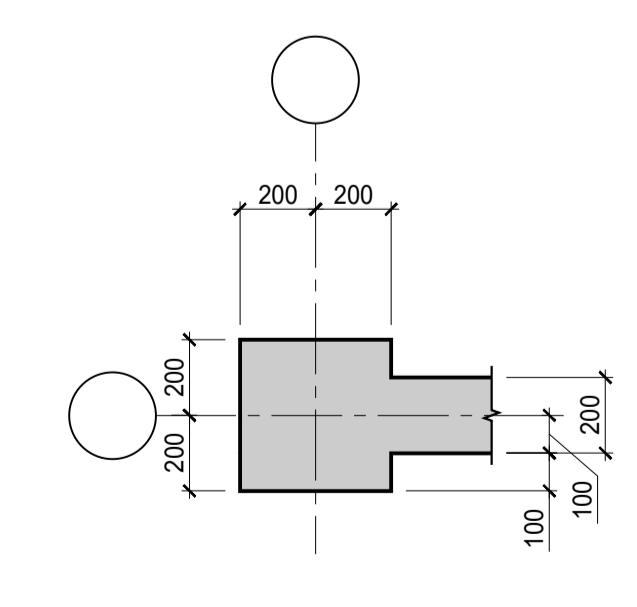

D DETAIL
 S02 SCALE = 1:20

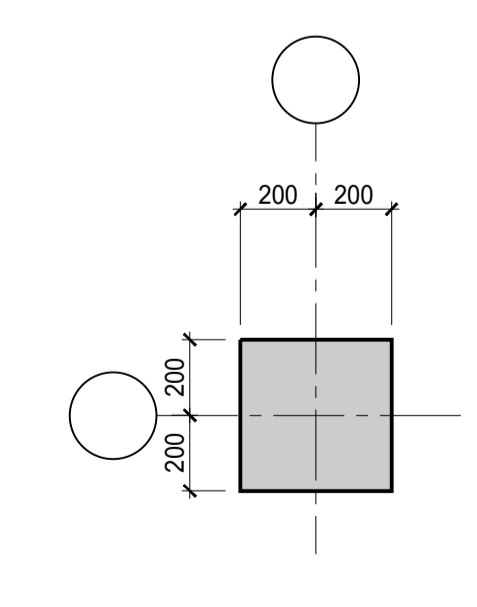

E DETAIL
 S02 SCALE = 1:20

PRELIMINARY

No.	Date	Revision	By:
0	MAR 15/16	PRELIMINARY	R.L.

- Verify all dimensions and site conditions and be responsible for same.
- Vérifier toutes les dimensions et l'état des lieux et en assumer la responsabilité.

A C	A Detail no. No. du détail B Location drawing no. sur dessin no. C Drawing no. dessin no.	A B C
--------	--	----------

project / projet
BUILDING U-72
 UPLANDS CAMPUS

drawing / dessin
**STRUCTURAL:
 CONCRETE DETAILS**

designed / conçu	R.L.	date / date	FEBRUARY, 2016
drawn / dessiné	D.M.D.	scale / échelle	AS SHOWN
checked / vérifié	R.L.	sheet / feuille	S02 of / de S04
approved / approuvé		W.O.no.	D.T.no.

dwg no. / dessin no.
0000-S02

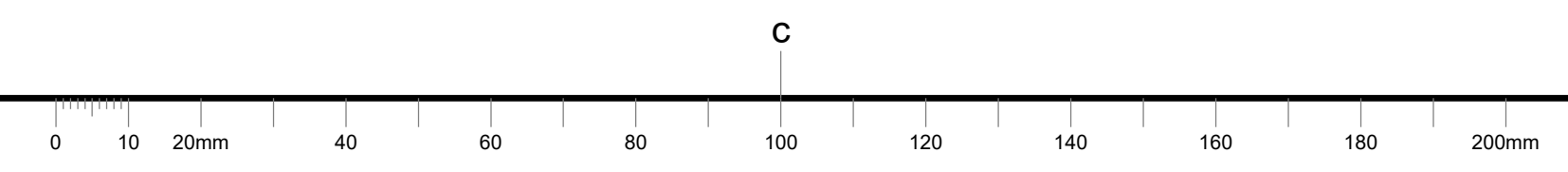

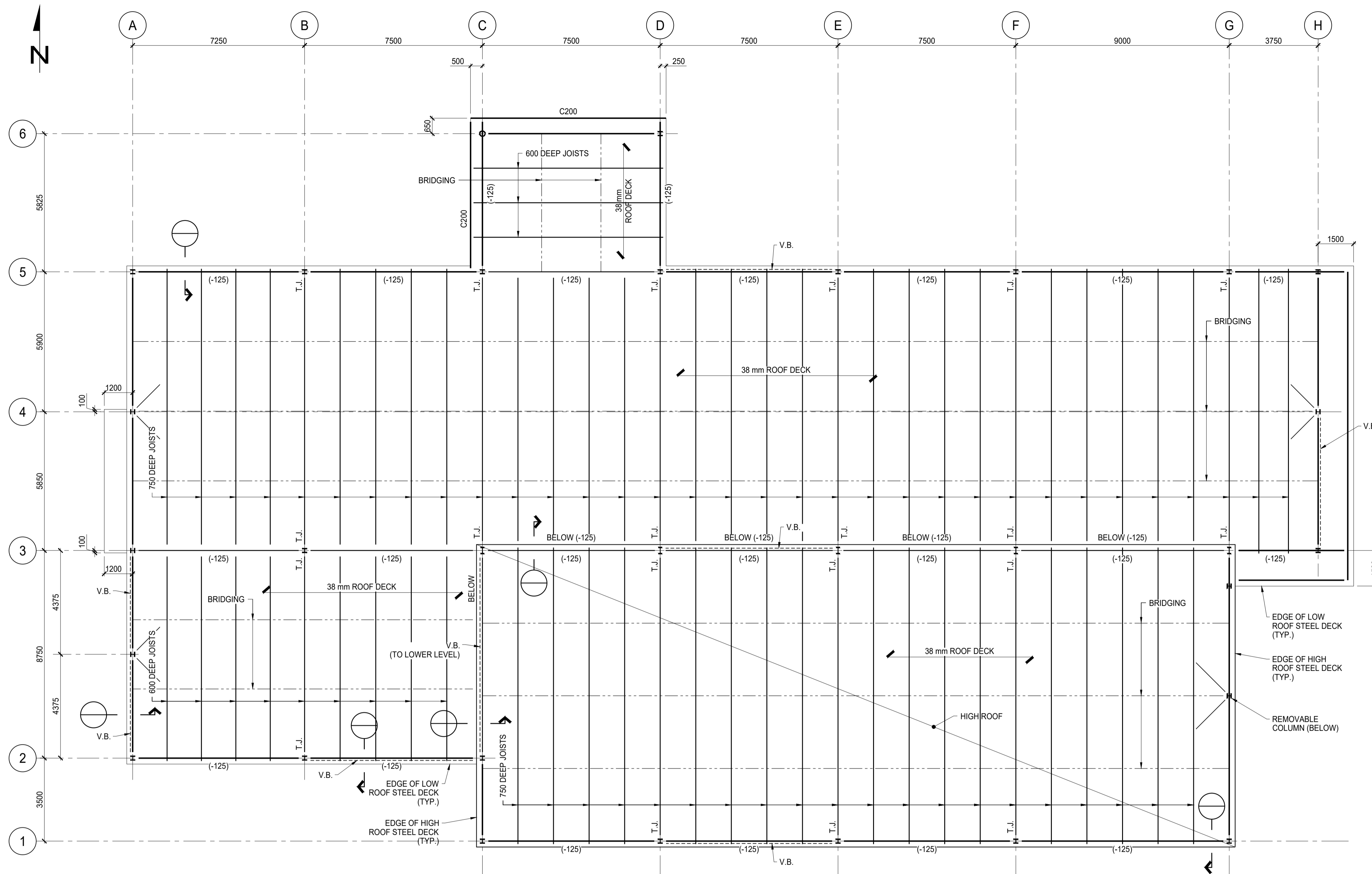

GENERAL NOTES:

STRUCTURAL STEEL:

- ALL STRUCTURAL STEEL SHALL CONFORM TO CSA G40.20-04 AND CSA G40.21-04, GRADE 350.
- ALL STRUCTURAL STEEL SHALL RECEIVE TWO SHOP COATS OF PRIMER CONFORMING TO CAN/CSB 1-40.97, "ANTI-CORROSIVE STRUCTURAL STEEL ALKYD PRIMER."
- ALL WELDING MATERIALS SHALL CONFORM TO CSA W48.06.
- WELDING SHALL CONFORM TO CSA W59-03 (R2008) AND SHALL BE CARRIED OUT BY WELDERS QUALIFIED BY THE CANADIAN WELDING BUREAU.
- ALL BOLTS SHALL BE 20mm DIA. HIGH TENSILE BOLTS CONFORMING TO ASTM F3125, GRADE A325.
- THE CONTRACTOR SHALL SUBMIT FOR REVIEW SHOP DRAWINGS FOR REVIEW, INCLUDING ERECTION AND SHOP DETAIL DRAWINGS, BEFORE THE START OF FABRICATION.
- THE STEEL CONTRACTOR SHALL VERIFY DIMENSIONS ON SITE BEFORE THE START OF FABRICATION. NOTIFY ENGINEER OF ANY DISCREPANCIES.
- ALL STRUCTURAL STEEL WORK SHALL CONFORM TO CSA S16-14.



Leibe Engineering Associates
 Consulting Engineers / Ingenieurs-Consuls
 22 Antares Drive, Suite 201
 Ottawa, Ontario, K2E 7Z6
 tel: (613) 723-7765 fax: (613) 723-0095



PRELIMINARY

ROOF PLAN
 SCALE = 1:100

- V.B. = VERTICAL BRACING
- DESIGN LOADS:
 - LIVE: 1.44 kPa (30 lbs/sq.ft.)
 - DEAD: 2.30 kPa (48 lbs/sq.ft.)

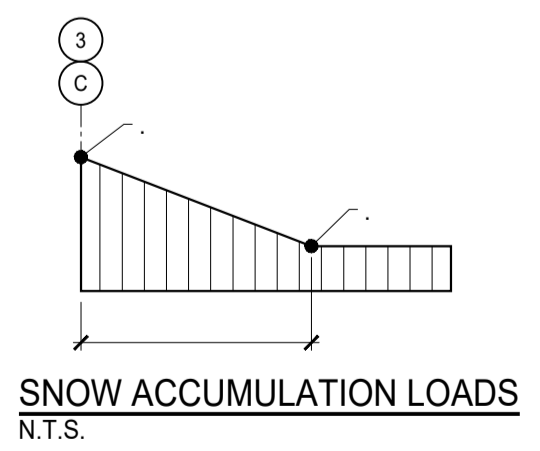

No.	Date	Revision	By:
1	JUN 15/16	50% COMPLETE DRAWING	R.L.
0	MAR 15/16	PRELIMINARY	R.L.

- Verify all dimensions and site conditions and be responsible for same.
- Vérifier toutes les dimensions et l'état des lieux et en assumer la responsabilité.

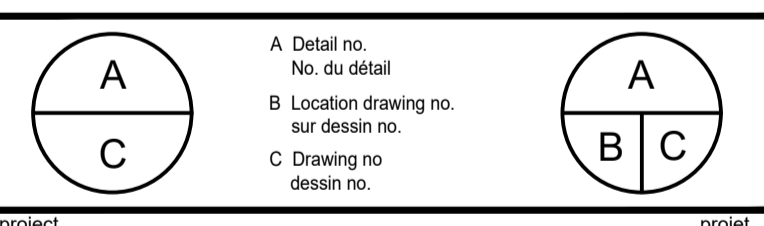

project: **BUILDING U-72**
 UPLANDS CAMPUS

drawing: **STRUCTURAL: ROOF PLAN**

designed	conçu	date	date
R.L.		FEBRUARY, 2016	
drawn	dessiné	scale	échelle
D.M.D.		AS SHOWN	
checked	vérifié	sheet	feuille
R.L.		S03 of S04	
approved	approuvé	W.O.no.	D.T.no.

dwg no. **0000-S03** dessin no.

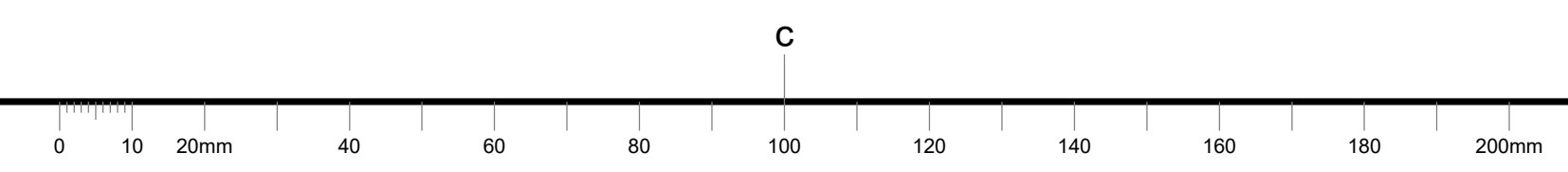

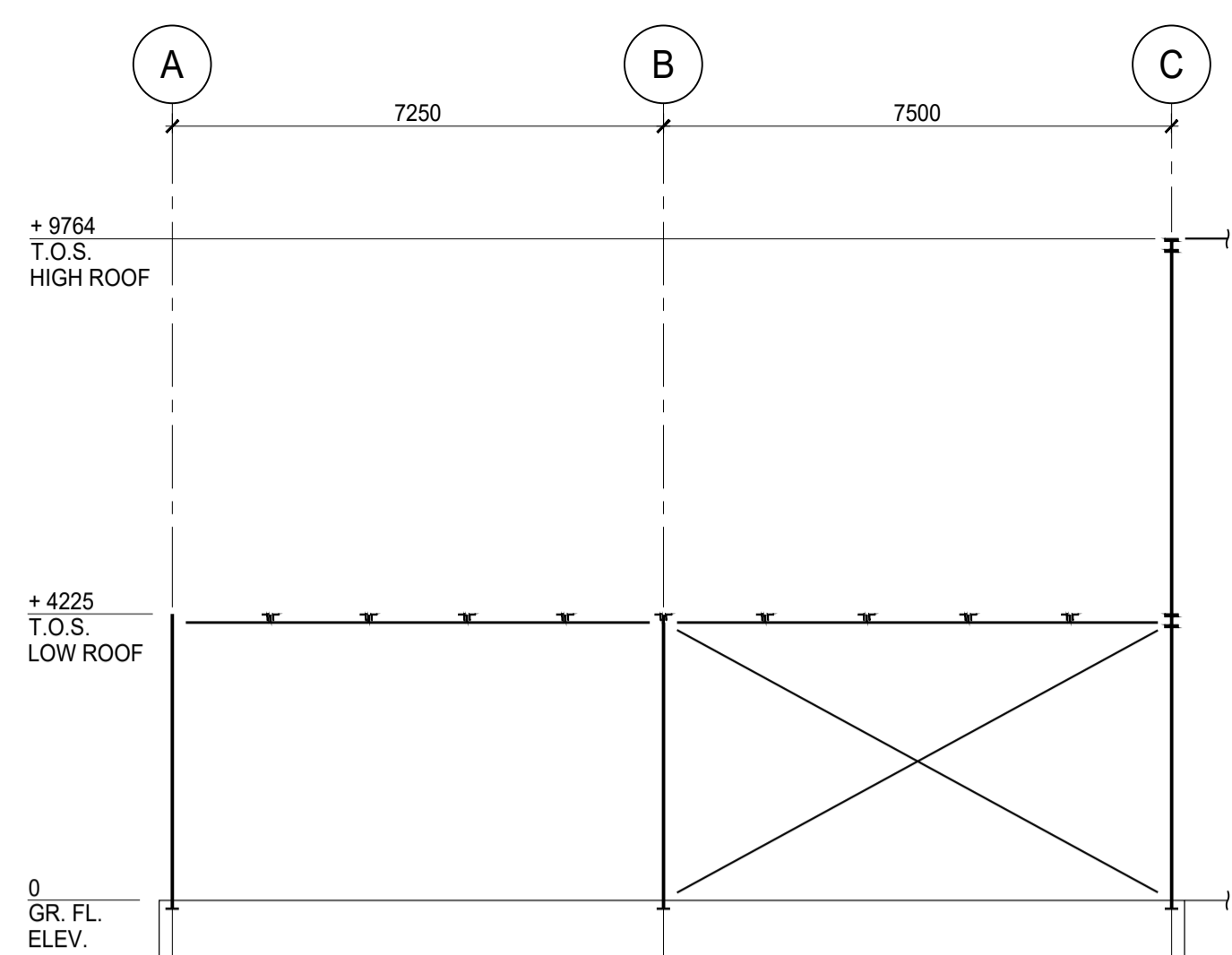

41 ELEVATION - GRID LINE 2
 S04 SCALE = 1:100

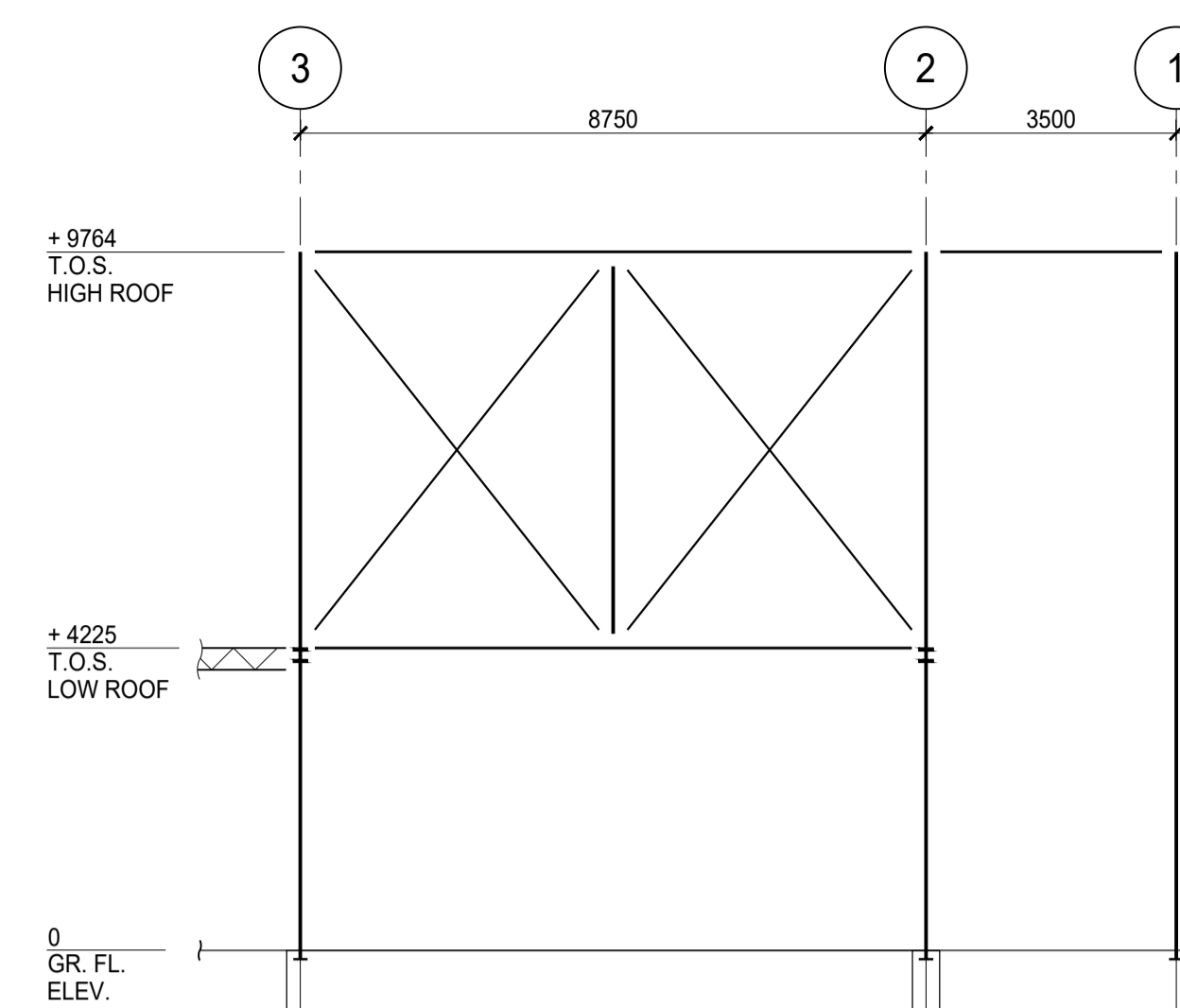

42 ELEVATION - GRID LINE C
 S04 SCALE = 1:100

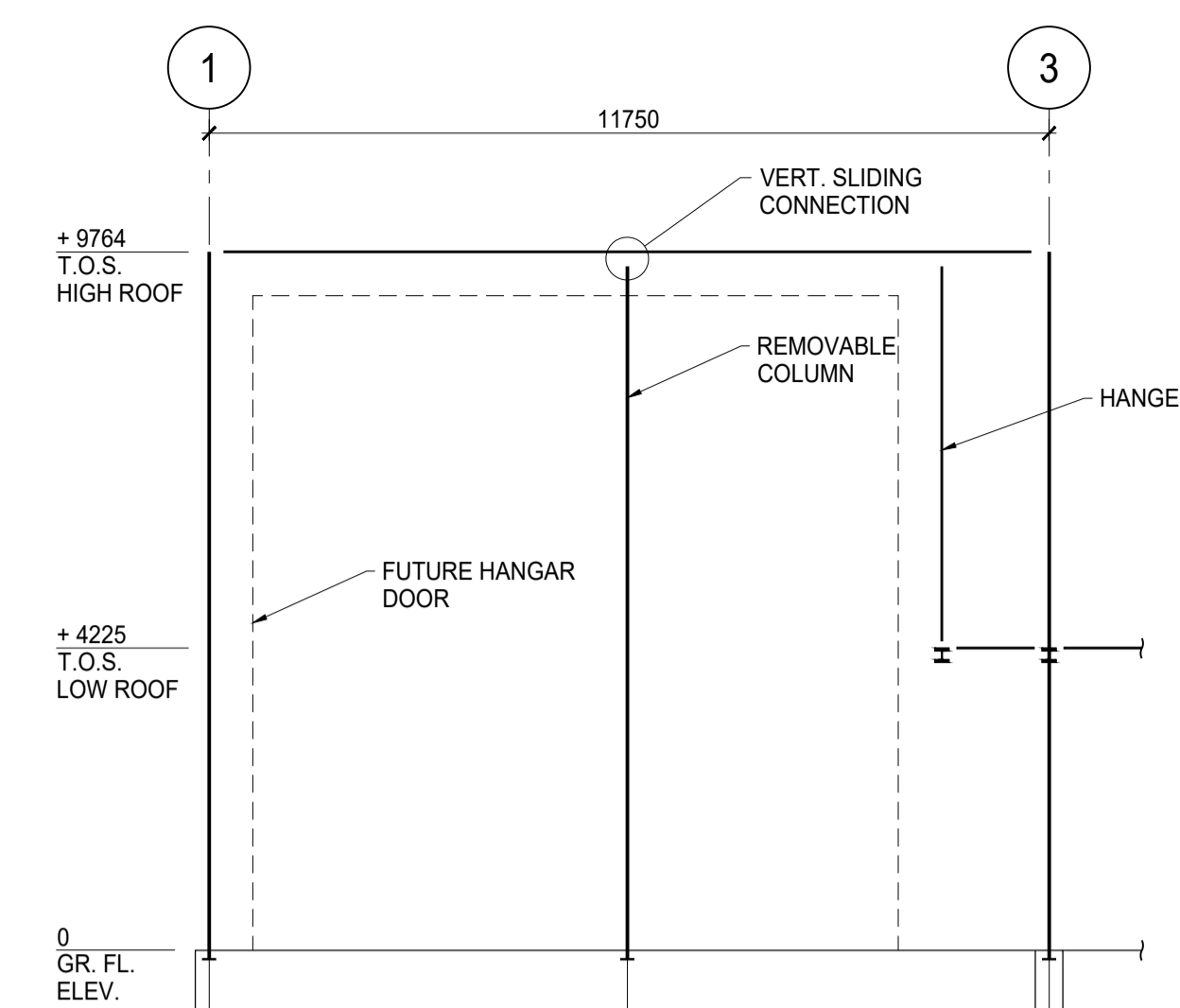

43 ELEVATION - GRID LINE G
 S04 SCALE = 1:100

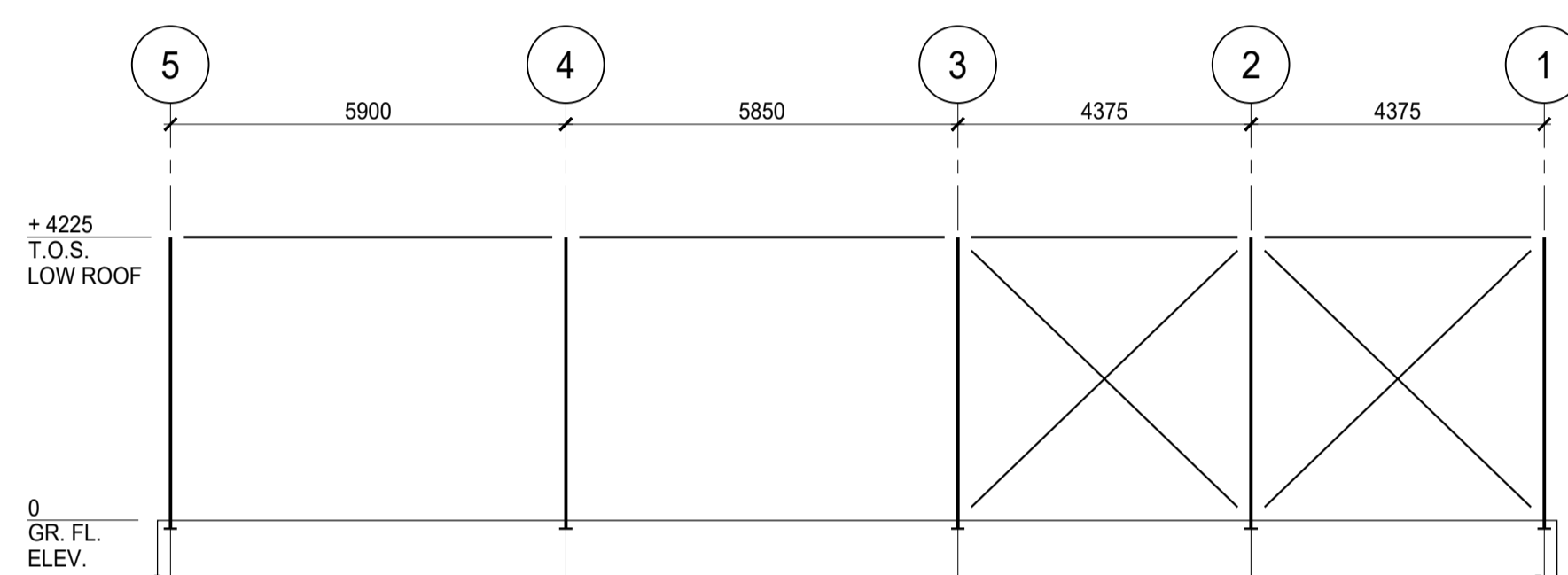

44 ELEVATION - GRID LINE A
 S04 SCALE = 1:100

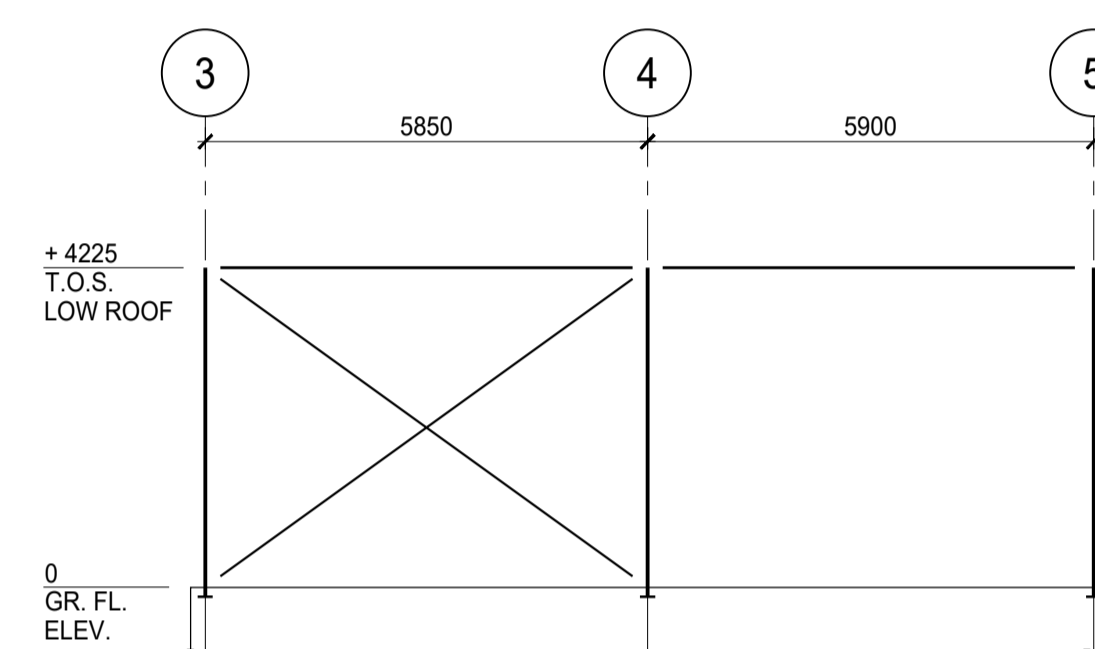

45 ELEVATION - GRID LINE H
 S04 SCALE = 1:100

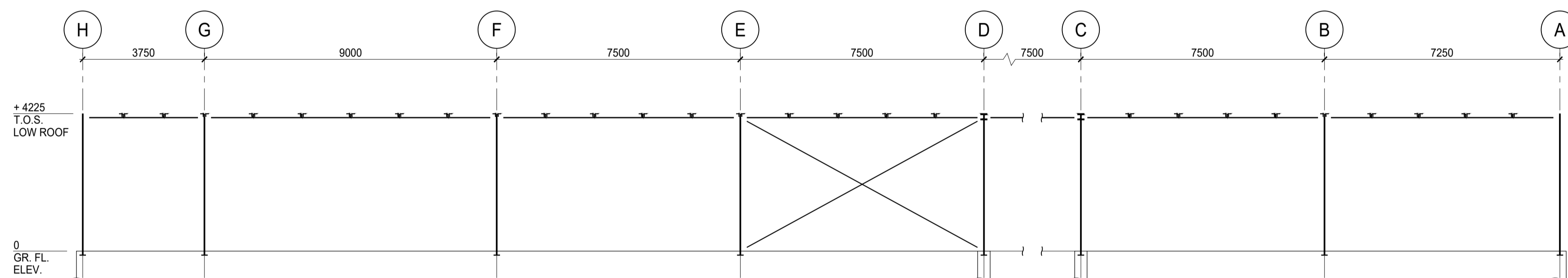

46 ELEVATION - GRID LINE 5
 S04 SCALE = 1:100

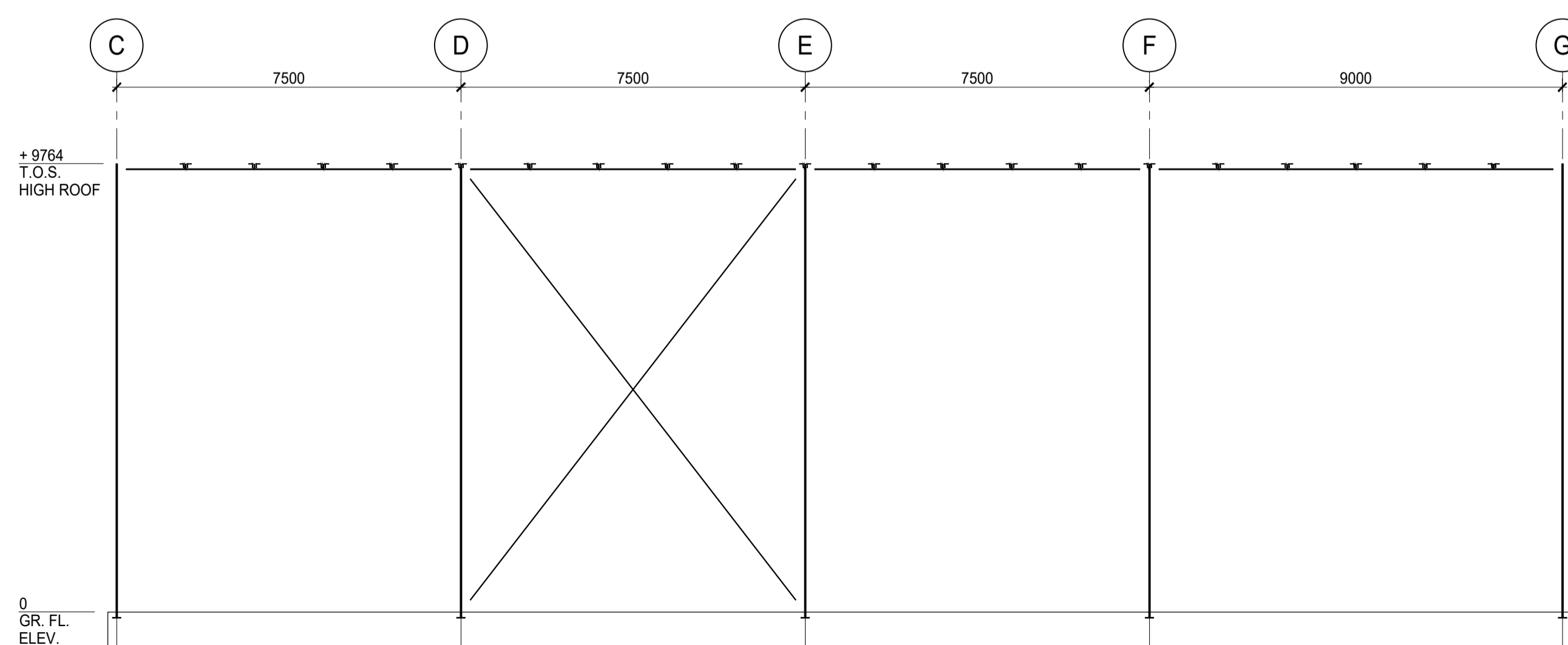

47 ELEVATION - GRID LINE 1
 S04 SCALE = 1:100

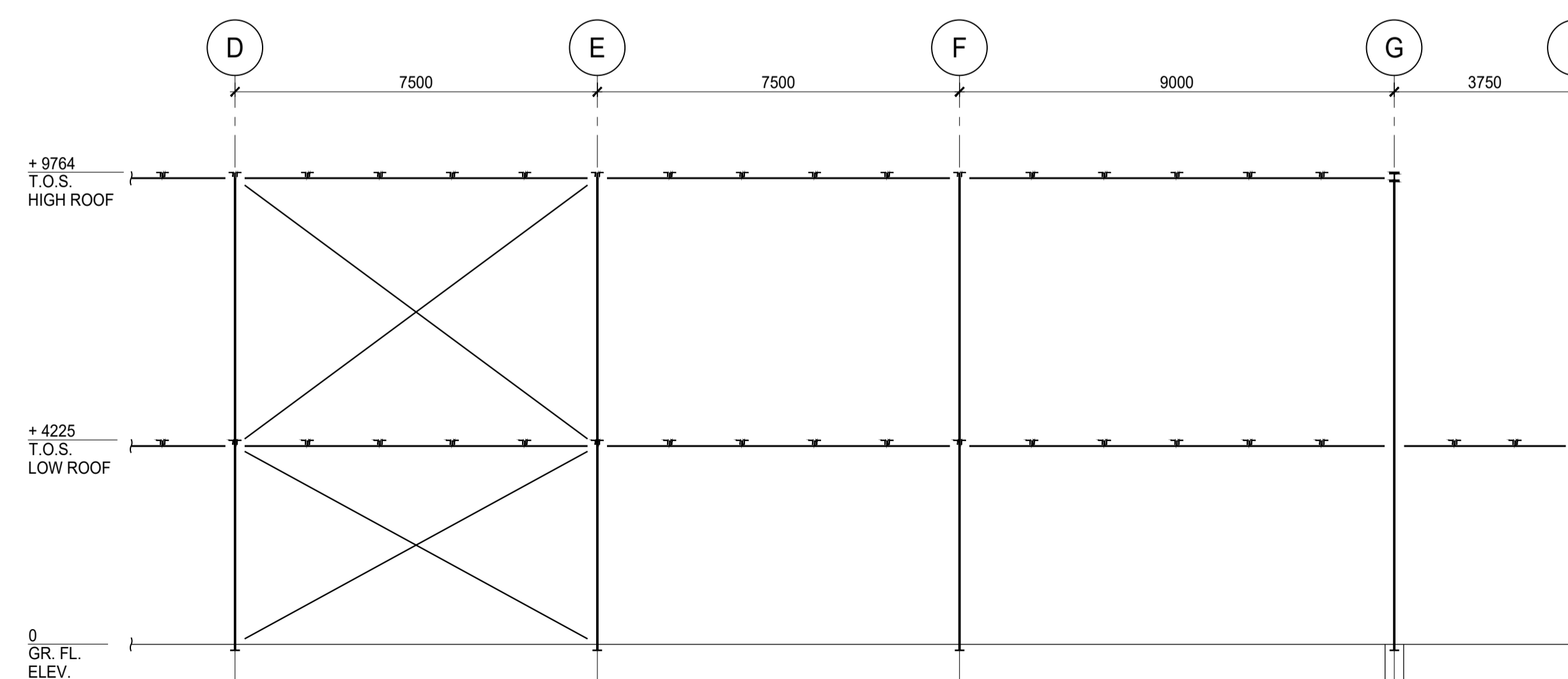

48 ELEVATION - GRID LINE 3
 S04 SCALE = 1:100

No.	Date	Revision	By:
1	JUN 15/16	50% COMPLETE DRAWING	R.L.
0	MAR 15/16	PRELIMINARY	R.L.

- Verify all dimensions and site conditions and be responsible for same.
- Vérifier toutes les dimensions et l'état des lieux et en assumer la responsabilité.

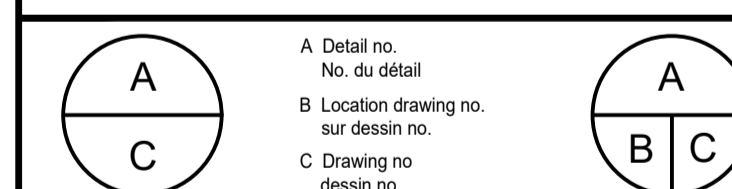

project		project	
BUILDING U-72			
UPLANDS CAMPUS			
drawing		dessin	
STRUCTURAL: WALL ELEVATIONS			
designed	conçu	date	date
R.L.		FEBRUARY, 2016	
drawn	dessiné	scale	échelle
A.A.		AS SHOWN	
checked	vérifié	sheet	feuille
R.L.		S04	of/de S04
approved	approuvé	W.O.no.	D.T.no.
dwg no.		dessin no.	
0000-S04			