

**Phase II Pressure Bays
(viewed from South)**

South-West

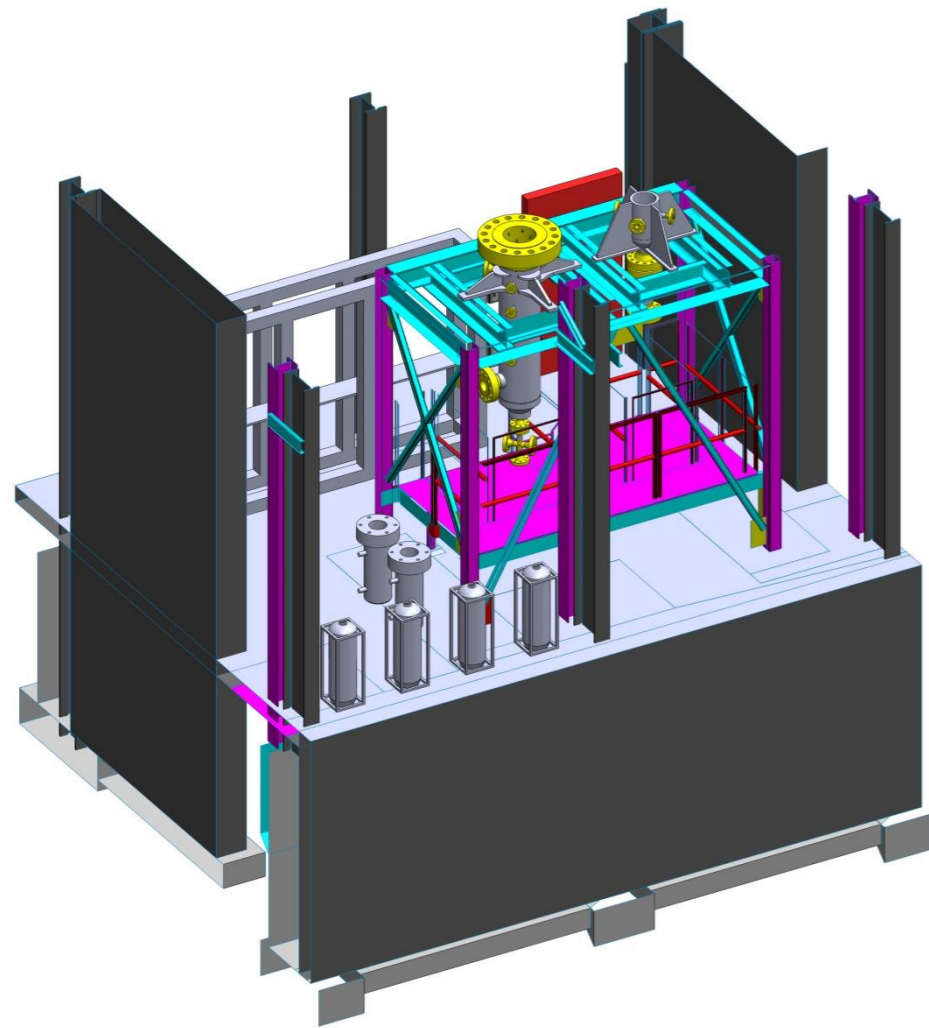

South

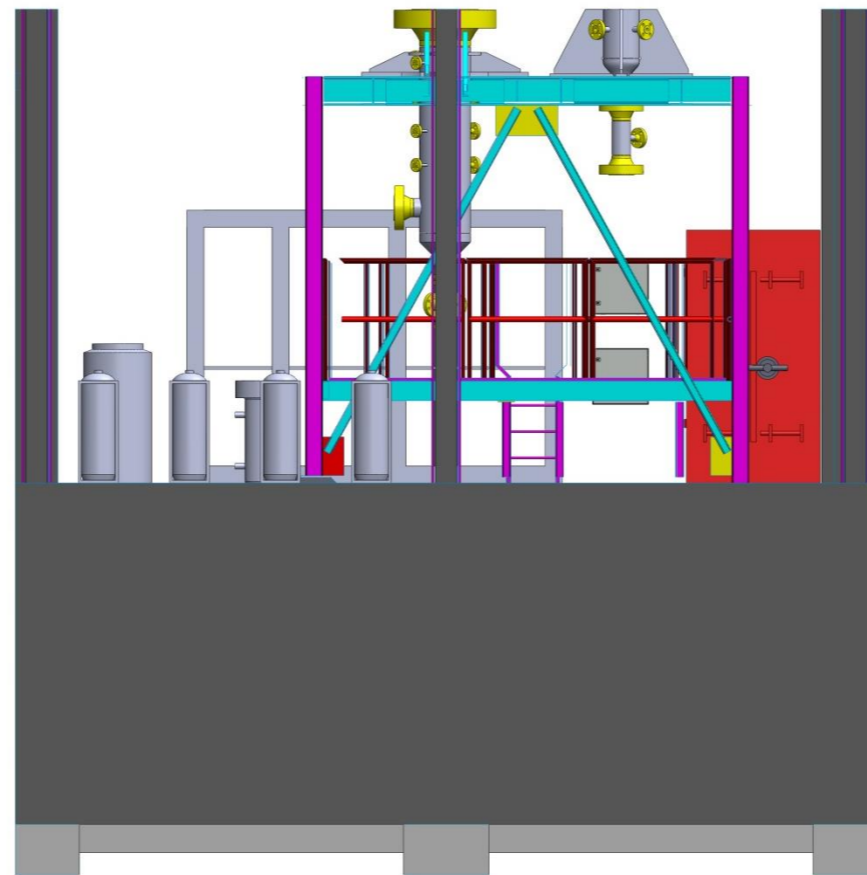

South-East

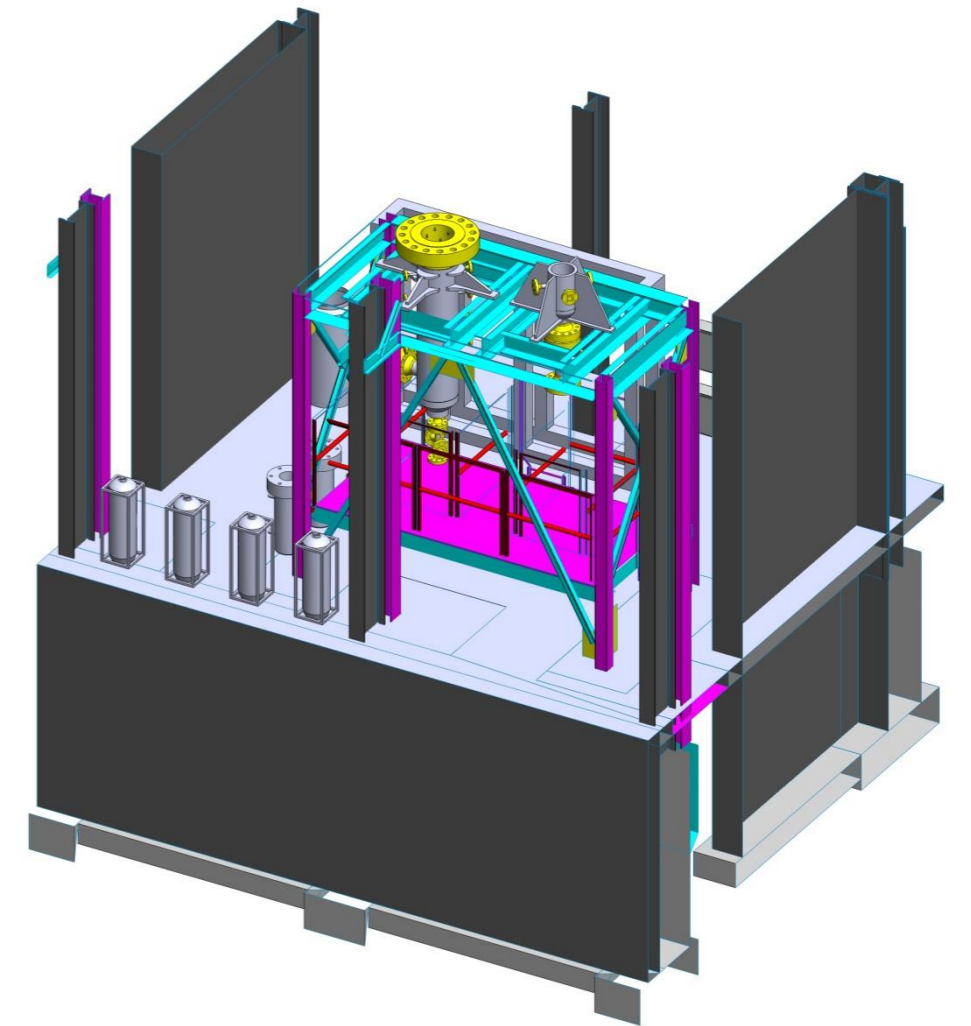

Room 115
(multiple views)



Liquid Sample System
(P&ID Sheet 5-03)

Activated Carbon Tank
(V-3402)

Scrubber Vessel Body
(V-3201)

Scrubber Liquid Sample
Heat Exchanger
(HX-3201)

Quench Liquid Sample
Heat Exchanger
(HX-3101)

Liquid Bag Filters
(F-3301 – F-3304)

TC Junction
115-2 (8 pt)

Solenoid Cabinets x2
(SC-115-1, SC-115-2)

Ash Handling Unit 2
(AH-3102),
Knife Gate Valves
(YV-3101, YV-3102)

TC Junction
115-1 (16pt)

**Room 115
(Top View)**

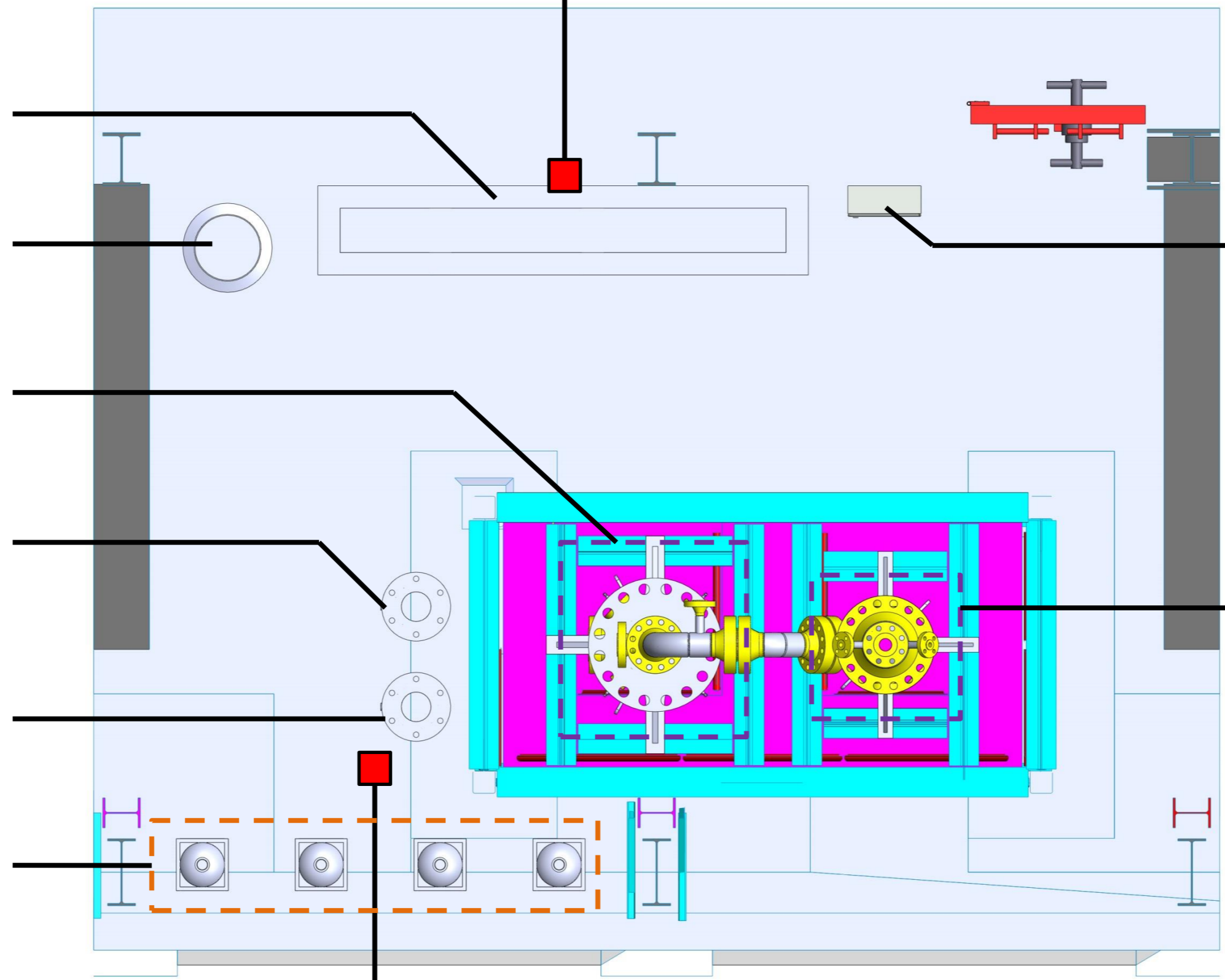

South-West

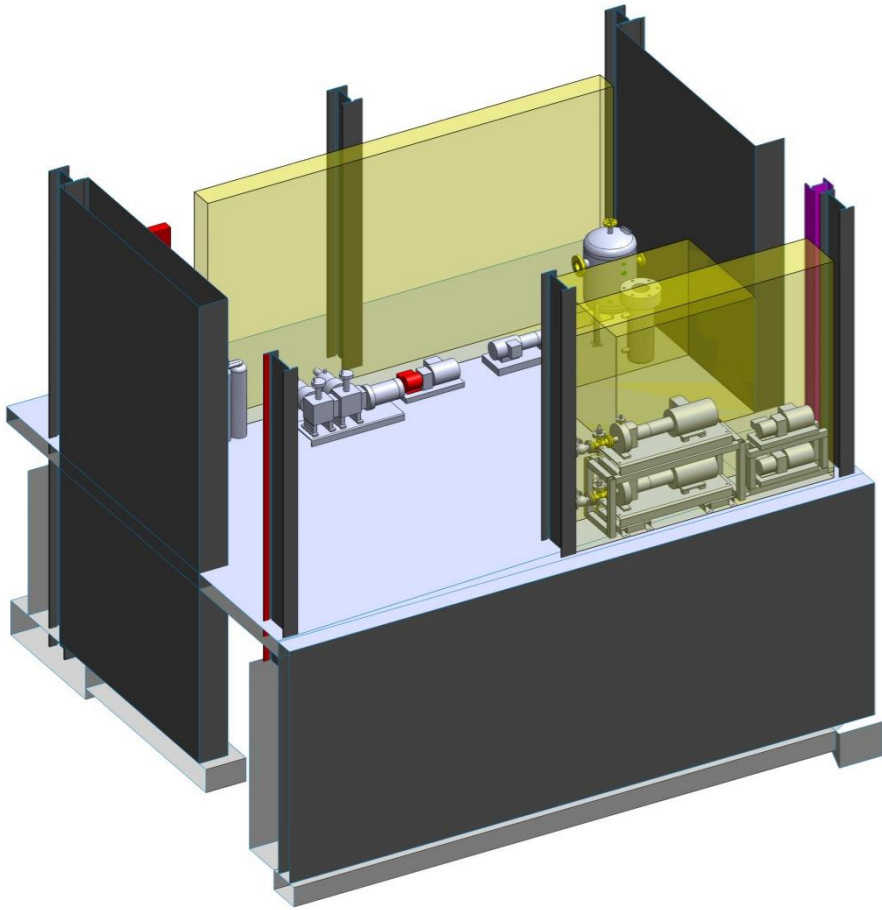

South



South-East

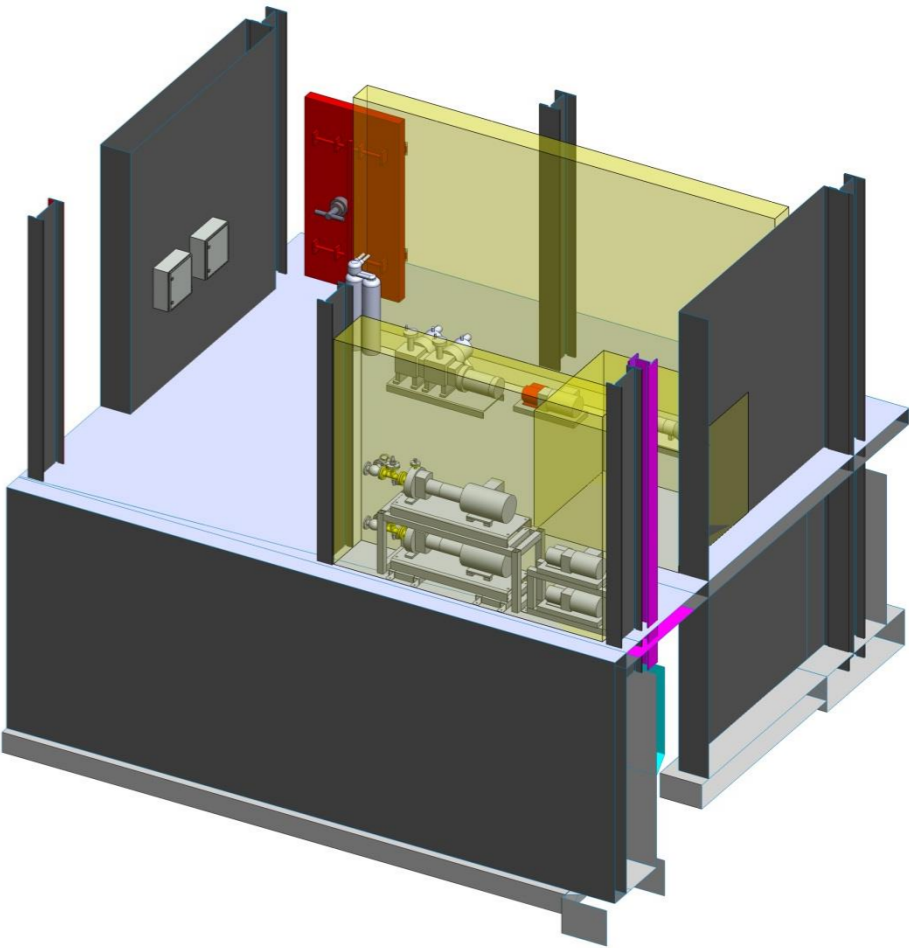

Room 116
(multiple views)



TC Junction
116-2 (8 pt)

LP/HP Water
Supply System;
excluding H-2601,
H-2602, H-2603
(P&ID Sheets 2-05, 2-06)

Water Recycle System
(P&ID Sheet 4-04)

Packaged Glycol System
(P&ID Sheet 4-05)

Liquid Fuel
Supply System
(P&ID Sheet 2-04)

PW/POW Supply System
(P&ID Sheet 1-06)

TC Junction
116-1 (8 pt)

**Room 116
(Top View)**

Solenoid Cabinets x2
(SC-116-1, SC-116-2)

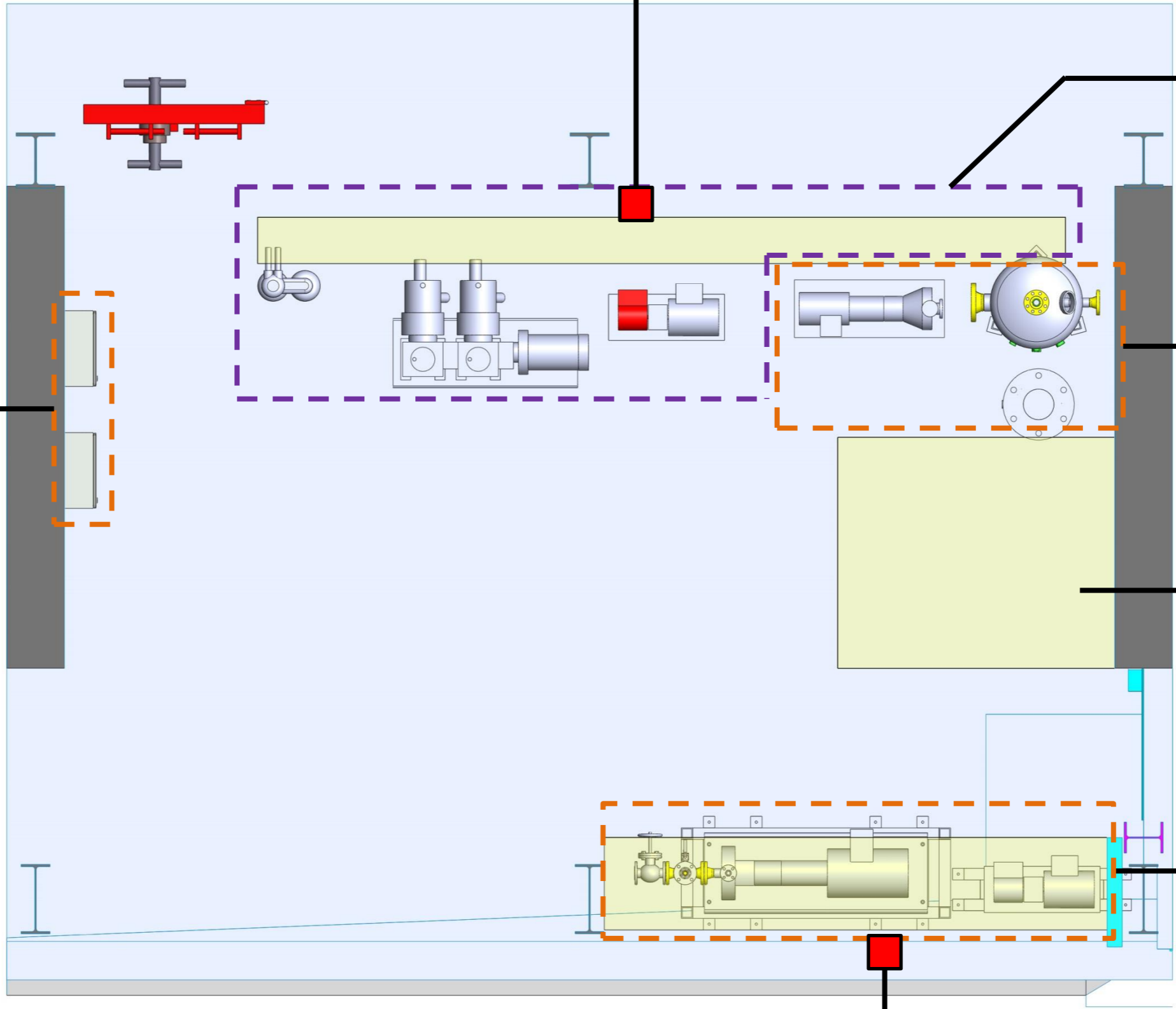

South-West

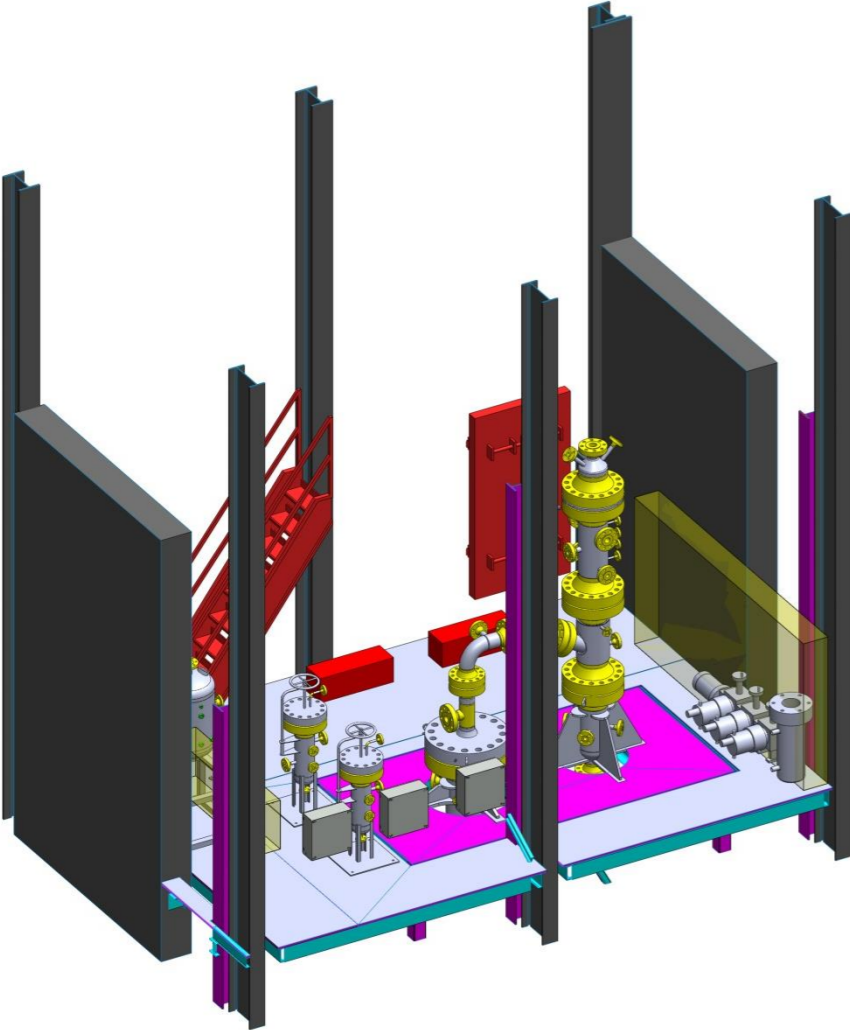

South

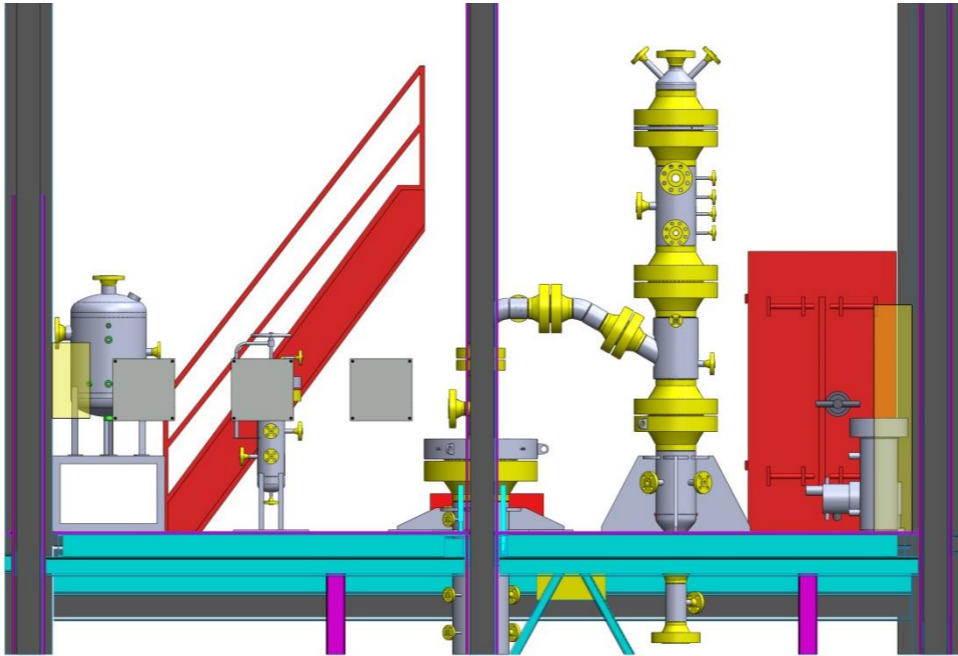

South-East

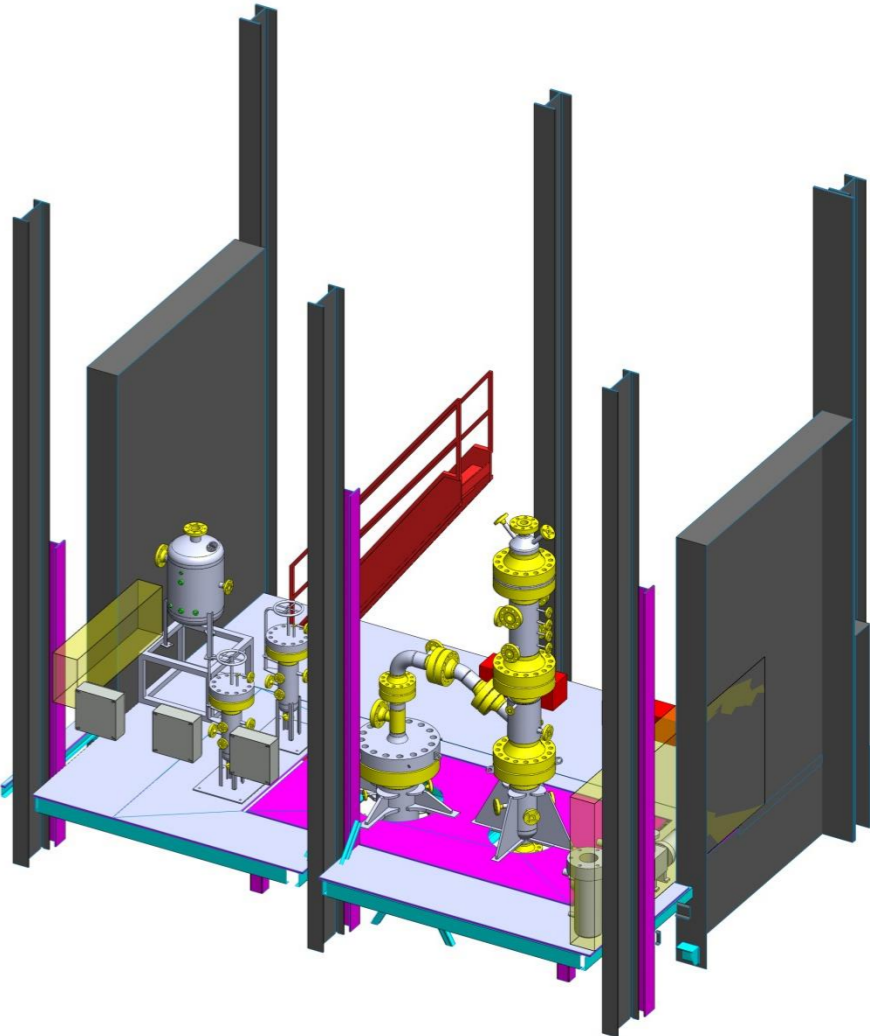

**Room M8
(multiple views)**



Quench and Scrubber
Injection Heaters
(H-2602, H-2603)

TC Junction
M8-4 (16 pt)

TC Junction
M8-3 (16 pt)

Quench-Scrubber (QS)
Line

TC Junction
M8-1 (8 pt)

Blowdown Tank
(V-3401)

TC Junction
M8-5 (8 pt)

Gas Bag Filters
(F-3201, F-3202)

Reactor Cooling
System;
excluding H-4301
(P&ID Sheet 4-03)

PCV Pressure Letdown
Flow Train
(P&ID Sheet 3-02)

TC Junction
M8-2 (16 pt)

Solenoid Cabinets x3
(SC-M8-1, SC-M8-2, SC-M8-3)

Scrubber Vessel
Top Head
(V-3201)

Quench Vessel (QV-3101),
Ash Handling Unit 1 (AH-3101)

**Room M8
(Top View)**

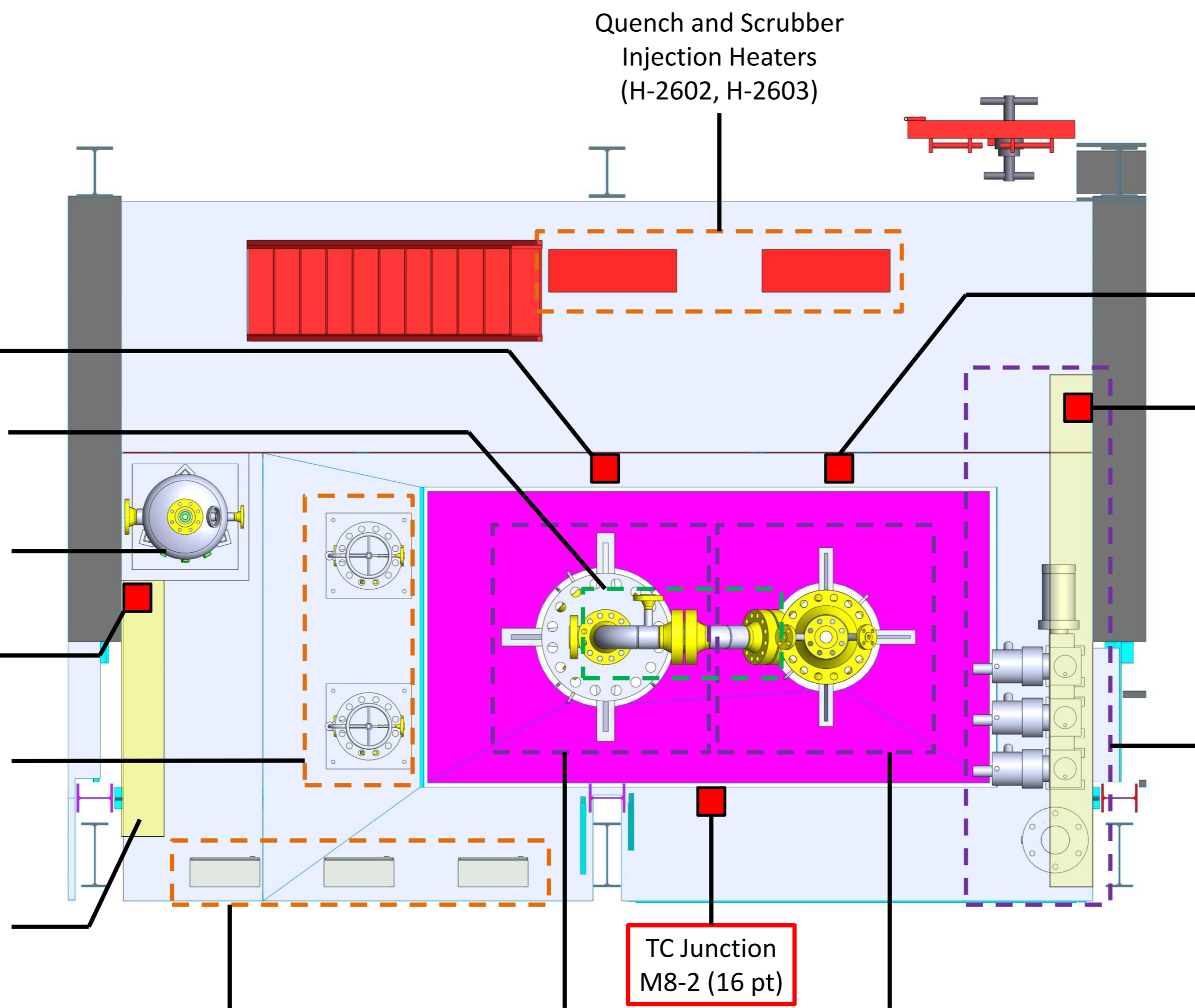

South-West

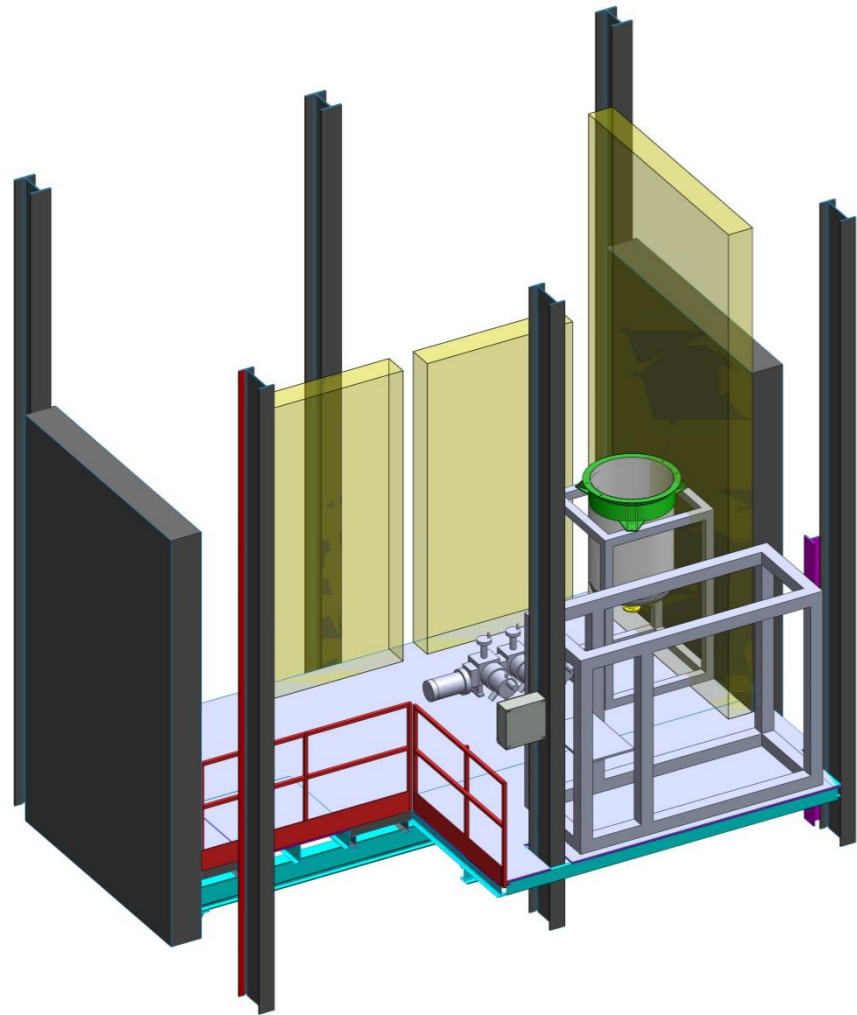

South

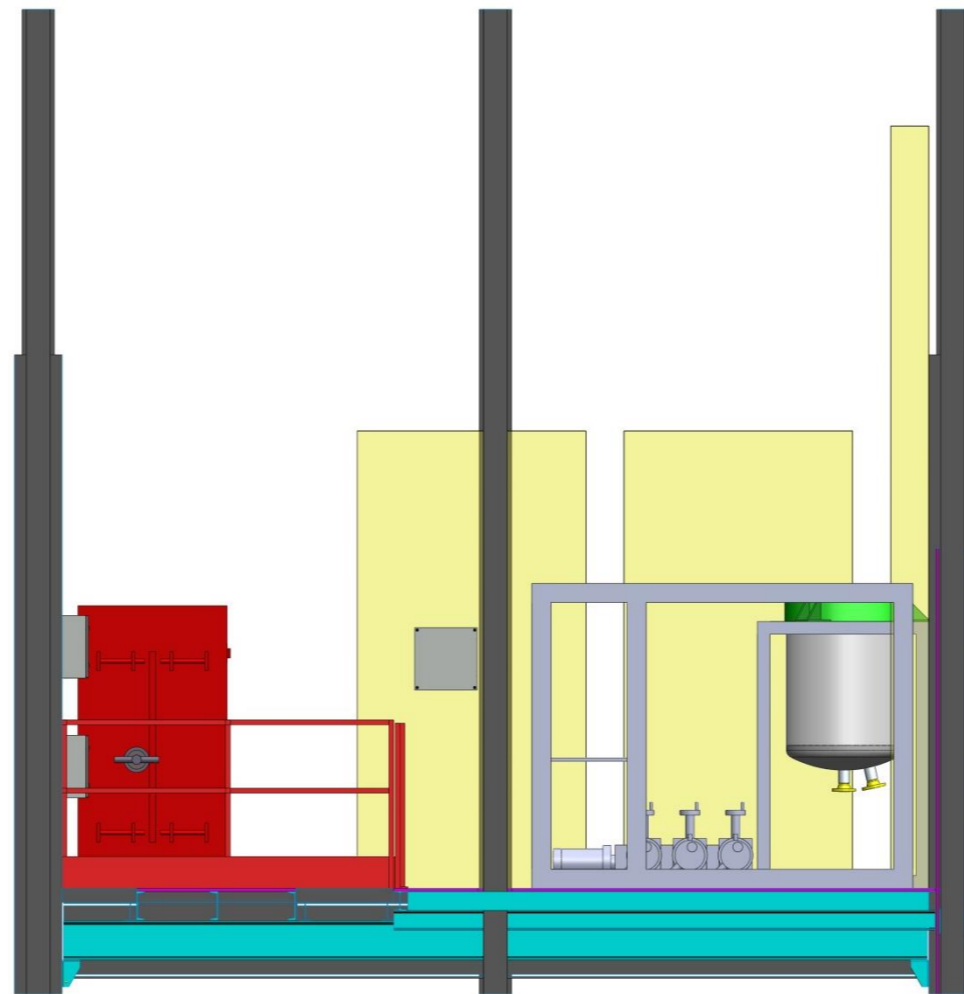

South-East

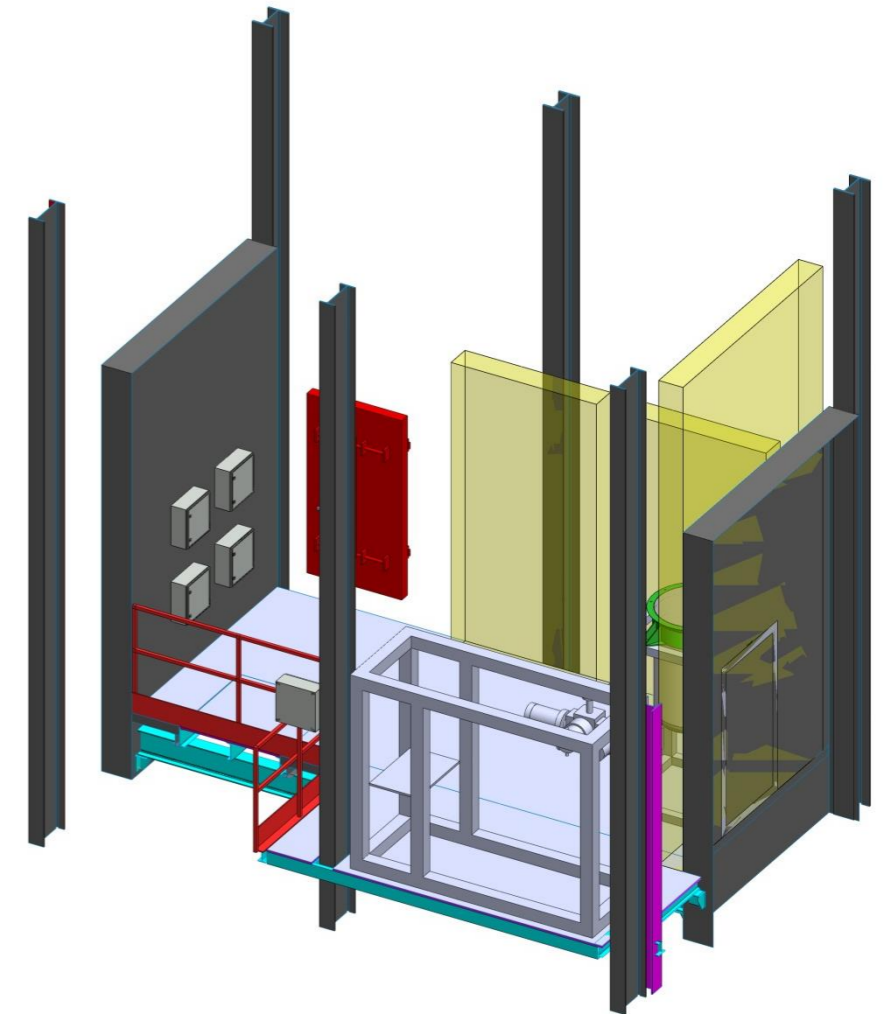

**Room M9
(multiple views)**

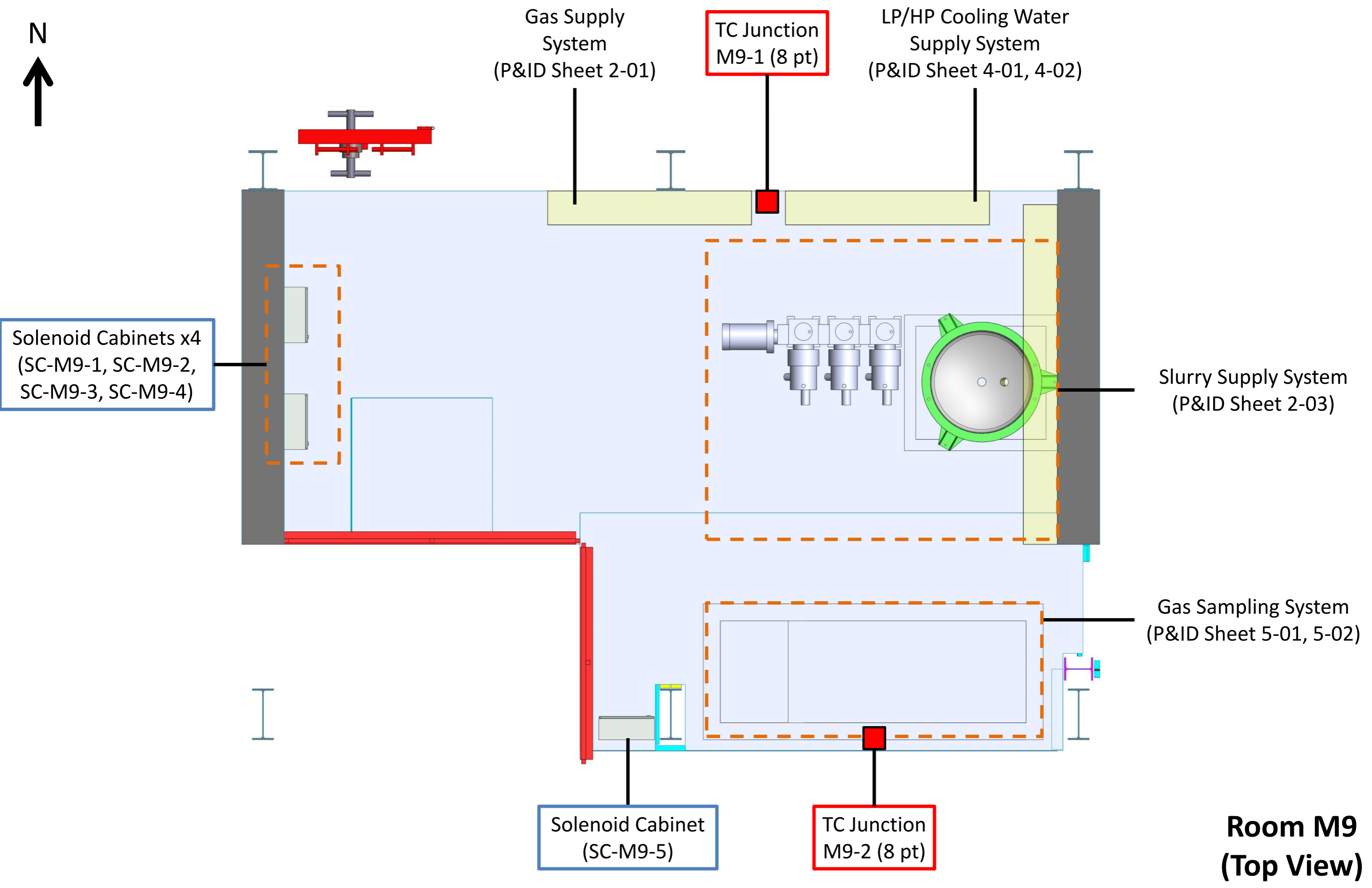

**Room M9
(Top View)**

South-West

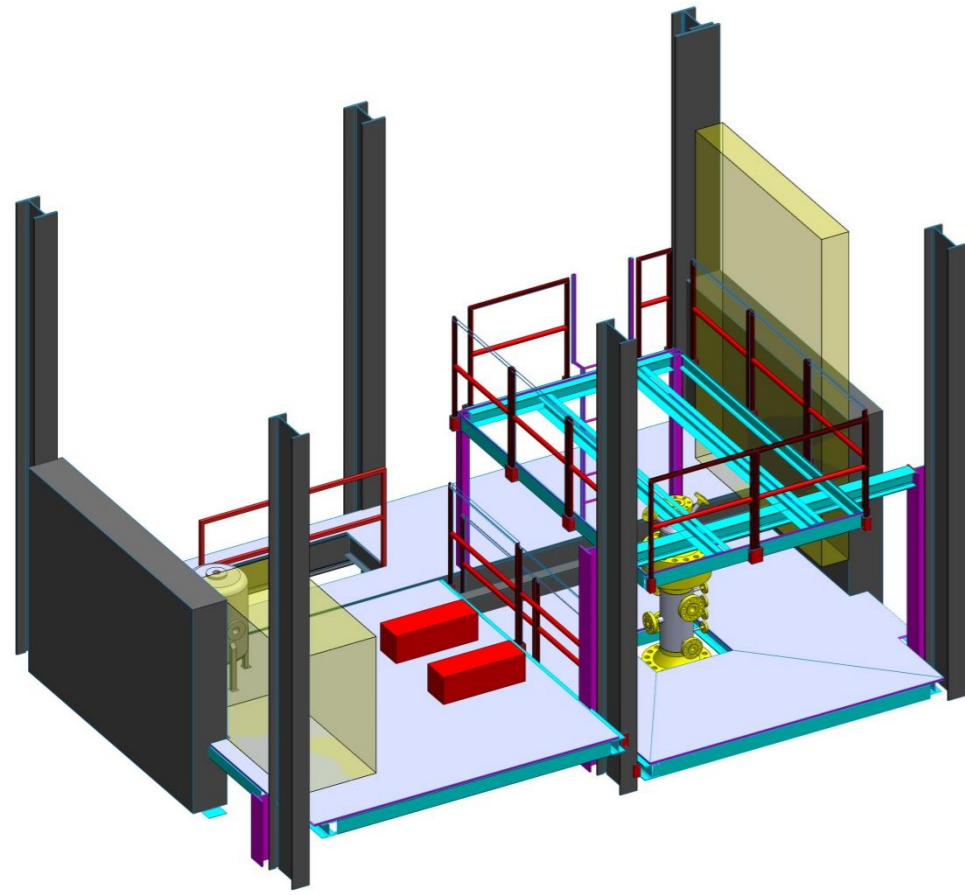

South

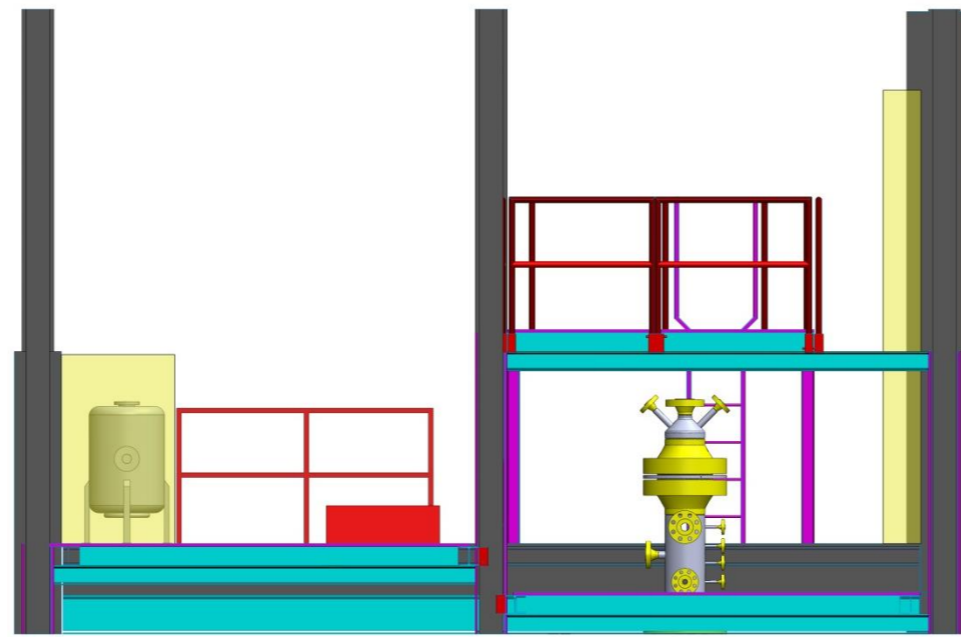

South-East

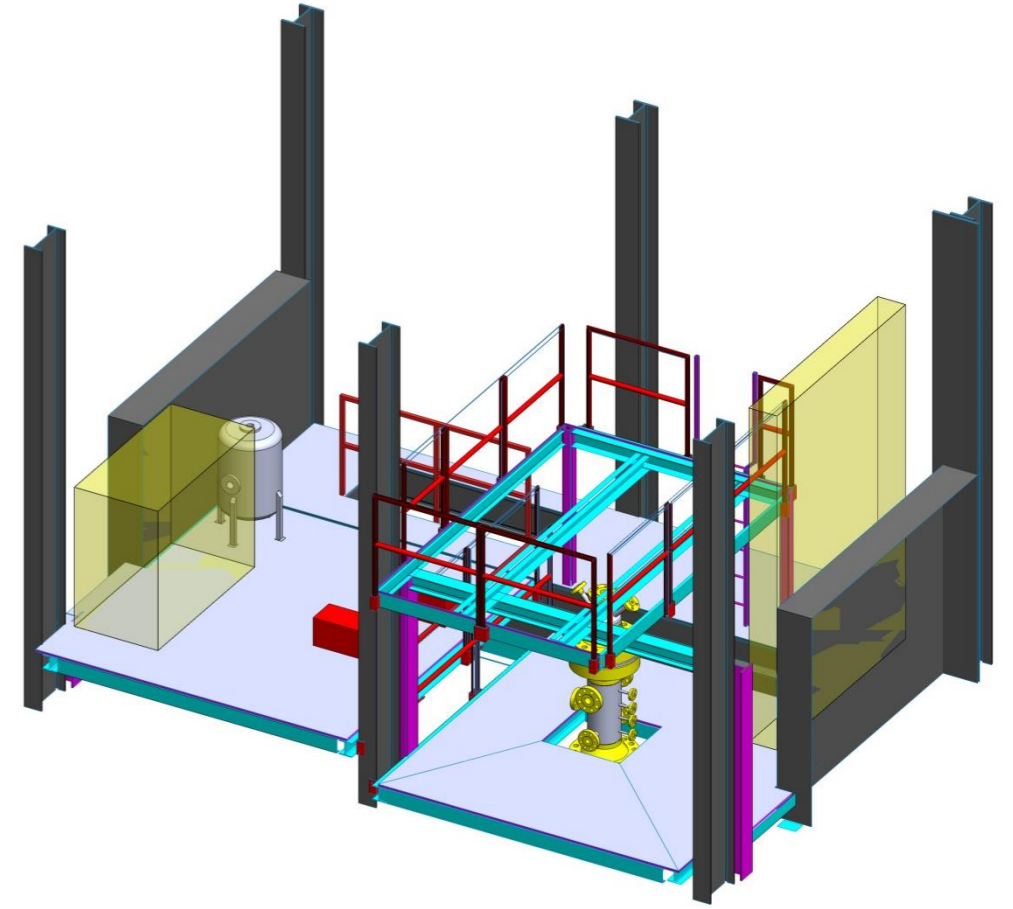

**M8 Mezzanine
(multiple views)**



TC Junction
Mezz-2 (8 pt)

TC Junction
Mezz-1 (8 pt)

Natural Gas
Supply System,
Ignition System
(P&ID Sheet 2-02)

Flare Knockout Drum
(V-3403)

Reactor Injection
Heater (H-2601),
Reactor Water Wall
Heater (H-4301)

TC Junction
Mezz-3 (24 pt)

TC Junction
Mezz-4 (24 pt)

Reactor Body (RX-3101),
Reactor Sandwich Flange (RF-3101),
Reactor Top Head (RH-3101),
Burner (BR-3101)

**M8 Mezzanine
(Top View)**

