

ANISHINAABE

LEBRETON FLATS PARK: EAST SIDE

INTERPRETIVE PANELS

Presented to
Canadian Heritage
July 21 2016, revision



L'idée projetée
dans la **forme**

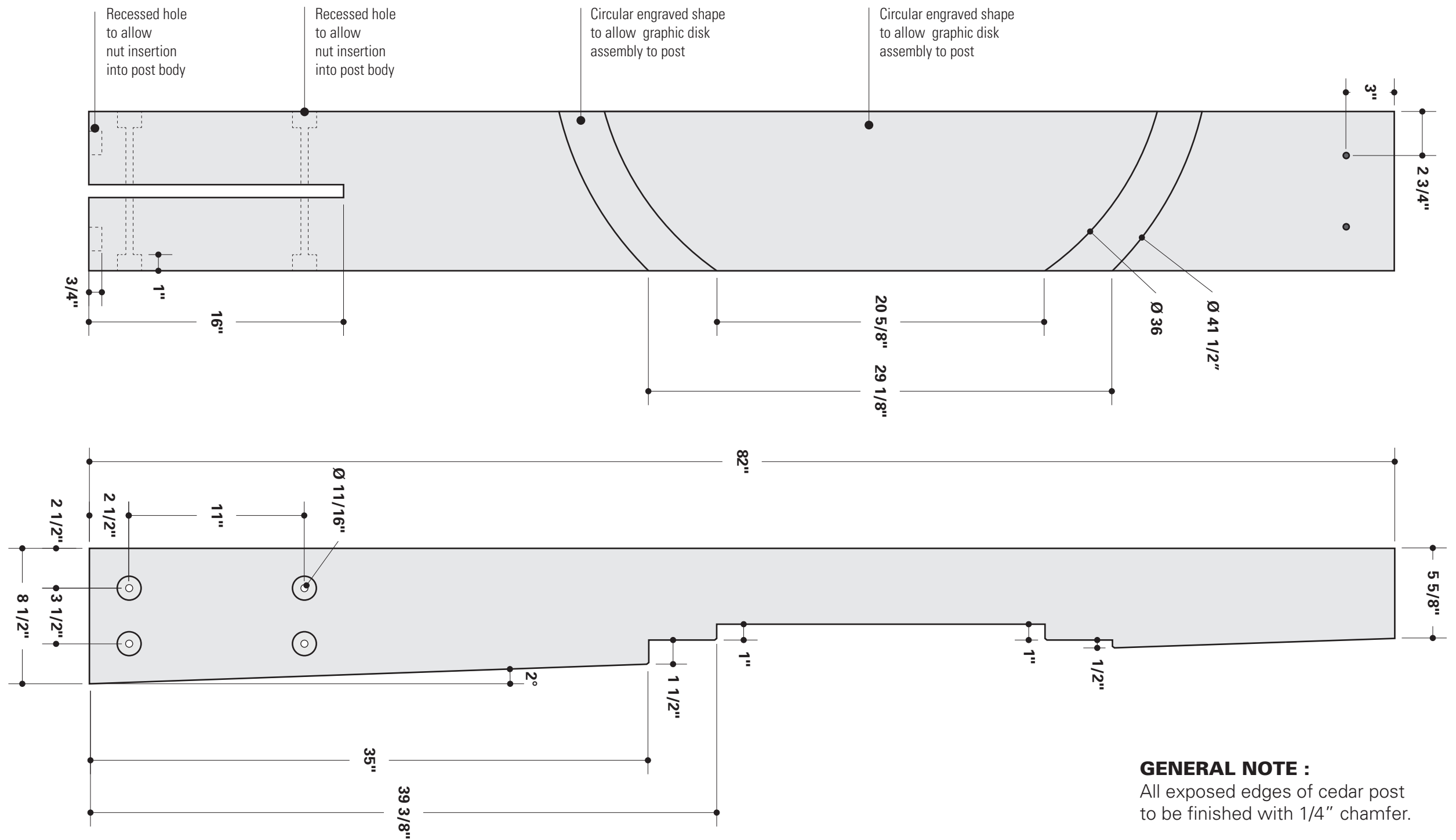
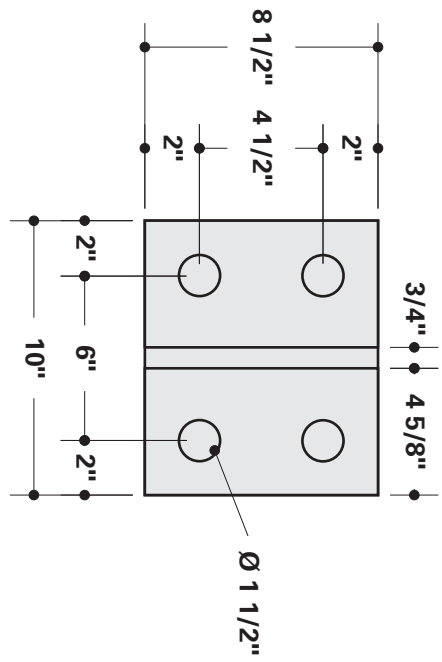

GENERAL NOTE :
All exposed edges of cedar post to be finished with 1/4" chamfer.

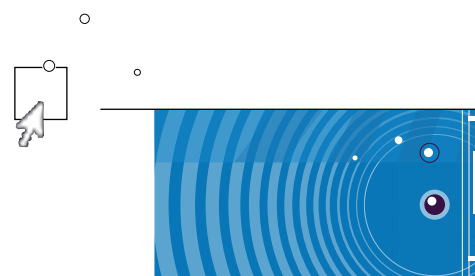

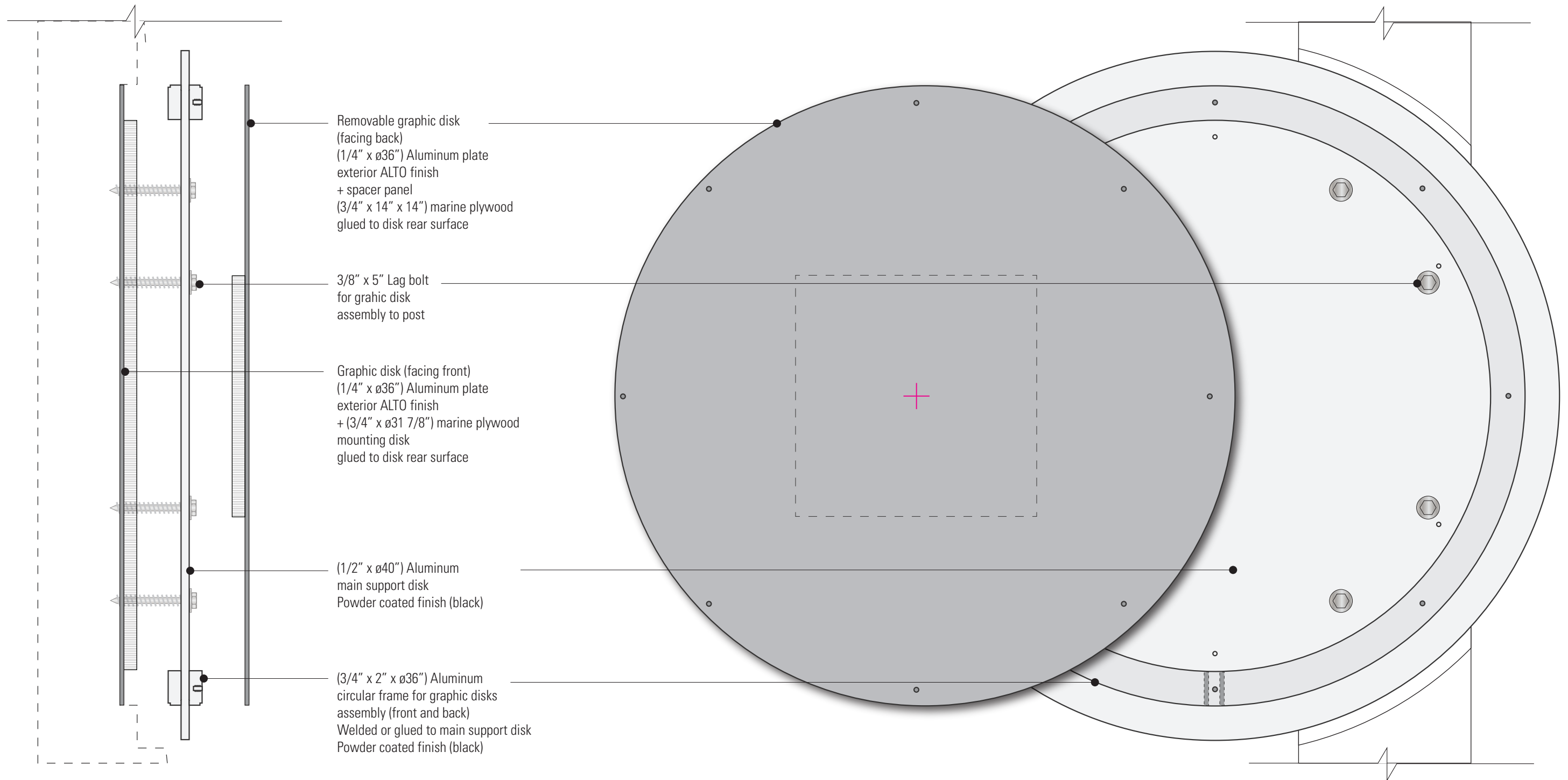

GENERAL NOTE:

All exposed edges of aluminum panels to be finished with 1/8" chamfer.

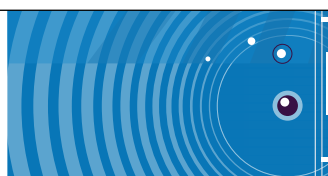
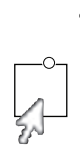

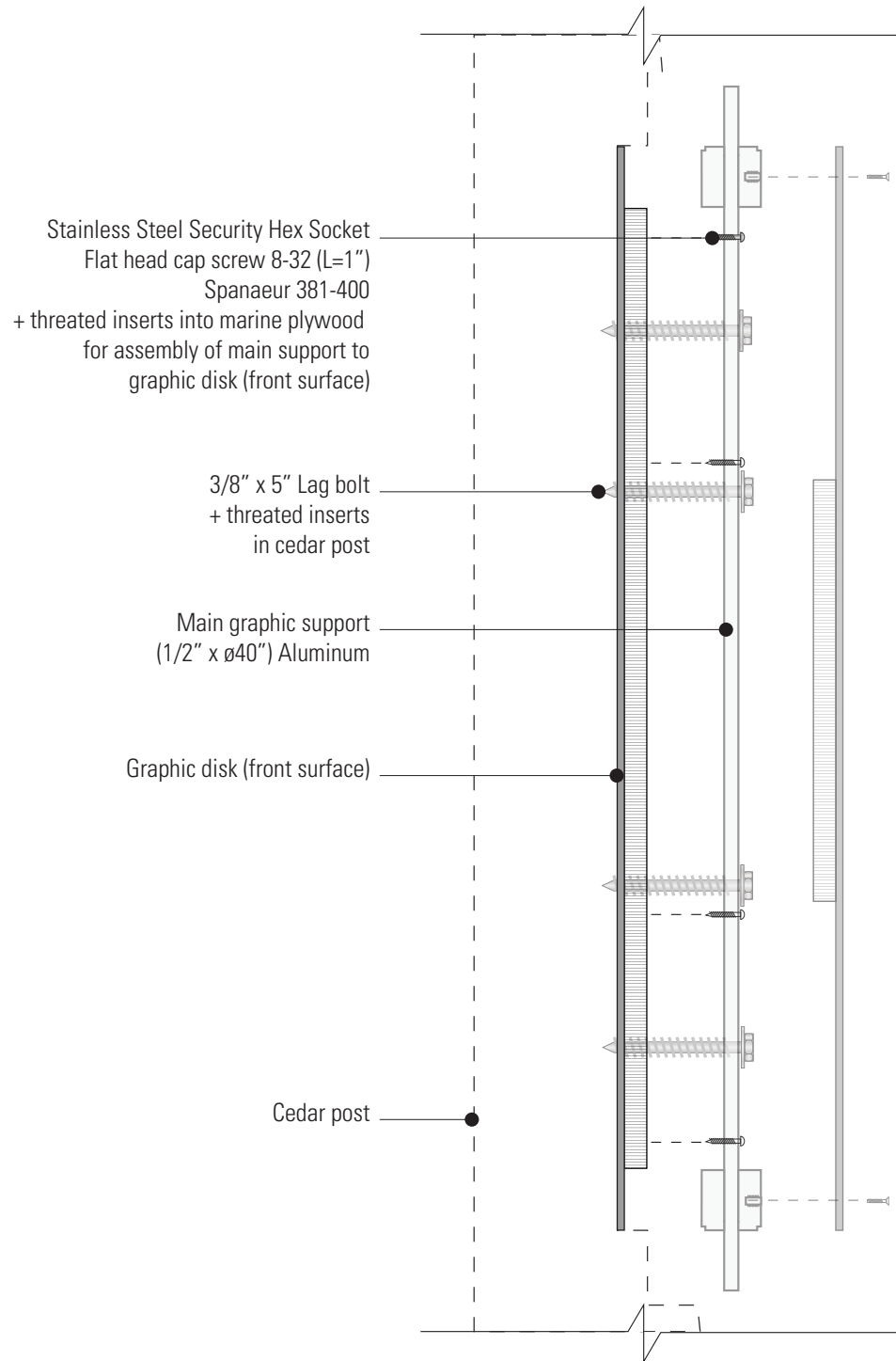

EXPLODED CROSS SECTION

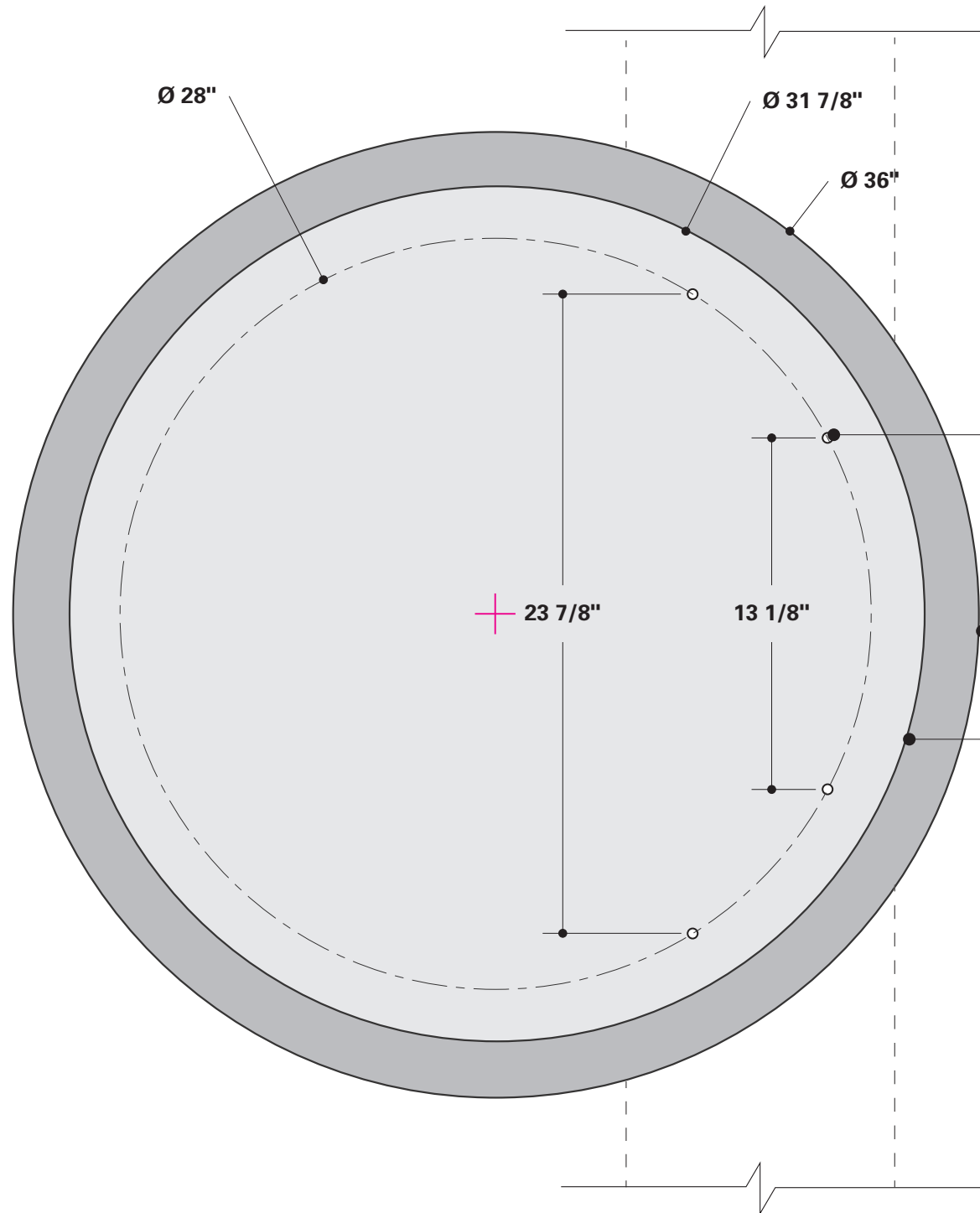

FRONT VIEW

GENERAL NOTE:
All exposed edges of aluminum panels to be finished with 1/8\"/>

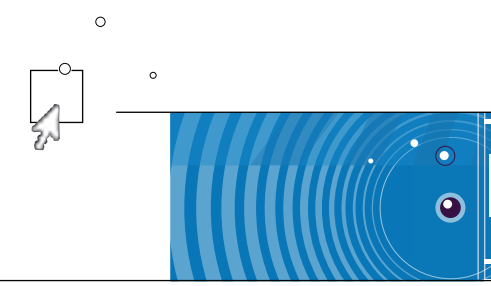

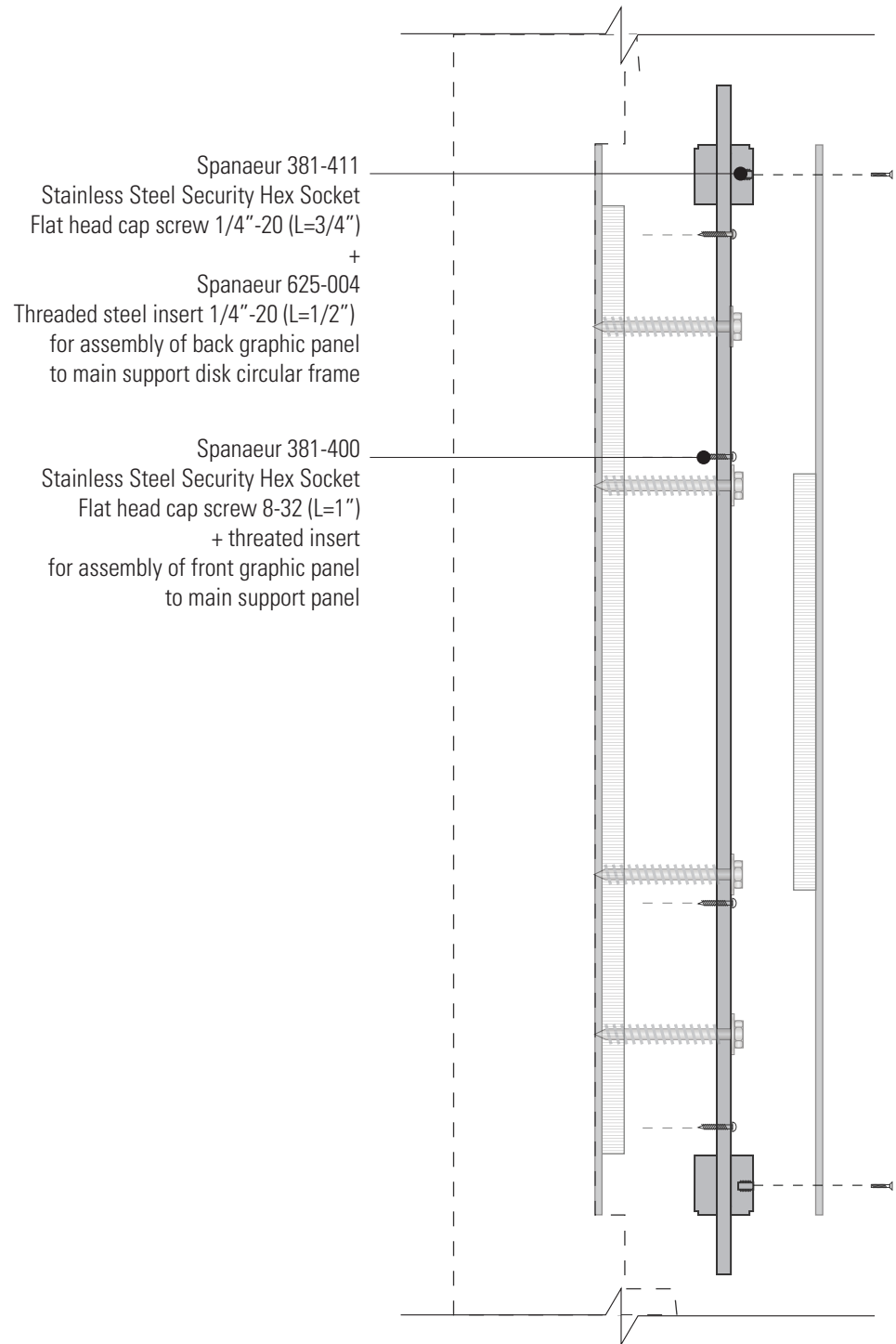

EXPLODED CROSS SECTION

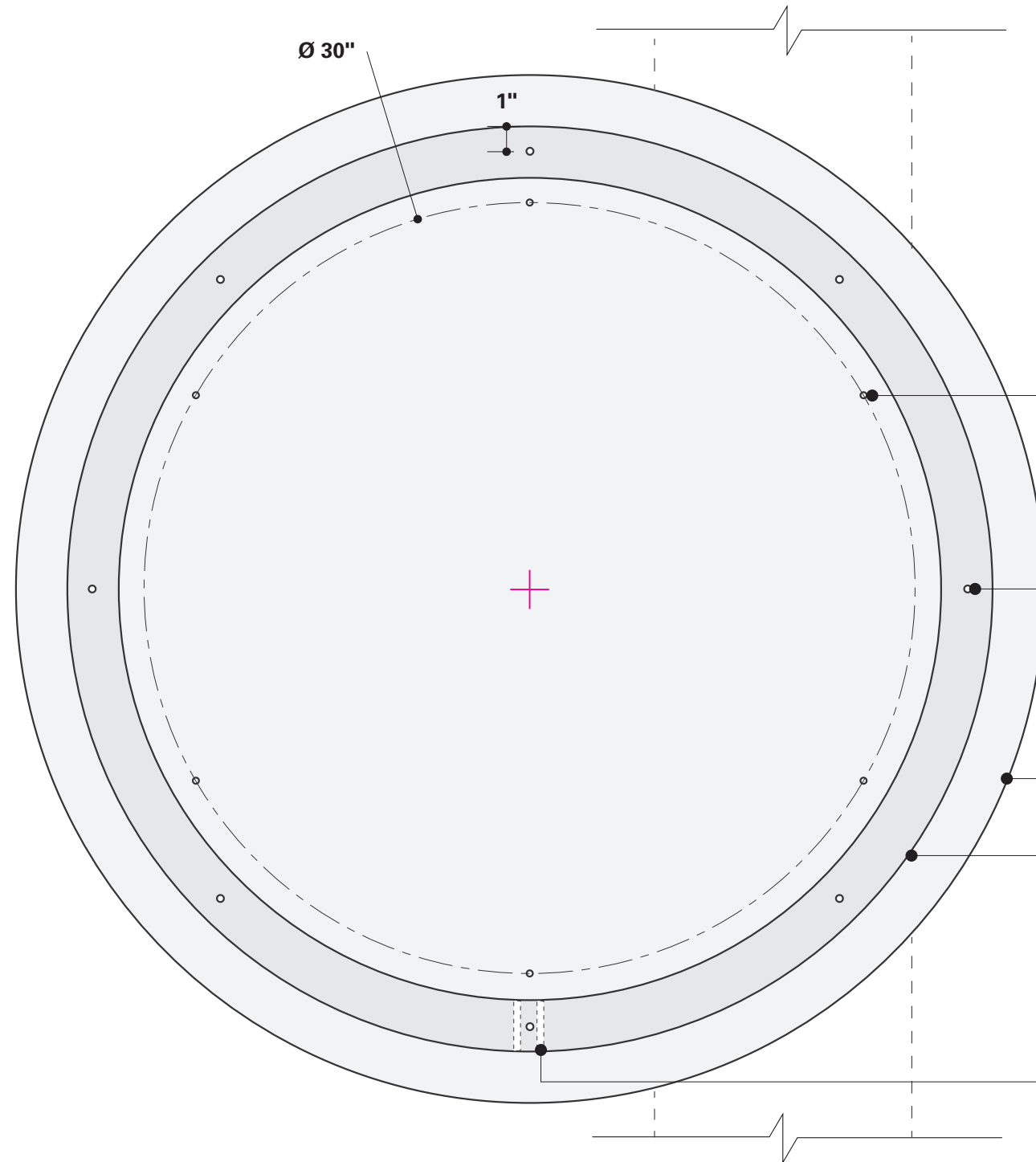

REAR VIEW

GENERAL NOTE:
All exposed edges of aluminum panels
to be finished with 1/8" chamfer.

8-32 Insert perforation
for assembly of front graphic disk

1/4"-20 Insert perforation
for assembly of back graphic disk

(1/2" x Ø40") Aluminum plate
main support disk

(3/4" x 2" x Ø36") Aluminum circular frame
1/8" reveal on exterior edge
Powder coated finish (black)

Aluminum circular frame perforations
for water drainage

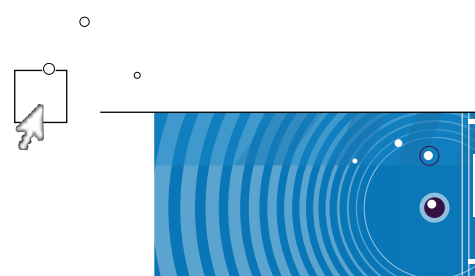

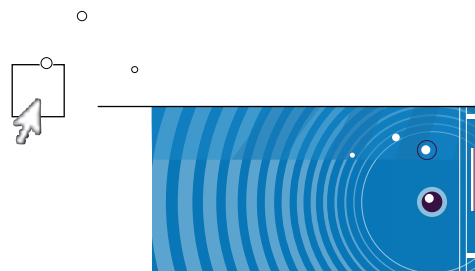
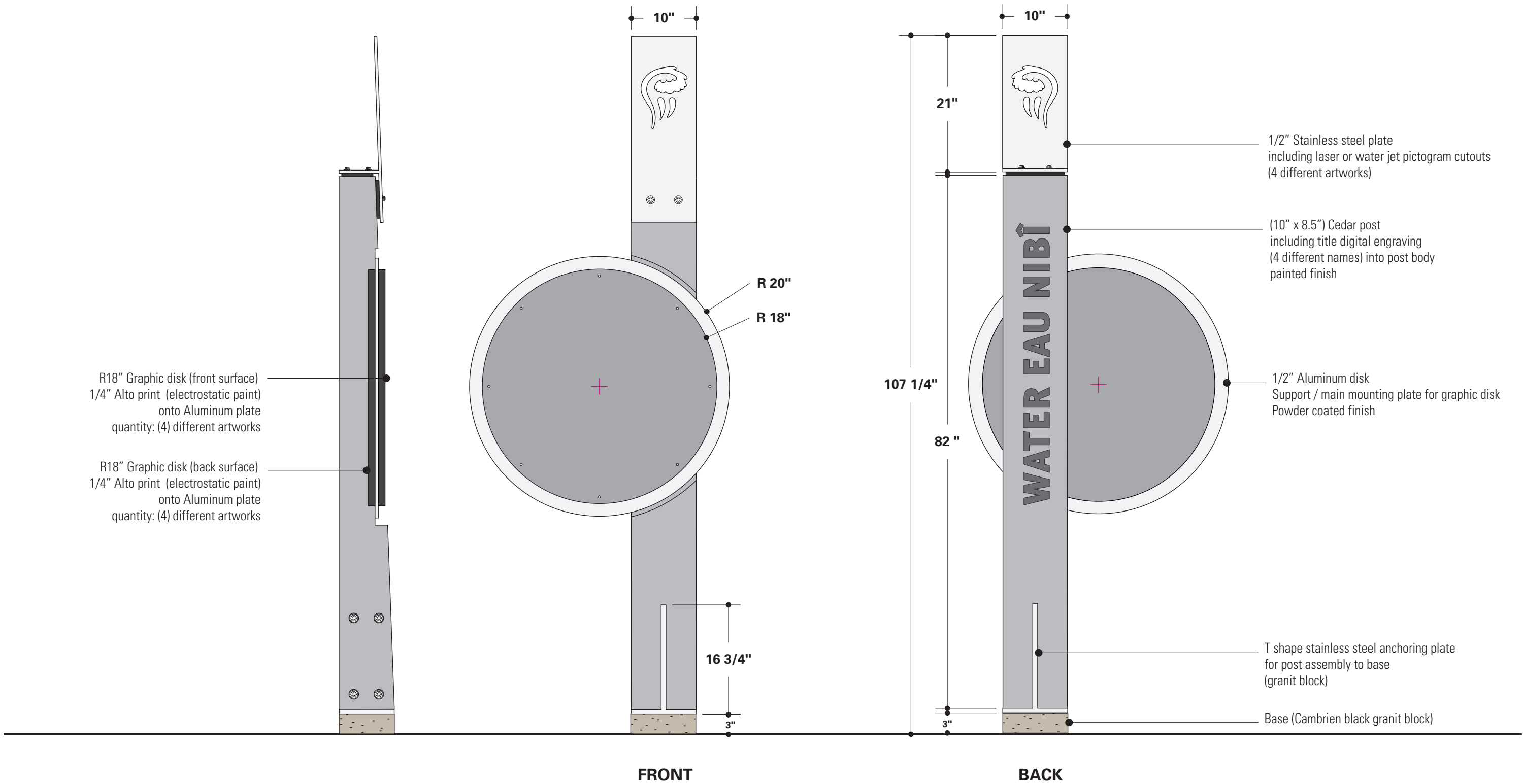

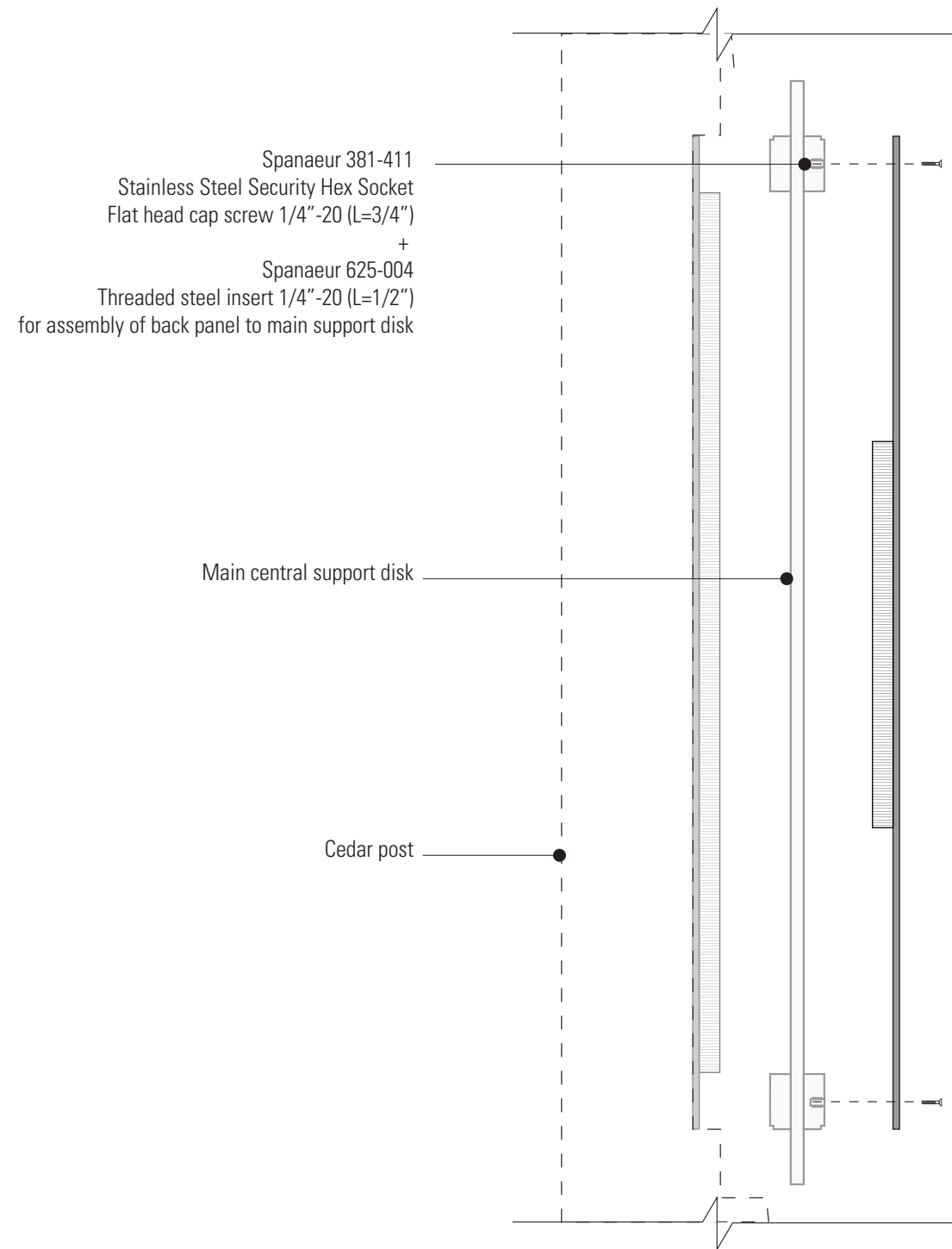

EXPLODED CROSS SECTION

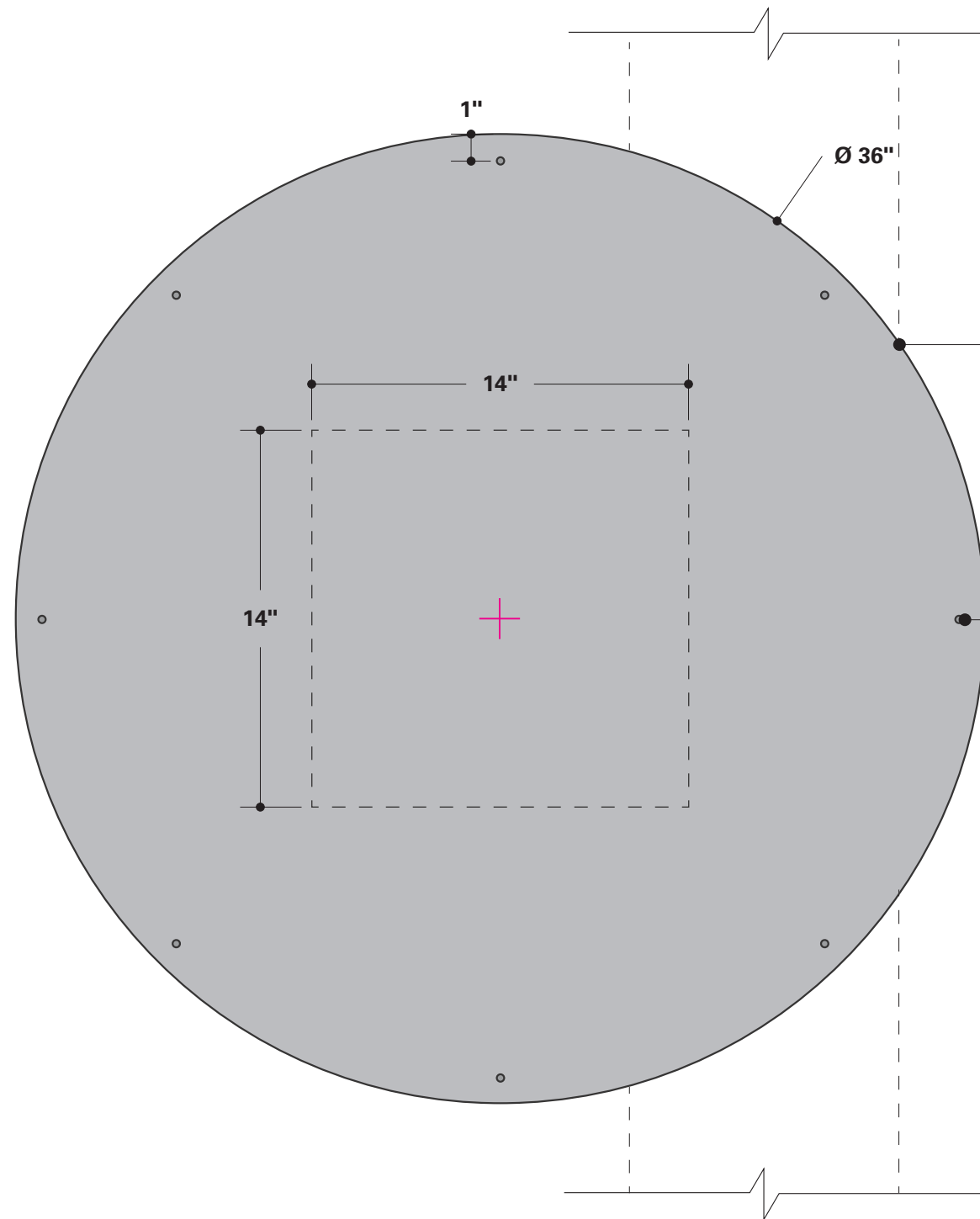

ELEVATION

GENERAL NOTE:
All exposed edges of aluminum panels to be finished with 1/8" chamfer.

(1/4" x Ø36") Aluminum plate
ALTO graphic finish
+ (3/4" x 14" x 14") Marine plywood
spacer panel glued to back panel

Perforation for 1/4"-20 screw
for assembly of back panel
to circular frame

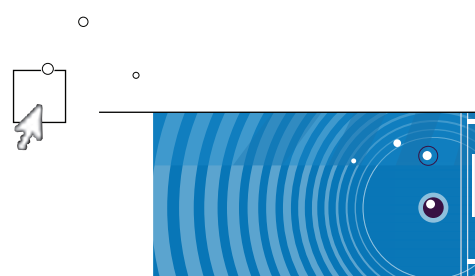

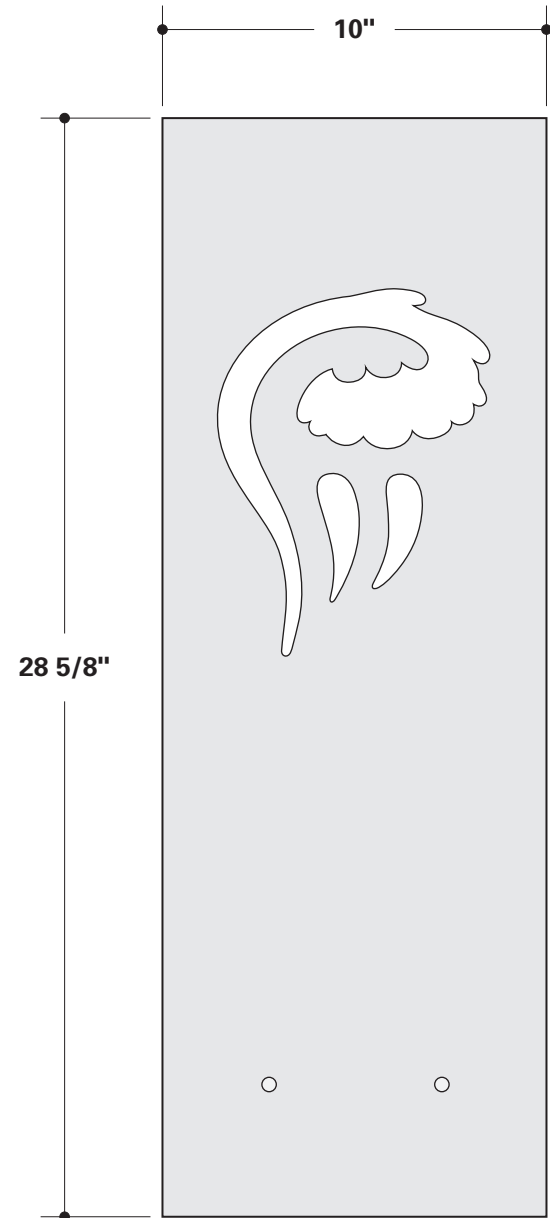

WATER

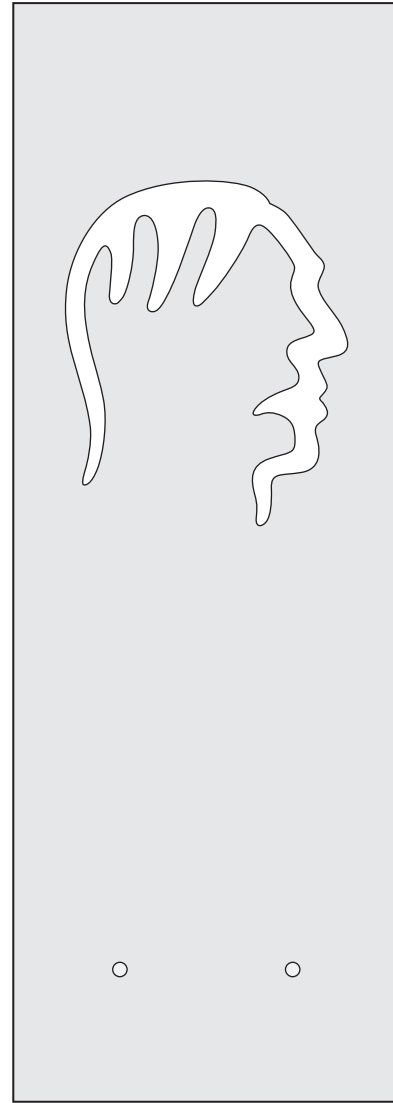

PEOPLE

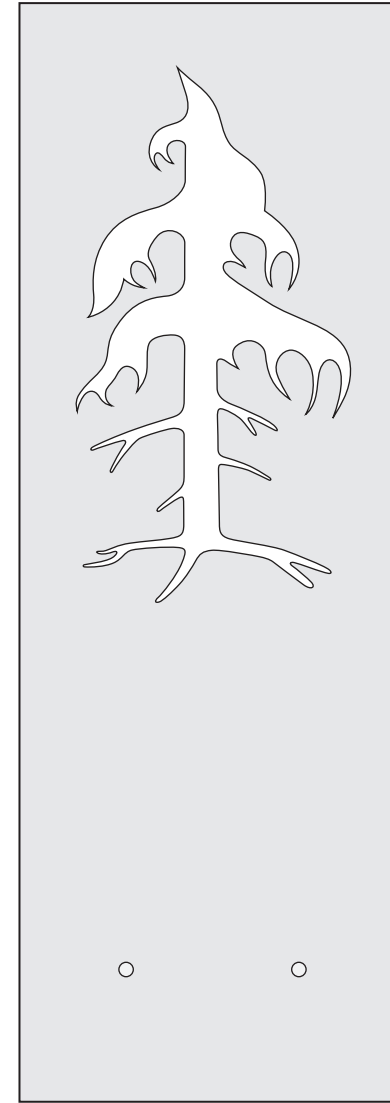

EARTH

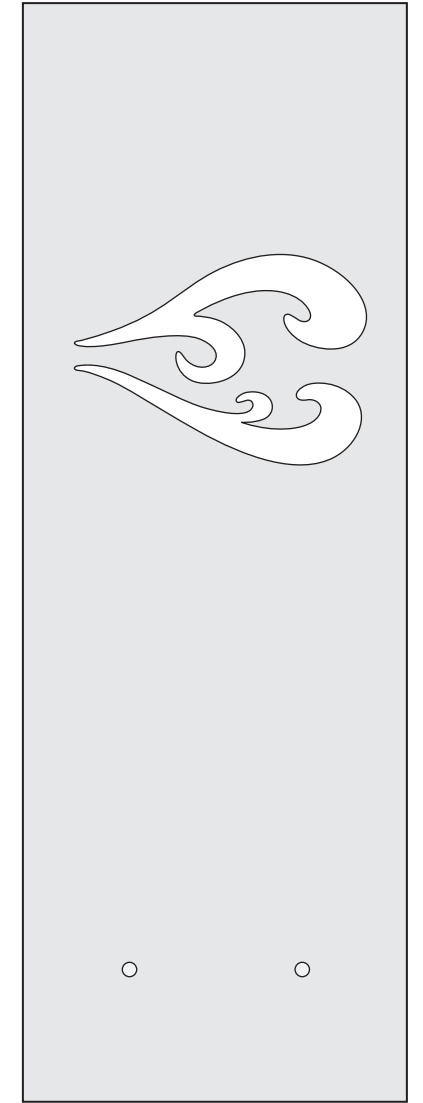

AIR

GENERAL NOTE:

Icon drawing to be provided in Illustrator CS6 vector format.
Fabricator to be responsible of the final file preparation for water jet or laser cutout.

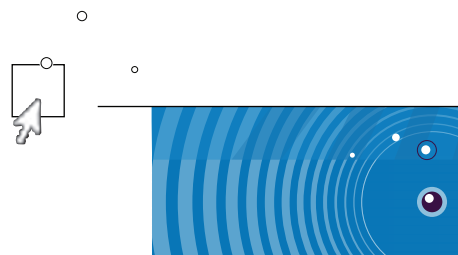
 	<p>NOTES</p> <p>Phase 3: PLANS AND SPECIFICATIONS</p>		<p>l'idée projetée dans la forme</p>	<p>NOM DU PROJET / PROJECT NAME</p> <p>Interpretive Panels Anishinabe Park East Side</p>	<p>TITRE DU DESSIN / DRAWING TITLE</p> <p>Thematic icon cutout details</p>	<p>INFORMATIONS</p> <p>DATE: 17/05/2016 DRAWN BY: Julien Le Hégarat VERIFIED BY: Frédéric St-Laurent SCALE: 1:5</p>	<p>FEUILLE #</p> <p>08</p>
--	---	---	--------------------------------------	---	---	--	-----------------------------------

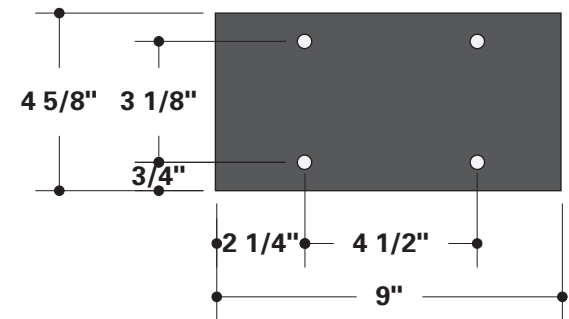

TOP SPACER BLOCK DETAIL

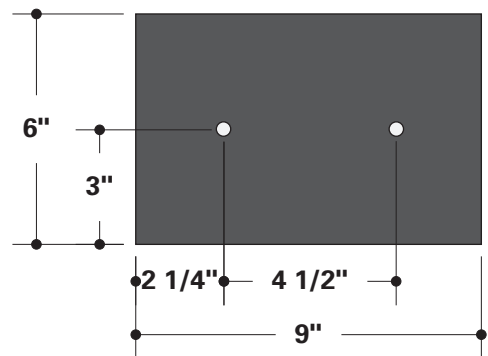

VERTICAL SPACER BLOCK DETAIL

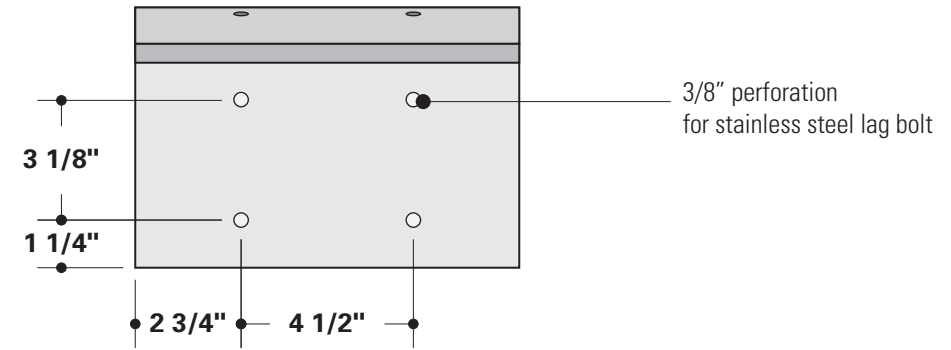
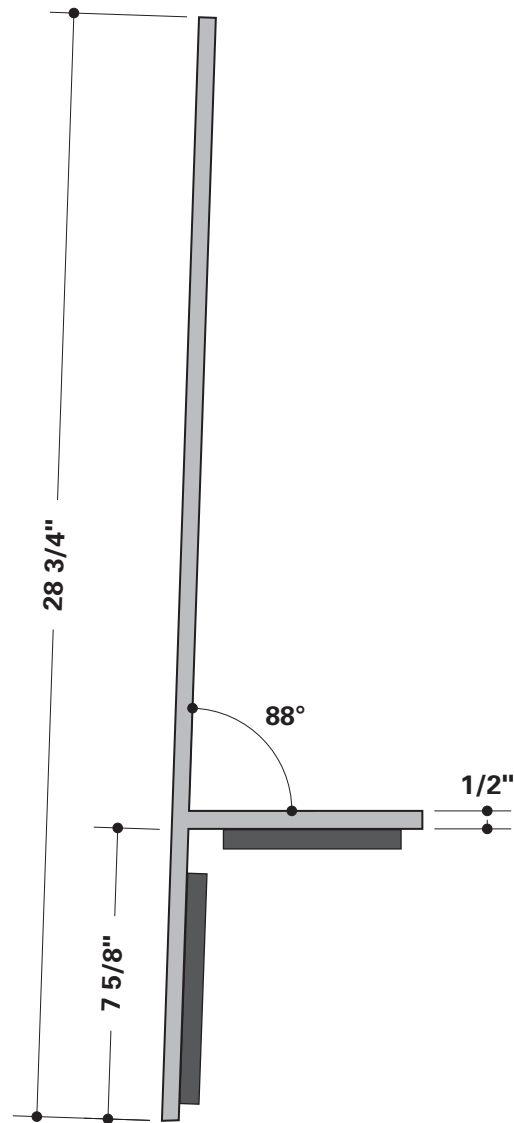

3/8" perforation for stainless steel lag bolt

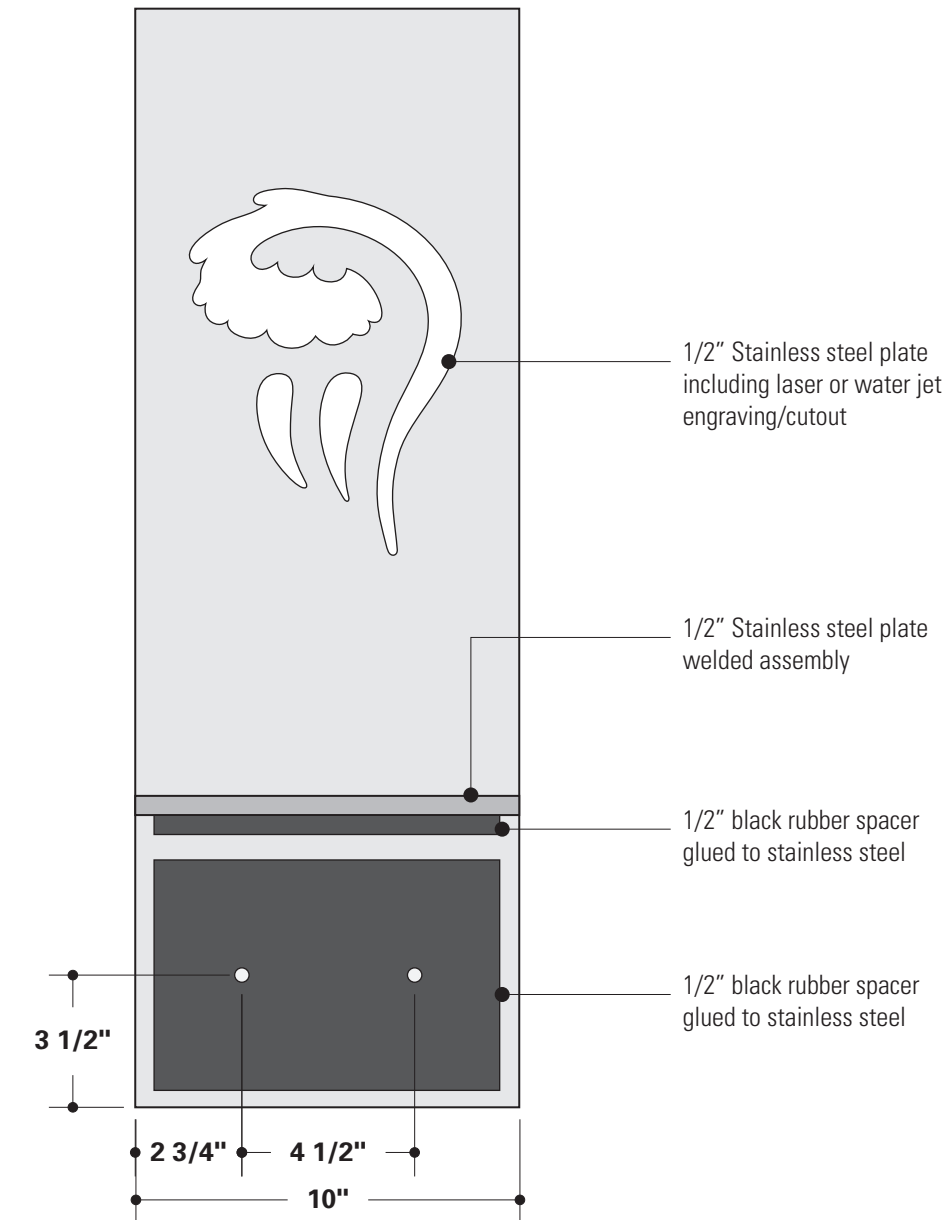

1/2" Stainless steel plate including laser or water jet engraving/cutout

1/2" Stainless steel plate welded assembly

1/2" black rubber spacer glued to stainless steel

1/2" black rubber spacer glued to stainless steel

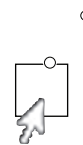

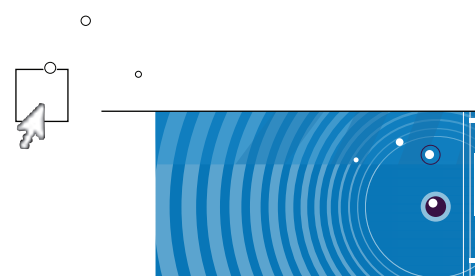
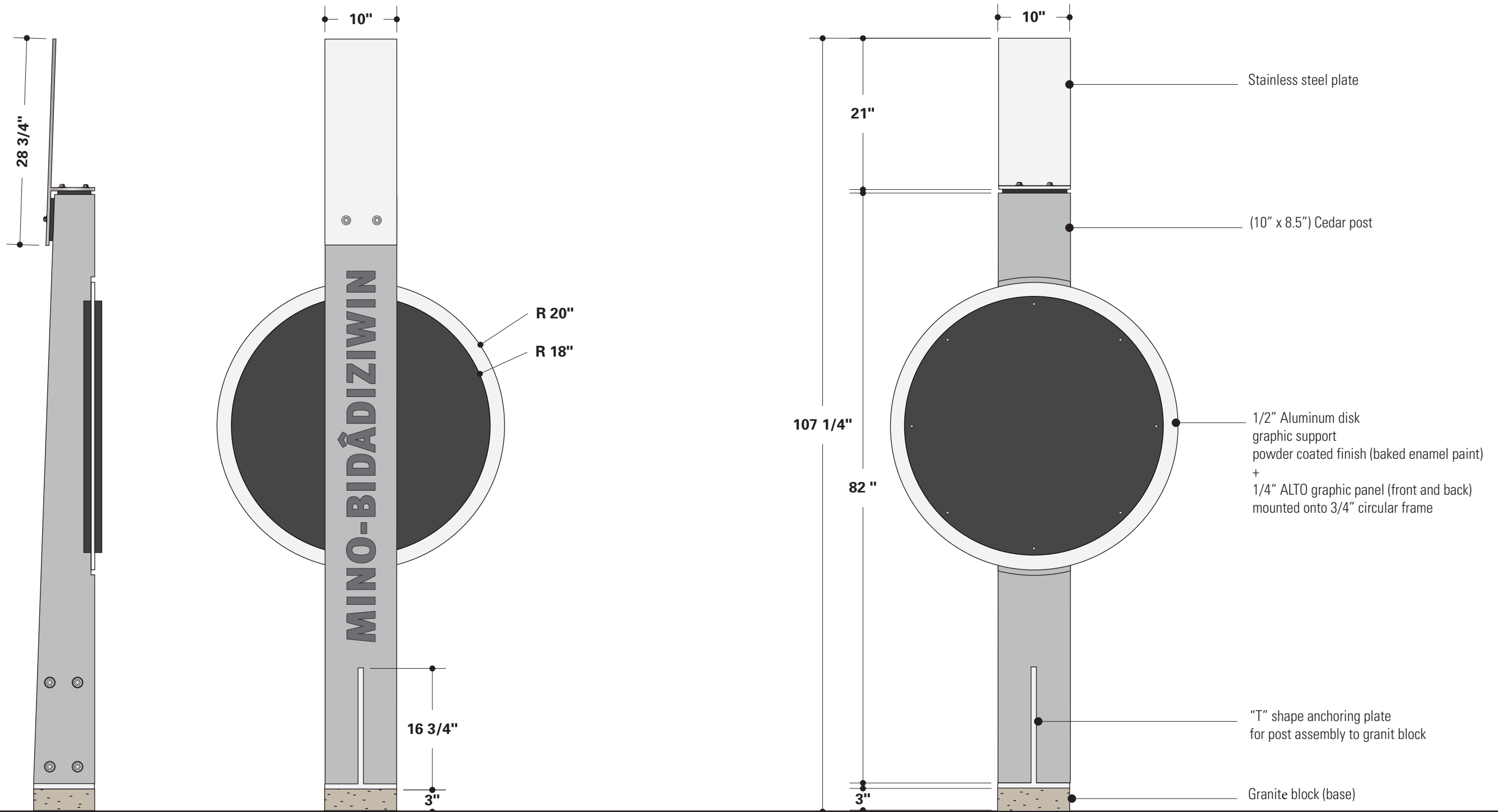

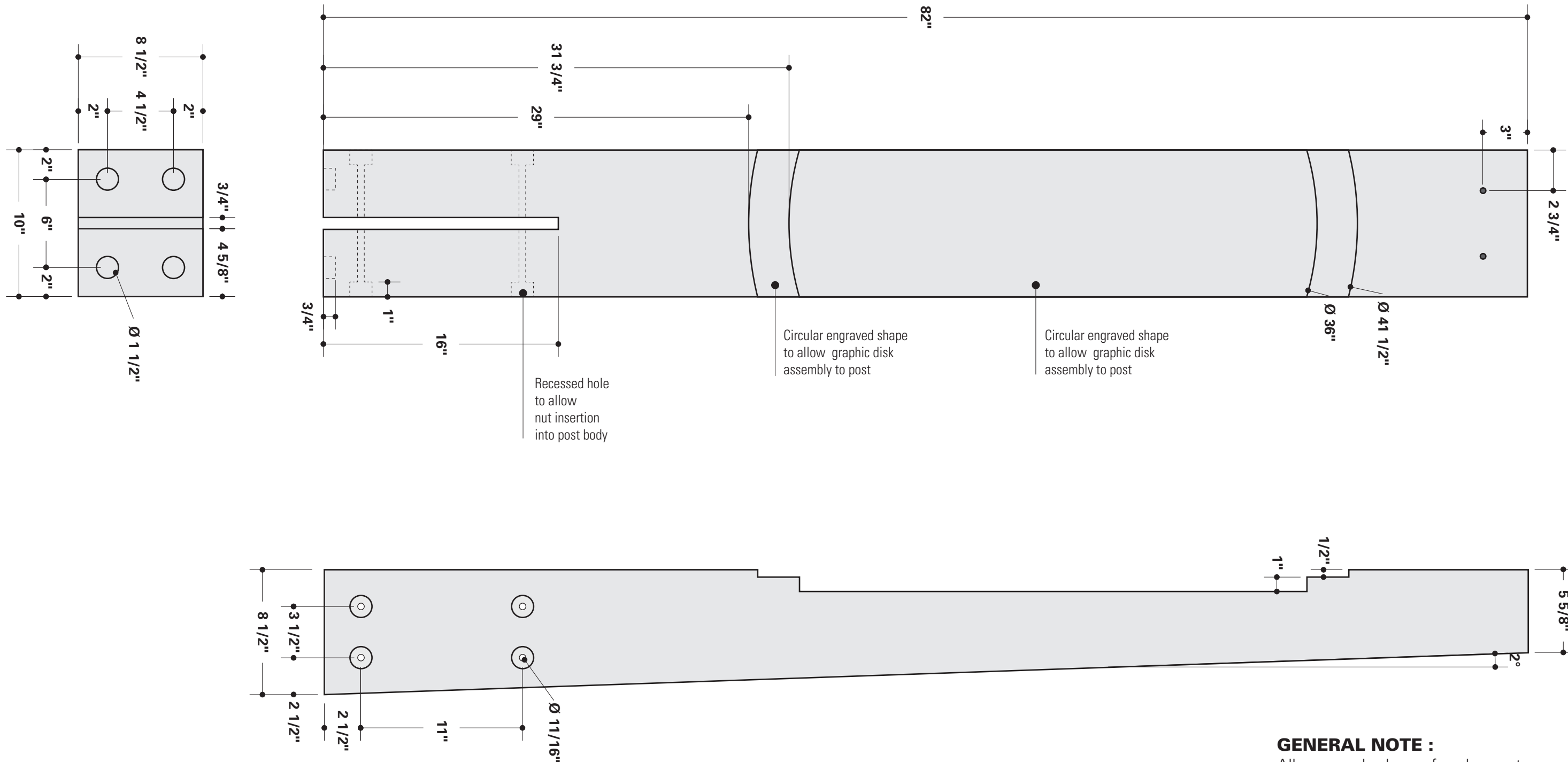

GENERAL NOTE :
 All exposed edges of cedar post to be finished with 1/4" chamfer.

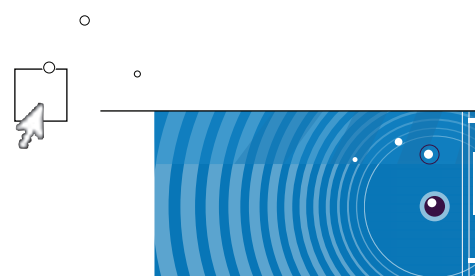

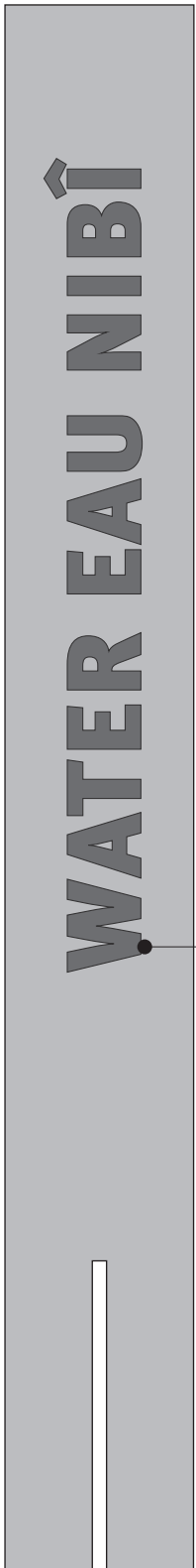

3/4" depth digital engraving
sandblasted or water jet
all edges to be sharp and clean
painted finish into post body

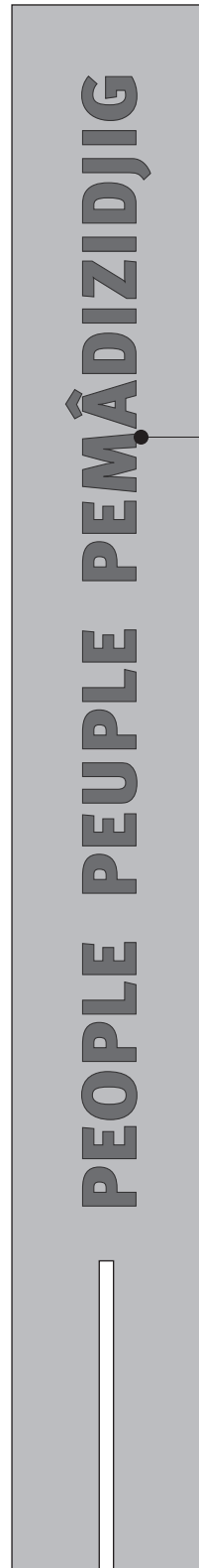

Colour reference
to be determined



Colour reference
to be determined

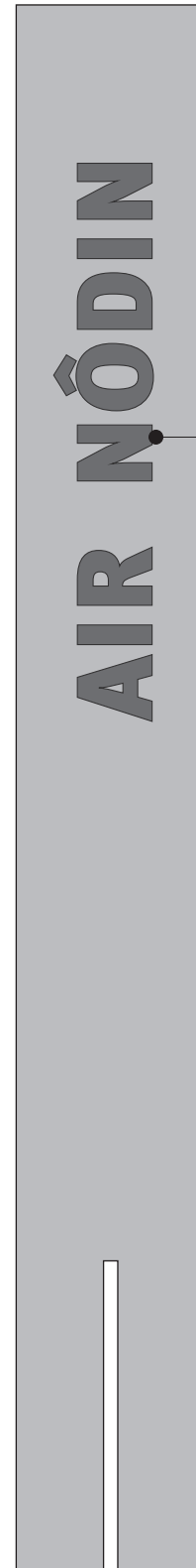

Colour reference
to be determined

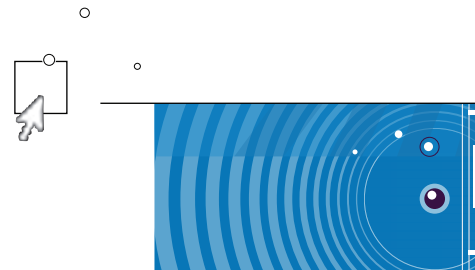

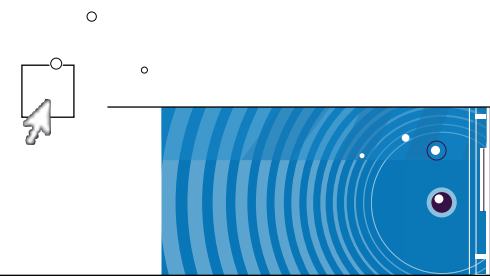
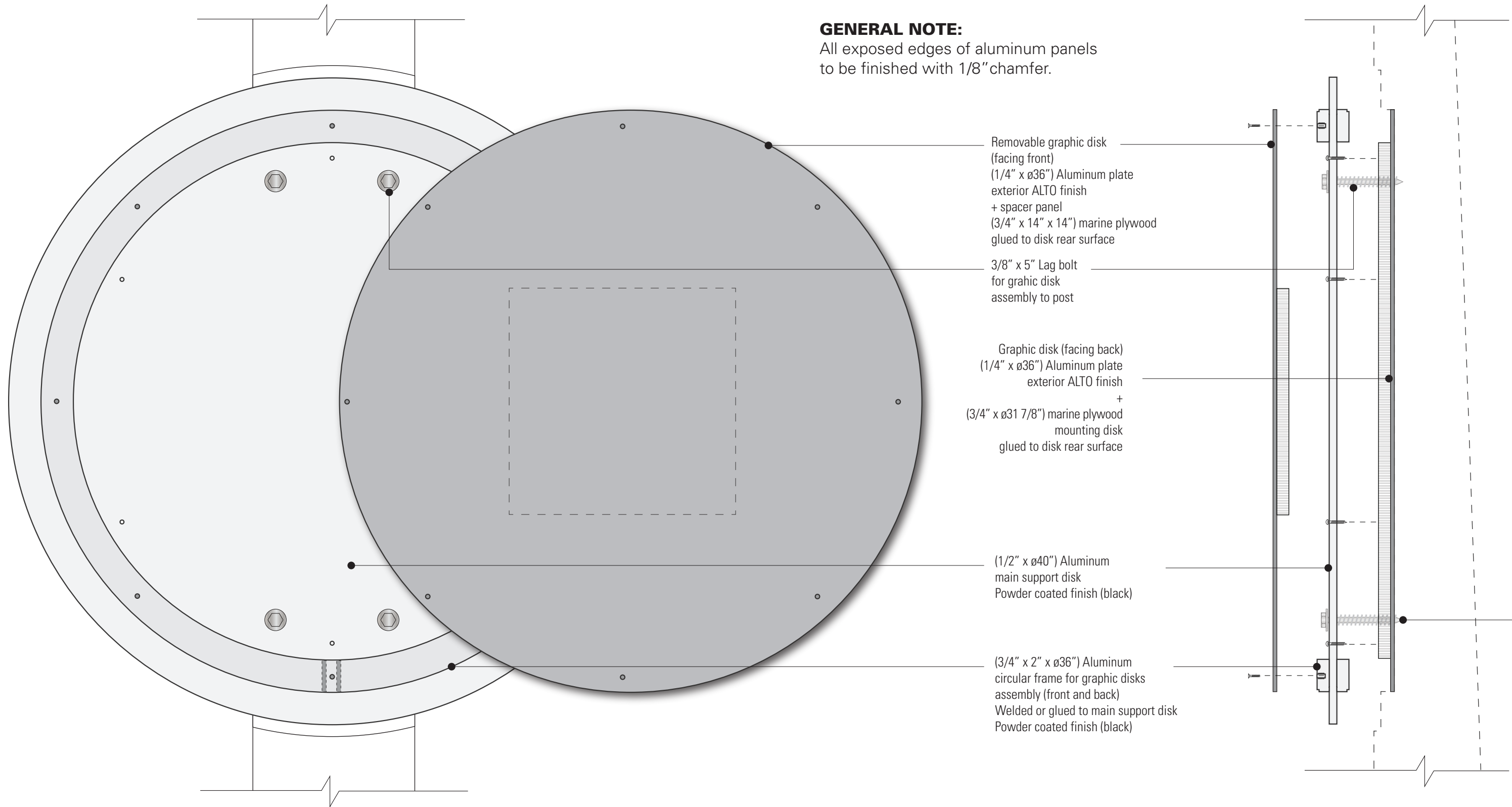

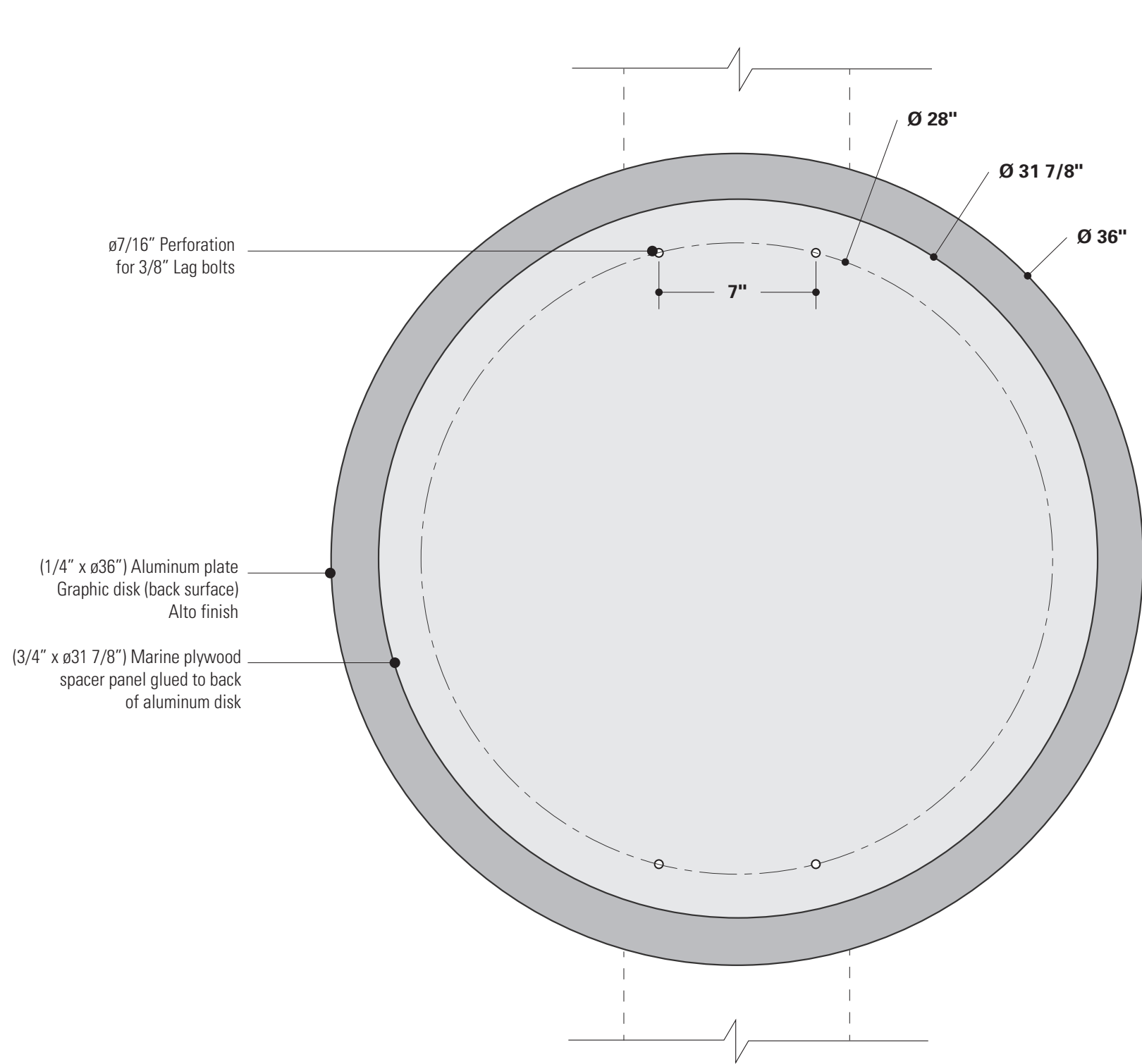

FRONT VIEW

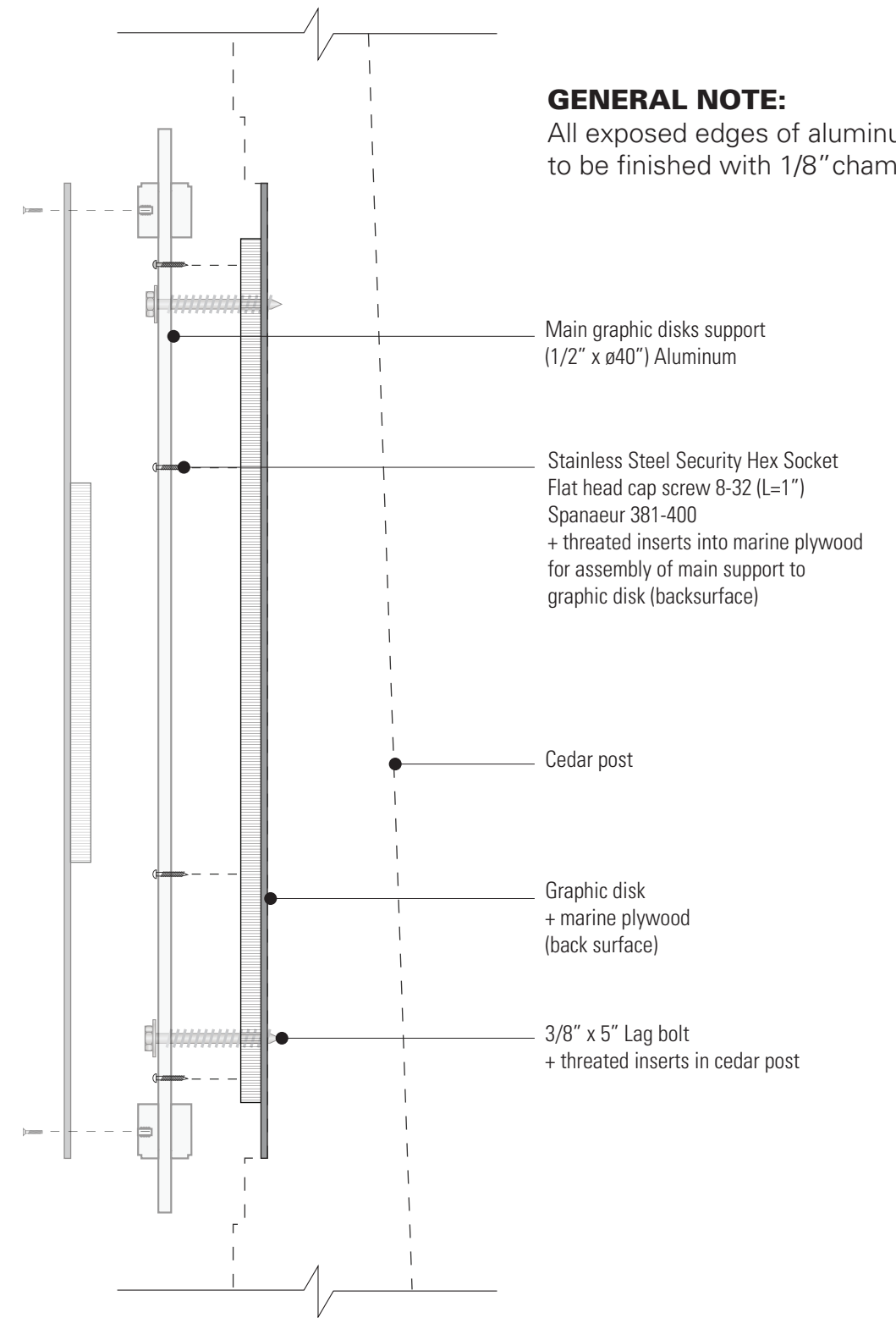

GENERAL NOTE:

All exposed edges of aluminum panels to be finished with 1/8" chamfer.

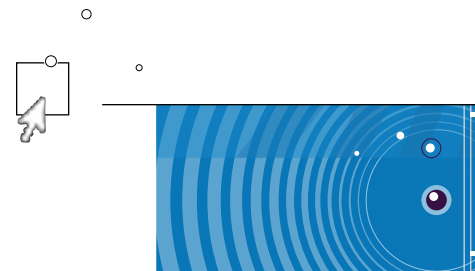

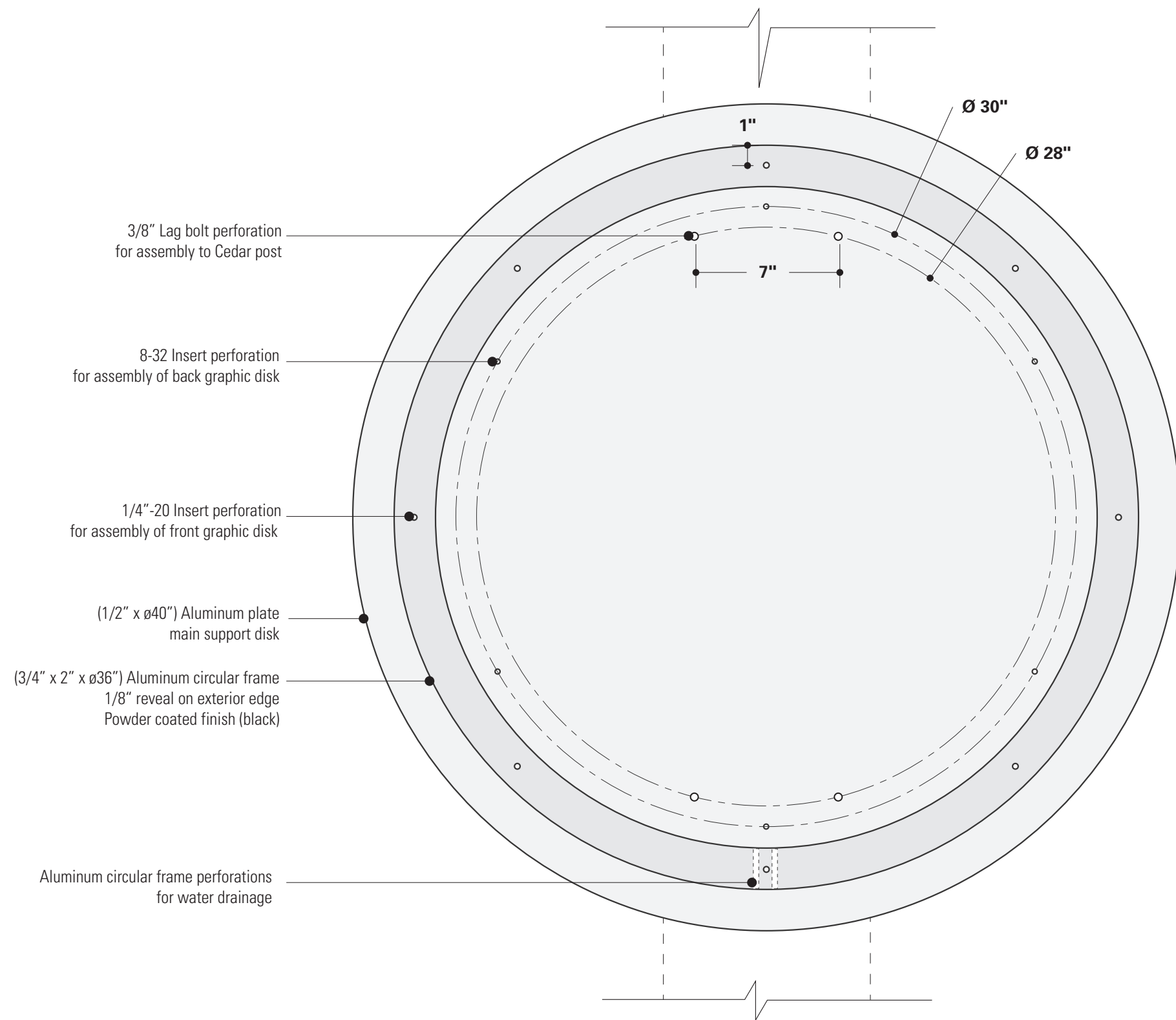

FRONT VIEW

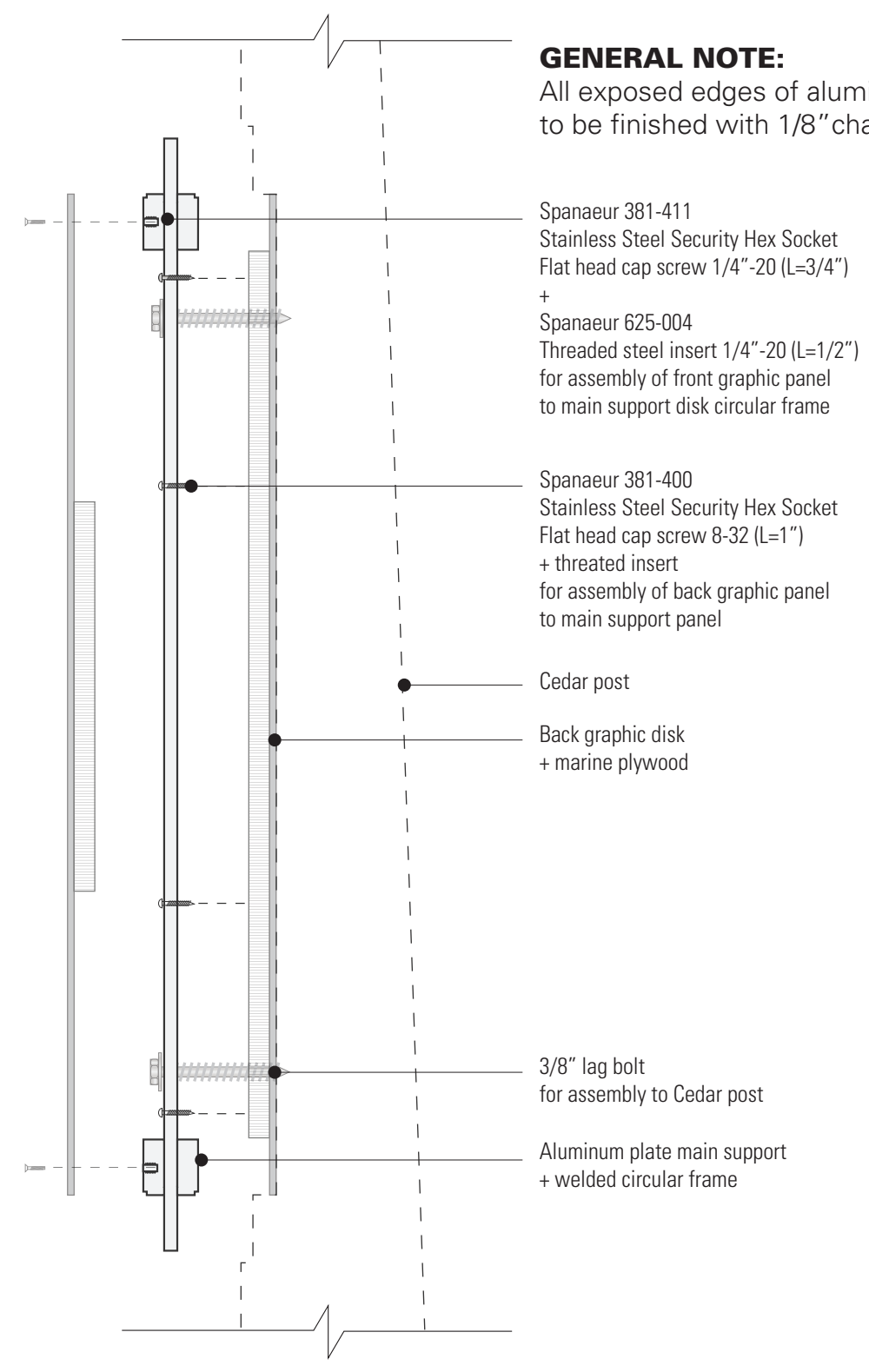

EXPLODED CROSS SECTION

GENERAL NOTE:
All exposed edges of aluminum panels to be finished with 1/8" chamfer.

Spanaeur 381-411
Stainless Steel Security Hex Socket
Flat head cap screw 1/4"-20 (L=3/4")
+
Spanaeur 625-004
Threaded steel insert 1/4"-20 (L=1/2")
for assembly of front graphic panel
to main support disk circular frame

Spanaeur 381-400
Stainless Steel Security Hex Socket
Flat head cap screw 8-32 (L=1")
+ threaded insert
for assembly of back graphic panel
to main support panel

Cedar post

Back graphic disk
+ marine plywood

3/8" lag bolt
for assembly to Cedar post

Aluminum plate main support
+ welded circular frame

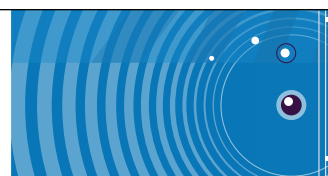
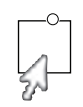

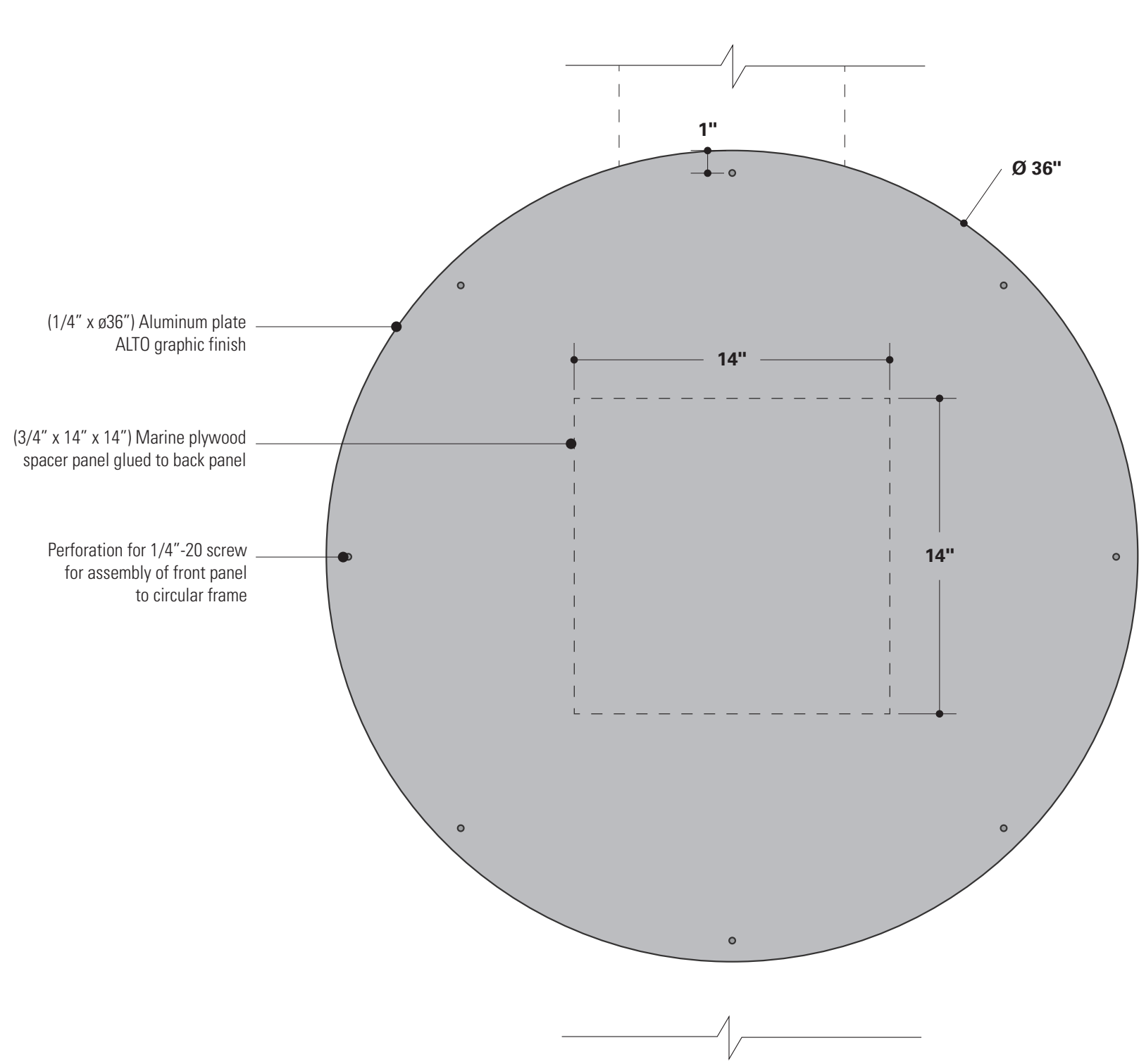

FRONT VIEW

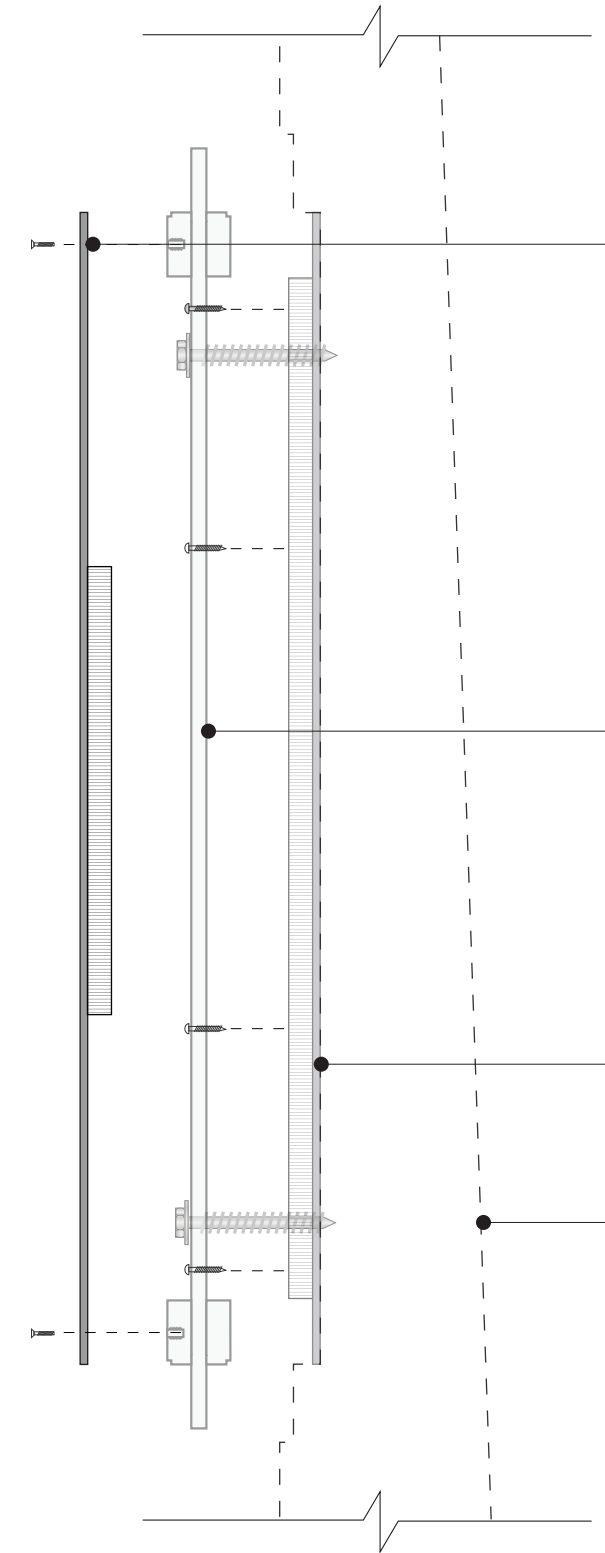

EXPLODED CROSS SECTION

GENERAL NOTE:
All exposed edges of aluminum panels to be finished with 1/8" chamfer.

- Spanaeur 381-411
Stainless Steel Security Hex Socket
Flat head cap screw 1/4"-20 (L=3/4")
- +
- Spanaeur 625-004
Threaded steel insert 1/4"-20 (L=1/2")
for assembly of front panel to main support disk

Main central support disk

(1/4" x ø36") Aluminum plate
ALTO graphic finish
+ (3/4" x 14" x 14") Marine plywood
spacer panel glued to back panel

Cedar post

(1/4" x ø36") Aluminum plate
ALTO graphic finish

(3/4" x 14" x 14") Marine plywood
spacer panel glued to back panel

Perforation for 1/4"-20 screw
for assembly of front panel
to circular frame

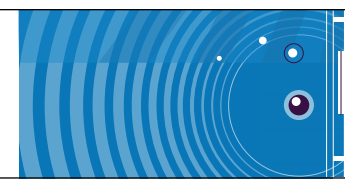
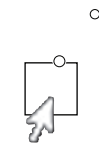

ANCHORING

assembly and details



CONCRETE BASE DETAIL

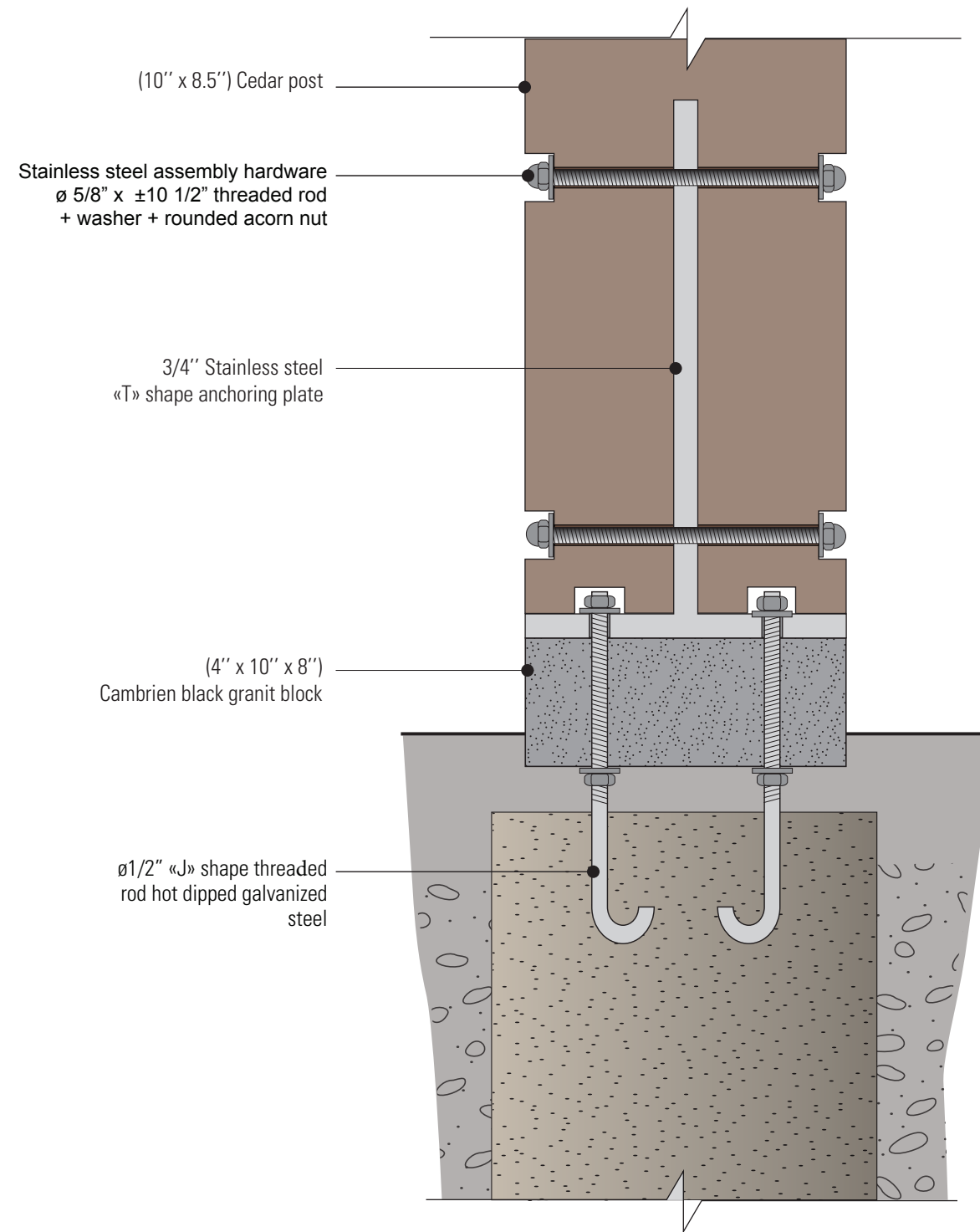

CROSS SECTION

NOTE:

Concrete base foundation and J shape threaded rod installation are not included in this contract.

Fabricator is responsible of on site measuring and producing a template in order to position accurately hole pattern on granit block, "t" shape anchoring plate and cedar post.

Fabricator is also responsible for the installation, levelling and anchoring of the wood post and interpretive support. Fabricator to guarantee physical integrity, solidity and wind load resistance of all structure, panels and fastening methods.

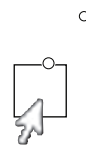

GENERAL NOTES:

1. ANY DEVIATION FROM THE CONDITIONS SHOWN ON THE DRAWINGS SHALL BE SUBMITTED TO THE ENGINEER.
2. CONTRACTOR SHALL VERIFY ALL DIMENSIONS AND ELEVATIONS PRIOR TO COMMENCING WORK. DO NOT SCALE DRAWINGS.
3. STRUCTURAL DESIGN DONE IN ACCORDANCE WITH:
 CSA S16-14 LIMIT STATES DESIGN OF STEEL STRUCTURES;
 CSA O86-14 ENGINEERING DESIGN IN WOOD;
 CSA A23.3-14 DESIGN OF CONCRETE STRUCTURES;
 HILTI ANCHOR FASTENING TECHNICAL GUIDE (2011 EDITION);
 CSA S6-14 CANADIAN HIGHWAY BRIDGE DESIGN CODE.

THESE DRAWINGS HAVE BEEN REVIEWED WITH RESPECT TO THE STRUCTURAL REQUIREMENTS OF THE ONTARIO BUILDING CODE (2012) ONLY. NON-STRUCTURAL DETAILS SHALL BE CONFIRMED BY OTHERS.

4. DESIGN LOADS (SPECIFIED):
 DEAD LOAD = 1.0 kN;
 WIND LOAD = 0.89 kPa;
 $q = 0.295 \text{ kPa}$, X_{10} YEARS (OTTAWA, ON);
 $C_e = 1.0$, $C_g = 2.5$;
 $C_h = 1.2$ (TABLE A3.2.2: SIGN PANELS AND NOISE BARRIERS).

5. MATERIALS:
 CONCRETE:
 FOOTING & PEDESTAL, $f'_c = 20 \text{ MPa}$, CLASS F-2;
 REINFORCING STEEL, CSA G30.18 400R (OR 400W);
 STRUCTURAL STEEL:
 MISC. STEEL, CSA G40.21 GRADE 300W;
 WELDING, CSA W59-03, ELECTRODE E49XX;
 STEEL CARRIAGE BOLTS, NUTS AND WASHERS, ASTM A307, GRADE A,
 HOT DIPPED GALVANIZED (HDG);
 ANCHOR BOLTS HEAVY HEX HEAD, ASTM F1554 GRADE 36;
 HILTI HIT-HY 200 SAFE SET ADHESIVE ANCHORING SYSTEM.

6. ARRANGEMENT, GEOMETRY AND CONDITIONS WITH THE EXISTING STRUCTURE ARE ASSUMED TO BE AS INDICATED IN PANNEAUX D'INTERPRETATION PARC ANISHINABLE CÔTÉ EST (DATED MARCH 31, 2016).
7. PROPRIETARY PRODUCTS (INCLUDING HILTI EPOXY) SHALL BE INSTALLED AS PER THE MANUFACTURER'S INSTRUCTIONS.
8. ALL STRUCTURAL STEEL, METAL FASTENERS, AND ACCESSORIES SHALL BE HOT DIPPED GALVANIZED AS PER ASTM A123 AND ASTM A153.
12. WELDERS SHALL BE CERTIFIED BY THE CANADIAN WELDING BUREAU TO THE REQUIREMENTS OF CSA STANDARD W47.1.
13. CONCRETE SHALL BE PLACED IN CONFORMANCE TO CSA A23.1. CLEAR COVER TO REINFORCING STEEL SHALL BE 3" IN ALL LOCATIONS.
14. THESE DRAWINGS SHOW THE FOOTING AND ANCHORAGE CONNECTIONS ONLY. THE STRUCTURAL COMPONENTS OF THE SIGN SHALL BE CONFIRMED BY OTHERS.
15. REINFORCING STEEL AND ANCHORAGE SYSTEMS SHALL BE INSPECTED BY THE ENGINEER PRIOR TO COVERING.

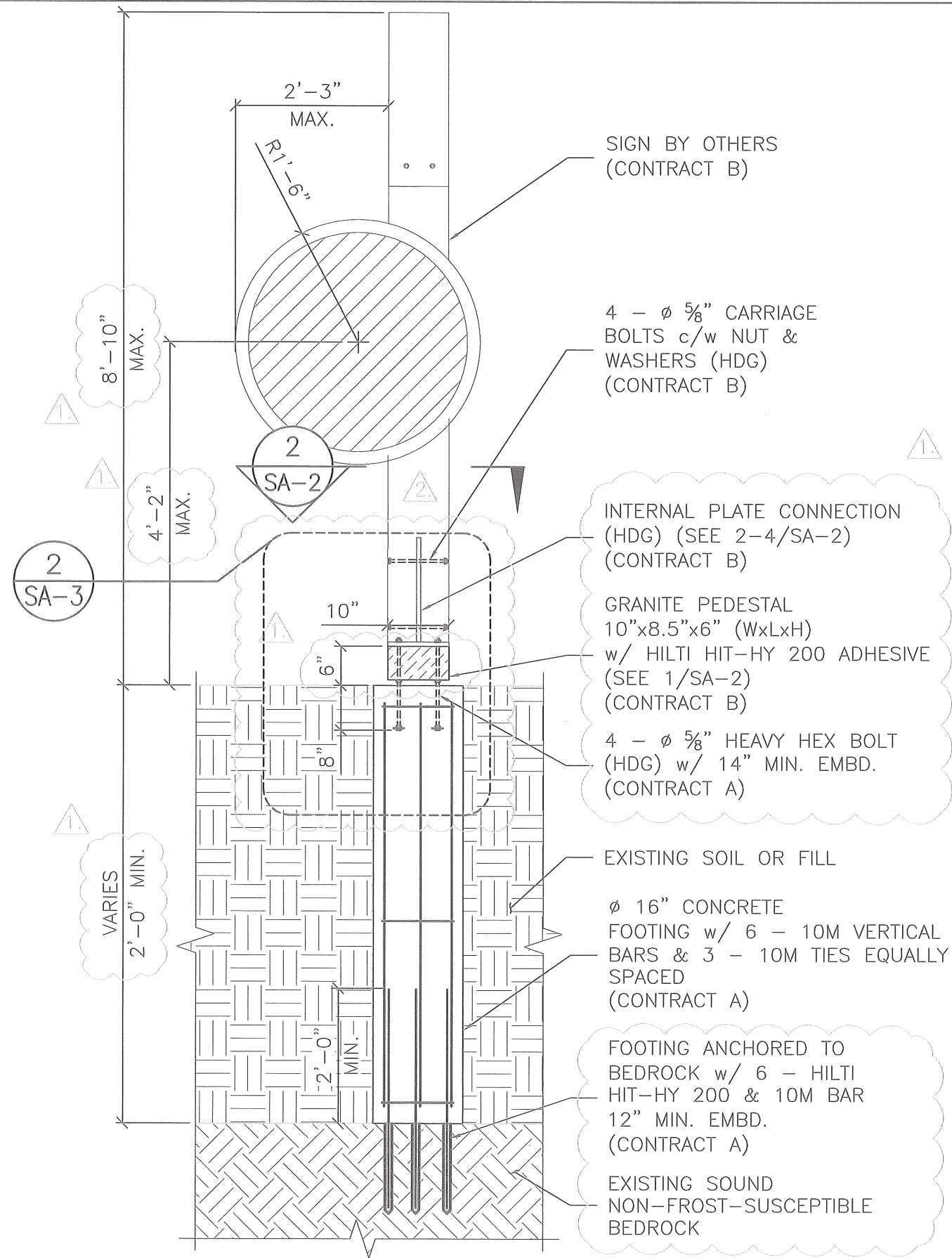

1
SA-1 SIGN FOUNDATION
1/2"=1'-0" ELEVATION

client
VISOU DESIGN

art engineering inc.
 171 Wolgreen Road
 Carp • Ontario • K0A 1L0 • Canada
 (613) 626-0632 • Fax (613) 636-1226
 www.artengineering.ca

scale 1/2" = 1'-0"

2.	REVISED	09-05-16
1.	REVISED	14-04-16
0.	FOR CLIENT'S REVIEW	13-04-16

revisions

A detail no. no. de détail
B location drawing no. sur dessin no.

project
ANISHINAABE SIGN FOOTING & ANCHORAGE
 PARC DES PLAINES LEBRETON:
 CÔTÉ EST OTTAWA, ON

drawing
GENERAL NOTES & ELEVATION

LICENSED PROFESSIONAL ENGINEER
D. F. Weidlich
D. F. WEIDLICH
 100175002
 09-MAY-2016
 PROVINCE OF ONTARIO

designed	J.I.B.	reviewed	J.S.
drawn	J.I.B.	approved	D.W.
date	May 9, 2016		
project number	3505	drawing number	SA-1

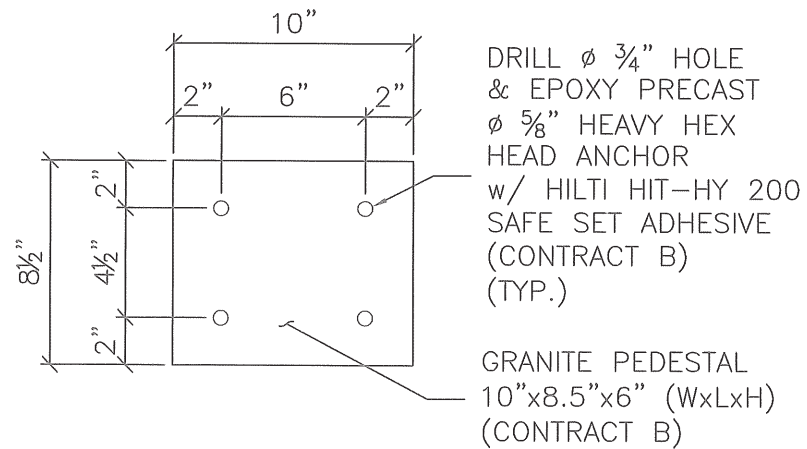

1 GRANITE PEDESTAL
SA-2 1-1/2"=1'-0" PLAN DETAIL

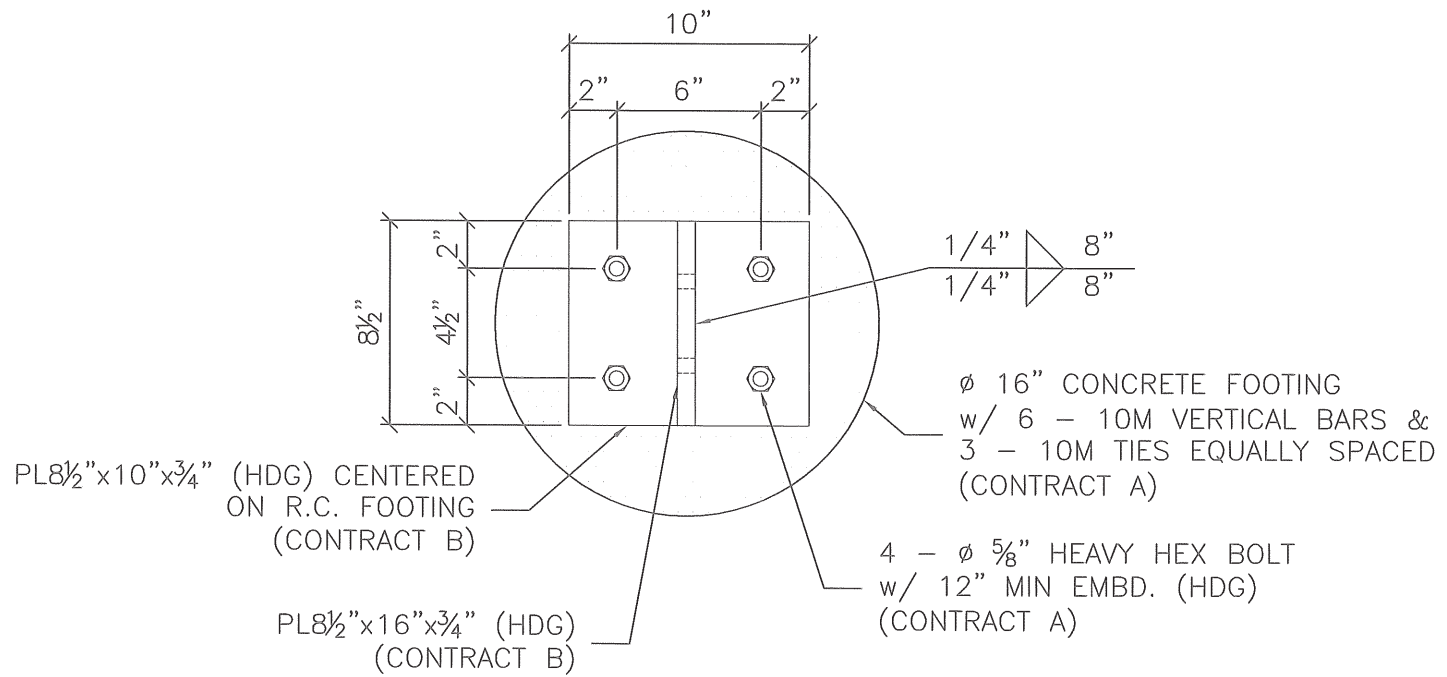

2 INTERNAL PLATE
SA-2 1-1/2"=1'-0" PLAN DETAIL

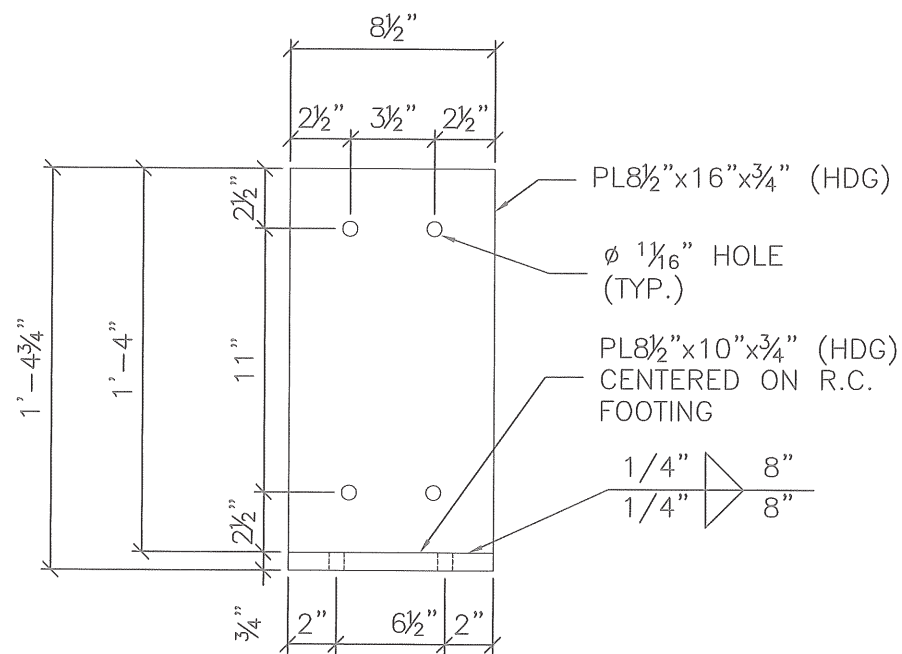

3 INTERNAL PLATE
SA-2 1-1/2"=1'-0" SIDE DETAIL

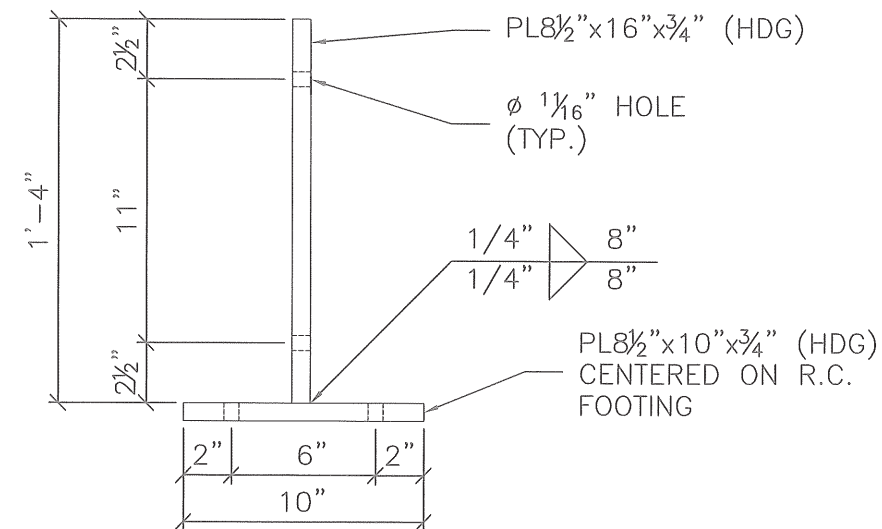

4 INTERNAL PLATE
SA-2 1-1/2"=1'-0" FRONT DETAIL

client

VISOU DESIGN



scale 1-1/2" = 1'-0"

revisions	date
2. REPRINTED	09-05-16
1. REVISION	14-04-16
0. FOR CLIENT'S REVIEW	13-04-16

A	A detail no. no. de détail
B	B location drawing no. sur dessin no.

project

ANISHINAABE SIGN FOOTING & ANCHORAGE
PARC DES PLAINES LEBRETON:
CÔTÉ EST OTTAWA, ON

drawing

INTERNAL PLATE CONNECTION DETAILS

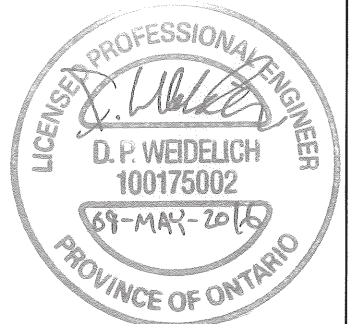

designed J.I.B.	reviewed J.S.
drawn J.I.B.	approved D.W.
date May 9, 2016	
project number 3505	drawing number SA-2

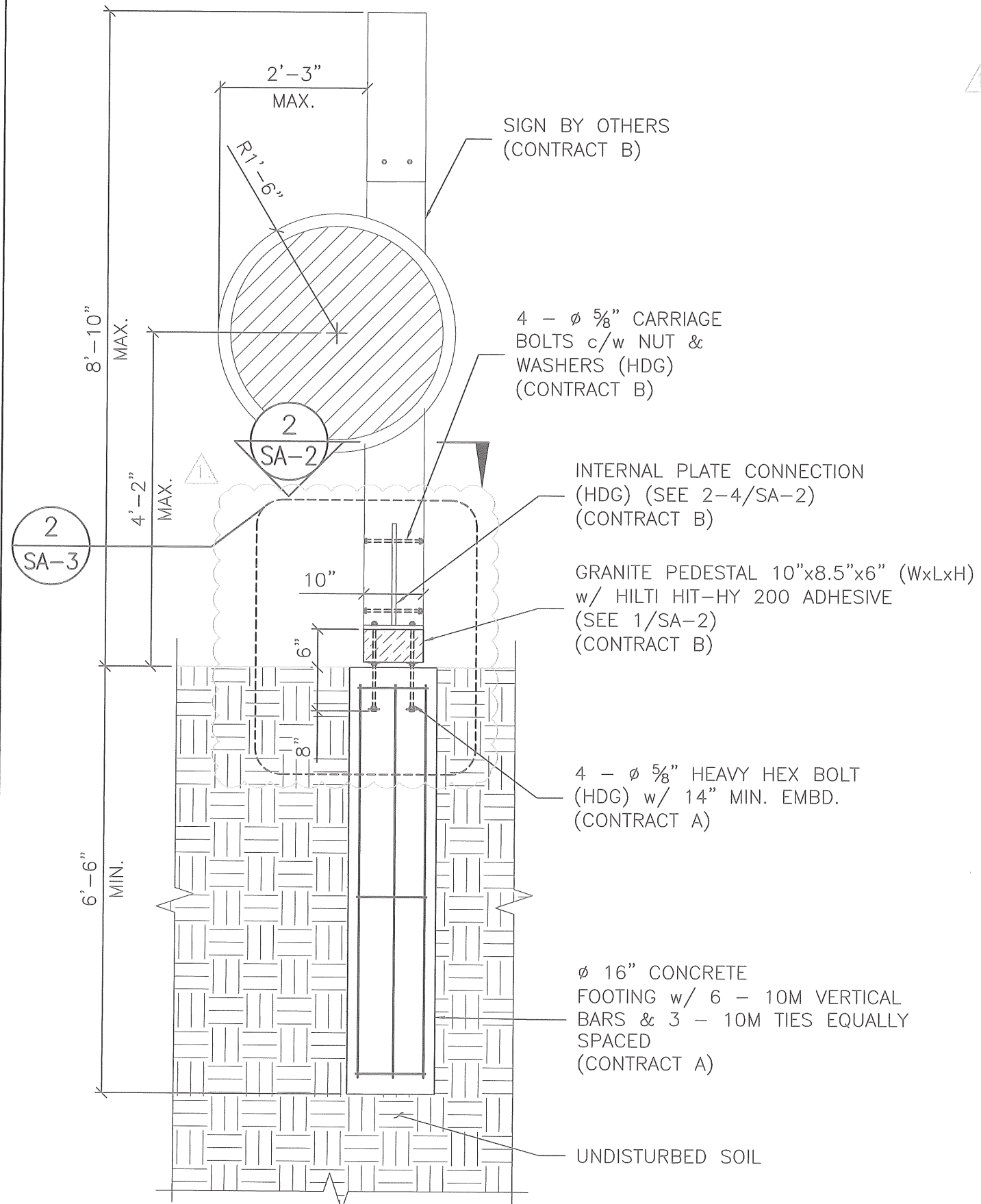

1 OPTION 2: SIGN FOUNDATION
 SA-3 1/2"=1'-0" ELEVATION

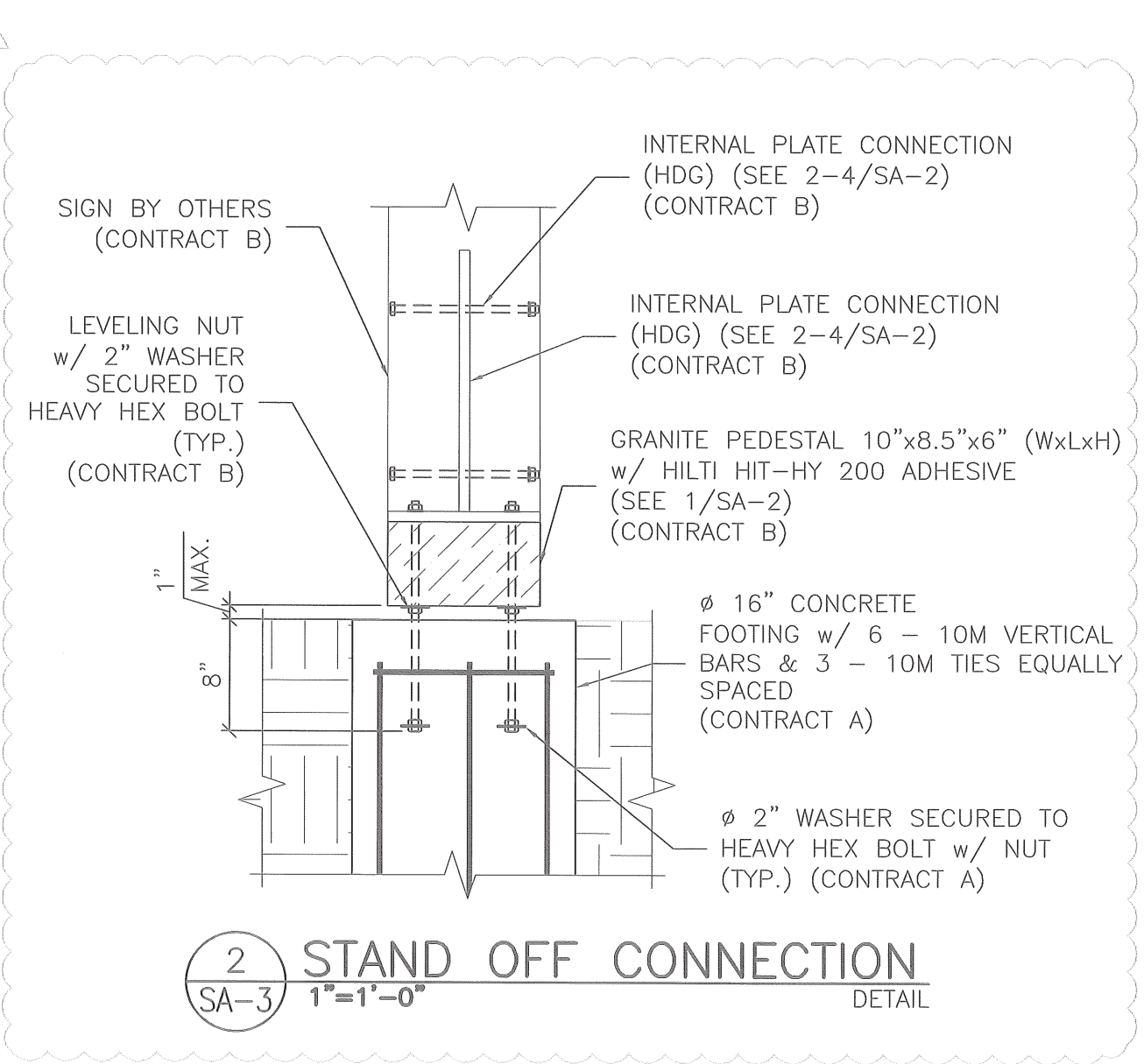

2 STAND OFF CONNECTION
 SA-3 1"=1'-0" DETAIL

client
VISOU DESIGN



scale 1/2" = 1'-0"

1.	REVISION	09-05-16
0.	FOR CLIENT'S REVIEW	19-04-16
revisions		date

A A detail no. no. de détail
B B location drawing no. sur dessin no.

project
ANISHINABE SIGN FOOTING & ANCHORAGE
 PARC DES PLAINES LEBRETON:
 CÔTÉ EST OTTAWA, ON

drawing
OPTION 2: SIGN ELEVATION



designed	J.I.B.	reviewed	D.W.
drawn	J.I.B.	approved	D.W.
date	April 19, 2016		
project number	3505	drawing number	SA-3

3D MODEL

general views and details



FOR REFERENCE ONLY

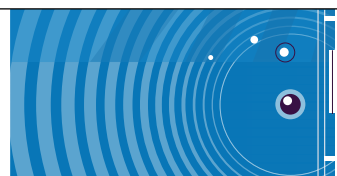
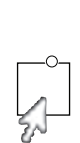

FOR REFERENCE ONLY

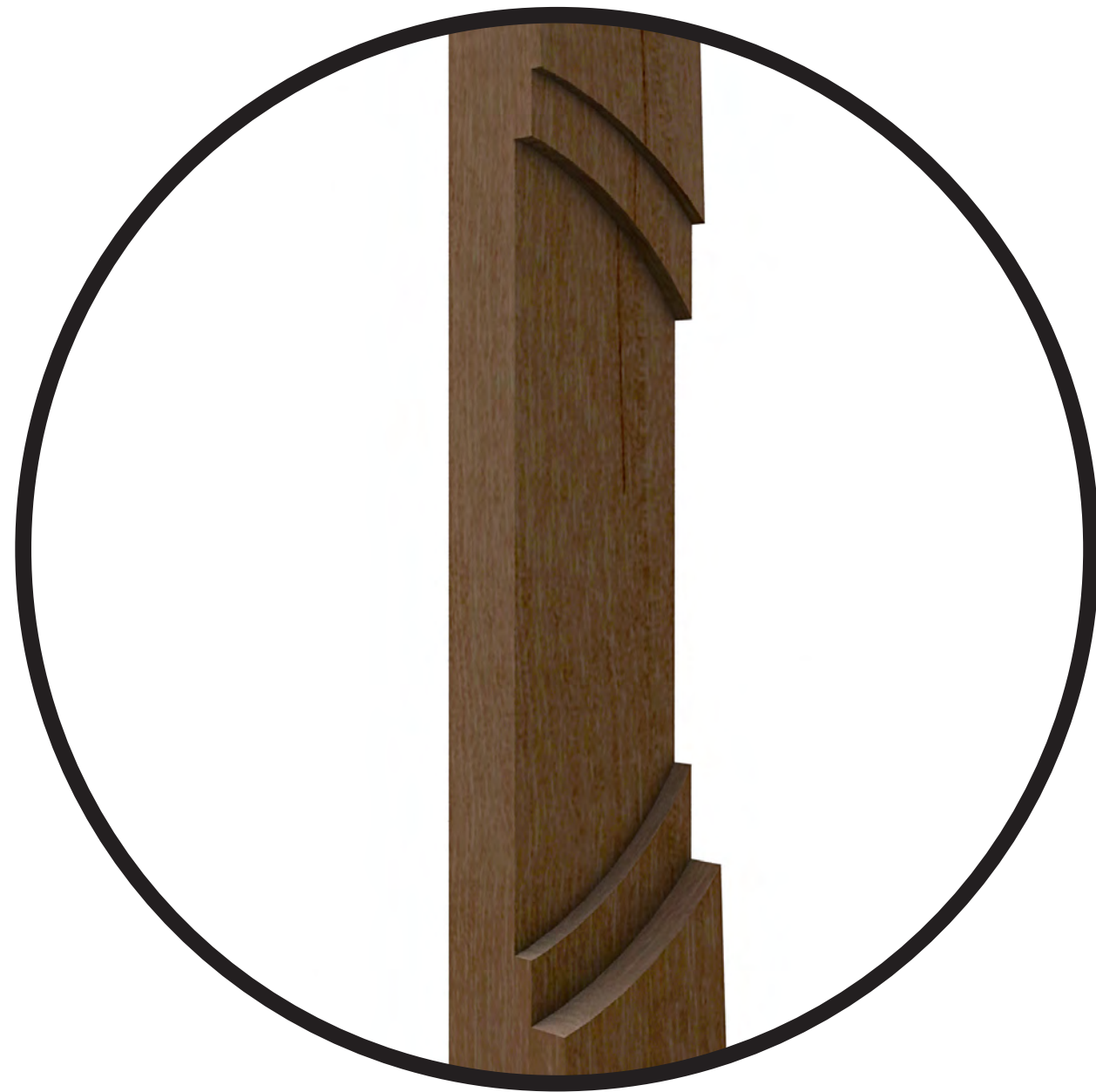

CEDAR POST
ENGRAVING DETAILS



ASSEMBLY DETAIL OF
GRAPHIC PANEL TO CEDAR POST

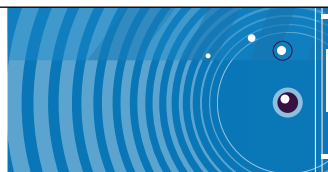
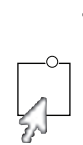

FOR REFERENCE ONLY



TOP ENGRAVING DETAIL



BOTTOM ENGRAVING DETAIL

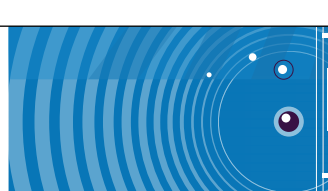
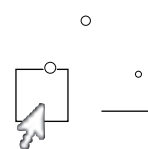

RUE BOOTH STREET

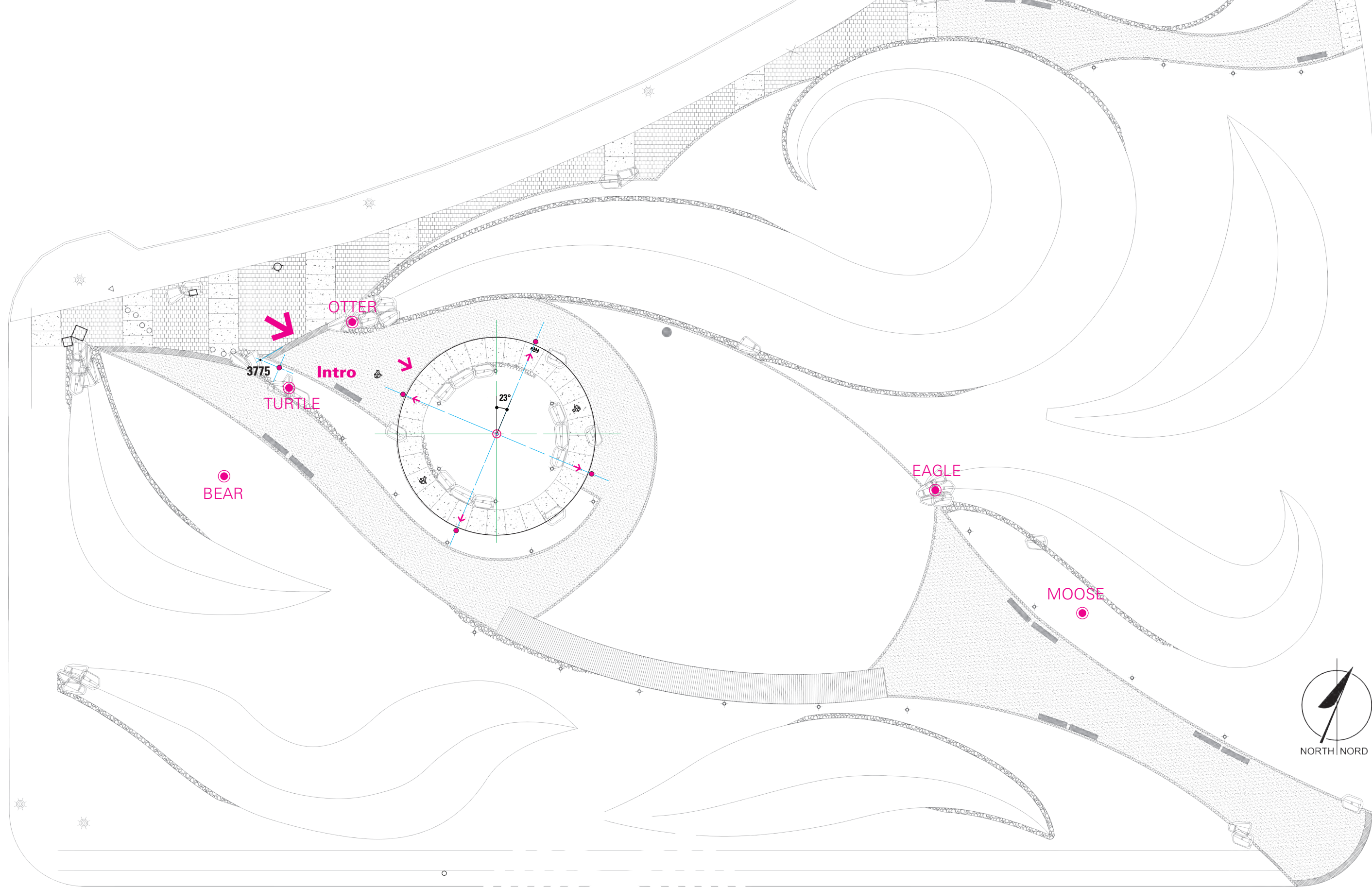

RUE FLEET STREET



NOTES
Phase 2
For Reference Only
Measurements to be validated on site

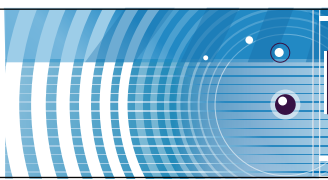

l'idée projetée dans la forme

NOM DU PROJET / PROJECT NAME
**Interpretive Panels
Anishinabe Park
East Side**

TITRE DU DESSIN / DRAWING TITLE
**Plan de site
localisation des
supports
interprétation**

INFORMATIONS
DATE: **31/03/2015**
DRAWN BY: **Frédéric St-Laurent**
VERIFIED BY: **Frédéric St-Laurent**
SCALE: **n.a.**

FEUILLE #
03