

APPROXIMATE LINE OF EXISTING WILDLIFE FENCE.

EXISTING SERVICE ROAD

AC-3 (COUGAR TO FACE AWAY FROM MOOSE)

EXISTING LANDSCAPING ROCK RETAINED

EXISTING LANDSCAPING ROCK RETAINED

PROPOSED GARAGE CAN.
 8.5m
 PROPOSED PICNIC SHELTER
 * 0.1m x 1m x 1m CONCRETE PAD TO BE FOUNDED WITH CABLE LOOP AND TO BE BURIED UNDER GRADER AT A DEPTH OF 0.3M CHAIN GRADER TO PAD AND FINISH WITH GRAVEL UNDER GRADER.

INTERPRETIVE SIGN LIST

- INTERPRETIVE PANELS**
- IP-1 "A ROAD FOR B.C., A PARK FOR CANADA"
 - IP-2 "A PARK DIVIDED"
 - IP-3 "SAFE PASSAGES"
 - IP-4 "ESCAPE HATCHES"
 - IP-5 "HOW DID THE FISH CROSS THE ROAD?"
 - IP-6 "MORE TO SEE & DO"
- ANIMAL TRACKS**
- AT-1 BLACK BEAR AND RELATED PAVES
 - AT-2 WOLF AND RELATED PAVES
 - AT-3 DEER AND RELATED PAVES
 - AT-4 DOLLY VARDEN AND RELATED PAVES

- VEHICLE CUTOUTS**
- VC-2 MODEL T FORD
 - VC-3 VW BEETLE
 - VC-4 TRAMS
- ANIMAL CUTOUTS**
- AC-1 MOOSE (MOUNTED OUTSIDE WILDLIFE FENCE)
 - AC-1B MOOSE SUBSIGN
 - AC-2 DEER (MOUNTED ON FENCE)
 - AC-3 COUGAR (MOUNTED OUTSIDE WILDLIFE FENCE)
 - AC-3B COUGAR SUBSIGN
 - AC-4 WOLF (MOUNTED ON FENCE)
 - AC-5 DOLLY VARDEN (MOUNTED ON FENCE)
 - AC-6 BLACK BEAR (MOUNTED ON POST AT JUMP OUT)

- ACTIVITIES PANELS**
- EP-2 "HEY KIDS" (MOUNTED ON PICNIC TABLES) X12
 - EP-3 DOLLY VARDEN CUT OUTS (MOUNTED IN CULVERT) X6
 - EP-4 "HOW FAR CAN YOU LEAP?"
 - EP-5 "HOW FAR CAN YOU JUMP?"
 - EP-6 "HOW FAST CAN YOU RUN?"

LANDSCAPING NOTES
 USE LARGE RIPRAP FOR UNDERPASS RETAINING WALLS. PRICKLY SHRUBS (SUCH AS JUNIFER) TO BE PLANTED ALONG BASE OF RIP RAP WALL TO DETER GUMMING. ENTIRE SITE TO BE SOAKFIELD AND HYDROSEEDING AFTER CONSTRUCTION. AREA UNDER STEPPING STONES TO BE EXCAVATED TO 1/2 STONE DEPTH & COMPACTED. AREA IN UNDERPASS TO BE FINISHED WITH 150MM DEPTH GENVEL ON LANDSCAPING CLOTH. LAD OVER 300MM MINIMUM DEPTH OF DEBRIS ROCK. JUMP OUT FINISHED WITH 50MM DEEP, BROWN COLOURED GUMFLE PAD.

DOLLY VARDEN DUA

SCALE: 1:125M	APPROVED BY:	DRAWN BY D, GUNN
DATE: AUG. 2016		REVISED
WILDLIFE UNDERPASS EXHIBIT		
PROPOSED SITE PLAN		DRAWING NUMBER A1

* DO NOT SCALE OFF DRAWING. USE WRITTEN DIMENSIONS ONLY. CROSS-REFERENCE THIS DRAWING WITH GRAPHIC MATERIAL FROM METROGRAPHICS AND SPECIFICATIONS FROM CANADA CULVERT.

POST

2.4m LONG PRESSURE-TREATED PINE OR SPRUCE PENNUL POSTS. EACH POST BURIED 900MM IN GROUND WITH READY MIX POURED AROUND BASE. FINISHED WITH WELL-COMPACTED, NON-ORGANIC FILL.

WIRE

1.2m ROLL GALVANIZED FENCE WIRE WITH 1" MESH. SECURED WITH GALVANIZED STAPLES.

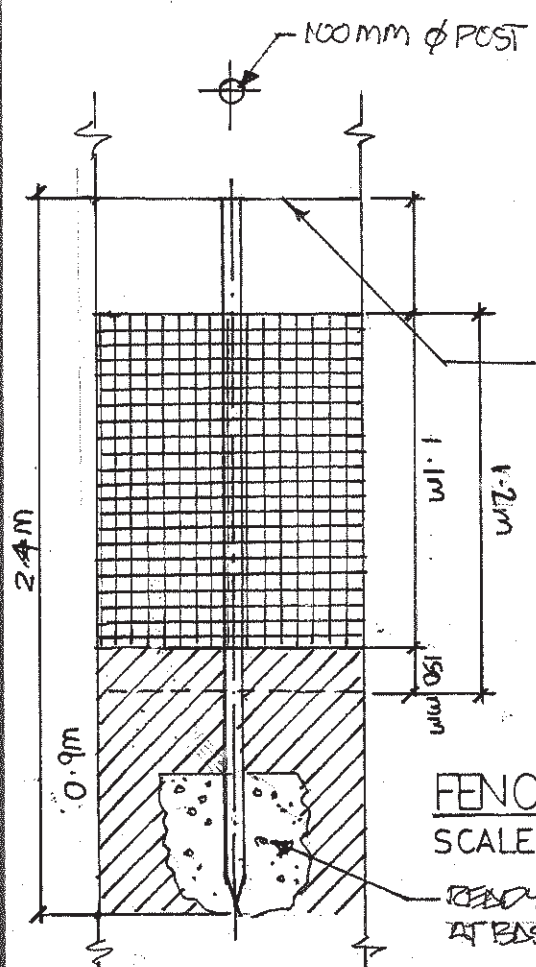

FENCE POST DETAIL
SCALE 1:25

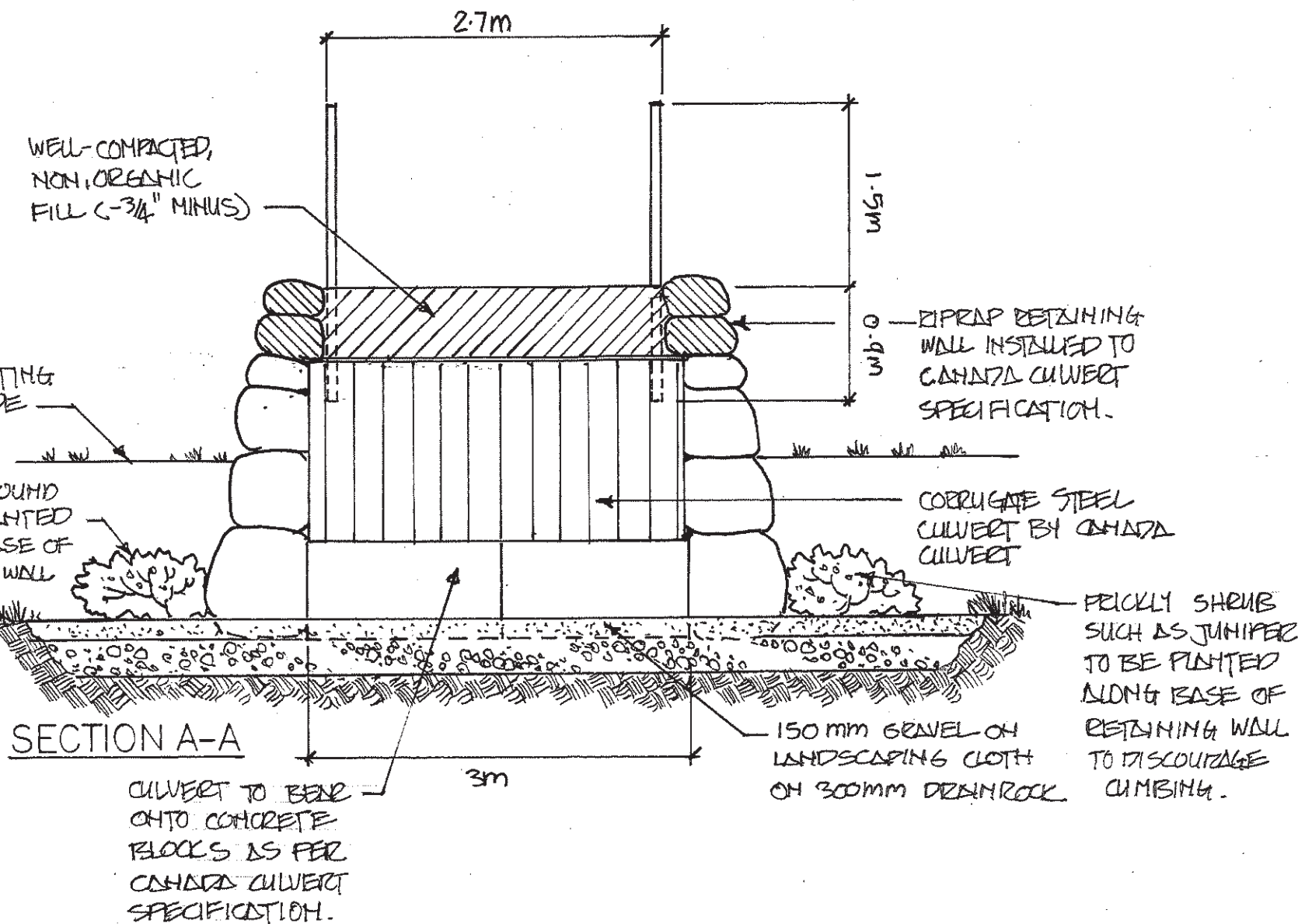

SECTION A-A

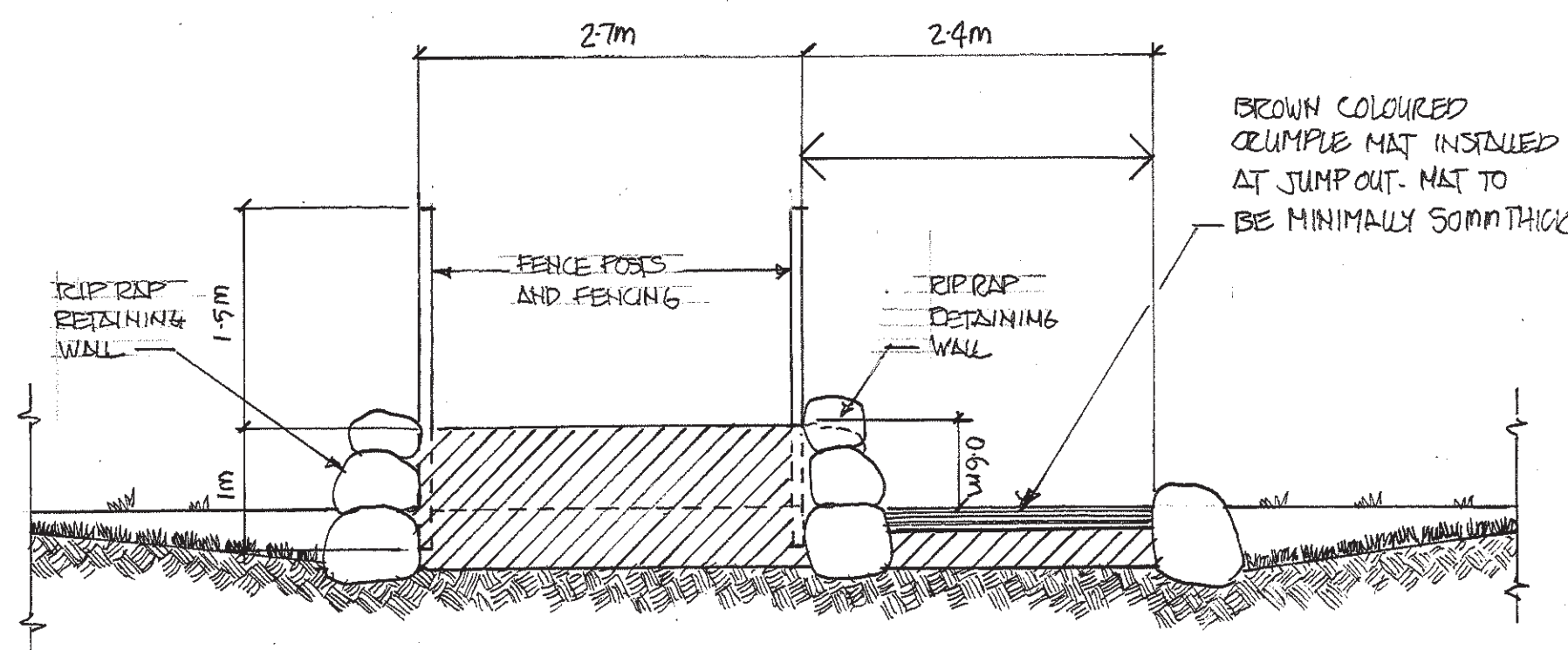

SECTION B-B

CULVERT
CULVERT TO BE 1.6m HIGH X 3M WIDE AT BASE AND 3M LONG. CULVERT TO BE FROM CANADA CULVERT AND INSTALLED AS PER MANUFACTURER'S PRINTED INSTRUCTIONS.

ALL NEW CONSTRUCTION TO BEAR ONTO WELL-COMPACTED, NON-ORGANIC SOIL OR BEDROCK.

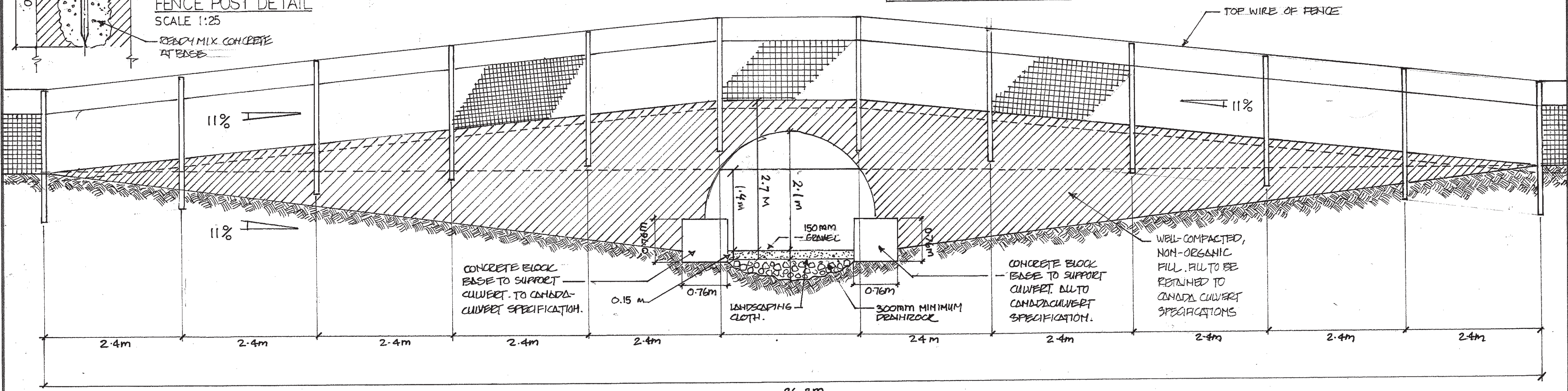

SECTION C-C

IT IS ANTICIPATED THAT PEAK USAGE OF EXHIBIT WILL HAPPEN AT DRIEST TIME OF YEAR WHEN THERE IS MINIMAL RISK OF FLOODING.

*CONCRETE BLOCKS TO BEAR ONTO WELL-COMPACTED NON-ORGANIC SOIL OR ROCK.

DOLLY VARDEN D.U.A.		
SCALE: 1:50(M)	APPROVED BY:	DRAWN BY D GUNN
DATE: AUG. 2016		REVISED
WILDLIFE UNDERPASS EXHIBIT		
SECTIONS:		DRAWING NUMBER
		A3

DO NOT SCALE OFF DRAWING. USE WRITTEN DIMENSIONS ONLY. THIS DRAWING TO CROSS-REFERENCE WITH SPECIFICATIONS FROM METROGRAPHICS AND CANADA CULVERT.

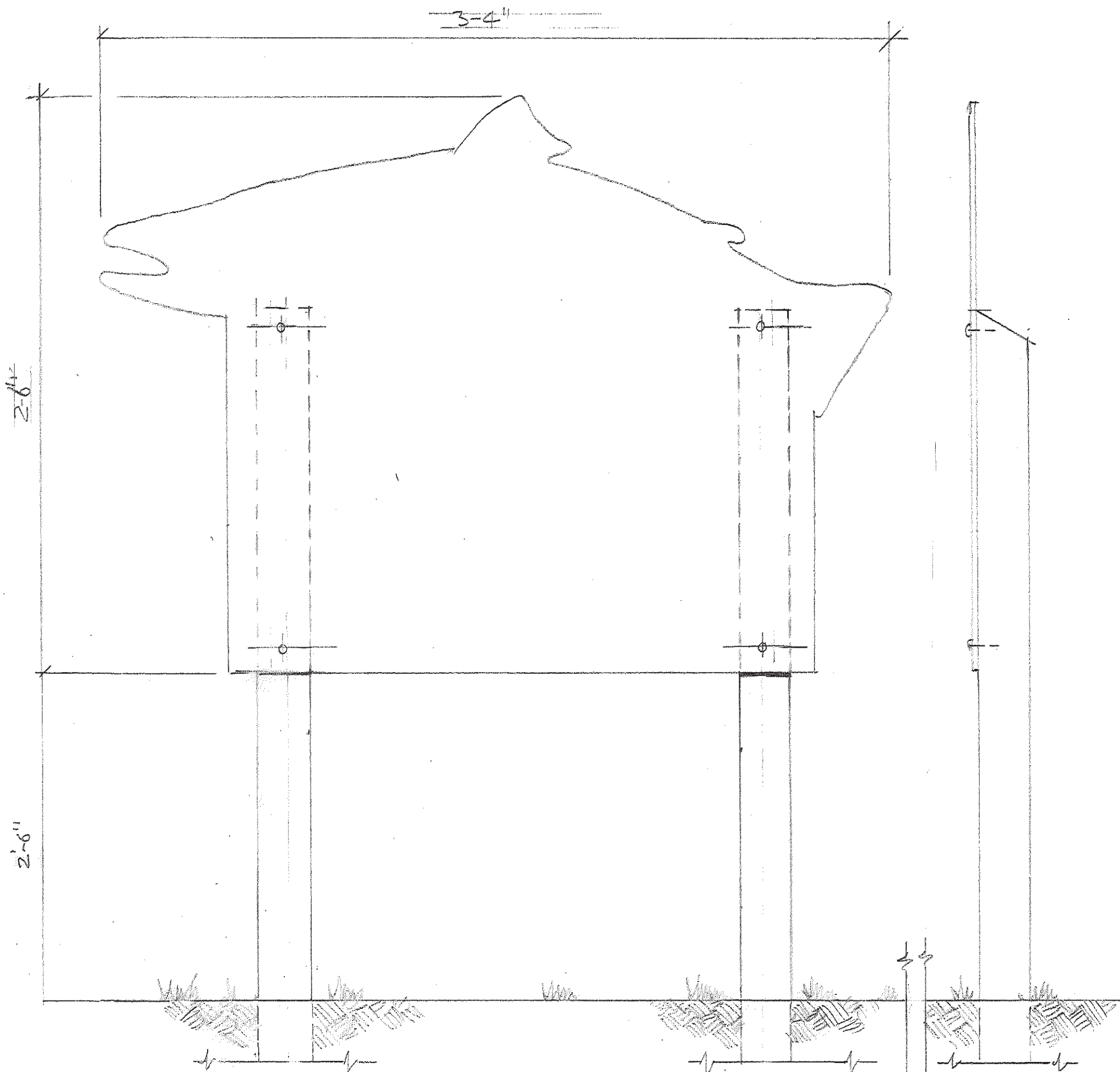

IP-5 "HOW DID THE FISH CROSS THE ROAD?"

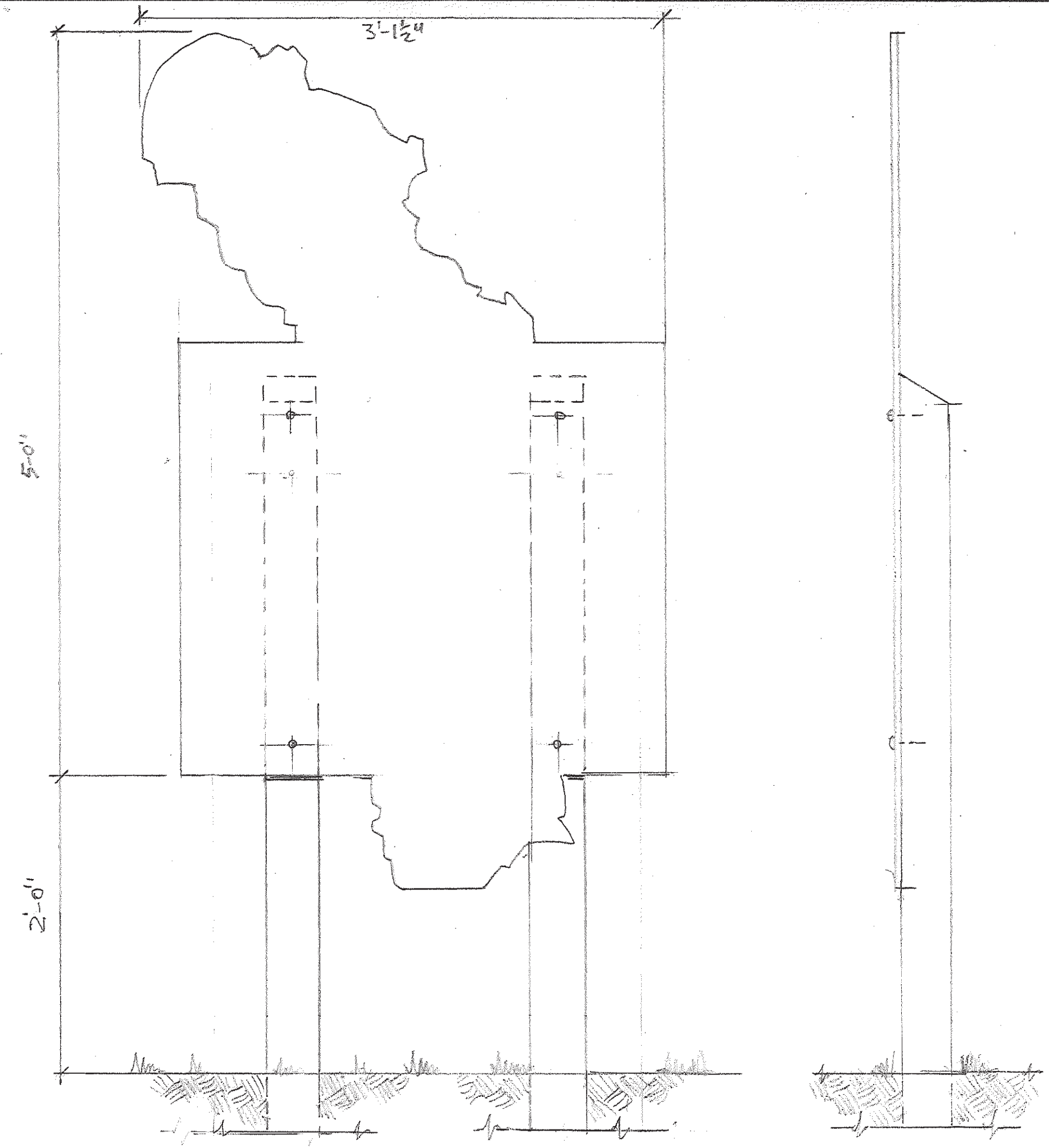

IP-6 "MORE TO SEE & DO."

DOLLY VARDEN DAY USE AREA

SCALE:	APPROVED BY:	DRAWN BY:
DATE:		REVISED:
		DRAWING NUMBER:

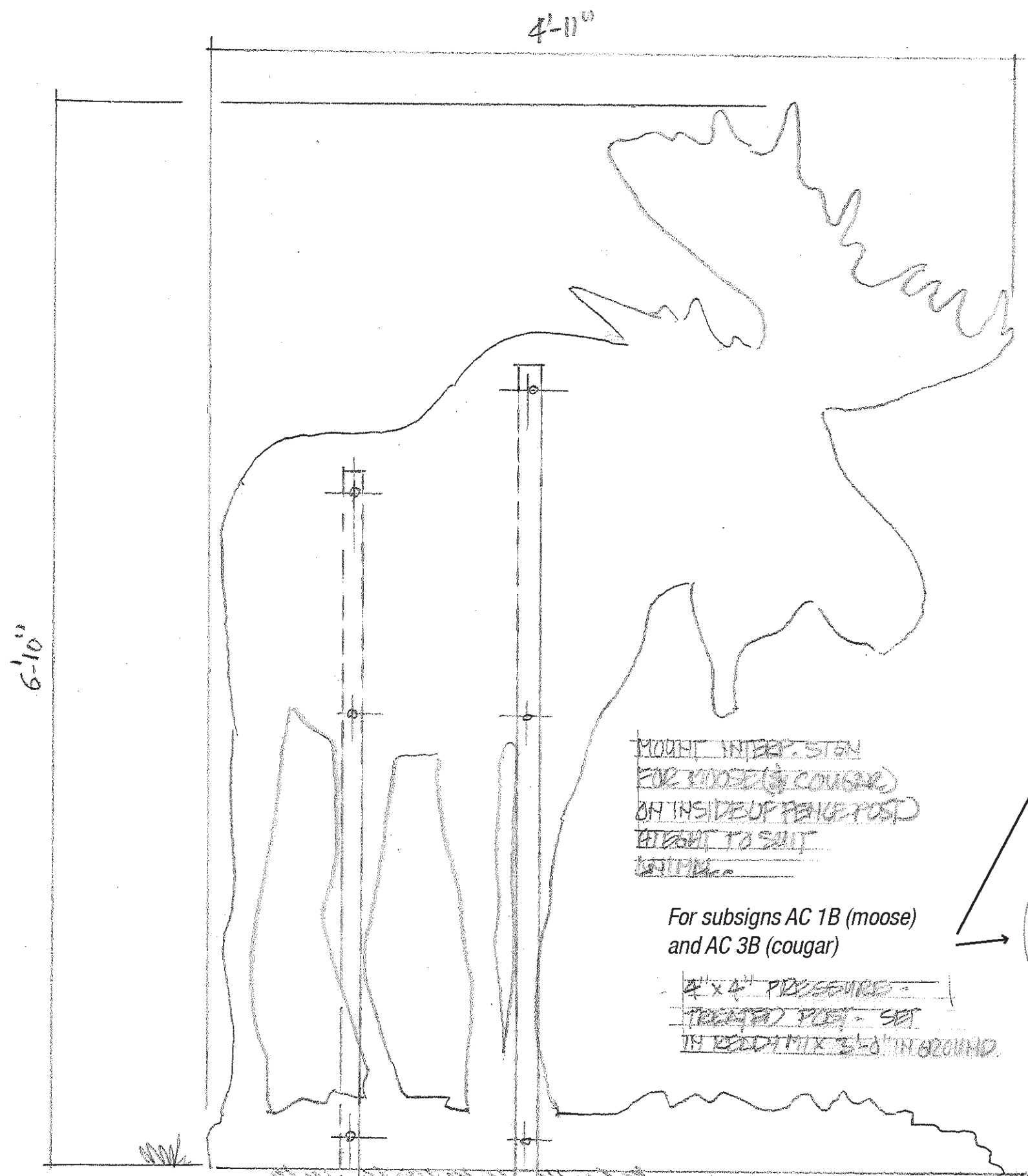

MOUNT INTERP. STAIN
FOR MOOSE (COUGAR)
ON INSIDE OF FENCE POST
TIGHT TO SPLIT
SPLITTING

For subsigns AC 1B (moose)
and AC 3B (cougar)

2" x 4" PIPE SQUARE -
TREATED POST - SET
IN RED MIX 3'-6" IN GROUND

AC-1 "MOOSE" (MOUNTED OUTSIDE
WILDLIFE FENCE)

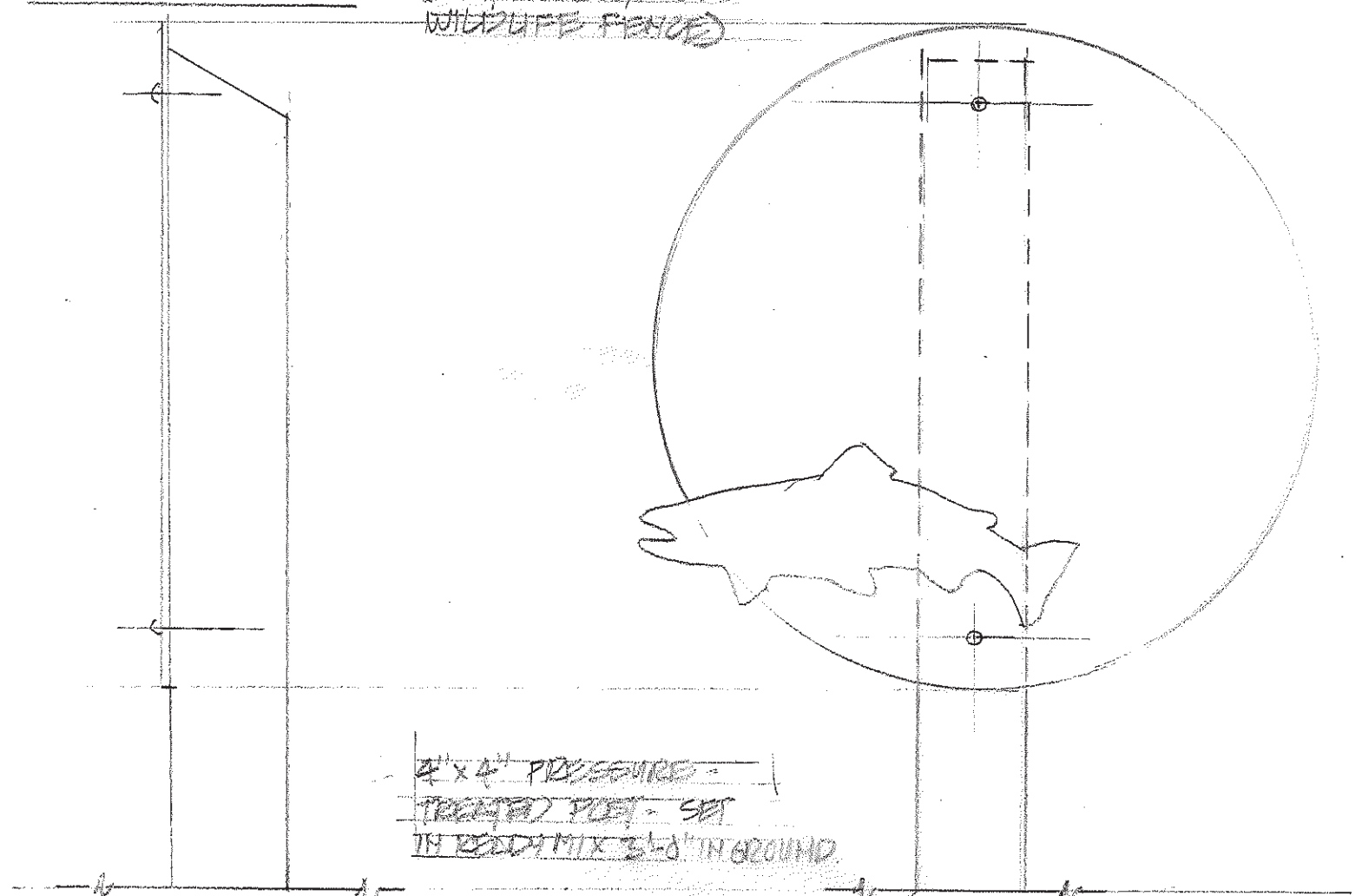

2" x 4" PIPE SQUARE -
TREATED POST - SET
IN RED MIX 3'-6" IN GROUND

AC-5 "GOODBYE MOOSE"

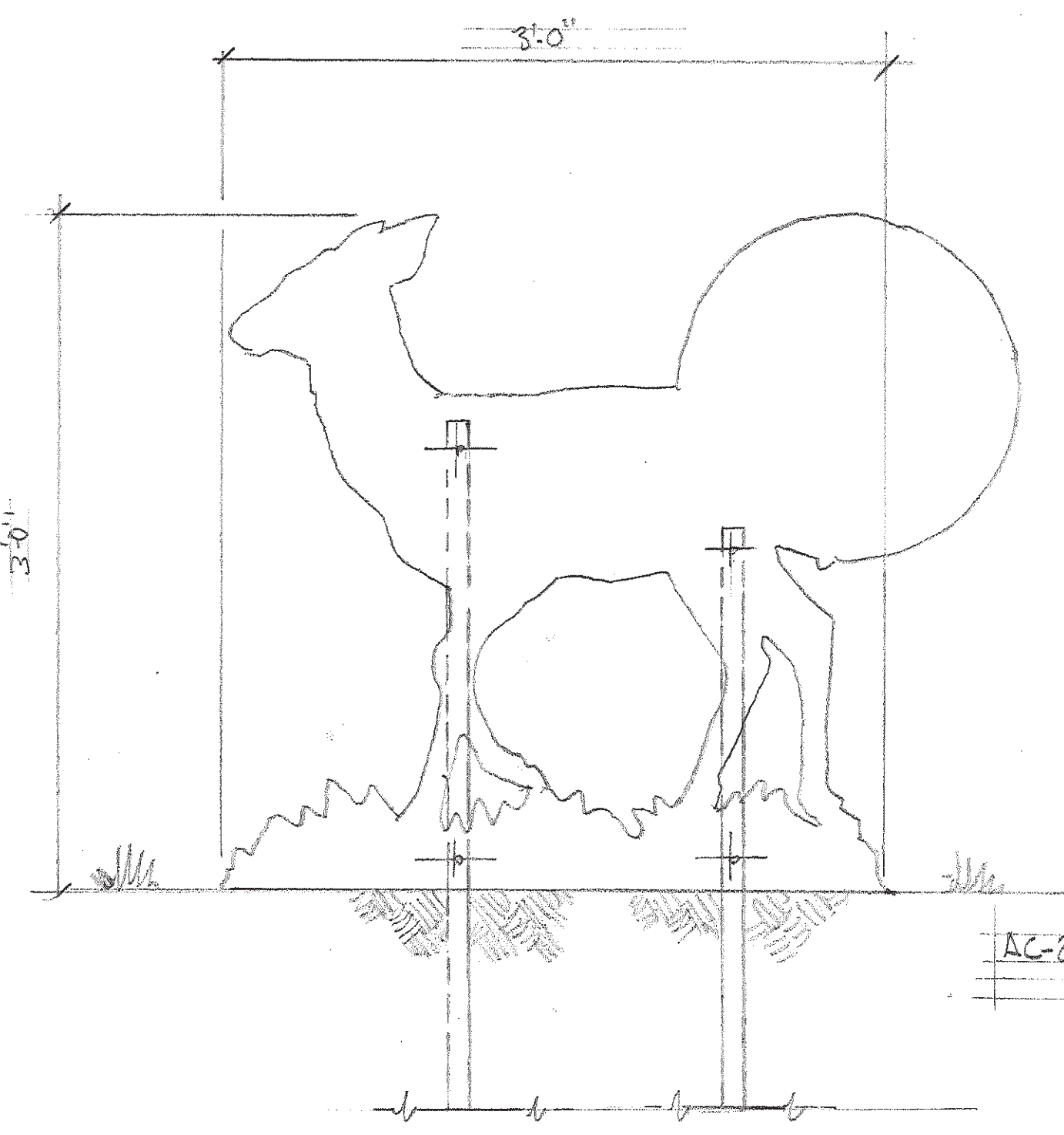

AC-2 "DEER"

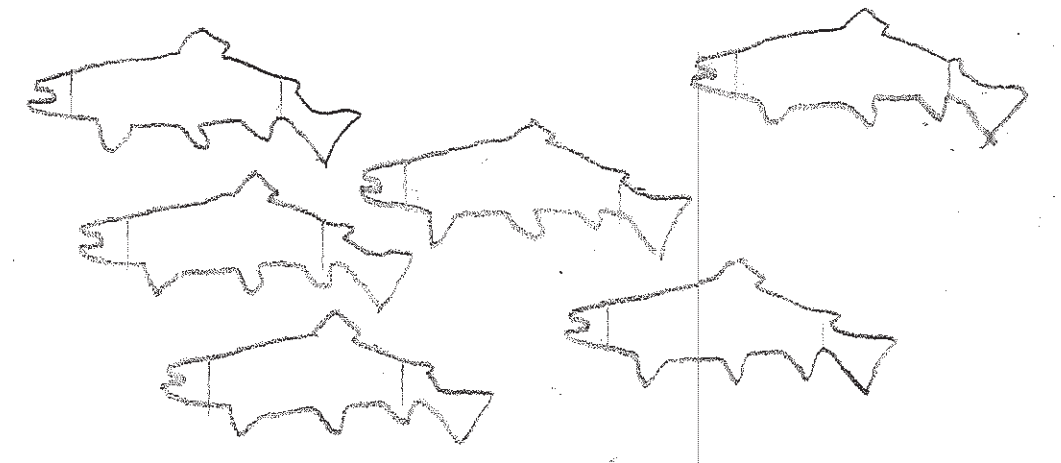
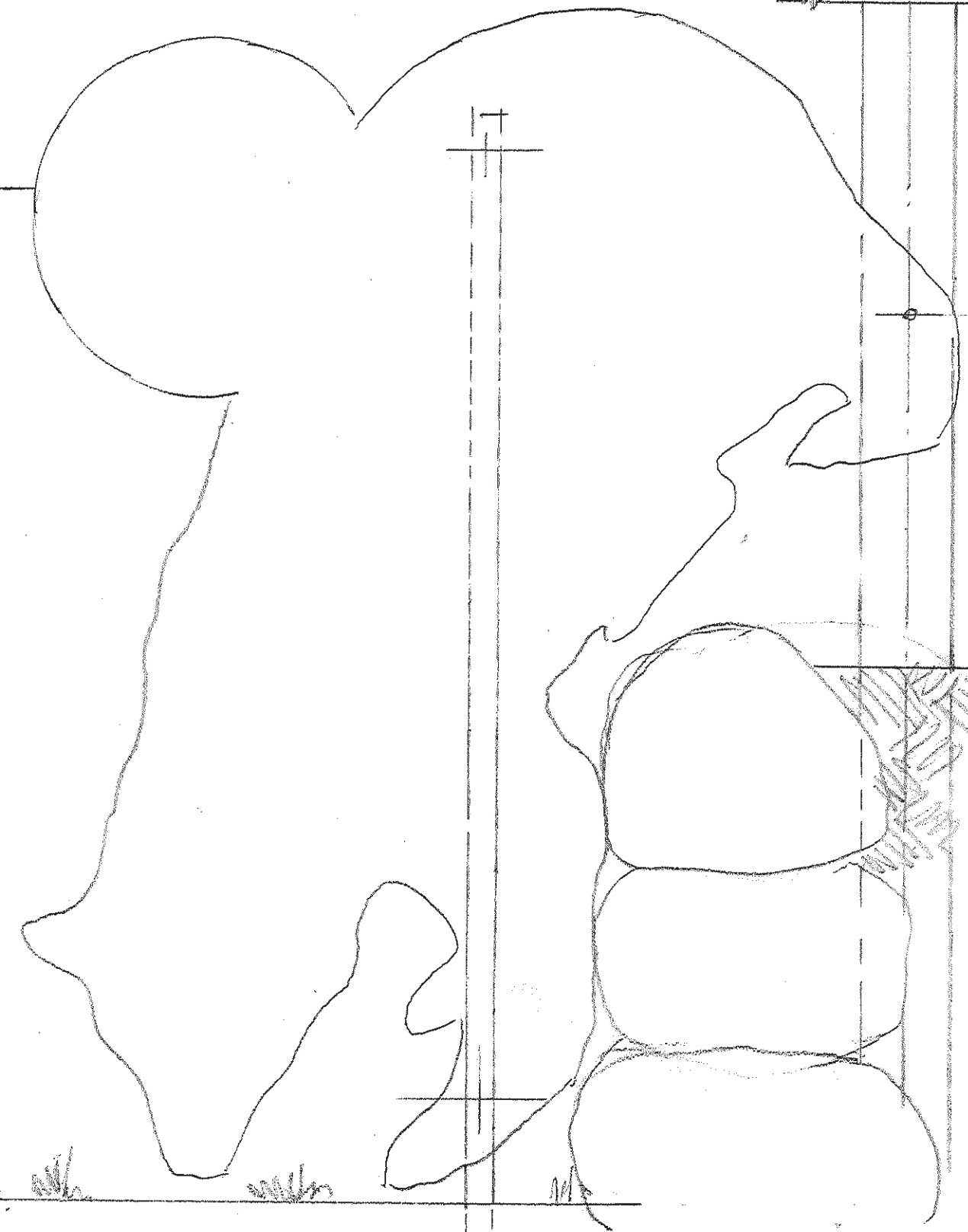

AC-3 "FULLY VARNISHED"

MOUNT TO INSIDE OF CULVERT USING
STAINLESS STEEL TAMPED POINT SCREWS.
LOCATION OF SCREW TO SUIT CULVERT RIPS.

AC-6 "BULL BEEF"
MOUNT AT JUMP OUT

FULLY VARNISHED ONLY USE AREA		
SCALE:	APPROVED BY:	DRAWN BY:
DATE:		REVISED:
		DRAWING NUMBER

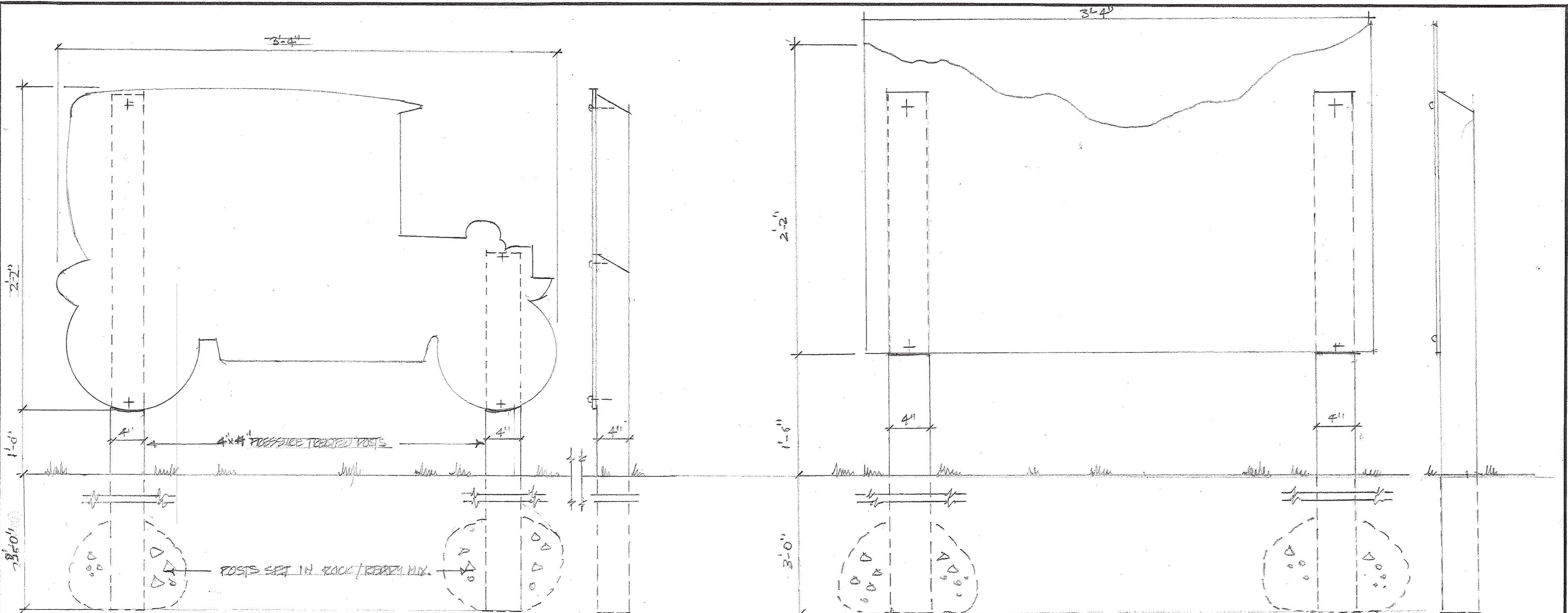

IP-1 - FRONT ELEVATION (A ROUND FIRE B.C. & PARK FOR CHAIRS)

SIDE ELEVATION

EP-2 - FRONT ELEVATION (A PARK DIVIDER)

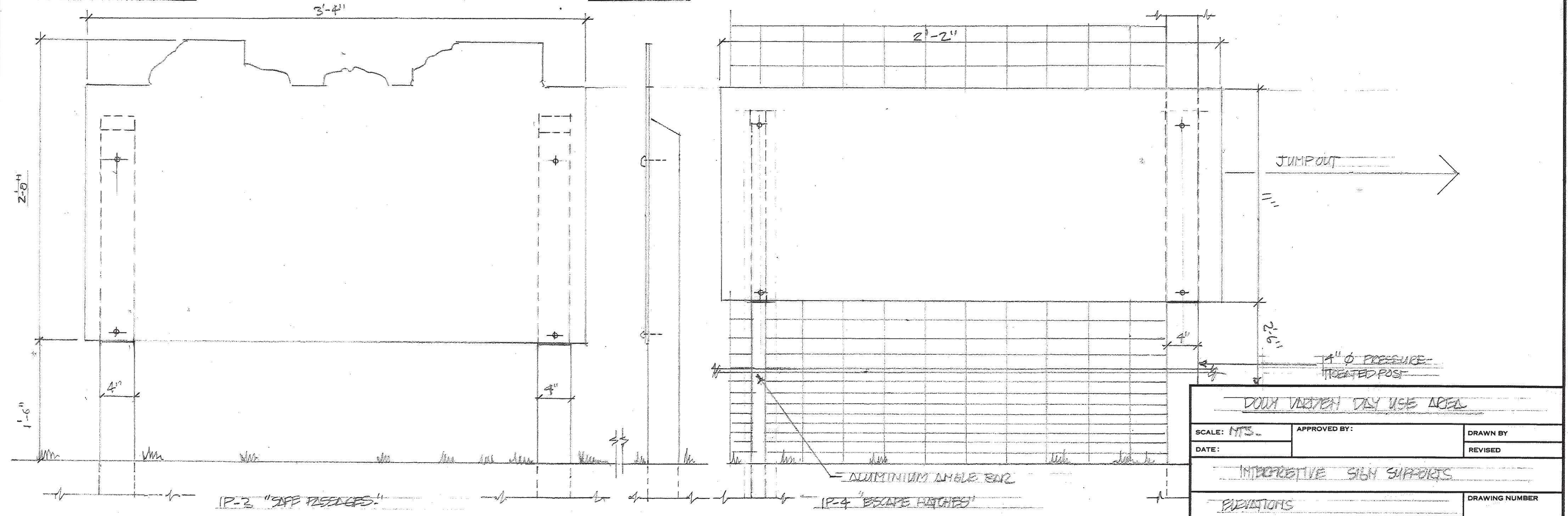

IP-2 "SAFE SEATINGS"

IP-4 "ESCAPE PATHS"

DOWN VERTICAL DRY USE AREA		
SCALE: NTS.	APPROVED BY:	DRAWN BY:
DATE:		REVISED:
INTERPRETIVE SIGN SUPPORTS		
ELEVATIONS		DRAWING NUMBER

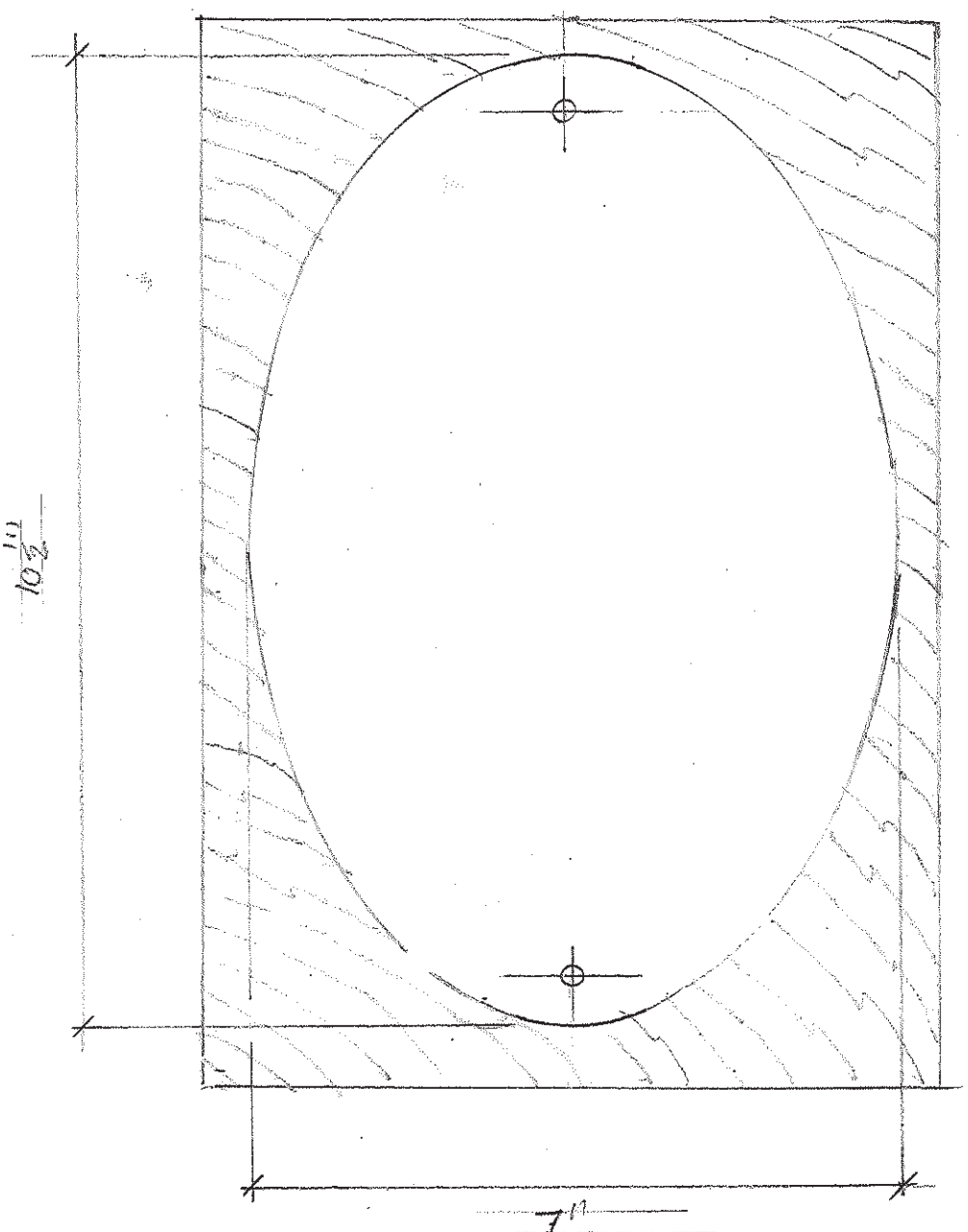
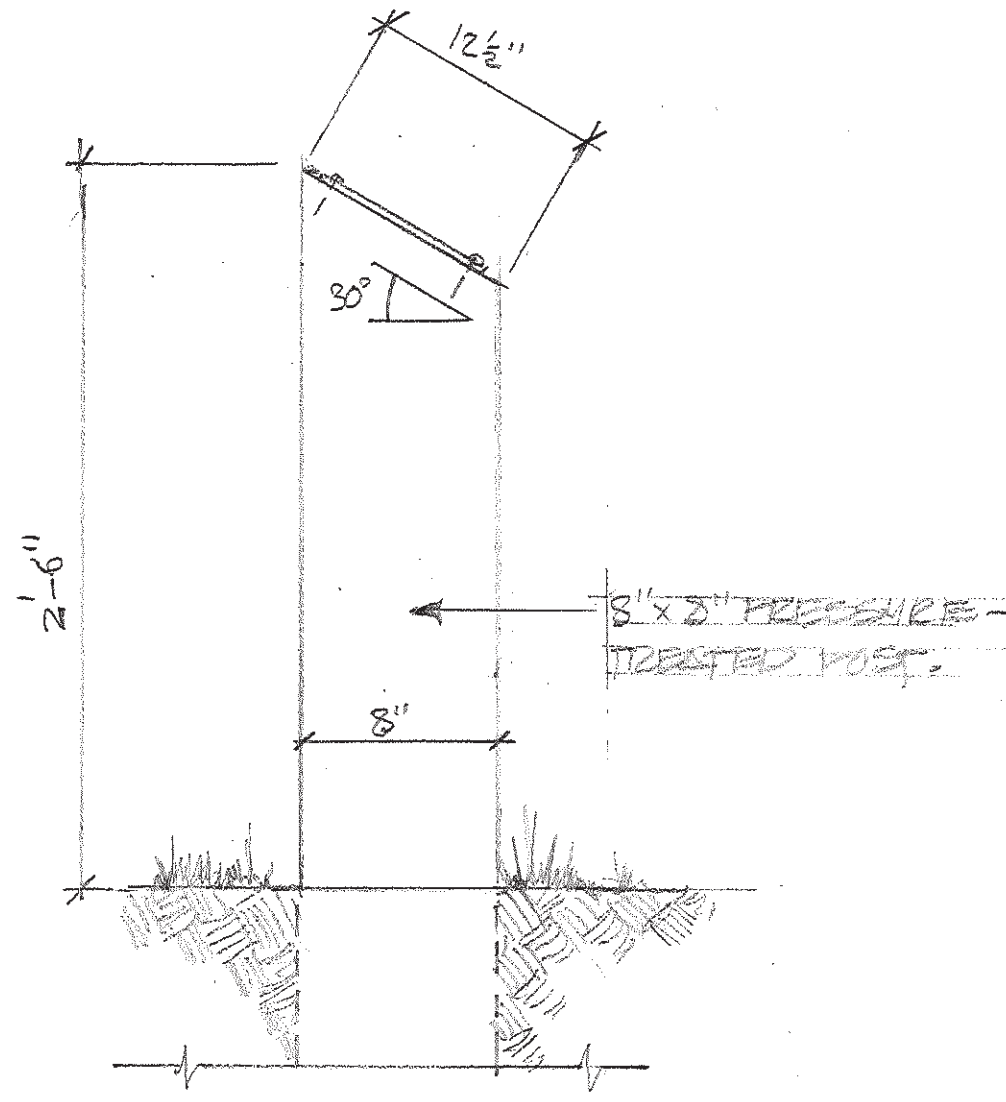

AT-1	BLACK BEAR
AT-2	WOLF
AT-3	DEER
AT-4	DOLLY VADDEN

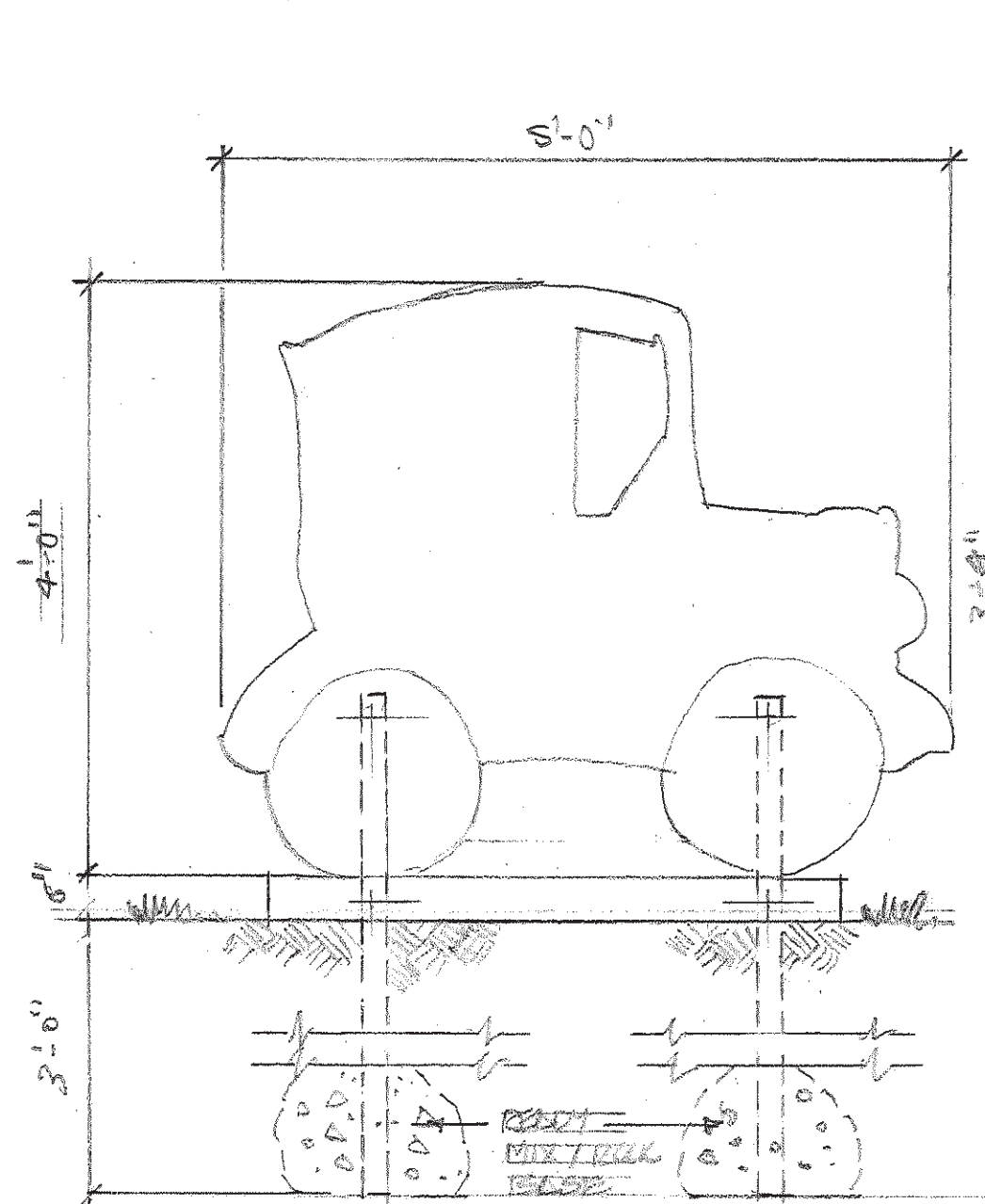

VC-2 "MODEL T FORD"
MOUNT ALUMINUM ANGLE BEG TO REVERSE OF PANEL WITH FIBER-GLASS BOLTS

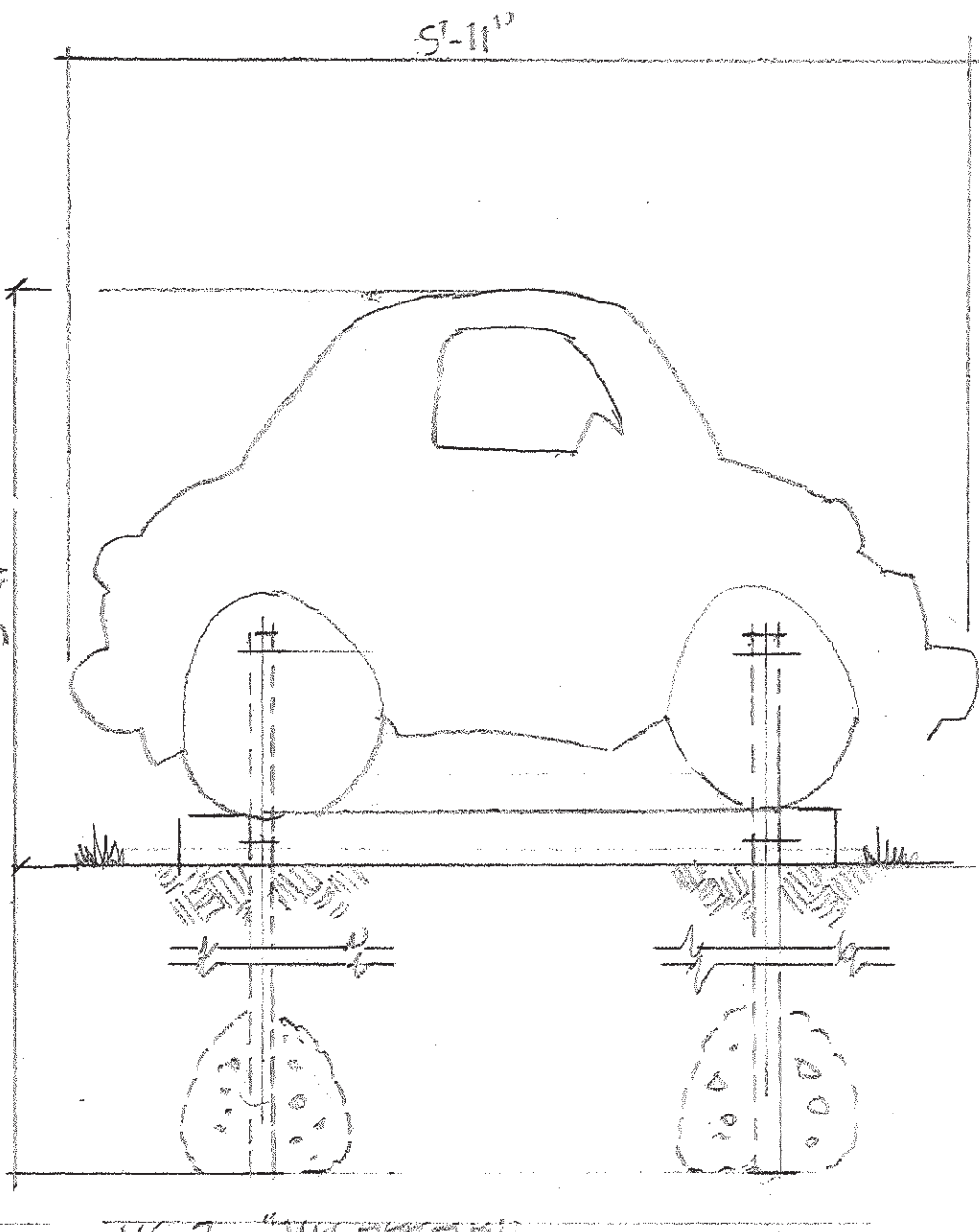

VC-3 "VW BEETLE"

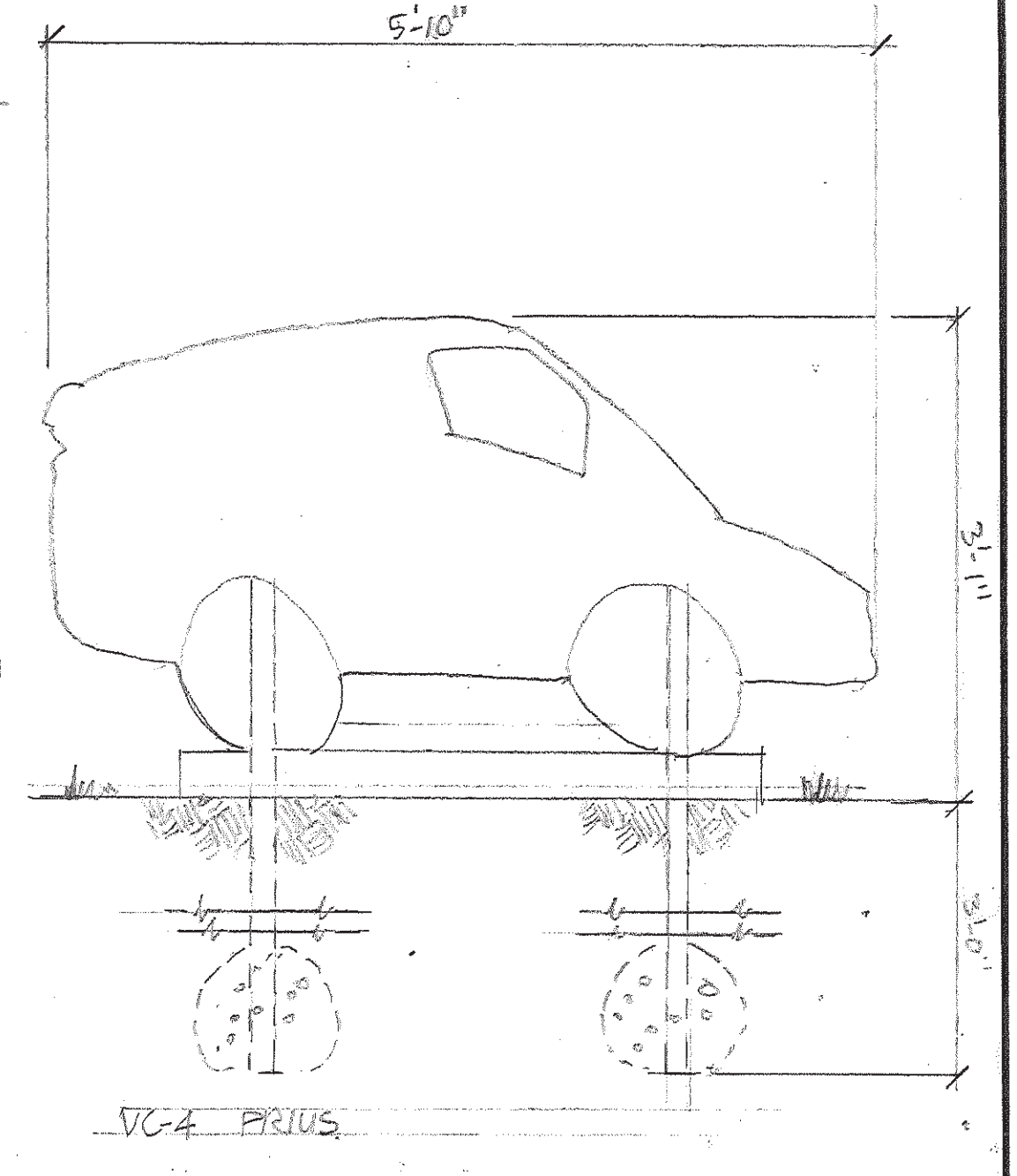

VC-4 PRIUS

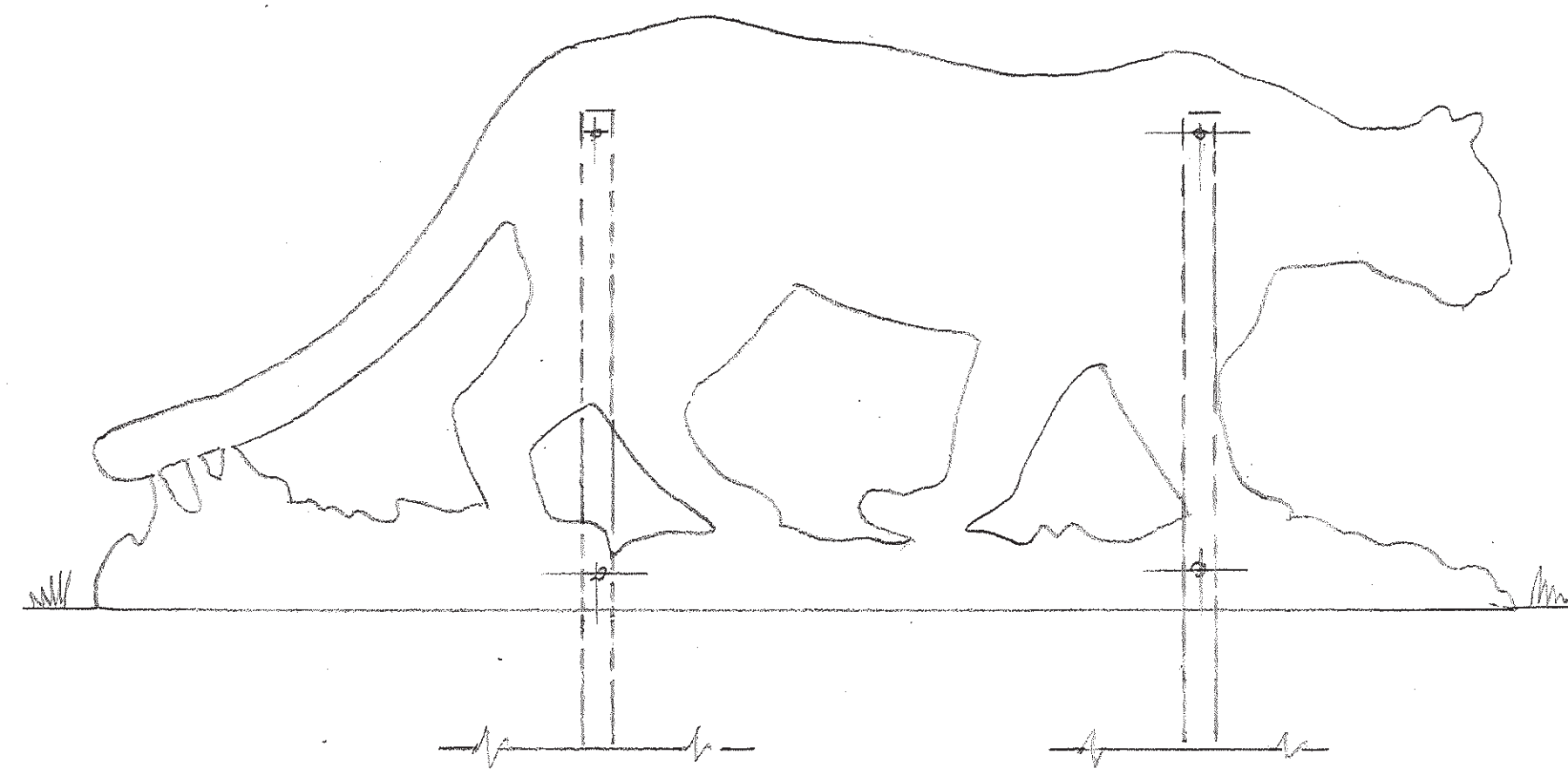

AC-3 "COUGAR"
LOCATED OUTSIDE WILDLIFE FENCE PLACING AWAY FROM MOUNT.
NOTE CIRCULAR INTERIOR PANEL TO BE LOCATED ON INSIDE OF THICKEST FENCE POST.

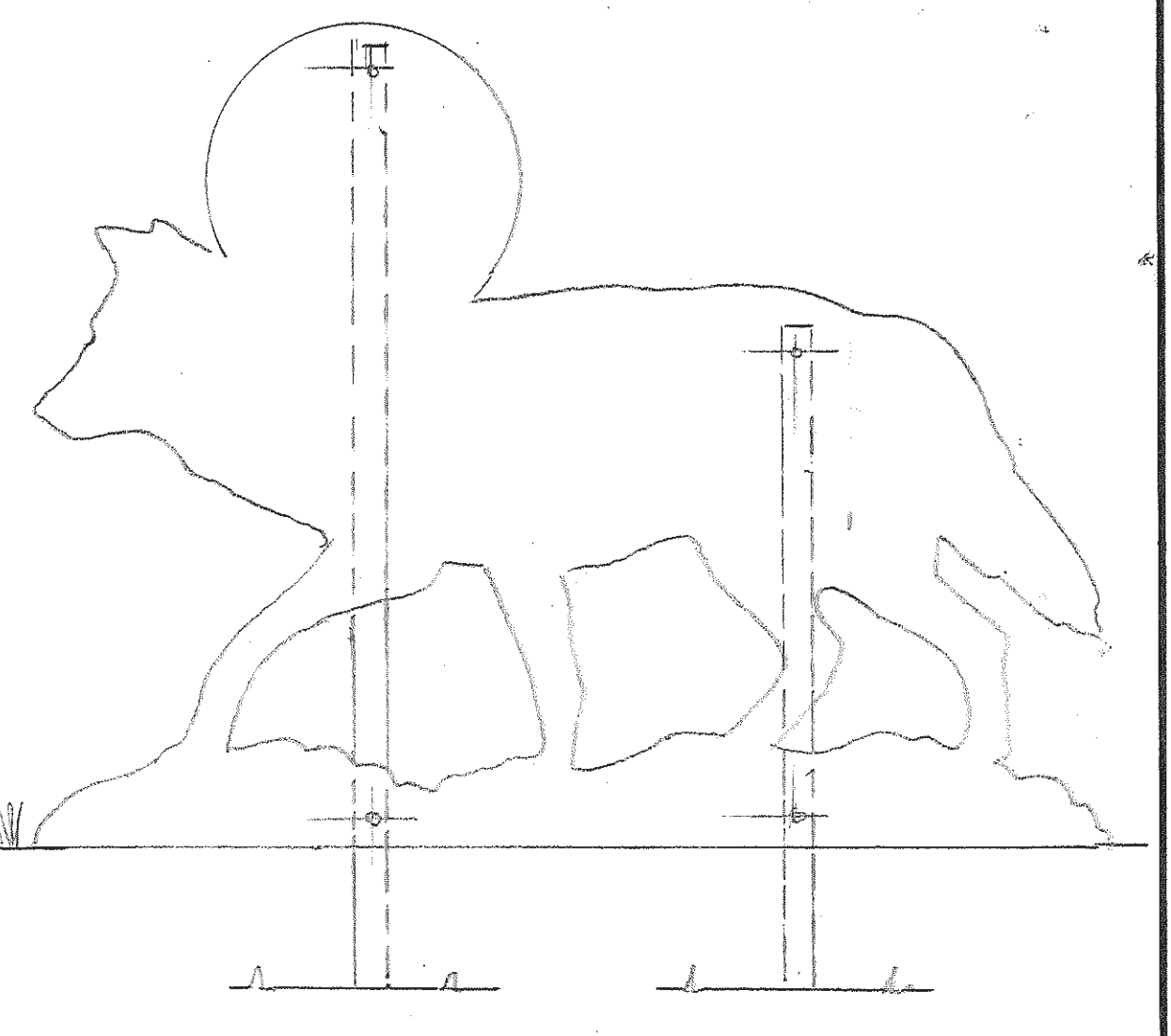

DOLLY VADDEN FISH USE AREA

SCALE:	APPROVED BY:	DRAWN BY:
DATE:		REVISED:
		DRAWING NUMBER:

Plot Date & Time: 2016-09-27, 2:57:22 PM

CORPLATE STRUCTURE
CORRUGATED STEEL ARCH
CP-A-11 SERIES
END AREA = 3.81 m²
20N TOTAL PERIPHERY
CORRUGATION PROFILE = 152 x 51

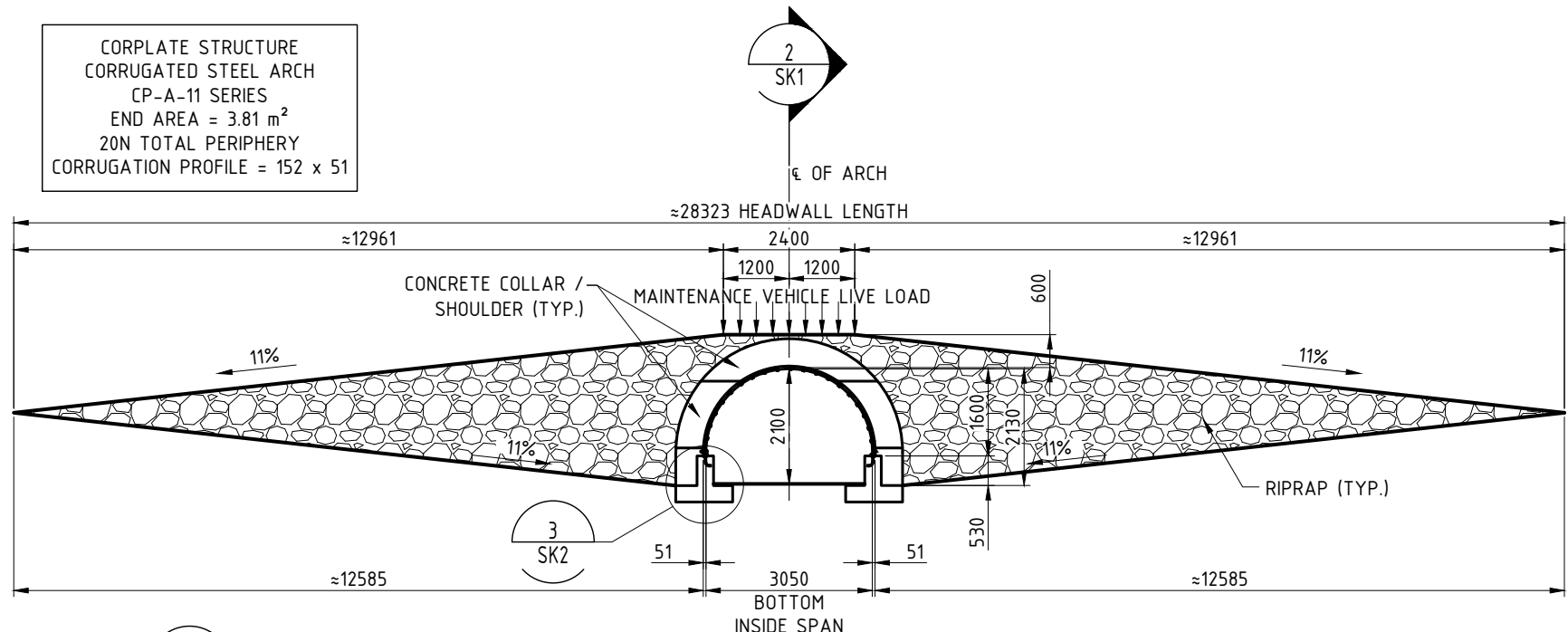

1 STRUCTURE GEOMETRY, ELEVATION
SK1 SCALE 1:125

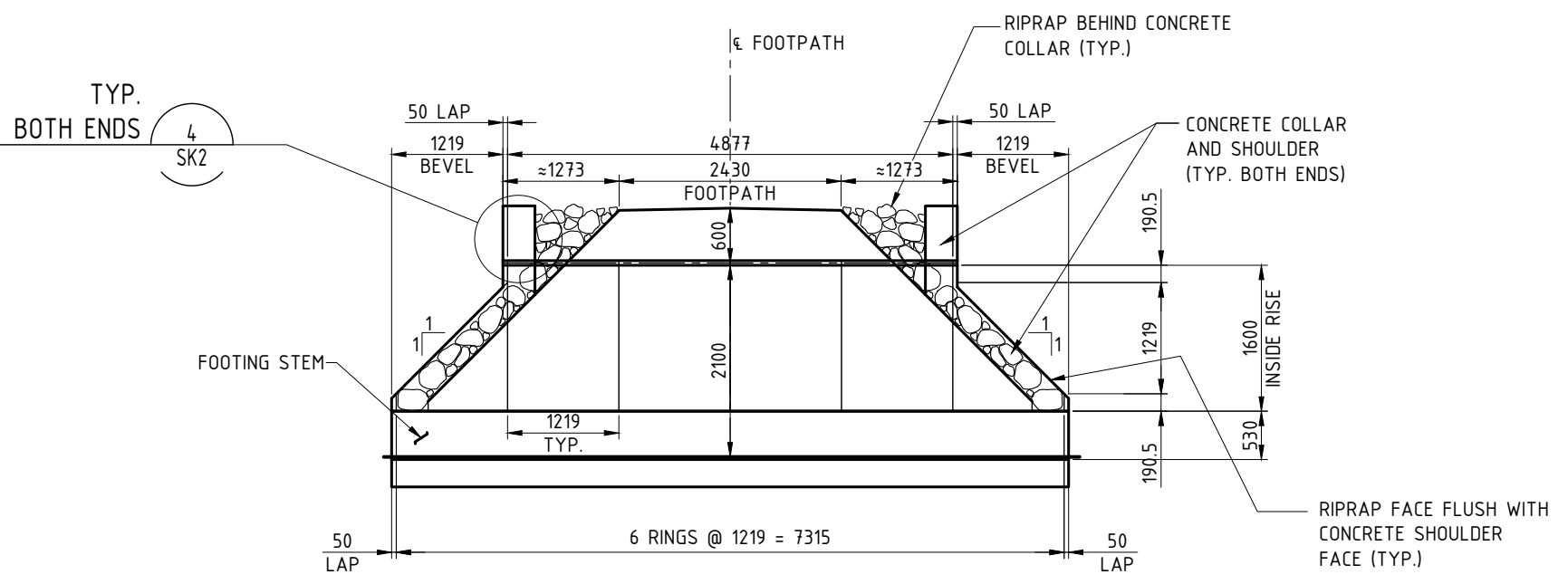

2 LONGITUDINAL PROFILE
SK1 SCALE 1:75

GENERAL DESIGN NOTES

1. GENERAL

- 1.1. SPSCP (STRUCTURAL PLATE CORRUGATED STEEL PIPE) CORPLATE.
- 1.2. CORRUGATION PROFILE = 152 x 51 mm.
- 1.3. ALL DIMENSIONS ARE IN MILLIMETERS (mm), UNLESS NOTED OTHERWISE.
- 1.4. ALL DIMENSIONS ARE TO THE INSIDE CREST OF STEEL, UNLESS NOTED OTHERWISE.
- 1.5. ALL DIMENSIONS ARE TO THE CENTRE OF BOLT HOLE.
- 1.6. 1N = 244 mm (ONE BOLT HOLE SPACE).
- 1.7. DIMENSIONS ARE SUBJECT TO MANUFACTURING TOLERANCES.

2. ENGINEERED BACKFILL

- 2.1. BURIED CORRUGATED STEEL PLATE STRUCTURE IS A COMPOSITE SYSTEM MADE UP OF THE STEEL RING AND THE ENGINEERED BACKFILL ENVELOPE, AND BOTH ELEMENTS PLAY A VITAL PART IN THE STRUCTURAL INTEGRITY THROUGHOUT THE SERVICE LIFE. THEREFORE IT IS IMPORTANT TO ENSURE THAT ENGINEERING BACKFILL IS MADE UP OF THE SPECIFIED MATERIAL AND WELL-CONSTRUCTED.
- 2.2. ENGINEERING BACKFILL MATERIAL SHALL BE CLEAN, GRANULAR, NON-FROST SUSCEPTIBLE, AND POSSESS TIME-INDEPENDENT PROPERTIES.
- 2.3. BACKFILL MATERIAL SHALL CONSIST OF A WELL GRADED GRANULAR MATERIAL WITH ANGULAR GRAINS CLASSIFYING AS "BRIDGE END FILL" IN SECTION 202 OF BC MOT STANDARD SPECIFICATIONS FOR HIGHWAY CONSTRUCTION AND MEETING THE FOLLOWING REQUIREMENTS.
- 2.4. MATERIAL GRADATION (ASTM C136 AND C117):

SIEVE NUMBER	SIEVE SIZE (mm)	PERCENT PASSING
	75.00	100
	50.00	30 - 100
	25.00	20 - 100
	19.00	15 - 95
4	4.75	10 - 65
16	1.18	6 - 35
50	0.30	4 - 20
200	0.075	0 - 10

- 2.5. PARTICLE ANGULARITY: PERCENTAGE OF FRACTURED GRAVEL PARTICLE (MINIMUM 2 FACES) SHALL BE MORE THAN 50 % (ASTM D5821).
- 2.6. PARTICLE DURABILITY OF THE COARSE AGGREGATE LOSS SHALL NOT EXCEED BY 30% AS DETERMINED BY MICRO-DEVAL TEST METHOD (ASTM D6928).
- 2.7. DELETERIOUS MATERIAL:
 - 2.7.1. BACKFILL MATERIAL SHALL BE FREE FROM FOREIGN MATTER.
 - 2.7.2. SHALES AND CLAYSTONES ARE GENERALLY CONSIDERED DELETERIOUS MATERIALS AND SHALL NOT BE ALLOWED IN THE ENGINEERED BACKFILL ENVELOPE.
 - 2.7.3. FROZEN MATERIAL SHALL NOT BE ALLOWED IN THE ENGINEERED BACKFILL ENVELOPE.
- 2.8. PLASTICITY INDEX: PLASTICITY INDEX (PI) OF FINE GRAINED PORTION OF THE SOIL SHALL BE LESS THAN 10 (ASTM D4318). PLASTICITY INDEX CAN BE WAIVED IF FINES CONTENT IS LESS THAN OR EQUAL TO 5%.
- 2.9. ELECTROCHEMICAL LIMITS FOR GALVANIZED PLATES (AASHTO CORROSION MODEL):

pH: 5 - 10	(AASHTO T289-91 OR EQUIVALENT)
RESISTIVITY: ≥ 3000 ohm-cm	(AASHTO T288-91 OR EQUIVALENT)
CHLORIDES: ≤ 100 ppm	(AASHTO T291-91 OR EQUIVALENT)
SULPHATES: ≤ 200 ppm	(AASHTO T290-91 OR EQUIVALENT)
ORGANIC CONTENT: ≤ 1%	(AASHTO T267-86 OR EQUIVALENT)
- 2.10. COMPACTION
 - 2.10.1. MAXIMUM UNCOMPACTED LIFT HEIGHT SHALL BE 200 mm.
 - 2.10.2. EACH LAYER SHALL BE COMPACTED TO MINIMUM OF 95% STANDARD PROCTOR DENSITY ASTM D 698.
 - 2.10.3. OPTIMUM MOISTURE CONTENT SHALL BE MAINTAINED DURING COMPACTION ASTM D 698.

PRELIMINARY
FOR INFORMATION ONLY

CANADACULVERT™		CUSTOMER PARKS CANADA				
CALL TOLL FREE 1-800-565-1152 www.canadaculvert.com		PROJECT NAME DOLLY VARDEN DAY PASS EXHIBIT, BC				
APPROVALS	DATE	DRAWING TITLE GEOMETRY - ELEVATION, LONGITUDINAL PROFILE				
DESIGN BY AR	2016-09-27					
DESIGN CHECK AR	2016-09-27					
DRAFT BY AT	2016-09-27					
DRAFT CHECK SM	2016-09-27					
PAPER SIZE 11x17	CONTRACT NO. -	SCALE AS NOTED	TOTAL SHEETS 1	PROJECT NO. 16-101	DRAWING NO. SK1	REV. 1

REV.NO	REVISION NOTE	DATE
1	REISSUED FOR INFORMATION	2016-09-27

z:\1_projects\2016\16-101 ab dolly varden day\drawings\in_progress\16-101_sk1-r1.dwg

Plot Date & Time: 2016-09-27, 2:57:23 PM

PRECAST CONCRETE FOOTING GENERAL NOTES

1. DESIGN IN GENERAL ACCORDANCE WITH CANADIAN HIGHWAY BRIDGE DESIGN CODE CAN/CSA-S6-14.
2. CONCRETE MATERIALS AND CONSTRUCTION PRACTICES TO CONFORM TO CSA23.4-09 - PRECAST CONCRETE - MATERIALS AND CONSTRUCTION.
3. ALL CONCRETE SHALL HAVE THE FOLLOWING PROPERTIES:
 - 3.1. MAXIMUM COURSE AGGREGATE SIZE OF 20 mm
 - 3.2. MINIMUM 28 DAYS COMPRESSIVE STRENGTH OF 35 MPa
 - 3.3. MINIMUM AIR ENTRAINMENT OF 5%
4. ALL REINFORCING STEEL SHALL CONFORM TO CAN/CSA G30.18 GRADE 400.
5. REINFORCING STEEL SHALL HAVE MINIMUM COVER OF 55 mm UNLESS NOTED OTHERWISE.
6. SLS SOIL BEARING CAPACITY OF 125 kPa WAS ASSUMED AND SHALL BE APPROVED BY OWNER'S ENGINEER.

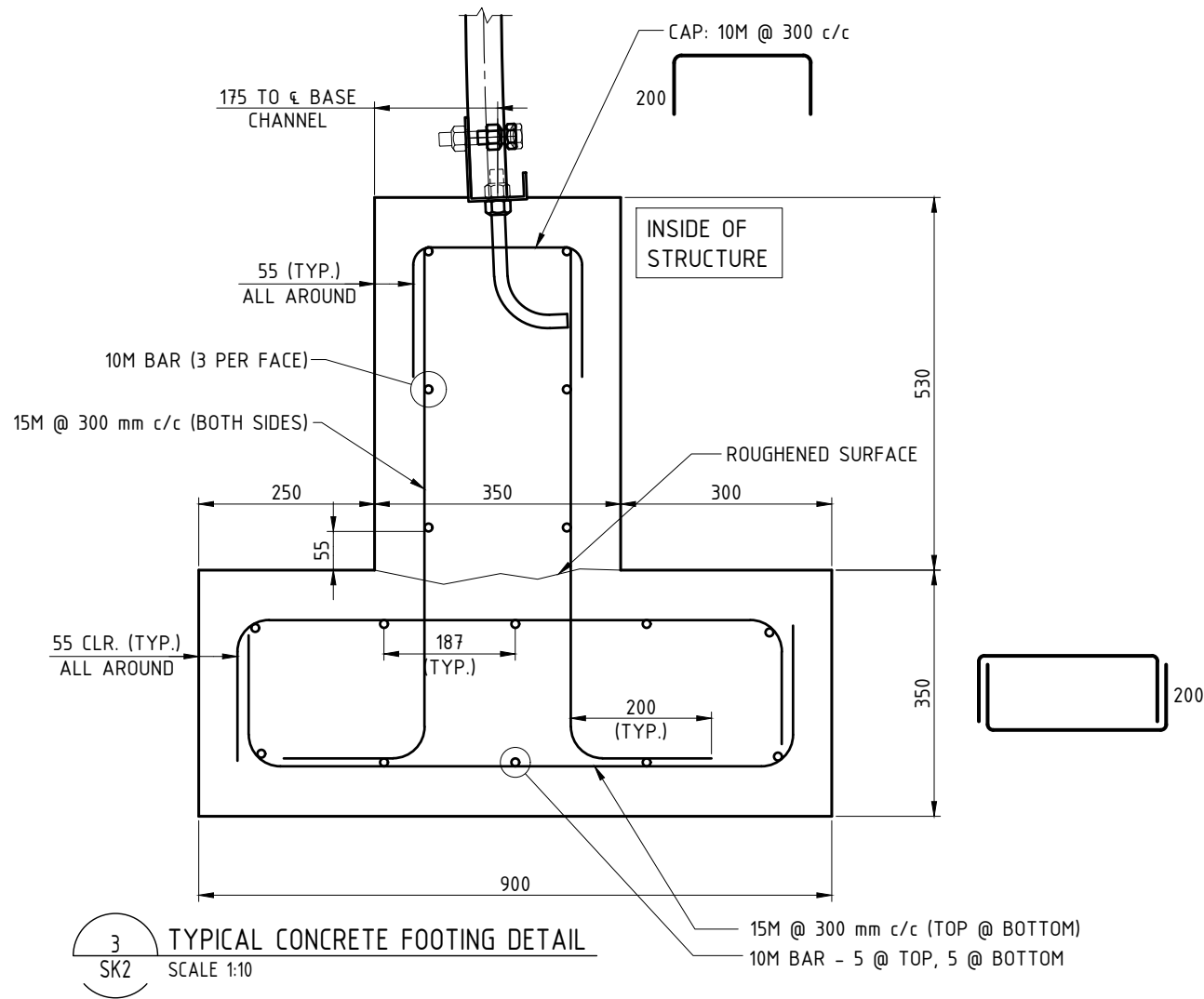

CAST-IN-PLACE CONCRETE COLLAR GENERAL NOTES

1. DESIGN IN GENERAL ACCORDANCE WITH CANADIAN HIGHWAY BRIDGE DESIGN CODE CAN/CSA-S6-14.
2. CONCRETE MATERIALS AND CONSTRUCTION PRACTICES TO CONFORM TO CSA 23.1-09 / CSA 23.2 - 09 CONCRETE MATERIALS AND METHODS OF CONCRETE CONSTRUCTION.
3. ALL CONCRETE SHALL HAVE THE FOLLOWING PROPERTIES:
 - 3.1. MAXIMUM COURSE AGGREGATE SIZE OF 20 mm
 - 3.2. MINIMUM 28 DAYS COMPRESSIVE STRENGTH OF 35 MPa.
 - 3.3. MINIMUM AIR ENTRAINMENT OF 5%.
4. ALL REINFORCING STEEL SHALL CONFORM TO CAN/CSA G30.18 GRADE 400.

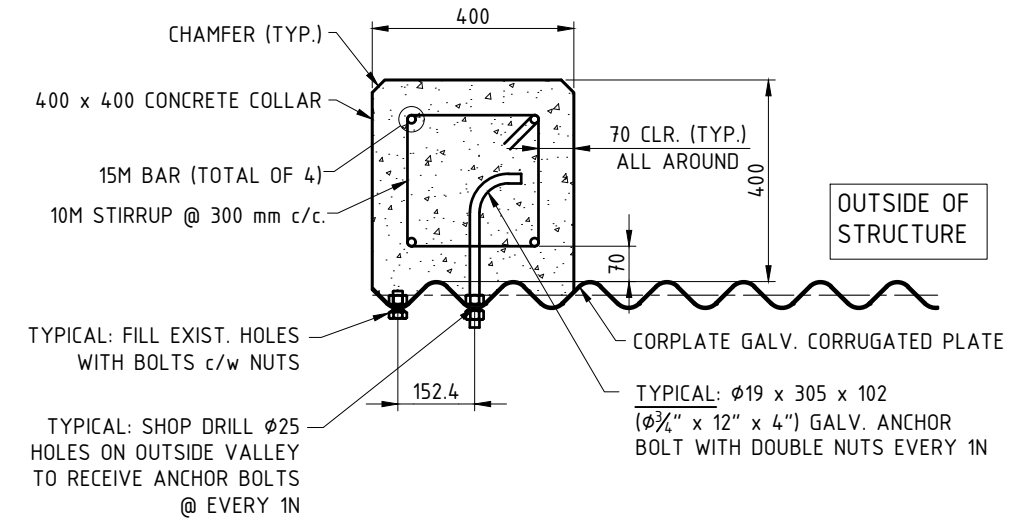

PRELIMINARY
FOR INFORMATION ONLY

		CUSTOMER PARKS CANADA		
		PROJECT NAME DOLLY VARDEN DAY PASS EXHIBIT, BC		
APPROVALS	DATE	DRAWING TITLE CONCRETE FOOTING AND COLLAR DETAILS, NOTES		
DESIGN BY	AR 2016-09-27			
DESIGN CHECK	AR 2016-09-27			
DRAFT BY	AT 2016-09-27			
DRAFT CHECK	SM 2016-09-27	PROJECT NO. 16-101		
PAPER SIZE 11x17	CONTRACT NO. -	SCALE AS NOTED	TOTAL SHEETS 1	DRAWING NO. SK2
		PROJECT NO. 16-101		REV. 0

REV.NO	REVISION NOTE	DATE
0	ISSUED FOR INFORMATION	2016-09-27

z:\1_projects\2016\16-101_ab_dolly_varden_day\drawings\in_progress\16-101_sk1-r1.dwg

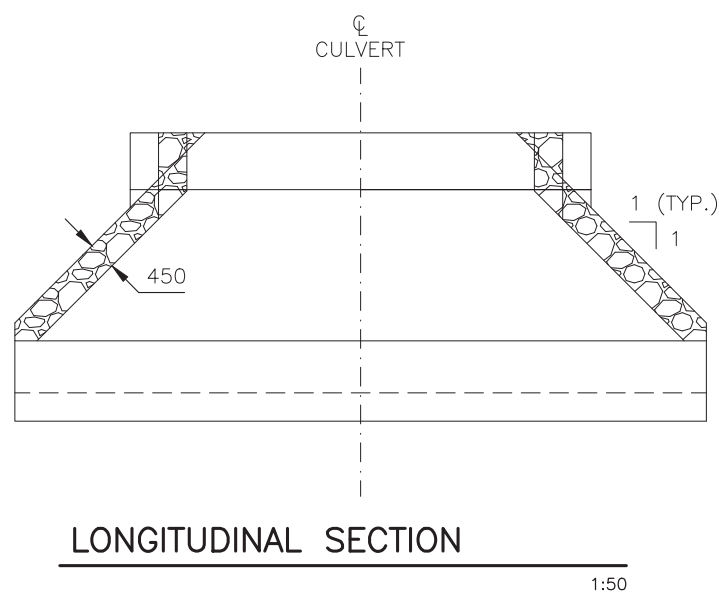
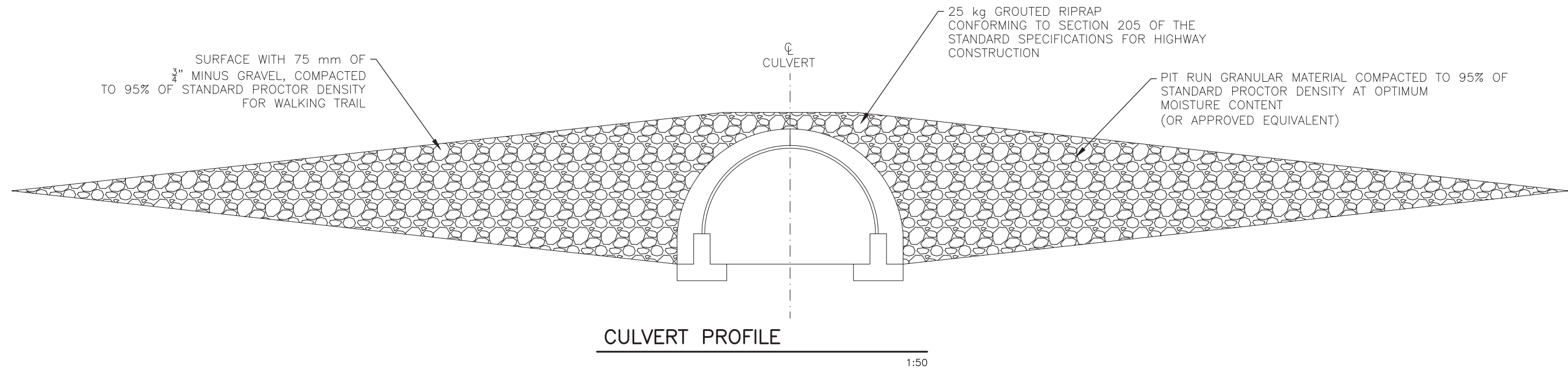

PIT RUN GRANULAR BACKFILL	m ³	140	
25 kg RIPRAP	m ³	45	
3/4" MINUS GRAVEL SURFACING	m ³	5	
ITEM	UNIT	ESTIMATE	AS CONST
QUANTITY ESTIMATE			

- NOTES**
- ALL WORK SHALL CONFORM TO THE 2012 STANDARD SPECIFICATIONS FOR HIGHWAY CONSTRUCTION ISSUED BY THE BRITISH COLUMBIA MINISTRY OF TRANSPORTATION AND INFRASTRUCTURE

CONSULTANT  JOB No. 1082		△ △ △ △ △							PARKS CANADA WILDLIFE UNDERPASS DOLLY VARDEN DAY USE AREA GENERAL LAYOUT		
		REV	DATE	REVISION	LOCATION	SITE	BY	CONTRACT	HIGHWAY	SHEET 5 OF 5	DRAWING RE1082-1
			2016-09-23								