



SPECIFICATIONS

SOLICITATION #: 16-22096

BUILDING: M-50
1200 Montreal Road
Ottawa, Ontario

PROJECT: M50- New Oxygen Generation System

PROJECT #: 5200

Date: October 2016



SPECIFICATION

TABLE OF CONTENTS

Construction Tender Form

Buyandsell Notice

Instructions to Bidders

Ontario Sales Tax

Acceptable Bonding Companies

Articles of Agreement

Plans and Specifications **A**

Terms of Payment **B**

General Conditions **C**

Labour Conditions and Fair Wage Schedule **D**

N/A

Insurance Conditions **E**

Contract Security Conditions **F**

Security Requirement Check List **G**

Directions to the Ottawa Research Facilities – Montreal Road

1200 Montréal Road
Ottawa, Ontario, Canada K1A 0R6

Tel: 613-993-9101

NRC Institutes/Branch/Program	Buildings
Information/Security	M-1
NRC Administrative Services and Property Management (NRC-ASPM)	M-5, M-6, M-15, M-16, M-18A, M-19, M-22, M-26, M-39, M-40A, M-53
NRC Canada Institute for Scientific and Technical Information (NRC-CISTI)	M-50, M-55
NRC Canadian Hydraulics Centre (NRC-CHC)	M-32
NRC Communications and Corporate Relations Branch (NRC-CCRB)	M-58
NRC Design and Fabrication Services (DFS)	M-2, M-4, M-10, M-36
NRC Financial Branch (NRC-FB)	M-58
NRC Human Resources Branch (NRC-HRB)	M-55, M-58
NRC Industrial Research Assistance Program (NRC-IRAP)	M-55
NRC Industry Partnership Facility (NRC-IPF)	M-50
NRC Information Management Services Branch (NRC-IMSB)	M-60
NRC Institute For Aerospace Research (NRC-IAR)	M-2, M-3, M-7, M-10, M-11, M-13, M-14, M-17, M-41, M-42, M-43, M-44, M-46, M-47
NRC Institute For Biological Science (NRC-IBS)	M-54
NRC Institute For Chemical Process and Environmental Technology (NRC-ICPET)	M-8, M-9, M-10, M-12, M-45
NRC Institute For Information Technology (NRC-IIT)	M-2, M-50
NRC Institute For Microstructural Sciences (NRC-IMS)	M-36, M-37, M-50
NRC Institute For National Measurements Standards (NRC-INMS)	M-35, M-36, M-51
NRC Institute For Research In Construction (NRC-IRC)	M-20, M-24, M-25, M-27, M-42, M-48, M-59
NRC Strategy and Development Branch (NRC-SDB)	M-58

By Road, from the OTTAWA International Airport

1. From the airport take the AIRPORT PARKWAY to RIVERSIDE DR EAST
2. Follow RIVERSIDE DR EAST to HIGHWAY 417 EAST
3. Take HIGHWAY 417 EAST, past the ST-LAURENT BLVD exit, where HIGHWAY 417 splits, continue LEFT on HIGHWAY 174 (ROCKLAND)
4. Exit HIGHWAY 174 on BLAIR RD NORTH
5. Proceed on BLAIR RD NORTH, cross OGILVIE RD, and continue on to the traffic lights at the intersection of BLAIR and MONTREAL RD
6. Turn left onto MONTREAL RD and take the first immediate right onto the ramp leading down to the traffic circle. Stop at Building M-1 on the north side of the traffic circle. Ask the commissionaires in M-1 for directions to the NRC building, institute or staff member you seek.

By Road, from MONTRÉAL

1. Take MÉTROPOLITAIN 40 WEST and follow signs for OTTAWA and HIGHWAY 417 WEST
2. Follow 417 WEST to reach OTTAWA
3. Exit at HIGHWAY 174 EAST (ROCKLAND) when entering OTTAWA
4. Follow 174 EAST and exit at BLAIR RD NORTH (first exit after entering 174 EAST)
5. Follow BLAIR RD NORTH, cross OGILVIE RD, and continue on to the traffic lights at the intersection of BLAIR and MONTREAL RD
6. Turn left onto MONTREAL RD and take the first immediate right onto the ramp leading down to the traffic circle. Stop at Building M-1 on the north side of the traffic circle. Ask the commissionaires in M-1 for directions to the NRC building, institute or staff member you seek.



- | | | | | |
|--|---|---|---|---|
|  NRC Institute |  Major HWY |  Airport |  Ferry |  Metro |
|  Trans Canada HWY |  Secondary HWY |  Train Station |  Bus Station | |



National Research Council Canada
 Conseil national de recherches Canada

MONTREAL ROAD CAMPUS INSTITUTES AND LABORATORIES OTTAWA, CANADA

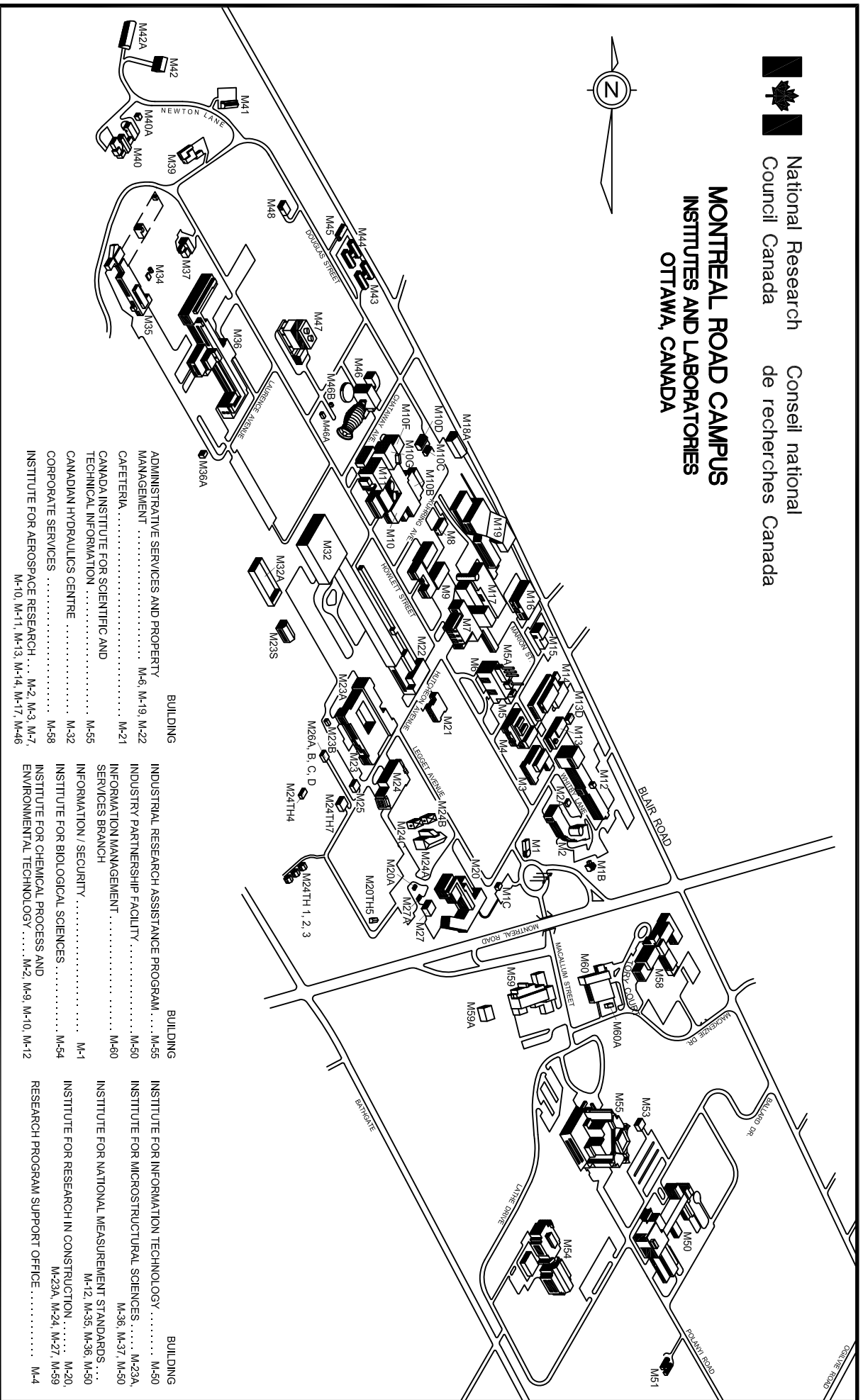
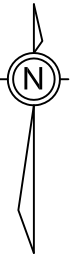

- | | | | | |
|--|----------|--|----------|--|
| ADMINISTRATIVE SERVICES AND PROPERTY MANAGEMENT M-6, M-19, M-22 | BUILDING | INDUSTRIAL RESEARCH ASSISTANCE PROGRAM M-55 | BUILDING | INSTITUTE FOR INFORMATION TECHNOLOGY M-50 |
| CAFETERIA M-21 | | INDUSTRY PARTNERSHIP FACILITY M-50 | | INSTITUTE FOR MICROSTRUCTURAL SCIENCES M-23A, M-36, M-37, M-50 |
| CANADA INSTITUTE FOR SCIENTIFIC AND TECHNICAL INFORMATION M-55 | | SERVICES BRANCH | | INSTITUTE FOR NATIONAL MEASUREMENT STANDARDS M-12, M-35, M-36, M-50 |
| CANADIAN HYDRAULICS CENTRE M-32 | | INFORMATION / SECURITY M-1 | | INSTITUTE FOR RESEARCH IN CONSTRUCTION M-20, M-23A, M-24, M-27, M-59 |
| CORPORATE SERVICES M-58 | | INSTITUTE FOR BIOLOGICAL SCIENCES M-54 | | RESEARCH PROGRAM SUPPORT OFFICE M-4 |
| INSTITUTE FOR AEROSPACE RESEARCH M-2, M-3, M-7, M-10, M-11, M-13, M-14, M-17, M-46 | | INSTITUTE FOR CHEMICAL PROCESS AND ENVIRONMENTAL TECHNOLOGY M-2, M-9, M-10, M-12 | | |

National Research Council Conseil national de recherches
Canada Canada

Administrative Services Direction des services
& Property management administratif et gestion
Branch (ASPM) de l'immobilier (SAGI)

Construction Tender Form

Project Identification **M50- New Oxygen Generation System**

Tender No.: **16-22096**

1.2 Business Name and Address of Tenderer

Name _____

Address _____

Contact Person(Print Name) _____

Telephone (_____) _____ **Fax:** (_____) _____

1.3 Offer

I/We the Tenderer, hereby offer to Her Majesty the Queen in Right of Canada (hereinafter referred to as "Her Majesty") represented by the National Research Council Canada to perform and complete the work for the above named project in accordance with the Plans and Specifications and other Tender Documents, at the place and in the manner set out therein for the Total Tender Amount (to be expressed in numbers only) of: \$_____. _____ **in lawful money of Canada (excluding GST/HST)**

The above amount is inclusive of all applicable (*) Federal, Provincial and Municipal taxes except that in the event of a change in any tax imposed under the Excise Act, the Excise Tax Act, the Old Age Security Act, the Customs Act, the Customs Tariff or any provincial sales tax legislation imposing a retail sales tax on the purchase of tangible personal property incorporated into Real Property, that occurs

- .1 after the date this tender was mailed or delivered, or
- .2 if this tender is revised, after the date of the last revision

the amount of this offer shall be decreased or decreased in the manner provided for in GC22 of the General Conditions of the Contract Documents.

National Research Council Canada	Conseil national de recherches Canada
Administrative Services & Property management Branch (ASPM)	Direction des services administratif et gestion de l'immobilier (SAGI)

1.3.1 Offer (continued)

(*) For the purpose of this tender, the Goods and Services Tax (GST) is not to be considered as an applicable tax.

In the province of Quebec, the Quebec Sales Tax is not to be included in the tender amount because the Federal Government is exempt from this tax. Tenderers shall make arrangements directly with the provincial Revenue Department to recover any tax they may pay on good and servives acquired in the performance of this contract. However, tenderers should include in their tender amount Quebec Sales Tax for which an Input Tax Refund is not available.

1.4 Acceptance and Entry into Contract

I/We undertake, within fourteen (14) days of notification of acceptance of my/our offer, to sign a contract for the performance of the work provided I/we are notified, by the Department, of the acceptance of my/our offer within 30 days of the tender closing date.

1.5 Construction Time

I/We Agree to complete the work within the time stipulated in the specification from the date of notification of acceptance of my/our offer.

1.6 Bid Security

I/We herewith enclose tender security in accordance with Article 5 of the General Instruction to Tenderers.

I/We understand that if a security deposit is furnished as tender security and if I/we refuse to enter into a contract when called upon to do so, my/our security deposit shall be forfeited but the Minister may, if it is in the public interest, waive the right of Her Majesty to forfeit the security deposit.

I/We understand that if the security furnished is not in the approved form as described in Article 5 of the General Instructions to Tenderers, my/our tender is subject to disqualification.

National Research Council Conseil national de recherches
Canada Canada

Administrative Services Direction des services
& Property management administratif et gestion
Branch (ASPM) de l'immobilier (SAGI)

1.7 Contract Security

Within fourteen (14) days after receipt of written notification of the acceptance of my/our offer, I/we will furnish contract security in accordance with the Contract Conditions "F" of the Contract Documents.

I/We understand that the contract security referred to herein, if provided in the form of a bill of exchange, will be deposited into the Consolidated Revenue Fund of Canada.

1.8 Appendices

This Tender Form includes Appendix No. ____N/A_____.

1.9 Addenda

The Total Tender Amount provides for the Work described in the following Addenda:

NUMBER	DATE	NUMBER	DATE

(Tenderers shall enter numbers and dates of addenda)

National Research Council Canada	Conseil national de recherches Canada
-------------------------------------	--

Administrative Services & Property management Branch (ASPM)	Direction des services administratif et gestion de l'immobilier (SAGI)
---	--

1.10 Execution of Tender

The Tenderer shall refer to Article 2 of the General Instructions to Tenderers.

**SIGNED, ATTESTED TO AND DELIVERED on the _____ day of
_____ on behalf of**

(Type or print the business name of the Tenderer)

AUTHORIZED SIGNATORY (IES)

(Signature of Signatory)

(Print name & Title of Signatory)

(Signature of Signatory)

(Print name & Title of Signatory)

SEAL

BUY AND SELL NOTICE

M50- New Oxygen Generation System

The National Research Council Canada, 1200 Montreal Road Ottawa, ON has a requirement for a project that includes:

The work is to construct a new oxygen generation system in building M50. Contractor shall provide a new compressed air system, oxygen generator, electrical system, and room ventilation system as per the drawings and specifications.

1. GENERAL

Questions regarding any aspect of the project are to be addressed to and answered only by the Departmental Representative (or his designate) or the Contracting Authority.

Any information received other than from the Departmental Representative (or his designate) or the Contracting Authority will be disregarded when awarding the contract and during construction.

Firms intending to submit tenders on this project should obtain tender documents through the Buyandsell.gc.ca TMA services provider. Addenda, when issued, will be available from the Buyandsell.gc.ca TMA service provider. Firms that elect to base their bids on tender documents obtained from other sources do so at their own risk and will be solely responsible to inform the tender calling authority of their intention to bid. Tender packages are not available for distribution on the actual day of tender closing.

2. MANDATORY SITE VISIT

It is mandatory that the bidder attends one of the site visits at the designated date and time. At least one representative from proponents that intend to bid must attend.

The site visits will be held on November 7th and November 9th, 2016 at **9:00**. Meet Allan Smith at Building M-50, Main Entrance, 1200 Montreal Road Ottawa, ON. Bidders who, for any reason, cannot attend at the specified date and time will not be given an alternative appointment to view the site and their tenders, therefore, will be considered as non-responsive. **NO EXCEPTIONS WILL BE MADE.**

As proof of attendance, at the site visit, the Contracting Authority will have an Attendance Form which **MUST** be signed by the bidder's representative. It is the responsibility of all bidders to ensure they have signed the Mandatory Site Visit Attendance form prior to leaving the site. Proposals submitted by bidders who have not attended the site visit or failed to sign the Attendance Form will be deemed non-responsive.

3. CLOSING DATE

Closing date is November 29th, 2016 at 14:00.

4. TENDER RESULTS

Following the Tender closing, the tender results will be sent by facsimile to all Contractors who submitted a tender

5. SECURITY REQUIREMENT FOR CANADIAN CONTRACTORS

5.1 MANDATORY SECURITY REQUIREMENT:

This procurement contains a mandatory security requirement as follows:

- 1 The Contractor must, at all times during the performance of the Contract, hold a valid Designated Organization Screening (DOS), issued by the Canadian Industrial Security Director (CISD), Public Works Government Services Canada.
- 2 The Contractor personnel requiring access to sensitive work site(s) must EACH hold a valid RELIABILITY STATUS, granted or approved by CISD/PWGSC.
- 3 The Contractor must comply with the provisions of the:
 - a. Security Requirements Checklist attached at Appendix "D"
 - b. Industrial Security Manual (Latest Edition) available at: <http://ssi-iss.tpsgc-pwgsc.gc.ca/ssi-iss-services/eso-oss-eng.html>

5.2 VERIFICATION OF SECURITY CLEARANCE AT BID CLOSING

- 1 The Bidder must hold a valid Designated Organization Screening (DOS) issued by the Canadian Industrial Security Directorate (CISD), Public Works and Government Services Canada (PWGSC), **TO BE INCLUDED WITH THEIR TENDER OR PROVIDED WITHIN 48 HOURS FROM THE DATE AND TIME OF TENDER CLOSING.** Verifications will be made through CISD to confirm the security clearance status of the Bidder. Failure to comply with this requirement will render the bid non-compliant and no further consideration will be given to the bid.
- 2 Within 72 hours of tender closing, the General Contractor must name all of his sub-contractors, each of whom **must hold a valid RELIABILITY STATUS**, granted or approved by CISD/PWGSC, or any other Federal Department or Agency along with the names and birthdates or security clearance certificate numbers of all personnel who will be assigned to the project.
- 3 It is to be noted that any subcontractor required to perform any part of the work during the performance of the subsequent contract must also adhere to the mandatory security requirement of the contract. As well, no personnel without the required level of security will be allowed on site. It will be the responsibility of the successful bidder to ensure that the security requirement is met throughout the performance of the contract. The Crown will not be held liable or accountable for any delays or additional costs associated with the contractor's non-compliance to the mandatory security requirement. Failure to comply with the mandatory security requirement will be grounds for being declared in default of contract.
- 4 For any enquiries concerning the project security requirement during the bidding period, the Bidder/Tenderer must contact the Security Officer @ 613-993-8956.

6.0 WSIB (WORKPLACE SAFETY AND INSURANCE BOARD)

- 1 All Bidders must provide a valid WSIB certificate with their Tender or prior to contract award.

7.0 OFFICE OF THE PROCUREMENT OMBUDSMAN

1 Dispute Resolution Services

The parties understand that the Procurement Ombudsman appointed pursuant to Subsection 22.1(1) of the *Department of Public Works and Government Services Act* will, on request or consent of the parties to participate in an alternative dispute resolution process to resolve any dispute between the parties respecting the interpretation or application of a term and condition of this contract and their consent to bear the cost of such process, provide to the parties a proposal for an alternative dispute resolution process to resolve their dispute. The Office of the Procurement Ombudsman may be contacted by telephone at 1-866-734-5169 or by e-mail at boa.opo@boa-opo.gc.ca.

2 Contract Administration

The parties understand that the Procurement Ombudsman appointed pursuant to Subsection 22.1(1) of the *Department of Public Works and Government Services Act* will review a complaint filed by [*the supplier or the contractor or the name of the entity awarded this contract*] respecting administration of this contract if the requirements of Subsection 22.2(1) of the *Department of Public Works and Government Services Act* and Sections 15 and 16 of the *Procurement Ombudsman Regulations* have been met, and the interpretation and application of the terms and conditions and the scope of the work of this contract are not in dispute. The Office of the Procurement Ombudsman may be contacted by telephone at 1-866-734-5169 or by e-mail at boa.opo@boa-opo.gc.ca.

- 3 The Office of the Procurement Ombudsman (OPO) was established by the Government of Canada to provide an independent avenue for suppliers to raise complaints regarding the award of contracts under \$25,000 for goods and under \$100,000 for services. You have the option of raising issues or concerns regarding the solicitation, or the award resulting from it, with the OPO by contacting them by telephone at 1-866-734-5169 or by e-mail at boa.opo@boa-opo.gc.ca. You can also obtain more information on the OPO services available to you at their website at www.opo-boa.gc.ca.

The Departmental Representative or his designate for this project is: **Allan Smith**
Telephone: **613 993-4926**.

Contracting Authority for this project is: **Alain Leroux** alain.leroux@nrc-cnrc.gc.ca
Telephone: **613 991-9980**.

INSTRUCTIONS TO BIDDERS

Article 1 – Receipt of Tender

- 1a) Tenders must be received not later than the specified tender closing time. Tenders received after this time are invalid and shall not be considered, regardless of any reason for their late arrival.
- 1b) A letter of printed telecommunication from a bidder quoting a price shall not be considered as a valid tender unless a formal tender has been received on the prescribed Tender Form.
- 1c) Bidders may amend their tenders by letter or printed telecommunication provided that such amendments are received not later than the specified tender closing time.
- 1d) Any amendments to the tender which are transmitted by telefax must be signed and must clearly identify the tenderer.

All such amendments are to be addressed to:
National Research Council of Canada
Alain Leroux, Senior Contracting Officer
Building M-22
Montreal Road, Ottawa, Ontario
K1A 0R6

Fax: (613) 991-3297

Article 2 – Tender Form & Qualifications

- 1) All tenders must be submitted on the Construction Tender Form and the tender must be signed in compliance with the following requirements:
 - a) Limited Company: The full names of the Company and the name(s) and status of the authorized signing officer(s) must be printed in the space provided for that purpose. The signature(s) of the authorized officer(s) and the corporate seal must be affixed.
 - b) Partnership: The firm name and the name(s) of the person(s) signing must be printed in the space provided. One or more of the partners must sign in the presence of a witness who must also sign. An adhesive coloured seal must be affixed beside each signature.
 - c) Sole Proprietorship : The business name and the name of the sole proprietor must be printed in the space provided. The sole proprietor must sign in the presence of a witness who must also sign. An adhesive coloured seal must be affixed beside each signature.
- 2) Any alterations in the printed part of the Construction Tender Form or failure to provide the information requested therein, may render the tender invalid.
- 3) All space in the Construction Tender Form must be completed and any handwritten or typewritten corrections to the parts so completed must be initialed immediately to the side of the corrections by the person or persons executing the tender on behalf of the the tenderer.
- 4) Tenders must be based on the plans, specifications and tender documents provided.

Article 3 - Contract

- 1) The Contractor will be required to sign a contract similar to the Standard Contract Form for Fixed Price Construction Contracts, a blank specimen of which is enclosed in the package for reference purposes.

Article 4 – Tender Destination

- 1a) Tenders are to be submitted in sealed envelopes to:
National Research Council Canada
Administrative Services and Property Management Branch
1200 Montreal Road
Building M-22
Ottawa, ON
K1A 0R6

Endorsed "Tender for (insert title of work as it appears in the drawings and specifications)" and must bear the name and address of the tenderer.

- 1b) Unless otherwise specified, the only documents required to be submitted with the tender are the Tender form and the Bid Security.

Article 5 - Security

- 1a) Bid Security is required and must be submitted in one of the following forms:
 - i) a certified cheque payable to the Receiver General for Canada and drawn on a member of the Canadian Payments Association or a local cooperative credit society that is a member of a central cooperative credit society having membership in the Canadian Payments Association; **OR**
 - ii) bonds of the Government of Canada, or bonds unconditionally guaranteed as to principal and interest by the Government of Canada; **OR**
 - iii) a bid bond.
- 1b) Regardless of the Bid Security submitted, it should never be more than \$250,000 maximum, calculated at 10% of the first \$250,000 of the tendered price, plus 5% of any amount in excess of \$250,000.
- 2a) Bid Security shall accompany each tender or, if forwarded separately from the tender, shall be provided not later than the specified tender closing time. Bid Security must be in the **ORIGINAL** form. Fax or photocopies and **NOT** acceptable. **FAILURE TO PROVIDE THE REQUIRED BID SECURITY SHALL INVALIDATE THE TENDER.**
- 2b) If the tender is not accepted, the Bid Security submitted pursuant to Article 8 shall be returned to the tenderer.
- 3a) The successful tenderer is required to provide security within 14 days of receiving notice of tender acceptance. The tenderer must furnish **EITHER**:
 - i) a Security Deposit as described in 1(b) above together with a Labour and Material Payment Bond in the amount of at least 50% of the amount payable under the contract, **OR**

- ii) a Performance Bond and a Labour and Material Payment Bond – each in the amount of 50% of the amount payable under the contract.
- 3b) Should it not be possible to obtain a Labour Material Payment Bond as required under 3(a) above, on making application thereof to at least two acceptable Bonding Companies, an additional Security Deposit of a straight 10% of the amount payable under the contract must be furnished.
- 3c) Where a tender has been accompanied by a Security Deposit, as described in 1(b) above, the amount of the Security Deposit required under 3(a) above may be reduced by the amount of the Security Deposit which accompanied the tender.
- 3d) Bonds must be in an approved form and from the companies whose

bonds are acceptable to the Government of Canada. Samples of the approved form of Bid Bond, Performance Bond and Labour and Material Payment Bond and a list of acceptable Bonding Companies may be obtained from the Contracting Officer, National Research Council, Building M-22, Montreal Road, Ottawa, Ontario, K1A 0R6.

Article 6 – Interest On Security Deposits

- 1) Tenderers are notified that they must make their own arrangements with their bankers as to the interest, if any, on the amount of the certified cheque accompanying their tender. The Council will not pay interest on said cheque pending the awarding of the contract nor be responsible for the payments of interest under any arrangement made by the tenderers.

Article 7 – Sales Tax

- 1) The amount of the tender shall include all taxes as levied under the Excise Act, the Excise Tax Act, the Old Age Security Act, the Customs Act or the Customs Tariff, in force or applicable at the time.
- 2) In Quebec, the Provincial Sales Tax should not be included in the Tender Price as the Federal Government is exempt. Tenderers should contact the Provincial Revenue Minister to recover all taxes paid for goods and services rendered under this contract.

Tenderers must include in their Tender Price the amount of Provincial Sales Tax for which the exemption does not apply.

Article 8 – Examination of Site

- 1) All parties tendering shall examine the sites of the proposed work before sending in their tender and make themselves thoroughly acquainted with the same and obtain for themselves any and all information that may be necessary for the proper carrying out of the Contract. No after claim will be allowed or entertained for any work or material that may be requisite and necessary for the proper execution and completion of this Contract with the exception of that provided for under GC 35 in the General Conditions of the General Specification.

Article 9 – Discrepancies, Omissions, Etc.

- 1a) Bidders finding discrepancies in, or omissions from, drawings, specifications or other documents, or having any doubt as to the meaning or intent of any part thereof, should at once notify the Engineer who will send written instructions or explanation to all bidders.
- 1b) Neither the Engineer nor the Council will be responsible for oral instructions.
- 1c) Addenda or corrections issued during the time of the bidding shall be covered in the proposal. However, the contract supersedes all communications, negotiations and agreements, either written or oral, relating to the work and made prior to the date of the contract.

Article 10 – No additional Payments for Increased Costs

- 1) The only other adjustments in the contract price allowed are those specified in the General Conditions of the General Specification. The contract price will not be amended for change in freight rates, exchange rates, wage rates or cost of materials, plant or services.

Article 11 – Awards

- 1a) The Council reserves the power and right to reject tenders received from parties who cannot show a reasonable acquaintance with and preparation for the proper performance of the class of work herein specified and shown on plans. Evidence of such competence must be furnished by the tenderers if required to do so.
- 1b) A tenderer may be required to furnish to the Contracting Office, National Research Council of Canada, Building M-22, 1200 Montreal Road, Ottawa, Ontario, K1A 0R6, Canada, unsigned copies of the insurance requirements as covered by the Insurance Conditions of the General Specification.
- 1c) The Council does not bind itself to accept the lowest or any tender.

Article 12 – Harmonized Sales Tax

- 1) The Harmonized Sales Tax (HST) which is now in effect shall be considered an applicable tax for the purpose of this tender. However, the bidder shall NOT include any amount in the bid price for said HST. The successful contractor will indicate on each application for payment as a separate amount the appropriate HST the Owner is legally obliged to pay. This amount will be paid to the Contractor in addition to the amount certified for payment under the Contract in addition to the amount certified for payment under the Contract and will therefore not affect the Contract Price. The Contractor agrees to remit any HST collected or due to Revenue Canada.

Non-resident contractors

RST guide 804

Published August 2006

ISBN: 1-4249-2007-8 (Print), **1-4249-2009-4 (PDF)**, **1-4249-2008-6 (HTML)**

Publication Archived

Notice to the reader: For Retail Sales Tax (RST) – On July 1, 2010 the 13 per cent Harmonized Sales Tax (HST) took effect in Ontario replacing the existing provincial Retail Sales Tax (RST) and combining it with the federal Goods and Services Tax (GST). As a result, RST provisions described on this page and in other publications ended on June 30, 2010.

Effective July 1, 2010 this publication was archived for RST purposes **only**. Use caution when you refer to it, since it reflects the law in force for RST at the time it was released and may no longer apply.

- The information in this Guide explains the Retail Sales Tax (RST) responsibilities of a non-resident contractor who is awarded a construction contract to perform work in Ontario and their Ontario customers. Please note that this Guide replaces the previous version dated March 2001.

Non-Resident Contractor Defined

A non-resident contractor is a contractor located outside Ontario who has been awarded a construction contract to perform work in Ontario, and who has not maintained a permanent place of business in Ontario continuously for twelve months immediately prior to signing the contract, or which is not a company incorporated under the laws of Ontario. A construction contract is a contract for the erection, remodelling or repair of a building or other structure on land.

A contractor is a person who is in the business of constructing, altering, repairing or improving real property and includes, but is not limited to,

1. a general contractor and subcontractor,
2. a carpenter, bricklayer, stonemason, electrician, plasterer, plumber, painter, decorator, paver, and bridge builder,
3. a sheet metal, tile and terrazzo, heating, air conditioning, insulation, ventilating, papering, road, roofing and cement contractor, who installs or incorporates items into real property. (See RST [Guide 206 - Real Property and Fixtures](#)).

Registration and Guarantee Deposit

Non-resident contractors who are awarded a construction contract in Ontario are required to register with the Ministry of Finance (ministry), Centralized Programs Unit and post a guarantee equal to 4 per cent of the total of each Ontario contract. The guarantee can be paid in cash, by certified cheque (payable to the Minister of Finance), letter of credit or by a guarantee bond.

To register with the ministry and to obtain further information on posting a guarantee, contractors should contact the ministry's Centralized Programs Unit, 33 King Street West, PO Box 623, Oshawa, Ontario, L1H 8H7, toll-free 1 866 ONT-TAXS (1 866 668-8297) or fax to 905 435-3617.

Non-resident contractors who sell taxable goods on a supply only basis to Ontario customers, or provide taxable services in Ontario, may obtain a regular Vendor Permit to collect and remit RST on their sales. Non-resident contractors who have been issued a regular Vendor Permit must still register separately with the ministry and post a guarantee if they are awarded a construction contract in Ontario.

Letter of Compliance

After receiving the guarantee, the ministry mails out two copies of a "letter of compliance" to the contractor certifying the Retail Sales Tax (RST) requirements have been met. Contractors must give a copy of the letter to their customers.

If a copy of the compliance letter is not provided, the customer must withhold 4 per cent of all amounts payable to the non resident contractor and pay the withheld amounts to the Minister of Finance (minister). Details relating to the contract should be sent along with the payments to the Centralized Programs Unit. Customers may give the minister a guarantee bond equal to 4 per cent of the total contract price instead of making the 4 per cent payments.

Note: Customers who do not follow these requirements may be held liable for 4 per cent of all amounts payable to the non resident contractor or any other amount that the Ministry deems to be the RST payable resulting from the performance of the contract.

Calculation of RST

Fair Value

RST is payable on the "fair value" of materials, purchased or brought into Ontario, to be used for work performed in Ontario. "Fair value" includes:

- the purchase price in Canadian funds;
- all charges by the supplier for handling and delivery, and
- any federal customs duties and excise taxes paid (but not the federal Goods and Services Tax (GST)).

Contractors are also required to pay RST to Ontario suppliers on the purchase, rental or lease of taxable services, materials, machinery, or equipment.

Machinery and Equipment - Leased

If machinery or equipment is leased from a supplier outside Ontario and brought into the province, RST is payable on the lease payments for the period the machinery or equipment is in Ontario.

Machinery and Equipment - Owned by Contractor

If machinery or equipment is owned by the contractor, RST may be calculated in one of the following ways:

- a. If a contractor brings machinery and equipment into Ontario for less than 12 months' use, RST is to be calculated using the following formula:

$$1/36 \times \text{net book value at date of import} \times \text{number of months in Ontario} \times \text{tax rate}$$

For the purpose of this formula, RST is payable for each month or part of a month that the goods are in Ontario. A month is considered 31 consecutive days and a part month is considered more than 12 days. The RST payable is based on the number of days the machinery and equipment are located in Ontario and not the number of days the items are actually used.

Example: Equipment is brought into Ontario on March 28 and taken out on May 8. The items were in the province for 41 days. RST is payable on the first 31 days' temporary stay in Ontario vs. use of the equipment. Since the remainder (10 days) is not considered part of a month, no RST is payable on this portion.

- b. If, at the time the goods are brought into Ontario, it is expected that the machinery or equipment will be in Ontario for more than twelve months, contractors must pay Retail Sales Tax (RST) on the following basis:

net book value at date of import × tax rate

If, at the time of import, the length of time is not known, vendors may use the formula under (a). If they later find it necessary to keep the machinery and equipment in Ontario for more than 12 months, the RST paid under (a) may be deducted from the RST payable under (b).

Using formula (a) or (b) above, contractors will calculate and remit the RST payable on the return that is filed when the contract is finished.

(See Completion of Contract section)

M a n u f a c t u r i n g f o r O w n U s e

Contractors may need to manufacture items, such as doors and windows, for their construction contracts. Manufacturing is work done in a factory away from a construction site, or in a mobile unit or workshop that is on or near the construction site. Manufacturing occurs when raw materials are changed into manufactured goods for use in real property contracts.

Contractors are considered to be manufacturing contractors if they produce goods:

1. for their own use in real property contracts, and
2. the manufactured cost of the goods is more than \$50,000 a year.

(See RST Guide 401 - Manufacturing Contractors)

C o n t r a c t s w i t h t h e F e d e r a l G o v e r n m e n t

Where a non-resident contractor enters into a construction contract with the federal government, for the construction of a building and/or the installation of equipment, the nature of the equipment will determine whether the contract should be let on a tax-included or tax excluded basis.

Contracts for the construction of a building and the installation of equipment that directly services that building (i.e., elevators, escalators, light fixtures, central heating and air conditioning, etc.) should be tendered on a tax -included basis. Contractors are the consumers of the materials used in fulfilling these contracts and must pay or account for RST on the materials used to complete the contracts. There is NO exemption just because the contract is with the federal government.

Contracts for the installation of equipment that becomes a fixture and does not directly service a building (i.e., material handling equipment, production machinery, communication equipment, training equipment) may be tendered on a tax-excluded basis. Contractors engaged in contracts of this nature are permitted to make tax exempt purchases of such equipment by issuing a valid Purchase Exemption Certificate (PEC) to their supplier. Only non-resident contractors who have registered with the ministry and posted a guarantee may issue a PEC.

E x e m p t i o n s

Contractors may supply and install equipment or materials for certain customers that may be entitled to an exemption from RST (e.g., manufacturers, Indian band councils, farmers and diplomatic organizations). The equipment or materials, when installed, becomes real property if it is permanently attached to land, or a fixture if it is permanently attached to a building or real property structure. Since

contractors are liable for RST, they should contact the ministry to find out if the customer qualifies for exemption before tendering the contract on a tax-excluded basis.

Status Indians, Indian Bands and Band Councils

Non-resident contractors may purchase building materials exempt from Retail Sales Tax (RST) for certain buildings and structures situated on reserves. The cost of such projects must be paid by the band council, and the buildings must provide a community service for the reserve. Contracts for the construction of an exempt community building project should be made on an RST-excluded basis. Non-resident contractors may purchase the materials exempt from RST by providing suppliers with a valid Purchase Exemption Certificate (PEC). As noted previously, only non-resident contractors who have registered with the ministry and posted a guarantee may issue a PEC. (See RST Guide [204 - Purchase Exemption Certificates](#)).

Non-resident contractors must pay RST on items purchased for incorporation into a building or structure built for individual status Indians on a reserve. (See RST [Guide 808 - Status Indians, Indian Bands and Band Councils](#)).

Completion of Contract

When a contract is completed, non-resident contractors who were required to post a guarantee must complete a [Non-Resident Contractor Retail Sales Tax Return \[PDF - 92 KB\]](#) that is provided by the ministry.

If a contractor's guarantee was given in cash or by certified cheque, the amount of the deposit can be deducted from the RST liability owed by the contractor. If the liability is greater than the deposit, the amount remaining must be paid by the contractor. If the deposit is more than the liability, the contractor will receive a refund.

If a guarantee bond was posted instead of cash, the bond will be discharged once the RST liability is paid in full.

All returns are subject to audit.

Legislative References

- Retail Sales Tax Act, Subsections 19(2) and 39(3)(4) and (5)
- Regulation 1012 under the Act, Subsections 15.3(1)(2)(5)(6) and (7)
- Regulation 1013 under the Act, Sections 1 and 3

For More Information

The information contained in this publication is only a guideline. For more information, please contact the Ontario Ministry of Finance at 1 866 ONT-TAXS (1 866 668-8297) or visit our website at ontario.ca/finance.

Acceptable Bonding Companies

Published September 2010

The following is a list of insurance companies whose bonds may be accepted as security by the government.

1. Canadian Companies

- ACE INA Insurance
- Allstate Insurance Company of Canada
- Ascentus Insurance Ltd. (Surety only)
- Aviva Insurance Company of Canada
- AXA Insurance (Canada)
- AXA Pacific Insurance Company
- Canadian Northern Shield Insurance Company
- Certas Direct Insurance Company (Surety only)
- Chartis Insurance Company of Canada (formerly AIG Commercial Insurance Company of Canada)
- Chubb Insurance Company of Canada
- Commonwealth Insurance Company
- Co-operators General Insurance Company
- CUMIS General Insurance Company
- The Dominion of Canada General Insurance Company
- Echelon General Insurance Company (Surety only)
- Economical Mutual Insurance Company
- Elite Insurance Company
- Everest Insurance Company of Canada
- Federated Insurance Company of Canada
- Federation Insurance Company of Canada
- Gore Mutual Insurance Company
- Grain Insurance and Guarantee Company
- The Guarantee Company of North America
- Industrial Alliance Pacific General Insurance Corporation
- Intact Insurance Company
- Jevco Insurance Company (Surety only)
- Lombard General Insurance Company of Canada
- Lombard Insurance Company
- Markel Insurance Company of Canada
- The Missisquoi Insurance Company
- The Nordic Insurance Company of Canada
- The North Waterloo Farmers Mutual Insurance Company (Fidelity only)
- Novex Insurance Company (Fidelity only)
- The Personal Insurance Company
- Pilot Insurance Company
- Quebec Assurance Company
- Royal & Sun Alliance Insurance Company of Canada
- Saskatchewan Mutual Insurance Company
- Scottish & York Insurance Co. Limited
- The Sovereign General Insurance Company
- TD General Insurance Company
- Temple Insurance Company
- Traders General Insurance Company

- Travelers Guarantee Company of Canada
- Trisura Guarantee Insurance Company
- The Wawanesa Mutual Insurance Company
- Waterloo Insurance Company
- Western Assurance Company
- Western Surety Company

2. Provincial Companies

Surety bonds issued by the following companies may be accepted provided that the contract of suretyship was executed in a province in which the company is licensed to do business as indicated in brackets.

- AXA Boreal Insurance Company (P.E.I., N.B., Que., Ont., Man., B.C.)
- AXA Boreal Insurance Company (P.E.I., N.B., Que., Ont., Man., B.C.)
- ALPHA, Compagnie d'Assurances Inc. (Que.)
- Canada West Insurance Company (Ont., Man., Sask, Alta., B.C., N.W.T.) (Surety only)
- The Canadian Union Assurance Company (Que.)
- La Capitale General Insurance Inc. (Nfld. & Lab., N.S., P.E.I., Que.(Surety only), Man., Sask., Alta., B.C., Nun., N.W.T., Yuk.)
- Coachman Insurance Company (Ont.)
- Continental Casualty Company (Nfld. & Lab., N.S., P.E.I., N.B., Que., Ont., Man., Sask., Alta., B.C., Nun., N.W.T., Yuk.)
- GCAN Insurance Company (Nfld. & Lab., N.S., P.E.I., N.B., Que., Ont., Man., Sask., Alta., B.C., Nun., N.W.T., Yuk.)
- The Insurance Company of Prince Edward Island (N.S., P.E.I., N.B.)
- Kingsway General Insurance Company (N.S., N.B., Que., Ont., Man., Sask., Alta., and B.C.)
- Liberty Mutual Insurance Company (Nfld. & Lab., N.S., P.E.I., N.B., Que., Ont., Man., Sask., Alta., B.C., Nun., N.W.T., Yuk.)
- Manitoba Public Insurance Corporation (Man.)
- Norgroupe Assurance Générales Inc.
- Orleans General Insurance Company (N.B., Que., Ont.)
- Saskatchewan Government Insurance Office (Sask.)
- SGI CANADA Insurance Services Ltd. (Ont., Man., Sask., Alta.)
- L'Unique General Insurance Inc. (Nfld. & Lab., N.S., P.E.I., N.B., Que.(Surety only), Ont.(Surety only), Man., Sask., Alta., B.C.(Surety only), Nun., N.W.T., Yuk.)

3. Foreign Companies

- Aspen Insurance UK Limited
- Compagnie Française d'Assurance pour le Commerce Extérieur (Fidelity only)
- Eagle Star Insurance Company Limited
- Ecclesiastical Insurance Office Public Limited Company (Fidelity only)
- Lloyd's Underwriters
- Mitsui Sumitomo Insurance Company, Limited
- NIPPONKOA Insurance Company, Limited
- Sompo Japan Insurance Inc.
- Tokio Marine & Nichido Fire Insurance Co., Ltd.
- XL Insurance Company Limited (Surety only)
- Zurich Insurance Company Ltd

Articles of Agreement

Standard Construction Contract – Articles of Agreement
(23/01/2002)

- A1 Contract Documents
- A2 Date of Completion of Work and Description of Work
- A3 Contract Amount
- A4 Contractor's Address
- A5 Unit Price Table

Articles of Agreement

These Articles of Agreement made in duplicate this day of .

Between

Her Majesty the Queen, in right of Canada (referred to in the contract documents as “ Her Majesty”) represented by the National Research Council Canada (referred to in the contract documents as the “Council”)

and

(referred to in the contract documents as the “Contractor”)

Witness that in consideration for the mutual promises and obligations contained in the contract, Her Majesty and the Contractor covenant and agree as follows:

A1 Contract Documents

(23/01/2002)

1.1 Subject to A1.4 and A1.5, the documents forming the contract between Her Majesty and the Contractor, referred to herein as the contract documents, are

1.1.1 these Articles of Agreement,

1.1.2 the document attached hereto, marked “A” and entitled “Plans and Specifications”, referred to herein as the Plans and Specifications,

1.1.3 the document attached hereto, marked “B” and entitled “Terms of Payment”, referred to herein as the Terms of Payment,

1.1.4 the document attached hereto, marked “C” and entitled “General Conditions”, referred to herein as the General Conditions,

1.1.5 the document attached hereto, marked “D” and entitled “Labour Conditions”, referred to herein as the Labour Conditions,

1.1.6 the document attached hereto, marked “E” and entitled “Insurance Conditions”, referred to herein as the Insurance Conditions,

1.1.7 the document attached hereto, marked “F” and entitled “Contract Security Conditions”, referred to herein as the Contract Security Conditions, and

1.1.8 any amendment or variation of the contract documents that is made in accordance with the General Conditions.

1.1.9 the document entitled Fair Wage Schedules for Federal Construction Contracts referred to herein as Fair Wage Schedules

1.1.10

Articles of Agreement

The Council hereby designates _____ of _____ of the Government of Canada as the Engineer for the purposes of the contract, and for all purposes of or incidental to the contract, the Engineer's address shall be deemed to be:

1.2 In the contract

1.3.1 "Fixed Price Arrangement" means that part of the contract that prescribes a lump sum as payment for performance of the work to which it relates; and

1.3.2 "Unit Price Arrangement" means that part of the contract that prescribes the product of a price multiplied by a number of units of measurement of a class as payment for performance of the work to which it relates.

1.3 Any of the provisions of the contract that are expressly stipulated to be applicable only to a Unit Price Arrangement are not applicable to any part of the work to which a Fixed Price Arrangement is applicable.

1.4 Any of the provisions of the contract that are expressly stipulated to be applicable only to a Fixed Price Arrangement are not applicable to any part of the work to which a Unit Price Arrangement is applicable.

A2 Date of Completion of Work and Description of Work

(23/01/2002)

2.1 The contractor shall, between the date of these Articles of Agreement and the _____, _____, in the careful and workmanlike manner, diligently perform and complete the following work:

which work is more particularly described in the Plans and Specifications.

Articles of Agreement

A3 Contract Amount

(23/01/2002)

- 3.1 Subject to any increase, decrease, deduction, reduction or set-off that may be made under the Contract, Her Majesty shall pay the Contractor at the times and in the manner that is set out or referred to in the Terms of Payment
- 3.1.1 the sum of _____ (GST/HST extra), in consideration for the performance of the work or the part thereof that is subject to Fixed Price Arrangement, and
- 3.1.2 a sum that is equal to the aggregate of the products of the number of units of Measurement of each class of labour, plant and material that is set out in a Final Certificate of Measurement referred to in GC44.8 multiplied in each case by the appropriate unit price that is set out in the Unit Price Table in consideration for the performance of the work or the part thereof that is subject to a Unit Price Arrangement.
- 3.2 For the information and guidance of the Contractor and the persons administering the contract on behalf of Her Majesty, but not so as to constitute a warranty , representation or undertaking of any nature by either party, it is estimated that the total amount payable by Her Majesty to the Contractor for the part of the work to which a Unit Price Arrangement is applicable will be approximately \$N/A
- 3.3 A3.1.1 is applicable only to a Fixed Price Arrangement.
- 3.4 A3.1.2 and A3.2 applicable only to a Unit Price Arrangement.

A4 Contractor's Address

(23/01/2002)

- 4.1 For all purposes of or incidental to the contract, the Contractor's address shall be deemed to be:

Articles of Agreement

A5 Unit Price Table

(23/01/2002)

5.1 Her Majesty and the Contractor agree that the following table is the Unit Price Table for the purposes of the contract.

Column 1 Item	Column 2 Class of Labour Plant Or Material	Column 3 Unit of Measurement	Column 4 Estimated Total Quantity	Column 5 Price per Unit	Column 6 Estimated Total Price
		N/A			

5.2 The Unit Price Table that is set out in A5.1 designates the part of the work to which a Unit Price Arrangement is applicable.

5.3 The part of the work that is not designated in the Unit Price Table referred to in A5.2 is the part of the work to which a Fixed Price Arrangement is applicable.

Articles of Agreement

Signed on behalf of Her Majesty by

as Senior Contracting Officer

and _____

as _____

of the **National Research Council Canada**

on the _____

day of _____

Signed, sealed and delivered by

as _____ and
Position

by _____

as _____ and
Position

of

on the _____

day of _____

Seal

<u>Section 00 01 10 - Table of Contents</u>	1
<u>Section 00 01 00 – General Instructions</u>	13
<u>Section 21 05 01 - General and Fire Safety Requirements</u>	6
<u>Section 21 05 01 - Common Work Results For Mechanical</u>	5
<u>Section 21 07 19 - Thermal Insulation for Piping</u>	4
<u>Section 22 11 16 - Domestic Water Piping</u>	3
<u>Section 23 05 05 - Installation Of Pipework</u>	5
<u>Section 23 05 17 - Pipe Welding</u>	4
<u>Section 23 05 29 - Hangers And Supports For HVAC Piping And Equipment</u>	8
<u>Section 23 07 13 - Duct Insulation</u>	5
<u>Section 23 22 13 - Steam and Condensate Heating Piping</u>	4
<u>Section 23 23 00 - Copper Tubing and Fittings Process Piping</u>	3
<u>Section 23 31 13 - Metal Ducts - Low Pressure To 500 Pa</u>	5
<u>Section 23 33 00 - Air Duct Accessories</u>	4
<u>Section 23 33 15 - Dampers - Operating</u>	2
<u>Section 26 05 00- Common Work Results – Electrical</u>	2
<u>Section 26 05 21 - Wires and Cables (0-1000V)</u>	2
<u>Section 26 05 22 - Connectors and Terminations</u>	2
<u>Section 26 05 32 - Outlet Boxes, Conduit Boxes and Fittings</u>	2
<u>Section 26 05 33 - Raceways for Electrical Systems</u>	2
<u>Section 26 24 01 - Service Equipment</u>	2
<u>Section 26 27 26 - Wiring Devices</u>	2
<u>Section 26 50 00 - Lighting</u>	2
<u>Section 28 31 00 - Fire Alarm Systems</u>	5
<u>Section 32 31 13 - Chain Link Fences and Gates</u>	5

END OF TABLE

1. SCOPE OF WORK

- .1 Work under this contract covers the construction of a new compressed air and oxygen system in the Council's Building M50 of the National Research Council.

2. DRAWINGS

- .1 The following drawings illustrate the work and form part of the contract documents:

5200-M01	DEMOLITION AND NEW COMPRESSED AIR AND OXYGEN TUBING AND EQUIPMENT LAYOUT5
5200-M02	EXTERIOR ELEVATION LAYOUT
5200-M03	EXTERIOR LAYOUT OF NEW INTAKES AND EXISTING BUILDING AREA
5200-M04	BASEMENT OXYGEN TUBING LAYOUT AND SCHEDULES
5200-M05	NEW COMPRESSED AIR AND OXYGEN SCHEMATIC
5200-M06	ELEVATION AND MECHANICAL DETAILS
5200-M07	DETAILS AND SCHEDULES
5200-M08	MECHANICAL DETAILS
5200-E01	POWER NEW AND DEMOLITION
5200-E02	POWER, LIGHTING AND FIRE ALARM NEW WORK

3. COMPLETION

- .1 Complete all work within 12 week(s) after receipt of notification of acceptance of tender.

4. GENERAL

- .1 The word "provide" in this Specification means to supply and install.
.2 Provide items mentioned in either the drawings or the specification.

5. SPECIFIED ACCEPTABLE & ALTERNATIVE EQUIPMENT & MATERIALS

- .1 Materials and equipment scheduled and/or specified on the drawings or in the specifications have been selected to establish a performance and quality standard. In most cases, acceptable manufacturers are stated for any material or equipment specified by manufacturer's name and model number. Contractors may base their tender price on materials and equipment supplied by any of the manufacturers' names as acceptable for the particular material or equipment.
.2 In addition to the manufacturers specified or named as acceptable, you may propose alternative manufacturers of materials or equipment to the Departmental Representative for acceptance. For a product to be considered as an alternative product substitute, make a written application to the Departmental Representative during the tender period, not later than ten (10) working days before tender closing.

- .3 Certify in writing that the alternative meets all requirements of the specified material or equipment. In addition, it shall be understood that all costs required by or as a result of acceptance or proposed alternatives, will be borne by the contractor.
- .4 Approval of alternatives will be signified by issue of an Addendum to the Tender Documents.
- .5 Any alternative manufacturers or materials submitted which are incomplete and cannot be evaluated, or are later than ten (10) working days before tender closing date or after the tender period, will not be considered.

6. MINIMUM STANDARDS

- .1 Conform to or exceed minimum acceptable standards of the various applicable federal, provincial and municipal codes such as The National Building Code, The National Fire Code, Canadian Plumbing Code, Canadian Electrical Code, Canadian Code for Construction Safety and the Provincial Construction Safety Act.
- .2 Work to conform to referenced standards and codes as reaffirmed or revised to date of specification.

7. WORKPLACE HAZARDOUS MATERIAL INFORMATION SYSTEM (WHMIS)

- .1 The general contractor shall comply with Federal and Provincial legislation regarding the WHMIS. The contractor's responsibilities include, but are not limited to the following:
 - .1 To ensure that any controlled product brought on site by the contractor or sub-contractor is labeled;
 - .2 To make available to the workers and the Departmental Representative, Material Safety Data Sheets (MSDS) for these controlled products;
 - .3 To train own workers about WHMIS, and about the controlled products that they use on site;
 - .4 To inform other contractors, sub-contractors, the Departmental Representative, authorized visitors and outside inspection agency personnel about the presence and use of such products on the site.
 - .5 The site foreman or superintendent must be able to demonstrate, to the satisfaction of the Departmental Representative, that he/she has had WHMIS training and is knowledgeable in its requirements. The Departmental Representative can require replacement of this person if this condition or implementation of WHMIS is not satisfactory.

8. REQUIREMENTS OF BILL 208, SECTION 18(a)

Under the requirements of Bill 208 of the Ontario Ministry of Labour Occupational Health & Safety Act, the following designated substances may be encountered while performing the work described in these contract documents:

- .1 Acrylonitrile, Isocyanates, Arsenic, Lead, Asbestos, Mercury, Benzene, Silica, Coke Oven Emissions, Vinyl Chloride, and Ethylene Oxide

- .1 It is the responsibility of the general contractor to ensure that each prospective subcontractor for this project has received a copy of the above list.

9. COST BREAKDOWN

- .1 Submit, for approval by the Departmental Representative, a cost breakdown of tender 72 hours after the contract is awarded.
- .2 Use the approved cost breakdown as the basis for submitting all claims.
- .3 Request Departmental Representative's verbal approval to amount of claim prior to preparing and submitting the claim in its final form.

10. SUB-TRADES

- .1 Submit no later than 72 hours after tender closing, a complete list of sub trades for the Departmental Representative's review.

11. PERSONNEL SECURITY AND IDENTIFICATION

- .1 All persons employed by the contractor, or by any subcontractor and present on the site must be security cleared in accordance with the requirements of the Section entitled Special Instructions to Tenderers.
- .2 All such persons must wear and keep visible identification badges as issued by the Security Office of NRC.

12. WORKING HOURS AND SECURITY

- .1 Normal working hours on the NRC property are from 8:00 a.m. until 4:30 p.m., Monday to Friday inclusive, except statutory holidays.
- .2 At all other times, special written passes are required for access to the building site.
- .3 Before scheduling any work outside normal working hours, obtain permission from the Departmental Representative to perform the specific tasks.
- .4 An escort may be required whenever working outside normal hours. Contractor to bear the associated costs.

13. SCHEDULE

- .1 The contractor shall prepare a detailed schedule, fixing the date for commencement and completion of the various parts of the work and update the said schedule. Such schedule shall be made available to the Departmental Representative not later than two weeks after the award of the contract and prior to commencement of any work on site.
- .2 Notify Departmental Representative in writing of any changes in the schedule.

.77 day(s) before the scheduled completion date, arrange to do an interim inspection with the Departmental Representative.

14. PROJECT MEETINGS

- .1 Hold regular project meetings at times and locations approved by the Departmental Representative.
- .2 Notify all parties concerned of meetings to ensure proper coordination of work.
- .3 Departmental Representative will set times for project meetings and assume responsibility for recording and distributing minutes.

15. SHOP DRAWINGS

- .1 Submit to Departmental Representative for review, shop drawings, product data and samples specified within 2 week(s) after contract award.
- .2 Submit to Departmental Representative for review a complete list of all shop drawings, product data and samples specified and written confirmation of corresponding delivery dates within one (1) week after shop drawings, product data and samples approval date. This list shall be updated on a 2 week basis and any changes to the list shall be immediately notified in writing to the Departmental Representative.
- .3 Review shop drawings, data sheets and samples prior to submission.
- .4 Submit electronic copy of all shop drawings and product data and samples for review, unless otherwise specified.
- .5 Review of shop drawings and product data by the Departmental Representative does not relieve the contractor of the responsibility for errors and omissions and for the conformity with contract documents.

16. SAMPLES AND MOCK-UPS

- .1 Submit samples in sizes and quantities as specified.
- .2 Where colour, pattern or texture is criterion, submit full range of samples.
- .3 Construct field samples and mock-ups at locations acceptable to Departmental Representative.
- .4 Reviewed samples or mock-ups will become standards of workmanship and material against which installed work will be checked on the project.

17. MATERIALS AND WORKMANSHIP

- .1 Install only new materials on this project unless specifically noted otherwise.
- .2 Only first class workmanship will be accepted, not only with regard to safety, efficiency, durability, but also with regard to neatness of detail and performance.

18. WORK & MATERIALS SUPPLIED BY OWNER

- .1 Work and materials not included in this contract are described on drawings and in this specification.
- .2 Deliver to a storage place, as directed by the Departmental Representative, all materials returned to the Owner.
- .3 Unless otherwise specified, accept owner-supplied materials at their storage location and provide all transportation as required.
- .4 General Contractor's duties:
 - .1 Unload at site.
 - .2 Promptly inspect products and report damaged or defective items.
 - .3 Give written notification to the Departmental Representative for items accepted in good order.
 - .4 Handle at site, including uncrating and storage.
 - .5 Repair or replace items damaged on site.
 - .6 Install, connect finished products as specified.

19. SITE ACCESS

- .1 Make prior arrangements with the Departmental Representative before starting work or moving materials and equipment on site.
- .2 Obtain approval of Departmental Representative for regular means of access during the construction period.
- .3 Obtain approval of Departmental Representative before temporarily suspending operations on site; before returning to the site and before leaving the site at the end of the job.
- .4 Provide and maintain access to site.
- .5 Build and maintain temporary roads and provide snow removal during period of work.
- .6 Make good any damage and clean up dirt, debris, etc., resulting from contractor's use of existing roads.

20. USE OF SITE

- .1 Restrict operations on the site to the areas approved by the Departmental Representative
- .2 Locate all temporary structures, equipment, storage, etc., to the designated areas.
- .3 Restrict parking to the designated areas.

21. ACCEPTANCE OF SITE

- .1 Inspect the site before commencing work, review any unexpected conditions with the Departmental Representative.

- .2 Commencement of work will imply acceptance of existing conditions.

22. SITE OFFICE & TELEPHONE

- .1 Contractor to erect a temporary site office at his own expense.
- .2 Install and maintain a telephone, if necessary.
- .3 Use of NRC phones is not permitted unless in the case of an emergency.

23. SANITARY FACILITIES

- .1 Obtain permission from the Departmental Representative to use the existing washroom facilities in the building

24. TEMPORARY SERVICES

- .1 A source of temporary power will be made available in the area. Bear all costs to make connections to the power source and perform distribution on site.
- .2 Provide all load centres, breakers, conduit, wiring, disconnects, extension cords, transformers, as required from the source of power.
- .3 Power is to be used only for power tools, lighting, controls, motors, and not for space heating.
- .4 A source of temporary water will be made available if required.
- .5 Bear all costs associated with distributing the water to the required locations.
- .6 Comply with NRC requirements when connecting to existing systems in accordance with the articles entitled "Co-operation" and "Service Interruptions" of this section.

25. DOCUMENTS REQUIRED AT WORK SITE

- .1 The contractor shall keep on the site, one (1) up-to-date copy of all contract documents, including specifications, drawings, addenda, shop drawings, change notices, schedule and any reports or bulletins pertaining to the work, in good order, available to the Departmental Representative and to his / her representatives at all times.
- .2 At least one (1) copy of specifications and drawings shall be marked by the contractor to show all work "As Built" and shall be provided to the Departmental Representative with the Application for Payment and for the Final Certificate of Completion.

26. CO-OPERATION

- .1 Co-operate with NRC staff in order to keep disruption of normal research work to an absolute minimum.
- .2 Work out in advance, a schedule for all work which might disrupt normal work in the building.

- .3 Have schedule approved by the Departmental Representative.
- .4 Notify the Departmental Representative in writing, 72 hours prior to any intended interruption of facilities, areas, corridors, mechanical or electrical services and obtain requisite permission.

27. PROTECTION AND WARNING NOTICES

- .1 Provide all materials required to protect existing equipment.
- .2 Erect dust barriers to prevent dust and debris from spreading through the building.
- .3 Place dust protection in the form of cover sheets over equipment and furniture and tape these sheets to floors, to ensure no dust infiltration.
- .4 Repair or replace any and all damage to Owner's property caused during construction, at no cost to the Owner and to the satisfaction of the Departmental Representative.
- .5 Protect the buildings, roads, lawns, services, etc. from damage which might occur as a result of this work.
- .6 Plan and co-ordinate the work to protect the buildings from the leakage of water, dust, etc.
- .7 Ensure that all doors, windows, etc., that could allow transfer of dust, noise, fumes, etc., to other areas of the building are kept closed.
- .8 Be responsible for security of all areas affected by the work under the Contract until acceptance by NRC. Take all necessary precautions to prevent entry to the work area by unauthorized persons and guard against theft, fire and damage by any cause. Secure working area at the end of each day's work and be responsible for same.
- .9 Provide and maintain adequate safety barricades around the work sites to protect NRC personnel and the public from injury during the construction.
- .10 Post warnings, in all instances where possible injury could occur such as Work Overhead, Hard Hat Areas, etc. or as required by the Departmental Representative.
- .11 Provide temporary protective enclosures over building entrances and exits to protect pedestrians. All enclosures to be structurally sound against weather and falling debris.

28. BILINGUALISM

- .1 Ensure that all signs, notices, etc. are posted in both official languages.
- .2 Ensure that all identification of services called for by under this contract are bilingual.

29. LAYOUT OF WORK

- .1 Location of equipment, fixtures, outlets and openings indicated on drawings or specified are to be considered as approximate.

- .2 Locate equipment, fixtures and distribution systems to provide minimum interference and maximum usable space and in accordance with the manufacturer's recommendations for safety, access and maintenance.
- .3 Employ competent person to lay out work in accordance with the contract documents.

30. DISCREPANCIES & INTERFERENCES

- .1 Prior to the start of the work, examine drawings and specifications. Report at once to the Departmental Representative, any defects, discrepancies, omissions or interferences affecting the work.
- .2 Contractor to immediately inform the Departmental Representative in writing, of any discrepancies between the plans and the physical conditions so the Departmental Representative may promptly verify same.
- .3 Any work done after such a discovery, until authorized, is at the contractor's risk.
- .4 Where minor interferences as determined by the Departmental Representative are encountered on the job and they have not been pointed out on the original tender or on the plans and specifications, provide offsets, bends or reroute the services to suit job conditions at no extra cost.
- .5 Arrange all work so as not to interfere in any way with other work being carried out.

31. MANUFACTURER'S INSTRUCTIONS

- .1 Unless otherwise specified, comply with manufacturer's latest printed instructions for materials and installation methods.
- .2 Notify the Departmental Representative in writing of any conflict between these specifications and manufacturer's instruction. Departmental Representative will designate which document is to be followed.

32. TEMPORARY HEATING AND VENTILATING

- .1 Bear the costs of temporary heat and ventilation during construction including costs of installation, fuel, operation, maintenance, and removal of equipment.
- .2 Use of direct-fired heaters discharging waste products into the work areas will not be permitted unless prior approval is given by the Departmental Representative.
- .3 Furnish and install temporary heat and ventilation in enclosed areas as required to:
 - .1 Facilitate progress of work.
 - .2 Protect work and products against dampness and cold.
 - .3 Reduce moisture condensation on surfaces to an acceptable level.
 - .4 Provide ambient temperature and humidity levels for storage, installation and curing of materials.

- .5 Provide adequate ventilation to meet health regulations for a safe working environment.
- .4 Maintain minimum temperature of 10 °C (50 °F) or higher where specified as soon as finishing work is commenced and maintain until acceptance by the Departmental Representative. Maintain ambient temperature and humidity levels as required for comfort of NRC personnel.
- .5 Prevent hazardous or unhealthy accumulations of dust, fumes, mists, vapours or gases in areas occupied during construction including also, storage areas and sanitary facilities.
 - .1 Dispose of exhaust materials in a manner that will not result in a harmful or unhealthy exposure to persons.
- .6 Maintain strict supervision of operation of temporary heating and ventilating equipment.
 - .1 Enforce conformance with applicable codes and standards.
 - .2 Comply with instructions of the Departmental Representative including provision of full-time watchman services when directed.
 - .3 Enforce safe practices.
 - .4 Vent direct-fired combustion units to outside.
- .7 Submit tenders assuming existing or new equipment and systems will not be used for temporary heating and ventilating.
- .8 After award of contract, Departmental Representative may permit use of the permanent system providing agreement can be reached on:
 - .1 Conditions of use, special equipment, protection, maintenance, and replacement of filters.
 - .2 Methods of ensuring that heating medium will not be wasted and in the case of steam, agreement on what is to be done with the condensate.
 - .3 Saving on contract price.
 - .4 Provisions relating to guarantees on equipment.

33. CONNECTIONS TO AND INTERRUPTIONS TO EXISTING SERVICES

- .1 Where work involves breaking into or connecting to existing services, carry out work at times and in the manner agreed to by the Departmental Representative and by authorities having jurisdiction, with minimum disruption to NRC Personnel and vehicular traffic and minimum service interruption. Do not operate any NRC equipment or plant.
- .2 Before commencing work, establish location and extent of service lines in area of work and notify Departmental Representative of findings.
- .3 Submit a schedule to and obtain approval from the Departmental Representative for any shut-down or closure of active service or facility; allow minimum 72 hours notice. Adhere to approved schedule and provide notice to the Departmental Representative.
- .4 Where unknown services are encountered, immediately advise Departmental Representative and confirm findings in writing.

- .5 Provide detours, bridges, alternate feeds, etc., as required to minimize disruptions.
- .6 Protect existing services as required and immediately make repairs if damage occurs.
- .7 Remove any abandoned service lines as indicated on the contract documents and as approved by the Departmental Representative; cap or otherwise seal lines at cut-off points. Record and provide a copy to the Departmental Representative of locations of maintained, re-routed and abandoned service lines.

34. CUTTING AND PATCHING

- .1 Cut existing surfaces as required to accommodate new work.
- .2 Remove all items as shown or specified.
- .3 Patch and make good with identical materials, the surfaces that have been disturbed, cut or damaged, to the satisfaction of the Departmental Representative.
- .4 Where new pipes pass through existing construction, core drill an opening. Size openings to leave 12mm (1/2") clearance around the pipes or pipe insulation. Do not drill or cut any surface without the approval of the Departmental Representative.
- .5 Obtain written approval of the Departmental Representative before cutting openings through existing or new structural members.
- .6 Seal all openings where cables, conduits or pipes pass through walls with an acoustic sealant conforming to CAN/CGSB-19.21-M87.
- .7 Where cables, conduits and pipes pass through fire rated walls and floors, pack space between with compressed glass fibres and seal with fire stop caulking in accordance with CAN/CGSB-19.13-M87 AND NBC 3.1.7.

35. FASTENING DEVICES

- .1 Do not use explosive actuated tools, without first obtaining permission from the Departmental Representative.
- .2 Comply with the requirements of CSA A-166 (Safety Code for Explosive Actuated Tools).
- .3 Do not use any kind of impact or percussion tool without first obtaining permission from the Departmental Representative.

36. OVERLOADING

- .1 Ensure that no part of the building or work is subjected to a load which will endanger safety or cause permanent deformation or structural damage.

37. DRAINAGE

- .1 Provide temporary drainage and pumping as required to keep excavations and site free of water.

38. ENCLOSURE OF STRUCTURES

- .1 Construct and maintain all temporary enclosures as required to protect foundations, sub-soil, concrete, masonry, etc., from frost penetration or damage.
- .2 Maintain in place until all chances of damage are over and proper curing has taken place.
- .3 Provide temporary weather tight enclosures for exterior openings until permanent sash and glazing and exterior doors are installed.
- .4 Provide lockable enclosures as required to maintain the security of NRC facilities and be responsible for the same.
- .5 Provide keys to NRC security personnel when required.
- .6 Lay out the work carefully and accurately and verify all dimensions and be responsible for them. Locate and preserve general reference points.
- .7 Throughout the course of construction, keep continuously acquainted with field conditions, and the work being developed by all trades involved in the project. Maintain an awareness of responsibility to avoid space conflict with other trades.
- .8 Conceal all services, piping, wiring, ductwork, etc., in floors, walls or ceilings except where indicated otherwise.

39. STORAGE

- .1 Provide storage as required to protect all tools, materials, etc., from damage or theft and be responsible for the same.
- .2 Do not store flammable or explosive materials on site without the authorization of the Departmental Representative.

40. GENERAL REVIEW

- .1 Periodic review of the contractor's work by the Departmental Representative does not relieve the contractor of the responsibility of making the work in accordance with contract documents. Contractor shall carry out his own quality control to ensure that the construction work is in accordance with contract documents.
- .2 Inform the Departmental Representative of any impediments to the installation and obtain his / her approval for actual location.

41. INSPECTION OF BURIED OR CONCEALED SERVICES

- .1 Prior to concealing any services that are installed, ensure that all inspection bodies concerned, including NRC, have inspected the work and have witnessed all tests. Failure to do so may result in exposing the services again at the contractor's expense.

42. TESTING

- .1 On completion, or as required by local authority inspectors and/or Departmental Representative during progress of work and before any services are covered up and flushing is complete, test all installations in the presence of the Departmental Representative.
- .2 Obtain and hand to the Departmental Representative all acceptance certificates or test reports from authority having jurisdiction. The project will be considered incomplete without the same.

43. PARTIAL OCCUPANCY

- .1 NRC may request partial occupancy of the facility if the contract extends beyond the expected completion date.
- .2 Do not restrict access to the building, routes, and services.
- .3 Do not encumber the site with materials or equipment.

44. DISPOSAL OF WASTES

- .1 Dispose of waste materials including volatiles, safely off NRC property. Refer to the section entitled "General and Fire Safety Requirements" included as part of this specification.

45. CLEAN-UP DURING CONSTRUCTION

- .1 On a daily basis, maintain project site and adjacent area of campus including roofs, free from debris and waste materials.
- .2 Provide on-site dump containers for collection of waste materials and rubbish.

46. FINAL CLEAN-UP

- .1 Upon completion do a final clean-up to the satisfaction of the Departmental Representative.
- .2 Clean all new surfaces, lights, existing surfaces affected by this work, replace filters, etc.
- .3 Clean all resilient flooring and prepare to receive protective finish. Protective finish applied by NRC

47. WARRANTY AND RECTIFICATION OF DEFECTS IN WORK

- .1 Refer to General Conditions "C", section GC32.
- .2 Ensure that all manufacturers' guarantees and warranties are issued in the name of the **General** Contractor and the National Research Council.

48. MAINTENANCE MANUALS

- .1 Provide three (3) bilingual copies of maintenance manuals or two English and two French maintenance manuals immediately upon completion of the work and prior to release of holdbacks.
- .2 Manuals to be neatly bound in hard cover loose leaf binders.
- .3 Manuals to include operating and maintenance instructions, all guarantees and warranties, shop drawings, technical data, etc., for the material and apparatus supplied under this contract.

END OF SECTION

1. GENERAL CONSTRUCTION SAFETY REQUIREMENTS

- .1 The Contractor shall take all necessary steps to protect personnel (workers, visitors, general public, etc.) and property from any harm during the course of the contract.
- .2 The Contractor shall be solely responsible for the construction safety of both its employees and those of its sub-contractors at the work site, and for initiating, maintaining and supervising safety precautions, programs and procedures in connection with the performance of the work.
- .3 The Contractor shall comply with all Federal, Provincial and Municipal safety codes and regulations and the Occupational Health and Safety Act and the Workplace Safety and Insurance Board. In the event of any conflict between any provisions in legislation or codes, the most stringent provisions shall apply.
- .4 Periodic review of the contractor's work by the Departmental Representative, using the criteria of the contract documents, does not relieve the contractor of his safety responsibilities in carrying out the work in accordance with the contract documents. The contractor shall consult with the Departmental Representative to ensure that this responsibility is carried out.
- .5 The Contractor shall ensure that only competent personnel are permitted to work on site. Throughout the term of the contract, any person will be removed from the site who is not observing or complying with the safety requirements.
- .6 All equipment shall be in safe operating condition and appropriate to the task.
- .7 Following a project and site hazard assessment, the Contractor shall develop a Site Specific Safety Plan based on the following minimum requirements:
 - .1 Provide a safety board mounted in a visible location on the project site, with the following information included thereon:
 - .1 Notice of Project
 - .2 Site specific Safety Policy
 - .3 Copy of Ontario Health and Safety Act
 - .4 Building Schematic showing emergency exits
 - .5 Building emergency procedures
 - .6 Contact list for NRC, Contractor and all involved sub-contractors
 - .7 Any related MSDS sheets
 - .8 NRC Emergency phone number
- .8 The Contractor shall provide competent personnel to implement its safety program and those of any Health and Safety Act legislation applicable at this project location, and to ensure they are being complied with.
- .9 The Contractor shall provide safety orientation to all its employees as well as those of any subcontractors under its jurisdiction.

- .10 The Departmental Representative will monitor to ensure that safety requirements are met and that safety records are properly kept and maintained. Continued disregard for safety standards can cause the contract to be cancelled and the Contractor or sub-contractors removed from the site.
- .11 The Contractor will report to the Departmental Representative and jurisdictional authorities, any accident or incident involving Contractor or NRC personnel or the public and/or property arising from the Contractor's execution of the work.
- .12 If entry to a laboratory is required as part of the work of the Contractor, a safety orientation shall be provided to all his employees as well as those of any subcontractors regarding lab safety requirements and procedures, as provided by the Researcher or the Departmental Representative.

2. FIRE SAFETY REQUIREMENTS

.1 Authorities

- 1. The Fire Commissioner of Canada (FC) is the authority for fire safety at NRC.
- 2. For the purpose of this document, "Departmental Representative" will be deemed as the NRC person in charge of the project and who will enforce these Fire Safety Requirements.
- 3. Comply with the following standards as published by the Office of the Fire Commissioner of Canada:
 - a. Standard No. 301 - June 1982 "Standard for Construction Operations";
 - b. Standard No. 302 - June 1982 "Standard for Welding and Cutting".

.2 Smoking

- .1 Smoking is prohibited inside all NRC buildings, as well as roof areas.
- .2 Obey all "NO SMOKING" signs on NRC premises.

.3 Hot Work

- .1 Prior to commencement of any "Hot Work" involving welding, soldering, burning, heating, use of torches or salamanders or any open flame, obtain a Hot Work Permit from the Departmental Representative.
- .2 Prior to commencement of "Hot Work", review the area of hot work with the Departmental Representative to determine the level of fire safety precautions to be taken.

.4 Reporting Fires

- .1 Know the exact location of the nearest Fire Alarm Pull Station and telephone, including the emergency phone number.
- .2 REPORT immediately, all fire incidents as follows:
 - .1 Activate nearest fire alarm pull station and;

.2 Telephone the following emergency phone number as appropriate:

FROM AN NRC PHONE	333
FROM ANY OTHER PHONE	(613) 993-2411

4. When reporting a fire by phone, give the location of fire, building number and be prepared to verify location.
5. The person activating fire alarm pull station must remain at a safe distance from the scene of the fire but readily available to provide information and direction to the Fire Department personnel.

.5 Interior and Exterior Fire protection & Alarm Systems

- .1 DO NOT OBSTRUCT OR SHUT OFF FIRE PROTECTION EQUIPMENT OR SYSTEMS, INCLUDING BUT NOT LIMITED TO FIRE ALARM SYSTEMS, SMOKE/HEAT DETECTORS, SPRINKLER SYSTEM, PULL STATIONS, EMERGENCY CALL BUTTONS AND PA SYSTEMS, WITHOUT AUTHORIZATION FROM THE DEPARTMENTAL REPRESENTATIVE.
- .2 WHEN ANY FIRE PROTECTION EQUIPMENT IS TEMPORARILY SHUT DOWN, ALTERNATIVE MEASURES AS PRESCRIBED BY THE DEPARTMENTAL REPRESENTATIVE SHALL BE TAKEN TO ENSURE THAT FIRE PROTECTION IS MAINTAINED.
- .3 DO NOT LEAVE FIRE PROTECTION OR ALARM SYSTEMS INACTIVE AT THE END OF A WORKING DAY WITHOUT NOTIFICATION AND AUTHORISATION FROM THE DEPARTMENTAL REPRESENTATIVE. THE DEPARTMENTAL REPRESENTATIVE WILL ADVISE THE (FPO) OF THE DETAILS OF ANY SUCH EVENT.
- .4 DO NOT USE FIRE HYDRANTS, STANDPIPES AND HOSE SYSTEMS FOR OTHER THAN FIRE FIGHTING PURPOSES UNLESS AUTHORISED BY DEPARTMENTAL REPRESENTATIVE.

.6 Fire Extinguishers

- .1 Provide a minimum of 1-20 lb. ABC Dry Chemical Fire Extinguisher at each hot work or open flame location.
- .2 Provide fire extinguishers for hot asphalt and roofing operations as follows:
 - a. Kettle area - 1-20 lb. ABC Dry Chemical;
 - b. Roof - 1-20 lb. ABC Dry Chemical at each open flame location.
- .3 Provide fire extinguishers equipped as below:
 - c. Pinned and sealed;
 - d. With a pressure gauge;
 - e. With an extinguisher tag signed by a fire extinguisher servicing company.

- .4 Carbon Dioxide (CO₂) extinguishers will not be considered as substitutes for the above.

.7 Roofing Operations

.1 Kettles:

- .1 Arrange for the location of asphalt kettles and material storage with the Departmental Representative before moving on site. Do not locate kettles on any roof or structure and keep them at least 10m (30 feet) away from a building.
- .2 Equip kettles with 2 thermometers or gauges in good working order; a hand held and a kettle-mounted model.
- .3 Do not operate kettles at temperatures in excess of 232°C (450 °F).
- .4 Maintain continuous supervision while kettles are in operation and provide metal covers for the kettles to smother any flames in case of fire. Provide fire extinguishers as required in article 2.6.
- .5 Demonstrate container capacities to Departmental Representative prior to start of work.
- .6 Store materials a minimum of 6m (20 feet) from the kettle.

.2 Mops:

- .1 Use only glass fibre roofing mops.
- .2 Remove used mops from the roof site at the end of each working day.

.3 Torch Applied Systems:

- .1 DO NOT USE TORCHES NEXT TO WALLS.
- .2 DO NOT TORCH MEMBRANES TO EXPOSED WOOD OR CAVITY
- .3 Provide a Fire Watch as required by article 2.9 of this section.

- .4 Store all combustible roofing materials at least 3m (10 feet) away from any structure.

- .5 Keep compressed gas cylinders a minimum of 6m (20 feet) away from the kettle, protected from mechanical damage and secured in an upright position.

.8 Welding / Grinding Operations

- .1 Contractor to provide fire blankets, portable fume extraction devices, screens or similar equipment to prevent exposure to welding flash, or sparks from grinding.

.9 Fire Watch

- .1 Provide a fire watch for a minimum of one hour after the termination of any hot work operation.
- .2 For temporary heating, refer to General Instructions Section 00 010 00.
- .3 Equip fire watch personnel with fire extinguishers as required by article 2.6.

.10 Obstruction of access/egress routes-roadways, halls, doors, or elevators

- .1 Advise the Departmental Representative in advance of any work that would impede the response of Fire Department personnel and their apparatus. This includes violation of minimum overhead clearance, erection of barricades and the digging of trenches.
- .2 Building exit routes must not be obstructed in any way without special permission from the Departmental Representative, who will ensure that adequate alternative routes are maintained.
- .3 The Departmental Representative will advise the FPO of any obstruction that may warrant advanced planning and communication to ensure the safety of building occupants and the effectiveness of the Fire Department.

.11 Rubbish and Waste Materials

- .1 Keep rubbish and waste materials to a minimum and a minimum distance of 6m (20 feet) from any kettle or torches.
- .2 Do not burn rubbish on site.
- .3 Rubbish Containers
 - .1 Consult with the Departmental Representative to determine an acceptable safe location for any containers and the arrangement of chutes etc. prior to bringing the containers on site.
 - .2 Do not overfill the containers and keep area around the perimeter free and clear of any debris.
- .4 Storage
 - .1 Exercise extreme care when storing combustible waste materials in work areas. Ensure maximum possible cleanliness, ventilation and that all safety standards are adhered to when storing any combustible materials.
 - .2 Deposit greasy or oily rags or materials subject to spontaneous combustion in CSA or ULC approved receptacles and remove at the end of the work day or shift, or as directed.

.12 Flammable Liquids

- .1 The handling, storage and use of flammable liquids is governed by the current National Fire Code of Canada.
- .2 Flammable Liquids such as gasoline, kerosene and naphtha may be kept for ready use in quantities not exceeding 45 litres (10 imp gal), provided they are stored in approved safety cans bearing the ULC seal of approval and kept away from buildings, stockpiled combustible materials etc. Storage of quantities of flammable liquids exceeding 45 litres (10 imp gal) for work purposes, require the permission of the Departmental Representative.

- .3 Flammable liquids are not to be left on any roof areas after normal working hours.
- .4 Transfer of flammable liquids is prohibited within buildings.
- .5 Do not transfer flammable liquids in the vicinity of open flames or any type of heat producing device.
- .6 Do not use flammable liquids having a flash point below 38 °C (100 °F) such as naphtha or gasoline as solvents or cleaning agents.
- .7 Store flammable waste liquids for disposal in approved container located in a safe, ventilated area. Waste flammable liquids are to be removed from the site on a regular basis.
- .8 Where flammable liquids, such as lacquers or urethane are used, ensure proper ventilation and eliminate all sources of ignition. Inform the Departmental Representative prior to, and at the cessation of such work.

3. Questions and/or clarifications

- .1 Direct any questions or clarification on Fire or General Safety, in addition to the above requirements, to the Departmental Representative.

END OF SECTION

Part 1 General

1.1 SUBMITTALS

- .1 Submittals: in accordance with Section 00 10 00 – General Instructions.
- .2 Shop drawings to show:
 - .1 Mounting arrangements.
 - .2 Operating and maintenance clearances.
- .3 Shop drawings and product data accompanied by:
 - .1 Detailed drawings of bases, supports, and anchor bolts.
 - .2 Acoustical sound power data, where applicable.
 - .3 Points of operation on performance curves.
 - .4 Manufacturer to certify current model production.
 - .5 Certification of compliance to applicable codes.
- .4 Closeout Submittals:
 - .1 Provide operation and maintenance data for incorporation into manual specified in Section 00 10 00 – General Instructions.
 - .2 Operation and maintenance manual approved by, and final copies deposited with, Departmental Representative before final inspection.
 - .3 Operation data to include:
 - .1 Control schematics for systems including environmental controls.
 - .2 Description of systems and their controls.
 - .3 Description of operation of systems at various loads together with reset schedules and seasonal variances.
 - .4 Operation instruction for systems and component.
 - .5 Description of actions to be taken in event of equipment failure.
 - .6 Valves schedule and flow diagram.
 - .7 Colour coding chart.
 - .4 Maintenance data to include:
 - .1 Servicing, maintenance, operation and trouble-shooting instructions for each item of equipment.
 - .2 Data to include schedules of tasks, frequency, tools required and task time.
 - .5 Performance data to include:
 - .1 Equipment manufacturer's performance datasheets with point of operation as left after commissioning is complete.
 - .2 Equipment performance verification test results.
 - .3 Special performance data as specified.
 - .4 Testing, adjusting and balancing reports as specified in Section 23 05 93 - Testing, Adjusting and Balancing for HVAC.
 - .6 Approvals:

- .1 Submit 2 copies of draft Operation and Maintenance Manual to Departmental Representative for approval. Submission of individual data will not be accepted unless directed by Departmental Representative.
- .2 Make changes as required and re-submit as directed by Departmental Representative.
- .7 Additional data:
 - .1 Prepare and insert into operation and maintenance manual additional data when need for it becomes apparent during specified demonstrations and instructions.
- .8 Site records:
 - .1 Departmental Representative will provide 1 set of reproducible mechanical drawings. Provide sets of white prints as required for each phase of work. Mark changes as work progresses and as changes occur. Include changes to existing mechanical systems, control systems and low voltage control wiring.
 - .2 Transfer information weekly to reproducibles, revising reproducibles to show work as actually installed.
 - .3 Use different colour waterproof ink for each service.
 - .4 Make available for reference purposes and inspection.
- .9 As-built drawings:
 - .1 Prior to start of Testing, Adjusting and Balancing for HVAC, finalize production of as-built drawings.
 - .2 Identify each drawing in lower right hand corner in letters at least 12 mm high as follows: - "AS BUILT DRAWINGS: THIS DRAWING HAS BEEN REVISED TO SHOW MECHANICAL SYSTEMS AS INSTALLED" (Signature of Contractor) (Date).
 - .3 Submit to Departmental Representative for approval and make corrections as directed.
 - .4 Perform testing, adjusting and balancing for HVAC using as-built drawings.
 - .5 Submit completed reproducible as-built drawings with Operating and Maintenance Manuals.
- .10 Submit copies of as-built drawings for inclusion in final TAB report.

1.2 DEFINITIONS

- .1 For purposes of this the Mechanical Division the following:
 - .1 "Concealed" - mechanical services and equipment in suspended ceilings and in chases and furred spaces.
 - .2 "Exposed" - will mean not concealed as defined above.

1.3 EXAMINATION OF THE SITE

- .1 Carefully examine conditions at the site which the site will or may affect your work, and become familiar with both the new and existing construction, finishes, and other work associated with your work in order that your tender price includes for everything necessary for completion of your work within the proposed project schedule

1.4 QUALITY ASSURANCE

- .1 Quality Assurance: in accordance with Section 00 10 00 – General Instructions.
- .2 Health and Safety Requirements: do construction occupational health and safety in accordance with Section 00 10 00 – General Instructions and 00 15 45 – General Safety Section and Fire Instructions.

1.5 MAINTENANCE

- .1 Furnish spare parts in accordance with Section 00 10 00 – General Instructions.

1.6 DELIVERY, STORAGE, AND HANDLING

- .1 Waste Management and Disposal:
 - .1 Construction/Demolition Waste Management and Disposal: in accordance with Section 00 10 00 – General Instructions and Section 00 15 45 – General Safety Section and Fire Instructions.

1.7 COORDINATION & COOPERATION WITH OTHER TRADES

- .1 Co-ordinate your work with the work of all trades to ensure a proper and complete installation. Notify all trades concerned of the requirement for openings, sleeves, inserts and other hardware necessary in their work for the installation of your work.
- .2 The exact locations and routing of mechanical and electrical services must be properly planned, coordinated and established with all affected trades prior to installation such that they will clear each other as well as any obstructions. Generally, piping requiring uniform pitch shall be given the right of way, with other services located and arranged to suit.

1.8 PERMITS, CERTIFICATES & FEES

- .1 Display all required permits on worksite and include copies of inspection certificates in operating and maintenance instruction manuals.
- .2 Obtain "Hot Work Permit" from the Engineer prior to commencement of soldering, welding or other high temperature work.
- .3 Comply with all requirements of Section 001000.

1.9 FEDERAL HALOCARBON REGULATION

- .1 Generate halocarbon records for work on equipment (cooling equipment with CFC's, HCFC's and HFC refrigerants; fire suppression systems; solvent cleaning systems) that may result in the release of a halocarbon.
- .2 Tag equipment with duplicate of halocarbon record.
- .3 Provide additional copy of halocarbon record to NRC for inclusion in the Zone Halocarbon Service File.

1.10 CLEANING & FINAL ADJUSTMENT

- .1 During construction, keep the site reasonably clear of rubbish and waste material resulting from your work on a daily basis to the satisfaction of the Engineer. Notify the general contractor of any requirements for a waste receptacle for disposal of waste materials.
- .2 Clean interior and exterior of all systems including strainers, and vacuum interior of air handling units.
- .3 Clean and refurbish all equipment and leave in first class operating condition including replacement of all filters in all air and piping systems.
- .4 Balance and adjust all systems and each piece of equipment to operate as designed.

1.11 STORAGE OF EQUIPMENT & MATERIALS

- .1 Arrange for sufficient storage facilities off the premises for the storage of equipment and materials which will not be allowed to stand in the open, nor to interfere with normal operations in the building.
- .2 Bring prefabricated materials on the job site as and when required to be installed.

1.12 HOISTING & SCAFFOLDING

- .1 Provide all necessary hoists and scaffolds required for your work.
- .2 Design and construction of scaffolding to be in accordance with CSA S269.2
- .3

Part 2 Products

2.1 MATERIALS

- .1 Materials and products in accordance with Section 00 10 00 – General Instructions.

Part 3 Execution

3.1 PAINTING REPAIRS AND RESTORATION

- .1 Do painting in accordance with Section 09 91 23 - Interior Painting.
- .2 Prime and touch up marred finished paintwork to match original.
- .3 Restore to new condition, finishes which have been damaged.

3.2 CLEANING

- .1 Clean interior and exterior of all systems including strainers. Vacuum interior of ductwork and air handling units.

3.3 FIELD QUALITY CONTROL

- .1 Site Tests: conduct following tests in accordance with Section 00 10 00 – General Instructions and submit report as described in PART 1 - SUBMITTALS.
- .2 Manufacturer's Field Services:
 - .1 Obtain written report from manufacturer verifying compliance of Work, in handling, installing, applying, protecting and cleaning of product and submit Manufacturer's Field Reports as described in PART 1 - SUBMITTALS.
 - .2 Provide manufacturer's field services consisting of product use recommendations and periodic site visits for inspection of product installation in accordance with manufacturer's instructions.
 - .3 Schedule site visits, to review Work, as directed in PART 1 - QUALITY ASSURANCE.

3.4 DEMONSTRATION (If Required)

- .1 Departmental Representative will use equipment and systems for test purposes prior to acceptance. Supply labour, material, and instruments required for testing.
- .2 Trial usage to apply to following equipment and systems:
 - .1 Fume hood and associated services.
- .3 Supply tools, equipment and personnel to demonstrate and instruct operating and maintenance personnel in operating, controlling, adjusting, trouble-shooting and servicing of all systems and equipment during regular work hours, prior to acceptance.
- .4 Use operation and maintenance manual, as-built drawings, and audio visual aids as part of instruction materials.
- .5 Instruction duration time requirements as specified in appropriate sections.
- .6 Determination of whether or not demonstration is required will be decided by Departmental Representative in consultation with end user (client).

3.5 PROTECTION

- .1 Protect equipment and systems openings from dirt, dust, and other foreign materials with materials appropriate to system.

END OF SECTION

Part 1

General

1.1 SUMMARY

- .1 Section Includes:
 - .1 Thermal insulation for piping and piping accessories.

1.2 REFERENCES

- .1 American Society of Heating, Refrigeration and Air Conditioning Engineers (ASHRAE)
 - .1 ASHRAE Standard 90.1, Energy Standard for Buildings Except Low-Rise Residential Buildings.
- .2 Health Canada/Workplace Hazardous Materials Information System (WHMIS)
 - .1 Material Safety Data Sheets (MSDS).
- .3 Manufacturer's Trade Associations
 - .1 Thermal Insulation Association of Canada (TIAC): National Insulation Standards (Revised 2004).

1.3 DEFINITIONS

- .1 For purposes of this section:
 - .1 "CONCEALED" - insulated mechanical services in suspended ceilings and non-accessible chases and furred-in spaces.
 - .2 "EXPOSED" - will mean "not concealed" as specified.

1.4 SUBMITTALS

- .1 Submittals: in accordance with Section 00 10 00 – General Instructions.
- .2 Product Data:
 - .1 Submit manufacturer's printed product literature, specifications and datasheet. Include product characteristics, performance criteria, and limitations.
 - .1 Submit two copies of Workplace Hazardous Materials Information System (WHMIS) Material Safety Data Sheets (MSDS).
- .3 Shop Drawings:
 - .1 Submit shop drawings in accordance with Section 00 10 00 – General Instructions.
 - .1 Shop drawings: submit drawings stamped for review by NRC.
- .4 Samples:
 - .1 Samples: Required with shop drawing/s.

1.5 QUALITY ASSURANCE

- .1 Qualifications:
- .2 Installer: specialist in performing work of this Section, and have at least 3 years successful experience in this size and type of project, member of TIAC.
- .3 Health and Safety:
 - .1 Do construction occupational health and safety in accordance with Section 00 10 00 – General Instructions.

1.6 DELIVERY, STORAGE AND HANDLING

- .1 Packing, shipping, handling and unloading:
 - .1 Deliver, store and handle materials in accordance with manufacturer's written instructions.
 - .2 Deliver materials to site in original factory packaging, labelled with manufacturer's name, address.
- .2 Storage and Protection:
 - .1 Protect from weather, theft, construction traffic.
 - .2 Protect against damage.

- .3 Store at temperatures and conditions required by manufacturer.
- .3 Waste Management and Disposal:
 - .1 Remove all material from NRC property and dispose, reuse and recycle excel material as per local good waste management practices.
 - .2 Place excess or unused insulation and insulation accessory materials in designated containers.

Part 2

Products

2.1

FIRE AND SMOKE RATING

- .1 In accordance with CAN/ULC-S102.
 - .1 Maximum flame spread rating: 25.
 - .2 Maximum smoke developed rating: 50.

2.2

INSULATION

- .1 Code A-1:
 - .1 Rigid moulded mineral fibre without factory applied vapour retarder jacket:
 - .2 Jacket shall be suitable to be painted with future latex paint.
 - .3 Products properties: ASTM C547
 - .4 Temperature Range: 0 to 650 °C
 - .5 Nominal Density kg/m³: 128
 - .6 Maximum "k" factor: 0.049 W/m²K at 300°C to ASTM C 335.
 - .7 Standard of acceptance: Manufacturer: Roxul, Model: ProRox PS 960.
- .2 Code A-3:
 - .1 Rigid moulded mineral fibre with factory applied vapour retarder jacket.
 - .2 Vapor retarder jacket includes a continuous longitudinal self-sealing closure lap.
 - .3 Jacket shall be suitable to be painted with future latex paint.
 - .4 Mineral fibre: CAN/ULC S102-M88
 - .5 Jacket: to CGSB 51-GP-9M, self-sealing lap.
 - .6 Temperature Range: 0 to 454 °C
 - .7 Maximum "k" factor: 0.079 W/m²K at 260°C to ASTM C 335.
 - .8 Standard of acceptance: Manufacturer: Johns Manville- Micto-Lok HP.
- .3 TIAC Code C-2: Mineral fibre blanket with factory applied vapour retarder jacket.
 - .1 Mineral fibre: ASTM C553.
 - .2 Jacket: to CGSB 51-GP-52Ma.
 - .3 Maximum "k" factor: ASTM C553.

2.3

INSULATION SECUREMENT

- .1 Tape: self-adhesive, aluminum 50 mm wide minimum.
- .2 Contact adhesive: quick setting.
- .3 Canvas adhesive: washable.
- .4 Tie wire: 1.5mm diameter stainless steel
- .5 Single: stainless steel, 19 mm wide x 0.5 mm thick bands.
- .6 Wire mesh: 25 mm hexagonal type 304 stainless steel wire mesh, tightly laced together at horizontal and circumferential mesh joints.

2.4 VAPOUR RETARDER LAP ADHESIVE

- .1 Water based, fire retardant type, compatible with insulation.

2.5 INDOOR VAPOUR RETARDER FINISH

- .1 Vinyl emulsion type acrylic, compatible with insulation.

2.6 OUTDOOR VAPOUR RETARDER FINISH

- .1 Vinyl emulsion type acrylic, compatible with insulation.
- .2 Reinforcing fabric: fibrous glass, untreated 305 g/m².

2.7 JACKETS

- .1 Canvas:
 - .1 220 gm/m² cotton, plain weave, treated with dilute fire retardant lagging adhesive to ASTM C921.
 - .2 Lagging adhesive: compatible with insulation.

Part 3 Execution

3.1 MANUFACTURER'S INSTRUCTIONS

- .1 Compliance: comply with manufacturer's written recommendations or specifications, including product technical bulletins, handling, storage and installation instructions, and datasheet.

3.2 PRE-INSTALLATION REQUIREMENT

- .1 Pressure testing of piping systems and adjacent equipment to be complete, witnessed and certified by NRC.
- .2 Piping to be inspected and approved by NRC.
- .3 Surfaces clean, dry, free from foreign material.

3.3 INSTALLATION

- .1 Install in accordance with TIAC National Standards.
- .2 Apply materials in accordance with manufacturer's instructions and this specification.
- .3 When using two layers staggered joints (minimal 100mm overlap).
- .4 Maintain uninterrupted continuity and integrity of vapour retarder jacket and finishes.
 - .1 Install hangers, supports outside vapour retarder jacket.
- .5 Supports, Hangers: See drawing. Stainless Steel bands: to be installed on exterior layer of insulation, maximum spacing 600mm o.c.
- .7 Tie wire: to be used on interior layer, maximum spacing 300mm o.c.
- .8 Contractor shall insulate: Valve body, Steam moisture separator

3.4 PIPING INSULATION SCHEDULES

- .1 Includes valves, valve bonnets, strainers, flanges and fittings unless otherwise specified.
- .2 TIAC Code:
 - .1 Securements: SS bands at 400 mm on centre.
 - .2 Seals: VR lap seal adhesive, VR lagging adhesive.
 - .3 Installation: TIAC Code: 1501-H.

- .3 Thickness of insulation:
 - .1 Run-outs to individual units and equipment not exceeding 4000 mm long.
 - .2 Steam:
 - .1 38mm thick layer
 - .3 Condensate: Insulation Code A-3.
 - .1 25mm thick layer
 - .4 Domestic Water piping: Insulation Code A-3
 - .1 25mm
- .4 Insulation Finishes Jacket: Canvas

3.5 CLEANING

- .1 Proceed in accordance with Section 00 10 00 – General Instructions.
- .2 Upon completion and verification of performance of installation, remove surplus materials, excess materials, rubbish, tools and equipment.

END OF SECTION

Part 1

General

1.1

SUMMARY

- .1 Section Includes:
 - .1 Selection of piping valves in domestic water system.

1.2

RELATED SECTIONS

- .1 23 05 01 - Installation of Pipework

1.3

REFERENCES

- .1 American National Standards Institute (ANSI)/American Society of Mechanical Engineers International (ASME)
 - .1 ANSI/ASME B16.15, Cast Bronze Threaded Fittings, Classes 125 and 250.
 - .2 ANSI/ASME B16.18, Cast Copper Alloy Solder Joint Pressure Fittings.
 - .3 ANSI/ASME B16.22, Wrought Copper and Copper Alloy Solder Joint Pressure Fittings.
 - .4 ANSI/ASME B16.24, Cast Copper Alloy Pipe Flanges and Flanged Fittings, Class 150, 300, 400, 600, 900, 1500 and 2500.
- .2 American National Standards Institute/American Water Works Association (ANSI)/(AWWA)
 - .1 ANSI/AWWA C111/A21.11, Rubber-Gasket Joints for Ductile-Iron Pressure Pipe and Fittings.
- .3 Canadian Standards Association (CSA International)
 - .1 CSA B242, Groove and Shoulder Type Mechanical Pipe Couplings.
- .4 Department of Justice Canada (Jus)
 - .1 Canadian Environmental Protection Act, 1999, c. 33 (CEPA).
- .5 Health Canada/Workplace Hazardous Materials Information System (WHMIS)
 - .1 Material Safety Data Sheets (MSDS).
- .6 Manufacturer's Standardization Society of the Valve and Fittings Industry (MSS).
 - .1 MSS-SP-67, Butterfly Valves.
 - .2 MSS-SP-70, Gray Iron Gate Valves, Flanged and Threaded Ends.
 - .3 MSS-SP-71, Gray Iron Swing Check Valves, Flanged and Threaded Ends.
 - .4 MSS-SP-80, Bronze Gate, Globe, Angle and Check Valves.
- .7 National Research Council (NRC)/Institute for Research in Construction
 - .1 NRCC 38728, National Plumbing Code of Canada (NPC) .
- .8 Transport Canada (TC)
 - .1 Transportation of Dangerous Goods Act, 1992, c. 34 (TDGA).

1.4 ACTION AND INFORMATIONAL SUBMITTALS

- .1 Provide manufacturer shop drawings for all valves, piping, fittings and as specified on drawings and in section 01000
- .2 Product Data:
 - .1 Provide manufacturer's printed product literature and datasheets for insulation and adhesives, and include product characteristics, performance criteria, physical size, finish and limitations.

1.5 DELIVERY, STORAGE AND HANDLING

- .1 See section 01000

Part 2 Products

2.1 PIPING

- .1 Domestic hot, cold and recirculation systems, within building.
 - .1 Above ground: copper tube, hard drawn, type L: to ASTM B88M.
 - .2 Buried or embedded: copper tube, soft annealed, type K: to ASTM B88M. No buried joints.

2.2 FITTINGS

- .1 Wrought copper and copper alloy, solder type: to ANSI/ASME B16.22. NPS 2 and larger: roll grooved to CSA B242.
- .3 Cast bronze threaded fittings, Class 150: to ANSI/ASME B16.15.
- .4 Cast copper, solder type: to ANSI/ASME B16.18.
- .5 Bronze pipe flanges and flanged fittings, Class 150 to ANSI/ASME B16.24.

2.3 JOINTS

- .1 Solder: 95% tin / 5% copper alloy.
- .2 Teflon tape: for threaded joints.
- .3 Dielectric connections between dissimilar metals: dielectric fitting, complete with thermoplastic liner.

Part 3 Execution

3.1 APPLICATION

- .1 Manufacturer's Instructions: comply with manufacturer's written recommendations, including product technical bulletins, handling, storage and installation instructions, and datasheets.

3.2 INSTALLATION

- .1 Install in accordance with Ontario Plumbing Code.
- .2 Install pipe work in accordance with Section 23 05 01 - Installation of Pipework, supplemented as specified herein.
- .3 Assemble piping using fittings manufactured to ANSI standards.
- .4 Install CWS piping below and away from HWS and HWC and other hot piping so as to maintain temperature of cold water as low as possible.
- .5 Connect to fixtures and equipment in accordance with manufacturer's written instructions unless otherwise indicated.
- .6 Buried tubing:
 - .1 Lay in well compacted washed sand in accordance with AWWA Class B bedding.
 - .2 Bend tubing without crimping or constriction. Minimize use of fittings.
- .7 Install valves with unions at each piece of equipment arranged to allow servicing, maintenance and equipment removal.

3.3 VALVES

- .1 Isolate equipment with unions, fixtures and branches with gate valves.
- .2 Provide valves as indicated on drawing and in specifications.
- .3 Balance recirculation system using balancing valve. Mark settings and record on as-built drawings on completion.
- .4 Provide line size check valve on discharge of all pumps.

3.4 PRESSURE TESTS

- .1 Test pressure: Hydrostatic test pressure (1.5 times maximum working pressure), Pneumatic test pressure (1.2 maximum working pressure pending NRC approval) for a minimum of 15 minutes. All tests must be witnessed and approved by NRC.
- .2 Provide NRC with a minimum of 48 hours notice in writing before all pressure tests.

END OF SECTION

Part 1 GENERAL

1.1 NOT USED

Part 2 PRODUCTS

2.1 NOT USED

Part 3 EXECUTION

3.1 APPLICATION

- .1 Manufacturer's Instructions: comply with manufacturer's written recommendations, including product technical bulletins, handling, storage and installation instructions, and datasheets.

3.2 CONNECTIONS TO EQUIPMENT

- .1 In accordance with manufacturer's instructions unless otherwise indicated.
- .2 Use valves and either unions or flanges for isolation and ease of maintenance and assembly.
 - .1 Unions are not required in installations using grooved mechanical couplings (The couplings shall serve as unions).
- .3 Use double swing joints when equipment mounted on vibration isolation and when piping subject to movement.
- .4 The flexible type grooved joint couplings may be used in lieu of a flexible connector at equipment connections for vibration attenuation and stress relief. Couplings shall be placed in close proximity to the source of the vibration, as per manufacturer's recommendations.

3.3 CLEARANCES

- .1 Provide clearance around systems, equipment and components for observation of operation, inspection, servicing, maintenance and as recommended by manufacturer.
- .2 Provide space for disassembly, removal of equipment and components as recommended by manufacturer or as indicated (whichever is greater) without interrupting operation of other system, equipment, components.

3.4 DRAINS

- .1 Install piping with grade in direction of flow except as indicated.
- .2 Install drain valve at low points in piping systems, at equipment and at section isolating valves.

- .3 Pipe each drain valve discharge separately to above floor drain. Discharge to be visible.
- .4 Drain valves: NPS 3/4 gate or globe valves unless indicated otherwise, with hose end male thread, cap and chain.

3.5 AIR VENTS

- .1 Install automatic air vents at high points in piping systems.
- .2 Install isolating valve at each automatic air valve.
- .3 Install drain piping to approved location and terminate where discharge is visible.

3.6 DIELECTRIC COUPLINGS

- .1 General: compatible with system, to suit pressure rating of system.
- .2 Locations: where dissimilar metals are joined.
- .3 NPS 2 and under: Isolating unions or bronze valves.
- .4 Over NPS 2: Isolating flanges.

3.7 PIPEWORK INSTALLATION

- .1 Screwed fittings jointed with Teflon tape.
- .2 Protect openings against entry of foreign material.
- .3 Install to isolate equipment and allow removal without interrupting operation of other equipment or systems.
- .4 Assemble piping using fittings manufactured to ANSI standards.
- .5 Saddle type branch fittings may be used on mains if branch line is no larger than half size of main.
 - .1 Hole saw (or drill) and ream main to maintain full inside diameter of branch line prior to welding saddle.
- .6 Install exposed piping, equipment, rectangular cleanouts and similar items parallel or perpendicular to building lines.
- .7 Install concealed pipework to minimize furring space, maximize headroom, conserve space.
- .8 Slope piping, except where indicated, in direction of flow for positive drainage and venting.
- .9 Install, except where indicated, to permit separate thermal insulation of each pipe.
- .10 Group piping wherever possible and as indicated.
- .11 Ream pipes, remove scale and other foreign material before assembly.

- .12 Use eccentric reducers at pipe size changes to ensure positive drainage and venting.
- .13 Provide for thermal expansion as indicated.
- .14 Valves:
 - .1 Install in accessible locations.
 - .2 Remove interior parts before soldering.
 - .3 Install with stems above horizontal position unless otherwise indicated.
 - .4 Valves accessible for maintenance without removing adjacent piping.
 - .5 Install globe valves in bypass around control valves.
 - .6 Use ball or butterfly valves at branch take-offs for isolating purposes except where otherwise specified.
 - .7 Install butterfly valves on chilled water and related condenser water systems only.
 - .8 Install butterfly valves between weld neck flanges to ensure full compression of liner.
 - .9 Install ball valves for glycol service.
 - .10 Use chain operators on valves 65 DN and larger where installed more than 2400 mm above floor in Mechanical Rooms.
- .15 Check Valves:
 - .1 Install silent check valves on discharge of pumps and in vertical pipes with downward flow and elsewhere as indicated.
 - .2 Install swing check valves in horizontal lines on discharge of pumps and elsewhere as indicated.

3.8 SLEEVES

- .1 General: install where pipes pass through masonry, concrete structures, fire rated assemblies, and elsewhere as indicated.
- .2 Material: schedule 40 black steel pipe.
- .3 Construction: foundation walls and where sleeves extend above finished floors to have annular fins continuously welded on at mid-point.
- .4 Prior to coring hole in existing wall for sleeve, contractor shall radiographically examine concrete wall/ceiling to confirm if there are embedded mechanical and/or electrical equipment in the structural.
- .5 Sizes: 6 mm minimum clearance between sleeve and uninsulated pipe or between sleeve and insulation.
- .6 Installation:
 - .1 Concrete, masonry walls, concrete floors on grade: terminate flush with finished surface.
 - .2 Other floors: terminate 25 mm above finished floor.
 - .3 Before installation, paint exposed exterior surfaces with heavy application of zinc-rich paint to CAN/CGSB-1.181.

- .7 Sealing:
 - .1 Foundation walls and below grade floors: fire retardant, waterproof non-hardening mastic.
 - .2 Elsewhere: Provide space for firestopping. Maintain fire rating integrity.
 - .3 Sleeves installed for future use: fill with lime plaster or other easily removable filler.
 - .4 Ensure no contact between copper pipe or tube and sleeve.

3.9 ESCUTCHEONS

- .1 Install on pipes passing through walls, partitions, floors, and ceilings in finished areas.
- .2 Construction: one piece type with set screws. Chrome or nickel plated brass or type 302 stainless steel.
- .3 Sizes: outside diameter to cover opening or sleeve. Inside diameter to fit around pipe or outside of insulation if so provided.

3.10 PREPARATION FOR FIRE STOPPING

- .1 Material and installation within annular space between pipes, ducts, insulation and adjacent fire separation to Section 07 84 00 - Fire Stopping.
- .2 Uninsulated unheated pipes not subject to movement: No special preparation.
- .3 Uninsulated heated pipes subject to movement: wrap with non-combustible smooth material to permit pipe movement without damaging fire stopping material or installation.
- .4 Insulated pipes and ducts: ensure integrity of insulation and vapour barriers.

3.11 FLUSHING OUT OF PIPING SYSTEMS

- .1 In accordance with Section 23 08 02 - Cleaning and Start-up of Mechanical Piping Systems.
- .2 Before start-up, clean interior of piping systems in accordance with requirements of Section 01 74 11 - Cleaning supplemented as specified in relevant sections of other Divisions.
- .3 Preparatory to acceptance, clean and refurbish equipment and leave in operating condition, including replacement of filters in piping systems.

3.12 PRESSURE TESTING OF EQUIPMENT AND PIPEWORK

- .1 Advise Departmental Representative, 48 hours minimum prior to performance of pressure tests.
- .2 Pipework: test as specified in relevant sections of heating, ventilating and air conditioning work.
- .3 Maintain specified test pressure without loss for 4 hours minimum unless specified for longer period of time in relevant mechanical sections or on drawings.

- .4 Prior to tests, isolate equipment and other parts which are not designed to withstand test pressure or media.
- .5 Conduct tests in presence of Departmental Representative.
- .6 Pay costs for repairs or replacement, retesting, and making good. Departmental Representative to determine whether repair or replacement is appropriate.
- .7 Insulate or conceal work only after approval and certification of tests by Departmental Representative.

3.13 EXISTING SYSTEMS

- .1 Connect into existing piping systems at times approved by Owner's Representative.
- .2 Request written approval ten (10) working days minimum, prior to commencement of work.
- .3 Be responsible for damage to existing plant by this work.
- .4 Ensure daily clean-up of existing areas.

END OF SECTION

Part 1 GENERAL

1.1 REFERENCES

- .1 American National Standards Institute/American Society of Mechanical Engineers (ANSI/ASME)
 - .1 ANSI/ASME B31.1, Power Piping.
 - .2 ANSI/ASME B31.3, Process Piping.
 - .3 ANSI/ASME Boiler and Pressure Vessel Code:
 - .1 BPVC Section I: Power Boilers.
 - .2 BPVC Section V: Nondestructive Examination.
 - .3 BPVC Section IX: Welding and Brazing Qualifications.
- .2 American National Standards Institute/American Water Works Association (ANSI/AWWA)
 - .1 ANSI/AWWA C206, Field Welding of Steel Water Pipe.
- .3 American Welding Society (AWS)
 - .1 AWS C1.1M/C1.1, Recommended Practices for Resistance Welding.
 - .2 AWS Z49.1, Safety in Welding, Cutting and Allied Process.
 - .3 AWS W1, Welding Inspection Handbook..
- .4 Canadian Standards Association (CSA International)
 - .1 CSA W47.2-[M1987(R2008)], Certification of Companies for Fusion Welding of Aluminum.
 - .2 CSA W48, Filler Metals and Allied Materials for Metal Arc Welding.
 - .3 CSA B51, Boiler, Pressure Vessel and Pressure Piping Code.
 - .4 CSA-W117.2, Safety in Welding, Cutting and Allied Processes.
 - .5 CSA W178.1, Certification of Welding Inspection Organizations.
 - .6 CSA W178.2, Certification of Welding Inspectors.

1.2 QUALITY ASSURANCE

- .1 Qualifications:
 - .1 Welders:
 - .1 Welding qualifications in accordance with CSA B51.
 - .2 Use qualified and licensed welders possessing certificate for each procedure performed from authority having jurisdiction.
 - .3 All welders completing work shall be registered with Ontario Technical Standards and Safety Association (TSSA) and have valid up to date credentials for welding procedure used.
 - .4 Submit welder's qualifications to Departmental Representative prior to starting any welding.
 - .5 Each welder to possess identification symbol issued by authority having jurisdiction.

- .6 Certification of companies for fusion welding of aluminum in accordance with CSA W47.2.
- .2 Inspectors:
 - .1 Inspectors qualified to CSA W178.2.
- .3 Certifications:
 - .1 Registration of welding procedures in accordance with CSA B51.
 - .2 Copy of welding procedures available for inspection.
 - .3 Safety in welding, cutting and allied processes in accordance with CSA-W117.2.

Part 2 PRODUCTS

2.1 ELECTRODES

- .1 Electrodes: in accordance with CSA W48 Series.

Part 3 Execution

3.1 APPLICATION

- .1 Manufacturer's Instructions: comply with manufacturer's written recommendations, including product technical bulletins, handling, storage and installation instructions, and datasheets.

3.2 QUALITY OF WORK

- .1 Welding: in accordance with ANSI/ASME B31.1 B31.3, B 31.5, B31.9, ANSI/ASME Boiler and Pressure Vessel Code, Sections I and IX and ANSI/AWWA C206, using procedures conforming to AWS C1.1, and special procedures specified elsewhere in Mechanical Division and applicable requirements of provincial authority having jurisdiction.

3.3 INSTALLATION REQUIREMENTS

- .1 Identify each weld with welder's identification symbol.
- .2 Backing rings: Only permitted on piping greater than 600mm in diameter.
 - .1 Where used, fit to minimize gaps between ring and pipe bore.
 - .2 Do not install at orifice flanges.
- .3 Fittings:
 - .1 NPS 2 and smaller: install welding type sockets.
 - .2 Branch connections: install welding tees or forged branch outlet fittings.

3.4 INSPECTION AND TESTS - GENERAL REQUIREMENTS

- .1 Review weld quality requirements and defect limits of applicable codes and standards with Departmental Representative before work is started.

- .2 Formulate "Inspection and Test Plan" in co-operation with Departmental Representative.
- .3 Do not conceal welds until they have been inspected, tested and approved by inspector.
- .4 Provide for inspector to visually inspect welds during early stages of welding procedures in accordance with Welding Inspection Handbook. Repair or replace defects as required by codes and as specified.

3.5 SPECIALIST EXAMINATIONS AND TESTS

- .1 General:
 - .1 Perform examinations and tests by specialist qualified to CSA W178.1 and CSA W178.2 and accepted by Departmental Representative.
 - .2 To ANSI/ASME Boiler and Pressure Vessels Code, Section V, CSA B51 and requirements of authority having jurisdiction.
 - .3 Inspect and test percentage of welds as indicated in accordance with "Inspection and Test Plan" by non-destructive visual examination and magnetic particle (hereinafter referred to as "particle") tests and spot and full gamma ray radiographic (hereinafter referred to as "radiography") tests.
- .2 Hydrostatically test welds to ANSI/ASME B31.1 and or B31.3 as specified.
- .3 Visual examinations: include entire circumference of weld externally and wherever possible internally.
- .4 Failure of visual examinations:
 - .1 Upon failure of welds by visual examination, perform additional testing as directed by Departmental Representative of total of up to 10% additional welds, selected at random by Departmental Representative by radiographic and/or particle tests.
- .5 Full radiographic tests for piping systems.
 - .1 Spot radiography:
 - .1 Conduct spot radiographic examine a minimum of 10% of welds. Welds to be examined shall be selected by Departmental Representative.
 - .2 Radiographic film:
 - .1 Identify each radiographic film with date, location, name of welder, and submit to Owner's Representative. Replace film if rejected because of poor quality.
 - .3 Interpretation of radiographic films:
 - .1 By qualified radiographer.
 - .4 Failure of radiographic tests:
 - .1 Extend tests to all welds by welder responsible for failed examinations/tests.
- .6 Magnetic particle tests for piping systems as indicated.

3.6 DEFECTS CAUSING REJECTION

- .1 As described in ANSI/ASME B31.1/B31.3 and ANSI/ASME Boiler and Pressure Vessels Code.
- .2 In addition, chilled water systems below 1000 kPa:
 - .1 Undercutting greater than 0.8 mm adjacent to cover bead on outside of pipe.
 - .2 Undercutting greater than 0.8 mm adjacent to root bead on inside of pipe.
 - .3 Undercutting greater than 0.8 mm at combination of internal surface and external surface.
 - .4 Incomplete penetration and incomplete fusion greater than total length of 38 mm in 1500 mm length of weld depth of such defects being greater than 0.8 mm.
 - .5 Repair cracks and defects in excess of 0.8 mm in depth.
 - .6 Repair defects whose depth cannot be determined accurately on basis of visual examination or radiographic particle tests.

3.7 REPAIR OF WELDS WHICH FAILED TESTS

- .1 Re-inspect and re-test repaired or re-worked welds at Contractor's expense.

END OF SECTION

Part 1 General

1.1 SUMMARY

.1 Section Includes:

- .1 Concrete housekeeping pads, hangers and supports for mechanical piping, ducting and equipment.

1.2 REFERENCES

.1 American National Standards Institute/American Society of Mechanical Engineers (ANSI/ASME)

- .1 ANSI/ASME B31.1 / B31.3

.2 American Society for Testing and Materials International (ASTM)

- .1 ASTM A125, Specification for Steel Springs, Helical, Heat-Treated.
- .2 ASTM A307, Specification for Carbon Steel Bolts and Studs, 60,000 PSI Tensile Strength.
- .3 ASTM A563, Specification for Carbon and Alloy Steel Nuts.

.3 Manufacturer's Standardization Society of the Valves and Fittings Industry (MSS)

- .1 MSS SP58, Pipe Hangers and Supports - Materials, Design and Manufacture.
- .2 ANSI/MSS SP69, Pipe Hangers and Supports - Selection and Application.
- .3 MSS SP89, Pipe Hangers and Supports - Fabrication and Installation Practices.

1.3 SYSTEM DESCRIPTION

.1 Design Requirements:

- .1 Construct pipe hanger and support to manufacturer's recommendations utilizing manufacturer's regular production components, parts and assemblies.
- .2 Base maximum load ratings on allowable stresses prescribed by MSS SP58.ASME B31.1 or B31.3 as indicated.
- .3 Ensure that supports, guides, anchors do not transmit excessive quantities of heat to building structure.
- .4 Design hangers and supports to support systems under conditions of operation, allow free expansion and contraction, prevent excessive stresses from being introduced into pipework or connected equipment.
- .5 Provide for vertical adjustments after erection and during commissioning. Amount of adjustment in accordance with MSS SP58.

.2 Performance Requirements:

- .1 Design supports, platforms, catwalks, hangers, to withstand seismic where indicated.

1.4 SUBMITTALS

- .1 Submit shop drawings and product data for following items:
 - .1 Bases, hangers and supports.
 - .2 Connections to equipment and structure.
 - .3 Structural assemblies.
 - .4 Installation instructions
- .2 Closeout Submittals:
 - .1 Provide maintenance data for incorporation into manual.

1.5 DELIVERY, STORAGE, AND HANDLING

- .1 Waste Management and Disposal:
 - .1 The contractor is responsibility to coordinate and dispose of all waste material to local provincial and municipality requirements.
 - .2 It is the full responsibility of the contractor to insure that all construction material, equipment, tools, etc. are stored and used in a safe and reasonable manor as per good industry standards.
 - .3 The contractor is responsible for all damaged and stolen material, tools or equipment on site.
 - .4 The contractor is responsible for the delivery of all material, tools or equipment.

Part 2 Products

2.1 GENERAL

- .1 Fabricate hangers, supports and sway braces in accordance with ANSI B31.1 and MSS SP58.
- .2 Use components for intended design purpose only. Do not use for rigging or erection purposes.

2.2 PIPE HANGERS

- .1 Finishes:
 - .1 Pipe hangers and supports: galvanized-exterior and painted with zinc-rich paint – interior after manufacture.
 - .2 Use hot dipped galvanizing process.
 - .3 Ensure steel hangers in contact with copper piping are copper plated or epoxy coated.
- .2 Upper attachment structural: suspension from lower flange of I-Beam:

- .1 Cold piping NPS 2 maximum: malleable iron C-clamp with hardened steel cup point setscrew, locknut and carbon steel retaining clip.
 - .1 Rod: 9 mm UL listed
- .2 Cold piping NPS 2 1/2 or greater, hot piping: malleable iron beam clamp, eye rod, jaws and extension with carbon steel retaining clip, tie rod, nuts and washers, UL listed to MSS-SP58 and MSS-SP69.
- .3 Upper attachment structural: suspension from upper flange of I-Beam:
 - .1 Cold piping NPS 2 maximum: ductile iron top-of-beam C-clamp with hardened steel cup point setscrew, locknut and carbon steel retaining clip, UL listed to MSS SP69.
 - .2 Cold piping NPS 2 1/2 or greater, hot piping: malleable iron top-of-beam jaw-clamp with hooked rod, spring washer, plain washer and nut UL listed.
- .4 Upper attachment to concrete:
 - .1 Ceiling: carbon steel welded eye rod, clevis plate, clevis pin and cotters with weldless forged steel eye nut. Ensure eye 6 mm minimum greater than rod diameter.
 - .2 Concrete inserts: wedge shaped body with knockout protector plate UL listed to MSS SP69.
- .5 Hanger rods: threaded rod material to MSS SP58:
 - .1 Ensure that hanger rods are subject to tensile loading only.
 - .2 Provide linkages where lateral or axial movement of pipework is anticipated. Pipe attachments: material to MSS SP58:
 - .1 Attachments for steel piping: carbon steel [black][galvanized].
 - .2 Attachments for copper piping: copper plated black steel.
 - .3 Use insulation shields for hot pipework.
 - .4 Oversize pipe hangers and supports.
- .7 Adjustable clevis: material to MSS SP69 UL listed, clevis bolt with nipple spacer and vertical adjustment nuts above and below clevis.
 - .1 Ensure "U" has hole in bottom for rivetting to insulation shields
- .8 Yoke style pipe roll: carbon steel yoke, rod and nuts with cast iron roll, to MSS SP69.
- .9 U-bolts: carbon steel to MSS SP69 with 2 nuts at each end to ASTM A563.
 - .1 Finishes for steel pipework: galvanized.
 - .2 Finishes for copper, glass, brass or aluminum pipework: black with formed portion plastic coated or epoxy coated.
- .10 Pipe rollers: cast iron roll and roll stand with carbon steel rod to MSS SP69. Shop and field-fabricated assemblies.
 - .1 Trapeze hanger assemblies: MSS SP-89.
 - .2 Steel brackets: MSS SP-89.
 - .3 Sway braces for seismic restraint systems: to MSS SP-89.

2.3 RISER CLAMPS

- .1 Steel or cast iron pipe: galvanized steel to MSS SP58, type 42, UL listed.
- .2 Copper pipe: carbon steel copper plated to MSS SP58, type 42.
- .3 Bolts: to ASTM A307.
- .4 Nuts: to ASTM A563.

2.4 INSULATION PROTECTION SHIELDS

- .1 Insulated cold piping:
 - .1 64 kg/m³ density insulation plus insulation protection shield to: MSS SP69, galvanized sheet carbon steel. Length designed for maximum 3 m span.
- .2 Insulated hot piping:
 - .1 Curved plate 300 mm long, with edges turned up, welded-in centre plate for pipe sizes NPS 12 and over, carbon steel to comply with MSS SP69.

2.5 CONSTANT SUPPORT SPRING HANGERS

- .1 Springs: alloy steel to ASTM A125, shot peened, magnetic particle inspected, with +/-5% spring rate tolerance, tested for free height, spring rate, loaded height and provided with Certified Mill Test Report (CMTR).
- .2 Load adjustability: 10 % minimum adjustability each side of calibrated load. Adjustment without special tools. Adjustments not to affect travel capabilities.
- .3 Provide upper and lower factory set travel stops.
- .4 Provide load adjustment scale for field adjustments.
- .5 Total travel to be actual travel + 20%. Difference between total travel and actual travel 25 mm minimum.
- .6 Individually calibrated scales on each side of support calibrated prior to shipment, complete with calibration record.

2.6 VARIABLE SUPPORT SPRING HANGERS

- .1 Vertical movement: 13 mm minimum, 50 mm maximum, use single spring pre-compressed variable spring hangers.
- .2 Vertical movement greater than 50 mm: use double spring pre-compressed variable spring hanger with 2 springs in series in single casing.
- .3 Variable spring hanger complete with factory calibrated travel stops. Provide certificate of calibration for each hanger.

- .4 Steel alloy springs: to ASTM A125, shot peened, magnetic particle inspected, with +/-5 % spring rate tolerance, tested for free height, spring rate, loaded height and provided with CMTR.

2.7 EQUIPMENT SUPPORTS

- .1 Fabricate equipment supports not provided by equipment manufacturer from structural grade steel meeting requirements of [Section 05 12 23 - Structural Steel for Buildings](#). Submit calculations with shop drawings.

2.8 EQUIPMENT ANCHOR BOLTS AND TEMPLATES

- .1 Provide templates to ensure accurate location of anchor bolts.

2.9 PLATFORMS AND CATWALKS

2.10 HOUSE-KEEPING PADS

- .1 Provide 100 mm high concrete housekeeping pads for base-mounted equipment; size pads 100 mm larger than equipment; chamfer pad edges.
- .2 Concrete: to [Section 03 30 00 - Cast-in-place Concrete](#) by Divisions 3.

2.11 OTHER EQUIPMENT SUPPORTS

- .1 Fabricate equipment supports from structural grade steel meeting requirements of [Section 05 12 23 - Structural Steel for Buildings](#).
- .2 Submit structural calculations with shop drawings.

Part 3 Execution

3.1 MANUFACTURER'S INSTRUCTIONS

- .1 Compliance: comply with manufacturer's written recommendations or specifications, including product technical bulletins, handling, storage and installation instructions, and datasheet.

3.2 INSTALLATION

- .1 Install in accordance with:
 - .1 Manufacturer's instructions and recommendations.
- .2 Vibration Control Devices:
 - .1 Install on piping systems at pumps, boilers, chillers, cooling towers, and as indicated.
- .3 Clamps on riser piping:

- .1 Support independent of connected horizontal pipework using riser clamps and riser clamp lugs welded to riser.
- .2 Bolt-tightening torques to industry standards.
- .3 Steel pipes: install below coupling or shear lugs welded to pipe.
- .4 Cast iron pipes: install below joint.
- .4 Clevis plates:
 - .1 Attach to concrete with 4 minimum concrete inserts, one at each corner.
- .5 Provide supplementary structural steelwork where structural bearings do not exist or where concrete inserts are not in correct locations.
- .6 Use approved constant support type hangers where:
 - .1 vertical movement of pipework is 13 mm or more,
 - .2 transfer of load to adjacent hangers or connected equipment is not permitted.
- .7 Use variable support spring hangers where:
 - .1 transfer of load to adjacent piping or to connected equipment is not critical.
 - .2 variation in supporting effect does not exceed 25 % of total load.

3.3 HANGER SPACING

- .1 Plumbing piping: to Canadian Plumbing Code or authority having jurisdiction.
- .2 Fire protection: to applicable fire code.
- .3 Gas and fuel oil piping: up to NPS 1/2: every 1.8 m.
- .4 Copper piping: up to NPS 1/2: every 1.5 m.
- .5 Flexible joint roll groove pipe: in accordance with table below, but not less than one hanger at joints.
- .6 Within 300 mm of each elbow.
- .7 Pipework greater than NPS 12: to MSS SP69.
- .8 Hydronic, steam, steam condensate, compressed air, rigid, and flexible joint roll groove pipe: in accordance with table below, but not less than one hanger at joints.

MAXIMUM HANGER SPACING AND MINIMUM ROD SIZE

O.D		STEEL PIPE				COPPER TUBE		ROD SIZE	
INCHES	mm	WATER		STEAM / AIR		FT	METER	INCH	mm
		FT	METER	FT	METER				
<= 1/2	12.7	7	2.13	8	2.44	5	1.52	1/4'	6.4
3/4'	19.1	7	2.13	9	2.74	5	1.52	1/4'	6.4
1	25.4	7	2.13	9	2.74	6	1.83	1/4'	6.4
1-1/4'	31.7	8	2.44	10	3.05	7	2.13	1/4'	6.4
1-1/2'	38.1	9	2.74	12	3.66	8	2.44	3/8'	9.5
2	50.8	10	3.05	13	3.96	8	2.44	3/8'	9.5
2-1/2'	63.5	11	3.35	14	4.27	9	2.74	3/8'	9.5
3	76.2	12	3.66	15	4.57	10	3.05	3/8'	9.5
4	101.6	14	4.27	17	5.18	12	3.66	1/2'	12.7
6	152.4	17	5.18	21	6.40	14	4.27	1/2'	12.7
8	203.2	19	5.79	24	7.31	16	4.88	5/8'	15.8
10	254.0	20	6.10	26	7.92	18	5.49	3/4'	19.0
12	304.8	23	7.01	30	9.14	19	5.79	7/8'	22.2
14	355.6	25	7.62	32	9.75			1	25.4
16	406.4	27	8.23	35	10.67			1	25.4
18	457.2	28	8.53	37	11.28			1-1/4'	31.7
20	508.0	30	9.14	39	11.89			1-1/4'	31.7

3.4 HANGER INSTALLATION

- .1 Install hanger so that rod is vertical under operating conditions.
- .2 Adjust hangers to equalize load.
- .3 Support from structural members. Where structural bearing does not exist or inserts are not in suitable locations, provide supplementary structural steel members.

3.5 HORIZONTAL MOVEMENT

- .1 Angularity of rod hanger resulting from horizontal movement of pipework from cold to hot position not to exceed 4 degrees from vertical.
- .2 Where horizontal pipe movement is less than 13 mm, offset pipe hanger and support so that rod hanger is vertical in the hot position.

3.6 FINAL ADJUSTMENT

- .1 Adjust hangers and supports:
 - .1 Ensure that rod is vertical under operating conditions.

- .2 Equalize loads.
 - .2 Adjustable clevis:
 - .1 Tighten hanger load nut securely to ensure proper hanger performance.
 - .2 Tighten upper nut after adjustment.
 - .3 C-clamps:
 - .1 Follow manufacturer's recommended written instructions and torque values when tightening C-clamps to bottom flange of beam.
 - .4 Beam clamps:
 - .1 Hammer jaw firmly against underside of beam.
- 3.7 FIELD QUALITY CONTROL (as required)**

END OF SECTION

Part 1 GENERAL

1.1 REFERENCES

- .1 Definitions:
 - .1 For purposes of this section:
 - .1 "CONCEALED" - insulated mechanical services and equipment in suspended ceilings and non-accessible chases and furred-in spaces.
 - .2 "EXPOSED" - means "not concealed" as previously defined.
 - .3 Insulation systems - insulation material, fasteners, jackets, and other accessories.
 - .2 TIAC Codes:
 - .1 CRD: Code Round Ductwork,
 - .2 CRF: Code Rectangular Finish.
- .2 Reference Standards:
 - .1 American Society of Heating, Refrigeration and Air Conditioning Engineers (ASHRAE)
 - .1 ANSI/ASHRAE/IESNA, SI; Energy Standard for Buildings Except Low-Rise Residential Buildings.
 - .2 ASTM International Inc.
 - .1 ASTM B209M, Standard Specification for Aluminum and Aluminum-Alloy Sheet and Plate (Metric).
 - .2 ASTM C335, Standard Test Method for Steady State Heat Transfer Properties of Pipe Insulation.
 - .3 ASTM C411, Standard Test Method for Hot-Surface Performance of High-Temperature Thermal Insulation.
 - .4 ASTM C449/C449M, Standard Specification for Mineral Fiber-Hydraulic-Setting Thermal Insulating and Finishing Cement.
 - .5 ASTM C547, Standard Specification for Mineral Fiber Pipe Insulation.
 - .6 ASTM C553, Standard Specification for Mineral Fiber Blanket Thermal Insulation for Commercial and Industrial Applications.
 - .7 ASTM C612, Standard Specification for Mineral Fiber Block and Board Thermal Insulation.
 - .8 ASTM C795, Standard Specification for Thermal Insulation for Use in Contact with Austenitic Stainless Steel.
 - .9 ASTM C921, Standard Practice for Determining the Properties of Jacketing Materials for Thermal Insulation.
 - .3 Canadian General Standards Board (CGSB)
 - .1 CGSB 51-GP-52Ma, Vapour Barrier, Jacket and Facing Material for Pipe, Duct and Equipment Thermal Insulation.
 - .4 Thermal Insulation Association of Canada (TIAC): National Insulation Standards.
 - .5 Underwriters Laboratories of Canada (ULC)

- .1 CAN/ULC-S102, Method of Test for Surface Burning Characteristics of Building Materials and Assemblies.
- .2 CAN/ULC-S701, Standard for Thermal Insulation, Polystyrene, Boards and Pipe Covering.

1.2 ACTION AND INFORMATIONAL SUBMITTALS

- .1 Product Data:
 - .1 Submit manufacturer's product literature for all equipment and material provided in electronic format (PDF) to NRC for review.
 - .2 Submit Workplace Hazardous Materials Information System (WHMIS) Material Safety Data Sheets (MSDS). Indicate VOC's for adhesive and solvents during application and curing.
 - .3 Provide:
 - .1 Manufacture's written duct insulation jointing recommendations and special handling criteria, installation sequence, cleaning procedures.
 - .2 Manufacturer's printed product literature and datasheets for duct insulation, and include product characteristics, performance criteria, physical size, finish and limitations.
- .2 Samples: When requested
 - .1 Submit for approval: complete assembly of each type of insulation system, insulation, coating, and adhesive proposed.
 - .2 Mount sample on 12 mm plywood board.
 - .3 Affix typewritten label beneath sample indicating service.
- .3 Closeout Submittals
 - .1 Provide maintenance data for incorporation into manual.

Part 2 Products

2.1 FIRE AND SMOKE RATING

- .1 To CAN/ULC-S102:
 - .1 Maximum flame spread rating: 25.
 - .2 Maximum smoke developed rating: 50.

2.2 INSULATION

- .1 Mineral fibre: as specified includes glass fibre, rock wool, slag wool.
- .2 Thermal conductivity ("k" factor) not to exceed specified values at 24 degrees C mean temperature when tested in accordance with ASTM C335.
- .3 TIAC Code C-1: Rigid mineral fibre board to ASTM C612, with factory applied vapour retarder jacket to CGSB 51-GP-52Ma (as scheduled in PART 3 of this Section).

- .4 TIAC Code C-2: Mineral fibre blanket to ASTM C553 faced with factory applied vapour retarder jacket to CGSB 51-GP-52Ma (as scheduled in PART 3 of this section).
 - .1 Mineral fibre: to ASTM C553.
 - .2 Jacket: to CGSB 51-GP-52Ma.
 - .3 Maximum "k" factor: to ASTM C553.

2.3 JACKETS

- .1 Canvas:
 - .1 220 gm/m² cotton, plain weave, treated with dilute fire retardant lagging adhesive to ASTM C921.
- .2 Lagging adhesive: compatible with insulation.
 - .1 Maximum VOC limit 50 g/L to SCAQMD Rule 1168.
- .3 Aluminum:
 - .1 To ASTM B209 with moisture barrier as scheduled in PART 3 of this section.
 - .2 Thickness: 0.50 mm sheet.
 - .3 Finish: Smooth.
 - .4 Jacket banding and mechanical seals: 19 mm wide, 0.5 mm thick stainless steel.
- .4 Stainless steel:
 - .1 Type: 304 (typical), 316 (when indicated).
 - .2 Thickness: 0.25 mm sheet.
 - .3 Finish: Corrugated or Stucco embossed.
 - .4 Jacket banding and mechanical seals: 12 mm wide, 0.5 mm thick stainless steel.
- .5 Self-Adhering Multi-ply aluminum:
 - .1 Material Thickness: 7 mils
 - .2 Service Temperature: -40 to 149C
 - .3 Surface: Stucco Embossed
 - .4 UV-Resistant aluminum weathering surface.
 - .5 Standard of acceptance: Venture Clad: 1577CW-E.

2.4 ACCESSORIES

- .1 Vapour retarder lap adhesive:
 - .1 Water based, fire retardant type, compatible with insulation.
- .2 Indoor Vapour Retarder Finish:
 - .1 Vinyl emulsion type acrylic, compatible with insulation.
- .3 Insulating Cement: hydraulic setting on mineral wool, to ASTM C449.
- .4 ULC Listed Canvas Jacket:

- .1 220 gm/m² cotton, plain weave, treated with dilute fire retardant lagging adhesive to ASTM C921.
- .5 Outdoor Vapour Retarder Mastic:
 - .1 Vinyl emulsion type acrylic, compatible with insulation.
 - .2 Reinforcing fabric: Fibrous glass, untreated 305 g/m².
- .6 Tape: self-adhesive, aluminum reinforced, 75 mm wide minimum.
- .7 Contact adhesive: quick-setting
- .8 Canvas adhesive: washable.
- .9 Tie wire: 1.5 mm stainless steel.
- .10 Banding: 12 mm wide, 0.5 mm thick stainless steel.
- .11 Facing: 25 mm galvanized steel hexagonal wire mesh stitched on one face of insulation.
- .12 Fasteners: 2 mm diameter pins with 35 mm diameter square or round clips, length to suit thickness of insulation.

Part 3 EXECUTION

3.1 APPLICATION

- .1 Manufacturer's Instructions: comply with manufacturer's written recommendations, including product technical bulletins, handling, storage and installation instructions, and datasheets.

3.2 PRE-INSTALLATION REQUIREMENTS

- .1 Pressure test ductwork systems complete, witness and certify.
- .2 Ensure surfaces are clean, dry, free from foreign material.

3.3 INSTALLATION

- .1 Install in accordance with TIAC National Standards.
- .2 Apply materials in accordance with manufacturers instructions and as indicated.
- .3 Use 2 layers with staggered joints when required nominal thickness exceeds 50 mm.
- .4 Maintain uninterrupted continuity and integrity of vapour retarder jacket and finishes.
 - .1 Ensure hangers, and supports are outside vapour retarder jacket.
- .5 Hangers and supports in accordance with Section 23 05 29 - Hangers and Supports for HVAC Piping and Equipment.
 - .1 Apply high compressive strength insulation where insulation may be compressed by weight of ductwork.

- .6 Fasteners: install at 300 mm on centre in horizontal and vertical directions, minimum 2 rows each side.

3.4 DUCTWORK INSULATION SCHEDULE

- .1 Insulation types and thicknesses: conform to following table:

	TIAC Code	Vapour Retarder	Thickness (mm)
Rectangular cold and dual temperature supply air ducts	C-1	Yes	50
Round cold and dual temperature supply air ducts	C-2	Yes	50
Rectangular warm air ducts	C-1	No	25
Round warm air ducts	C-1	No	25
Supply, return and exhaust ducts exposed in space being served			none
Outside air ducts to mixing plenum	C-1	Yes	25
Mixing plenums	C-1	Yes	25
Exhaust duct between dampers and louvres	C-1	No	25
Rectangular ducts outside	C-1	Special	50
Round ducts outside	C-1	Special	50
Acoustically lined ducts	None		

- .2 Exposed round ducts 600 mm and larger, smaller sizes where subject to abuse:

- .1 Use TIAC code C-1 insulation, scored to suit diameter of duct.

- .3 Insulation jacket: conform to following table:

	TIAC Code	
Indoor	Rectangular none	Round none
Exterior	CRF/5	CRD/5

END OF SECTION

Part 1 General

1.1 SECTION INCLUDES

- .1 Piping and valve selection for campus steam and condensate system up to 103 kPa.

1.2 REFERENCES

- .1 American National Standards Institute (ANSI) / American Society of Mechanical Engineers (ASME)
 - .1 ASME B16.1, Cast Iron Pipe Flanges and Flanged Fittings: Class 25, 125, 250 and 800.
 - .2 ASME B16.25, Buttwelding Ends.
 - .3 ASME B16.3, Malleable Iron Threaded Fittings: Classes 150 and 300.
 - .4 ANSI/ASME B16.5, Pipe Flanges and Flanged Fittings: NPS 1/2 through 24.
 - .5 ANSI/ASME B16.9, Factory-Made Wrought Steel Buttwelding Fittings.
 - .6 ANSI B18.2.1, Square and Hex Bolts and Screws (Inch Series).
 - .7 ANSI/ASME B18.2.2, Square and Hex Nuts (Inch Series).
- .2 American National Standards Institute (ANSI) / American Water Works Association (AWWA)
 - .1 ANSI/AWWA C111/A21.11, Rubber-Gasket Joints for Ductile-Iron Pressure Pipe and Fittings.
- .3 ASTM International Inc.
 - .1 ASTM A47/A47M, Standard Specification for Ferritic Malleable Iron Castings.
 - .2 ASTM A53/A53M, Standard Specification for Pipe, Steel, Black and Hot-Dipped, Zinc Coated, Welded and Seamless.
 - .3 ASTM A126, Standard Specification for Gray Iron Castings for Valves, Flanges, and Pipe Fittings.
- .4 Canadian Standards Association (CSA International)
 - .1 CSA W48, Filler Metals and Allied Materials for Metal Arc Welding.
- .5 Manufacturers Standardization Society of the Valve and Fittings Industry, Inc.
 - .1 MSS-SP-70, Cast Iron Gate Valves, Flanged and Threaded Ends.
 - .2 MSS-SP-71, Gray Iron Swing Check Valves, Flanged and Threaded Ends.
 - .3 MSS-SP-80, Bronze Gate, Globe, Angle and Check Valves.
 - .4 MSS-SP-85, Cast Iron Globe and Angle Valves, Flanged and Threaded Ends.

1.3 ACTION AND INFORMATIONAL SUBMITTALS

- .1 Provide submittals in accordance with Section 01000
- .2 Product Data:

- .1 Provide manufacturer's printed product literature and datasheets for valves and pipes and include product characteristics, performance criteria, physical size, finish and limitations.

.3 Shop Drawings:

- .1 Provide shop drawing for all valves and fittings c/w mill test report for all piping.

1.4 DELIVERY, STORAGE AND HANDLING

- .1 See Section 01000

1.5 MAINTENANCE MATERIALS SUBMITTALS

.1 Extra Stock Materials:

- .1 Provide spare parts as follows:
 - .1 Valve seats: one for every ten valves, each size. Minimum one.
 - .2 Discs: one for every ten valves, each size. Minimum one.
 - .3 Stem packing: one for every ten valves, each size. Minimum one.
 - .4 Valve handles: 2 of each size.
 - .5 Gaskets for flanges: one for every ten flanges.

Part 2 Products

2.1 PIPE

- .1 Steel pipe: Material – Carbon Steel – ASME A53 Gr B- seamless, ASME B31.1
 - .1 Steam: Schedule 40
 - .2 Condensate: Schedule 80.

2.2 PIPE JOINTS

- .1 NPS 2 and under: screwed fittings with PTFE tape.
- .2 NPS 2-1/2 and over: welding fittings and flanges to CSA W48.
- .3 Flanges: raised face or plain. Flange gaskets to ASME B16.5
- .4 Pipe thread: taper.
- .5 Bolts and nuts: High Strength Alloy Steel: ASME A193 GR B7, ASME B18.2.1, ASME B18.2.2.
- .6 Buttwelding ends: ASME B16.25

2.3 FLANGES AND FITTINGS

- .1 Screwed fittings: malleable iron to ASME B16.3
- .2 Steel pipe gaskets, flanges and flanged fittings: to ANSI/ASME B16.5.
- .3 Buttwelding fittings: steel to ANSI/ASME B16.9.
- .4 Unions: malleable iron, to ASME B16.3.
- .5 Steam pressure
 - .1 Less than and equal to 15 psig (690 kPa): Class 150
 - .2 Above 15 psig (690 kPa): Class 300

2.4 VALVES

.2

Part 3 Execution

3.1 APPLICATION

- .1 Manufacturer's Instructions: comply with manufacturer's written recommendations, including product technical bulletins, handling, storage and installation instructions, and datasheets.
- .2 All equipment and material to be installed as per manufacturer instruction and as per good industry practices.

3.2 PIPING

- .1 Pipework to be installed as per good standard and practices.
- .2 Connect branch lines into top of mains.
- .3 Install piping in direction of flow with slopes as follows, unless indicated:
 - .1 Steam: 1:240.
 - .2 Condensate return: 1:70
- .4 Make provision for thermal expansion as indicated
- .5 Drip pocket: line size.

3.3 VALVES

- .1 Gate: unless otherwise stated.
- .2 Globe:
 - .1 All bypass connections
 - .2 Drain connection
 - .3 At condensate traps
 - .4 Condensate tank drain

3.4 TESTING

- .1 Certification and qualifications requirements:
 - .1 Certificate of authorization from Technical Standard and Safety Association of Ontario (TSSA) to undertake work on process piping B31.1.
 - .2 Submit welding procedure for all welding types.
 - .3 Provide copy of a valid welding qualification record for all employees that will complete welding
 - 2. Provide mill test report for all piping.
 - 3. The contractor is responsible to organize and arrange for all license and welding procedure and welders qualification verification by TSSA inspector. This shall also include TSSA
-

inspector visits for inspections and to witness testing and non-destructive examination and visit fees required by TSSA.

4. Contractor shall bare all costs associated with any modification necessary to meet the requirements of tssa.
5. Contractor shall be responsible for provision of all labour and material necessary to blank off tested section, and remove items which cannot sustain test pressure,
6. After hydrostatic test, contractor shall ensure that all new piping sections are thoroughly dried off and cleaned from any debris before being put in service. Contractor shall bear all costs associated with radiography testing. Contractor shall provide NRC with an independent report detailing evaluation of radiography results for a minimal of 20% of randomly selected welds (by NRC or TSSA). Radiography report shall be completed by individual certified to CAN-CGSB-48.9712 and shall include radiography images.
7. All welds not having a radiography test shall be tested with liquids penetrate.
8. All welds to existing piping to be have a radiography inspection.
9. Contractor shall provide records of the tests, data on instrumentation used and calibration of gauges shall be made available to NRC.
10. All piping components supplied must have a valid Canadian Registration Number (CRN) recognized by the TSSA. All CRN(s) to be supplied and approved by NRC prior to installation. Contractor shall coordinate with the TSSA inspector time of welding. TSSA inspector shall be able to witness and inspected the first weld pass and piping fit-up (first five welds minimum).

3.5 SYSTEM START-UP

- .1 Prior to ant start-up, contractor shall insure that NRC is advised and have written confirmation from NRC that startup of steam/condensate system is approved.
- .2 To be coordinated with NRC. See section 01000.

3.6 PERFORMANCE VERIFICATION (PV)

- .1 It is the contractors responsibility to verify and proved to NRC that all equipment and materials to manufacturers specifications.

3.7 CLEANING

- .1 See section 01000.

END OF SECTION

Part 1 General

1.1 REFERENCES

- .1 American Society of Mechanical Engineers (ASME)
 - .1 ASME B16.22, Wrought Copper and Copper Alloy Solder - Joint Pressure Fittings.
 - .2 ASME B16.24, Cast Copper Pipe Flanges and Flanged Fittings: Class 150.
 - .3 ASME B16.26, Cast Copper Alloy Fittings for Flared Copper Tubes.
- .2 American Society for Testing and Materials International (ASTM)
 - .1 ASTM A307, Standard Specification for Carbon Steel Bolts and Studs, 60,000 PSI Tensile Strength.
 - .2 ASTM B280, Standard Specification for Seamless Copper Tube for Air Conditioning and Refrigeration Field Service.
- .3 Health Canada / Workplace Hazardous Materials Information System (WHMIS)
 - .1 Material Safety Data Sheets (MSDS).

1.2 SUBMITTALS

- .1 Product Data:
 - .1 Submit manufacturer's product literature in electronic format (PDF) to NRC for review.
 - .2 Submit Workplace Hazardous Materials Information System (WHMIS) Material Safety Data Sheets (MSDS). Indicate VOC's for adhesive and solvents during application and curing.
 - .3 Indicate the following: Flexible connections, Duct access doors, Turning vanes and Instrument test ports.
- .2 Closeout Submittals
 - .1 Provide maintenance data for incorporation into manual.

Part 2 Products

2.1 TUBING

- .1 See drawings.

2.2 FITTINGS

- .1 Wrought copper and copper alloy, solder type: to ANSI/ASME B16.22. Cast bronze threaded fittings, Class 150: to ANSI/ASME B16.15.
- .3 Bronze pipe flanges and flanged fittings, Class 150 to ANSI/ASME B16.24.
- .4 To be degreased for oxygen service.

2.3 BRAZED JOINTS

- .1 Brazed: See drawing

2.4 CHECK VALVES:

- .1 Swing Check Valve: NPS 2 and under, Class 150, screwed
 - .1 To MSS SP-80 and ANSI B1.20.1.
 - .2 Body: Y-pattern with integral seat at 45 degrees, screw-in cap with hex head.
 - .3 Disc and seat: renewable rotating disc, two-piece hinge disc construction; seat: Standard of acceptance: KITZ #29, degreased for oxygen service.

2.5 VALVES

- .1 See drawings

Part 3 Execution

3.1 MANUFACTURER'S INSTRUCTIONS

- .1 Compliance: comply with manufacturer's written recommendations or specifications, including product technical bulletins, handling, storage and installation instructions, and datasheet.

3.2 VALVES:

- .1 Install where indicated on drawing and in specifications
- .2 Install at all low points when piping is tested with water.
- .3 Install as per manufacturer's recommendations.

3.3 BRAZING PROCEDURES

- .1 Bleed inert gas (nitrogen) into pipe during brazing.
- .2 Valves are not to be brazed.
- .3 Remove valve internal parts, solenoid valve coils, sight glass.

3.4 PIPING INSTALLATION

- .1 General:
 - .1 Hard drawn copper tubing: do not bend. Minimize use of fittings.
 - .2 Contractor shall provide test ports for pressure testing as required.

3.5 PRESSURE AND LEAK TESTING

- .1 Close valves and other equipment not designed for test pressures.
- 2. Provide mill test report for all piping.
- 3. The contractor is responsible to organize and arrange for all license and welding procedure and welders qualification verification.

5. Contractor shall be responsible for provision of all labour and material necessary to blank off tested section, and remove items which cannot sustain test pressure. All test procedures to be by ASME 31.1.
6. After hydrostatic test at a minimum pressure of 1.5 times design pressure for 30 minutes, contractor shall ensure that all new piping sections are thoroughly dried off and cleaned from any debris before being put in service.
7. Contractor may perform a pneumatic test at a minimum pressure of 1.2 times design pressure for 30 minutes instead of hydrostatic pending NRC approval.
8. NRC shall be given a minimum of 48 hour notice of all tests.
9. Contractor shall provide records of the tests, data on instrumentation used and calibration of gauges shall be made available to NRC. Range on pressure gauge used for testing shall not exceed 1.25 times test pressure.
10. All piping components provided must have a valid Canadian Registration Number (CRN) recognized by the TSSA. All CRN(s) to be supplied and approved by NRC prior to installation.

3.6 CLEANING

- .1 Upon completion and verification of performance of installation, remove surplus materials, excess materials, rubbish, tools and equipment.

END OF SECTION

Part 1 GENERAL

1.1 SUMMARY

- .1 Section Includes:
 - .1 Materials and installation for duct accessories including flexible connections, access doors, vanes and collars.

1.2 REFERENCES

- .1 Health Canada/Workplace Hazardous Materials Information System (WHMIS).
 - .1 Material Safety Data Sheets (MSDS).
- .2 Sheet Metal and Air Conditioning Contractors' National Association (SMACNA).
 - .1 SMACNA - HVAC Duct Construction Standards - Metal and Flexible, [95].

1.3 SUBMITTALS

- .1 Product Data:
 - .1 Submit manufacturer's product literature in electronic format (PDF) to NRC for review.
 - .2 Submit Workplace Hazardous Materials Information System (WHMIS) Material Safety Data Sheets (MSDS). Indicate VOC's for adhesive and solvents during application and curing.
 - .3 Indicate the following: Flexible connections, Duct access doors, Turning vanes and Instrument test ports.
- .2 Closeout Submittals
 - .1 Provide maintenance data for incorporation into manual.
- .3 Test Reports: submit certified test reports from approved independent testing laboratories indicating compliance with specifications for specified performance characteristics and physical properties.
 - .1 Certification of ratings: catalogue or published ratings to be those obtained from tests carried out by manufacturer or independent testing agency signifying adherence to codes and standards.
- .4 Certificates: submit certificates signed by manufacturer certifying that materials comply with specified performance characteristics and physical properties.
- .5 Instructions: submit manufacturer's installation instructions.
- .6 Manufacturer's Field Reports: manufacturer's field reports specified.

Part 2 PRODUCTS

2.1 GENERAL

- .1 Manufacture in accordance with SMACNA - HVAC Duct Construction Standards.

2.2 FLEXIBLE CONNECTIONS

- .1 Frame: galvanized sheet metal frame 0.66 mm thick with fabric clenched by means of double locked seams.
- .2 Material:
 - .1 Fire resistant, self extinguishing, neoprene coated glass fabric, temperature rated at minus 40 to 90degrees C, density of 1.3 kg/m².

2.3 ACCESS DOORS IN DUCTS

- .1 Non-Insulated Ducts: sandwich construction of same material as duct, one sheet metal thickness heavier, minimum 0.6 mm thick complete with sheet metal angle frame.
- .2 Insulated Ducts: sandwich construction of same material as duct, one sheet metal thickness heavier, minimum 0.6 mm thick complete with sheet metal angle frame and 25 mm thick rigid glass fibre insulation.
- .3 Gaskets: neoprene.
- .4 Hardware:
 - .1 Up to 300 x 300 mm: two sash locks complete with safety chain.
 - .2 301 to 450 mm: four sash locks complete with safety chain.
 - .3 451 to 1000 mm: piano hinge and minimum two sash locks.
 - .4 Doors over 1000 mm: piano hinge and two handles operable from both sides.
 - .5 Hold open devices.
 - .6 300 x 300 mm glass viewing panels where indicated.

2.4 TURNING VANES

- .1 Factory or shop fabricated double thickness with trailing edge, to recommendations of SMACNA and as indicated.

2.5 INSTRUMENT TEST

- .1 1.6 mm thick steel zinc plated after manufacture.
- .2 Cam lock handles with neoprene expansion plug and handle chain.
- .3 28 mm minimum inside diameter. Length to suit insulation thickness.
- .4 Neoprene mounting gasket.

2.6 SPIN-IN COLLARS

- .1 Conical galvanized sheet metal spin-in collars with lockable butterfly damper.

- .2 Sheet metal thickness to co-responding round duct standards.

Part 3 EXECUTION

3.1 MANUFACTURER'S INSTRUCTIONS

- .1 Compliance: comply with manufacturer's written recommendations or specifications, including product technical bulletins, handling, storage and installation instructions, and data sheet.

3.2 INSTALLATION

- .1 Flexible Connections:
 - .1 Install in following locations:
 - .1 Inlets and outlets to supply air units and fans.
 - .2 Inlets and outlets of exhaust and return air fans.
 - .3 As indicated.
 - .2 Length of connection: 100 mm.
 - .3 Minimum distance between metal parts when system in operation: 75 mm.
 - .4 Install in accordance with recommendations of SMACNA.
 - .5 When fan is running:
 - .1 Ducting on sides of flexible connection to be in alignment.
 - .2 Ensure slack material in flexible connection.
- .2 Access Doors and Viewing Panels:
 - .1 Size:
 - .1 600 x 600 mm for person size entry.
 - .2 450 x 450 mm for servicing entry.
 - .3 300 x 300 mm for viewing.
 - .4 As indicated.
 - .2 Locations:
 - .1 Fire and smoke dampers.
 - .2 Control dampers.
 - .3 Devices requiring maintenance.
 - .4 Required by code.
 - .5 Reheat coils.
 - .6 Elsewhere as indicated.
- .3 Instrument Test Ports:
 - .1 General:
 - .1 Install in accordance with recommendations of SMACNA and in accordance with manufacturer's instructions.
 - .2 Locate to permit easy manipulation of instruments.
 - .3 Install insulation port extensions as required.

- .4 Locations:
 - .1 For traverse readings:
 - .1 Ducted inlets to roof and wall exhausters.
 - .2 Inlets and outlets of other fan systems.
 - .3 Main and sub-main ducts.
 - .4 And as indicated.
 - .2 For temperature readings:
 - .1 At outside air intakes.
 - .2 In mixed air applications in locations as approved by Engineer.
 - .3 At inlet and outlet of coils.
 - .4 Downstream of junctions of two converging air streams of different temperatures.
 - .5 And as indicated.
- .4 Turning vanes:
 - .1 Install in accordance with recommendations of SMACNA and as indicated.

END OF SECTION

Part 1 General

1.1 SUMMARY

.1 Section Includes:

- .1 Materials and installation of low-pressure metallic ductwork, joints and accessories.

1.2 REFERENCES

- .1 American Society of Heating, Refrigerating and Air-Conditioning Engineers, Inc. (ASHRAE).
- .2 American Society for Testing and Materials International, (ASTM).
 - .1 ASTM A480/A480M, Standard Specification for General Requirements for Flat-Rolled Stainless and Heat-Resisting Steel Plate, Sheet and Strip.
 - .2 ASTM A635/A635M, Standard Specification for Steel, Sheet and Strip, Heavy-Thickness Coils, Carbon, Hot Rolled.
 - .3 ASTM A653/A653M, Standard Specification for Steel Sheet, Zinc Coated (Galvanized) or Zinc-Iron Alloy Coated (Galvannealed) by the Hot-Dip Process.
- .3 Department of Justice Canada (Jus).
 - .1 Canadian Environmental Protection Act (CEPA).
- .4 Health Canada/Workplace Hazardous Materials Information System (WHMIS).
 - .1 Material Safety Data Sheets (MSDS).
- .5 National Fire Protection Association (NFPA).
 - .1 NFPA 90A, Standard for the Installation of Air-Conditioning and Ventilating Systems.
 - .2 NFPA 90B, Standard for the Installation of Warm Air Heating and Air-Conditioning Systems.
 - .3 NFPA 96, Standard for Ventilation Control and Fire Protection of Commercial Cooking Operations.
- .6 Sheet Metal and Air Conditioning Contractors' National Association (SMACNA).
 - .1 SMACNA HVAC Duct Construction Standards - Metal and Flexible, 2nd Edition and Addendum No. 1.
 - .2 SMACNA HVAC Air Duct Leakage Test Manual, Latest Edition.
 - .3 IAQ Guideline for Occupied Buildings Under Construction, Latest Edition.
- .7 Transport Canada (TC).
 - .1 Transportation of Dangerous Goods Act (TDGA), 1992, c. 34.

1.3 SUBMITTALS

- .1 Submit shop drawings to NRC for review.
- .2 Product Data: submit WHMIS MSDS - Material Safety Data for the following:

- .1 Sealants.
- .2 Tape.
- .3 Proprietary Joints.

Part 2 Products

2.1 SEAL CLASSIFICATION

- .1 Classification as follows:

Maximum Pressure Pa	SMACNA Seal Class
500	C
250	C
125	C

- .2 Seal classification:

- .1 Class A: longitudinal seams, transverse joints, duct wall penetrations and connections made airtight with sealant and tape.
- .2 Class B: longitudinal seams, transverse joints and connections made airtight with sealant and/or tape or combination thereof.
- .3 Class C: transverse joints and connections made air tight with gaskets, sealant, tape or combination thereof. Longitudinal seams unsealed.

2.2 SEALANT

- .1 Sealant: oil resistant, polymer type flame resistant duct sealant. Temperature range of minus 30°C to plus 93°C.

2.3 TAPE

- .1 Tape: polyvinyl treated, open weave fiberglass tape, 50 mm wide.

2.4 DUCT LEAKAGE

- .1 In accordance with SMACNA HVAC Air Duct Leakage Test Manual.

2.5 FITTINGS

- .1 Fabrication: to SMACNA.
- .2 Radiused elbows:
 - .1 Rectangular: Centreline radius: 1.5 times width of duct.
 - .2 Round: smooth radius or five piece. Centreline radius: 1.5 times diameter.
- .3 Mitred elbows, rectangular:
 - .1 To 400 mm: with single thickness turning vanes.
 - .2 Over 400 mm: with double thickness turning vanes.
- .4 Branches:

- .1 Rectangular main and branch: with radius on branch 1.5 times width of duct or 45° entry on branch.
- .2 Round main and branch: enter main duct at 45° with conical connection.
- .3 Provide volume control damper in branch duct near connection to main duct.
- .4 Main duct branches: with volume control damper.
- .5 Transitions:
 - .1 Diverging: 20° maximum included angle.
 - .2 Converging: 30° maximum included angle.
- .6 Offsets:
 - .1 Full short radius elbows as indicated.
- .7 Obstruction deflectors: maintain full cross-sectional area. Maximum included angles: as for transitions.

2.6 FIRE STOPPING

- .1 Retaining angles around duct, on both sides of fire separation.
- .2 Fire stopping material and installation must not distort duct.

2.7 GALVANIZED STEEL

- .1 Lock forming quality: to ASTM A653, G90 zinc coating.
- .2 Thickness, fabrication and reinforcement: to SMACNA.
- .3 Joints: to SMACNA or proprietary manufactured duct joint. Proprietary manufactured flanged duct joint to be considered to be a class A seal.

2.8 HANGERS AND SUPPORTS

- .1 Strap hangers: of same material as duct but next sheet metal thickness heavier than duct. Maximum size duct supported by strap hanger: 500 mm.
- .2 Hanger configuration: to SMACNA.
- .3 Hangers: galvanized steel angle with black steel rods to ASHRAE or SMACNA following table:

Duct Size (mm)	Angle Size (mm)	Rod Size (mm)
up to 750	25x25x3	6
751 to 1050	40x40x3	6
1051 to 1500	40x40x3	10
1501 to 2100	50x50x3	10
2101 to 2400	50x50x5	10
2401 and over	50 x 50 x 6	10

- .4 Upper hanger attachments:
 - .1 For concrete: manufactured concrete inserts.
 - .1 Acceptable Product: Myatt, Grinnell, Hunt.

- .2 For steel joist: manufactured joist clamp steel plate washer.
 - .1 Acceptable Product: Myatt, Grinnell, Hunt.
- .3 For steel beams: manufactured beam clamps:
 - .1 Acceptable Product: Myatt, Grinnell, Hunt.

Part 3 Execution

3.1 GENERAL

- .1 Do work in accordance with NFPA 90A, NFPA 90B, and SMACNA.
- .2 Do not break continuity of insulation vapour barrier with hangers or rods. Insulate strap hangers 100 mm beyond insulated duct.
- .3 Support risers in accordance with SMACNA.
- .4 Install breakaway joints in ductwork on sides of fire separation. Do not place fire stopping material in expansion space between damper sleeve and fire partition.
- .5 Install proprietary manufactured flanged duct joints in accordance with manufacturer's instructions.
- .6 Manufacture duct in lengths and diameter to accommodate installation of acoustic duct lining.

3.2 HANGERS

- .1 Strap hangers: install in accordance with SMACNA.
- .2 Angle hangers: complete with locking nuts and washers.
- .3 Hanger spacing: in accordance with SMACNA or as follows:

Duct Size (mm)	Spacing (mm)
to 1500	3000
1501 and over	2500

3.3 Watertight Duct

3.4 WATERTIGHT DUCT

- .1 Provide watertight duct for:
 - .1 Dishwasher exhaust.
 - .2 Fresh air intake.
 - .3 Minimum 3000 mm from duct mounted humidifier in all directions.
 - .4 As indicated.
- .2 Form bottom of horizontal duct without longitudinal seams. Solder or weld joints of bottom and side sheets. Seal other joints with duct sealer.
- .3 Slope horizontal branch ductwork down towards fume hoods served. Slope header ducts down toward risers.

- .4 Fit base of riser with 150 mm deep drain sump and 32mm drain connected, with deep seal trap and valve and discharging to open funnel drain or service sink or as approved by Departmental Representative.

3.5 SEALING AND TAPING

- .1 Apply sealant to outside of joint to manufacturer's recommendations.
- .2 Bed tape in sealant and recoat with minimum of one coat of sealant to manufacturers recommendations.

3.6 LEAKAGE TESTS

- .1 In accordance with SMACNA HVAC Duct Leakage Test Manual.
- .2 Do leakage tests in sections.
- .3 Make trial leakage tests as instructed to demonstrate workmanship.
- .4 Install no additional ductwork until trial test has been passed.
- .5 Test section minimum of 30 m long with not less than three branch takeoffs and two 90° elbows.
- .6 Complete test before insulation or concealment.

END OF SECTION

Part 1 GENERAL

1.1 SUMMARY

- .1 Section Includes:
 - .1 Operating dampers for mechanical forced air ventilation and air conditioning systems.

1.2 REFERENCES

- .1 American Society for Testing and Materials International (ASTM)
 - .1 ASTM A653/A653M, Standard Specification for Steel Sheet, Zinc-Coated (Galvanized) or Zinc-Iron Alloy-Coated (Galvannealed) by Hot-Dip Process.
- .2 Health Canada/Workplace Hazardous Materials Information System (WHMIS)
 - .1 Material Safety Data Sheets (MSDS).

1.3 SUBMITTALS

- .1 Product Data:
 - .1 Submit manufacturer's product literature in electronic format (PDF) to NRC for review.
 - .2 Include product characteristics, performance criteria, limitations and Workplace Hazardous Materials Information System (WHMIS) Material Safety Data Sheets
 - .3 Indicate the following:
 - .1 Performance data.
- .2 Closeout Submittals
 - .1 Provide maintenance data for incorporation into manual.

1.4 DELIVERY, STORAGE, AND HANDLING

- .1 Packing, shipping, handling and unloading:
 - .1 Deliver, store and handle materials in accordance with manufacturer's written instructions.

Part 2 PRODUCTS

2.1 MULTI-LEAF DAMPERS

- .1 Opposed and/or parallel blade type as indicated.
- .2 Extruded aluminum, interlocking blades, complete with extruded vinyl seals, spring stainless steel side seals, extruded aluminum frame.
- .3 Pressure fit self-lubricated bronze bearings.

- .4 Linkage: plated steel tie rods, brass pivots and plated steel brackets, complete with plated steel control rod.
- .5 Operator: Sized by manufacturer to suit damper
 - .1 Damper Actuator:
 - .1 Power : 120V
 - .2 Control: 4 to 20 mA / 0 to 10 Vdc
- .6 Performance:
 - .1 Leakage: in closed position less than 2% of rated air flow at 500 Pa differential across damper.
 - .2 Pressure drop: at full open position less than 25 Pa differential across damper at 10 m/s.
- .7 Insulated aluminum dampers:
 - .1 Frames: insulated with extruded polystyrene foam with RSI 0.88.
 - .2 Blades: constructed from aluminum extrusions with internal hollows insulated with polyurethane or polystyrene foam, RSI 0.88.

Part 3 EXECUTION

3.1 MANUFACTURER'S INSTRUCTIONS

- .1 Compliance: comply with manufacturer's written recommendations or specifications, including product technical bulletins, handling, storage and installation instructions, and datasheet.

3.2 INSTALLATION

- .1 Install where indicated.
- .2 Install in accordance with recommendations of SMACNA and manufacturer's instructions.
- .3 Seal multiple damper modules with silicon sealant.
- .4 Install access door adjacent to each damper. See Section 23 33 00 - Air Duct Accessories.
- .5 Ensure dampers are observable and accessible.

END OF SECTION

1 REFERENCES

- .1 Perform all work to meet or exceed the requirements of the Canadian Electrical Code, CSA Standard C22.1 - (latest edition).
- .2 Consider CSA Electrical Bulletins in force at time of tender submission, while not identified and specified by number in this Division, to be forming part of related CSA Part II standard.
- .3 Where requirements of this specification exceed those of above mentioned standards, this specification shall govern.
- .4 Notify the NRC Departmental Representative as soon as possible when requested to connect equipment supplied by NRC which is not CSA approved..
- .5 Refer to Sections 00 10 00 & 00 15 45

2 PERMITS AND FEES

- .1 Submit to Electrical Inspection Department and Supply Authority necessary number of drawings and specifications for examination and approval prior to commencement of work.
- .2 Pay all fees required for the performance of the work.

3 START-UP

- .1 Instruct the NRC Departmental Representative and operating personnel in the operation, care and maintenance of equipment supplied under this contract.

4 INSPECTION AND FEES

- .1 Furnish a Certificate of Acceptance from the Authorized Electrical Inspection Department on completion of work.
- .2 Request and obtain Special Inspection approval from the Authorized Electrical Inspection Department for any non-CSA approved control panels or other equipment fabricated by the contractor as part of this contract.
- .3 Pay all fees required for inspections.

5 FINISHES

- .1 Shop finish metal enclosure surfaces by removal of rust and scale, cleaning, application of rust resistant primer inside and outside, and at least two coats of finish enamel.
 - .1 Outdoor electrical equipment "equipment green" finish to EEMAC Y1-1-1955.
 - .2 Indoor switchgear and distribution enclosures light grey to EEMAC 2Y-1-1958.
- .2 Clean and touch up surfaces of shop-painted equipment scratched or marred during shipment or installation, to match original paint.

6 EQUIPMENT IDENTIFICATION

- .1 Identify with 3mm (1/8") Brother, P-Touch non-smearing tape, or an alternate approved by the NRC Departmental Representative, all electrical outlets shown on drawings and/or mentioned in the specifications. Indicate only the source of power (Ex. for a receptacle fed from panel L32 circuit #1: "L32-1").
- .2 Identify with lamicoïd nameplates all electrical equipment shown on the drawings and/or mentioned in the specification such as fused switches, isolation switches, motor starting switches, starters, panelboards, industrial type receptacles, junction boxes, etc., regardless of whether or not the electrical equipment was furnished under this section of the specification.
- .3 Coordinate names of equipment and systems with other Divisions to ensure that names and numbers match.
- .4 Wording on lamicoïd nameplates to be approved by the NRC Departmental Representative prior to fabrication.
- .5 Provide two sets of lamicoïd nameplates for each piece of equipment; one in English and one in French.
- .6 Lamicoïd nameplates shall identify the equipment, the voltage characteristics and the power source for the equipment. Example: A new 120/240 volt single phase circuit breaker panelboard, L16, is fed from panelboard LD1 circuit 10.

"PANEL L16
120/240 V
FED FROM LD1-10"

PANNEAU L16
120/240 V
ALIMENTE PAR LD1-10
- .7 Provide warning labels for equipment fed from two or more sources - "DANGER MULTIPLE POWER FEED" black letters on a yellow background. These labels are available from NRC's Facilities Maintenance group in building M-19.
- .8 Lamicoïd nameplates shall be rigid lamicoïd, minimum 1.5 mm (1/16") thick with:
 - .1 Black letters engraved on a white background for normal power circuits.
- .9 For all interior lamicoïd nameplates, mount nameplates using two-sided tape.
- .10 For all exterior lamicoïd nameplates, mount nameplates using self-tapping 2.3 mm (3/32") dia. slot head screws - two per nameplate for nameplates under 75 mm (3") in height and a minimum of 4 for larger nameplates. Holes in lamicoïd nameplates to be 3.7 mm (3/16") diameter to allow for expansion of lamicoïd due to exterior conditions.
 - .1 No drilling is to be done on live equipment.
 - .2 Metal filings from drilling are to be vacuumed from the enclosure interiors.
- .11 All lamicoïd nameplates shall have a minimum border of 3 mm (1/8"). Characters shall be 9 mm (3/8") in size unless otherwise specified.

- .12 Provide neatly typed updated circuit directories in a plastic holder on the inside door of new panelboards.
- .13 Carefully update panelboard circuit directories whenever adding, deleting, or modifying existing circuitry.

7 WIRING IDENTIFICATION

- .1 Unless otherwise specified, identify wiring with permanent indelible identifying markings, using either numbered or coloured plastic tapes on both ends of phase conductors of feeders and branch circuit wiring.
- .2 Maintain phase sequence and colour coding throughout.

8 CONDUIT AND CABLE IDENTIFICATION

- .1 All new conduits to be colour-coded EMT, type as follows:
 - .1 Emergency power circuits – yellow conduit
 - .2 Building Automation system – orange conduit
 - .3 Control system – white conduit
- .2 Apply paint to the covers of junction boxes and condulets of existing conduits as follows:
 - .1 Emergency power circuits – yellow
 - .2 Building Automation system – orange
 - .3 Control system - white
- .3 For system running with cable, half-lap wrap with dedicated coloured PVC tape to 100 mm width, tape every 5 m and both sides where cable penetrates a wall.
- .4 All other systems need not be coloured.

9 MANUFACTURER'S & APPROVALS LABELS

- .1 Ensure that manufacturer's registration plates are properly affixed to all apparatus showing the size, name of equipment, serial number, and all information usually provided, including voltage, cycle, phase and the name and address of the manufacturer.
- .2 Do not paint over registration plates or approval labels. Leave openings through insulation for viewing the plates. Contractor's or sub-contractor's nameplate not acceptable.

10 WARNING SIGNS AND PROTECTION

- .1 Provide warning signs, as specified or to meet requirements of Authorized Electrical Inspection Department and NRC Departmental Representative.
- .2 Accept the responsibility to protect those working on the project from any physical danger due to exposed live equipment such as panel mains, outlet wiring, etc. Shield and mark all live parts with the appropriate voltage. Caution notices shall be worded in both English and French.

11 MOTOR ROTATION

- .1 For new motors, ensure that motor rotation matches the requirements of the driven equipment.
- .2 For existing motors, check rotation before making wiring changes in order to ensure correct rotation upon completion of the job.

12 GROUNDING

- .1 Thoroughly ground all electrical equipment, cabinets, metal supporting frames, ventilating ducts and other apparatus where grounding is required in accordance with the requirements of the latest edition of the Canadian Electrical Code Part 1, C.S.A. C22.1 and corresponding Provincial and Municipal regulations. Do not depend upon conduits to provide the ground circuits.
- .2 Run separate green insulated stranded copper grounding conductors in all electrical conduits including those feeding toggle switches and receptacles.

13 TESTS

- .1 Provide any materials, equipment and labour required and make such tests deemed necessary to show proper execution of this work, in the presence of the NRC Departmental Representative.
- .2 Correct any defects or deficiencies discovered in the work in an approved manner at no additional expense to the Owner.
- .3 Megger all branch circuits and feeders using a 600V tester for 240V circuits and a 1000V tester for 600V circuits. If the resistance to ground is less than permitted by Table 24 of the Code, consider such circuits defective and do not energize.
- .4 The final approval of insulation between conductors and ground, and the efficiency of the grounding system is left to the discretion of the local Electrical Inspection Department.

14 COORDINATION OF PROTECTIVE DEVICES

- .1 Ensure circuit protective devices such as overcurrent trips, fuses, are installed to values and settings as indicated on the Drawings.

15 WORK ON LIVE EQUIPMENT & PANELS

- .1 NRC requires that work be performed on non-energized equipment, installation, conductors and power panels. For purposes of quotation assume that all work is to be done after normal working hours and that equipment, installation, conductors and power panels are to be de-energized when worked upon.

END OF SECTION

Part 1 General

1.1 RELATED WORK SPECIFIED ELSEWHERE

- .1 Common Work Results - Electrical Section 26 05 00

1.2 MATERIALS

- .1 Provide only new equipment and materials, without blemish or defect, bearing Canadian Standards Association or Authorized Electrical Inspection Department labels, and subject to the approval of the NRC Departmental Representative.
- .2 After a contract is awarded, utilize alternative methods and/or materials only after receiving the NRC Departmental Representative's approval.

Part 2 Products

2.1 BUILDING WIRES AND GENERAL REQUIREMENTS

- .1 Conductor material for branch circuit wiring and grounding:
 - .1 Stranded copper.
 - .2 Neutral wire: continuous throughout its length without breaks.
 - .3 Separate insulated green grounding conductors in all electrical conduits.
 - .4 All wire and cable insulation shall meet the C.S.A. Standards for the types and services hereinafter specified. Colours as per section 4-036 of Electrical Code.
 - .5 Where otherwise specified, use wire and cable types as follows:
 - .1 Type R90 XLPE cross-link polyethylene stranded for applications using wires sized No. 8 and larger.
 - .2 Type T90 stranded for applications using wires sized No. 10 and smaller.
 - .3 For fire alarm wiring refer to Section 283100.
 - .4 Approved heat resistant wire for wiring through and at lighting and heating fixtures. Where insulation types are shown on the drawings other types shall not be used unless the specification is more restrictive.
 - .6 Use BX cable only under the following conditions:
 - .1 Wiring from a junction box to a recessed lighting fixture in suspended ceilings. Cable length not to exceed 1.5 m (5'), or
 - .2 Wiring or switches or 15 amp receptacles in partitions having removable wall panels, or
 - .3 When specifically called for on drawings.
 - .7 Use stranded wire no smaller than No. 12 AWG for lighting and power and no smaller than No. 16 AWG for control wiring.
 - .8 Conductors shall be soft copper properly refined and tinned having a minimum conductivity of 98%.

Part 3 Execution

3.1 BUILDING WIRES

- .1 Install building wires as follows:
 - .1 Make joints, taps and splices in approved boxes with solderless connectors. Joints and/or splices are not acceptable inside a panelboard.
 - .2 Ensure the lugs accommodate all the strands of the conductor.
 - .3 Replace any wire or cable showing evidence of mechanical injury.
 - .4 Use No. 10 AWG for branch circuit wiring extending more than 30 m (100 ft.) to farthest outlet from panel.
 - .5 Circuit numbers indicated on the drawing are intended as a guide for the proper connection of multi-wire circuits at the panel.
 - .6 Take care to keep the conductors free from twisting.
 - .7 Use an approved lubricant for pulling in conduit.
 - .8 Leave sufficient slack on all runs to permit proper splicing and connection of electrical devices.
 - .9 Branch circuit wiring of 120 volt applications to be multi-wire utilizing common neutrals. Under no condition shall any switch break a neutral conductor.
 - .10 Provide and install an approved fire- retardant wrap or coating for PVC jacketed cables installed in a grouped configuration of two or more.

END OF SECTION

Part 1 General

1.1 RELATED WORK SPECIFIED ELSEWHERE

- .1 Common Work Results - Electrical Section 26 05 00

1.2 MATERIALS

- .1 Provide only new equipment and materials, without blemish or defect, bearing Canadian Standards Association or Authorized Electrical Inspection Department labels, and subject to the approval of the NRC Departmental Representative.
- .2 After a contract is awarded, utilize alternative methods and/or materials only after receiving the NRC Departmental Representative's approval.

Part 2 Products

2.1 WIRE AND BOX CONNECTORS

- .1 Pressure type wire connectors sized to fit conductors.

2.2 WIRING TERMINATIONS

- .1 Provide first grade wire and cable connectors suitable for the service on which they are used and install them in accordance with the latest trade practice.
- .2 Provide high quality extruded copper-free aluminium (0.4% or less) connectors for single and multi conductor cable. Steel and then zinc plated connectors for multi conductor cables.
- .3 For large conductor sizes, use bolted or compression solderless type connectors.
- .4 Use high temperature connectors and insulation on all connections of high temperature conductors.
- .5 Where connector types are called for on the drawings or in the specification, do not use other types.
- .6 Lugs, terminals, screws used for termination of wiring to be suitable for copper conductors.

Part 3 Execution

3.1 INSTALLATION

- .1 Install stress cones, terminations, and splices in accordance with manufacturer's instructions.
- .2 Bond and ground as required [to CSA C22.2No.41].

END OF SECTION

Part 1 General

1.1 RELATED WORK SPECIFIED ELSEWHERE

- .1 Common Work Results - Electrical Section 26 05 00

1.2 MATERIALS

- .1 Provide only new equipment and materials, without blemish or defect, bearing Canadian Standards Association or Authorized Electrical Inspection Department labels, and subject to the approval of the NRC Departmental Representative.
- .2 After a contract is awarded, utilize alternative methods and/or materials only after receiving the NRC Departmental Representative's approval.

Part 2 Products

2.1 FITTINGS

- .1 Fittings: manufactured for use with conduit specified. Coating: same as conduit.
- .2 Steel coupling for EMT.
- .3 Fittings for liquid-tight flexible conduits shall be liquid-tight connectors.
- .4 Provide expansion couplings for all conduits running in slabs through expansion joints. These shall be the type approved for use in concrete with a bonding conductor.
- .5 Factory bends are not permitted to be modified. Ensure conduit bends other than factory bends are made with an approved bender. Making offsets and other bends by cutting and rejoining factory bends are not permitted.

2.2 OUTLET BOXES

- .1 Size boxes in accordance with CSA-C22.
- .2 Unless otherwise specified, provide galvanized steel outlet boxes at least 40mm (1-1/2") deep, single or ganged style, of proper size to accommodate devices used and shall be equipped with covers as necessary of the type designed for the specified fittings. Pull boxes shall be steel and shall be galvanized or painted to prevent rusting. For lighting fixture outlets, use 100mm (4") octagon boxes.
- .3 Equip with plaster rings for flush mounting devices in finished walls.
- .4 Blank cover plates for boxes without wiring devices.
- .5 Equip with centre fixture studs for light fixtures.

- .6 Use cast boxes where indicated and for surface mounted wiring. In areas above hung ceilings where appearance is not significant, pressed steel surface boxes may be used.
- .7 Supply all outlet boxes and pull boxes sized according to code requirements unless specified otherwise on the drawings.

2.3 SUPPORT HARDWARE

- .1 Use 10mm (3/8") threaded rod for suspended unistrut and conduit.
- .2 Unless otherwise specified, use 41mm x 41mm (1-5/8" x 1-5/8") galvanized steel unistrut for conduit support systems.

Part 3 Execution

3.1 INSTALLATION

- .1 Install outlet boxes as follows:
 - .1 Support boxes independently of connecting conduits.
 - .2 Make necessary mounting adjustments to the outlet to match interior finish.
 - .3 Fill boxes with paper, sponges or foam or similar approved material to prevent entry of construction material.
 - .4 Where more than one conduit enters a switch or receptacle box on the same side, provide a 100mm (4") minimum square box with a suitable plaster ring.
 - .5 Location and appearance to be to the NRC Departmental Representative's approval.

END OF SECTION

Part 1 General

1.1 RELATED WORK SPECIFIED ELSEWHERE

- .1 Common Work Results - Electrical Section 26 05 00

1.2 MATERIALS

- .1 Provide only new equipment and materials, without blemish or defect, bearing Canadian Standards Association or Authorized Electrical Inspection Department labels, and subject to the approval of the NRC Departmental Representative.
- .2 After a contract is awarded, utilize alternative methods and/or materials only after receiving the NRC Departmental Representative's approval.

Part 2 Products

2.1 RACEWAYS

- .1 Conduit:
 - .1 Each length of conduit to be new and bear the CSA Stamp of Approval.
 - .2 Conduit, unless otherwise noted, to be EMT, no smaller than 12mm (1/2").
 - .3 Conduit to be coloured as required for systems described in section 260500.9.
- .2 Bushings and Connectors:
 - .1 Insulated type, with the insulation an integral part of the fitting.
- .3 Conduit Fastening:
 - .1 One hole malleable iron straps to secure surface conduits. Two hole straps for conduits larger than 50mm (2").
 - .2 Beam clamps to secure conduits to exposed steel work.
 - .3 Channel type supports for two or more conduits.
- .4 Pull Cord:
 - .1 Polypropylene cord in empty conduit.
- .5 Unless specifically called for on the drawings, do not use flexible conduits but it is recognized that there may be applications where this material will be useful, such as equipment connections, etc. In such cases, obtain permission for its use from the NRC Departmental Representative. For tender purposes, assume that flexible conduits will not be permitted unless specifically called for on the drawings or equipment specifications. All flexible conduits for vapour-tight applications shall be liquid-tight flexible conduits (seal-tight).
- .6 Provide expansion couplings for all conduits running in slabs through expansion joints. These shall be the type approved for use in concrete with a bonding conductor.

2.2 SUPPORT HARDWARE

- .1 Use 10mm (3/8") threaded rod for suspended unistrut and conduit.
- .2 Unless otherwise specified, use 41mm x 41mm (1-5/8" x 1-5/8") galvanized steel unistrut for conduit support systems.

Part 3 Execution

3.1 RACEWAYS

- .1 Install raceways as follows:
 - .1 Rigidly supported.
 - .2 Workmanlike manner.
 - .3 Maintain maximum headroom.
 - .4 Concealed in finished area.
 - .5 Surface-mounted in open area.
 - .6 Do not pass conduits through structural members except as indicated.
 - .7 Parallel to or at right angles to the building lines.
 - .8 Thoroughly ream all conduits at ends and terminate with appropriate locknuts and bushings.
 - .9 Cause minimum interference in spaces through which they pass.
 - .10 Plug or cap conduit during construction to protect from dust, dirt or water.
 - .11 Unless specifically indicated on drawings or with the permission of the NRC Departmental Representative, do not cast conduits in concrete.
 - .12 Dry conduits out before installing wire.
 - .13 Mechanically bend steel conduit larger than 22 mm (3/4") diameter. Bend conduit cold.
 - .14 Do not cut or modify prefabricated bends.
 - .15 PVC conduit as indicated.
 - .16 Function and appearance to be to the NRC Departmental Representative's approval.
 - .17 Seal conduit and cable openings in fire- rated walls and floors with an approved fire stop material.
 - .18 Seal conduit and cable openings in exterior walls with a weatherproof silicone sealant.
 - .19 Paint exposed conduits and boxes to match existing wall / ceiling except the colored EMT specified in 260500.

END OF SECTION

Part 1 General

1.1 SHOP DRAWINGS AND PRODUCT DATA

- .1 Submit shop drawing and product data in accordance with Section 00 10 00.

1.2 IDENTIFICATION

- .1 Identification as per Section 26 05 00.

Part 2 Products

2.1 DISCONNECT SWITCHES, FUSED AND NON-FUSED

- .1 Fusible and non-fusible disconnect switches in EEMAC Enclosure as indicated.
- .2 Provision for padlocking in "OFF" switch position.
- .3 Mechanical voidable door interlock in "ON" position.
- .4 Fuses: size and type as indicated.
- .5 Fuseholders in each switch to be suitable without adaptors, for type and size of fuse indicated.
- .6 Quick-make, quick-break action.
- .7 "ON-OFF" switch position indication on switch enclosure cover.
- .8 Standard of acceptance: Square D, Cutler-Hammer, Siemens.

2.2 GROUNDING

- .1 Insulated grounding conductors in accordance with Section 26 05 00.
- .2 Compression connectors for grounding to equipment provided with lugs.

2.3 MOULDED CASE CIRCUIT BREAKER

- .1 Thermal-magnetic moulded case circuit breakers, quick-make, quick-break type, for manual and automatic operation with temperature compensation for 40°C ambient.
- .2 Common-trip breakers with single handle for multiple applications.
- .3 All new 120V to 600V circuit breakers installed on this project are to include the handle accessory, "Handle Padlock Attachment", which locks breakers on or off.
- .4 Magnetic instantaneous trip elements in circuit breakers, to operate only when the value of current reaches 10 times their setting.

- .5 Circuit breaker and panel to be of same manufacturer.
- .6 Circuit breakers minimum rating: 10K for 120/240V and 25K for 600/347V or greater if indicated.
- .7 Standard of acceptance: Square D or approved equal.

2.4 FUSES

- .1 250V and 600V time delay, rejection style, HRC-I, Class RK5.
- .2 Standard of acceptance: Gould-Shawmut or approved equal.

Part 3 Execution

3.1 DISCONNECT SWITCHES

- .1 Install disconnect switches complete with fuses as indicated.

3.2 GROUNDING

- .1 Install complete permanent, continuous, system and circuit, equipment, grounding systems including, conductors, compression connectors, accessories, as indicated, to conform to requirements of Engineer, and local authority having jurisdiction over installation. Where EMT is used, run ground wire in conduit.
- .2 Install connectors in accordance with manufacturer's instructions.
- .3 Protect exposed grounding conductors from mechanical injury.
- .4 Soldered joints not permitted.

3.3 MOULDED CASE CIRCUIT BREAKERS

- .1 Install circuit breakers as indicated.

3.4 FUSES

- .1 Install fuses in mounting devices immediately before energizing circuit.
- .2 Install fuses correctly sized to assigned electrical circuits.
- .3 Provide 3 spare fuses for each rating supplied.

END OF SECTION

Part 1 General

1.1 MATERIALS

- .1 Provide only new equipment and materials, without blemish or defect, bearing Canadian Standards Association or Authorized Electrical Inspection Department labels, and subject to the approval of the NRC Departmental Representative.
- .2 After a contract is awarded, utilize alternative methods and/or materials only after receiving the NRC Departmental Representative's approval.

1.2 SHOP DRAWINGS AND PRODUCT DATA

- .1 Submit shop drawings and product data in accordance with Section 00 10 00.

1.3 IDENTIFICATION

- .1 Identification as per Section 26 05 00.

Part 2 Products

2.1 WIRING DEVICES

- .1 Receptacles:
 - .1 Duplex type, CSA type 5-15R, 125 volt, 15A, U ground, specification grade with the following features:
 - .1 Flush type with parallel blade slots.
 - .2 Double-wiping contacts.
 - .3 Double-grounding terminals.
 - .4 Break-off feature for separate feeds.
 - .5 One piece body, colour white unless otherwise indicated.
 - .2 Special receptacles with ampacity and voltage as indicated.
 - .3 Receptacles of one manufacturer throughout the project.
- .2 Cover Plates:
 - .1 Cover plates for wiring devices.
 - .2 Smooth white plastic for wiring devices mounted in flush-mounted outlet box.
 - .3 Sheet metal cover plates for wiring devices mounted in surface-mounted outlet box.
 - .4 Weatherproof covers to be die case aluminum. Standard of acceptance: Hubbell WPFS26.
 - .5 Multi-outlet covers as indicated.
- .3 Splitters, Junction Boxes & Cabinets:

- .1 Sheet metal enclosure, welded corners and formed cover, provided as required.

Part 3 Execution

3.1 LOCATION OF OUTLETS

- .1 The number and general location of outlets for power, are to be as shown on the drawings. Install all outlets accurately and uniformly with respect to building details. When centering outlets, make allowance for overhead pipes, ducts, etc. and for variations in wall or ceiling finish, window trim, etc. Reinstall incorrectly installed outlets at no cost to the Owner. Make field power and control connections as indicated.
- .2 The location of all outlets as shown on the plans are approximate and are subject to change, up to 3m (10') without extra cost or credit provided the information is given prior to the installation of the outlet.

3.2 WIRING DEVICES

- .1 Install wiring devices as follows:
 - .1 Install single throw switches with handle in "up" position when switch closed.
 - .2 Install metal barriers where required.
 - .3 Remove insulation carefully from ends of conductors and connect wiring as required.
 - .4 Bond and ground as required.

3.3 SPLITTERS AND DEVICES

- .1 Installation of splitters, junction boxes, pull boxes & cabinets as follows:
 - .1 Mount plumb, true and square to the building lines.
 - .2 Install in inconspicuous but accessible locations.
 - .3 Install pull boxes so as not to exceed 30 m (100') of conduit run between boxes or as indicated.

END OF SECTION

Part 1 General

1.1 RELATED WORK SPECIFIED ELSEWHERE

- .1 Common Work Results - Electrical Section 26 05 00

1.2 MATERIALS

- .1 Provide only new equipment and materials, without blemish or defect, bearing Canadian Standards Association or Authorized Electrical Inspection Department labels, and subject to the approval of the NRC Departmental Representative.
- .2 After a contract is awarded, utilize alternative methods and/or materials only after receiving the NRC Departmental Representative's approval.

1.3 SHOP DRAWINGS AND PRODUCT DATA

- .1 Submit shop drawings and product data in accordance with Section 001000.
- .2 Submit complete photometric data prepared by independent testing laboratory for luminaires where specified, for review by NRC Departmental Representative.

Part 2 Products

2.1 FINISHES

- .1 Baked enamel finish.
 - .1 Metal surfaces of luminaire housing and reflectors finished with high gloss powder coated baked enamel applied after fabrication to give smooth uniform appearance, free from pinholes or defects.

2.2 METAL SURFACES

- .1 Metal surfaces to be minimum 20 gauge steel.

2.3 LIGHT CONTROL DEVICES

- .1 All luminaire lenses to be injection moulded clear virgin acrylic unless otherwise noted.

2.4 LUMINAIRES

- .1 LED
 - .1 Type 1:
 - .1 120V, 1140-1220mm long, LED linear strip, suitable for surface or suspended mounting.
 - .2 5-year warranty.
 - .3 Rated to deliver L70 performance for 100,000 hours.

- .4 4000k colour temperature, minimum 3800 lumen output.
- .5 Standard of acceptance: Philips Fluxstream LF-4-FR-39-40-U-LAG, Peerless Electric NSL-4-46-40k-RA-WH-MV, CREE LS4-40L-40K-10V or equivalent approved by the NRC Departmental Representative.

Part 3 Execution

3.1 INSTALLATION

- .1 Supply and install all lighting fixtures complete with switches, supports, etc., to provide a complete working lighting system.
- .2 Locate and install luminaires as indicated.

3.2 LUMINAIRE ALIGNMENT

- .1 Align luminaires mounted in continuous rows to form a straight uninterrupted line.
- .2 Align luminaires mounted individually parallel or perpendicular to building grid lines as shown on drawing.

END OF SECTION

Part 1 General

1.1 RELATED WORK SPECIFIED ELSEWHERE

- .1 Common Work Results - Electrical Section 26 05 00

1.2 MATERIALS

- .1 Provide only new equipment and materials, without blemish or defect, bearing Canadian Standards Association or Authorized Electrical Inspection Department labels, and subject to the approval of the NRC Departmental Representative.
- .2 After a contract is awarded, utilize alternative methods and/or materials only after receiving the NRC Departmental Representative's approval.

1.3 SHOP DRAWINGS AND PRODUCT DATA

- .1 Submit shop drawings and product data in accordance with Section 00 10 00.

1.4 SCOPE OF WORK

- .1 Supply and install all required material, equipment and labour to provide the fire alarm changes and additions as shown on the drawings and indicated by this section of the specification.

1.5 CONTRACTOR QULIFICATION

- .1 The contractor must ensure the supervisor, site foreman and electrician working on site hold valid fire alarm certificate.

1.6 REFERENCES

- .1 Government of Canada
 - .1 TB OSH Chapter 3-03, [latest edition], Treasury Board of Canada, Occupational Safety and Health, Chapter 3-03, Standard for Fire protection Electronic Data Processing Equipment.
 - .2 TB OSH Chapter 3-04, [latest edition], Treasury Board of Canada, Occupational Safety and Health, Chapter 3-04, Standard for Fire Alarm Systems.
- .2 Treasury Board: Fire Protection Standard effective April 1, 2010
- .3 Health Canada/Workplace Hazardous Materials Information System (WHMIS)
 - .1 Material Safety Data Sheets (MSDS).
- .4 Underwriter's Laboratories of Canada (ULC)
 - .1 CAN/ULC-S524-[latest edition], Standard for the Installation of Fire Alarm Systems.
 - .2 CAN/ULC-S525-[latest edition], Audible Signal Device for Fire Alarm Systems.

- .3 CAN/ULC-S526-[latest edition], Visual Signal Devices for Fire Alarm Systems.
 - .4 CAN/ULC-S527-[latest edition], Control Units.
 - .5 CAN/ULC-S528-[latest edition], Manual Pull Stations for Fire Alarm Systems.
 - .6 CAN/ULC-S529-[latest edition], Smoke Detectors for Fire Alarm Systems.
 - .7 CAN/ULC-S530-[latest edition], Heat Actuated Fire Detectors for Fire Alarm Systems.
 - .8 CAN/ULC-S531-[latest edition], Standard for Smoke Alarms.
 - .9 CAN/ULC-S536-S537-[latest edition], Burglar and Fire Alarm Systems and Components.
- .5 National Fire Protection Agency
- .1 NFPA 72-[latest edition], National Fire Alarm Code.
 - .2 NFPA 90A-[latest edition], Installation of Air Conditioning and Ventilating Systems.

Part 2 Products

2.1 AUTOMATIC ALARM INITIATING DEVICES

- .1 Conventional system
 - .1 Combination Fixed temperature and rate-of-rise thermal fire detector, self-restoring, rated 57°C (135°F) with 8.3°C (15°F) rate-of-rise, single circuit. Edwards model No. 5601A.

2.2 CONDUIT AND WIRING

- .1 Raceway to be 16mm EMT unless indicated otherwise on the drawings. Wiring between junction box on underside of slab and heat detector junction box in T-bar ceiling to be 21mm flexible conduit.
- .2 All wiring is to be colour coded to match existing system and is to be of stranded copper.
- .3 Zone wiring is to be #16 TEW colour coded stranded copper.
- .4 Signal wiring to be sized to take into account voltage drop and is not to be smaller than #12 TW colour coded stranded copper.

Part 3 Execution

3.1 CONDUIT AND WIRING

- .1 All fire alarm trouble and alarm zone wiring to be class "A" using #16 TEW colour coded stranded copper wire, and in accordance with manufacturer's requirements. Connect two red and two zone colour wires to each device. If the colour coding is not given on drawings, coding will be provided after contract is awarded.

- .2 Run all four zone or signal circuit wires in the same conduit (i.e. Do not install only two of the four zone wires in a conduit - all four zone wires must be in each conduit.)
- .3 All conduit to include a #16 TW stranded copper green ground wire.
- .4 Use only uninsulated ring-type STA-KON lugs on screw connections.
- .5 Run conduit tight along underside of ceiling slab or roof deck, unless noted otherwise on drawings.
- .6 Leave 6 inch loops of wire in all junction boxes.
- .7 For new installations, no splicing of wires is to be made.
- .8 For renovations, splices may be made in junction boxes other than those at heat detectors after receiving approval of the NRC Departmental Representative. All splices must be soldered and taped.
- .9 Upon awarding of the contract, the NRC Departmental Representative shall provide the contractor with the standard wiring diagram for detection devices, A-7481.
- .10 Prior to installing raceways, submit to the NRC Departmental Representative a proposed method and layout of conduit for approval.

3.2 EQUIPMENT IDENTIFICATION

- .1 Label each manual alarm station and each audible signal device with its unique identification number as per drawings. Use lamicoïd nameplates as per Section 26 05 00.
- .2 Label each initiating device use P-Touch type as per Section 26 05 00. Devices are to be numbered per the format shown below.

Example M-10 fire alarm #1 Heat detector 000001
10FAS-01-GND-HD-000001

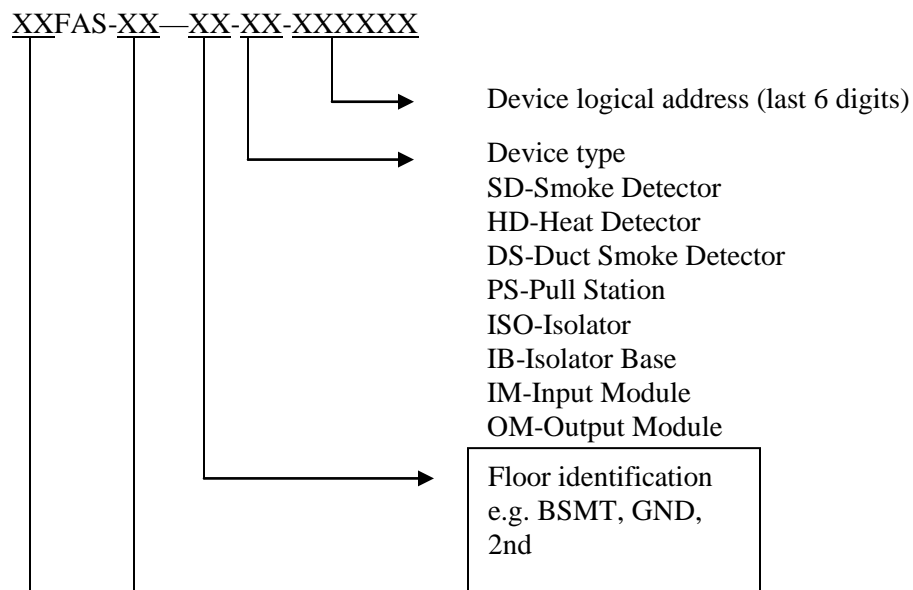

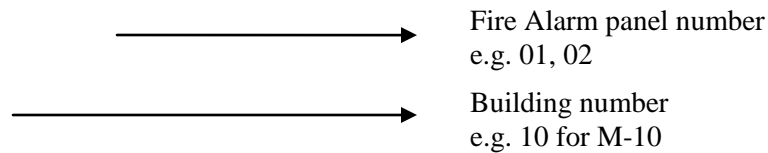

- .3 Apply red paint to the covers of junction boxes and condulets of fire alarm conduit.
- .4 Label wires as per drawing and as per Section. 26 05 00.
- .5 Update remote annunciator panels and fire alarm panel zone directories if new zones are added to the system.

3.3 SCHEDULING OF SHUTDOWNS

- .1 Make written shutdown request to the NRC Departmental Representative at least 48 hours in advance. Acceptance of shutdown request will be determined by the NRC Departmental Representative based on building user needs. Fire alarm systems are to be shut down by NRC staff only. **Contractor is not to shutdown system on their own.**

3.4 INTEGRATION INTO SYSTEM MONITORING AT BUILDING M-1

Presently all NRC buildings in Ottawa report back their fire alarm status to the M1 building central monitoring station. The monitoring station consists of a computer graphics terminal showing building layouts of each building, and is linked on an internal NRC network. The new fire alarm system under this contract must communicate all addressable input points to the existing computer graphics monitoring station, Fireworks by Chubb Edwards. All required modifications to the existing Fireworks station are to be included in this tender.

- .1 Conventional (non-addressable) devices:
 - .1 Integrate any new zones installed as part of this project into the monitoring system at building M-1. This is to be done by factory trained technician.
 - .2 Remove from the monitoring system at building M-1 any zones removed as part of this project.
 - .3 Make appropriate changes to the monitoring system at building M-1 to reflect any zone location changes as appropriate.
 - .4 All work on the monitoring system at building M-1 is to be done by factory trained technician.

3.5 ACCEPTANCE TEST

- .1 Perform tests in accordance with the latest regulations and in the presence of the NRC Departmental Representative and the representative of the regulating authority.

- .2 Test each device and alarm circuit to ensure manual alarm stations, thermal and smoke detectors transmit alarms to control panel and actuate alarm.
- .3 Check annunciator panels to ensure that the correct zones are activated.
- .4 Simulate grounds and breaks on alarm and signalling circuits to ensure proper operation of trouble signals.
- .5 Record amperage drawn by audible signal device circuits if new audible signal devices have been added to the circuit.
- .6 Give the NRC Departmental Representative one set of marked in red prints labelled "As Built".
- .7 Provide the NRC Departmental Representative with a letter of verification from the manufacturer of the equipment stating that the equipment supplied under this contract has been installed as per the latest CAN/ULC S537 and CAN/ULC-S524 standards and as per the latest edition of the Ontario Building Code.

END OF SECTION

Part 1 General

1.1 REFERENCES

- .1 American Society for Testing and Materials International, (ASTM).
 - .1 ASTM A53/A53M-02, Standard Specification for Pipe, Steel, Black and Hot-Dipped, Zinc-Coated Welded and Seamless.
 - .2 ASTM A90/A90M-01, Standard Test Method for Weight [Mass] of Coating on Iron and Steel Articles with Zinc or Zinc-Alloy Coatings.
 - .3 ASTM A121-99, Standard Specification for Zinc-Coated (Galvanized) Steel Barbed Wire.
 - .4 A653/A653M-03, Standard Specification for Steel Sheet, Zinc-Coated (Galvanized) or Zinc-Iron Alloy-Coated (Galvannealed) by the Hot-Dip Process.
 - .5 ASTM C618-03, Standard Specification for Coal Fly Ash and Raw or Calcined Natural Pozzolan for Use as a Mineral Admixture in Concrete.
- .2 Canadian Standards Association (CSA International)
 - .1 CSA-A23.1/A23.2-04, Concrete Materials and Methods of Concrete Construction/Methods of Test and Standard Practices for Concrete.
 - .2 CSA-G164-M92 (R2003), Hot Dip Galvanizing of Irregularly Shaped Articles.
- .3 Canadian General Standards Board (CGSB).
 - .1 CAN/CGSB-138.1-96, Fabric for Chain Link Fence.
 - .2 CAN/CGSB-138.2-96, Steel Framework for Chain Link Fence.
 - .3 CAN/CGSB-138.3-96, Installation of Chain Link Fence.
 - .4 CAN/CGSB-138.4-96, Gates for Chain Link Fence.
 - .5 CAN/CGSB-1.181-99, Ready-Mixed Organic Zinc-Rich Coating.
- .4 Ontario Provincial Standard Specifications (OPSS)
 - .1 OPSS 772 – Construction Specification for Chain Link Fence.
 - .1 OPSS 772 shall apply except as amended or extended herein.
 - .1 Article 772.10 Basis of Payment shall be deleted, as all costs associated with the supply and installation of chain link fencing shall be included in the lump sum project costs.

1.2 WASTE MANAGEMENT AND DISPOSAL

- .1 Waste Management and Disposal:
 - .1 The Contractor is responsible to coordinate and dispose of all waste material to local Provincial and Municipal requirements.
- .2 It is the full responsibility of the Contractor to insure that all construction material, equipment, tools, etc. are stored and used in a safe and reasonable manor as per good industry standards.
- .3 The Contractor is responsible for all damaged and stolen material, tools or equipment on site.
- .4 The Contractor is responsible for the delivery of all material, tools or equipment.

1.3 SHOP DRAWINGS

- .1 Submit shop drawings in accordance with section 00 10 00 – General Instructions.

Part 2 Products

2.1 MATERIALS

- .1 Chain link fence fabric, posts and rails, diagonal wire braces, top and bottom wires, gates, fittings and accessories, turnbuckles and barbed wires and associated accessories shall be in accordance with OPSS 1541.
- .2 Concrete mixes and materials: in accordance with CAN/CSA-A23.1.
 - .1 Nominal coarse aggregate size: 20-5.
 - .2 Compressive strength: 25 MPa minimum at 28 days.
 - .3 5 to 8% air entrainment.
 - .4 Additives: fly ash to CAN/CSA-A23.5.
- .3 Chain link fence fabric: to CAN/CGSB-138.1.
 - .1 Type 1, Class A heavy style, #9 gauge steel wire woven in 50.8mm mesh.
 - .2 Height of fabric: 1.8m.
 - .3 Acceptable material: galvanized steel.
- .4 Top rail and mid brace: 32mm diameter schedule 40 galvanized steel to CAN/CGSB-138.2.
- .5 Corner/End/Gate posts (G-1, G-2 and G-3): 100mm diameter schedule 40 galvanized steel to CAN/CGSB-138.2.
- .6 Bottom tension wire: to CAN/CGSB-138.1, single strand, 6 gauge galvanized steel wire.
- .7 Tie wire fasteners: to CAN/CGSB-138.1, single strand minimum 14 gauge aluminum alloy wire.
- .8 Tension bar: to ASTM A653/A653M, 6 x 25mm minimum galvanized steel.
- .9 Access / Egress Gates: to CAN/CGSB-138.4. All gates shall be equipped with key operated locking hardware restricting access but allowing egress via a tamperproof panic rim exit device The locking hardware barrels shall be keyed to NRC key schemes.
 - .1 Panic Rim Exit Device Standard of Acceptance: Von Duprin XP98/99. Installed as per manufacturer's instructions and made tamperproof with aluminum plates in similar fashion to existing installations around NRC campus.
- .10 Gate frames: to ASTM A53/A53M, galvanized steel pipe, standard weight 45mm outside diameter pipe for outside frame, 35mm outside diameter pipe for interior bracing.
 - .1 Fabricate gates as indicated with electrically welded joints, and hot-dip galvanized after welding.
 - .2 Fasten fence fabric to gate with twisted selvage at top.
 - .3 Furnish gates with galvanized malleable iron hinges, latch and latch catch with provision for padlock which can be attached and operated from either side of installed gate.

- .4 Furnish double gates with chain hook to hold gates open and centre rest (300mm x 300mm x 150mm deep concrete rest – flush with grade) with drop bolt for closed position.
- .11 Fittings and hardware: to CAN/CGSB-138.2, galvanized steel.
 - .1 Tension bar bands: 3 x 20mm minimum galvanized steel.
 - .2 Post caps to provide waterproof fit, to fasten securely over posts and to carry top rail.
 - .3 Overhang tops to provide waterproof fit, to hold top rails and an outward projection to hold barbed wire overhang.
 - .4 Provide projection with clips or recesses to hold 3 strands of barbed wire spaced 100mm apart.
 - .5 Projection of approximately 300mm long to project from fence at 45 degrees above horizontal.
 - .6 Turnbuckles to be drop forged.
- .12 Organic zinc rich coating: to CAN/CGSB-1.181.
- .13 Barbed wire: to CAN/CGSB-138.2, minimum 2mm diameter galvanized steel wire to ASTM A121, 4 point barbs with 125mm spacing, alternate spacing between 3 rolls.

2.2 FINISHES

- .1 Galvanizing:
 - .1 For chain link fabric: to CAN/CGSB-138.1 Grade 2.
 - .2 For pipe: 550 g/m² minimum to ASTM A90.
 - .3 For barbed wire: to CAN/CGSB-138.2.
 - .4 For other fittings: to CAN/CSA-G164.

Part 3 Execution

3.1 GRADING

- .1 Remove debris and correct ground undulations along fence line to obtain smooth uniform gradient between posts.
 - .1 Provide clearance between bottom of fence and ground surface of 30mm to 50mm.

3.2 ERECTION OF FENCE

- .1 Erect fence along lines as indicated on Contract Documents and to CAN/CGSB-138.3.
- .2 Fencing shall be erected a minimum of 3m from the pavement edge of all paved roadways.
- .3 Excavate post holes to bedrock or dimensions indicated and methods approved by the Departmental Representative.
- .4 Space line posts maximum 3m apart, measured parallel to ground surface.
- .5 Space straining posts at equal intervals not to exceed 150m if distance between end or corner posts on straight continuous lengths of fence over reasonably smooth grade, is greater than 150m.

- .6 Install additional straining posts at sharp changes in grade and where directed by Departmental Representative.
- .7 Install corner post where change in alignment exceeds 10 degrees.
- .8 Install end posts at end of fence and at buildings.
 - .1 Install gate posts on both sides of gate openings.
- .9 Place concrete in post holes then embed posts into concrete.
 - .1 Extend concrete 50mm above ground level and slope to drain away from posts.
 - .2 Brace to hold posts in plumb position and true to alignment and elevation until concrete has set.
- .10 Do not install chain link fence fabric until concrete has cured minimum of 5 days.
- .11 Install brace between end and gate posts and nearest line post, placed in centre of panel and parallel to ground surface.
 - .1 Install braces on both sides of corner and straining posts in similar manner.
- .12 Install overhang tops and caps.
- .13 Install top rail between posts and fasten securely to posts and secure waterproof caps and overhang tops.
- .14 Install bottom tension wire, stretch tightly and fasten securely to end, corner, gate and straining posts with turnbuckles and tension bar bands. Wire to be located 25mm above finished grade.
- .15 Lay out chain link fence fabric. Stretch tightly to tension recommended by manufacturer and fasten to end, corner gate and straining posts with tension bar secured to post with tension bar bands spaced at 300mm intervals.
 - .1 Knuckled selvedge at bottom.
 - .2 Twisted selvedge at top.
 - .3 Base of fabric to be a maximum of 25mm above finished grade.
- .16 Secure fabric to top rails, line posts and bottom tension wire with tie wires at 450mm intervals.
 - .1 Give tie wires minimum two twists.
- .17 Install barbed wire strands and clip securely to lugs of each projection.

3.3 INSTALLATION OF GATES

- .1 Install gates in locations as indicated on Contract Documents.
- .2 Level ground between gate posts and set gate bottom approximately 40mm above ground surface.
- .3 Determine position of centre gate rest for double gate.
 - .1 Cast gate rest in concrete as directed.
 - .2 Dome concrete above ground level to shed water.

- .4 Install gate stops where indicated.

3.4 TOUCH UP

- .1 Clean damaged surfaces with wire brush removing loose and cracked coatings. Apply two coats of organic zinc-rich paint to damaged areas.
 - .1 Pre-treat damaged surfaces according to manufacturers' instructions for zinc-rich paint.

3.5 CLEANING

- .1 Proceed in accordance with section 00 10 00 – General Instructions.
- .2 Clean and trim areas disturbed by operations.
 - .1 Dispose of surplus materials.
 - .2 Repair and re-instate any damaged items (ie. existing fencing, fence posts, grass, asphalt, etc.) to original or better condition.

3.6 REFERENCE SKETCH

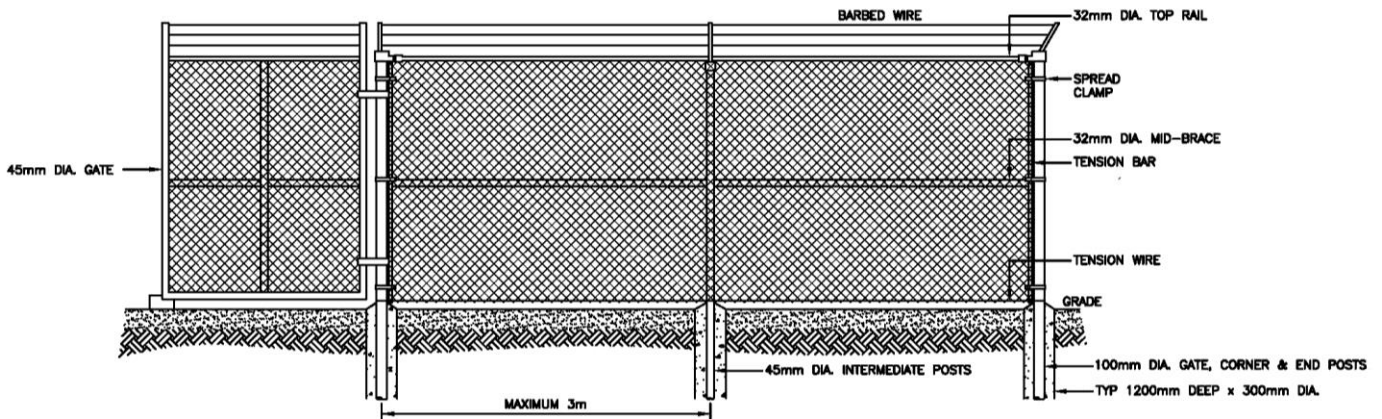

END OF SECTION



TP1 Amount Payable – General

1.1 Subject to any other provisions of the contract, Her Majesty shall pay the Contractor, at the times and in the manner hereinafter set out, the amount by which

1.1.1 the aggregate of the amounts described in TP2 exceeds

1.1.2 the aggregate of the amounts described in TP3

and the Contractor shall accept that amount as payment in full satisfaction for everything furnished and done by him in respect of the work to which the payment relates.

TP2 Amounts Payable to the Contractor

2.1 The amounts referred to in TP1.1.1 are the aggregate of

2.1.1 the amounts referred to in the Articles of Agreement, and

2.1.2 the amounts, if any, that are payable to the Contractor pursuant to the General Conditions.

TP3 Amounts Payable to Her Majesty

3.1 The amounts referred to in TP1.1.2 are the aggregate of the amounts, in any, that the Contractor is liable to pay Her Majesty pursuant to the contract.

3.2 When making any payments to the Contractor, the failure of Her Majesty to deduct an amount referred to in TP3.1 from an amount referred to in TP2 shall not constitute a waiver of the right to do so, or an admission of lack of entitlement to do so in any subsequent payment to the Contractor.

TP4 Time of Payment

4.1 In these Terms of Payment

4.1.1 The “payment period” means a period of 30 consecutive days or such other longer period as is agreed between the Contractor and the Departmental Representative.

4.1.2 An amount is “due and payable” when it is due and payable by Her Majesty to the Contractor according to TP4.4, TP4.7 or TP4.10.

4.1.3 An amount is overdue when it is unpaid on the first day following the day upon which it is due and payable.

4.1.4 The “date of payment” means the date of the negotiable instrument of an amount due and payable by the Receiver General for Canada and given for payment.

4.1.5 The “Bank Rate” means the discount rate of interest set by the Bank of Canada in effect at the opening of business on the date of payment.



- 4.2 The Contractor shall, on the expiration of a payment period, deliver to the Departmental Representative in respect of that payment period a written progress claim that fully describes any part of the work that has been completed, and any material that was delivered to the work site but not incorporated into the work during that payment period.
- 4.3 The Departmental Representative shall, not later than ten days after receipt by him of a progress claim referred to in TP4.2,
- 4.3.1 inspect the part of the work and the material described in the progress claim; and
- 4.3.2 issue a progress report, a copy of which the Departmental Representative will give to the Contractor, that indicates the value of the part of the work and the material described in the progress claim that, in the opinion of the Departmental Representative,
- 4.3.2.1 is in accordance with the contract, and
- 4.3.2.2 was not included in any other progress report relating to the contract.
- 4.4 Subject to TP1 and TP4.5 Her Majesty shall, not later than 30 days after receipt by the Departmental Representative of a progress claim referred to in TP4.2, pay the Contractor
- 4.4.1 an amount that is equal to 95% of the value that is indicated in the progress report referred to in TP4.3.2 if a labour and material payment bond has been furnished by the Contractor, or
- 4.4.2 an amount that is equal to 90% of the value that is indicated in the progress report referred to in TP4.3.2 if a labour and material payment bond has not been furnished by the Contractor.
- 4.5 It is a condition precedent to Her Majesty's obligation under TP4.4 that the Contractor has made and delivered to the Departmental Representative,
- 4.5.1 a statutory declaration described in TP4.6 in respect of a progress claim referred to in TP4.2,
- 4.5.2 in the case of the Contractor's first progress claim, a construction schedule in accordance with the relevant sections of the Specifications, and
- 4.5.3 if the requirement for a schedule is specified, an update of the said schedule at the times identified in the relevant sections of the Specifications.
- 4.6 A statutory declaration referred to in TP4.5 shall contain a deposition by the Contractor that
- 4.6.1 up to the date of the Contractor's progress claim, the Contractor has complied with all his lawful obligations with respect to the Labour Conditions; and
- 4.6.2 up to the date of the Contractor's immediately preceding progress claim, all lawful obligations of the Contractor to subcontractors and suppliers of material in respect of the



work under the contract have been fully discharged.

- 4.7 Subject to TP1 and TP4.8, Her Majesty shall, not later than 30 days after the date of issue of an Interim Certificate of Completion referred to in GC44.2, pay the Contractor the amount referred to in TP1 less the aggregate of
- 4.7.1 the sum of all payments that were made pursuant to TP4.4;
 - 4.7.2 an amount that is equal to the Departmental Representative's estimate of the cost to Her Majesty or rectifying defects described in the Interim Certificate of Completion; and
 - 4.7.3 an amount that is equal to the Departmental Representative's estimate of the cost to Her Majesty of completing the parts of the work described in the Interim Certificate of Completion other than the defects referred to in TP4.7.2.
- 4.8 It is a condition precedent to Her Majesty's obligation under TP4.7 that the Contractor has made and delivered to the Departmental Representative,
- 4.8.1 a statutory declaration described in TP4.9 in respect of an Interim Certificate of Completion referred to in GC44.2, and
 - 4.8.2 if so specified in the relevant sections of the Specifications, and update of the construction schedule referred to in TP4.5.2 and the updated schedule shall, in addition to the specified requirements, clearly show a detailed timetable that is acceptable to the Departmental Representative for the completion of any unfinished work and the correction of all defects.
- 4.9 A statutory declaration referred to in TP4.8 shall contain a deposition by the contractor that up to the date of the Interim Certificate of Completion the Contractor has
- 4.9.1 complied with all of the Contractor's lawful obligations with respect to the Labour Conditions;
 - 4.9.2 discharged all of the Contractor's lawful obligations to the subcontractors and suppliers of material in respect of the work under the contract; and
 - 4.9.3 discharged the Contractor's lawful obligations referred to in GC14.6.
- 4.10 Subject to TP1 and TP4.11, Her Majesty shall, not later than 60 days after the date of issue of a Final Certificate of Completion referred to in GC44.1, pay the Contractor the amount referred to in TP1 less the aggregate of
- 4.10.1 the sum of all payments that were made pursuant to TP4.4; and
 - 4.10.2 the sum of all payments that were made pursuant to TP4.7.
- 4.11 It is a condition precedent to Her Majesty's obligation under TP4.10 that the Contractor has made and delivered a statutory declaration described in TP4.12 to the Departmental Representative.



- 4.12 A statutory declaration referred to in TP4.11 shall, in addition to the depositions described in TP4.9, contain a deposition by the Contractor that all of the Contractor's lawful obligations and any lawful claims against the Contractor that arose out of the performance of the contract have been discharged and satisfied.

TP5 Progress Report and Payment Thereunder Not Binding on Her Majesty

- 5.1 Neither a progress report referred to in TP4.3 nor any payment made by Her Majesty pursuant to these Terms of Payment shall be construed as an admission by Her Majesty that the work, material or any part thereof is complete, is satisfactory or is in accordance with the contract.

TP6 Delay in Making Payment

- 6.1 Notwithstanding GC7 any delay by Her Majesty in making any payment when it is due pursuant to these Terms of Payment shall not be a breach of the contract by Her Majesty.

- 6.2 Her Majesty shall pay, without demand from the Contractor, simple interest at the Bank Rate plus 1 -1/4 per centum on any amount which is overdue pursuant to TP4.1.3, and the interest shall apply from and include the day such amount became overdue until the day prior to the date of payment except that

- 6.2.1 interest shall not be payable or paid unless the amount referred to in TP6.2 has been overdue for more than 15 days following

6.2.1.1 the date the said amount became due and payable, or

6.2.1.2 the receipt by the Departmental Representative of the Statutory Declaration referred to in TP4.5, TP4.8 or TP4.11,

whichever is the later, and

- 6.6.2 interest shall not be payable or paid on overdue advance payments if any.

TP7 Right of Set-off

- 7.1 Without limiting any right of set-off or deduction given or implied by law or elsewhere in the contract, Her Majesty may set off any amount payable to Her Majesty by the Contractor under this contract or under any current contract against any amount payable to the Contractor under this contract.

- 7.2 For the purposes of TP7.1, "current contract" means a contract between Her Majesty and the Contractor

7.2.1 under which the Contractor has an undischarged obligation to perform or supply work, labour or material, or

7.2.2 in respect of which Her Majesty has, since the date of which the Articles of Agreement were made, exercised any right to take the work that is the subject of the contract out of the Contractor's hands.



TP8 Payment in Event of Termination

- 8.1 If the contract is terminated pursuant to GC41, Her Majesty shall pay the Contractor any amount that is lawfully due and payable to the Contractor as soon as is practicable under the circumstances.

TP9 Interest on Settled Claims

- 9.1 Her Majesty shall pay to the Contractor simple interest on the amount of a settled claim at an average Bank Rate plus 1 ¼ per centum from the date the settled claim was outstanding until the day prior to the date of payment.
- 9.2 For the purposes of TP9.1,
- 9.2.1 a claim is deemed to have been settled when an agreement in writing is signed by the Departmental Representative and the Contractor setting out the amount of the claim to be paid by Her Majesty and the items or work for which the said amount is to be paid.
- 9.2.2 an "average Bank Rate" means the discount rate of interest set by the Bank of Canada in effect at the end of each calendar month averaged over the period the settled claim was outstanding.
- 9.2.3 a settled claim is deemed to be outstanding from the day immediately following the date the said claim would have been due and payable under the contract had it not been disputed.
- 9.3 For the purposes of TP9 a claim means a disputed amount subject to negotiation between Her Majesty and the Contractor under the contract.



Section	Page	Heading
GC1	1	Interpretation
GC2	2	Successors and Assigns
GC3	2	Assignment of Contract
GC4	2	Subcontracting by Contractor
GC5	2	Amendments
GC6	3	No Implied Obligations
GC7	3	Time of Essence
GC8	3	Indemnification by Contractor
GC9	3	Indemnification by Her Majesty
GC10	3	Members of House of Commons Not to Benefit
GC11	4	Notices
GC12	4	Material, Plant and Real Property Supplied by Her Majesty
GC13	5	Material, Plant and Real Property Become Property of Her Majesty
GC14	5	Permits and Taxes Payable
GC15	6	Performance of Work under Direction of Departmental Representative
GC16	6	Cooperation with Other Contractors
GC17	7	Examination of Work
GC18	7	Clearing of Site
GC19	7	Contractor's Superintendent
GC20	8	National Security
GC21	8	Unsuitable Workers
GC22	8	Increased or Decreased Costs
GC23	9	Canadian Labour and Material
GC24	9	Protection of Work and Documents
GC25	10	Public Ceremonies and Signs
GC26	10	Precautions against Damage, Infringement of Rights, Fire, and Other Hazards
GC27	11	Insurance
GC28	11	Insurance Proceeds
GC29	12	Contract Security
GC30	12	Changes in the Work
GC31	13	Interpretation of Contract by Departmental Representative
GC32	14	Warranty and Rectification of Defects in Work
GC33	14	Non-Compliance by Contractor
GC34	14	Protesting Departmental Representative's Decisions
GC35	15	Changes in Soil Conditions and Neglect or Delay by Her Majesty
GC36	16	Extension of Time
GC37	16	Assessments and Damages for Late Completion
GC38	17	Taking the Work Out of the Contractor's Hands
GC39	18	Effect of Taking the Work Out of the Contractor's Hands
GC40	18	Suspension of Work by Minister
GC41	19	Termination of Contract
GC42	19	Claims Against and Obligations of the Contractor or Subcontractor
GC43	21	Security Deposit – Forfeiture or Return
GC44	22	Departmental Representative's Certificates
GC45	23	Return of Security Deposit
GC46	24	Clarification of Terms in GC47 to GC50
GC47	24	Additions or Amendments to Unit Price Table
GC48	24	Determination of Cost – Unit Price Table
GC49	25	Determination of Cost – Negotiation
GC50	25	Determination of Cost – Failing Negotiation
GC51	26	Records to be kept by Contractor
GC52	27	Conflict of Interest
GC53	27	Contractor Status



GC1 Interpretation

1.1 In the contract

- 1.1.1 where reference is made to a part of the contract by means of numbers preceded by letters, the reference shall be construed to be a reference to the particular part of the contract that is identified by that combination of letters and numbers and to any other part of the contract referred to therein;
- 1.1.2 “contract” means the contract document referred to in the Articles of Agreement;
- 1.1.3 “contract security” means any security given by the Contractor to Her Majesty in accordance with the contract;
- 1.1.4 “Departmental Representative” means the officer or employee of Her Majesty who is designated pursuant to the Articles of Agreement and includes a person specially authorized by him to perform, on his behalf, any of his functions under the contract and is so designated in writing to the Contractor;
- 1.1.5 “material” includes all commodities, articles and things required to be furnished by or for the Contractor under the contract for incorporation into the work;
- 1.1.6 “Minister” includes a person acting for, or if the office is vacant, in place of the Minister and his successors in the office, and his or their lawful deputy and any of his or their representatives appointed for the purposes of the contract;
- 1.1.7 “person” includes, unless the context otherwise requires, a partnership, proprietorship, firm, joint venture, consortium and a corporation;
- 1.1.8 “plant” includes all animals, tools, implements, machinery, vehicles, buildings, structures, equipment and commodities, articles and things other than material, that are necessary for the due performance of the contract;
- 1.1.9 “subcontractor” means a person to whom the Contractor has, subject to GC4, subcontracted the whole or any part of the work;
- 1.1.10 “superintendent” means the employee of the Contractor who is designated by the Contractor to act pursuant to GC19;
- 1.1.11 “work includes, subject only to any express stipulation in the contract to the contrary, everything that is necessary to be done, furnished or delivered by the Contractor to perform the contract.

1.2 The headings in the contract documents, other than in the Plans and Specifications, form no part of the contract but are inserted for convenience of reference only.

1.3 In interpreting the contract, in the event of discrepancies or conflicts between anything in the Plans and Specifications and the General Conditions, the General Conditions govern.



- 1.4 In interpreting the Plans and Specifications, in the event of discrepancies or conflicts between
- 1.4.1 the Plans and Specifications, the Specifications govern;
 - 1.4.2 the Plans, the Plans drawn with the largest scale govern; and
 - 1.4.3 figured dimensions and scaled dimensions, the figured dimensions govern.

GC2 Successors and Assigns

- 2.1 The contract shall inure to the benefit of and be binding upon the parties hereto and their lawful heirs, executors, administrators, successors and assigns.

GC3 Assignment of Contract

- 3.1 The contract may not be assigned by the Contractor, either in whole or in part, without the written consent of the Minister.

GC4 Subcontracting by Contractor

- 4.1 Subject to this General Condition, the Contractor may subcontract any part of the work.
- 4.2 The Contractor shall notify the Departmental Representative in writing of his intention to subcontract.
- 4.3 A notification referred to in GC4.2 shall identify the part of the work, and the subcontractor with whom it is intended to subcontract.
- 4.4 The Departmental Representative may object to the intended subcontracting by notifying the Contractor in writing within six days of receipt by the Departmental Representative of a notification referred to in GC4.2.
- 4.5 If the Departmental Representative objects to a subcontracting pursuant to GC4.4, the Contractor shall not enter into the intended subcontract.
- 4.6 The contractor shall not, without the written consent of the Departmental Representative, change a subcontractor who has been engaged by him in accordance with this General Condition.
- 4.7 Every subcontract entered into by the Contractor shall adopt all of the terms and conditions of this contract that are of general application.
- 4.8 Neither a subcontracting nor the Departmental Representative's consent to a subcontracting by the Contractor shall be construed to relieve the Contractor from any obligation under the contract or to impose any liability upon Her Majesty.

GC5 Amendments



- 5.1 No amendment or change in any of the provisions of the contract shall have any force or effect until it is reduced to writing.

GC6 No Implied Obligations

- 6.1 No implied terms or obligations of any kind by or on behalf of Her Majesty shall arise from anything in the contract and the express covenants and agreements therein contained and made by Her Majesty are the only covenants and agreements upon which any rights against Her Majesty are to be founded.
- 6.2 The contract supersedes all communications, negotiations and agreements, either written or oral, relating to the work that were made prior to the date of the contract.

GC7 Time of Essence

- 7.1 Time is of the essence of the contract.

GC8 Indemnification by Contractor

- 8.1 The Contractor shall indemnify and save Her Majesty harmless from and against all claims, demand, losses, costs, damages, actions, suits, or proceedings by whomever made, brought or prosecuted and in any manner based upon, arising out of, related to, occasioned by or attributable to the activities of the Contractor, his servants, agents, subcontractors and sub-subcontractors in performing the work including an infringement or an alleged infringement of a patent of invention or any other kind of intellectual property.
- 8.2 For the purpose of GC8.1, "activities" includes any act improperly carried out, any omission to carry out an act and any delay in carrying out an act.

GC9 Indemnification by Her Majesty

- 9.1 Her Majesty shall, subject to the Crown Liability Act, the Patent Act, and any other law that affects Her Majesty's rights, powers, privileges or obligations, indemnify and save the Contractor harmless from and against all claims, demands, losses, costs, damage, actions, suits or proceedings arising out of his activities under the contract that are directly attributable to
- 9.1.1 lack of or a defect in Her Majesty's title to the work site whether real or alleged; or
- 9.1.2 an infringement or an alleged infringement by the Contractor of any patent of invention or any other kind of intellectual property occurring while the Contractor was performing any act for the purposes of the contract employing a model, plan or design or any other thing related to the work that was supplied by Her Majesty to the Contractor.

GC10 Members of House of Commons Not to Benefit



- 10.1 As required by the Parliament of Canada Act, it is an express condition of the contract that no member of the House of Commons shall be admitted to any share of part of the contract or to any benefit arising therefrom.

GC11 Notices

- 11.1 Any notice, consent, order, decision, direction or other communication, other than a notice referred to in GC11.4, that may be given to the Contractor pursuant to the contract may be given in any manner.
- 11.2 Any notice, consent, order, decision, direction or other communication required to be given in writing, to any party pursuant to the contract shall, subject to GC11.4, be deemed to have been effectively given
- 11.2.1 to the Contractor, if delivered personally to the Contractor or the Contractor's superintendent, or forwarded by mail, telex or facsimile to the Contractor at the address set out in A4.1, or
- 11.2.2 to Her Majesty, if delivered personally to the Departmental Representative, or forwarded by mail, telex or facsimile to the Departmental Representative at the address set out in A1.2.1.
- 11.3 Any such notice, consent, order, decision, direction or other communication given in accordance with GC11.2 shall be deemed to have been received by either party
- 11.3.1 if delivered personally, on the day that it was delivered,
- 11.3.2 if forwarded by mail, on the earlier of the day it was received and the sixth day after it was mailed, and
- 11.3.3 if forwarded by telex or facsimile, 24 hours after it was transmitted.
- 11.4 A notice given under GC38.1.1, GC40 and GC41, if delivered personally, shall be delivered to the Contractor if the Contractor is doing business as sole proprietor or, if the Contractor is a partnership or corporation, to an officer thereof.

GC12 Material, Plant and Real Property Supplied by Her Majesty

- 12.1 Subject to GC12.2, the Contractor is liable to Her Majesty for any loss of or damage to material, plant or real property that is supplied or placed in the care, custody and control of the Contractor by Her Majesty for use in connection with the contract, whether or not that loss or damage is attributable to causes beyond the Contractor's control.
- 12.2 The Contractor is not liable to Her Majesty for any loss or damage to material, plant or real property referred to in GC12.1 if that loss or damage results from and is directly attributable to reasonable wear and tear.
- 12.3 The Contractor shall not use any material, plant or real property referred to in GC12.1 except for



the purpose of performing this contract.

- 12.4 When the Contractor fails to make good any loss or damage for which he is liable under GC12.1 within a reasonable time after being required to do so by the Departmental Representative, the Departmental Representative may cause the loss or damage to be made good at the Contractor's expense, and the Contractor shall thereupon be liable to Her Majesty for the cost thereof and shall, on demand, pay to Her Majesty an amount equal to that cost.
- 12.5 The Contractor shall keep such records of all material, plant and real property referred to in GC12.1 as the Departmental Representative from time to time requires and shall satisfy the Departmental Representative, when requested, that such material, plant and real property are at the place and in the condition which they ought to be.

GC13 Material, Plant and Real Property Become Property of Her Majesty

- 13.1 Subject to GC14.7 all material and plant and the interest of the Contractor in all real property, licenses, powers and privileges purchased, used or consumed by the Contractor for the contract shall, after the time of their purchase, use or consumption be the property of Her Majesty for the purposes of the work and they shall continue to be the property of Her Majesty.
- 13.1.1 in the case of material, until the Departmental Representative indicates that he is satisfied that it will not be required for the work, and
- 13.1.2 in the case of plant, real property, licenses, powers and privileges, until the Departmental Representative indicates that he is satisfied that the interest vested in Her Majesty therein is no longer required for the purposes of the work.
- 13.2 Material or plant that is the property of Her Majesty by virtue of GC13.1 shall not be taken away from the work site or used or disposed of except for the purposes of the work without the written consent of the Departmental Representative.
- 13.3 Her Majesty is not liable for loss of or damage from any cause to the material or plant referred to in GC13.1 and the Contractor is liable for such loss or damage notwithstanding that the material or plant is the property of Her Majesty.

GC14 Permits and Taxes Payable

- 14.1 The Contractor shall, within 30 days after the date of the contract, tender to a municipal authority an amount equal to all fees and charges that would be lawfully payable to that municipal authority in respect of building permits as if the work were being performed for a person other than Her Majesty.
- 14.2 Within 10 days of making a tender pursuant to GC14.1, the Contractor shall notify the Departmental Representative of his action and of the amount tendered and whether or not the municipal authority has accepted that amount.
- 14.3 If the municipal authority does not accept the amount tendered pursuant to GC14.1 the Contractor shall pay that amount to Her Majesty within 6 days after the time stipulated in GC14.2.



- 14.4 For the purposes of GC14.1 to GC14.3 “municipal authority” means any authority that would have jurisdiction respecting permission to perform the work if the owner were not Her Majesty.
- 14.5 Notwithstanding the residency of the Contractor, the Contractor shall pay any applicable tax arising from or related to the performance of the work under the contract.
- 14.6 In accordance with the Statutory Declaration referred to in TP4.9, a Contractor who has neither residence nor place of business in the province in which work under the contract is being performed shall provide Her Majesty with proof of registration with the provincial sales tax authorities in the said province.
- 14.7 For the purpose of the payment of any applicable tax or the furnishing of security for the payment of any applicable tax arising from or related to the performance of the work under the contract, the Contractor shall, notwithstanding the fact that all material, plant and interest of the Contractor in all real property, licenses, powers and privileges, have become the property of Her Majesty after the time of purchase, be liable, as a user or consumer, for the payment or for the furnishing of security for the payment of any applicable tax payable, at the time of the use or consumption of that material, plant or interest of the Contractor in accordance with the relevant legislation.

GC15 Performance of Work under Direction of Departmental Representative

- 15.1 The Contractor shall
- 15.1.1 permit the Departmental Representative to have access to the work and its site at all times during the performance of the contract;
 - 15.1.2 furnish the Departmental Representative with such information respecting the performance of the contract as he may require; and
 - 15.1.3 give the Departmental Representative every possible assistance to enable the Departmental Representative to carry out his duty to see that the work is performed in accordance with the contract and to carry out any other duties and exercise any powers specially imposed or conferred on the Departmental Representative under the contract.

CG16 Cooperation with Other Contractors

- 16.1 Where, in the opinion of the Departmental Representative, it is necessary that other contractors or workers with or without plant and material, be sent onto the work or its site, the Contractor shall, to the satisfaction of the Departmental Representative, allow them access and cooperate with them in the carrying out of their duties and obligation.
- 16.2 If
- 16.2.1 the sending onto the work or its site of other contractors or workers pursuant to GC16.1 could not have been reasonably foreseen or anticipated by the Contractor when entering into the contract, and



16.2.2 the Contractor incurs, in the opinion of the Departmental Representative, extra expense in complying with GC16.1, and

16.2.3 The Contractor has given the Departmental Representative written notice of his claim for the extra expense referred to in GC16.2.2 within 30 days of the date that the other contractors or workers were sent onto the work or its site,

Her Majesty shall pay the Contractor the cost, calculated in accordance with GC48 to GC50, of the extra labour, plant and material that was necessarily incurred.

GC17 Examination of Work

17.1 If, at any time after the commencement of the work but prior to the expiry of the warranty or guarantee period, the Departmental Representative has reason to believe that the work or any part thereof has not been performed in accordance with the contract, the Departmental Representative may have that work examined by an expert of his choice.

17.2 If, as a result of an examination of the work referred to in GC17.1, it is established that the work was not performed in accordance with the contract, then, in addition to and without limiting or otherwise affecting any of Her Majesty's rights and remedies under the contract either at law or in equity, the Contractor shall pay Her Majesty, on demand, all reasonable costs and expenses that were incurred by Her Majesty in having that examination performed.

GC18 Clearing of Site

18.1 The Contractor shall maintain the work and its site in a tidy condition and free from the accumulation of waste material and debris, in accordance with any directions of the Departmental Representative.

18.2 Before the issue of an interim certificate referred to in GC44.2, the Contractor shall remove all the plant and material not required for the performance of the remaining work, and all waste material and other debris, and shall cause the work and its site to be clean and suitable for occupancy by Her Majesty's servants, unless otherwise stipulated in the contract.

18.3 Before the issue of a final certificate referred to in GC44.1, the Contractor, shall remove from the work and its site all of the surplus plant and material and any waste material and other debris.

18.4 The Contractor's obligations described in GC18.1 to GC18.3 do not extend to waste material and other debris caused by Her Majesty's servants or contractors and workers referred to in GC16.1.

GC19 Contractor's Superintendent

19.1 The Contractor shall, forthwith upon the award of the contract, designate a superintendent.

19.2 The Contractor shall forthwith notify the Departmental Representative of the name, address and telephone number of a superintendent designate pursuant to GC19.1.



- 19.3 A superintendent designated pursuant to GC19.1 shall be in full charge of the operations of the Contractor in the performance of the work and is authorized to accept any notice, consent, order, direction, decision or other communication on behalf of the Contractor that may be given to the superintendent under the contract.
- 19.4 The Contractor shall, until the work has been completed, keep a competent superintendent at the work site during working hours.
- 19.5 The Contractor shall, upon the request of the Departmental Representative, remove any superintendent who, in the opinion of the Departmental Representative, is incompetent or has been conducting himself improperly and shall forthwith designate another superintendent who is acceptable to the Departmental Representative.
- 19.6 Subject to GC19.5, the Contractor shall not substitute a superintendent without the written consent of the Departmental Representative.
- 19.7 A breach by the Contractor of GC19.6 entitles the Departmental Representative to refuse to issue any certificate referred to in GC44 until the superintendent has returned to the work site or another superintendent who is acceptable to the Departmental Representative has been substituted.

GC20 National Security

- 20.1 If the Minister is of the opinion that the work is of a class or kind that involves the national security, he may order the Contractor
- 20.1.1 to provide him with any information concerning persons employed or to be employed by him for purposes of the contract; and
 - 20.1.2 to remove any person from the work and its site if, in the opinion of the Minister, that person may be a risk to the national security.
- 20.2 The Contractor shall, in all contracts with persons who are to be employed in the performance of the contract, make provision for his performance of any obligation that may be imposed upon him under GC19 to GC21.
- 20.3 The Contractor shall comply with an order of the Minister under GC20.1

GC21 Unsuitable Workers

- 21.1 The Contractor shall, upon the request of the Departmental Representative, remove any person employed by him for purposes of the contract who, in the opinion of the Departmental Representative, is incompetent or has conducted himself improperly, and the Contractor shall not permit a person who has been removed to return to the work site.

GC22 Increased or Decreased Costs



- 22.1 The amount set out in the Articles of Agreement shall not be increased or decreased by reason of any increase or decrease in the cost of the work that is brought about by an increase or decrease in the cost of labour, plant or material or any wage adjustment arising pursuant to the Labour Conditions.
- 22.2 Notwithstanding GC22.1 and GC35, an amount set out in the Articles of Agreement shall be adjusted in the manner provided in GC22.3, if any change in a tax imposed under the Excise Act, the Excise Tax Act, the Old Age Security Act, the Customs Act, the Customs Tariff or any provincial sales tax legislation imposing a retail sales tax on the purchase of tangible personal property incorporated into Real Property
- 22.2.1 occurs after the date of the submission by the Contractor of his tender for the contract,
- 22.2.2 applies to material, and
- 22.2.3 affects the cost to the Contractor of that material.
- 22.3 If a change referred to in GC22.2 occurs, the appropriate amount set out in the Articles of Agreement shall be increased or decreased by an amount equal to the amount that is established by an examination of the relevant records of the Contractor referred to in GC51 to be the increase or decrease in the cost incurred that is directly attributable to that change.
- 22.4 For the purpose of GC22.2, where a tax is changed after the date of submission of the tender but public notice of the change has been given by the Minister of Finance before that date, the change shall be deemed to have occurred before the date of submission of the tender.

GC23 Canadian Labour and Material

- 23.1 The Contractor shall use Canadian labour and material in the performance of the work to the full extent to which they are procurable, consistent with proper economy and expeditious carrying out of the work.
- 23.2 Subject to GC23.1, the Contractor shall, in the performance of the work, employ labour from the locality where the work is being performed to the extent to which it is available, and shall use the offices of the Canada Employment Centres for the recruitment of workers wherever practicable.
- 23.3 Subject to GC23.1 and GC23.2, the Contractor shall, in the performance of the work, employ a reasonable proportion of persons who have been on active service with the armed forces of Canada and have been honourably discharged therefrom.

GC24 Protection of Work and Documents

- 24.1 The Contractor shall guard or otherwise protect the work and its site, and protect the contract, specifications, plans, drawings, information, material, plant and real property, whether or not they are supplied by Her Majesty to the Contractor, against loss or damage from any cause, and he shall not use, issue, disclose or dispose of them without the written consent of the Minister, except as may be essential for the performance of the work.



- 24.2 If any document or information given or disclosed to the Contractor is assigned a security rating by the person who gave or disclosed it, the Contractor shall take all measures directed by the Departmental Representative to be taken to ensure the maintenance of the degree of security that is ascribed to that rating.
- 24.3 The Contractor shall provide all facilities necessary for the purpose of maintaining security, and shall assist any person authorized by the Minister to inspect or to take security measures in respect of the work and its site.
- 24.4 The Departmental Representative may direct the Contractor to do such things and to perform such additional work as the Departmental Representative considers reasonable and necessary to ensure compliance with or to remedy a breach of GC24.1 to GC24.3.

GC25 Public Ceremonies and Signs

- 25.1 The Contractor shall not permit any public ceremony in connection with the work without the prior consent of the Minister.
- 25.2 The Contractor shall not erect or permit the erection of any sign or advertising on the work or its site without the prior consent of the Departmental Representative.

GC26 Precautions against Damage, Infringement of Rights, Fire, and Other Hazards

- 26.1 The Contractor shall, at his own expense, do whatever is necessary to ensure that
- 26.1.1 no person, property, right, easement or privilege is injured, damaged or infringed by reasons of the Contractor's activities in performing the contract;
 - 26.1.2 pedestrian and other traffic on any public or private road or waterway is not unduly impeded, interrupted or endangered by the performance or existence of the work or plant;
 - 26.1.3 fire hazards in or about the work or its site are eliminated and, subject to any direction that may be given by the Departmental Representative, any fire is promptly extinguished;
 - 26.1.4 the health and safety of all persons employed in the performance of the work is not endangered by the method or means of its performance;
 - 26.1.5 adequate medical services are available to all persons employed on the work or its site at all times during the performance of the work;
 - 26.1.6 adequate sanitation measures are taken in respect of the work and its site; and
 - 26.1.7 all stakes, buoys and marks placed on the work or its site by or under the authority of the Departmental Representative are protected and are not removed, defaced, altered or destroyed.
- 26.2 The Departmental Representative may direct the Contractor to do such things and to perform such additional work as the Departmental Representative considers reasonable and necessary to ensure



compliance with or to remedy a breach of GC26.1.

- 26.3 The Contractor shall, at his own expense, comply with a direction of the Departmental Representative made under GC26.2.

GC27 Insurance

- 27.1 The Contractor shall, at his own expense, obtain and maintain insurance contracts in respect of the work and shall provide evidence thereof to the Departmental Representative in accordance with the requirements of the Insurance Conditions "E".

- 27.2 The insurance contracts referred to in GC27.1 shall

27.2.1 be in a form, of the nature, in the amounts, for the periods and containing the terms and conditions specified in Insurance Conditions "E", and

27.2.2 provide for the payment of claims under such insurance contracts in accordance with GC28.

GC28 Insurance Proceeds

- 28.1 In the case of a claim payable under a Builders Risk/Installation (All Risks) insurance contract maintained by the Contractor pursuant to GC27, the proceeds of the claim shall be paid directly to Her Majesty, and

28.1.1 the monies so paid shall be held by Her Majesty for the purposes of the contract, or

28.1.2 if Her Majesty elects, shall be retained by Her Majesty, in which event they vest in Her Majesty absolutely.

- 28.2 In the case of a claim payable under a General Liability insurance contract maintained by the Contractor pursuant to GC27, the proceeds of the claim shall be paid by the insurer directly to the claimant.

- 28.3 If an election is made pursuant to GC28.1, the Minister may cause an audit to be made of the accounts of the Contractor and of Her Majesty in respect of the part of the work that was lost, damaged or destroyed for the purpose of establishing the difference, if any, between

28.3.1 the aggregate of the amount of the loss or damage suffered or sustained by Her Majesty, including any cost incurred in respect of the clearing and cleaning of the work and its site and any other amount that is payable by the Contractor to Her Majesty under the contract, minus any monies retained pursuant to GC28.12, and

28.3.2 the aggregate of the amounts payable by Her Majesty to the Contractor pursuant to the contract up to the date of the loss or damage.

- 28.4 A difference that is established pursuant to GC28.3 shall be paid forthwith by the party who is determined by the audit to be the debtor to the party who is determined by the audit to be the



creditor.

- 28.5 When payment of a deficiency has been made pursuant to GC28.4, all rights and obligations of Her Majesty and the Contractor under the contract shall, with respect only to the part of the work that was the subject of the audit referred to in GC28.3, be deemed to have been expended and discharged.
- 28.6 If an election is not made pursuant to GC28.1.2 the Contractor shall, subject to GC28.7, clear and clean the work and its site and restore and replace the part of the work that was lost, damaged or destroyed at his own expense as if that part of the work had not yet been performed.
- 28.7 When the Contractor clears and cleans the work and its site and restores and replaces the work referred to in GC 28.6, Her Majesty shall pay him out of the monies referred to in GC28.1 so far as they will thereunto extend.
- 28.8 Subject to GC28.7, payment by Her Majesty pursuant to GC28.7 shall be made in accordance with the contract but the amount of each payment shall be 100% of the amount claimed notwithstanding TP4.4.1 and TP4.4.2.

GC29 Contract Security

- 29.1 The Contractor shall obtain and deliver contract security to the Departmental Representative in accordance with the provisions of the Contract Security Conditions.
- 29.2 If the whole or a part of the contract security referred to in GC29.1 is in the form of a security deposit, it shall be held and disposed of in accordance with GC43 and GC45.
- 29.3 If a part of the contract security referred to in GC29.1 is in the form of a labour and material payment bond, the Contractor shall post a copy of that bond on the work site.

GC30 Changes in the Work

- 30.1 Subject to GC5, the Departmental Representative may, at any time before he issues his Final Certificate of Completion,
- 30.1.1 order work or material in addition to that provided for in the Plans and Specifications;
and
- 30.1.2 delete or change the dimensions, character, quantity, quality, description, location or position of the whole or any part of the work or material provided for in the Plans and Specifications or in any order made pursuant to GC30.1.1,
- if that additional work or material, deletion, or change is, in his opinion, consistent with the general intent of the original contract.
- 30.2 The Contractor shall perform the work in accordance with such orders, deletions and changes that are made by the Departmental Representative pursuant to GC30.1 from time to time as if they had appeared in and been part of the Plans and Specifications.



- 30.3 The Departmental Representative shall determine whether or not anything done or omitted by the Contractor pursuant to an order, deletion or change referred to in GC30.1 increased or decreased the cost of the work to the Contractor.
- 30.4 If the Departmental Representative determines pursuant to GC30.3 that the cost of the work to the Contractor has been increased, Her Majesty shall pay the Contractor the increased cost that the Contractor necessarily incurred for the additional work calculated in accordance with GC49 or GC50.
- 30.5 If the Departmental Representative determines pursuant to GC30.3 that the cost of the work to the Contractor has been decreased, Her Majesty shall reduce the amount payable to the Contractor under the contract by an amount equal to the decrease in the cost caused by the deletion or change referred to in GC30.1.2 and calculated in accordance with GC49.
- 30.6 GC30.3 to GC30.5 are applicable only to a contract or a portion of a contract for which a Fixed Price Arrangement is stipulated in the contract.
- 30.7 An order, deletion or change referred to in GC30.1 shall be in writing, signed by the Departmental Representative and given to the Contractor in accordance with GC11.

GC31 Interpretation of Contract by Departmental Representative

- 31.1 If, at any time before the Departmental Representative has issued a Final Certificate of Completion referred to in GC44.1, any question arises between the parties about whether anything has been done as required by the contract or about what the Contractor is required by the contract to do, and, in particular but without limiting the generality of the foregoing, about
- 31.1.1 the meaning of anything in the Plans and Specification,
 - 31.1.2 the meaning to be given to the Plans and Specifications in case of any error therein, omission therefrom, or obscurity or discrepancy in their working or intention,
 - 31.1.3 whether or not the quality or quantity of any material or workmanship supplied or proposed to be supplied by the Contractor meets the requirements of the contract,
 - 31.1.4 whether or not the labour, plant or material provided by the Contractor for performing the work and carrying out the contract are adequate to ensure that the work will be performed in accordance with the contract and that the contract will be carried out in accordance with its terms,
 - 31.1.5 what quantity of any kind of work has been completed by the Contractor, or
 - 31.1.6 the timing and scheduling of the various phases of the performance of the work,
- the question shall be decided by the Departmental Representative whose decision shall be final and conclusive in respect of the work.
- 31.2 The Contractor shall perform the work in accordance with any decisions of the Departmental



Representative that are made under GC31.1 and in accordance with any consequential directions given by the Departmental Representative.

GC32 Warranty and Rectification of Defects in Work

- 32.1 Without restricting any warranty or guarantee implied or imposed by law or contained in the contract documents, the Contractor shall, at his own expense,
- 32.1.1 rectify and make good any defect or fault that appears in the work or comes to the attention of the Minister with respect to those parts of the work accepted in connection with the Interim Certificate of Completion referred to GC44.2 within 12 months from the date of the Interim Certificate of Completion;
- 32.1.2 rectify and make good any defect or fault that appears in or comes to the attention of the Minister in connection with those parts of the work described in the Interim Certificate of Completion referred to in GC44.2 within 12 months from the date of the Final Certificate of Completion referred to in GC44.1.
- 32.2 The Departmental Representative may direct the Contractor to rectify and make good any defect or fault referred to in GC32.1 or covered by any other expressed or implied warranty or guarantee.
- 32.3 A direction referred to in GC32.2 shall be in writing, may include a stipulation in respect of the time within which a defect or fault is required to be rectified and made good by the Contractor, and shall be given to the Contractor in accordance with GC11.
- 32.4 The Contractor shall rectify and make good any defect or fault described in a direction given pursuant to GC32.2 within the time stipulated therein.

GC33 Non-Compliance by Contractor

- 33.1 If the Contractor fails to comply with any decision or direction given by the Departmental Representative pursuant to GC18, GC24, GC26, GC31 or GC32, the Departmental Representative may employ such methods as he deems advisable to do that which the Contractor failed to do.
- 33.2 The Contractor shall, on demand, pay Her Majesty an amount that is equal to the aggregate of all cost, expenses and damage incurred or sustained by Her Majesty by reason of the Contractor's failure to comply with any decision or direction referred to in GC33.1, including the cost of any methods employed by the Departmental Representative pursuant to GC33.1.

GC34 Protesting Departmental Representative's Decisions

- 34.1 The Contractor may, within ten days after the communication to him of any decision or direction referred to in GC30.3 or GC33.1, protest that decision or direction.
- 34.2 A protest referred to in GC34.1 shall be in writing, contain full reasons for the protest, be signed



by the Contractor and be given to Her Majesty by delivery to the Departmental Representative.

- 34.3 If the Contractor gives a protest pursuant to GC34.2, any compliance by the Contractor with the decision or direction that was protested shall not be construed as an admission by the Contractor of the correctness of that decision or direction, or prevent the Contractor from taking whatever action he considers appropriate in the circumstances.
- 34.4 The giving of a protest by the Contractor pursuant to GC34.2 shall not relieve him from complying with the decision or direction that is the subject of the protest.
- 34.5 Subject to GC34.6, the Contractor shall take any action referred to in GC34.3 within three months after the date that a Final Certificate of Completion is issued under GC44.1 and not afterwards.
- 34.6 The Contractor shall take any action referred to in GC34.3 resulting from a direction under GC32 within three months after the expiry of a warranty or guarantee period and not afterwards.
- 34.7 Subject to GC34.8, if Her Majesty determines that the Contractor's protest is justified, Her Majesty shall pay the Contractor the cost of the additional labour, plant and material necessarily incurred by the Contractor in carrying out the protested decision or direction.
- 34.8 Costs referred to in GC34.7 shall be calculated in accordance with GC48 to GC50.

GC35 Changes in Soil Conditions and Neglect or Delay by Her Majesty

- 35.1 Subject to GC35.2 no payment, other than a payment that is expressly stipulated in the contract, shall be made by Her Majesty to the Contractor for any extra expense or any loss or damage incurred or sustained by the Contractor.
- 35.2 If the Contractor incurs or sustains any extra expense or any loss or damage that is directly attributable to
- 35.2.1 a substantial difference between the information relating to soil conditions at the work site that is contained in the Plans and Specifications or other documents supplied to the Contractor for his use in preparing his tender or a reasonable assumption of fact based thereon made by the Contractor, and the actual soil conditions encountered by the Contractor at the work site during the performance of the contract, or
- 35.2.2 any neglect or delay that occurs after the date of the contract on the part of Her Majesty in providing any information or in doing any act that the contract either expressly requires Her Majesty to do or that would ordinarily be done by an owner in accordance with the usage of the trade,

he shall, within ten days of the date the actual soil conditions described in GC35.2.1 were encountered or the neglect or delay described in GC35.2.2 occurred, give the Departmental Representative written notice of his intention to claim for that extra expense or that loss or damage.

- 35.3 When the Contractor has given a notice referred to in GC35.2, he shall give the Departmental Representative a written claim for extra expense or loss or damage within 30 days of the date that



a Final Certificate of Completion referred to in GC44.1 is issued and not afterwards.

- 35.4 A written claim referred to in GC35.3 shall contain a sufficient description of the facts and circumstances of the occurrence that is the subject of the claim to enable the Departmental Representative to determine whether or not the claim is justified and the Contractor shall supply such further and other information for that purpose as the Departmental Representative requires from time to time.
- 35.5 If the Departmental Representative determines that a claim referred to in GC35.3 is justified, Her Majesty shall make an extra payment to the Contractor in an amount that is calculated in accordance with GC47 to GC50.
- 35.6 If, in the opinion of the Departmental Representative, an occurrence described in GC35.2.1 results in a savings of expenditure by the Contractor in performing the contract, the amount set out in the Articles of Agreement shall, subject to GC35.7, be reduced by an amount that is equal to the saving.
- 35.7 The amount of the saving referred to in GC35.6 shall be determined in accordance with GC47 to GC49.
- 35.8 If the Contractor fails to give a notice referred to in GC35.2 and a claim referred to in GC35.3 within the times stipulated, an extra payment shall not be made to him in respect of the occurrence.

GC36 Extension of Time

- 36.1 Subject to GC36.2, the Departmental Representative may, on the application of the Contractor made before the day fixed by the Articles of Agreement for completion of the work or before any other date previously fixed under this General Condition, extend the time for its completion by fixing a new date if, in the opinion of the Departmental Representative, causes beyond the control of the Contractor have delayed its completion.
- 36.2 An application referred to in GC36.1 shall be accompanied by the written consent of the bonding company whose bond forms part of the contract security.

GC37 Assessments and Damages for Late Completion

- 37.1 For the purposes of this General Condition
- 37.1.1 the work shall be deemed to be completed on the date that an Interim Certificate of Completion referred to in GC44.2 is issued, and
- 37.1.2 "period of delay" means the number of days commencing on the day fixed by the Articles of Agreement for completion of the work and ending on the day immediately preceding the day on which the work is completed but does not include any day within a period of extension granted pursuant to GC36.1, and any other day on which, in the opinion of the Departmental Representative, completion of the work was delayed for reasons beyond the control of the Contractor.



- 37.2 If the Contractor does not complete the work by the day fixed for its completion by the Articles of Agreement but completes it thereafter, the Contractor shall pay Her Majesty an amount equal to the aggregate of
- 37.2.1 all salaries, wages and travelling expenses incurred by Her Majesty in respect of persons overseeing the performance of the work during the period of delay;
 - 37.2.2 the cost incurred by Her Majesty as a result of the inability to use the completed work for the period of delay; and
 - 37.2.3 all other expenses and damages incurred or sustained by Her Majesty during the period of delay as a result of the work not being completed by the day fixed for its completion.
- 37.3 The Minister may waive the right of Her Majesty to the whole or any part of the amount payable by the Contractor pursuant to GC37.2 I, in the opinion of the Minister, it is in the public interest to do so.

GC38 Taking the Work Out of the Contractor's Hands

- 38.1 The Minister may, at his sole discretion, by giving a notice in writing to the Contractor in accordance with GC11, take all or any part of the work out of the Contractor's hands, and may employ such means as he sees fit to have the work completed if the Contractor
- 38.1.1 Has not, within six days of the Minister or the Departmental Representative giving notice to the Contractor in writing in accordance with GC11, remedied any delay in the commencement or any default in the diligent performance of the work to the satisfaction of the Departmental Representative;
 - 38.1.2 has defaulted in the completion of any part of the work within the time fixed for its completion by the contract;
 - 38.1.3 has become insolvent;
 - 38.1.4 has committed an act of bankruptcy;
 - 38.1.5 has abandoned the work;
 - 38.1.6 has made an assignment of the contract without the consent required by GC3.1; or
 - 38.1.7 has otherwise failed to observe or perform any of the provisions of the contract.
- 38.2 If the whole or any part of the work is taken out of the Contractor's hands pursuant to GC38.1,
- 38.2.1 the Contractor's right to any further payment that is due or accruing due under the contract is, subject only to GC38.4, extinguished, and
 - 38.2.2 the Contractor is liable to pay Her Majesty, upon demand, an amount that is equal to the amount of all loss and damage incurred or sustained by Her Majesty in respect of the



Contractor's failure to complete the work.

- 38.3 If the whole or any part of the work that is taken out of the Contractor's hands pursuant to GC38.1 is completed by Her Majesty, the Departmental Representative shall determine the amount, if any, of the holdback or a progress claim that had accrued and was due prior to the date on which the work was taken out of the Contractor's hands and that is not required for the purposes of having the work performed or of compensating Her Majesty for any other loss or damage incurred or sustained by reason of the Contractor's default.
- 38.4 Her Majesty may pay the Contractor the amount determined not to be required pursuant to GC38.3.

GC39 Effect of Taking the Work Out of the Contractor's Hands

- 39.1 The taking of the work or any part thereof out of the Contractor's hands pursuant to GC38 does not operate so as to relieve or discharge him from any obligation under the contract or imposed upon him by law except the obligation to complete the performance of that part of the work that was taken out of his hands.
- 39.2 If the work or any part thereof is taken out of the Contractor's hands pursuant to GC38, all plant and material and the interest of the Contractor is all real property, licenses, powers and privileges acquired, used or provided by the Contractor under the contract shall continue to be the property of Her Majesty without compensation to the Contractor.
- 39.3 When the Departmental Representative certifies that any plant, material, or any interest of the Contractor referred to in GC39.2 is no longer required for the purposes of the work, or that it is not in the interest of Her Majesty to retain that plant, material or interest, it shall revert to the Contractor.

G40 Suspension of Work by Minister

- 40.1 The Minister may, when in his opinion it is in the public interest to do so, require the Contractor to suspend performance of the work either for a specified or an unspecified period by giving a notice of suspension in writing to the Contractor in accordance with GC11.
- 40.2 When a notice referred to in GC40.1 is received by the Contractor in accordance with GC11, he shall suspend all operations in respect of the work except those that, in the opinion of the Departmental Representative, are necessary for the care and preservation of the work, plant and material.
- 40.3 The Contractor shall not, during a period of suspension, remove any part of the work, plant or material from its site without the consent of the Departmental Representative.
- 40.4 If a period of suspension is 30 days or less, the Contractor shall, upon the expiration of that period, resume the performance of the work and he is entitled to be paid the extra cost, calculated in accordance with GC48 to GC50, of any labour, plant and material necessarily incurred by him as a result of the suspension.



- 40.5 If, upon the expiration of a period of suspension of more than 30 days, the Minister and the Contractor agree that the performance of the work will be continued by the Contractor, the Contractor shall resume performance of the work subject to any terms and conditions agreed upon by the Minister and the Contractor.
- 40.6 If, upon the expiration of a period of suspension of more than 30 days, the Minister and the Contractor do not agree that performance of the work will be continued by the Contractor or upon the terms and conditions under which the Contractor will continue the work, the notice of suspension shall be deemed to be a notice of termination pursuant to GC41.

GC41 Termination of Contract

- 41.1 The Minister may terminate the contract at any time by giving a notice of termination in writing to the Contractor in accordance with GC11.
- 41.2 When a notice referred to in GC41.1 is received by the Contractor in accordance with GC11, he shall, subject to any conditions stipulated in the notice, forthwith cease all operations in performance of the contract.
- 41.3 If the contract is terminated pursuant to GC41.1, Her Majesty shall pay the Contractor, subject to GC41.4, an amount equal to
- 41.3.1 the cost to the contractor of all labour, plant and material supplied by him under the contract up to the date of termination in respect of a contract or part thereof for which a Unit Price Arrangement is stipulated in the contract, or
 - 41.3.2 the lesser of
 - 41.3.2.1 an amount, calculated in accordance with the Terms and Payment, that would have been payable to the Contractor had he completed the work, and
 - 41.3.2.2 an amount that is determined to be due to the Contractor pursuant to GC49 in respect of a contract or part thereof for which a Fixed Price Arrangement is stipulated in the contract
- less the aggregate of all amounts that were paid to the Contractor by Her Majesty and all amounts that are due to Her Majesty from the Contractor pursuant to the contract.
- 41.4 If Her Majesty and the Contractor are unable to agree about an amount referred to in GC41.3 that amount shall be determined by the method referred to in GC50.

GC42 Claims Against and Obligations of the Contractor or Subcontractor

- 42.1 Her Majesty may, in order to discharge lawful obligations of and satisfy claims against the Contractor or a subcontractor arising out of the performance of the contract, pay any amount that is due and payable to the Contractor pursuant to the contract directly to the obligees of and the claimants against the Contractor or the subcontractor but such amount if any, as is paid by Her Majesty, shall not exceed that amount which the Contractor would have been obliged to pay to



such claimant had the provisions of the Provincial or Territorial lien legislation, or, in the Province of Quebec, the law relating to privileges, been applicable to the work. Any such claimant need not comply with the provisions of such legislation setting out the steps by way of notice, registration or otherwise as might have been necessary to preserve or perfect any claim for lien or privilege which claimant might have had;

- 42.2 Her Majesty will not make any payment as described in GC42.1 unless and until that claimant shall have delivered to Her Majesty:
- 42.2.1 a binding and enforceable Judgment or Order of a court of competent jurisdiction setting forth such amount as would have been payable by the Contractor to the claimant pursuant to the provisions of the applicable Provincial or Territorial lien legislation, or, in the Province of Quebec, the law relating to privileges, had such legislation been applicable to the work; or
 - 42.2.2 a final and enforceable award of an arbitrator setting forth such amount as would have been payable by the Contractor to the claimant pursuant to the provisions of the applicable Provincial or Territorial lien legislation, or, in the Province of Quebec, the law relating to privileges, had such legislation been applicable to the work; or
 - 42.2.3 the consent of the Contractor authorizing a payment.

For the purposes of determining the entitlement of a claimant pursuant to GC42.2.1 and GC42.2.2, the notice required by GC42.8 shall be deemed to replace the registration or provision of notice after the performance of work as required by any applicable legislation and no claim shall be deemed to have expired, become void or unenforceable by reason of the claimant not commencing any action within the time prescribed by any applicable legislation.

- 42.3 The Contractor shall, by the execution of his contract, be deemed to have consented to submit to binding arbitration at the request of any claimant those questions that need be answered to establish the entitlement of the claimant to payment pursuant to the provisions of GC42.1 and such arbitration shall have as parties to it any subcontractor to whom the claimant supplied material, performed work or rented equipment should such subcontractor wish to be adjoined and the Crown shall not be a party to such arbitration and, subject to any agreement between the Contractor and the claimant to the contrary, the arbitration shall be conducted in accordance with the Provincial or Territorial legislation governing arbitration applicable in the Province or Territory in which the work is located.
- 42.4 A payment made pursuant to GC42.1 is, to the extent of the payment, a discharge of Her Majesty's liability to the Contractor under the contract and may be deducted from any amount payable to the Contractor under the contract.
- 42.5 To the extent that the circumstances of the work being performed for Her Majesty permit, the Contractor shall comply with all laws in force in the Province or Territory where the work is being performed relating to payment period, mandatory holdbacks, and creation and enforcement of mechanics' liens, builders' liens or similar legislation or in the Province of Quebec, the law relating to privileges.
- 42.6 The Contractor shall discharge all his lawful obligations and shall satisfy all lawful claims against him arising out of the performance of the work at least as often as the contract requires Her



Majesty to pay the Contractor.

- 42.7 The Contractor shall, whenever requested to do so by the Departmental Representative, make a statutory declaration deposing to the existence and condition of any obligations and claims referred to in GC42.6.
- 42.8 GC42.1 shall only apply to claims and obligations
- 42.8.1 the notification of which has been received by the Departmental Representative in writing before payment is made to the Contractor pursuant to TP4.10 and within 120 days of the date on which the claimant
- 42.8.1.1 should have been paid in full under the claimant's contract with the Contractor or subcontractor where the claim is for money that was lawfully required to be held back from the claimant; or
- 42.8.1.2 performed the last of the services, work or labour, or furnished the last of the material pursuant to the claimant's contract with the Contractor or subcontractor where the claim is not for money referred to in GC42.8.1.1, and
- 42.8.2 the proceedings to determine the right to payment of which, pursuant to GC42.2. shall have commenced within one year from the date that the notice referred to in GC42.8.1 was received by the Departmental Representative, and
- the notification required by GC42.8.1 shall set forth the amount claimed to be owing and the person who by contract is primarily liable.
- 42.9 Her Majesty may, upon receipt of a notice of claim under GC42.8.1, withhold from any amount that is due and payable to the Contractor pursuant to the contract the full amount of the claim or any portion thereof.
- 42.10 The Departmental Representative shall notify the Contractor in writing of receipt of any claim referred to in GC42.8.1 and of the intention of Her Majesty to withhold funds pursuant to GC42.9 and the Contractor may, at any time thereafter and until payment is made to the claimant, be entitled to post, with Her Majesty, security in a form acceptable to Her Majesty in an amount equal to the value of the claim, the notice of which is received by the Departmental Representative and upon receipt of such security Her Majesty shall release to the Contractor any funds which would be otherwise payable to the Contractor, that were withheld pursuant to the provisions of GC42.9 in respect of the claim of any claimant for whom the security stands.

GC43 Security Deposit – Forfeiture or Return

- 43.1 If
- 43.1.1 the work is taken out of the Contractor's hands pursuant to GC38,
- 43.1.2 the contract is terminated pursuant to GC41, or
- 43.1.3 the Contractor is in breach of or in default under the contract,



Her Majesty may convert the security deposit, if any, to Her own use.

- 43.2 If Her Majesty converts the contract security pursuant to GC43.1, the amount realized shall be deemed to be an amount due from Her Majesty to the Contractor under the contract.
- 43.3 Any balance of an amount referred to in GC43.2 that remains after payment of all losses, damage and claims of Her Majesty and others shall be paid by Her Majesty to the Contractor if, in the opinion of the Departmental Representative, it is not required for the purposes of the contract.

GC44 Departmental Representative's Certificates

44.1 On the date that

44.1.1 the work has been completed, and

44.1.2 the Contractor has complied with the contract and all orders and directions made pursuant thereto,

both to the satisfaction of the Departmental Representative, the Departmental Representative shall issue a Final Certificate of Completion to the Contractor.

44.2 If the Departmental Representative is satisfied that the work is substantially complete he shall, at any time before he issues a certificate referred to in GC44.1, issue an Interim Certificate of Completion to the Contractor, and

44.2.1 for the purposes of GC44.2 the work will be considered to be substantially complete,

44.2.1.1 when the work under the contract or a substantial part thereof is, in the opinion of the Departmental Representative, ready for use by Her Majesty or is being used for the purpose intended; and

44.2.1.2 when the work remaining to be done under the contract is, in the opinion of the Departmental Representative, capable of completion or correction at accost of not more than

44.2.1.2.1 -3% of the first \$500,000, and

44.2.1.2.2 -2% of the next \$500,000, and

44.2.1.2.3 -1% of the balance

of the value of the contract at the time this cost is calculated.

44.3 For the sole purpose of GC44.2.1.2, where the work or a substantial part thereof is ready for use or is being used for the purposes intended and the remainder of the work or a part thereof cannot be completed by the time specified in A2.1, or as amended pursuant to GC36, for reasons beyond the control of the Contractor or where the Departmental Representative and the Contractor agree not to complete a part of the work within the specified time, the cost of that part of the work



which was either beyond the control of the Contractor to complete or the Departmental Representative and the Contractor have agreed not to complete by the time specified shall be deducted from the value of the contract referred to GC44.2.1.2 and the said cost shall not form part of the cost of the work remaining to be done in determining substantial completion.

44.4 An Interim Certificate of Completion referred to in GC44.2 shall describe the parts of the work not completed to the satisfaction of the Departmental Representative and all things that must be done by the Contractor

44.4.1 before a Final Certificate of Completion referred to in GC44.1 will be issued, and

44.4.2 before the 12-month period referred to in GC32.1.2 shall commence for the said parts and all the said things.

44.5 The Departmental Representative may, in addition to the parts of the work described in an Interim Certificate of Completion referred to in GC44.2, require the Contractor to rectify any other parts of the work not completed to his satisfaction and to do any other things that are necessary for the satisfactory completion of the work.

44.6 If the contract or a part thereof is subject to a Unit Price Arrangement, the Departmental Representative shall measure and record the quantities of labour, plant and material, performed, used and supplied by the Contractor in performing the work and shall, at the request of the Contractor, inform him of those measurements.

44.7 The Contractor shall assist and co-operate with the Departmental Representative in the performance of his duties referred to in GC44.6 and shall be entitled to inspect any record made by the Departmental Representative pursuant to GC44.6.

44.8 After the Departmental Representative has issued a Final Certificate of Completion referred to in GC44.1, he shall, if GC44.6 applies, issue a Final Certificate of Measurement.

44.9 A Final Certificate of Measurement referred to in GC44.8 shall

44.9.1 contain the aggregate of all measurements of quantities referred to in GC44.6, and

44.9.2 be binding upon and conclusive between Her Majesty and the Contractor as to the quantities referred to therein.

GC45 Return of Security Deposit

45.1 After an Interim Certificate of Completion referred to in GC44.2 has been issued, Her Majesty shall, if the Contractor is not in breach of or in default under the contract, return to the Contractor all or any part of the security deposit that, in the opinion of the Departmental Representative, is not required for the purposes of the contract.

45.2 After a Final Certificate of Completion referred to in GC44.1 has been issued, Her Majesty shall return to the Contractor the remainder of any security deposit unless the contract stipulates otherwise.



- 45.3 If the security deposit was paid into the Consolidated Revenue Fund of Canada, Her Majesty shall pay interest thereon to the Contractor at a rate established from time to time pursuant to section 21(2) of the Financial Administration Act.

GC46 Clarification of Terms in GC47 to GC50

- 46.1 For the purposes of GC47 to GC50,
- 46.1.1 "Unit Price Table" means the table set out in the Articles of Agreement, and
- 46.1.2 "plant" does not include tools customarily provided by a tradesman in practicing his trade.

GC47 Additions or Amendments to Unit Price Table

- 47.1 Where a Unit Price Arrangement applies to the contract or a part thereof the Departmental Representative and the Contractor may, by an agreement in writing,
- 47.1.1 add classes of labour or material, and units of measurement, prices per unit and estimated quantities to the Unit Price Table if any labour, plant or material that is to be included in the Final Certificate of Measurement referred to in GC44.8 is not included in any class of labour, plant or material set out in the Unit Price Table; or
- 47.1.2 subject to GC47.2 and GC47.3, amend a price set out in the Unit Price Table for any class of labour, plant or material included therein if the Final Certificate of Measurement referred to in GC44.8 shows or is expected to show that the total quantity of that class of labour, plant or material actually performed, used or supplied by the Contractor in performing the work is
- 47.1.2.1 less than 85% of that estimated total quantity, or
- 47.1.2.2 in excess of 115% of that estimated total quantity.
- 47.2 In no event shall the total cost of an item set out in the Unit Price Table that has been amended pursuant to GC47.1.2.1 exceed the amount that would have been payable to the Contractor had the estimated total quantity actually been performed, used or supplied.
- 47.3 An amendment that is made necessary by GC47.1.2.2 shall apply only to the quantities that are in excess of 115%.
- 47.4 If the Departmental Representative and the Contractor do not agree as contemplated in GC47.1, the Departmental Representative shall determine the class and the unit of measurement of the labour, plant or material and, subject to GC47.2 and GC47.3, the price per unit therefore shall be determined in accordance with GC50.

GC48 Determination of Cost – Unit Price Table



- 48.1 Whenever, for the purposes of the contract, it is necessary to determine the cost of labour, plant or material, it shall be determined by multiplying the quantity of that labour, plant or material expressed in the unit set out in column 3 of the Unit Price Table by the price of that unit set out in column 5 of the Unit Price Table.

GC49 Determination of Cost – Negotiation

- 49.1 If the method described in GC48 cannot be used because the labour, plant or material is of a kind or class that is not set out in the Unit Price Table, the cost of that labour, plant or material for the purposes of the contract shall be the amount agreed upon from time to time by the Contractor and the Departmental Representative.
- 49.2 For the purposes of GC49.1, the Contractor shall submit to the Departmental Representative any necessary cost information requested by the Departmental Representative in respect of the labour, plant and material referred to in GC49.1

GC50 Determination of Cost – Failing Negotiation

- 50.1 If the methods described in GC47, GC48 or GC49 fail for any reason to achieve a determination of the cost of labour, plant and material for the purposes referred to therein, that cost shall be equal to the aggregate of
- 50.1.1 all reasonable and proper amounts actually expended or legally payable by the Contractor in respect of the labour, plant and material that falls within one of the classes of expenditure described in GC50.2 that are directly attributable to the performance of the contract,
 - 50.1.2 an allowance for profit and all other expenditures or costs, including overhead, general administration cost, financing and interest charges, and every other cost, charge and expenses, but not including those referred to in GC50.1.1 or GC50.1.3 or a class referred to in GC50.2, in an amount that is equal to 10% of the sum of the expenses referred to in GC50.1.1, and
 - 50.1.3 interest on the cost determined under GC50.1.1 and GC50.1.2, which interest shall be calculated in accordance with TP9,

provide that the total cost of an item set out in the Unit Price Table that is subject to the provisions of GC47.1.2.1 does not exceed the amount that would have been payable to the Contractor had the estimated total quantity of the said item actually be performed, used or supplied.

- 50.2 For purposes of GC50.1.1 the classes of expenditure that may be taken into account in determining the cost of labour, plant and material are,
- 50.2.1 payments to subcontractors;
 - 50.2.2 wages, salaries and travelling expenses of employees of the Contractor while they are actually and properly engaged on the work, other than wages, salaries, bonuses, living



and travelling expenses of personnel of the Contractor generally employed at the head office or at a general office of the Contractor unless they are engaged at the work site with the approval of the Departmental Representative,

- 50.2.3 assessments payable under any statutory authority relating to workmen's compensation, unemployment insurance, pension plan or holidays with pay;
- 50.2.4 rent that is paid for plant or an amount equivalent of the said rent if the plant is owned by the Contractor that is necessary for and used in the performance of the work, if the rent of the equivalent amount is reasonable and use of that plant has been approved by the Departmental Representative;
- 50.2.5 payments for maintaining and operating plant necessary for and used in the performance of the work, and payments for effecting such repairs thereto as, in the opinion of the Departmental Representative, are necessary to the proper performance of the contract other than payments for any repairs to the plant arising out of defects existing before its allocation to the work;
- 50.2.6 payments for material that is necessary for and incorporated in the work, or that is necessary for and consumed in the performance of the contract;
- 50.2.7 payments for preparation, delivery, handling, erection, installation, inspection protection and removal of the plant and material necessary for and used in the performance of the contract; and
- 50.2.8 any other payments made by the Contractor with the approval of the Departmental Representative that are necessary for the performance of the contract.

GC51 Records to be kept by Contractor

51.1 The Contractor shall

- 51.1.1 maintain full records of his estimated and actual cost of the work together with all tender calls, quotations, contracts, correspondence, invoices, receipts and vouchers relating thereto.
- 51.1.2 make all records and material referred to in GC5.1.1 available to audit and inspection by the Minister and the Deputy Receiver General for Canada or by persons acting on behalf of either of both of them, when requested;
- 51.1.3 allow any of the person referred to in GC51.1.2 to make copies of and to take extracts from any of the records and material referred to in GC51.1.1; and
- 51.1.4 furnish any person referred to in GC51.1.2 with any information he may require from time to time in connection with such records and material.

- 51.2 The records maintained by the Contractor pursuant to GC51.1.1 shall be kept intact by the Contractor until the expiration of two years after the date that a Final Certificate of Completion referred to in GC44.1 was issued or until the expiration of such other period of time as the



Minister may direct.

- 51.3 The Contractor shall cause all subcontractors and all other persons directly or indirectly controlled by or affiliated with the Contractor and all persons directly or indirectly having control of the Contractor to comply with GC51.1 and GC51.2 as if they were the Contractor.

GC52 Conflict of Interest

- 52.1 It is a term of this contract that no former public office holder who is not in compliance with the Conflict of Interest and Post-Employment Code for Public Office Holders shall derive a direct benefit from this contract.

GC53 Contractor Status

- 53.1 The Contractor shall be engaged under the contract as an independent contractor.
- 53.2 The Contractor and any employee of the said Contractor is not engaged by the contract as an employee, servant or agent of Her Majesty.
- 53.3 For the purposes of GC53.1 and GC53.2 the Contractor shall be solely responsible for any and all payments and deductions required to be made by law including those required for Canada or Quebec Pension Plans, Unemployment Insurance, Worker's Compensation or Income Tax.



GENERAL CONDITONS

- IC 1 Proof of Insurance**
- IC 2 Risk Management**
- IC 3 Payment of Deductible**
- IC 4 Insurance Coverage**

GENERAL INSUANCE COVERAGES

- GCI 1 Insured**
- GIC 2 Period of Insurance**
- GIC 3 Proof of Insurance**
- GIC 4 Notification**

COMMERCIAL GENERAL LIABILITY

- CGL 1 Scope of Policy**
- CGL 2 Coverages/Provisions**
- CGL 3 Additional Exposures**
- CGL 4 Insurance Proceeds**
- CGL 5 Deductible**

BUILDER'S RISK – INSTALLATION FLOATER – ALL RISKS

- BR 1 Scope of Policy**
- BR 2 Property Insured**
- BR 3 Insurance Proceeds**
- BR 4 Amount of Insurance**
- BR 5 Deductible**
- BR 6 Subrogation**
- BR 7 Exclusion Qualifications**

INSURER'S CERTIFICATE OF INSURANCE



General Conditions

IC 1 Proof of Insurance (02/12/03)

Within thirty (30) days after acceptance of the Contractor's tender, the Contractor shall, unless otherwise directed in writing by the Contracting Officer, deposit with the Contracting Officer an Insurer's Certificate of Insurance in the form displayed in this document and, if requested by the Contracting Officer, the originals or certified true copies of all contracts of insurance maintained by the Contractor pursuant to the Insurance Coverage Requirements shown hereunder.

IC 2 Risk Management (01/10/94)

The provisions of the Insurance Coverage Requirements contained hereunder are not intended to cover all of the Contractor's obligations under GC8 of the General Conditions "C" of the contract. Any additional risk management measures or additional insurance coverages the Contractor may deem necessary to fulfill its obligations under GC8 shall be at its own discretion and expense.

IC 3 Payment of Deductible (01/10/94)

The payment of monies up to the deductible amount made in satisfaction of a claim shall be borne by the Contractor.

IC 4 Insurance Coverage (02/12/03)

The Contractor has represented that it has in place and effect the appropriate and usual liability insurance coverage as required by these Insurance Conditions and the Contractor has warranted that it shall obtain, in a timely manner and prior to commencement of the Work, the appropriate and usual property insurance coverage as required by these Insurance Conditions and, further, that it shall maintain all required insurance policies in place and effect as required by these Insurance Conditions.



INSURANCE COVERAGE REQUIREMENTS

PART I GENERAL INSURANCE COVERAGES (GIC)

GCI 1 Insured (02/12/03)

Each insurance policy shall insure the Contractor, and shall include, as an Additional Named Insured, Her Majesty the Queen in right of Canada, represented by the National Research Council Canada.

GIC 2 Period of Insurance (02/12/03)

Unless otherwise directed in writing by the Contracting Officer or otherwise stipulated elsewhere in these Insurance Conditions, the policies required hereunder shall be in force and be maintained from the date of the contract award until the day of issue of the Departmental Representative's Final Certificate of Completion.

GIC 3 Proof of Insurance (01/10/94)

Within twenty five (25) days after acceptance of the Contractor's tender, the Insurer shall, unless otherwise directed by the Contractor, deposit with the Contractor an Insurer's Certificate of Insurance in the form displayed in the document and, if requested, the originals or certified true copies of all contracts of insurance maintained by the Contractor pursuant to the requirements of these Insurance Coverages.

GIC 4 Notification (01/10/94)

Each Insurance policy shall contain a provision that (30) days prior written notice shall be given by the Insurer to Her Majesty in the event of any material change in or cancellation of coverage. Any such notice received by the Contractor shall be transmitted forthwith to Her Majesty.

PART II COMMERCIAL GENERAL LIABILITY

CGL 1 Scope of Policy (01/10/94)

The policy shall be written on a form similar to that known and referred to in the insurance industry as IBC 2100 – Commercial General Liability policy (Occurrence form) and shall provide for limit of liability of not less than \$2,000,000 inclusive for Bodily Injury and Property Damage for any one occurrence or series of occurrences arising out of one cause. Legal or defence cost incurred in respect of a claim or claims shall not operate to decrease the limit of liability.

CGL 2 Coverages/Provisions (01/10/94)



The policy shall include but not necessarily be limited to the following coverages/provisions.

- 2.1 Liability arising out of or resulting from the ownership, existence, maintenance or use of premises by the Contractor and operations necessary or incidental to the performance of this contract.
- 2.2 "Broad Form" Property Damage including the loss of use of property.
- 2.3 Removal or weakening of support of any building or land whether such support be natural or otherwise.
- 2.4 Elevator liability (including escalators, hoists and similar devices).
- 2.5 Contractor's Protective Liability
- 2.6 Contractual and Assumed Liabilities un this contact.
- 2.7 Completed Operations Liability – The insurance, including all aspects of this Part II of these Insurance Conditions shall continue for a period of at least one (1) year beyond the date of the Departmental Representative's Final Certificate of Completion for the Completed Operations.
- 2.8 Cross Liability – The Clause shall be written as follows:

Cross Liability – The insurance as is afforded by this policy shall apply in respect to any claim or action brought against any one Insured by any other Insured. The coverage shall apply in the same manner and to the same extent as though a separate policy had been issued to each Insured. The inclusion herein of more than one Insured shall not increase the limit of the Insurer's liability.

- 2.9 Severability of Interests – The Clause shall be written as follows:

Severability of Interests – This policy, subject to the limits of liability stated herein, shall apply separately to each Insured in the same manner and to the same extent as if a separate policy had been issued to each. The inclusion herein of more than one insured shall not increase the limit of the Insurer's liability.

CGL 3 Additional Exposures (02/12/03)

The policy shall either include or be endorsed to include the following exposures of hazards if the Work is subject thereto:

- 3.1 Blasting
- 3.2 Pile driving and calsson work
- 3.3 Underpinning
- 3.4 Risks associated with the activities of the Contractor on an active airport



- 3.5 Radioactive contamination resulting from the use of commercial isotopes
- 3.6 Damage to the portion of an existing building beyond that directly associated with an addition, renovation or installation contract.
- 3.7 Marine risks associated with the contraction of piers, wharves and docks.

**CGL 4 Insurance Proceeds
(01/10/94)**

Insurance Proceeds from this policy are usually payable directly to a Claimant/Third Party.

**CGL 5 Deductible
(02/12/03)**

This policy shall be issued with a deductible amount of not more than \$10,000 per occurrence applying to Property Damage claims only.

**PART III
BUILDER'S RISK – INSTALLATION FLOATER – ALL RISKS**

**BR 1 Scope of Policy
(01/10/94)**

The policy shall be written on an "All Risks" basis granting coverages similar to those provided by the forms known and referred to in the insurance industry as "Builder's Risk Comprehensive Form" or "Installation Floater – All Risks".

**BR 2 Property Insured
(01/10/94)**

The property insured shall include:

- 2.1 The Work and all property, equipment and materials intended to become part of the finished Work at the site of the project while awaiting, during and after installation, erection or construction including testing.
- 2.2 Expenses incurred in the removal from the construction site of debris of the property insured, including demolition of damaged property, de-icing and dewatering, occasioned by loss, destruction or damage to such property and in respect of which insurance is provided by this policy.

**BR 3 Insurance Proceeds
(01/10/94)**

- 3.1 Insurance proceeds from this policy are payable in accordance with GC28 of the General Conditions "C" of the contract.
- 3.2 This policy shall provide that the proceeds thereof are payable to Her Majesty or as the Minister may direct.



- 3.3 The Contractor shall do such things and execute such documents as are necessary to effect payment of the proceeds.

BR 4 Amount of Insurance
(01/10/94)

The amount of insurance shall not be less than the sum of the contract value plus the declared value (if any) set forth in the contract documents of all material and equipment supplied by Her Majesty at the site of the project to be incorporated into and form part of the finished Work.

BR 5 Deductible
(02/12/03)

The Policy shall be issued with a deductible amount of not more than \$10,000.

BR 6 Subrogation
(01/10/94)

The following Clause shall be included in the policy:

"All rights of subrogation or transfer of rights are hereby waived against any corporation, firm, individual or other interest, with respect to which, insurance is provided by this policy".

BR 7 Exclusion Qualifications
(01/10/94)

The policy may be subject to the standard exclusions but the following qualifications shall apply:

- 7.1 Faulty materials, workmanship or design may be excluded only to the extent of the cost of making good thereof and shall not apply to loss or damage resulting therefrom.
- 7.2 Loss or damage caused by contamination by radioactive material may be excluded except for loss or damage resulting from commercial isotopes used for industrial measurements, inspection, quality control radiographic or photographic use.
- 7.3 Use and occupancy of the project or any part of section thereof shall be permitted where such use and occupancy is for the purpose for which the project is intended upon completion.



INSURER'S CERTIFICATE OF INSURANCE

(TO BE COMPLETED BY INSURER (NOT BOKER) AND DELIVERD TO NATIONAL RESEARCH COUNCIL CANADA WITH 30 DAYS FOLLOWING ACCEPTANCE OF TENDER)

CONTRACT

DESCRIPTION OF WORK	CONTRACT NUMBER	AWARD DATE
LOCATION		

INSURER

NAME
ADDRESS

BROKER

NAME
ADDRESS

INSURED

NAME OF CONTRACTOR
ADDRESS

ADDITIONAL INSURED

HER MAJESTY THE QUEEN IN RIGHT OF CANADA AS REPRESENTED BY THE NATIONAL RESEARCH COUNCIL CANADA

THIS DOCUENT CERTIFIES THAT THE FOLLOWING POLICES OF INSURANCE ARE AT PRESENT IN FORCE COVERING ALL OPERATIONS OF THE INSURE IN CONNECTION WITH THE CONTRACT MADE BETWEEN THE NAMED INSURED AND THE NATIONAL RESEARCH COUNCIL CANADA AND IN ACCORDANCE WITH THE INSURANCE CONDITIONS "E"

POLICY					
TYPE	NUMBER	INCEPTION DATE	EXPIRY DATE	LIMITS OF LIABILITY	DEDUCTIBLE
COMMERCIAL GENERAL LIABILITY					
BUILDERS RISK "AL RISKS"					
INSTALLATION FLOATER "ALL RISKS"					

THE INSURER AGREES TO NOTIFY THE NATIONAL RESEARCH COUNCIL CANADA IN WRITING 30 DAYS PRIOR TO ANY MATERIAL CHANGE IN OR CANCELLATION OF ANY POLICY OR COVERAGE SPECIFICALLY RELATED TO THE CONTRACT

NAME OF INSURER'S OFFICER OR AUTHORIZED EMPLOYEE	SIGNATURE	DATE:
		TELEPHONE NUMBER:

ISSUANCE OF THIS CERTIFIATE SHALL NOT LIMIT OR RESTRICT THE RIGHT OF THE NATIONAL RESEARCH COUNCIL CANADA TO REQUEST AT ANY TIME DUPLICATE COPIES OF SAID INSURANCE POLICIES



CS1 Obligation to provide Contract Security

- 1.1 The Contractor shall, at the Contractor's own expense, provide one or more of the forms of contract security prescribed in CS2.
- 1.2 The Contractor shall deliver to the Departmental Representative the contract security referred to in CS1.1 within 14 days after the date that the Contractor receives notice that the Contractor's tender or offer was accepted by Her Majesty.

CS2 Prescribed Types and Amounts of Contract Security

- 2.1 The Contractor shall deliver to the Departmental Representative pursuant to CS1
 - 2.1.1 a performance bond and a labour and material payment bond each in an amount that is equal to not less than 50% of the contract amount referred to in the Articles of Agreement, or
 - 2.1.2 a labour and material payment bond in an amount that is equal to not less than 50% of the contract amount referred to in the Articles of Agreement, and a security deposit in an amount that is equal to
 - 2.1.2.1 not less than 10% of the contract amount referred to in the Articles of Agreement where that amount does not exceed \$250,000, or
 - 2.1.2.2 \$25,000 plus 5% of the part of the contract amount referred to in the Articles of Agreement that exceeds \$250,000, or
 - 2.1.3 a security deposit in an amount prescribed by CS2.1.2 plus an additional amount that is equal to 10% of the contract amount referred to in the Articles of Agreement.
- 2.2 A performance bond and a labour and material payment bond referred to in CS2.1 shall be in a form and be issued by a bonding or surety company that is approved by Her Majesty.
- 2.3 The amount of a security deposit referred to in CS2.1.2 shall not exceed \$250,000 regardless of the contract amount referred to in the Articles of Agreement.
- 2.4 A security deposit referred to in CS2.1.2 and CS2.1.3 shall be in the form of
 - 2.4.1 a bill of exchange made payable to the Receiver General of Canada and certified by an approved financial institution or drawn by an approved financial institution on itself, or
 - 2.4.2 bonds of or unconditionally guaranteed as to principal and interest by the Government of Canada.
- 2.5 For the purposes of CS2.4
 - 2.5.1 a bill of exchange is an unconditional order in writing signed by the Contractor and addressed to an approved financial institution, requiring the said institution to pay, on demand, at a fixed or determinable future time a sum certain of money to, or to the order



of, the Receiver General for Canada, and

- 2.5.2 If a bill of exchange is certified by a financial institution other than a chartered bank then it must be accompanied by a letter or stamped certification confirming that the financial institution is in at least one of the categories referred to in CS2.5.3
- 2.5.3 an approved financial institution is
 - 2.5.3.1 any corporation or institution that is a member of the Canadian Payments Association,
 - 2.5.3.2 a corporation that accepts deposits that are insured by the Canada Deposit Insurance Corporation or the Régie de l'assurance-dépôts du Québec to the maximum permitted by law,
 - 2.5.3.3 a credit union as defined in paragraph 137(6)(b) of the *Income Tax Act*,
 - 2.5.3.4 a corporation that accepts deposits from the public, if repayment of the deposit is guaranteed by Her Majesty in right of a province, or
 - 2.5.3.5 The Canada Post Corporation.
- 2.5.4 the bonds referred to in CS2.4.2 shall be
 - 2.5.4.1 made payable to bearer, or
 - 2.5.4.2 accompanied by a duly executed instrument of transfer of the bonds to the Receiver General for Canada in the form prescribed by the Domestic Bonds of Canada Regulations, or
 - 2.5.4.3 registered, as to principal or as to principal and interest in the name of the Receiver General for Canada pursuant to the Domestic Bonds of Canada Regulations, and
 - 2.5.4.4 provided on the basis of their market value current at the date of the contract.



Contract Number / Numéro du contrat
Security Classification / Classification de sécurité

**SECURITY REQUIREMENTS CHECK LIST (SRCL)
LISTE DE VÉRIFICATION DES EXIGENCES RELATIVES À LA SÉCURITÉ (LVERS)**

PART A - CONTRACT INFORMATION / PARTIE A - INFORMATION CONTRACTUELLE		
1. Originating Government Department or Organization / Ministère ou organisme gouvernemental d'origine National Research Council	2. Branch or Directorate / Direction générale ou Direction ASPM/SAGI	
3. a) Subcontract Number / Numéro du contrat de sous-traitance	3. b) Name and Address of Subcontractor / Nom et adresse du sous-traitant	
4. Brief Description of Work / Brève description du travail The work is to construct a new oxygen generation system in building M50. Contractor shall provide a new compressed air system, oxygen generator, electrical system, and room ventilation system as per the drawings and specifications. /Le travail consiste à construire un nouveau système de génération d'oxygène dans l'immeuble M-50. L'entrepreneur doit fournir un nouveau système d'air comprimé, générateur d'oxygène, le système électrique et le système de ventilation de pièce selon les plans et devis.		
5. a) Will the supplier require access to Controlled Goods? / Le fournisseur aura-t-il accès à des marchandises contrôlées?	<input checked="" type="checkbox"/> No / Non <input type="checkbox"/> Yes / Oui	
5. b) Will the supplier require access to unclassified military technical data subject to the provisions of the Technical Data Control Regulations? / Le fournisseur aura-t-il accès à des données techniques militaires non classifiées qui sont assujetties aux dispositions du Règlement sur le contrôle des données techniques?	<input checked="" type="checkbox"/> No / Non <input type="checkbox"/> Yes / Oui	
6. Indicate the type of access required / Indiquer le type d'accès requis		
6. a) Will the supplier and its employees require access to PROTECTED and/or CLASSIFIED information or assets? (Specify the level of access using the chart in Question 7. c) / Le fournisseur ainsi que les employés auront-ils accès à des renseignements ou à des biens PROTÉGÉS et/ou CLASSIFIÉS? (Préciser le niveau d'accès en utilisant le tableau qui se trouve à la question 7. c)	<input checked="" type="checkbox"/> No / Non <input type="checkbox"/> Yes / Oui	
6. b) Will the supplier and its employees (e.g. cleaners, maintenance personnel) require access to restricted access areas? No access to PROTECTED and/or CLASSIFIED information or assets is permitted. / Le fournisseur et ses employés (p. ex. nettoyeurs, personnel d'entretien) auront-ils accès à des zones d'accès restreintes? L'accès à des renseignements ou à des biens PROTÉGÉS et/ou CLASSIFIÉS n'est pas autorisé.	<input type="checkbox"/> No / Non <input checked="" type="checkbox"/> Yes / Oui	
6. c) Is this a commercial courier or delivery requirement with no overnight storage? / S'agit-il d'un contrat de messagerie ou de livraison commerciale sans entreposage de nuit?	<input checked="" type="checkbox"/> No / Non <input type="checkbox"/> Yes / Oui	
7. a) Indicate the type of information that the supplier will be required to access / Indiquer le type d'information auquel le fournisseur devra avoir accès		
Canada <input checked="" type="checkbox"/>	NATO / OTAN <input type="checkbox"/>	Foreign / Étranger <input type="checkbox"/>
7. b) Release restrictions / Restrictions relatives à la diffusion		
No release restrictions / Aucune restriction relative à la diffusion <input checked="" type="checkbox"/>	All NATO countries / Tous les pays de l'OTAN <input type="checkbox"/>	No release restrictions / Aucune restriction relative à la diffusion <input type="checkbox"/>
Not releasable / À ne pas diffuser <input type="checkbox"/>		
Restricted to: / Limité à: Specify country(ies): / Préciser le(s) pays: <input type="checkbox"/>	Restricted to: / Limité à: Specify country(ies): / Préciser le(s) pays: <input type="checkbox"/>	Restricted to: / Limité à: Specify country(ies): / Préciser le(s) pays: <input type="checkbox"/>
7. c) Level of information / Niveau d'information		
PROTECTED A / PROTÉGÉ A <input type="checkbox"/>	NATO UNCLASSIFIED / NATO NON CLASSIFIÉ <input type="checkbox"/>	PROTECTED A / PROTÉGÉ A <input type="checkbox"/>
PROTECTED B / PROTÉGÉ B <input type="checkbox"/>	NATO RESTRICTED / NATO DIFFUSION RESTREINTE <input type="checkbox"/>	PROTECTED B / PROTÉGÉ B <input type="checkbox"/>
PROTECTED C / PROTÉGÉ C <input type="checkbox"/>	NATO CONFIDENTIAL / NATO CONFIDENTIEL <input type="checkbox"/>	PROTECTED C / PROTÉGÉ C <input type="checkbox"/>
CONFIDENTIAL / CONFIDENTIEL <input type="checkbox"/>	NATO SECRET / NATO SECRET <input type="checkbox"/>	CONFIDENTIAL / CONFIDENTIEL <input type="checkbox"/>
SECRET / SECRET <input type="checkbox"/>	COSMIC TOP SECRET / COSMIC TRÈS SECRET <input type="checkbox"/>	SECRET / SECRET <input type="checkbox"/>
TOP SECRET / TRÈS SECRET <input type="checkbox"/>		TOP SECRET / TRÈS SECRET <input type="checkbox"/>
TOP SECRET (SIGINT) / TRÈS SECRET (SIGINT) <input type="checkbox"/>		TOP SECRET (SIGINT) / TRÈS SECRET (SIGINT) <input type="checkbox"/>



Contract Number / Numéro du contrat
Security Classification / Classification de sécurité

PART A (continued) / PARTIE A (suite)

8. Will the supplier require access to PROTECTED and/or CLASSIFIED COMSEC information or assets?
 Le fournisseur aura-t-il accès à des renseignements ou à des biens COMSEC désignés PROTÉGÉS et/ou CLASSIFIÉS? No / Non Yes / Oui
 If Yes, indicate the level of sensitivity:
 Dans l'affirmative, indiquer le niveau de sensibilité :

9. Will the supplier require access to extremely sensitive INFOSEC information or assets?
 Le fournisseur aura-t-il accès à des renseignements ou à des biens INFOSEC de nature extrêmement délicate? No / Non Yes / Oui

Short Title(s) of material / Titre(s) abrégé(s) du matériel :
 Document Number / Numéro du document :

PART B - PERSONNEL (SUPPLIER) / PARTIE B - PERSONNEL (FOURNISSEUR)

10. a) Personnel security screening level required / Niveau de contrôle de la sécurité du personnel requis

<input checked="" type="checkbox"/> RELIABILITY STATUS COTE DE FIABILITÉ	<input type="checkbox"/> CONFIDENTIAL CONFIDENTIEL	<input type="checkbox"/> SECRET SECRET	<input type="checkbox"/> TOP SECRET TRÈS SECRET
<input type="checkbox"/> TOP SECRET - SIGINT TRÈS SECRET - SIGINT	<input type="checkbox"/> NATO CONFIDENTIAL NATO CONFIDENTIEL	<input type="checkbox"/> NATO SECRET NATO SECRET	<input type="checkbox"/> COSMIC TOP SECRET COSMIC TRÈS SECRET
<input type="checkbox"/> SITE ACCESS ACCÈS AUX EMPLACEMENTS			

Special comments:
 Commentaires spéciaux : _____

NOTE: If multiple levels of screening are identified, a Security Classification Guide must be provided.
 REMARQUE : Si plusieurs niveaux de contrôle de sécurité sont requis, un guide de classification de la sécurité doit être fourni.

10. b) May unscreened personnel be used for portions of the work?
 Du personnel sans autorisation sécuritaire peut-il se voir confier des parties du travail? No / Non Yes / Oui
 If Yes, will unscreened personnel be escorted?
 Dans l'affirmative, le personnel en question sera-t-il escorté? No / Non Yes / Oui

PART C - SAFEGUARDS (SUPPLIER) / PARTIE C - MESURES DE PROTECTION (FOURNISSEUR)

INFORMATION / ASSETS / RENSEIGNEMENTS / BIENS

11. a) Will the supplier be required to receive and store PROTECTED and/or CLASSIFIED Information or assets on its site or premises?
 Le fournisseur sera-t-il tenu de recevoir et d'entreposer sur place des renseignements ou des biens PROTÉGÉS et/ou CLASSIFIÉS? No / Non Yes / Oui

11. b) Will the supplier be required to safeguard COMSEC information or assets?
 Le fournisseur sera-t-il tenu de protéger des renseignements ou des biens COMSEC? No / Non Yes / Oui

PRODUCTION

11. c) Will the production (manufacture, and/or repair and/or modification) of PROTECTED and/or CLASSIFIED material or equipment occur at the supplier's site or premises?
 Les installations du fournisseur serviront-elles à la production (fabrication et/ou réparation et/ou modification) de matériel PROTÉGÉ et/ou CLASSIFIÉ? No / Non Yes / Oui

INFORMATION TECHNOLOGY (IT) MEDIA / SUPPORT RELATIF À LA TECHNOLOGIE DE L'INFORMATION (TI)

11. d) Will the supplier be required to use its IT systems to electronically process, produce or store PROTECTED and/or CLASSIFIED information or data?
 Le fournisseur sera-t-il tenu d'utiliser ses propres systèmes informatiques pour traiter, produire ou stocker électroniquement des renseignements ou des données PROTÉGÉS et/ou CLASSIFIÉS? No / Non Yes / Oui

11. e) Will there be an electronic link between the supplier's IT systems and the government department or agency?
 Disposera-t-on d'un lien électronique entre le système informatique du fournisseur et celui du ministère ou de l'agence gouvernementale? No / Non Yes / Oui



Contract Number / Numéro du contrat
Security Classification / Classification de sécurité

PART C - (continued) / PARTIE C - (suite)

For users completing the form **manually** use the summary chart below to indicate the category(ies) and level(s) of safeguarding required at the supplier's site(s) or premises.
 Les utilisateurs qui remplissent le formulaire **manuellement** doivent utiliser le tableau récapitulatif ci-dessous pour indiquer, pour chaque catégorie, les niveaux de sauvegarde requis aux installations du fournisseur.

For users completing the form **online** (via the internet), the summary chart is automatically populated by your responses to previous questions.
 Dans le cas des utilisateurs qui remplissent le formulaire **en ligne** (par Internet), les réponses aux questions précédentes sont automatiquement saisies dans le tableau récapitulatif.

SUMMARY CHART / TABLEAU RÉCAPITULATIF

Category / Catégorie	PROTECTED / PROTÉGÉ			CLASSIFIED / CLASSIFIÉ			NATO				COMSEC					
	A	B	C	CONFIDENTIAL / CONFIDENTIEL	SECRET	TOP SECRET / TRÈS SECRET	NATO RESTRICTED / NATO DIFFUSION RESTREINTE	NATO CONFIDENTIAL / NATO CONFIDENTIEL	NATO SECRET	COSMIC TOP SECRET / COSMIC TRÈS SECRET	PROTECTED / PROTÉGÉ			CONFIDENTIAL / CONFIDENTIEL	SECRET	TOP SECRET / TRÈS SECRET
											A	B	C			
Information / Assets / Renseignements / Biens / Production	<input type="checkbox"/>	<input type="checkbox"/>	<input type="checkbox"/>	<input type="checkbox"/>	<input type="checkbox"/>	<input type="checkbox"/>	<input type="checkbox"/>	<input type="checkbox"/>	<input type="checkbox"/>	<input type="checkbox"/>	<input type="checkbox"/>	<input type="checkbox"/>	<input type="checkbox"/>	<input type="checkbox"/>	<input type="checkbox"/>	<input type="checkbox"/>
IT Media / Support TI	<input type="checkbox"/>	<input type="checkbox"/>	<input type="checkbox"/>	<input type="checkbox"/>	<input type="checkbox"/>	<input type="checkbox"/>	<input type="checkbox"/>	<input type="checkbox"/>	<input type="checkbox"/>	<input type="checkbox"/>	<input type="checkbox"/>	<input type="checkbox"/>	<input type="checkbox"/>	<input type="checkbox"/>	<input type="checkbox"/>	<input type="checkbox"/>
IT Link / Lien électronique	<input type="checkbox"/>	<input type="checkbox"/>	<input type="checkbox"/>	<input type="checkbox"/>	<input type="checkbox"/>	<input type="checkbox"/>	<input type="checkbox"/>	<input type="checkbox"/>	<input type="checkbox"/>	<input type="checkbox"/>	<input type="checkbox"/>	<input type="checkbox"/>	<input type="checkbox"/>	<input type="checkbox"/>	<input type="checkbox"/>	<input type="checkbox"/>

12. a) Is the description of the work contained within this SRCL PROTECTED and/or CLASSIFIED?
 La description du travail visé par la présente LVERS est-elle de nature PROTÉGÉE et/ou CLASSIFIÉE?
 No / Non Yes / Oui

If Yes, classify this form by annotating the top and bottom in the area entitled "Security Classification".
 Dans l'affirmative, classifiez le présent formulaire en indiquant le niveau de sécurité dans la case intitulée « Classification de sécurité » au haut et au bas du formulaire.

12. b) Will the documentation attached to this SRCL be PROTECTED and/or CLASSIFIED?
 La documentation associée à la présente LVERS sera-t-elle PROTÉGÉE et/ou CLASSIFIÉE?
 No / Non Yes / Oui

If Yes, classify this form by annotating the top and bottom in the area entitled "Security Classification" and indicate with attachments (e.g. SECRET with Attachments).
 Dans l'affirmative, classifiez le présent formulaire en indiquant le niveau de sécurité dans la case intitulée « Classification de sécurité » au haut et au bas du formulaire et indiquez qu'il y a des pièces jointes (p. ex. SECRET avec des pièces jointes).

Security Classification / Classification de sécurité
--



Contract Number / Numéro du contrat
Security Classification / Classification de sécurité

PART D - AUTHORIZATION / PARTIE D - AUTORISATION			
13. Organization Project Authority / Chargé de projet de l'organisme			
Name (print) - Nom (en lettres moulées) Christopher Day		Title - Titre Construction Project Manager	Signature <i>C. J. Day</i>
Telephone No. - N° de téléphone 613-993-3118	Facsimile No. - N° de télécopieur 613-957-9828	E-mail address - Adresse courriel Chris.Day@nrc-cnrc.gc.ca	Date Oct 20 2016
14. Organization Security Authority / Responsable de la sécurité de l'organisme			
Name (print) - Nom (en lettres moulées) Charlotte Carrier		Title - Titre Controlled Goods and Contracts Security Coordinator	Signature <i>[Signature]</i>
Telephone No. - N° de téléphone (613) 993-8956	Facsimile No. - N° de télécopieur (613) 990-0946	E-mail address - Adresse courriel Charlotte.Carrier@nrc-cnrc.gc.ca	Date 20 OCT 2016
15. Are there additional instructions (e.g. Security Guide, Security Classification Guide) attached? Des instructions supplémentaires (p. ex. Guide de sécurité, Guide de classification de la sécurité) sont-elles jointes?			<input checked="" type="checkbox"/> No / Non <input type="checkbox"/> Yes / Oui
16. Procurement Officer / Agent d'approvisionnement			
Name (print) - Nom (en lettres moulées) Alain Leroux		Title - Titre Senior Contracting Officer	Signature <i>AL</i>
Telephone No. - N° de téléphone 613-991-9980	Facsimile No. - N° de télécopieur 613-998-5701	E-mail address - Adresse courriel Alain.leroux@nrc-cnrc.gc.ca	Date Oct. 20, 2016
17. Contracting Security Authority / Autorité contractante en matière de sécurité			
Name (print) - Nom (en lettres moulées)		Title - Titre	Signature
Telephone No. - N° de téléphone	Facsimile No. - N° de télécopieur	E-mail address - Adresse courriel	Date

Security Classification / Classification de sécurité
--