

**FOR BID**



Parks  
Canada

Parcs  
Canada

## **Agence Parks Canada**

Machine Guarding Installation and  
Mechanical & Electrical Components Replacement  
at the Carillon Navigation Lock



L.H.N.C. du Canal-de-Carillon

O/ref N° Tetra Tech : 25608B

October 2016, Revision 00

**Canada**

**PARKS CANADA  
MACHINE GUARDING INSTALLATION AND  
MECHANICAL & ELECTRICAL COMPONENTS REPLACEMENT  
AT THE CARILLON NAVIGATION LOCK**

Prepared by : name/function	Approved by : name/discipline	Seal and date
Claude Rousseau, tech.	Benoît Tremblay, Eng. MECHANICAL	
Dominic Dubé, tech.	Jean-Daniel Coudé, Eng. ELECTRICAL	<p>REV.00</p> 

**END OF SECTION**

**PARKS CANADA  
MACHINE GUARDING INSTALLATION AND  
MECHANICAL & ELECTRICAL COMPONENTS REPLACEMENT  
AT THE CARILLON NAVIGATION LOCK**

**SECTION 00 01 10  
TABLE OF CONTENTS  
PAGE 1**

<b>Section Number</b>	<b>Section Title</b>	<b>Number of pages</b>
00 01 07	Seal and signature page	1
00 01 10	Table of contents	1
01 11 00	Work summary	7
01 33 00	Submittal procedures	4
01 35 29.06	Health and safety requirements	3
01 45 00	Quality control	2
01 52 00	Field installations	3
01 61 00	General product requirements	4
01 73 00	Work execution	2
01 74 11	Cleaning	2
01 74 21	Construction/demolition waste management and disposal	2
01 77 00	Work completion	2
01 91 13	General commissioning requirements	7
05 50 00	Metal work	5
14 20 04	Mechanical equipment	4
26 05 00	General electrical requirements	6
26 05 20	Wire and box connectors	2
26 05 21	Wire and cables (0-1000 V)	2
26 05 28	Grounding secondary	2
26 05 29	Support and suspensions for electrical installations	1
26 05 31	Cabinets, junction boxes, pull boxers and dividing boxes	2
26 28 23	Disconnect switches – fused and non fused	2
27 05 00	General telecom requirements	7
27 10 05	Telecommunication networks	3
Annex A	Reference drawings	
Annex B	Vertical gate and counterweight stabilization procedure	
Annex C	Mitigation and significance of residual effects	
Annex D	Technical specification	
Annex E	Bid form	

**END OF SECTION**

## **1 GENERAL**

### **1.01 WORK COVERED BY CONTRACT DOCUMENTS**

- .1 Work covered by this Contract comprises the upgrade of mechanical and electrical aspects of the Carillon navigation lock located on the Carillon canal national historic site in St-André-d'Argenteuil. Work includes, but is not limited to, the following:

### **1.02 MECHANICAL WORK**

- .1 Demolition and preparation work
  - .1 The Contractor shall supply labour, supervision, waste disposal, tools, equipment, machinery, scaffolding, materials, transportation, handling, boom truck rental, slings and all other accessories required to perform the demolition work as described on drawings and in technical specifications issued for construction.
  - .2 Demolition and preparation work by the Contractor includes, but is not limited to, the following activities:
    - a. **Inlet and outlet valves gates sector (left-right)**
      - .1 Removal of sheathing boards covering sector gate wells (right and left) (weight estimated at 5 MT each) and those covering inlet and outlet valves (weight estimated at 3 MT each) and their storage in a safe location; see project engineer.
        1. Note: the contractor shall consider that it is a roadway so protection shall be installed to avoid that either a vehicle or a pedestrian fall into the wells when their covers are removed during the works (winter roadway condition)
      - .2 Building of temporary shelters for the duration of the work over sector gate wells (right and left), and over the inlet and outlet valves and ensure temporary heating system to avoid the water of the wells to freeze.
      - .3 Cleaning of area for replacement work.
      - .4 Cleaning of open gears to remove any trace of grease on sector gates (right and left), inlet and outlet valves.
      - .5 Dismantling (during a shutdown) of the TRABON mechanical lubrication systems on inlet and outlet valves.
    - b. **Vertical Gate**
      - .6 Important note to perform the dismantling work for the vertical gate: to guarantee weight relief on the mechanical and brake, the contractor shall ensure that the counterweight is secured in its embedment. The Parks Canada Team will perform the “doggage” of the vertical gate but won't do it on the counterweight.
      7. The bidder shall provide a special articulated lift to perform work from the deck, steel plaques, hydraulic cylinders, etc. See procedure on the annex B explaining the required steps that has to be done by the bidder.
      8. Dismantle the existing motor, gear box and motor brake on the vertical gate.
      9. Dismantle primary sprocket between the first gear and the gear box. Keep for ulterior re-assemble.
      10. Dismantle motor brake rack.
      11. Perform the opening of the new conducts for the new motor brake (location following the final selection of the gearbox by the contractor).



- .2 Work to be performed
  - .1 The Contractor shall supply labour, supervision, tools, equipment, machinery, scaffolding, materials, transportation, handling, boom truck rental, slings and all other accessories required for the execution of the work as described on drawings and in the technical specification issued for construction.
  - .2 All dimensions indicated on drawings and in the technical specification are for information purposes only. It is the Contractor's responsibility to confirm them during the construction period (at no extra cost). The Contractor shall supply shop drawings for approval, as well as « As-built » drawings to client following work acceptance.
  - .3 The Contractor shall supply all materials and perform all work related to transportation and installation. Note that materials shall be transported to the jobsite by truck. The Contractor is responsible for the transportation, reception and unloading of materials on site.
  - .4 After the installation work, the contractor shall, when required, provide an alignment report on the components (gear, gearbox, motor).
  - .5 Work to be performed by the Contractor consist of:
    - a) **Inlet and outlet valves gate sector (left and right)**
      - i) **Machine Guarding**
        1. Fabricate and install fall protection ensuring minimum clearance required between left and right sector gates' articulated boom. Attach to the existing structure as indicated on the drawings. Add strips to limit the access to the openings. The objective is to prevent birds and snow to enter during winter (M05).
        2. Design, fabricate and install a safety barrier for coupling between left and right sector gates' motors and gear boxes (M01).
        - .3 Fabricate and install of safety barriers for space between gearbox and open gears for the left and right sector gates' open gears (M03).
        - .4 Fabricate a safety barrier for opening on gears (M04).
        - .5 Fabricate and install a safety barriers on speed sensors installed above left and right sector gates' gear boxes (M02).
        - .6 Fabricate and install access limiting barriers in the well of inlet and outlet valves' mechanisms, on the gate side. The objective is to prevent the access when the gears are powered (M06)
        7. Fabricate and install safety barriers for left and right sector gates' open gears, ensuring minimum required clearance and protect against birds and contaminants. Provide and install pans to collect the grease surplus (M03)
      - ii) Lubrication system
        8. Install automatic lubrication systems, P-203 type from LINCOLN-SKF provided by Parks Canada. The Contractor shall provide piping, supports and all other required accessories in accordance with manufacturer's recommendations.
        - .9 Provide flow sensor (LN800080 or approved equivalent) for lubrication pumps P-203 and P-653 de LINKCOLN-SKF or approved equivalent. The contractor shall provide all related equipment such as racks or any other accessories required following the manufacturer recommendations.
        - .10 Select, provide and install lubricate gears compatible with lubrication system provided and open gears.
        - .11 Provide and install lubrication systems and accessories based on the sketch (M18).

**b) Inlet and outlet valves**

**i. Machine Guarding**

- .12 Fabricate and install of safety barriers on inlet and outlet valves' couplings on the motor room side between the wall and the new 7.5 HP motor. 1
- .13 Design, fabricate and install safety barrier for limited access to the well of inlet and outlet mechanical, valve side. Panels shall be removable with a tool. Two (2) panels will be equipped with hinges and locks. Plate mentioning the limited access in the sector shall be installed, as represented on the drawings (M08).
- .14 Design, provide, fabricate and install two (2) attachment points for harness in the inlet and outlet sector gate wells with all accessories to hook a harness with a 18 kN capacity. Following the installation, perform a VTR inspection and provide a report to the site supervisor on the weld angle conformities.
- .15 Close openings from the outside with grilles to avoid bird presence in the inlet and outlet sector gates (see drawing M09)
- .16 Provide automatic lubrication systems type P-203 AV 8L (grease, low level) and P-653 (8 litre tank, 120 VLT with IPS for valve) LINCOLN-SFK or equivalent approved the LINCOLN-SFK distributors. The contractor shall provide all related equipment such as racks or any other accessories required following the manufacturer recommendations.
- .17 Provide flow sensor (LN800080 or approved equivalent) for lubrication pumps P-203 and P-653 de LINKCOLN-SKF or approved equivalent. The contractor shall provide all related equipment such as racks or any other accessories required following the manufacturer recommendations.
- .18 Select, provide and install lubricate gears compatible with lubrication system provided and open gears.
- .19 Provide and install lubrication systems and accessories based on the sketch (M19).

**c) Vertical Gate**

**.i) Machine guarding**

- .20 Design, fabricate and install safety barrier for pulleys, opened gears and closing of the openings up the stairs to eliminate the bird intrusion source (aluminum rail at the top of the stairs). A section of about 20 inches to close with aluminum grille. The contractor shall also ensure the protection of all other related openings with grilles.
- .21 Design, fabricate and install a cable counterweight mechanism for the safety barrier of the primary gear system.
- .22 Design, fabricate and install safety barrier for the secondary opened gear system of the vertical door (M11).
- .23 Design, fabricate and install counterweight mechanisms (2) and cables for the safety barrier handling of the secondary open gear train of the vertical gate. M11
- .24 Fabricate and install a safety barrier for the shaft between the recuperated pinion from the primary train gear and the new gearbox. M12
- .25 Fabricate and install safety barriers for drum of the counterweight system cables. M13
- .26 Fabricate and install safety barriers for the cables on the left and right side of the lifting mechanism of the vertical gate and its counterweight and limit the access to the friction brake from below (M14 and M15).
- .27 Fabricate and install a safety barrier limiting the access to the friction brake from both sides.

**ii. Supply and installation of new equipment**

- .28 Design, fabricate and install racks, shaft, bearing for pinion and coupling (1) for primary gear train and assemble with the new gearbox of the vertical gate.
- .29 Design, fabricate and install racks, shaft and bearing for lubricating pinion of the secondary gear train.
- .30 Design, fabricate and install racks, shaft and bearing for lubricating gear of the secondary gear train.
- 31. Design fabricate and install new tacks for motor brake install on the gearbox primary axis.
- 32. Dismantle the existing motor 40hp of the vertical gate and hand it over to the APC.
- 33. Handle and install the new motor of the vertical gate; the motor is providing by APC and store at the lock.
- 34. Fabricate and install exhaust duct between fan brake and vertical gate floor. Provide protection grilles at the entrance and the exit of the fan brake.
- .35 Provide and install gearbox between engine and primary train of the vertical door.
- .36 Design, fabricate and install new gearbox base.
- .37 Fabricate and install three (3) new pans for grease collection for the vertical door gearbox (M52)

**iii. New lubrication system**

- .38 Provide automatic lubrication systems P-653 (8 liter tank, 120 VLT with IPT for valve) LINCOLN-SFK The contractor shall provide all related equipment such as operation pipe, racks or any other accessories required following the manufacturer recommendations.
- .39 Provide flow sensor (LN800080 or approved equivalent) for lubrication pump P-653 LINKCOLN-SKF or approved equivalent. The contractor shall provide all related equipment such as racks or any other accessories required following the manufacturer recommendations.
- .40 Select, provide and install lubrication gears compatible with open gear lubrication systems.
- .41 Install lubrication system and accessories base on sketches M20.

**1.03 ELECTRICAL WORK**

- .1 The Contractor shall supply labour, supervision, tools, equipment, machinery, scaffolding, materials, transportation, handling, devices and equipment required to work in confined spaces, as well as all other accessories required for the execution of the work as described on drawings and in the technical specification issued for construction.
  - .1 All dimensions indicated on drawings and in the technical specification are for information purposes only. It is the Contractor's responsibility to confirm them during the construction period (at no extra cost).
  - .2 The Contractor shall supply technical data and shop drawings for approval, as well as « As-built » drawings to client following work acceptance.
  - .3 The Contractor shall supply all materials and perform all work related to transportation and installation. Note that materials shall be transported to the jobsite by truck. The Contractor is responsible for the transportation, reception and unloading of materials on site.

- .4 Work related to the vertical gate includes, but is not limited to, the following:
  - .1 The Contractor shall disconnect cables supplying the motor, brake and heating.
  - .2 The Contractor shall dismantle the motor conduit section at the first pull box.
  - .3 The contractor shall provide install and connect new local switch interrupters to the new motor. The cables are 3C#1/0 Cu teck 90 for motor powering, 4C#10 Cu teck 90 for the brakes and 3#10 Cu teck 90 for the heating.
  - .4 The contractor shall dismantle the existing devicenet encodor.
  - .5 The contractor shall provide, install ad connect a devincenet encoder brand Allan-Bradley, mode; 842-D60131331BDA to replace the existing encoder. Ensure devicenet cable with connector to replace the existing cable if required. Provide and install mounting rack and gear for the new encoder (see mechanical plan for the physical layout and localization). The rack shall be submitted to the Canada Parks representative for approval.
- .5 Work related to the installation for a permanent connecting point for the generator includes, but is not limited to, the following;
  - .1 The contractor shall provide, install, identify and connect a disconnecting switch 200A Nema 4X complete with fuses, as specified on the drawings.
  - .2 The contractor shall provide, install, identify and connect a distribution box NEMA 4x with connector “Camlock” as specified in the drawings.
  - .3 The contractor shall dismantle the existing distribution panel board 600V. Ensure to dismantle cables to use them for the connection the new panel.
  - .4 The contractor shall provide, install, identify and connect a new distribution panel board 600 V 250A, 25kA, 3 phases and 4 wires with the same specification than the existing one (model Cutler-Hammer). The panel shall have 25% of availability remaining for ulterior needs. Add a breaker 200A for connection of the generator.
  - .5 The contractor shall provide, install, identify and connect a “kirk Key” system between the main breaker of the MCC and the breaker 200A of the CDP for generator CDP. The system shall imperatively prevent that the normal power and the generator power work in the same time. The system shall be submitted to the Parks Canada representative for approval.
  - .6 The contractor shall drill two (2) openings in the concrete to allow the passage of the local disconnecting switch cable of the generator till the CDP panel of the electric room.
  - .7 The Contractor shall provide, install, identify and connect the cables and connectors, as specified on the drawing.
- .6 Work related to the lubrication system includes, but is not limited to, the following :
  - .1 The Contractor shall supply, install, identify and connect five (5) control panels for the lubrication system, as specified on drawings.
  - .2 The Contractor shall supply, install, identify and connect four (4) local stations near each lubrication pump of the inlet and outlet valves wells, as specified on the drawing.
  - .3 The Contractor shall install and connect ten (10) lubrication systems supplied by the mechanical division, as specified on drawings.
  - .4 The Contractor shall install and connect ten (10) lubricant flow sensor systems supplied by the mechanical division, as specified on drawings.
  - .5 The contractor shall connect, merge and identify the existing optic fiber network of the lubrication system, as specified on drawings.

- .6 The contractor shall provide, install, identify and connect cables and connector, as specified on drawings.
- .7 The contractor shall provide, install and connect five (5) circuit breaker 20A in the electric panel PE-1 to power each lubricant control panel, as specified on drawings.
- .8 The contractor shall provide, install and connect a fiber optic patch panel inside the existing rack in the electric room, as specified on drawings.
- .9 The contractor shall supply, install, identify and connect a Ethernet Optic fiber switch inside the existing rack in the electric room, as specified on drawings.
- .10 The contractor shall supply, install and connect all network connection cables required to the system good functioning, as specified on drawings.

.7 The Contractor shall carry out the commissioning of the equipment and ensure its proper operation.

#### **1.04 CONTRACT METHOD**

- .1 Employ qualified suppliers and subcontractors for:
  - .1 Work described in Section 14 20 04 related to lubrication mechanization for work regarding installation, preoperational checks and commissioning, including the piping section.

#### **1.05 WORK SEQUENCE**

- .1 Coordinate Progress Schedule in order to complete the Work before the start of the navigation season (before February 28, 2017).
- .2 Maintain access to bridge located upstream from the navigation lock to Hydro-Quebec staff at all times during the Work period.
- .3 Maintain access to navigation lock for fire protection purposes; also, fire-fighting facilities shall be provided.
- .4 Plan for the equipment lock-out/tag-out procedure and safe working conditions at all times.
- .5 Communicate with Parks Canada Representative before the beginning of the Work to schedule a visit for required surveys.

#### **1.06 CONTRACTOR'S USE OF PREMISES**

- .1 Limited use of premises for Work, for storage and for access to allow:
  - .1 Safe working conditions.
  - .2 Access to the bridge located upstream from the navigation lock to Hydro-Quebec staff.
- .1 Coordinate use of premises as indicated by Parks Canada Representative.
- .2 Prevent damage to existing structures.
- .3 Once Work is completed, existing structure shall be in a condition equivalent or superior to initial condition at the beginning of Work.

**1.07 DOCUMENTS REQUIRED**

- .1 Maintain at job site, one copy of each of the following documents:
  - .1 Contract Drawings.
  - .2 Specifications.
  - .3 Addenda. Of the new equipment
  - .4 Technical document
  - .5 Reviewed Shop Drawings.
  - .6 List of Outstanding Shop Drawings.
  - .7 Change Orders.
  - .8 Other Modifications to Contract.
  - .9 Field Test Reports.
  - .10 Copy of Approved Work Schedule.
  - .11 Health and Safety Plan and Other Safety Related Documents.
  - .12 Other documents as specified.

**2 PRODUCTS**

**2.01 NOT USED**

- .1 Not used.

**3 EXECUTION**

**3.01 NOT USED**

- .1 Not used.

**END OF SECTION**

## **1 GENERAL**

### **1.01 ADMINISTRATIVE PROCEDURES**

- .1 Submit to Parks Canada Representative submittals listed for review. Submit promptly and in orderly sequence to not cause delay in Work. Failure to submit in ample time is not considered sufficient reason for extension of Contract Time and no claim for extension by reason of such default will be allowed.
- .2 Do not proceed with Work affected by submittal until review is complete.
- .3 Present shop drawings, product data, samples and mock-ups in SI Metric units.
- .4 Where items or information is not produced in SI Metric units converted values are acceptable.
- .5 Review submittals prior to submission to Parks Canada Representative. This review represents that necessary requirements have been determined and verified, or will be, and that each submittal has been checked and coordinated with requirements of Work and Contract Documents. Submittals not stamped, signed, dated and identified as to specific project will be returned without being examined and considered rejected.
- .6 Notify Parks Canada Representative, in writing at time of submission, identifying deviations from requirements of Contract Documents stating reasons for deviations.
- .7 Verify field measurements and affected adjacent Work are coordinated.
- .8 Contractor's responsibility for errors and omissions in submission is not relieved by Parks Canada Representative's review of submittals.
- .9 Contractor's responsibility for deviations in submission from requirements of Contract Documents is not relieved by Parks Canada Representative's review.
- .10 Keep one reviewed copy of each submission on site.

### **1.02 SHOP DRAWINGS AND PRODUCT DATA**

- .1 The term "shop drawings" means drawings, diagrams, illustrations, schedules, performance charts, brochures and other data which are to be provided by Contractor to illustrate details of a portion of Work. Technical sheet shall also be provided.
- .2 Submit drawings stamped and signed by professional engineer registered or licensed in the Province of Quebec.
- .3 Indicate materials, methods of construction and attachment or anchorage, erection diagrams, connections, explanatory notes and other information necessary for completion of Work. When there are items or equipment attached or connected to other items or equipment, indicate that such items have been coordinated, regardless of Section under which adjacent items will be supplied and installed. Indicate cross references on design drawings and specifications.
- .4 Allow five (5) days for the Parks Canada Representative to review each bid.

- .5 Adjustments made on shop drawings by Parks Canada Representative are not intended to change Contract Price. If adjustments affect value of Work, state such in writing to Parks Canada Representative prior to proceeding with Work.
- .6 Make changes in shop drawings as Parks Canada Representative may require, consistent with Contract Documents. When resubmitting, notify Parks Canada Representative in writing of revisions other than those requested.
- .7 Submissions include:
  - .1 Date and revision dates.
  - .2 Project title and number.
  - .3 Name and address of:
    - .1 Subcontractor.
    - .2 Supplier.
    - .3 Manufacturer.
  - .4 Contractor's stamp, signed by Contractor's authorized representative certifying approval of submissions, verification of field measurements and compliance with Contract Documents.
  - .5 Details of appropriate portions of Work as applicable:
    - .1 Fabrication detail and material.
    - .2 New equipment technical sheet.
    - .3 Layout, showing dimensions, including identified field dimensions, and clearances.
    - .4 Setting or erection details.
    - .5 Capacities.
    - .6 Performance characteristics.
    - .7 Standards.
    - .8 Wiring diagrams.
    - .9 Single line and schematic diagrams.
- .8 After Parks Canada Representative's review, distribute copies.
- .9 Submit electronic copy of shop drawings for each requirement requested in specification Sections and as Parks Canada Representative may reasonably request.
- .10 Submit electronic copies of product data sheets or brochures for requirements requested in specification Sections and as requested by Parks Canada Representative where shop drawings will not be prepared due to standardized manufacture of product.
- .11 Submit electronic copies of test reports for requirements requested in specification Sections and as requested by Parks Canada Representative.
- .12 Submit electronic copies of certificates for requirements requested in specification Sections and as requested by Parks Canada Representative.
  - .1 Statements printed on manufacturer's letterhead and signed by responsible officials of manufacturer of product, system or material attesting that product, system or material meets specification requirements.
  - .2 Certificates must be dated after award of project contract complete with project name.



- .13 Submit electronic copies of manufacturer's instructions for requirements requested in specification Sections and as requested by Parks Canada Representative.
  - .1 Pre-printed material describing installation of product, system or material, including special notices and Material Safety Data Sheets concerning impedances, hazards and safety precautions.
- .14 Documentation of the testing and verification actions taken by manufacturer's representative to confirm compliance with manufacturer's standards or instructions.
- .15 Submit electronic copies of Manufacturer's Field Reports for requirements requested in specification Sections and as requested by Parks Canada Representative.
- .16 Delete information not applicable to project.
- .17 Supplement standard information to provide details applicable to project.
- .18 If upon review by Parks Canada Representative, no errors or omissions are discovered or if only minor corrections are made, copies will be returned and fabrication and installation of Work may proceed. If shop drawings are rejected, noted copy will be returned and resubmission of corrected shop drawings, through same procedure indicated above, must be performed before fabrication and installation of Work may proceed.
- .19 The review of shop drawings by the Parks Canada Representative is for sole purpose of ascertaining conformance with general concept.
  - .1 This review shall not mean that Parks Canada approves detail design inherent in shop drawings; this responsibility shall remain with the Contractor. Also, this review shall not relieve Contractor of responsibility for errors or omissions in shop drawings or of responsibility for meeting requirements of construction and Contract Documents.
  - .2 Without restricting generality of foregoing, Contractor is responsible for dimensions to be confirmed and correlated at job site, for information that pertains solely to fabrication processes or to techniques of construction and installation and for coordination of Work of sub-trades.

### **1.03 PHOTOGRAPHIC DOCUMENTATION**

- .1 Submit electronic copy of color digital photography in jpg format, standard resolution monthly with progress statement and as directed by Parks Canada Representative.
- .2 Project identification: name and number of project and date of exposure indicated.
- .3 Frequency of photographic documentation: as directed by Parks Canada Representative.

### **1.04 CERTIFICATES AND TRANSCRIPTS**

- .1 Submit transcription of insurance immediately following Contract award.

**PARKS CANADA  
MACHINE GUARDING INSTALLATION AND  
MECHANICAL & ELECTRICAL COMPONENTS REPLACEMENT  
AT THE CARILLON NAVIGATION LOCK**

**SECTION 01 33 00  
SUBMITTAL PROCEDURES  
PAGE 4**

**2 PRODUCTS**

**2.01 NOT USED**

.1 Not Used.

**3 EXECUTION**

**3.01 NOT USED**

.1 Not Used.

**END OF SECTION**

## **1 GENERAL**

### **1.01 REFERENCES**

- .1 Canada Labor Code, Part 2, Canada Occupational Safety and Health Regulations
- .2 Health Canada/Workplace Hazardous Materials Information System (WHMIS)
  - .1 Material Safety Data Sheets (MSDS).
- .3 Province of Quebec
  - .1 An Act Respecting Occupational Health and Safety, R.S.Q. 1997 (updated July 26, 2005)
- .4 Commission de la Santé et Sécurité au Travail, Machine Guarding, Prevention of mechanical hazards
- .5 Canadian Standard Association standard CSA Z432-04 on the safeguarding of machinery
- .6 Canadian Standard Association standard CSA Z259-15-12 on anchorage connectors

### **1.02 DOCUMENTS TO BE SUBMITTED FOR ACTION AND INFORMATION**

- .1 Submit documents in accordance with Section 01 33 00 - Submittal Procedures.
- .2 Submit site-specific Health and Safety Plan: Within 7 days after date of Notice to Proceed and prior to commencement of Work. Health and Safety Plan must include:
  - .1 Results of site specific safety hazard assessment.
  - .2 Results of safety and health risk or hazard analysis for site tasks and operation found in work plan.
  - .3 Plan to reduce and control safety hazards specific to the jobsite.
- .3 Submit copies of Contractor's authorized representative's work site health and safety inspection reports to Parks Canada Representative every week.
- .4 Submit copies of reports or directions issued by Federal and Provincial health and safety inspectors.
- .5 Submit copies of incident and accident reports.
- .6 Parks Canada Representative will review Contractor's site-specific Health and Safety Plan and provide comments to Contractor within 5 days after receipt of plan. Revise plan as appropriate and resubmit plan to Parks Canada Representative within 5 days after receipt of comments from Parks Canada Representative.
- .7 Parks Canada Representative's review of Contractor's final Health and Safety plan should not be construed as approval and does not reduce the Contractor's overall responsibility for construction Health and Safety.
- .8 Medical Surveillance: where prescribed by legislation, regulation or safety program, submit certification of medical surveillance for site personnel prior to commencement of Work, and submit additional certifications for any new site personnel to Parks Canada Representative.

- .9 On-site Contingency and Emergency Response Plan: address standard operating procedures to be implemented during emergency situations.
  - .1 Confined space procedure.
  - .2 Work at height procedure.
  - .3 Hot work procedure.
  - .4 Lock-out/tag-out procedure (“0 Energy”).

### **1.03 SAFETY ASSESSMENT**

- .1 Perform site specific safety hazard assessment related to project.

### **1.04 MEETINGS**

- .1 Schedule and administer Health and Safety meeting with Parks Canada Representative prior to commencement of Work.

### **1.05 GENERAL REQUIREMENTS**

- .1 Develop written site-specific Health and Safety Plan based on hazard assessment prior to beginning site Work and continue to implement, maintain, and enforce plan until final demobilization from site. Health and Safety Plan must address project specifications.
- .2 Parks Canada Representative may respond in writing, where deficiencies or concerns are noted and may request re-submission with correction of deficiencies or concerns.

### **1.06 RESPONSIBILITY**

- .1 Be responsible for health and safety of persons on site, safety of property on site and for protection of persons adjacent to site and environment to extent that they may be affected by conduct of Work. Provide personal protective equipment and other equipment required to ensure the safety of employees.
- .2 Comply with and enforce compliance by employees with safety requirements of Contract Documents, applicable federal, provincial, and local statutes, regulations, and ordinances, and with site-specific Health and Safety Plan.

### **1.07 COMPLIANCE REQUIREMENTS**

- .1 Comply with Occupational Health and Safety Act, Industrial and Commercial Establishments Regulation, R.R.Q.
- .2 Comply with Canada Labour Code, Canada Occupational Safety and Health Regulations.

**1.08 UNFORESEEN HAZARDS**

- .1 When unforeseen or peculiar safety-related factor, hazard, or condition occur during performance of Work, follow procedures in place for Employee's Right to Refuse Work in accordance with Acts and Regulations of Province of Quebec having jurisdiction and notify Parks Canada Representative verbally and in writing.

**1.09 POSTING OF DOCUMENTS**

- .1 Ensure applicable items, articles, notices and orders are posted in conspicuous location on site in accordance with Acts and Regulations of Quebec having jurisdiction, and in consultation with Parks Canada Representative.

**1.10 CORRECTION OF NON-COMPLIANCE**

- .1 Immediately address health and safety non-compliance issues identified by authority having jurisdiction or by Parks Canada Representative.
- .2 Provide Parks Canada Representative with written report of action taken to correct non-compliance of health and safety issues identified.
- .3 Parks Canada Representative may stop Work if non-compliance of health and safety regulations is not corrected.

**1.11 WORK STOPPAGE**

- .1 Give precedence to safety and health of public and site personnel and protection of environment over cost and schedule considerations for Work.

**2 PRODUCTS**

**2.01 NOT USED**

- .1 Not used.

**3 EXECUTION**

**3.01 NOT USED**

- .1 Not used.

**END OF SECTION**

## **1 GENERAL**

### **1.01 INSPECTION**

- .1 Allow Parks Canada Representative access to Work. If part of Work is in preparation at locations other than Place of Work, allow access to such Work whenever it is in progress.
- .2 If Contractor covers or permits to be covered Work that has been designated for special tests, inspections or approvals before such is made, uncover such Work, have inspections or tests satisfactorily completed and make good such Work.
- .3 Parks Canada Representative will order part of Work to be examined if Work is suspected to be not in accordance with Contract Documents. If, upon examination such work is found not in accordance with Contract Documents, correct such Work and pay cost of examination and correction. If such Work is found to be in accordance with Contract Documents, Parks Canada Representative shall pay for the costs of examination and replacement.

### **1.02 PROCEDURES**

- .1 Notify appropriate agency Parks Canada Representative in advance of requirement for tests, in order that attendance arrangements can be made.
- .2 Submit samples and/or materials required for testing, as specifically requested in specifications. Submit with reasonable promptness and in orderly sequence to not cause delays in Work.

### **1.03 REJECTED WORK**

- .1 Remove defective Work, whether result of poor workmanship, use of defective products or damage and whether incorporated in Work or not, which has been rejected by Parks Canada Representative as failing to conform to Contract Documents. Replace or re-execute in accordance with Contract Documents.
- .2 If, in the opinion of the Parks Canada Representative, it is not expedient to correct defective Work or Work not performed in accordance with Contract Documents, Owner shall deduct from Contract Price difference in value between Work performed and that called for by Contract Documents, amount of which will be determined by Parks Canada Representative.

### **1.04 REPORTS**

- .1 Submit one copy of inspection and test reports to Parks Canada Representative.

### **1.05 EQUIPMENT AND SYSTEMS**

- .1 Submit adjustment and balancing reports for mechanical, electrical systems.

**PARKS CANADA  
MACHINE GUARDING INSTALLATION AND  
MECHANICAL & ELECTRICAL COMPONENTS REPLACEMENT  
AT THE CARILLON NAVIGATION LOCK**

**SECTION 01 45 00  
QUALITY CONTROL  
PAGE 2**

**2 PRODUCTS**

**2.01 NOT USED**

.1 Not Used.

**3 EXECUTION**

**3.01 NOT USED**

.1 Not Used.

**END OF SECTION**

## **1 GENERAL**

### **1.01 REFERENCES**

- .1 Canadian General Standards Board (CGSB)
  - .1 CGSB 1.59-97, Alkyd Exterior Gloss Enamel.
- .2 Canadian Standards Association (CSA International)
  - .1 CAN/CSA-S269.2-M1987 (R2003), Access Scaffolding for Construction Purposes.
  - .2 CAN/CSA-Z321-96 (R2006), Signs and Symbols for the Occupational Environment.

### **1.02 DOCUMENTS TO BE SUBMITTED FOR ACTION AND INFORMATION**

- .1 Submit documents in accordance with Section 01 33 00 - Submittal Procedures.

### **1.03 MATERIAL INSTALLATION AND REMOVAL**

- .1 Prepare site plan indicating proposed location and dimensions of area to be fenced and used by Contractor, number of trailers to be used, access roads to fenced area and details of fence installation.
- .2 Plan for the power supply of trailer(s) to be completely independent (i.e. generator).
- .3 Indicate use of additional or other transit areas.
- .4 Provide construction facilities in order to execute work expeditiously.
- .5 Remove material from site when no longer used.

### **1.04 SCAFFOLDING**

- .1 Scaffolding in accordance with CAN/CSA-S269.2.
- .2 Provide and maintain scaffolding, platforms and temporary stairs.

### **1.05 HOISTING EQUIPMENT**

- .1 Provide, operate and maintain hoists and cranes required for the moving of workers, materials and equipment.
- .2 Hoists cranes to be operated by qualified operators.
- .3 Submit lifting plans for approval by the Parks Canada Representative; however, approval by the Ministry does not relieve the Contractor of his responsibility.

### **1.06 SITE STORAGE/LOADING**

- .1 Restrict work and operations of employees within Contract Documents boundaries. Do not unreasonably encumber premises with products.



- .2 Do not load or permit to load any part of Work with weight or force that will endanger Work.

#### **1.07 SECURITY**

- .1 Provide and pay for responsible security personnel to guard site and contents of site after working hours and during holidays.

#### **1.08 OFFICES**

- .1 Provide office heated to 22 degrees C, lighted 750 lx and ventilated, of sufficient size to accommodate site meetings and furnished with a table large enough to review drawings.
- .2 Provide marked and fully stocked first-aid case and fire extinguisher in a readily available location.

#### **1.09 EQUIPMENT, TOOL AND MATERIALS STORAGE**

- .1 Provide and maintain, in clean and orderly condition, lockable weatherproof sheds for storage of tools, equipment and materials.
- .2 Locate materials not required to be stored in weatherproof sheds on site in manner to cause least interference with work activities.

#### **1.10 SANITARY FACILITIES**

- .1 Provide sanitary facilities for work force in accordance with governing regulations and ordinances.
- .2 Post notices and take precautions as required by local health authorities. Keep area and premises in sanitary condition.

#### **1.11 CONSTRUCTION SIGNAGE**

- .1 Provide and erect project sign, within three weeks of signing Contract, in a location designated by Parks Canada Representative.
- .2 No other signs or advertisements, other than warning signs, are permitted on site.
- .3 Direct requests for approval to erect Consultant/Contractor signboard to Parks Canada Representative. The overall appearance of Consultant/Contractor's signboard must conform to project identification site sign. Wording in both official languages.
- .4 Signs and notices for safety and instruction in both official languages Graphic symbols to CAN/CSA-Z321.
- .5 Maintain approved signs and notices in good condition for the duration of project, and dispose of off site upon completion of project.

#### **1.12 TRAFFIC PROTECTION AND FLOW**

- .1 Provide access and temporary relocated roads as necessary to ensure traffic flow.

- .2 Protect pedestrian traffic and ensure traffic flow on deck during the construction period except as otherwise specifically directed by the Parks Canada Representative. Provide snow removal during period of Work to allow deck access. Maintenance of navigation lock access road be will be ensured by Parks Canada Agency. Note that is it forbidden to pour salt on deck, but the pouring of sand is acceptable.
- .3 Contractor's traffic on roads selected for hauling material to and from site to interfere as little as possible with traffic on temporary bridge upstream of lock.
- .4 Verify adequacy of existing roads and allowable load limit on these roads. Contractor is responsible for repair of damage to roads caused by construction operations.
- .5 Provide necessary lighting, signs, barricades, and distinctive markings for safe movement of pedestrian traffic.

### **1.13 CLEAN-UP**

- .1 Remove construction debris, waste materials, packaging material from work site daily.
- .2 Store materials resulting from demolition activities that are salvageable.
- .3 Stack stored new or salvaged material not in construction facilities.

## **2 PRODUCTS**

### **2.01 NOT USED**

- .1 Not Used.

## **3 EXECUTION**

### **3.01 TEMPORARY EROSION AND SEDIMENTATION CONTROL**

- .1 Not Used.

**END OF SECTION**

## **1 GENERAL**

### **1.01 REFERENCES**

- .1 Relevant standards may be referred to in each section of the technical specification.
- .2 Conform to these reference standards, in whole or in part, as specifically requested in specifications.
- .3 If there is question as to whether products or systems are compliant with applicable standards, Parks Canada Representative reserves right to have such products or systems tested to prove or disprove compliance.
- .4 Costs for such testing will be borne by Parks Canada in case of compliance with Contract Documents, or by Contractor in case of non-compliance.

### **1.02 QUALITY**

- .1 Products, materials, equipment and articles incorporated in Work shall be new, not damaged or defective, and of best quality for purpose intended. If requested, supply evidence as to type, source and quality of products provided.
- .2 Defective products, whenever identified prior to completion of Work, will be rejected, regardless of previous inspections. Inspection does not relieve responsibility, but is precaution against oversight or error. Remove and replace defective products at own expense and be responsible for delays and expenses caused by rejection.
- .3 Should disputes arise as to quality or fitness of products, decision rests strictly with Parks Canada Representative based upon requirements of Contract Documents.
- .4 Unless otherwise indicated in specifications, maintain uniformity of manufacture for any particular or like item throughout building.
- .5 Permanent labels, trademarks and nameplates on products are not acceptable in prominent locations, except where required for operating instructions, or when located in mechanical or electrical rooms.

**1.03 AVAILABILITY**

- .1 Immediately upon signing Contract, review product delivery requirements and anticipate foreseeable supply delays for items. If delays in supply of products are foreseeable, notify Parks Canada Representative of such, in order that substitutions or other remedial action may be authorized in ample time to prevent delay in performance of Work.
- .2 In event of failure to notify Parks Canada Representative at commencement of Work and should it subsequently appear that Work may be delayed for such reason, Parks Canada Representative reserves right to substitute more readily available products of similar character, at no increase in Contract Price or Contract Time.

**1.04 STORAGE, HANDLING AND PROTECTION**

- .1 Handle and store products in manner to prevent damage, adulteration, deterioration and soiling and in accordance with manufacturer's instructions when applicable.
- .2 Store packaged or bundled products in original and undamaged condition with manufacturer's seal and labels intact. Do not remove from packaging or bundling until required in Work.
- .3 Store products subject to damage from weather in weatherproof enclosures.
- .4 Keep sand, when used for grout or mortar materials, clean and dry. Store sand on wooden platforms and cover with waterproof tarpaulins during inclement weather.
- .5 Store and mix paints in heated and ventilated room. Remove oily rags and other combustible debris from site daily. Take every precaution necessary to prevent spontaneous combustion.
- .6 Remove and replace damaged products at own expense and to satisfaction of Parks Canada Representative.
- .7 Touch-up damaged factory finished surfaces to Parks Canada Representative's satisfaction. Use touch-up materials to match original. Do not paint over name plates.

**1.05 TRANSPORTATION**

- .1 Pay costs of transportation of products required in performance of Work.
- .2 Transportation cost of products supplied by Owner will be paid for by Parks Canada Representative. Unload, handle and store such products.

**1.06 MANUFACTURER'S INSTRUCTIONS**

- .1 Unless otherwise indicated in specifications, install or erect products in accordance with manufacturer's instructions. Do not rely on labels or enclosures provided with products. Obtain written instructions directly from manufacturers.
- .2 Notify Parks Canada Representative in writing, of conflicts between specifications and manufacturer's instructions, so that Parks Canada Representative will establish course of action.

- .3 Improper installation or erection of products, due to failure in complying with these requirements, authorizes Parks Canada Representative to require removal and re-installation at no increase in Contract Price or Contract Time.

#### **1.07 QUALITY OF WORK**

- .1 Ensure Quality of Work is of highest standard, executed by workers experienced and skilled in respective duties for which they are employed. Immediately notify Parks Canada Representative if required Work is such as to make it impractical to produce required results.
- .2 Do not employ anyone unskilled in their required duties. Parks Canada Representative reserves right to require dismissal from site, workers deemed incompetent or careless.
- .3 Decisions as to standard or fitness of Quality of Work in cases of dispute rest solely with Parks Canada Representative, whose decision is final.

#### **1.08 COORDINATION**

- .1 Ensure cooperation of workers in laying out Work. Maintain efficient and continuous supervision.

#### **1.09 REMEDIAL WORK**

- .1 Perform remedial work required to repair or replace parts or portions of Work identified as defective or unacceptable. Coordinate adjacent affected Work as required.
- .2 Perform remedial work by specialists familiar with materials affected. Perform in a manner to neither damage nor put at risk any portion of Work.

#### **1.10 LOCATION OF DEVICES**

- .1 Consider equipment's dimensions and location indicated as approximate. Contractor is responsible to make sure dimensions and location are adequate.
- .2 Inform Parks Canada Representative of conflicting installations. Install as directed by Parks Canada Representative.

#### **1.11 FASTENINGS**

- .1 Provide metal fastenings and accessories in same texture, colour and finish as adjacent materials, unless indicated otherwise.
- .2 Prevent electrolytic action between dissimilar metals and materials.
- .3 Use non-corrosive hot dip galvanized steel fasteners and anchors for securing exterior work, unless stainless steel or other material is specifically requested in affected specification Section.

**PARKS CANADA  
MACHINE GUARDING INSTALLATION AND  
MECHANICAL & ELECTRICAL  
COMPONENTS REPLACEMENT  
AT THE CARILLON NAVIGATION LOCK**

**SECTION 01 61 00  
GENERAL PRODUCT REQUIREMENTS  
PAGE 4**

**2 PRODUCTS**

**2.01 NOT USED**

.1 Not Used.

**3 EXECUTION**

**3.01 NOT USED**

.1 Not Used.

**END OF SECTION**

## **1 GENERAL**

### **1.01 DOCUMENTS TO BE SUBMITTED FOR ACTION AND INFORMATION**

- .1 Submit documents in accordance with Section 01 33 00 - Submittal Procedures.
- .2 Submit written request in advance of cutting or alteration which affects:
  - .1 Structural integrity of elements of project.
  - .2 Integrity of weather-exposed elements.
  - .3 Efficiency, maintenance, or safety of operational elements.
  - .4 Visual qualities of sight-exposed elements.
  - .5 Work of Owner or separate contractor.
- .3 Include in request:
  - .1 Identification of project.
  - .2 Location and description of affected Work.
  - .3 Statement on necessity for cutting or alteration.
  - .4 Description of proposed Work, and products to be used.
  - .5 Alternatives to cutting and patching.
  - .6 Effect on Work of Owner or separate contractor.
  - .7 Written permission of affected separate contractor.
  - .8 Date and time work will be executed.

### **1.02 MATERIALS**

- .1 According to section 05 50 00.

### **1.03 PREPARATION**

- .1 Inspect existing conditions, including elements subject to damage or movement during cutting and patching.
- .2 After uncovering, inspect conditions affecting performance of Work.
- .3 Provide supports to ensure structural integrity of surroundings; provide devices and methods to protect other portions of project from damage.
- .4 Provide protection from elements for areas which are to be exposed by uncovering work.
- .5 During the inlet and outlet valve works, ensure that no material, equipment or accessories fall into the well as this could stop the movement of the inlet and outlet valves in the bottom of the well.
- .6 Before starting the work on the sector gate equipment, take the necessary measures to perform the “doggage” by APC and secure the 190 tons counterweight.

**1.04 EXECUTION**

- .1 Execute cutting, fitting, and welding to complete Work.
- .2 Ask to the site supervisor the location to connect the grounding before performing welding work to avoid damaging components.
- .3 Fit several parts together, to integrate with other Work.
- .4 Remove and replace defective and non-conforming Work following Parks Canada Representative's approval.

**1.05 WASTE MANAGEMENT AND DISPOSAL**

- .1 Separate waste materials for recycling in accordance with Section 01 74 21 - Construction/Demolition Waste Management and Disposal.

**2 PRODUCTS**

**2.01 NOT USED**

- .1 Not Used.

**3 EXECUTION**

**3.01 NOT USED**

- .1 Not Used.

**END OF SECTION**



## **1 GENERAL**

### **1.01 JOBSITE CLEANLINESS**

- .1 Keep work area in tidy condition, free from accumulation of waste products and debris.
- .2 Dispose of waste materials and debris off site. Do not burn waste materials on site.
- .3 Clear snow and ice from deck, remove from site.
- .4 Make arrangements with and obtain permits from authorities having jurisdiction for disposal of waste and debris.
- .5 Provide on-site containers for the collection of waste materials and debris.
- .6 Provide and use marked separate bins for recycling. Refer to Section 01 74 21 - Construction/ Demolition Waste Management and Disposal.
- .7 Store volatile waste in covered metallic containers.
- .8 Provide adequate ventilation when using volatile or toxic substances.
- .9 Schedule cleaning operations so that resulting dust, debris and other contaminants will not fall on wet, newly painted surfaces.

### **1.02 FINAL CLEANING**

- .1 When Work is near completion, remove surplus products, tools, construction machinery and equipment not required for performance of remaining Work.
- .2 Remove waste products and debris and leave Work area clean.
- .3 Prior to final inspection, remove surplus products, tools, construction machinery and equipment.
- .4 Remove waste materials from site at regularly scheduled times. Do not burn waste materials on site.
- .5 Make arrangements with and obtain permits from authorities having jurisdiction for disposal of waste and debris.
- .6 Broom clean and wash exterior sidewalks, steps and surfaces; rake clean other ground surfaces.
- .7 Remove dirt and other elements marring the external surfaces.

### **1.03 WASTE MANAGEMENT AND DISPOSAL**

- .1 Separate waste materials for recycling in accordance with Section 01 74 21 - Construction/ Demolition Waste Management And Disposal.

**PARKS CANADA  
MACHINE GUARDING INSTALLATION AND  
MACHANICAL & ELECTRICAL COMPONENTS REPLACEMENT  
AT THE CARILLON NAVIGATION LOCK**

**SECTION 01 74 11  
CLEANING  
PAGE 2**

**2 PRODUCTS**

**2.01 NOT USED**

.1 Not Used.

**3 EXECUTION**

**3.01 NOT USED**

.1 Not Used.

**END OF SECTION**

## **1 GENERAL**

### **1.01 WASTE MANAGEMENT GOALS**

- .1 Before the beginning of the work, meet the ministry representative to review the APC plan and objectives regarding waste management.
- .2 Accomplish maximum control of solid construction waste.
- .3 Preserve environment and prevent pollution and environment damage.

### **1.02 DEFINITIONS**

- .1 Class III: non-hazardous waste - construction renovation and demolition waste.
- .2 Recyclable: ability of product or material to be recovered at end of its life cycle and re-manufactured into new product for reuse.
- .3 Recycle: process by which waste and recyclable materials are transformed or collected for purpose of being transferred into new products.
- .4 Recycling: process of sorting, cleansing, treating and reconstituting solid waste and other discarded materials for purpose of using in altered form. Recycling does not include burning, incinerating, or thermally destroying waste.
- .5 Recuperation: removing of the loadbearing or non-loadbearing construction component and material during the demolition or the dismantling of commercial, industrial or institutional structures to either reuse it or recycle them.
- .6 Separate Condition: refers to waste sorted into individual types.
- .7 Source Separation: acts of keeping different types of waste materials separate beginning from first time they became waste.

### **1.03 STORAGE, HANDLING AND PROTECTION**

- .1 Unless specified otherwise, materials for removal do not become Contractor's property.

### **1.04 DISPOSAL OF WASTES**

- .1 Do not bury rubbish or waste materials.
- .2 Do not dispose of waste into waterways, storm, or sanitary sewers.

### **1.05 USE OF SITE AND FACILITIES**

- .1 Execute work and leave free access to navigation lock's upstream bridge.
- .2 Provide temporary security measures approved by the Parks Canada Representative.

**1.06 SCHEDULING**

- .1 Coordinate Work with other activities at site to ensure timely and orderly progress of Work.

**2 PRODUCTS**

**2.01 NOT USED**

- .1 Not Used.

**3 EXECUTION**

**3.02 APPLICATION**

- .1 Handle waste materials not reused, salvaged, or recycled in accordance with appropriate regulations and codes.

**3.03 CLEANING**

- .1 Refer to section 01 74 11 - Cleaning.

## **1 GENERAL**

### **1.01 ADMINISTRATIVE REQUIREMENTS**

- .1 Acceptance of Work Procedures:
  - .1 Contractor's Inspection: Contractor: conduct inspection of Work, identify deficiencies and defects, and repair as required to conform to Contract Documents.
    - .1 Notify Parks Canada Representative in writing of satisfactory completion of Contractor's inspection and submit verification that corrections have been made.
    - .2 Request Parks Canada Representative's inspection.
  - .2 Parks Canada Representative's Inspection:
    - .1 Parks Canada Representative and Contractor to inspect Work and identify defects and deficiencies.
    - .2 Contractor to correct Work as directed.
  - .3 Completion Tasks: submit written certificates in English or French that tasks have been performed as follows:
    - .1 Work: completed and inspected for compliance with Contract Documents.
    - .2 Defects: corrected and deficiencies completed.
    - .3 Equipment and systems: tested, adjusted and balanced and fully operational.
    - .5 Operation of systems: demonstrated to Owner's personnel.
    - .6 Commissioning of mechanical systems: completed according to requirements in Section 01 91 13 – General Commissioning Requirements, and copies of final Commissioning Report submitted to the Parks Canada Representative.
    - .7 Work: complete and ready for final inspection.
  - .4 Final Inspection:
    - .1 When completion tasks are done, request final inspection of Work by Parks Canada Representative, and Contractor.
    - .2 When Work incomplete according to Parks Canada Representative, complete outstanding items and request re-inspection.

### **1.02 FINAL CLEANING**

- .1 Clean in accordance with Section 01 74 11 - Cleaning.
  - .1 Remove surplus materials, excess materials, rubbish, tools and equipment.
- .2 Waste Management: separate waste materials for recycling in accordance with Section 01 74 21 - Construction/Demolition Waste Management and Disposal.

## **2 PRODUCTS**

### **2.01 NOT USED**

- .1 Not Used.

**PARKS CANADA  
MACHINE GUARDING INSTALLATION AND  
MECHANICAL & ELECTRICAL COMPONENTS REPLACEMENT  
AT THE CARILLON NAVIGATION LOCK**

**SECTION 01 77 00  
WORK COMPLETION  
PAGE 2**

**3 EXECUTION**

**3.01 NOT USED**

.1 Not Used.

**END OF SECTION**

## **1 GENERAL**

### **1.01 SUMMARY**

- .1 Section Includes:
  - .1 General requirements relating to commissioning of project's components and systems, including those related to performance control (PC) of components, equipment, sub-systems, systems, and integrated systems.
- .2 Acronyms:
  - .1 Cx - Commissioning.
  - .2 O&M - Operation and Maintenance.
  - .3 PI - Product Information.
  - .4 PC - Performance Control.
  - .5 TAB - Testing, Adjusting and Balancing.

### **1.02 GENERAL**

- .1 Cx is a planned program of tests, procedures and checks carried out systematically on systems and integrated systems of the finished Project. Cx is performed after systems and integrated systems are completely installed, functional and Contractor's Performance Verification responsibilities have been completed and approved. Objectives:
  - .1 Verify installed equipment, systems and integrated systems operate in accordance with contract documents and design criteria and intent.
  - .2 Effectively train O&M staff.
- .2 Contractor assists in Cx process, operating equipment and systems, troubleshooting and making adjustments as required.
  - .1 Systems to be operated at full capacity under various modes to determine if they function correctly and consistently at peak efficiency. Systems to be interactively with each other as intended in accordance with Contract Documents and design criteria.
  - .2 During these checks, adjustments to be made to enhance performance to meet environmental or user requirements.
- .3 Design Criteria: as per client's requirements or determined by designer. To meet Project functional and operational requirements.

### **1.03 COMMISSIONING OVERVIEW**

- .1 Testing shall take place in the presence of the Parks Canada Representative, be certified by him/her, and reports shall be submitted to him/her.
- .2 Cx to be a line item of Contractor's cost breakdown.
- .3 Cx activities supplement field quality and testing procedures described in relevant technical sections.

- .4 Cx is conducted in concert with activities performed during stage of project delivery. Cx identifies issues in Planning and Design stages which are addressed during Construction and Cx stages to ensure the work is constructed and proven to operate satisfactorily under weather, environmental and occupancy conditions to meet functional and operational requirements. Cx activities includes transfer of critical knowledge to facility operational personnel.
- .5 Parks Canada Representative will issue Interim Acceptance Certificate when:
  - .1 Completed Cx documentation has been received, reviewed for suitability and approved by Parks Canada Representative.
  - .2 Equipment, components and systems have been commissioned.
  - .3 O&M training has been completed.

#### **1.04 NON-CONFORMANCE TO PERFORMANCE VERIFICATION REQUIREMENTS**

- .1 Should equipment, system components, and associated controls be incorrectly installed or malfunction during Cx, correct deficiencies, re-verify equipment and components within the unfunctional system, including related systems as deemed required by Parks Canada Representative, to ensure effective performance.
- .2 Costs for corrective work, additional tests, inspections, to determine acceptability and proper performance of such items to be borne by Contractor. Above costs to be in form of progress payment reductions or hold-back assessments.

#### **1.05 PRE-CX REVIEW**

- .1 Before Construction:
  - .1 Review contract documents, confirm by writing to Parks Canada Representative.
    - .1 Adequacy of provisions for Cx.
    - .2 Aspects of design and installation pertinent to success of Cx.
- .2 During Construction:
  - .1 Co-ordinate provision, location and installation of provisions for Cx.
- .3 Before start of Cx:
  - .1 Have completed Cx Plan up-to-date.
  - .2 Ensure installation of related components, equipment, sub-systems, systems is complete.
  - .3 Fully understand Cx requirements and procedures.
  - .4 Have Cx documentation shelf-ready.
  - .5 Understand completely design criteria and intent and special features.
  - .6 Submit complete start-up documentation to Parks Canada Representative.
  - .7 Have Cx schedules up-to-date.
  - .8 Ensure systems have been cleaned thoroughly.
  - .9 Complete TAB procedures on systems, submit TAB reports to Parks Canada Representative for review and approval.
  - .10 Ensure "As-Built" system schematics are available.
- .4 Inform Parks Canada Representative in writing of discrepancies and deficiencies on finished works.



**1.06 CONFLICTS**

- .1 Report conflicts between requirements of this section and other sections to Parks Canada Representative before start-up and obtain clarification.
- .2 Failure to report conflict and obtain clarification will result in application of most stringent requirement.

**1.07 DOCUMENTS TO BE SUBMITTED FOR ACTION AND INFORMATION**

- .1 Submittals: in accordance with Section 01 33 00 - Submittal Procedures.
  - .1 Submit no later than 4 weeks after award of Contract:
    - .1 Draft Cx documentation.
    - .2 Preliminary Cx schedule.
  - .2 Request in writing to Parks Canada Representative for changes to submittals and obtain written approval at least 4 weeks prior to start of Cx.
  - .3 Submit proposed Cx procedures to Parks Canada Representative where not specified and obtain written approval at least 4 weeks prior to start of Cx.
  - .4 Provide additional documentation relating to Cx process required by Parks Canada Representative.

**1.08 COMMISSIONING DOCUMENTATION**

- .1 Parks Canada Representative to review and approve Cx documentation.
- .2 Provide completed and approved Cx documentation to Parks Canada Representative.

**1.09 COMMISSIONING SCHEDULE**

- .1 Provide adequate time for Cx activities prescribed in technical sections and commissioning sections including:
  - .1 Approval of Cx reports.
  - .2 Verification of reported results.
  - .3 Repairs, retesting, re-commissioning, re-verification.
  - .4 Training.

**1.10 COMMISSIONING MEETINGS**

- .1 Purpose: to resolve issues, monitor progress, identify deficiencies, relating to Cx.
- .2 Continue Cx meetings on regular basis until commissioning deliverables have been addressed.
- .3 Thereafter Cx meetings to be held until project completion and as required during equipment start-up and functional testing period.
- .4 Meeting will be chaired by Parks Canada Representative, who will record and distribute minutes.
- .5 Ensure subcontractors and relevant manufacturer representatives are present at Cx meetings and as required.

### **1.11 STARTING AND TESTING**

- .1 Contractor assumes liabilities and costs for inspections. Including disassembly and re-assembly after approval, starting, testing and adjusting, including supply of testing equipment.

### **1.12 WITNESSING OF STARTING AND TESTING**

- .1 Provide a 10-day notice prior to commencement.
- .2 Parks Canada Representative to witness start-up and testing.
- .3 Contractor's Cx Agent to be present at tests performed and documented by sub-trades, suppliers and equipment manufacturers.

### **1.13 MANUFACTURER'S INVOLVEMENT**

- .1 Factory testing: Contractor to:
  - .1 Coordinate time and location of testing.
  - .2 Provide testing documentation for approval by Parks Canada Representative.
  - .3 Arrange for Parks Canada Representative to witness tests.
  - .4 Obtain written approval of test results and documentation from Parks Canada Representative before delivery to site.
- .2 Obtain manufacturers installation, start-up and operations instructions prior to start-up of components, equipment and systems and review with Parks Canada Representative
  - .1 Compare completed installation with manufacturer's published data, record discrepancies, and review with manufacturer.
  - .2 Modify procedures detrimental to equipment performance and review same with manufacturer before start-up.
- .3 Integrity of warranties:
  - .1 Use manufacturer's trained start-up personnel where specified elsewhere in other divisions or required to maintain integrity of warranty.
  - .2 Verify with manufacturer that testing as specified will not void warranties.

### **1.14 PROCEDURES**

- .1 Verify that equipment and systems are complete, clean, and operating in normal and safe manner prior to conducting start-up, testing and Cx.
- .2 Conduct start-up and testing in following distinct phases:
  - .1 Included in delivery and installation:
    - .1 Verification of conformity to specification, approved shop drawings and completion of PI report forms.
    - .2 Visual inspection of quality of installation.
  - .2 Start-up: follow accepted start-up procedures.
  - .3 Operational testing: document equipment performance.
  - .4 Performance control (PC): when required, perform new tests once deficiencies have been corrected.
  - .5 Near-completion performance control (PC) : to include fine-tuning.

- .3 Correct deficiencies and obtain approval from Parks Canada Representative after distinct phases have been completed and before commencing next phase.
- .4 Document require tests on approved PC forms.
- .5 Failure to follow accepted start-up procedures will result in re-evaluation of equipment by an independent testing agency selected by Parks Canada Representative. If results reveal that equipment start-up was not in accordance with requirements, and resulted in damage to equipment, implement the corrective actions approved by the Parks Canada representative.

#### **1.15 START-UP DOCUMENTATION**

- .1 Assemble start-up documentation and submit to Parks Canada Representative for approval before commencement of commissioning.
- .2 Start-up documentation to include:
  - .1 Factory and on-site test certificates for specified equipment.
  - .2 Pre-start-up inspection reports.
  - .3 Signed installation/start-up check lists.
  - .4 Start-up reports,

#### **1.16 TEST RESULTS**

- .1 If start-up, testing and/or PC produce unacceptable results, repair, replace or repeat specified starting and/or PC procedures until acceptable results are achieved.
- .2 Provide manpower and materials, assume costs for re-commissioning.

#### **1.17 START OF COMMISSIONING**

- .1 Notify Parks Canada Representative at least 10 days prior to start of Cx.

#### **1.18 INSTRUMENTS / EQUIPMENT**

- .1 Submit to Parks Canada Representative for review and approval:
  - .1 Complete list of instruments proposed to be used.
  - .2 Listed data including, serial number, current calibration certificate, calibration date, calibration expiry date and calibration accuracy.

**1.19 COMMISSIONING PERFORMANCE VERIFICATION**

- .1 Carry out Cx:
  - .1 Under actual operating conditions, over entire operating range, in all modes.
  - .2 On independent systems and interacting systems.
- .2 Cx procedures to be repeatable and reported results are to be verifiable.
- .3 Follow equipment manufacturer's operating instructions.
- .4 EMCS trending to be available as supporting documentation for performance verification.

**1.20 WITNESSING COMMISSIONING**

- .1 Parks Canada Representative to witness activities and verify results.

**1.21 AUTHORITIES HAVING JURISDICTION**

- .1 Where specified start-up, testing or commissioning procedures duplicate verification requirements of authority having jurisdiction, arrange for authority to witness procedures so as to avoid duplication of tests and to facilitate expedient acceptance of facility.
- .2 Obtain certificates of approval, acceptance and compliance with rules and regulation of authority having jurisdiction.
- .3 Provide copies to Parks Canada Representative within 5 days of test and with Cx report.

**1.22 DEFICIENCIES, FAULTS, DEFECTS**

- .1 Correct deficiencies found during start-up and Cx to satisfaction of Parks Canada Representative.
- .2 Report problems, faults or defects affecting Cx to Parks Canada Representative in writing. Stop Cx until problems are rectified. Proceed with written approval from Parks Canada Representative.

**1.23 COMPLETION OF COMMISSIONING**

- .1 Upon completion of Cx leave systems in normal operating mode.

**1.24 ACTIVITIES UPON COMPLETION OF COMMISSIONING**

- .1 When changes are made to baseline components or system settings established during Cx process, provide updated Cx form for affected item.

**1.25 TRAINING**

- .1 Ensure that training on new equipment is given to maintenance personnel.

**1.26 MAINTENANCE MATERIALS, SPARE PARTS, SPECIAL TOOLS**

- .1 Supply, deliver, and document maintenance materials, spare parts, and special tools as specified in contract.

**1.27 OWNER'S PERFORMANCE TESTING**

- .1 Performance testing of equipment or system by Parks Canada Representative will not relieve Contractor from compliance with specified start-up and testing procedures.

**2 PRODUCTS**

**2.01 NOT USED**

- .1 Not Used.

**3 EXECUTION**

**3.01 NOT USED**

- .1 Not Used.

**END OF SECTION**

## **1 GENERAL**

### **1.01 REFERENCES**

- .1 ASTM International
  - .1 ASTM A 53/A 53M-12, Standard Specification for Pipe, Steel, Black and Hot-Dipped, Zinc-Coated Welded and Seamless.
  - .2 ASTM A 269-14e1, Standard Specification for Seamless and Welded Austenitic Stainless Steel Tubing for General Service.
  - .3 ASTM A 325-10e1, Standard Specification for Carbon Steel Bolts and Studs, 120,000 PSI Tensile Strength.
- .2 CSA International
  - .1 CSA G40.20/G40.21-13, General Requirements for Rolled or Welded Structural Quality Steel/Structural Quality Steel.
  - .2 CAN/CSA G164-M92 (R2003), Hot Dip Galvanizing of Irregularly Shaped Articles.
  - .3 CSA S16-14, Design of Steel Structures.
  - .4 CSA W48-06, Filler Metals and Allied Materials for Metal Arc Welding (Developed in co-operation with the Canadian Welding Bureau).
  - .5 CSA W59-13, Welded Steel Construction (Metal Arc Welding).
- .3 Green Seal Environmental Standards (GS)
  - .1 GS-11-2008, 2nd Edition, Paints and Coatings.
- .4 Health Canada / Workplace Hazardous Materials Information System (WHMIS)
  - .1 Material Safety Data Sheets (MSDS).
- .4 The Master Painters Institute (MPI)
  - .1 Architectural Painting Specification Manual - current edition.

### **1.02 DOCUMENTS TO BE SUBMITTED FOR ACTION AND INFORMATION**

- .1 Submit documents in accordance with Section 01 33 00 - Submittal Procedures.
- .2 Product Data:
  - .1 Submit manufacturer's instructions, printed product literature and data sheets for pieces of equipment and material. Include product characteristics, performance criteria, physical size, finish and limitations.
  - .2 Submit copies of WHMIS MSDS in accordance with Section 01 35 29.06 - Health and Safety Requirements.
    - .1 For finishes, coatings, primers, and paints applied on site: indicate VOC concentration in g/L.
- .3 Shop Drawings:
  - .1 Submit drawings stamped and signed by professional engineer registered or licensed in Province of Quebec, Canada.
  - .2 Indicate materials, core thicknesses, finishes, connections, joints, welds, method of anchorage, number of anchors, supports, reinforcement, details, and accessories.

### **1.03 QUALITY ASSURANCE**

- .1 Test Reports: submit certified test reports showing compliance with specified performance characteristics and physical properties.
- .2 Certifications: submit product certificates signed by manufacturer certifying materials comply with specified performance characteristics and criteria and physical requirements.

### **1.04 DELIVERY, STORAGE AND HANDLING**

- .1 Deliver, store and handle materials in accordance with Section 01 61 00 – General Product Requirements and with manufacturer's written instructions.
- .2 Delivery and Acceptance Requirements: deliver materials to site in original factory packaging, labelled with manufacturer's name and address.
- .3 Storage and Handling Requirements:
  - .1 Store materials off ground in dry location and in accordance with manufacturer's recommendations in clean, dry, well-ventilated area.
  - .2 Replace defective or damaged materials with new.

## **2 PRODUCTS**

### **2.01 MATERIALS**

- .1 Steel sections and plates: to CSA G40.20/G40.21, Grade 300W or 350W according to drawings.
- .2 Welding materials: to CSA W59.
- .3 Welding electrodes: to CSA W48 Series.
- .4 Bolts and anchor bolts: to ASTM A 325.
- .5 Aluminum sheet: proprietary utility sheet.
- .6 Aluminum tubing, plate and shapes: 6061-T6.

### **2.02 METAL WORK - GENERAL**

- .1 Fabricate work square, true, straight and accurate to required size, with bolts closely fitted.
- .2 Where possible, fit and shop assemble work, ready for erection.
- .3 Ensure exposed welds are continuous over the entire length of each joint.

### **2.03 METAL WORK – MACHINE GUARDING**

- .1 All Work shall be executed in accordance with attached drawings and in compliance with requirements described in the CSST document titled “Machine guarding – Prevention of mechanical hazards” (DC-200-16002-1), latest revision, and according to standard CSA Z432-04.

- .2 The Contractor shall ensure, following the completion of installation Work, that no space exceeding the requirements described in the CSST document is the result of the Work and adjustments, in which case the Contractor shall pay to correct the safety barrier(s) in order to fill the opening according to standards.
- .3 If an on-site adjustment is required on protective covers covered by this contract, it will be possible to use the special glue on aluminium (or approved equivalent), as presented in the general notes (see drawing CCRL-M02), to avoid on-site welding. The Contractor shall comply with installation guidelines provided by the manufacturer.  
Note: Fall protection cannot be glued.
- .4 Glue shall only be use for on-site adjustment to close opening exceeding criteria as outlined in the CSST regulations.

Notice: The rails can't be glued.

## **2.04 FINISHES**

- .1 Galvanizing: hot dipped galvanizing with zinc coating 600 g/m<sup>2</sup> to CAN/CSA-G164.
- .2 Shop coat primer: MPI- EXT 5.1H in accordance with chemical component limits and restrictions requirements and VOC limits of GS-11 (DFT: 125 microns).
- .3 Zinc primer: zinc rich, ready mix to MPI-EXT 5.2C in accordance with chemical component limits and restrictions requirements and VOC limits of GS-11.
- .4 Two coats of semi-gloss finish paint (G5), in compliance with CAN/CGSB-1.118 (DFT: 125 microns), same colour as existing steel support.
- .5 Machined or polished surfaces should not be painted and must be protected by anti-corrosion materials prior to shipment to the site.

## **2.05 ISOLATION COATING**

- .1 Isolate aluminum from following components, by means of bituminous paint:
  - .1 Dissimilar metals except stainless steel, zinc, or white bronze of small area.
  - .2 Concrete, mortar and masonry.

## **2.06 SHOP PAINTING**

- .1 Rough welds and sharp edges should be smoothed by grinding. Burrs must be removed.
- .2 Steel surfaces should be polished without being skinned, with mechanical tool in accordance with SSPC- SP3 standard and cleaned according to SSPC -SP1 before applying paint.
- .3 Apply one shop coat of primer to metal items, with exception of galvanized or concrete encased items.
- .4 Use unadulterated paint, as indicated by manufacturer. Paint on dry surfaces, free from rust, scale, grease. Do not paint when temperature is lower than 7 degrees C.



- .5 Clean surfaces to be field welded; do not paint.

### **3 EXECUTION**

#### **3.01 EXAMINATION**

- .1 Verification of Conditions: verify conditions of substrates previously installed under other Sections or Contracts are acceptable for metal fabrications installation in accordance with manufacturer's written instructions.
  - .1 Visually inspect substrate in presence of Parks Canada Representative.
  - .2 Inform Parks Canada Representative of unacceptable conditions immediately upon discovery.

#### **3.02 ERECTION**

- .1 Do welding work in accordance with CSA W59 unless specified otherwise.
- .2 Erect metalwork square, plumb, straight, and true, accurately fitted, with tight bolts.
- .3 Supply and install appropriated fastening devices approved but the Ministry representative, such as stud and anchor rode.
- .4 Exposed fastening devices to match finish and be compatible with material through which they pass.
- .5 Supply components for work by other trades in accordance with shop drawings and schedule.
- .6 Assemble elements on site with either bolts or weld, depending on each connection, in accordance with CSA S16 standard.
- .7 Once the erection completed, touch-up field welds, bolts and burnt or scratched surfaces with;
  - .1 primer after completion of COV at 250 g/l at most, following the GS-11 standard.

#### **3.03 CLEANING**

- .1 Progress Cleaning: clean in accordance with Section 01 74 11 - Cleaning.
  - .1 Leave Work area clean at end of each day.
- .2 Final Cleaning: upon completion remove surplus materials, rubbish, tools and equipment in accordance with Section 01 74 11 - Cleaning.
- .3 Waste Management: separate waste materials for recycling in accordance with Section 01 74 21 - Construction/Demolition Waste Management and Disposal.
  - .1 Remove recycling containers and bins from site and dispose of materials at appropriate facility.

#### **3.04 PROTECTION**

- .1 Protect installed products and components from damage during construction.

- .2 Repair damage to adjacent materials caused by metal fabrications installation.

**END OF SECTION**

## **1 GENERAL**

### **1.01 SUMMARY**

- .1 Section content
  - .1 Materials and installation methods related to the replacement of mechanical equipment.

### **1.02 REFERENCES**

- .1 American National Standards Institute (ANSI).
  - .1 ANSI/NEMA MG 1-2003, Motors and Generators.
- .2 AGMA, American Gear Manufacturer Association

### **1.03 SYSTEM DESCRIPTION**

- .1 Mechanical work includes the replacement of equipment parts such as motor, gearbox, brake, fan, and coupling. The supply and installation of automated lubricating systems for open gears are also required.
- .2 The current motor 40HP will be kept for the works.
- .3 Lubrication system and supplies for exposed gears (inlet and outlet valves, vertical gate). The lubrication is done manually by the APC employees.

### **1.04 DESIGN REQUIREMENTS**

- .1 Motor 40 HO provided by APC type 3, 575 V, 1192 RPM, 60 Hz, frame 364 TC TEFC brand LEESON # cat C180897 serial # HAN005572, for vertical gate.
- .2 Adequate products
  - .1 Falk, Type G20
  - .2 Kop Flex, Waldron Gear Coupling
- .3 Provide new gear box as describe in drawing (M52). Adequate product or equivalent approved:
  - 1. Sew Eurodrive X3FS120HUB
- 4. Provide a new motor-brake, fan type, as described in the drawing (M52) to replace the existing motor-break. Adequate product or equivalent approved:
  - .1 Sheldons Engineering: 1316 FC PA arr. 4 class 5, OSHA inlet screen and guards
  - .2 Minimal capacity: 21.8 bhp
  - .3 Supply performance curve / fan test

- .5 Lubrication System
  - .1 The Contractor shall install automated lubrication LINCOLN-SKF P-203 system, provided by Parks Canada, and as described in Section 01 11 00 of this specification. The Contractor shall provide a performance warranty in writing of related equipment that shows compatibility with the automated lubrication system. A training session shall be given to Parks Canada Agency's maintenance technicians.
  - .2 The Contractor shall confirm the exact specific characteristics of open gears (main and pinion), such as diametral pitch, number of teeth and thickness, to be forwarded to the manufacturer of perforated lubrication gearboxes for lubrication systems; this applies to left and right sector gates, to inlet and outlet valves.
  - .3 The Contractor shall confirm the exact dimensions of lubricating pinions shown on drawings in order to confirm thickness, diametral pitch, number of required gear, number of teeth and final position including supports.
  - .4 The diameter, type and length of pipes between tanks/pumps and lubricating pinions shall be calculated to allow rated flow.
  - .5 The installer shall be qualified for the installation of specified equipment, and have relevant experience in this type of installation.
  - .6 The Contractor shall use an environmentally-friendly solvent to clean gear boxes and have his selection approved by the Parks Canada Representative.
  - .7 The Contractor shall use the type of lubrication indicated in the schematic diagram; lubrication will be supplied by Parks Canada. The Contractor shall ensure that lubrication is compatible with provided automated systems, accessories and piping.
  - .8 For the automated lubrication system, pivots and wheels (sector gates, inlet and outlet valves), the Contractor shall provide a distributor to control individual flow to each lubrication point.

#### **1.05 DOCUMENTS TO BE SUBMITTED FOR ACTION AND INFORMATION**

- .1 Submit the following documents in accordance with Section 01 33 00 - Submittal Procedures.
- .2 Provide product data in accordance with Section 01 33 00 - Submittal Procedures.
- .3 Shop drawings
  - .1 Submitted drawings shall indicate equipment layout, including details and the following information:
    - .1 Each submitted shop drawing shall be stamped and signed by a professional engineer registered or licensed in the Province of Quebec, Canada.
    - .2 Equipment specifications.
    - .3 Wiring diagrams.
- .4 Test Reports: Submit test reports issued by independent testing laboratories, certifying that the system meets the requirements for physical characteristics and performance criteria.
- .5 Certificates: Submit certificates signed by manufacturer certifying that materials, equipment and products meet the requirements for physical characteristics and performance criteria.
- .6 Instructions: Submit installation instructions provided by the manufacturer.
- .7 Documents/Items to be handed over upon work completion

- .1 Submit the following documents in accordance with Section 01 33 00 – SUBMITTAL PROCEDURES.
- .2 Project File
  - .1 Actual location of the equipment, names of manufacturers and of suppliers must be recorded in the project file.

#### **1.06 QUALITY CONTROL**

- .1 Qualifications
  - .1 Installer’s qualifications: for the installation of equipment prescribed in this section, use the services of a company that specializes in this type of work.
- .2 Health and safety
  - .1 Take the necessary measures with regard to health and safety in accordance with Section 01 35 29.06 – Health and Safety Requirements.

#### **1.07 DELIVERY, STORAGE AND HANDLING**

- .1 Deliver, store and handle materials in accordance with Section 01 61 00 - General Product Requirements and according to written manufacturer’s instructions.
- .2 Packaging, transportation, handling and unloading: deliver material in sealed original packaging, in good condition bearing undamaged identification labels.
- .3 Storage and protection: store material in temperate enclosures protecting it from bad weather conditions.
- .4 Waste Management and Disposal
  - .1 Separate waste materials for recycling in accordance with Section 01 74 21 - Construction/Demolition Waste Management and Disposal.
  - .2 Remove from site all packaging materials and transport them to appropriate recycling facilities.

#### **1.08 WARRANTY**

- .1 For each piece of equipment, provide a warranty period of 24 months from the scheduled commissioning.
- .2 Manufacturer Warranty: Submit to Parks Canada Representative, for consideration, the warranty of the manufacturer duly completed by the authorized officer of the company.

#### **2 PRODUCTS**

Not used

### **3 EXECUTION**

#### **3.01 INSTALLATION**

- .1 For each piece of equipment, install according to the manufacturer's instructions and ensure proper coupling's alignment. The contract shall provide an alignment report once the work is done.

#### **3.02 FIELD QUALITY CONTROL**

- .1 On-site inspection of assemblies by the Contractor according to his own procedures.

#### **3.03 COMMISSIONING TESTS**

- .1 Measuring devices must be calibrated and have a calibration certificate dated less than a year. Enter test results into a register.
- .2 Performance tests must show that the installation meets the performance requirements listed below:
  - .1 Movement of the gate is completed without any noise coming from the motor, coupling and gearbox.
  - .2 The motor is running at its rated speed, current is not overloaded.
  - .3 Opening and closing of the gate are fully executed as they were before the motor replacement.
  - .4 The motor-brake works as planned and the air flow variation by the adjustment louvers is easily done manually.
- .3 Following the connection of the new lubrication system, participate in the preoperational checks and commissioning of the unit and of the lubricating pinion together with the electrical contractor.
- .4 Without limitations, ensure the adjustment of the grease flow of the new system, ensure position adjustment of the lubricating pinion and ensure the proper operation of the lubrication system together with maintenance representatives and electrical contractor.
- .5 Perform testing according to Section 01 91 13 – General Commissioning Requirements.

#### **3.04 CLEANING**

- .1 Cleaning with an environmentally-friendly solvent is required for open gears.
- .2 Clean pieces of equipment for inspection purposes.
- .3 Cleaning during the Work period: perform cleaning in accordance with Section 01 74 11 – Cleaning.

**END OF SECTION**

## **1 GENERAL**

### **1.01 REFERENCES**

- .1 Canadian Standards Association (CSA International)
  - .1 CSA C22.1, Canadian Electrical Code, Part 1 (20th Edition), Safety Standard for Electrical Installations.
  - .2 CSA C22.2 No. 0.4 - Grounding of Electrical Equipment.
  - .3 CAN/CSA-C22.2 No. 0, General requirements - Canadian electrical code, part II
  - .4 CAN/CSA Z462-08 – Workplace Electrical Safety
  - .5 CAN3-C235-83(R2000), Preferred Voltage Levels for AC Systems, 0 to 50,000 V.
- .2 Electrical and Electronic Manufacturer's Association of Canada (EEMAC)
  - .1 EEMAC 2Y-1, Light Gray Colour for Indoor Switch Gear.
- .3 Institute of Electrical and Electronics (IEEE)/National Electrical Safety Code Product Line (NESC)
  - .1 IEEE SP1122-2000, The Authoritative Dictionary of IEEE Standards Terms, 7<sup>th</sup> Edition.

### **1.02 DEFINITIONS**

- .1 Electrical and electronic terms: unless otherwise specified or indicated, terms used in these specifications, and on drawings, are those defined by IEEE SP1122.

### **1.03 DESIGN REQUIREMENTS**

- .1 Operating voltages: to CAN3-C235.
- .2 Motors, electric heating, control and distribution devices and equipment to operate satisfactorily at 60 Hz within normal operating limits established by above standard.
  - .1 Equipment to operate in extreme operating conditions established in above standard without damage to equipment.
- .3 Language operating requirements: provide identification nameplates and labels for control items in English and French.
- .4 Elements that have the same functions shall be interchangeable. All electrical devices and accessories with the same functions must come from a single manufacturer.
- .5 Materials and equipment must be CSA certified. In cases where it is not possible to get CSA certified equipment, submit replacement materials and equipment to Supervisor or his representative before delivery to the site.

### **1.04 DOCUMENTS TO BE SUBMITTED FOR ACTION AND INFORMATION**

- .1 Submittals: in accordance with Section 01 33 00 - Submittal Procedures.
- .2 Shop drawings:
  - .1 Submit drawings stamped and signed by professional engineer registered or licensed in the Province of Quebec, Canada.
  - .2 Submit wiring diagrams and installation details of equipment indicating proposed

- location, layout and arrangement, control panels, accessories, piping, ductwork, and other items that must be shown to ensure coordinated installation.
  - .3 Identify on wiring diagrams circuit terminals and indicate internal wiring for each item of equipment and interconnection between each item of equipment.
  - .4 Indicate of drawings clearances for operation, maintenance, and replacement of operating equipment devices.
  - .5 Submit copies of drawings and product data to Parks Canada Representative.
  - .6 If changes are required, notify Parks Canada Representative of these changes before they are made.
- 
- .3 Quality Control: in accordance with Section 01 45 00 - Quality Control.
    - .1 Provide CSA certified equipment and material.
    - .2 Where CSA certified equipment and material is not available, submit such equipment and material to Parks Canada Representative for special approval before delivery to site.
    - .3 Submit test results of installed electrical systems and instrumentation.
    - .4 Permits and fees: in accordance with General Conditions of contract.
    - .5 Submit certificate of acceptance from authority having jurisdiction upon completion of Work to Parks Canada Representative.
  - .4 Manufacturer's Field Reports: submit to Parks Canada Representative manufacturer's written report, within 3 days of review, verifying compliance of Work and electrical system and instrumentation testing, as described in PART 3 - FIELD QUALITY CONTROL.

#### **1.05 QUALITY ASSURANCE**

- .1 Quality Assurance: in accordance with Section 01 45 00 - Quality Control.
- .2 Qualifications: electrical Work to be carried out by qualified, licensed electricians who hold valid Master Electrical Contractor license or apprentices in accordance with authorities having jurisdiction as per the conditions of Provincial Act respecting manpower vocational training and qualification.
  - .1 Employees registered in provincial apprentices program: permitted, under direct supervision of qualified licensed electrician, to perform specific tasks.
- .3 Site Meetings:
  - .1 Meetings at the request of Parks Canada Representative.
  - .2 Take necessary measures in terms of occupational health and safety on construction sites in accordance with Section 01 35 29.06 - Health and Safety Requirements.



### **1.06 DELIVERY, STORAGE AND HANDLING**

- .1 Material Delivery Schedule: provide Parks Canada Representative with schedule within 2 weeks after award of Contract.
- .2 Construction/Demolition Waste Management and Disposal: separate waste materials for recycling in accordance with Section 01 74 21 - Construction/Demolition Waste Management and Disposal.

### **1.07 SYSTEM START-UP**

- .1 Instruct Parks Canada Representative and operating personnel in operation, care and maintenance of systems, system equipment and components.
- .2 Provide these services for such period, and for as many visits as necessary to put equipment in operation, and ensure that operating personnel are conversant with aspects of its care and operation.

### **1.08 OPERATING INSTRUCTIONS**

- .1 Provide for each system and principal item of equipment as specified in technical sections for use by operation and maintenance personnel.
- .2 Operating instructions to include following:
  - .1 Wiring diagrams, control diagrams, and control sequence for each principal system and item of equipment.
  - .2 Start up, proper adjustment, operating, lubrication, and shutdown procedures.
  - .3 Safety precautions.
  - .4 Procedures to be followed in event of equipment failure.
  - .5 Other items of instruction as recommended by manufacturer of each system or item of equipment.
- .3 Print or engrave operating instructions and frame under glass or in approved laminated plastic.
- .4 Post instructions where directed.
- .5 For operating instructions exposed to weather, provide weather-resistant materials or weatherproof enclosures.
- .6 Ensure operating instructions will not fade when exposed to sunlight and are secured to prevent easy removal or peeling.

## **2 PRODUCTS**

### **2.01 MATERIALS AND EQUIPMENT**

- .1 Provide material and equipment in accordance with Section 01 61 00 - General Product Requirements.
- .2 Material and equipment to be CSA certified. Where CSA certified material and equipment is not available, obtain special approval from Parks Canada Representative before delivery to site and submit such approval as described in PART 1 - SUBMITTALS.
- .3 Factory assemble control panels and component assemblies.

**2.02 ELECTRIC MOTORS, EQUIPMENT AND CONTROLS**

- .1 Verify installation and co-ordination responsibilities related to motors, equipment and controls, as indicated.

**2.03 WARNING SIGNS**

- .1 Warning Signs: in accordance with requirements of Parks Canada Representative.

**2.04 WIRING TERMINATIONS**

- .1 Ensure lugs, terminals, screws used for termination of wiring are suitable for either copper or aluminum conductors.

**2.05 EQUIPMENT IDENTIFICATION**

- .1 Identify electrical equipment with nameplates and labels as follows:
  - .1 Nameplates: lamicoïd 3 mm thick plastic engraving sheet, matt white finish face, black core, lettering accurately aligned and engraved into core mechanically attached with self-tapping screws.
  - .2 Sizes as follows, or according to Parks Canada standards :

**NAMEPLATE SIZES**

Size 1	10 x 50 mm	1 line	3 mm high letters
Size 2	12 x 70 mm	1 line	5 mm high letters
Size 3	12 x 70 mm	2 lines	3 mm high letters
Size 4	20 x 90 mm	1 line	8 mm high letters
Size 5	20 x 90 mm	2 lines	5 mm high letters
Size 6	25 x 100 mm	1 line	12 mm high letters
Size 7	25 x 100 mm	2 lines	6 mm high letters

- .2 Labels: embossed plastic labels with 6 mm high letters unless specified otherwise.
- .3 Wording on nameplates and labels to be approved by Parks Canada Representative prior to manufacture.
- .4 Nameplates for terminal cabinets and junction boxes to indicate system and/or voltage characteristics.

## **2.06 WIRING IDENTIFICATION**

- .1 Identify wiring with permanent indelible identifying markings, coloured plastic tapes, on both ends of phase conductors of feeders and branch circuit wiring.
- .2 Maintain phase sequence and colour coding throughout.
- .3 Colour coding: to CSA C22.1.
- .4 Use colour coded wires in communication cables, matched throughout system.

## **2.07 FINISHES**

- .1 Envelopes metal surfaces must be finished in the workshop and be coated with a rust finish, inside and outside, and at least two layers of enamel finishing.
- .2 Switchgear cabinets and distribution installed inside must be painted light gray according to EEMAC 2Y -1 standard.

## **3 EXECUTION**

### **3.01 INSTALLATION**

- .1 Do complete installation in accordance with CSA C22.1 except where specified otherwise.

### **3.02 NAMEPLATES AND LABELS**

- .1 Ensure manufacturer's nameplates, CSA labels and identification nameplates are visible and legible after equipment is installed.

### **3.03 MOUNTING HEIGHTS**

- .1 Mounting height of equipment is from finished floor to centreline of equipment unless specified or indicated otherwise.
- .2 If mounting height of equipment is not specified or indicated, verify before proceeding with installation.

### **3.04 CO-ORDINATION OF PROTECTIVE DEVICES**

- .1 Ensure circuit protective devices such as overcurrent trips, relays and fuses are installed to required values and settings.

### **3.05 FIELD QUALITY CONTROL**

- .1 Perform tests in the presence of a Parks Canada Representative.
- .2 Provide measuring instruments, indicators, equipment and personnel required for carrying out the tests during the execution of works and completion thereof.

**3.06 CLEANING**

- .1 Clean and touch up surfaces of shop-painted equipment scratched or marred during shipment or installation, to match original paint.
- .2 Clean and prime exposed non-galvanized hangers, racks and fastenings to prevent rusting.

**END OF SECTION**

## **1 GENERAL**

### **1.01 REFERENCES**

- .1 Canadian Standards Association (CSA International)
  - .1 CAN/CSA-C22.2 No.18-98, Outlet Boxes, Conduit Boxes, Fittings and Associated Hardware.
  - .2 CSA C22.2 No.65-93(R1999), Wire Connectors.
- .2 Electrical and Electronic Manufacturers' Association of Canada (EEMAC)
  - .1 EEMAC 1Y-2, 1961 Bushing Stud Connectors and Aluminum Adapters (1200 Ampere Maximum Rating).
- .3 National Electrical Manufacturers Association (NEMA)

### **1.02 ITEMS TO BE SUBMITTED FOR ACTION**

- .1 In accordance with requirements described in PART 1.
- .2 Technical Product Data: For each type of indicated product.

## **2 PRODUCTS**

### **2.01 MATERIALS**

- .1 Pressure type wire connectors to: with current carrying parts of copper sized to fit copper conductors as required.
- .2 Bushing stud connectors: to EEMAC 1Y-2 to consist of:
  - .1 Connector body and stud clamp for stranded copper conductors.
  - .2 Clamp for stranded copper conductors.
  - .3 Clamp for stranded aluminum ACSR conductors.
  - .4 Stud clamp bolts.
  - .5 Bolts for copper conductors.
  - .6 Sized for conductors as indicated.
- .3 Clamps or connectors for armored cable, aluminum sheathed cable, mineral insulated cable, flexible conduit, non-metallic sheathed cable as required.

## **3 EXECUTION**

### **3.01 INSTALLATION**

- .1 Remove insulation carefully from ends of conductors and:
  - .1 Apply coat of zinc joint compound on aluminum conductors prior to installation of connectors.
  - .2 Install mechanical pressure type connectors and tighten screws with appropriate compression tool recommended by manufacturer. Installation shall meet secureness tests in accordance with CSA C22.2 No.65.

- .3 Install fixture type connectors and tighten. Replace insulating cap.
- .4 Install bushing stud connectors in accordance with EEMAC 1Y-2 and NEMA.

**END OF SECTION**

## **1 GENERAL**

### **1.01 REFERENCES**

- .1 CSA C22.2 N° 3, Electrical Features of Fuel-Burning Equipment.
- .2 CSA C22.2 N° 131 and 174, TECK90 type cables.

### **1.02 ITEMS TO BE SUBMITTED FOR ACTION**

- .1 In accordance with PART 1.
- .2 Technical Product Data: For each type of indicated product.

## **2 PRODUCTS**

### **2.01 TECK 90 CABLE**

- .1 Insulated copper twisted conductor, required size. Thermosetting polyethylene, cross-threads, RW90 and designed for a voltage of 300V, 600V and 1000V, as specified on drawings.
- .2 Incorporated grounding conductors.
- .3 Inner PVC jacket.
- .4 Protective metal armor protection in interlocked aluminum tape.
- .5 Overall covering: thermoplastic polyvinyl chloride, fireproof.
- .6 Fastenings:
  - .1 One hole aluminum straps to secure surface cables 50 mm and smaller. Two hole steel straps for cables larger than 50 mm.
  - .2 Channel type supports for two or more cables at 915 mm centers.
  - .3 Threaded rods: 6 mm diameter to support suspended channels.
- .7 Connectors:
  - .1 Watertight approved for TECK cables.

### **2.02 WELDING TYPE FLEXIBLE CABLES**

- .1 Connectors: suitable for cable type.
- .2 Multi-stranded copper conductors, size according to indications on drawings.

### **3 EXECUTION**

#### **3.01 FIELD QUALITY CONTROL**

- .1 Perform tests in accordance with Section 26 05 00 - General Electrical Requirements.
- .2 Perform tests using method appropriate to site conditions and to approval of Parks Canada Representative.
- .3 Perform tests before energizing electrical system.

#### **3.02 GENERAL CABLE INSTALLATION**

- .1 When required, remove the cables in existing cable trays.
- .2 When required, remove the cables in existing cable tunnels around the navigation lock , making sure to place them so that they are not damaged by tunnel covers or other elements.
- .3 Perform cable terminations in accordance with Section 26 05 20 – Wires and Box Connectors (0-1000 V).
- .4 Use color coded wires in accordance with Section 26 05 00 - General Electrical Requirements.

#### **3.04 INSTALLATION OF TECK90 CABLE (0 -1000 V)**

- .1 Group cables wherever possible on channels.
- .2 Install cable exposed, securely supported by staples, straps or hangers.

**END OF SECTION**



## **1 GENERAL**

### **1.01 REFERENCES**

- .1 American National Standards Institute (ANSI)/Institute of Electrical and Electronics Engineers (IEEE)
  - .1 ANSI/IEEE 837-1989(R1996), Qualifying Permanent Connections Used in Substation Grounding.
- .2 Canadian Standards Association, (CSA International)

## **2 PRODUCTS**

### **2.01 EQUIPMENT**

- .1 Ground clamps : size as indicated, to connect conductors to an electrically conductive underground water pipe.
- .2 Grounding conductors: bare stranded copper, tinned, soft annealed, suitably sized.
- .3 Insulated grounding conductors: green, RW90 type, suitably sized.
- .4 Ground bus: copper, size as indicated, complete with insulated supports, fastenings, connectors.
- .5 Non-corroding accessories necessary for grounding system, type, size, material as indicated, including but not necessarily limited to:
  - .1 Grounding and bonding bushings.
  - .2 Protective type clamps.
  - .3 Bolted type conductor connectors.
  - .4 Thermit welded type conductor connectors.
  - .5 Bonding jumpers, straps.
  - .6 Pressure wire connectors.

## **3 EXECUTION**

### **3.01 INSTALLATION GENERAL**

- .1 Install complete permanent, continuous grounding system including, electrodes, conductors, connectors and accessories.
- .2 Install connectors in accordance with manufacturer's instructions.
- .3 Protect exposed grounding conductors from being damaged.
- .4 Make buried connections, and connections to conductive water main, electrodes, using copper welding by thermit process permanent mechanical connectors or inspectable wrought copper compression connectors to ANSI/IEEE 837.

- .5 Use mechanical connectors for grounding connections to equipment provided with lugs.
- .6 Soldered joints not permitted.
- .7 Install bonding wire for flexible conduit, connected at both ends to grounding bushing, solderless lug, clamp or cup washer and screw. Neatly cleat bonding wire to exterior of flexible conduit.
- .8 Install flexible ground straps for bus duct enclosure joints, where such bonding is not inherently provided with equipment.
- .9 Bond single conductor, metallic armoured cables to cabinet at supply end, and provide non-metallic entry plate at load end and load end.
- .10 Ground secondary service pedestals.

### **3.02 SYSTEM AND CIRCUIT GROUNDING**

- .1 Install system and circuit grounding connections to neutral of primary 600V system, secondary 120/240V systems.

### **3.03 EQUIPMENT GROUNDING**

- .1 Install grounding connections to typical equipment included in, but not necessarily limited to following list. Service equipment, transformers, switchgear, duct systems, frames of motors, motor control centres, starters, control panels, building steel work, generators, elevators and escalators, distribution panels, outdoor lighting.

### **3.04 GROUNDING BUS**

- .1 Install copper grounding bus mounted on insulated supports on wall of electrical room.
- .2 Ground items of electrical equipment in electrical room to ground bus with individual bare stranded copper connections size 2/0AWG.

### **3.05 FIELD QUALITY CONTROL**

- .1 Perform tests in accordance with Section 26 05 00 - General Electrical Requirements.
- .2 Perform ground continuity and resistance tests using method appropriate to site conditions and to approval of Parks Canada Representative and local authority having jurisdiction over installation.
- .3 Perform tests before energizing electrical system.

**END OF SECTION**

## **1 GENERAL**

### **1.01 ITEMS TO BE SUBMITTED FOR ACTION**

- .1 In accordance with requirements described in PART 1.
- .2 Technical Product Data: For each type of indicated product.

## **2 PRODUCTS**

### **2.01 U-BEND CHANNELS**

- .1 U-bend channel, hot dip galvanized, surface mounted or suspended, complete with accessories and hardware.
- .2 Acceptable products:
  - .1 Superstrut, by Thomas and Betts or equivalent approved by Parks Canada Representative.

## **3 EXECUTION**

### **3.01 INSTALLATION**

- .1 Secure equipment to poured concrete with expandable inserts.
- .2 Support equipment, conduit or cables using clips, spring loaded bolts, cable clamps designed as accessories to basic channel members.
- .3 Suspended support systems.
  - .1 Support individual cable or conduit runs with 6 mm dia threaded rods and spring clips.
  - .2 Support 2 or more cables or conduits on channels supported by 6 mm dia threaded rod hangers where direct fastening to building construction is impractical.
- .4 For surface mounting of two or more conduits use channels at 1500 mm on centre spacing.
- .5 Provide metal brackets, frames, hangers, clamps and related types of support structures where indicated or as required to support conduit and cable runs.
- .6 Ensure adequate support for raceways and cables dropped vertically to equipment where there is no wall support.
- .7 Do not use wire lashing or perforated strap to support or secure raceways or cables.
- .8 Do not use supports or equipment installed for other trades for conduit or cable support except with permission of other trade and approval of Parks Canada Representative.
- .10 Install fastenings and supports as required for each type of equipment cables and conduits, and in accordance with manufacturer's installation recommendations.

**END OF SECTION**

## **1 GENERAL**

### **1.01 REFERENCES**

- .1 Boxes and fittings in accordance with CSA Standard C22.2 No. 18.

### **1.02 ITEMS TO BE SUBMITTED FOR ACTION**

- .1 Technical Product Data: For each type of indicated product.

## **2 PRODUCTS**

### **2.01 DIVIDING BOXES**

- .1 Construction: sheet metal enclosure, welded corners and formed hinged cover suitable for locking in closed position.
- .2 Terminations: connection blocks to match required size and number of incoming and outgoing conductors as indicated.
- .3 Spare Terminals: minimum three spare terminals on each connection or lug block sized less than 400 A.

### **2.02 JUNCTION AND PULL BOXES**

- .1 Steel boxes, welded, with flat screwed lids, free of sharp edges, for surface mounting as indicated on the drawings.
- .2 Covers with a rim of 25 mm (1 inch) at least, adaptable to flush-mounted pull and junction boxes.

### **2.03 ACCEPTABLE PRODUCTS**

- .1 Hoffman, Hammond or as indicated on electrical drawings or equivalent approved by Parks Canada Representative.

## **3 EXECUTION**

### **3.01 DIVIDING BOX INSTALLATION**

- .1 Mount plumb, true and square to building lines.
- .2 Extend dividing boxes on the entire length of equipment arrangement except where indicated otherwise.

### **3.02 CABINETS, JUNCTION AND PULL BOXES INSTALLATION**

- .1 Install pull boxes in inconspicuous but accessible locations.

- .2 Mount cabinets with top no higher than 2 m above finished floor except where indicated otherwise.
- .3 Only main junction and pull boxes are indicated. Install additional pull boxes as required by CSA C22.1.

**3.03 IDENTIFICATION**

- .1 Equipment Identification: in accordance to Section 26 05 00- General Electrical Requirements.

**END OF SECTION**

## **1 GENERAL**

### **1.01 REFERENCES**

- .1 Canadian Standards Association (CSA)/ CSA International.
  - .1 Airbrake switches, manually operable, enclosed, for use in nonhazardous locations and sudden power failure in accordance with CSA C22.2 No. 4 - M89 requirements.
  - .2 Fuse holders in accordance with CSA Standard C22.2 No. 39 M1987 c1992 requirements.

### **1.02 ITEMS TO BE SUBMITTED FOR ACTION**

- .1 In accordance with requirements described in PART 1.
- .2 Technical Product Data: For each type of indicated

## **2 PRODUCTS**

### **2.01 DISCONNECT SWITCHES**

- .1 All switches shall be supplied by the same manufacturer.
- .2 Switch size as indicated.
- .3 Lockable in "closed" or "open" position using three (3) padlocks.
- .4 Mechanical interlock door that can be open only when the lever is in "closed" position.
- .5 Fuses: size as indicated.
- .6 The fuse holders of disconnect switch must be suitable, without an adapter, to the determined fuse category, as indicated .
- .7 Snap closing and sudden power failure mechanism.
- .8 Identify "OPEN" and "CLOSED" positions on the box cover.

### **2.02 EQUIPMENT IDENTIFICATION**

- .1 Provide equipment identification in accordance with Section 26 05 00 - General Electrical Requirements.

### **2.03 ACCEPTABLE PRODUCTS**

- .1 Schneider or approved equivalent by Parks Canada Representative.

**3 EXECUTION**

**3.01 INSTALLATION**

- .1 Install disconnect switches, and, when applicable, fuses, according to the manufacturer's instructions and according to drawings.

**END OF SECTION**

## **1 GENERAL**

### **1.01 REFERENCES**

- .1 American National Standards Institute
  - .1 ANSI J-STD-607-A-2002, Joint Standard - Commercial Building Grounding (Earthing) and Bonding Requirements for Telecommunications.
- .2 Telecommunications Industries Association (TIA)/Electronic Industries Alliance (EIA)
  - .1 TIA/EIA-606-2002, Administration Standard for the Commercial Telecommunications Infrastructure.
- .3 U.S. Department of Labor/Occupational Safety and Health Administration (OSHA)
  - .1 Nationally Recognized Testing Laboratory (NRTL) (Laboratoire d'essais reconnu à l'échelle nationale).
- .4 Association canadienne de normalisation (CSA)/CSA International
  - .1 CSA-C22.2 numéro 214-F02, Câbles de télécommunications (norme binationale avec UL 444).
  - .2 CSA-C22.2 numéro 232-FM1988 (C2004), Câbles optiques.
- .5 Telecommunications Industry Association (TIA)/Electronic Industries Alliance (EIA)
  - .1 TIA/EIA-568-B.1-(2001), Commercial Building Telecommunications Cabling Standard, Part 1: General Requirements.
  - .2 TIA/EIA-568-B.2-(2001), Commercial Building Telecommunications Cabling Standard, Part 2: Balanced Twisted-Pair Cabling Components.
  - .3 TIA/EIA-568-B.3-(2000), Optical Fiber Cabling Components Standard.
  - .4 TIA/EIA-606-A-(2002), Administration Standard for the Commercial Telecommunications Infrastructure.
  - .5 TIA TSB-140-2004, Telecommunications Systems Bulletin - Additional Guidelines for Field-Testing Length, Loss and Polarity of Optical Fiber Cabling Systems.
  - .6 TIA-598-C-(2005), Optical Fiber Cable Color Coding.1.03

### **1.02 SYSTEM DESCRIPTION**

- .1 General

The network infrastructure implemented will allow to control and visualize the different lubrication systems of the Carillon navigation lock. This network will be connected to the existing main PLC and supervision network of the lock. All implemented equipment shall meet the safety standard as required by the Parks Canada Representative.
- .2 Wells and vertical gate

Optic fiber cables (24 duplex fiber, 62.5/125µm, Multimode) allowing communication between each well are existing, but not connected. The connection between these existing cables will be done directly into the local junction boxes with patch cords. Since there are 2 terminal blocks by optic fiber box in each well, each terminal block will be used to connect each optic fiber cable when required. An adequate identification for each cable and each optic fiber is required to allow a quick repair.



.03 Navigation lock electrical room

A fiber patch panel shall be installed in the existing rack to connect every optic fiber of the all wells. A new Ethernet switch shall be installed in the rack for connection between all optic fiber cables and the existing Ethernet Switch in the rack.

**1.03 DEFINITIONS**

- .1 Refer to definition « optical-fiber interconnect, distribution and breakout cables » presented in the annex A of the TIA/EIA-598-C.

**1.04 DESIGN REQUIREMENTS**

- .1 Operating voltages: to CAN3-C235.
- .3 Language operating requirements: provide identification nameplates and labels for control items in English and French.
- .4 Elements that have the same functions shall be interchangeable. All electrical devices and accessories with the same functions must come from a single manufacturer.
- .5 Materials and equipment must be CSA certified. In cases where it is not possible to get CSA certified equipment, submit replacement materials and equipment to the Ministry Representative before delivery to the site.

**1.05 DOCUMENTS TO BE SUBMITTED FOR ACTION AND INFORMATION**

- .1 Submittals: in accordance with Section 01 33 00 - Submittal Procedures.
- .2 Shop drawings:
  - .1 Submit drawings stamped and signed by professional engineer registered or licensed in the Province of Quebec, Canada.
  - .2 Submit connection diagrams and installation details of equipment indicating proposed location, layout and arrangement, control panels, accessories, piping, ductwork, and other items that must be shown to ensure coordinated installation.
  - .3 Identify on connection diagrams circuit terminals and indicate internal wiring for each item of equipment and interconnection between each item of equipment.
  - .4 Indicate of drawings clearances for operation, maintenance, and replacement of operating equipment devices.
  - .5 Submit copies of drawings and product data to the Ministry Representative.
  - .6 If changes are required, the Ministry Representative of these changes before they are made.
- .3 Quality Control:
  - .1 Provide CSA certified equipment and material.
  - .2 Where CSA certified equipment and material is not available, submit such equipment and material to the Ministry Representative for special approval before delivery to site.
  - .3 Submit test results of installed electrical systems and telecommunication instruments as well as all network connections made on site.
  - .4 Permits and fees: in accordance with General Conditions of contract.
  - .5 Submit certificate of acceptance from authority having jurisdiction upon completion of Work to Ministry Representative.
- .4 Manufacturer's Field Reports: submit to Parks Canada Representative manufacturer's written report, within 3 days of review, verifying compliance of Work and electrical system and instrumentation testing, as described in PART 3 - FIELD QUALITY CONTROL.

- .1 Quality Assurance: in accordance with Section 01 45 00 - Quality Control.
- .2 Permitted activities: determined based on training level attained and demonstration of ability to perform specific duties.
- .3 Site Meetings:
  - .1 Meetings at the request of Ministry Representative.
  - .2 Take necessary measures in terms of occupational health and safety on construction sites in accordance with Section 01 35 29.06 - Health and Safety Requirements.

#### **1.07 DELIVERY, STORAGE AND HANDLING**

- .1 Material Delivery Schedule: provide the Ministry Representative with schedule within 2 weeks after award of Contract.
- .2 Construction/Demolition Waste Management and Disposal: separate waste materials for recycling in accordance with Section 01 74 21 - Construction/Demolition Waste Management and Disposal.

#### **1.08 SYSTEM STARTUP**

- .1 Instruct Parks Canada Representative and operating personnel in operation, about the care and maintenance of systems, system equipment and components.
- .2 Arrange and pay for services of manufacturer's factory service engineer to supervise start-up of installation, check, adjust, balance and calibrate components and instruct operating personnel.
- .3 Provide these services for such period, and for as many visits as necessary to put equipment in operation, and ensure that operating personnel are conversant with aspects of its care and operation.
- .4 Provide a list of all the software installed on the operating stations as well as all required license number and passwords if applicable.
- .5 Provide all the required software for the configuration as well as the maintenance of the telecommunication equipment's provided.

#### **1.09 OPERATING INSTRUCTIONS**

- .1 Provide for each system and principal item of equipment as specified in technical sections for use by operation and maintenance personnel.
- .2 Operating instructions to include following:
  - .1 Wiring diagrams, control diagrams, and control sequence for each principal system and item of equipment.
  - .2 Start up, proper adjustment, operating, and shutdown procedures.
  - .3 Safety precautions.
  - .4 Procedures to be followed in event of equipment failure.
  - .5 Other items of instruction as recommended by manufacturer of each system or item of

- .3 Print or engrave operating instructions and frame under glass or in approved laminated plastic.
- .4 Post instructions where directed.

## **2 PRODUCTS**

### **2.01 MATERIALS AND EQUIPMENT**

- .1 Provide material and equipment in accordance with Section 01 61 00 - Common Product Requirements.
- .2 Material and equipment to be CSA certified. Where CSA certified material and equipment is not available, obtain special approval from Ministry Representative before delivery to site and submit such approval as described in section 01 33 00.
- .3 Factory assemble control panels and component assemblies.

### **2.02 POLYETHYLENE INSULATED CABLES**

- .1 Conductors 26 AWG soft copper made into cables as follows:
  - .1 Number of pairs: 4.
  - .2 Polyethylene, electric grade insulation.
  - .3 Non-hygroscopic coloured binders.
  - .4 Sheath:
    - .1 Flat aluminum tape formed longitudinally and lapped with outer jacket of extruded polyethylene.
    - .2 Inner polyethylene jacket, flat aluminum tape and outer polyethylene jacket.
    - .3 Inner polyethylene jacket, corrugated aluminum tape not overlapped, and soldered, with covering of thermoplastic compound and jacket of polyethylene.
    - .4 Inner polyethylene jacket, layer of spirally wound paper tape and extruded lead sheath.

### **2.03 TELECOMMUNICATIONS GROUNDING BUSBAR (TGB)**

- .1 Predrilled copper busbar, with holes 8 mm diameter for use with standard-sized lugs to: ANSI J-STD-607-A.
- .2 Dimensions 6 mm thick, 50 mm wide as required by: ANSI J-STD-607-A.

### **2.04 WARNING SIGNS**

- .1 Warning Signs: in accordance with requirements of Ministry Representative.

### **2.05 PATHWAYS FOR COMMUNICATION**

- .1 Cable Teck 90 type, in accordance with Section 26 05 21 – Cables and wiring (0 – 1000V).

- .1 Identify electrical equipment with nameplates and labels as follows:
  - .1 Nameplates: lamicoïd 3 mm thick plastic engraving sheet, matt white finish face, black core, lettering accurately aligned and engraved into core mechanically attached with self tapping screws.
  - .2 Sizes as follows, or according to Parks Canada standards:

**NAMEPLATE SIZES**

Size 1	10 x 50 mm	1 line	3 mm high letters
Size 2	12 x 70 mm	1 line	5 mm high letters
Size 3	12 x 70 mm	2 lines	3 mm high letters
Size 4	20 x 90 mm	1 line	8 mm high letters
Size 5	20 x 90 mm	2 lines	5 mm high letters
Size 6	25 x 100 mm	1 line	12 mm high letters
Size 7	25 x 100 mm	2 lines	6 mm high letters

- .2 Labels: embossed plastic labels with 6 mm high letters unless specified otherwise.
- .3 Wording on nameplates and labels to be approved by Ministry Representative prior to manufacture.
- .4 Nameplates for terminal cabinets and junction boxes to indicate system and/or voltage characteristics.

**2.06 WIRING IDENTIFICATION**

- .1 Identify wiring with permanent indelible identifying markings, coloured plastic tapes, on both ends of phase conductors of feeders and branch circuit wiring.
- .2 Maintain phase sequence and colour coding throughout.
- .3 Colour coding: to CSA C22.1.
- .4 Use colour coded wires in communication cables, matched throughout system.

**2.07 FINISHES**

- .1 Envelopes metal surfaces must be finished in the workshop and be coated with a rust finish, inside and outside, and at least two layers of enamel finishing.
- .2 Switchgear cabinets and distribution installed inside must be painted light gray according to EEMAC 2Y -1 standard.

**3 EXECUTION**

**3.01 INSTALLATION**

- .1 Do complete installation in accordance with CSA C22.1 except where specified otherwise.

**3.02 TELECOMMUNICATIONS GROUNDING BUSBAR (TGB)**

- .1 Install TGB in main terminal/equipment room and each telecommunications room.
- .2 Install copper bonding conductor from TGB to enclosure of serving electrical power panel (panelboard).

**3.03 BONDING CONDUCTORS GENERAL**

- .1 When placed in ferrous metallic conduit or EMT longer than 1 m, bond to each end of conduit or EMT.

**3.04 BONDING CONDUCTOR FOR TELECOMMUNICATIONS**

- .1 Install bonding conductor for telecommunications from TGB to service equipment (power) ground.
- .2 Use exothermic welding, approved 2 hole compression lugs for connection to TGB.

**3.05 PATHWAYS FOR COMMUNICATION**

- .1 Install empty raceway system, including distribution system, fish wire, terminal cabinets, outlet boxes, floor boxes, pull boxes, cover plates, conduit, sleeves and caps, cabletroughs, service poles, miscellaneous and positioning material to constitute complete system.

**3.06 NAMEPLATES AND LABELS**

- .1 Ensure manufacturer's nameplates, CSA labels and identification nameplates are visible and legible after equipment is installed.

**3.07 MOUNTING HEIGHTS**

- .1 Mounting height of equipment is from finished floor to centreline of equipment unless specified or indicated otherwise.
- .2 If mounting height of equipment is not specified or indicated, verify with the ministry representative before proceeding with installation.

**3.08 CO-ORDINATION OF PROTECTIVE DEVICES**

- .1 Ensure circuit protective devices such as overcurrent trips, relays and fuses are installed to required values and settings.

**3.09 FIELD QUALITY CONTROL**

- .1 Perform tests in the presence of the Ministry Representative.
- .2 Provide measuring instruments, indicators, equipment and personnel required for carrying out the tests during the execution of works and completion thereof.

- .1 At the workshop, clean and touch up painted surfaces that were scratched or damaged during transportation and installation; use paint of the same type and identical colour as the original paint.
- .2 Clean hooks, supports, fastenings and other apparent non-galvanized fastening devices, and apply primer to prevent rust.

**END OF SECTION**

## **1 GENERAL**

### **1.01 REFERENCES**

- .1 Canadian Standards Association (CSA International)
  - .1 CSA-C22.2 No. 214-02, Communications Cables (Bi-National standard with UL 444).
  - .2 CSA-C22.2 No. 232-M1988(R2004), Optical Fiber Cables.
- .2 Telecommunications Industry Association (TIA)/Electronic Industries Alliance (EIA)
  - .1 TIA/EIA-568-B.1-(2001), Commercial Building Telecommunications Cabling Standard, Part 1: General Requirements.
  - .2 TIA/EIA-568-B.2-(2001), Commercial Building Telecommunications Cabling Standard, Part 2: Balanced Twisted-Pair Cabling Components.
  - .3 TIA/EIA-568-B.3-(2000), Optical Fiber Cabling Components Standard.
  - .4 TIA/EIA-606-A-(2002), Administration Standard for the Commercial Telecommunications Infrastructure.
  - .5 TIA TSB-140-2004, Telecommunications Systems Bulletin - Additional Guidelines for Field-Testing Length, Loss and Polarity of Optical Fiber Cabling Systems.
  - .6 TIA-598-C-(2005), Optical Fiber Cable Color Coding.

### **1.02 DEFINITIONS**

- .1 Refer to TIA/EIA-598-C, Annex A for definitions of terms: optical-fiber interconnect, distribution, and breakout cables.

### **1.03 SYSTEM DESCRIPTION**

- .1 The structured telecommunications wiring system consists of unshielded-twisted-pair and optical fiber cables, terminations, connectors, cross-connection hardware and related equipment installed inside the building for occupant's telecommunications systems, including voice (telephone), data, and image.

### **1.04 DOCUMENTS TO BE SUBMITTED FOR ACTION AND INFORMATION**

- .1 Provide submittals in accordance with Section 01 33 00 - Submittal Procedures.
- .2 As-built records and drawings.

### **1.05 QUALITY ASSURANCE**

- .1 Health and Safety Requirements: construction occupational health and safety in accordance with Section 01 35 29.06 - Health and Safety Requirements.

### **1.06 DELIVERY, STORAGE AND HANDLING**

- .1 Waste Management and Disposal: separate waste materials for reuse and recycling in accordance with Section 01 74 21 - Construction/Demolition Waste Management and Disposal.

## **2 PRODUCTS**

### **2.01 FOUR-PAIR 100 Ω BALANCED TWISTED PAIR CABLE**

- .1 Four-pair, 100 ohm balanced unshielded-twisted-pair (UTP) cable category 6 (Cat 6) enhanced to: TIA/EIA-568-B.2.

### **2.02 WORK AREA UTP 4-PAIR MODULAR JACK**

- .1 Eight-position modular jack ("RJ-45"), category 6 to: TIA/EIA-568- B.2:
  - .1 In self-contained surface-mount box, one (1) jack per box.
  - .2 Mounted in compatible single jack position per faceplate.

### **2.03 UTP CROSS-CONNECT WIRE**

- .1 Category 6, 4-pair cable to: TIA/EIA-568-B.2.

### **2.04 UTP PATCH CORDS**

- .1 With factory-installed male plug at one end to mate with terminal strip and with factory-installed male plug at other end to mate with terminal strip Category 6, 4-pair to: TIA/EIA-568-B.2.

### **2.05 UTP EQUIPMENT CABLE**

- .1 4-pair "pigtail", with factory-installed male plug on one end to mate with "RJ-45" jack and other end equipped with factory-installed male plug to mate with terminal strip category 6 to: TIA/EIA-568-B.2.

### **2.06 UTP WORK AREA CORDS**

- .1 3 metre long, each end equipped with "RJ-45" plug category 6 to: TIA/EIA-568-B.2.

### **2.07 OPTICAL-FIBER CABLE**

- .1 Distribution, without conductive members, multi-mode 50/125, 500 MHz km capacity 62.5/125 micron strands to: CSA-C22.2 No. 232 and TIA/EIA-568- B.3, one end terminated with duplex SC connector and the other end terminated with duplex LC.

## **3 EXECUTION**

### **3.01 INSTALLATION OF TERMINATION AND CROSS-CONNECT HARDWARE**

- .1 Install termination and cross-connect hardware as indicated and according to manufacturers' instructions. Identify and label as indicated to: TIA/EIA-606-A.

### **3.02 INSTALLATION OF HORIZONTAL DISTRIBUTION CABLES**

- .1 Install horizontal cables as indicated in cable trays from telecommunication rooms to individual work-area jacks. Identify and label as indicated to: TIA/EIA-606-A.
- .2 Support horizontal cables at intervals not exceeding two (2) metres.



- .3 Install horizontal cables from consolidation point to individual work-area jacks.
  - .1 Provide supplementary "J" hooks to support cables at intervals not exceeding two (2) metres.
  - .2 Identify and label as indicated to: TIA/EIA-606-A.
- .4 Terminate horizontal cables in telecommunications room and at individual work-area jacks.
  - .1 Identify and label as indicated to: TIA/EIA-606-A.
- .5 Harness slack cable in cabinets, racks, and wall-mounted termination and cross-connection hardware.

### **3.03 INSTALLATION OF EQUIPMENT CABLES**

- .1 Install equipment cables from equipment patch panel as indicated.
  - .1 Identify and label as indicated to: TIA/EIA-606-A.

### **3.04 IMPLEMENT CROSS-CONNECTIONS**

- .1 Implement cross-connections using patch cords as specified.

### **3.05 FIELD QUALITY CONTROL**

- .1 Test horizontal UTP cables as specified below and correct deficiencies provide record of results as hard copy.
  - .1 Perform tests for Permanent Link on installed cables, including spares:
    - .1 Category 6 using certified level III tester to: TIA/EIA-568-B.2.
- .2 Test Optical-fiber strands for attenuation to: TIA/EIA-568-B.1 and correct deficiencies: provide record of results as hard copy.
  - .1 Test horizontal links need at only one wavelength (850 nm or 1300 nm) and in one direction.
    - .1 Attenuation to be less than 2.0 dB, unless consolidation point is used.
    - .2 If consolidation point is used, attenuation test result to be less than 2.75 dB when testing between horizontal cross-connect and telecommunications outlet/connector.
  - .2 Test backbone links in both directions. Backbone links:
    - .1 Test multi-mode fiber at both applicable wavelengths (850 nm and 1300 nm).
    - .2 Test single-mode fiber at both applicable wavelengths (1550 nm and 1310 m).
  - .3 Maximum attenuation: Cable attenuation + Connector loss + Splice loss.
    - .1 Multi-mode-fiber attenuation coefficients:
      - .1 3.5 db/km @ 850 nm; and
      - .2 1.5 db km @ 1300 nm
    - .2 Single-mode fiber attenuation coefficients at both 1310 nm and 1550 nm:
      - .1 1.0 db/km for inside plant cable; and
      - .2 0.5 db/km for outside plant cables.
    - .3 Maximum connector insertion loss: 0.75 db per pair and maximum splice insertion loss: 0.3 db.

**END OF SECTION**

**PARKS CANADA  
MACHINE GUARDING INSTALLATION AND  
MECHANICAL & ELECTRICAL COMPONENTS REPLACEMENT  
AT THE CARILLON NAVIGATION LOCK**

**ANNEX A**

**ANNEX A – REFERENCE DRAWINGS**



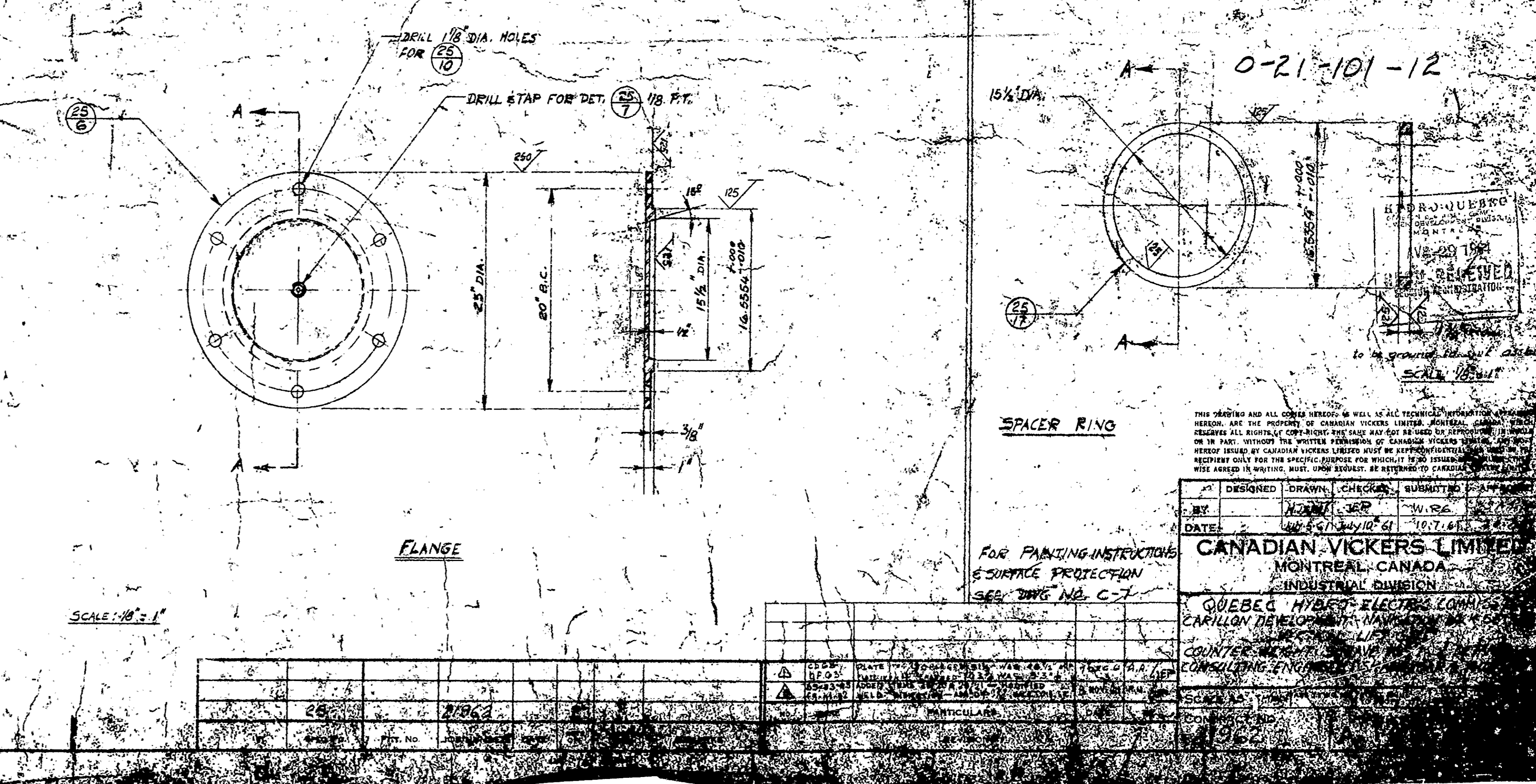
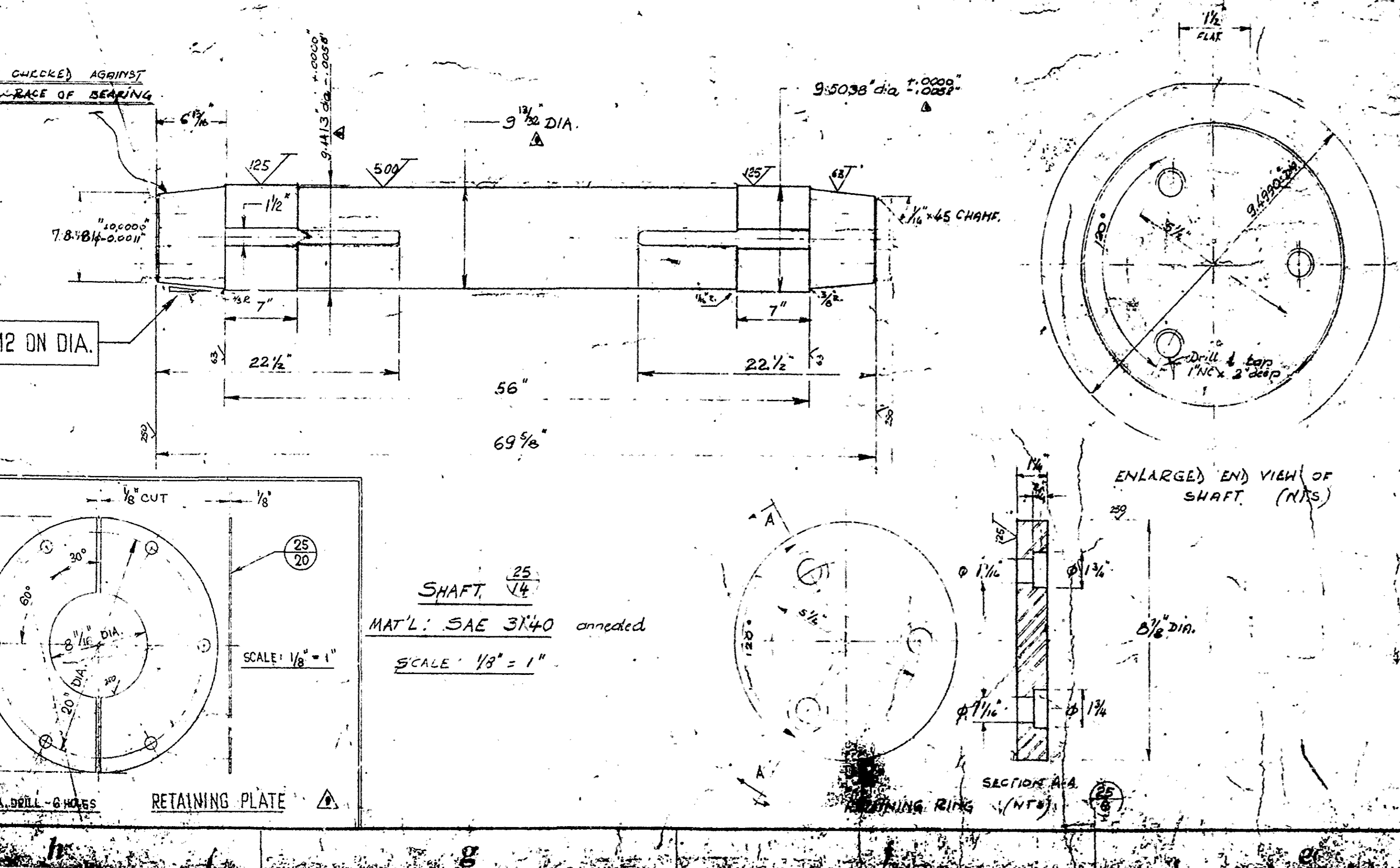
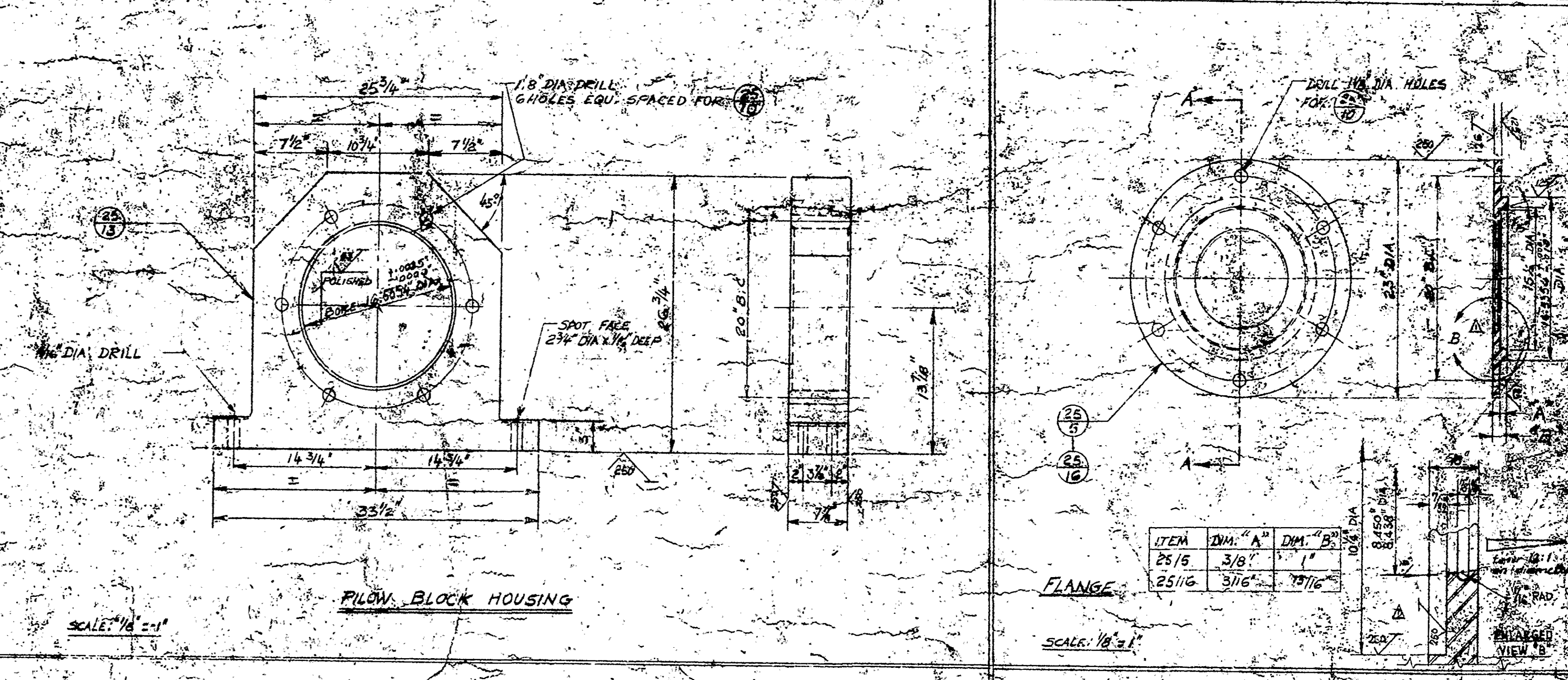
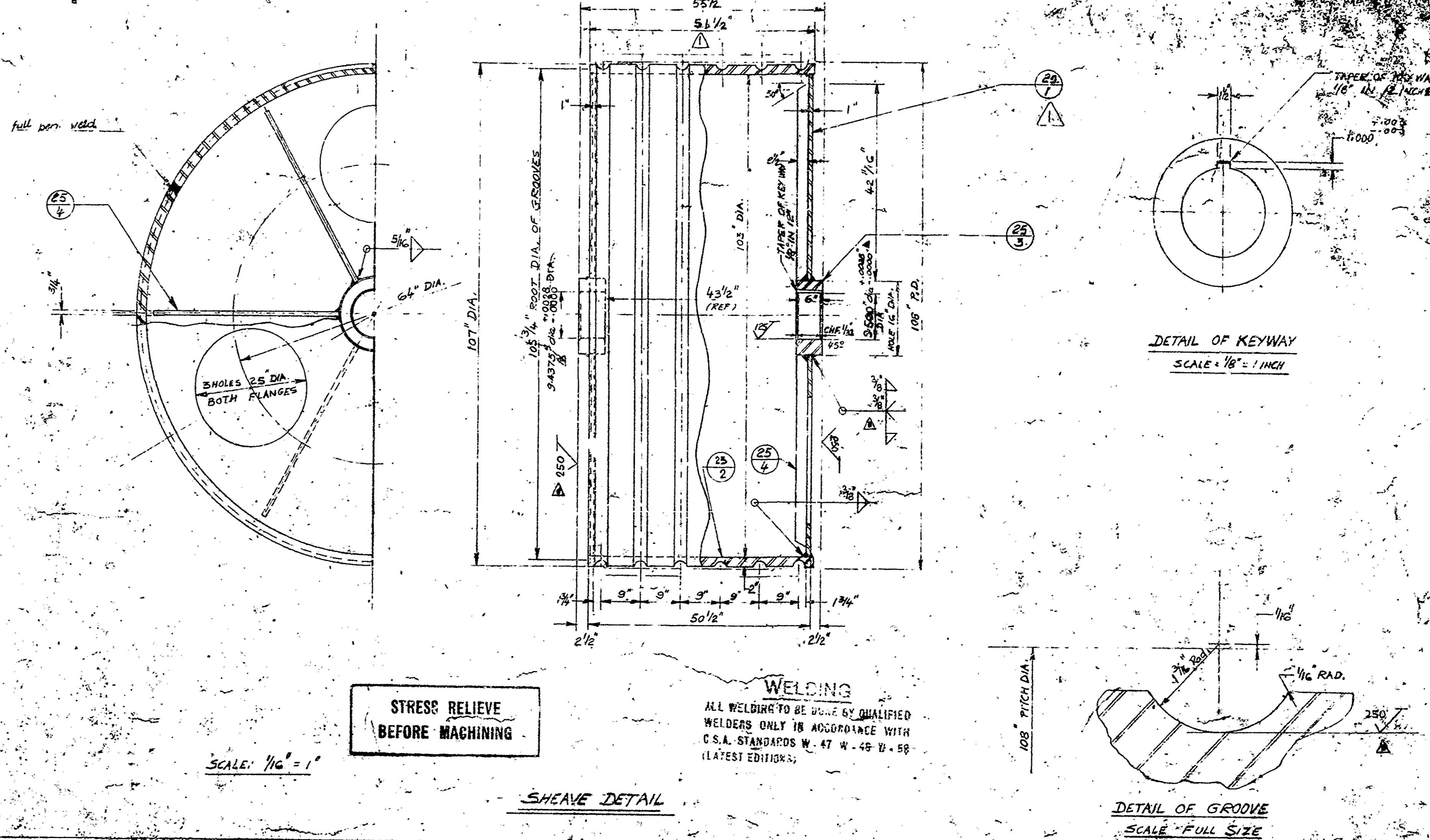
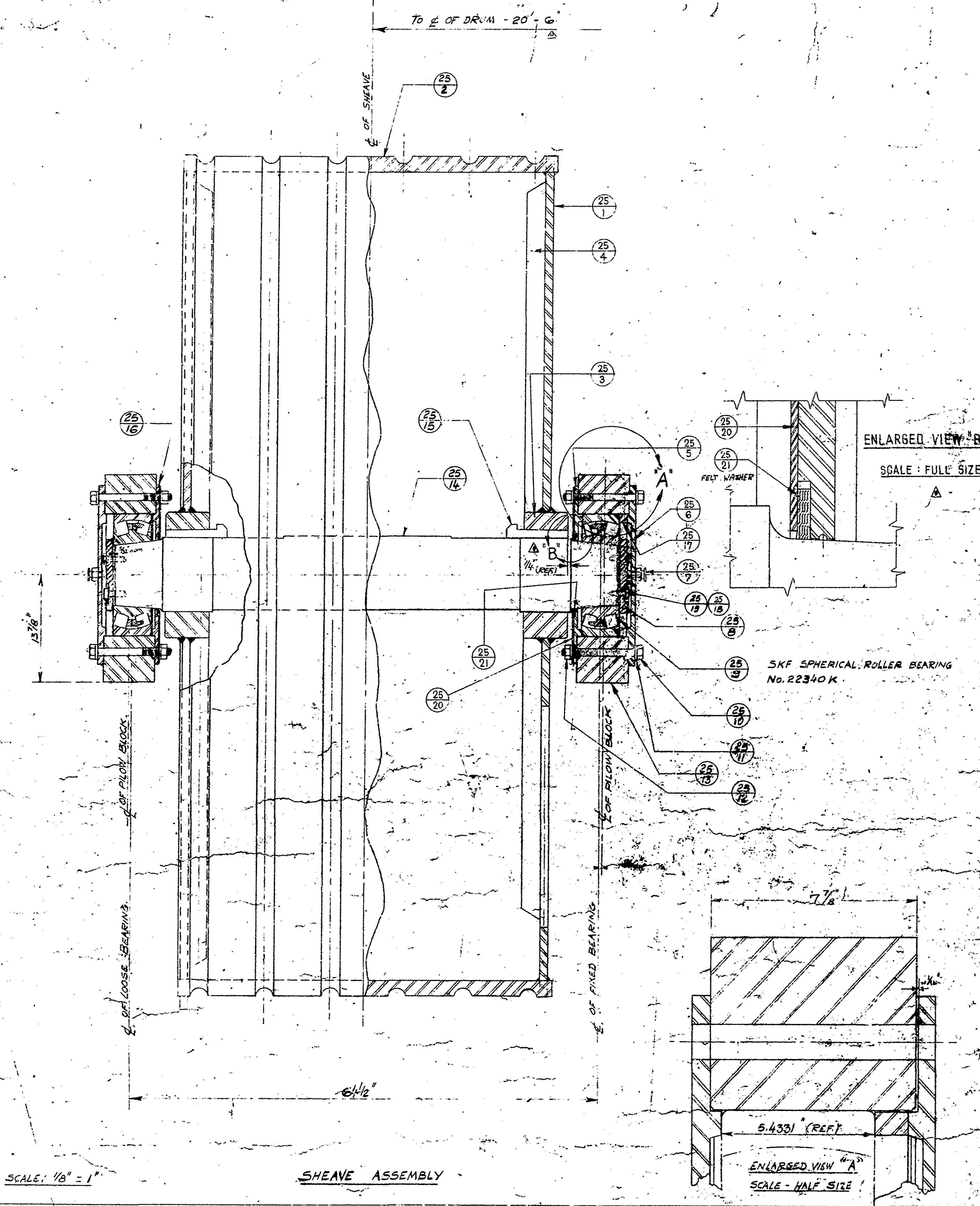

- NOTE -  
The legibility of this drawing is substandard and may result in poor microfilm reproduction.



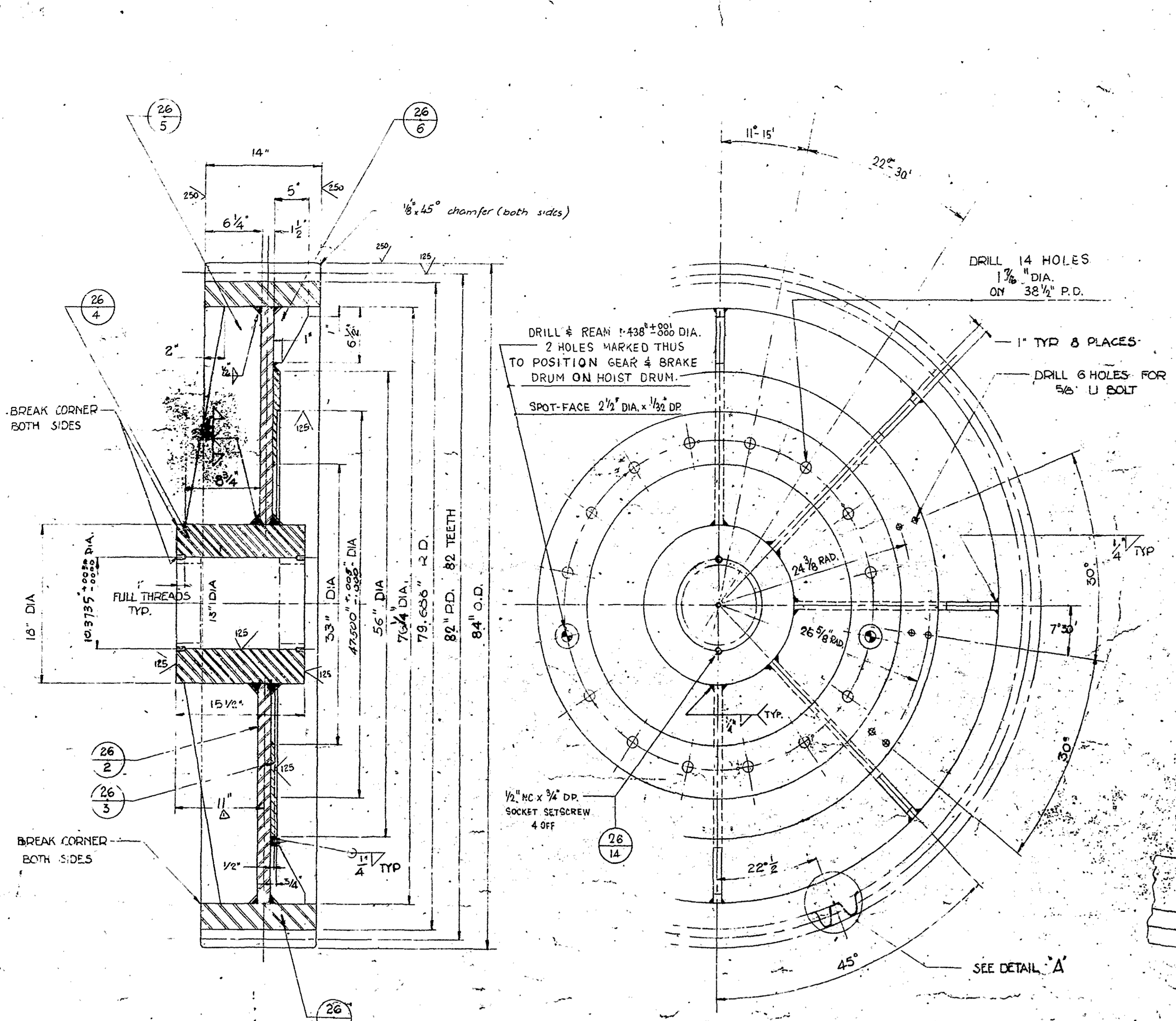

MAT. OF RIM: FM 222  
 BHN of teeth: 205-215  
 UTS: 85000 psi min

SCALE: 1 1/2" = 1'-0"

GEAR	CUTTING	DATA
ADD. CLASS	FACE WIDTH	14"
CUT ON	ADDENDUM	1.000
TYPE OF TEETH	FULL DEPTH	ADDENDUM RATIO
HELIX ANGLE	TOOTH CALIPER HEIGHT	
PRESSURE ANGLE	TOOTH CALIPER THICKNESS	
NO. OF TEETH	BACKLASH TOTAL	.025-.040
PITCH	TOOTH MATING GEAR	15
PITCH DIA.	CENTRE DISTANCE	82.000
OUTSIDE DIA.	OR NON STANDARD RATIO	84.000
ROOT DIA.	SHAFTS PARALLEL OR NOT	PARALLEL

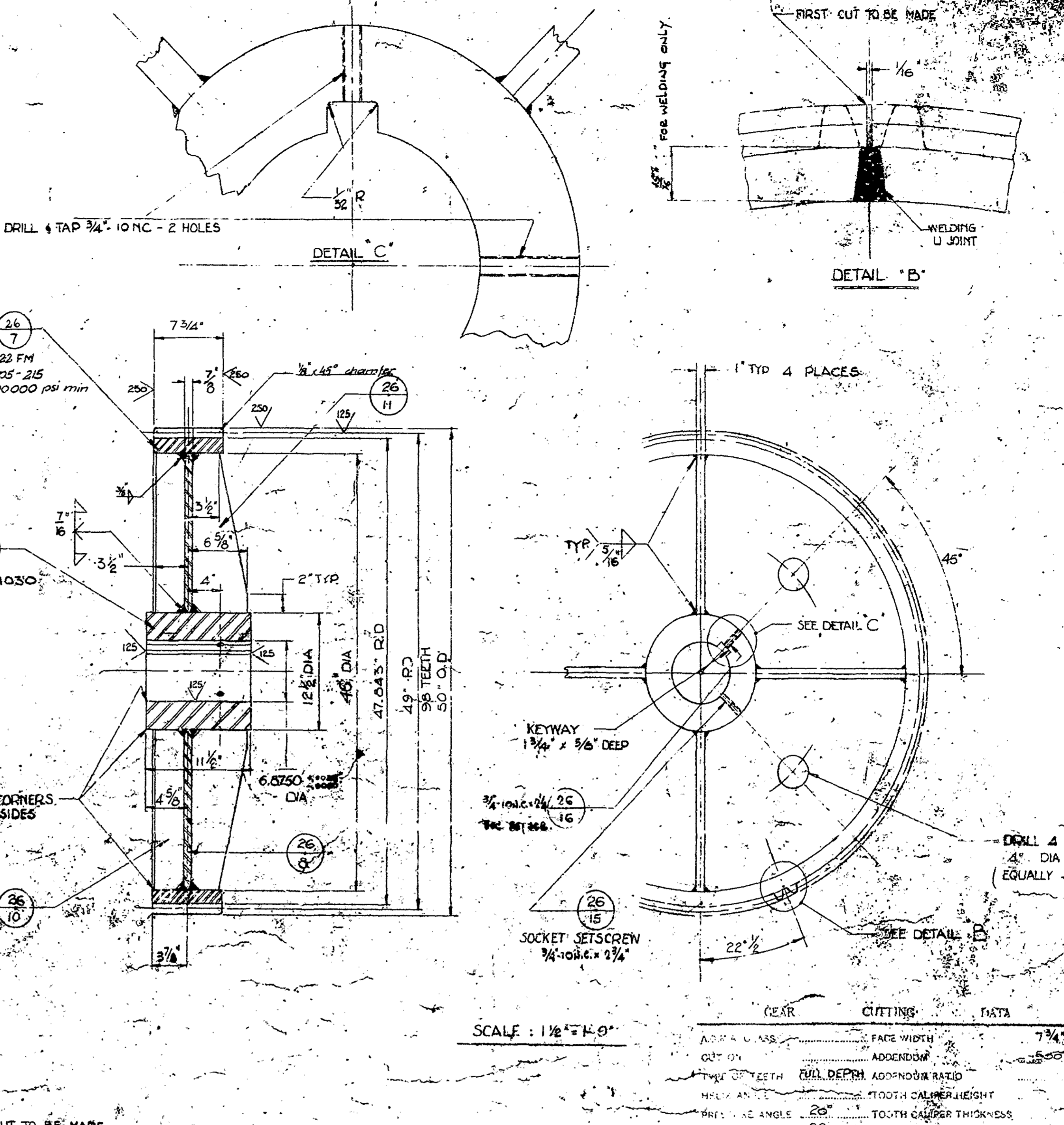

MAT. OF RIM: 222 FM  
 BHN of teeth: 205-215  
 UTS: 100000 psi min

SCALE: 1 1/2" = 1'-0"

GEAR	CUTTING	DATA
ADD. CLASS	FACE WIDTH	7 3/4"
CUT ON	ADDENDUM	1.500
TYPE OF TEETH	FULL DEPTH	ADDENDUM RATIO
HELIX ANGLE	TOOTH CALIPER HEIGHT	
PRESSURE ANGLE	TOOTH CALIPER THICKNESS	
NO. OF TEETH	BACKLASH TOTAL	.014-.020
PITCH	TOOTH MATING GEAR	20
PITCH DIA.	CENTRE DISTANCE	49.000
OUTSIDE DIA.	OR NON STANDARD RATIO	50.000
ROOT DIA.	SHAFTS PARALLEL OR NOT	PARALLEL

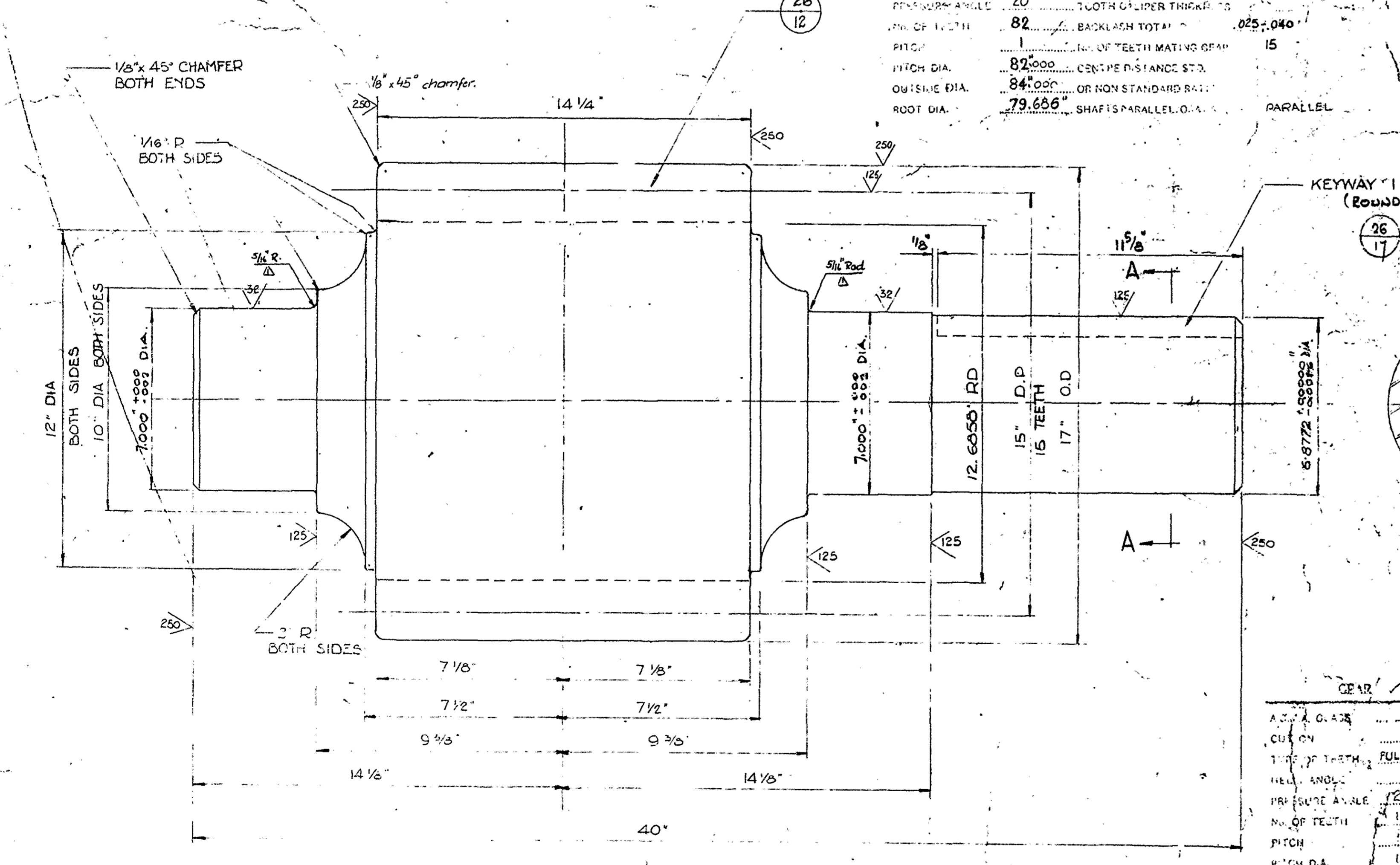

ULTIMO 4  
 HARDENED 250 TO 260 BHN  
 UTS 125000 PSI APPROX.  
 SCALE: 4" = 1'-0"

GEAR	CUTTING	DATA
ADD. CLASS	FACE WIDTH	14 1/2"
CUT ON	ADDENDUM	1.000
TYPE OF TEETH	FULL DEPTH	ADDENDUM RATIO
HELIX ANGLE	TOOTH CALIPER HEIGHT	
PRESSURE ANGLE	TOOTH CALIPER THICKNESS	
NO. OF TEETH	BACKLASH TOTAL	.025-.040
PITCH	TOOTH MATING GEAR	15
PITCH DIA.	CENTRE DISTANCE	70.000
OUTSIDE DIA.	OR NON STANDARD RATIO	76.000
ROOT DIA.	SHAFTS PARALLEL OR NOT	PARALLEL

SCALE: HALF SIZE

GEAR	CUTTING	DATA
ADD. CLASS	FACE WIDTH	7 3/4"
CUT ON	ADDENDUM	1.500
TYPE OF TEETH	FULL DEPTH	ADDENDUM RATIO
HELIX ANGLE	TOOTH CALIPER HEIGHT	
PRESSURE ANGLE	TOOTH CALIPER THICKNESS	
NO. OF TEETH	BACKLASH TOTAL	.014-.020
PITCH	TOOTH MATING GEAR	20
PITCH DIA.	CENTRE DISTANCE	49.000
OUTSIDE DIA.	OR NON STANDARD RATIO	50.000
ROOT DIA.	SHAFTS PARALLEL OR NOT	PARALLEL

**STRESS RELIEVE BEFORE MACHINING**

**WELDING**

ALL WELDING TO BE DONE BY QUALIFIED WELDERS ONLY IN ACCORDANCE WITH U.S.A. STANDARDS W-47 W-78 W-58 (LATEST EDITIONS)

FOR PAINTING INSTRUCTIONS AND SURFACE PROTECTION SEE DWG. 0-21-101-13

RECEIVED  
 APR 29 1964

DESIGNED	DRAWN	CHECKED	SUBMITTED	APPROVED
J.R.	J.R.	J.R.	J.R.	J.R.

**CANADIAN VICKERS LIMITED**  
 MONTREAL, CANADA  
 INDUSTRIAL DIVISION  
 QUEBEC HYDRO-ÉLECTRIQUE  
 CURIEUR DEVELOPPEMENT TRANSPORT  
 VERIFICATION

**- NOTE -**  
 The legibility of this drawing is substandard and may result in poor microfilm reproduction.







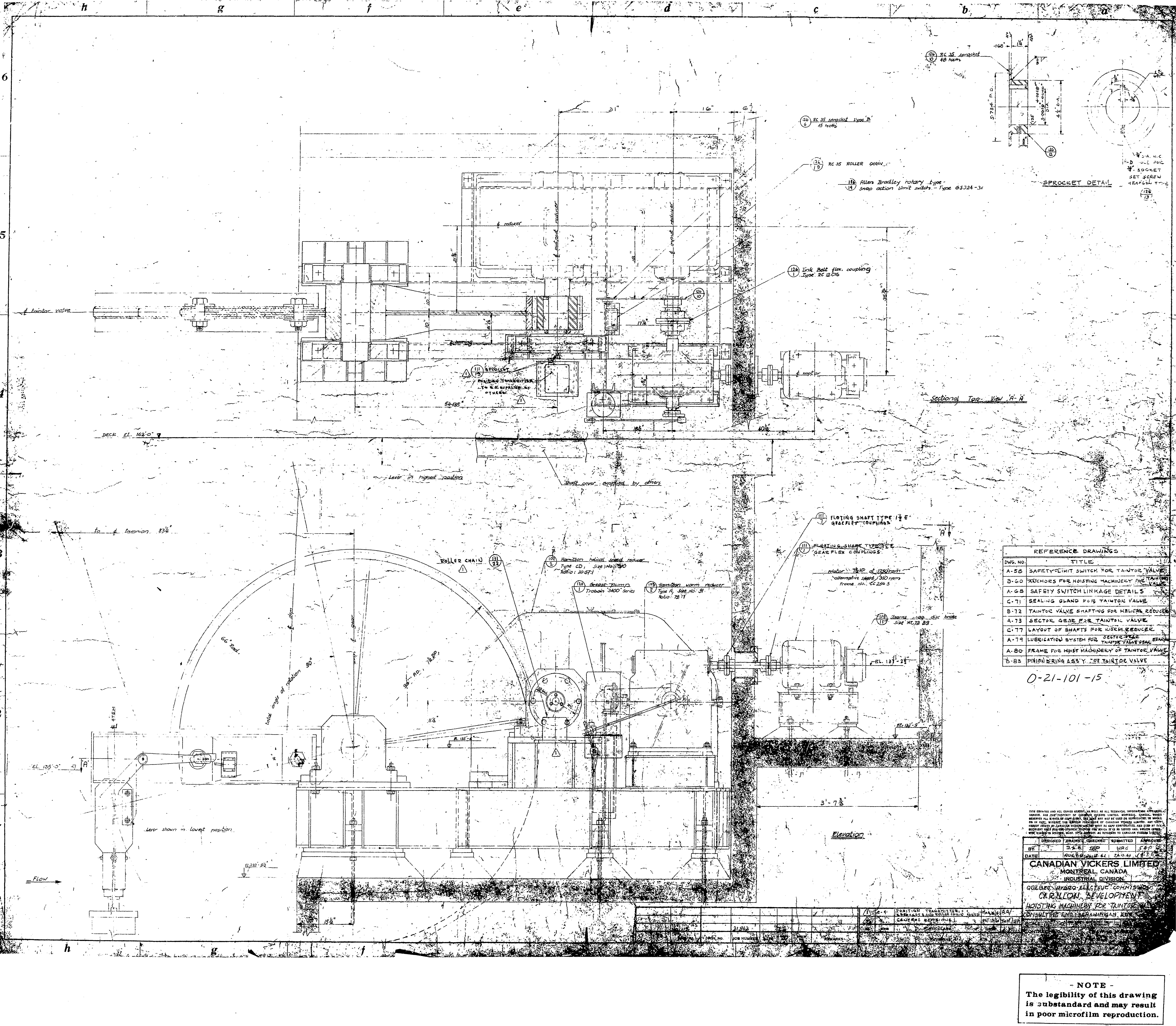

SPROCKET DETAIL

Sectional Top View A-A

Elevation

REFERENCE DRAWINGS	
DWG. NO.	TITLE
A-58	SAFETY LIMIT SWITCH FOR TAINTOC VALVE
B-60	ANCHORS FOR HOISTING MACHINERY FOR TAINTOC VALVE
A-68	SAFETY SWITCH LINKAGE DETAILS
C-71	SEALING GLAND FOR TAINTOC VALVE
B-72	TAINTOC VALVE SHAFTING FOR HELICAL REDUCER
A-73	SECTOR GEAR FOR TAINTOC VALVE
C-77	LAYOUT OF SHAFTS FOR WORM REDUCER
A-79	LUBRICATION SYSTEM FOR SECTOR GEAR BEARING
A-80	FRAME FOR HOIST MACHINERY OF TAINTOC VALVE
B-83	PINION BRG ASSY. OF TAINTOC VALVE

O-21-101-15

THIS DRAWING AND ALL OTHERS HEREON, AS WELL AS ALL TECHNICAL INFORMATION APPROPRIATE THEREON, ARE THE PROPERTY OF CANADIAN VICKERS LIMITED, MONTRÉAL, CANADA, WHICH RESERVES ALL RIGHTS OF COPYRIGHT. THIS DRAWING MAY NOT BE USED OR REPRODUCED IN WHOLE OR IN PART, WITHOUT THE WRITTEN PERMISSION OF CANADIAN VICKERS LIMITED. ANY COPY HEREBY MADE BY CANADIAN WORKERS OR EMPLOYEES OF CANADIAN VICKERS LIMITED IS STRICTLY CONFIDENTIAL AND IS TO BE KEPT CONFIDENTIAL AND USED ONLY FOR THE PURPOSES FOR WHICH IT WAS ISSUED AND NOT BE LOANED, REPRODUCED, COPIED, REPRODUCED, OR IN ANY MANNER DISCLOSED TO ANY OTHER PERSON OR ORGANIZATION. ALL RIGHTS ARE RESERVED TO CANADIAN VICKERS LIMITED.

DESIGNED	DRAWN	CHECKED	SUBMITTED	APPROVED
BY: J.S.B. JRP	WRC	S.P.P.		
DATE: AUG 21 1961	24-10-61	18-5-61		

**CANADIAN VICKERS LIMITED**  
 MONTRÉAL, CANADA  
 INDUSTRIAL DIVISION

QUEBEC: HARVEY ELECTRIC CO. LTD.  
 CANADIAN DEVELOPMENT  
 HOISTING MACHINERY FOR TAINTOC VALVE  
 CONSULTING ENG. SARAHMUNGAN, INC.

- NOTE -  
 The legibility of this drawing is substandard and may result in poor microfilm reproduction.



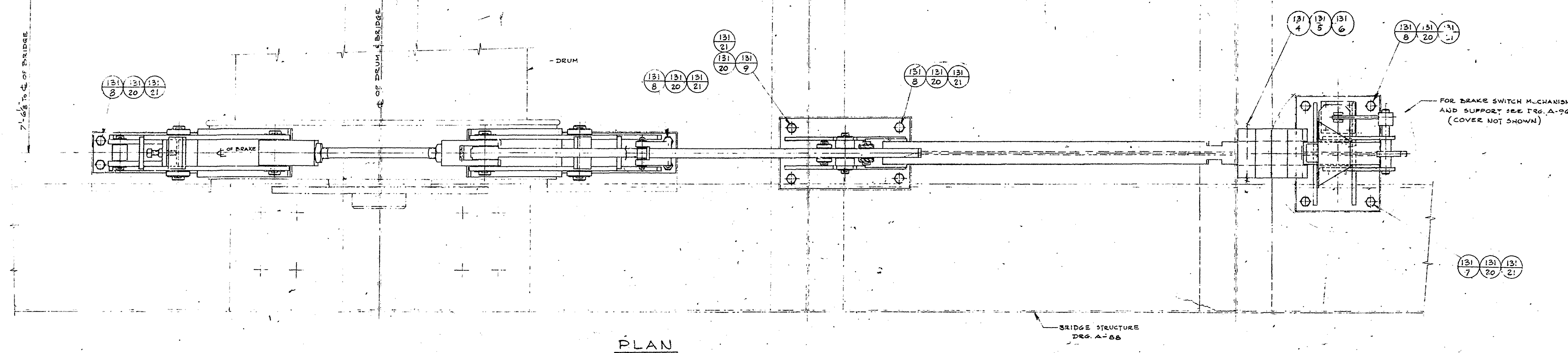

PLAN

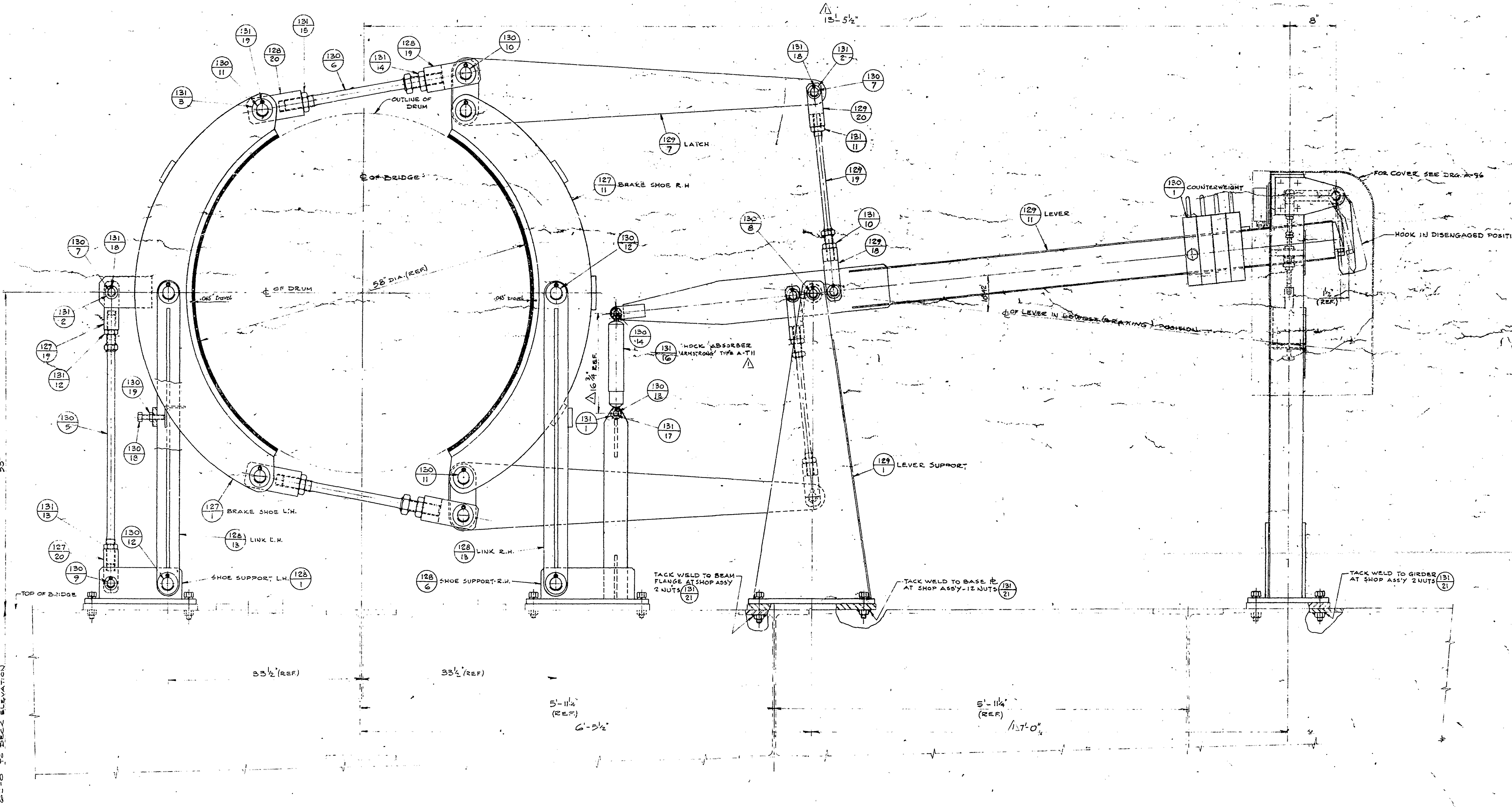

ELEVATION

0-21-101-16  
 Rated capacity of brake: 85,000 ft lbs  
 Brake drum dia: 58"  
 Travel per brake shoe: .045"  
 to be adjusted at assembly.

HYDRO-QUEBEC  
 DIVISION OF INDUSTRIAL DEVELOPMENT  
 MONTREAL, CANADA  
 APR 29 1964  
 RECEIVED  
 SECTION ADMINISTRATION

THIS DRAWING AND ALL COPIES HEREOF, AS WELL AS ALL FEDERAL INFORMATION APPEARING HEREON, ARE THE PROPERTY OF CANADIAN VICKERS LIMITED, MONTREAL, CANADA, WHICH RESERVES ALL RIGHTS OF COPYRIGHT. THE SAME ARE NOT TO BE LOANED OR REPRODUCED IN WHOLE OR IN PART, WITHOUT THE WRITTEN PERMISSION OF CANADIAN VICKERS LIMITED. ANY COPY HEREOF ISSUED BY CANADIAN VICKERS LIMITED MUST BE KEPT CONFIDENTIAL AND USED BY THE RECIPIENT ONLY FOR THE SPECIFIC PURPOSE FOR WHICH IT IS ISSUED AND, UNLESS OTHERWISE AGREED IN WRITING, MUST, UPON REQUEST, BE RETURNED TO CANADIAN VICKERS LIMITED.

DESIGN NO.	TITLE	ISS.	REV.	DATE	BY	CHKD.	APP'D.	REMARKS
A-76	BRAKE SWITCH MECHANISM ASSY & DETAILS							
A-87	EMERGENCY BRAKE DETAILS							
A-88	SUPERSTRUCTURE BRIDGE							
A-17	DRUM ASSY							
A-14	HOIST MACHINERY FOR VERTICAL LIFT GATE							

DESIGNED	DRAWN	CHECKED	SUBMITTED	APPROVED
BY: G.J.E.D.	AS	NRG	NRG	NRG
DATE: 19 Dec 61	19 Dec 61	20 Dec 61	21 Dec 61	21 Dec 61

CANADIAN VICKERS LIMITED  
 MONTREAL, CANADA  
 INDUSTRIAL DIVISION  
 QUEBEC - HYDRO ELECTRIC COMMISSION  
 CABILLON DEVELOPMENT - NAVIGATION LOCK - 8800 FT  
 EMERGENCY BRAKE ASSY  
 FOR VERTICAL LIFT GATE  
 CONSULTING ENG: SHAWINIGAN ENGINEERING CO. LTD.  
 SCALE: 1/2" = 1'-0"  
 CONTRACT NO. 21962  
 DRAWING NUMBER A-88

- NOTE -  
 The legibility of this drawing is substandard and may result in poor microfilm reproduction.



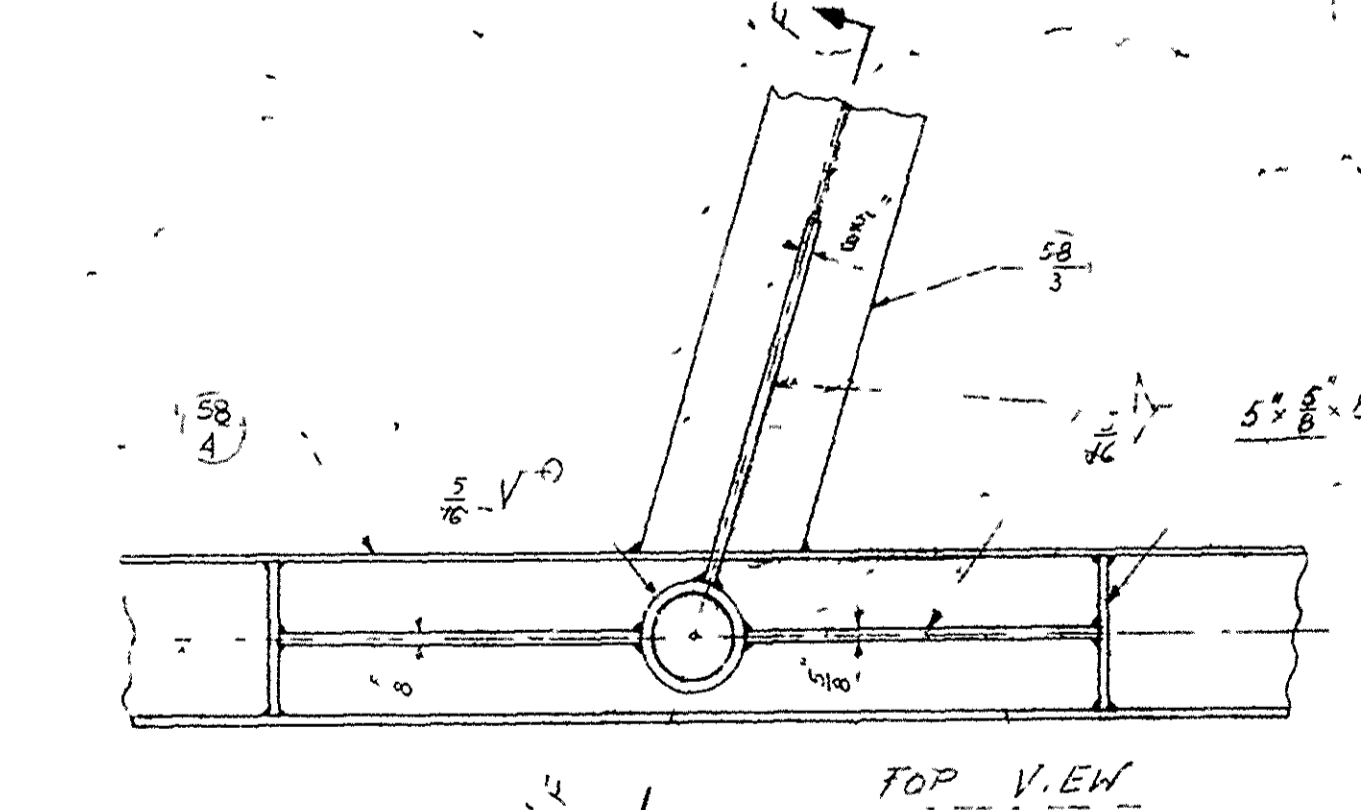
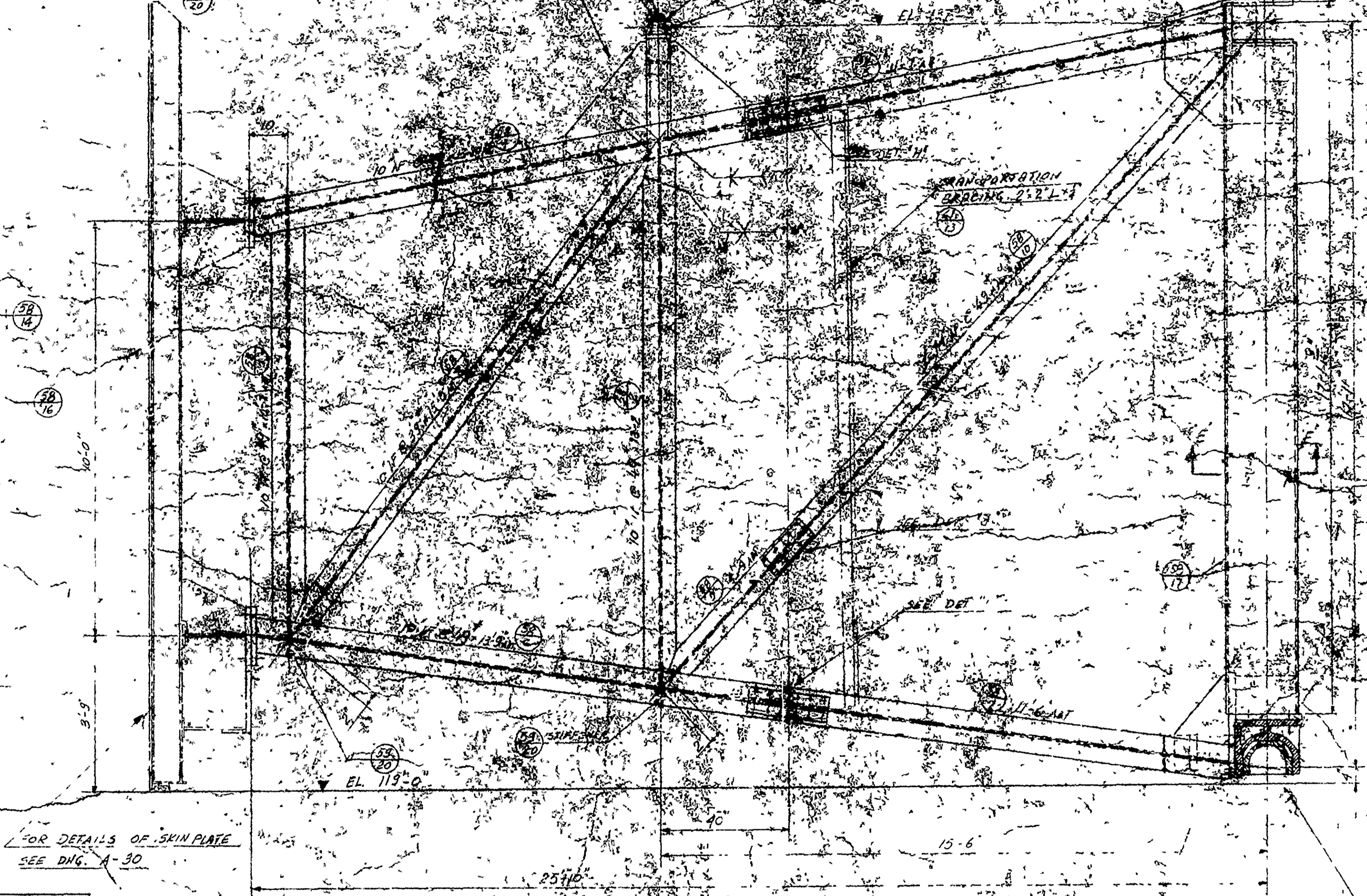
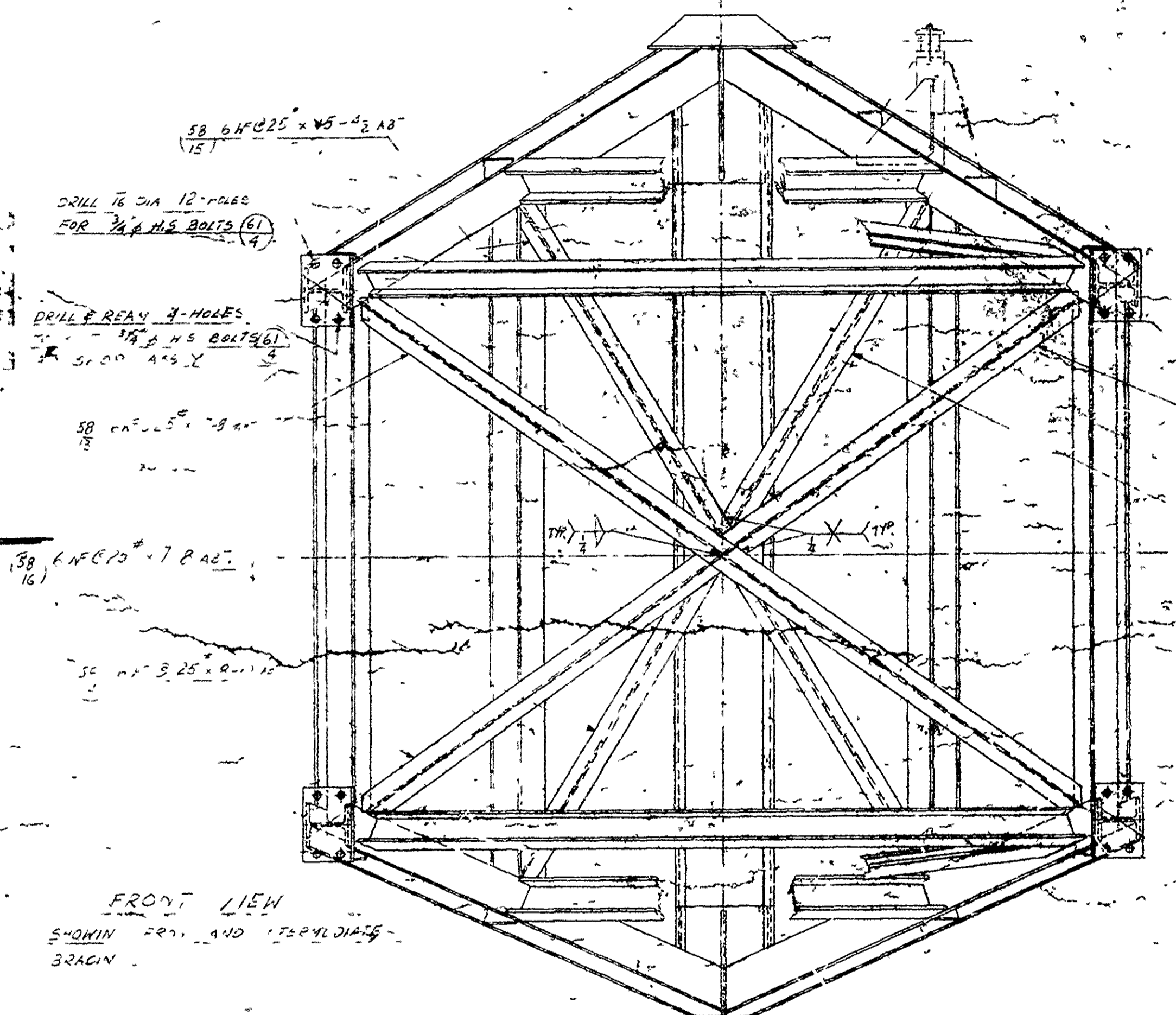
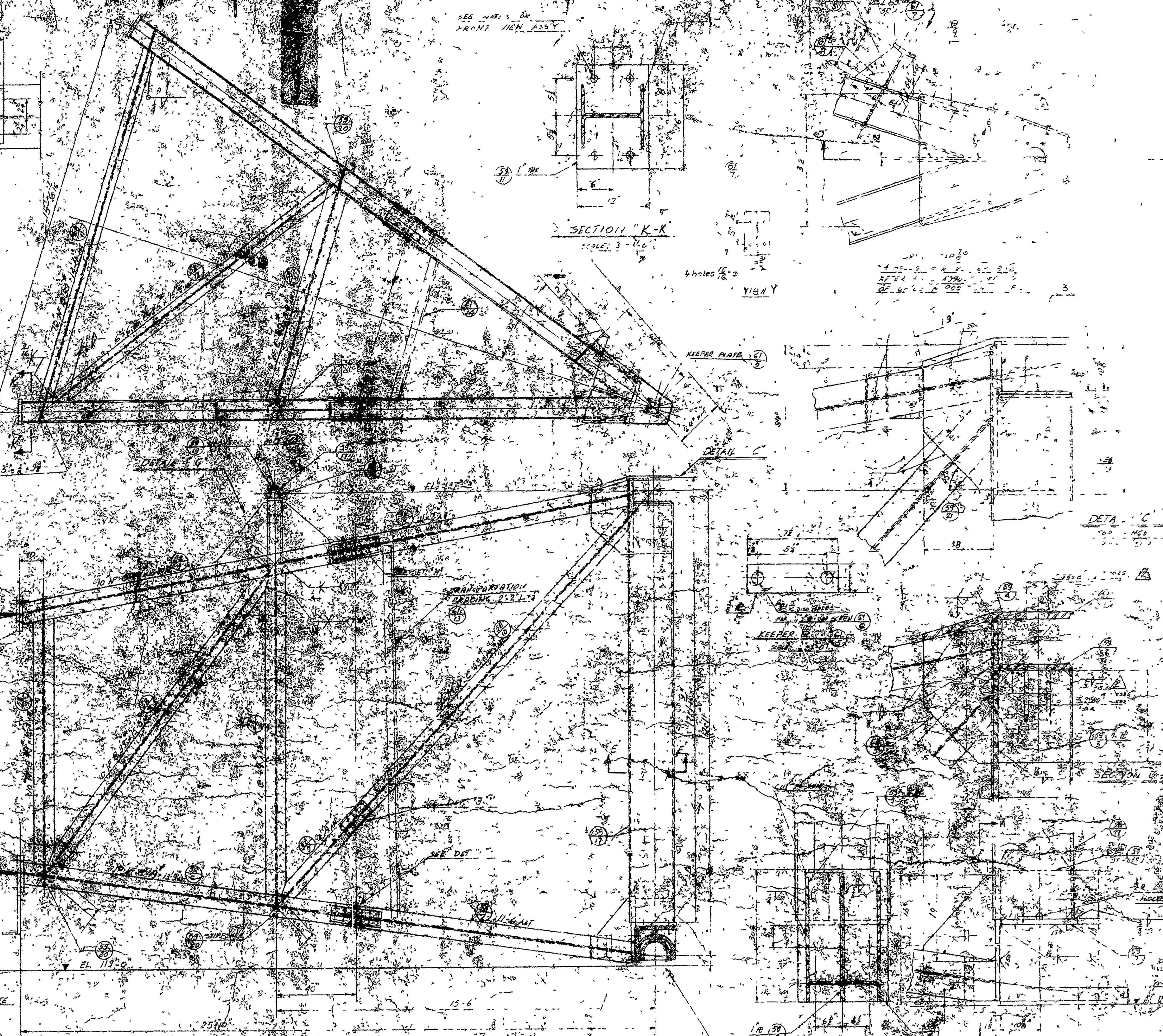
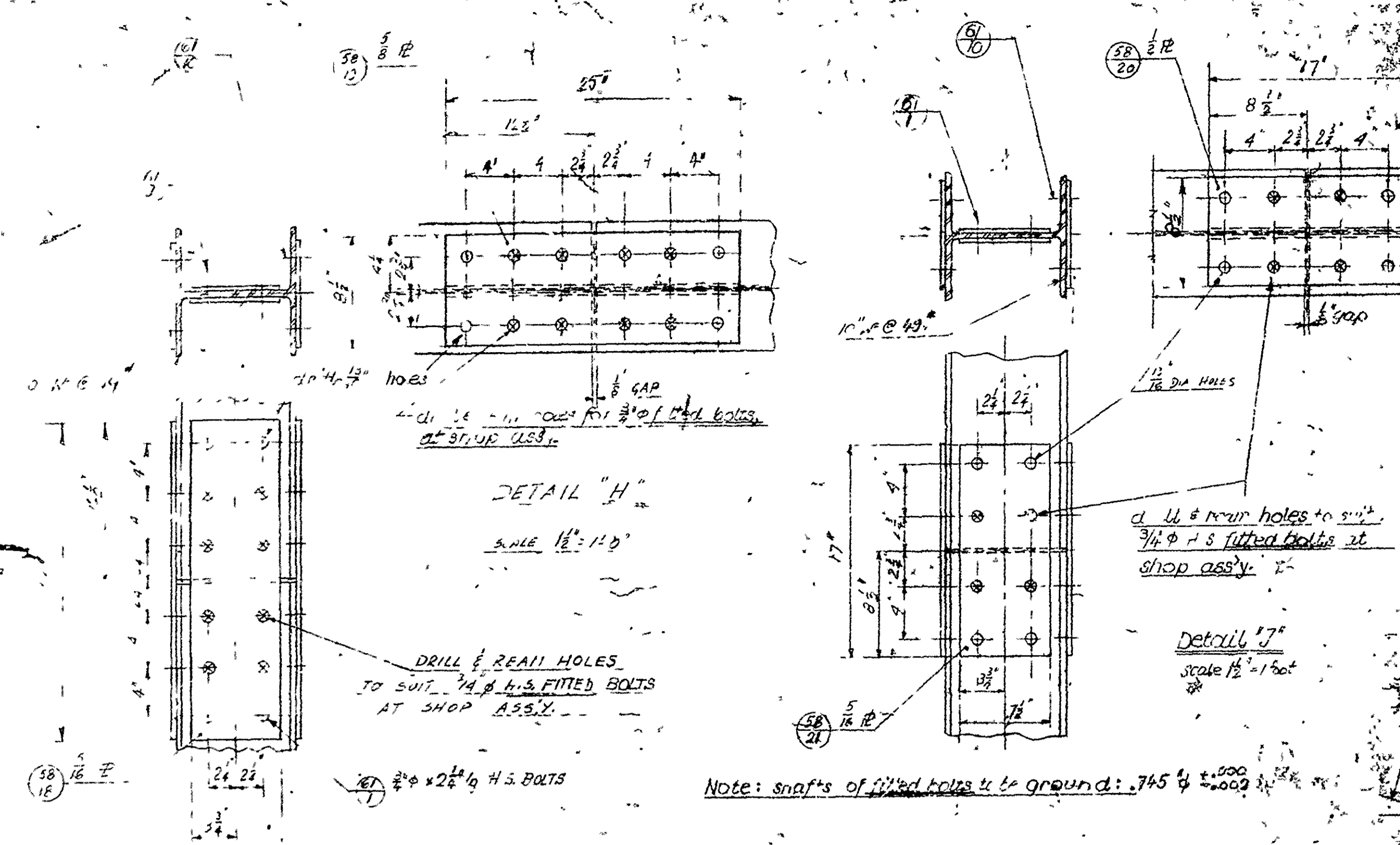

FRAMES ONE AS SHOWN R.H. AND ONE OPPOSITE L.H.

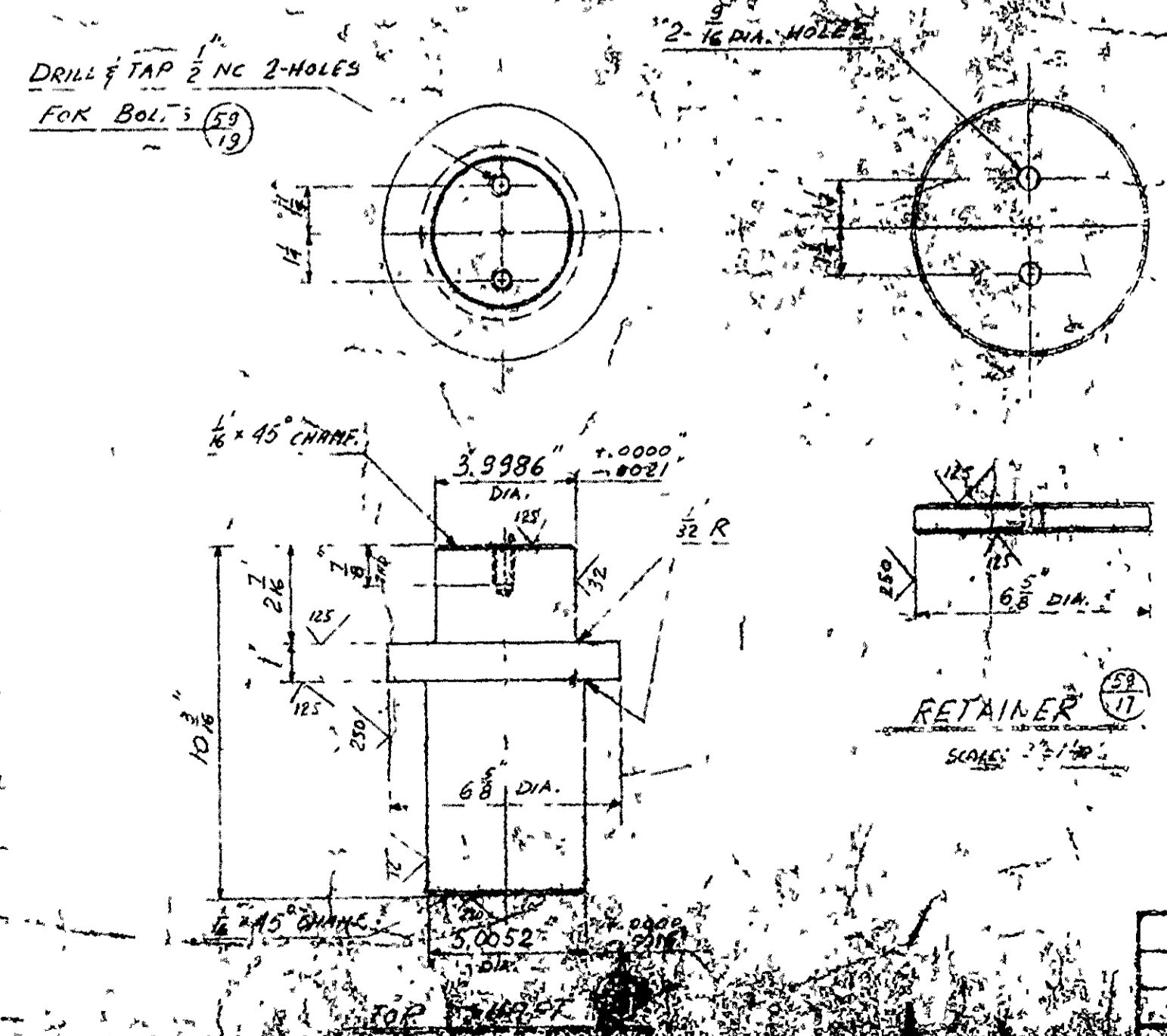

**WELDING**  
ALL WELDING TO BE DONE BY QUALIFIED WELDERS ONLY IN ACCORDANCE WITH C.B.A. STANDARDS W-47 W-48 W-49 (LATEST EDITIONS)

PRINTING INSTRUCTION SEE DNG. C-2

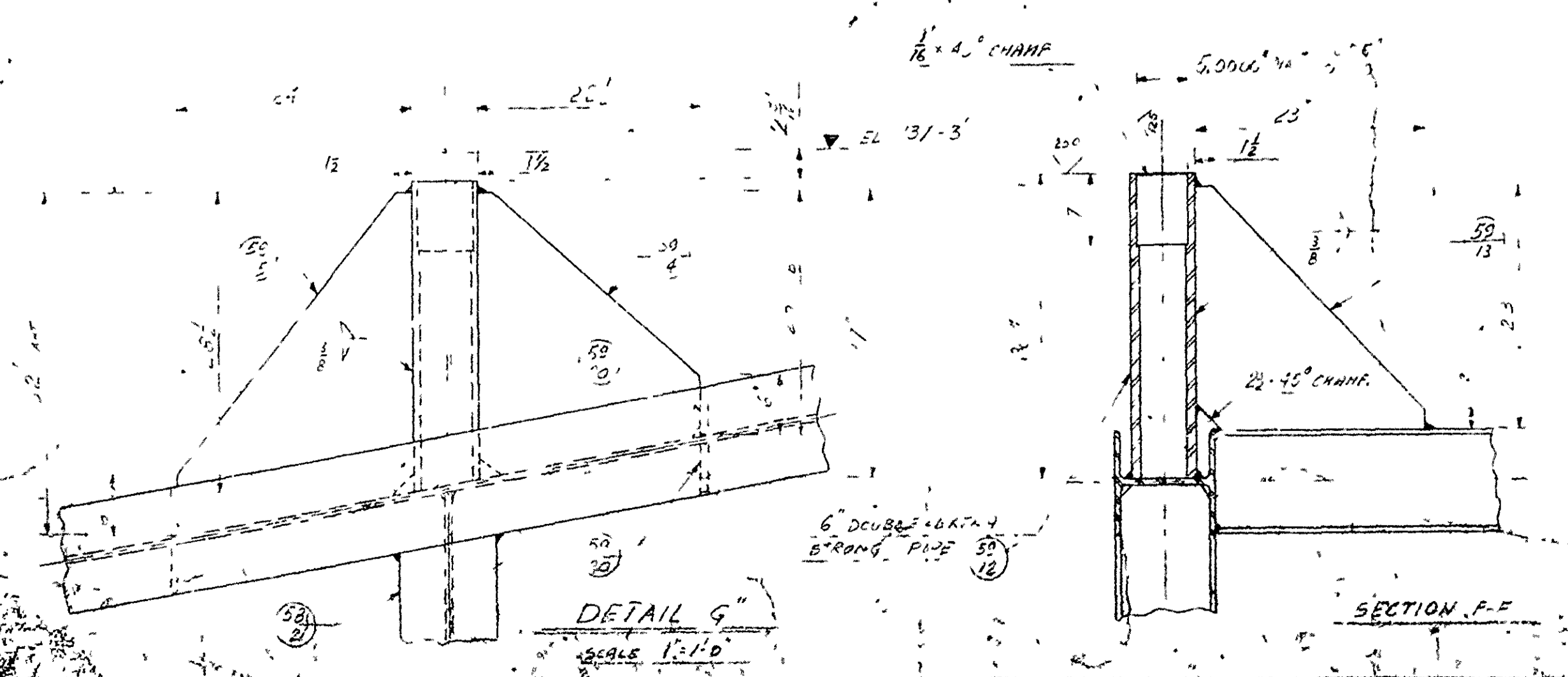

REFERENCE DRAWINGS

SECTION A-A	1/2" = 1'-0"
SECTION B-B	1/2" = 1'-0"
SECTION C-C	1/2" = 1'-0"
SECTION D-D	1/2" = 1'-0"
SECTION E-E	1/2" = 1'-0"
SECTION F-F	1/2" = 1'-0"
SECTION G-G	1/2" = 1'-0"
SECTION H-H	1/2" = 1'-0"
SECTION I-I	1/2" = 1'-0"
SECTION J-J	1/2" = 1'-0"
SECTION K-K	3/4" = 1'-0"
SECTION L-L	1/2" = 1'-0"
SECTION M-M	1/2" = 1'-0"
SECTION N-N	1/2" = 1'-0"
SECTION O-O	1/2" = 1'-0"
SECTION P-P	1/2" = 1'-0"
SECTION Q-Q	1/2" = 1'-0"
SECTION R-R	1/2" = 1'-0"
SECTION S-S	1/2" = 1'-0"
SECTION T-T	1/2" = 1'-0"
SECTION U-U	1/2" = 1'-0"
SECTION V-V	1/2" = 1'-0"
SECTION W-W	1/2" = 1'-0"
SECTION X-X	1/2" = 1'-0"
SECTION Y-Y	1/2" = 1'-0"
SECTION Z-Z	1/2" = 1'-0"

DATE: 1/2/57

APPROVED: [Signature]

MONTEAL VICKERS LIMITED  
MONTEAL, CANADA  
INDUSTRIAL DIVISION

NO.	DATE	BY	CHKD.	APP'D.	REVISION
1	1/2/57	[Signature]	[Signature]	[Signature]	ISSUED FOR CONSTRUCTION
2	1/2/57	[Signature]	[Signature]	[Signature]	REVISION
3	1/2/57	[Signature]	[Signature]	[Signature]	REVISION
4	1/2/57	[Signature]	[Signature]	[Signature]	REVISION
5	1/2/57	[Signature]	[Signature]	[Signature]	REVISION
6	1/2/57	[Signature]	[Signature]	[Signature]	REVISION
7	1/2/57	[Signature]	[Signature]	[Signature]	REVISION
8	1/2/57	[Signature]	[Signature]	[Signature]	REVISION
9	1/2/57	[Signature]	[Signature]	[Signature]	REVISION
10	1/2/57	[Signature]	[Signature]	[Signature]	REVISION

The integrity of this drawing is subordinate and may result in poor construction.



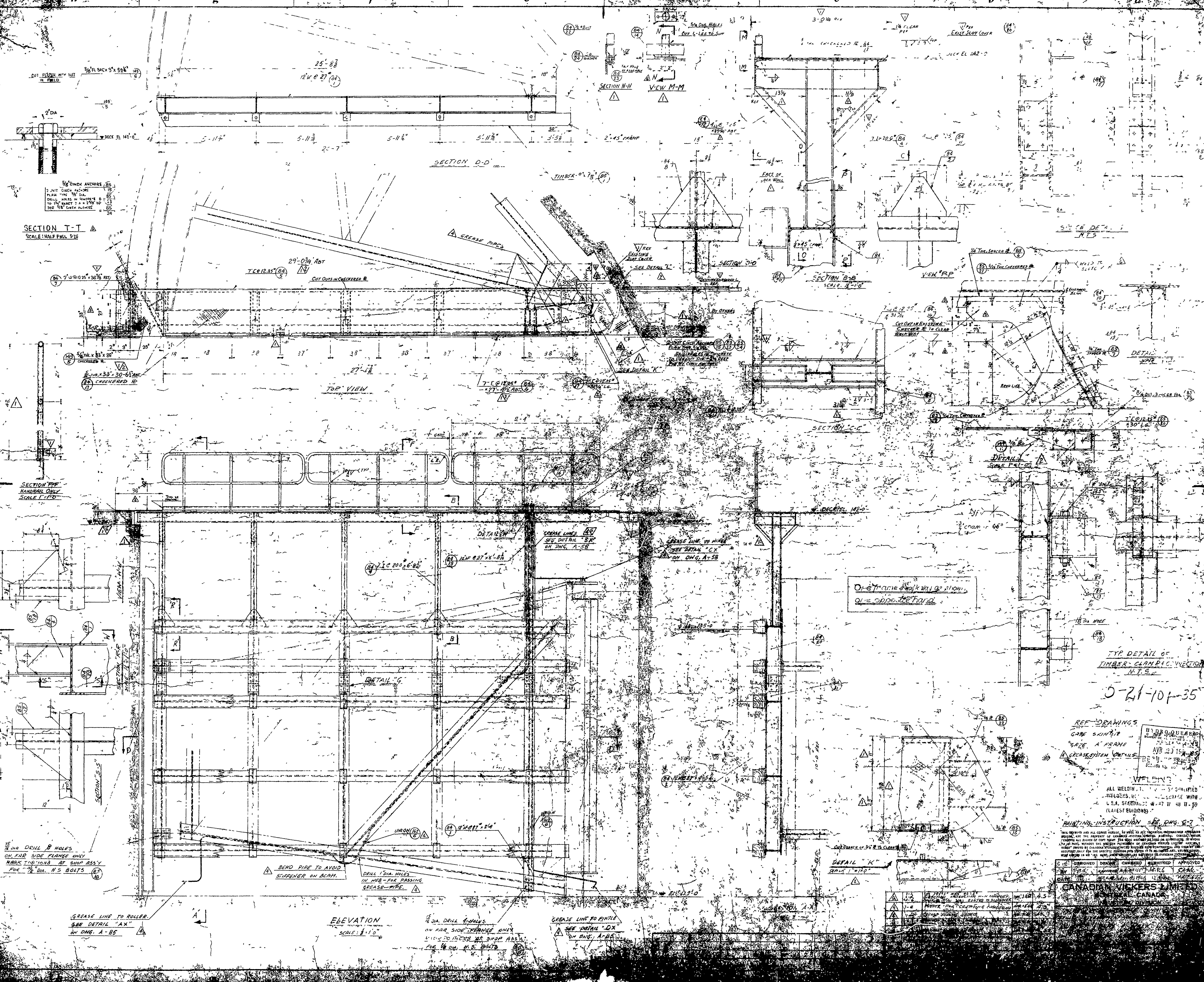

SECTION T-T  
SCALE: HALF FULL SIZE

SECTION P-P  
HANDRAIL ONLY  
SCALE 1"=1'-0"

IF FROM DRILL B HOLES  
ON FAR SIDE FLANGE ONLY  
MARK TYPICALS AT SHOP ASSY  
FOR 1/2" DIA. H.S. BOLTS

GREASE LINE TO ROLLER  
SEE DETAIL "AX"  
ON DWG. A-B5

GREASE LINE TO ROLLER  
SEE DETAIL "AX"  
ON DWG. A-B5

ELEVATION  
SCALE: 1/4"=1'-0"

1/2" DIA. DRILL B HOLES  
ON FAR SIDE FLANGE ONLY  
MARK TYPICALS AT SHOP ASSY  
FOR 1/2" DIA. H.S. BOLTS

GREASE LINE TO ROLLER  
SEE DETAIL "DX"  
ON DWG. A-B5

One frame & walk way as shown,  
one opposite hand.

TYP. DETAIL OF  
TIMBER CLAMP CONNECTION  
N.T.S.

0-21-101-35

REF. DRAWINGS  
CORE SHEET  
"A" FRAME  
GREASE SYSTEM DETAILS

WELDER  
ALL WELDS TO BE CHALLENGED  
WELDER'S SIGNATURE AND LICENSE NO.  
U.S.A. STANDARD W-47 W 48 W 50  
(LATEST EDITIONS)

PAINTING INSTRUCTION SEE DWG. S-7

THIS DRAWING AND ALL CONTENTS THEREIN ARE THE PROPERTY OF CANADIAN OVERSEAS INVESTMENT CORPORATION. NO PARTS OF THIS DRAWING ARE TO BE REPRODUCED OR TRANSMITTED IN ANY FORM OR BY ANY MEANS, ELECTRONIC OR MECHANICAL, INCLUDING PHOTOCOPYING, RECORDING, OR BY ANY INFORMATION STORAGE AND RETRIEVAL SYSTEM, WITHOUT THE WRITTEN PERMISSION OF CANADIAN OVERSEAS INVESTMENT CORPORATION. ANY REPRODUCTION OR TRANSMISSION OF THIS DRAWING WITHOUT THE WRITTEN PERMISSION OF CANADIAN OVERSEAS INVESTMENT CORPORATION IS PROHIBITED.

DESIGNED	DRAWN	CHECKED	SUBMITTED	APPROVED

CANADIAN OVERSEAS INVESTMENT CORPORATION  
CANADIAN OVERSEAS INVESTMENT CORPORATION  
CANADIAN OVERSEAS INVESTMENT CORPORATION

1/2" DIA. DRILL B HOLES  
ON FAR SIDE FLANGE ONLY  
MARK TYPICALS AT SHOP ASSY  
FOR 1/2" DIA. H.S. BOLTS

GREASE LINE TO ROLLER  
SEE DETAIL "DX"  
ON DWG. A-B5

GREASE LINE TO ROLLER  
SEE DETAIL "DX"  
ON DWG. A-B5

GREASE LINE TO ROLLER  
SEE DETAIL "DX"  
ON DWG. A-B5

GREASE LINE TO ROLLER  
SEE DETAIL "DX"  
ON DWG. A-B5

GREASE LINE TO ROLLER  
SEE DETAIL "DX"  
ON DWG. A-B5

GREASE LINE TO ROLLER  
SEE DETAIL "DX"  
ON DWG. A-B5

- NOTE -  
The legibility of this drawing is substandard and may result in poor microfilm reproduction.



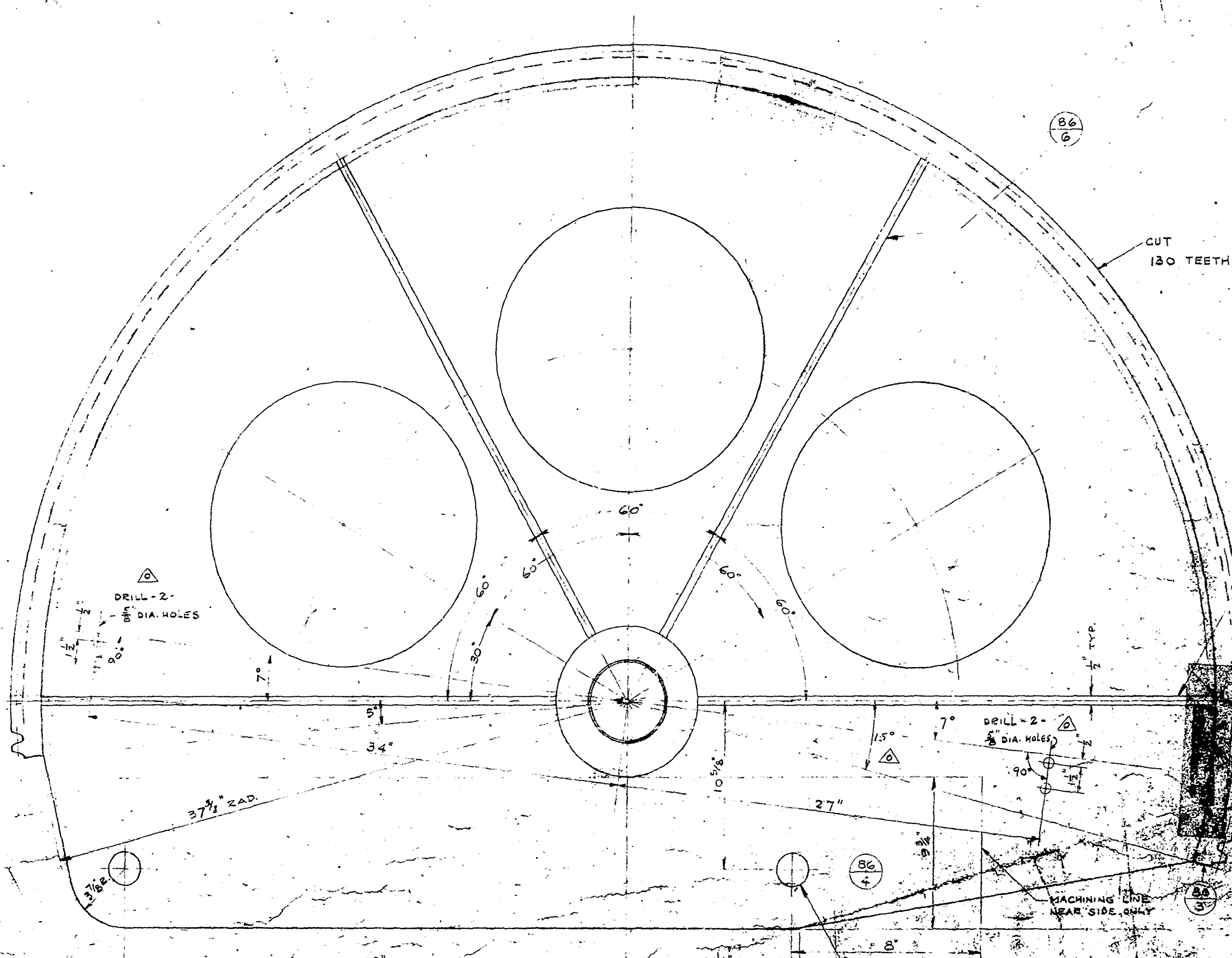

**SECTOR GEAR**  
 MATL: 222 FM STEEL  
 UTS: 100,000  
 BHN: 195-210

CUTTING DATA	
ADD. CLASS	ST. INCL. TO AG. WIDTH
CUT ON	ADDENDUM
TYPE OF TOOTH	ADDENDUM RATIO
TOOTH ANGLE	TOOTH CALIPER HEIGHT
TOOTH ANGLE	TOOTH CALIPER THICKNESS
NO. OF TEETH	TOOTH CALIPER THICKNESS
NO. OF TEETH	NO. OF TEETH MACHINING
NO. OF TEETH	CENTRE DISTANCE
NO. OF TEETH	NO. OF TEETH MACHINING
NO. OF TEETH	NO. OF TEETH MACHINING

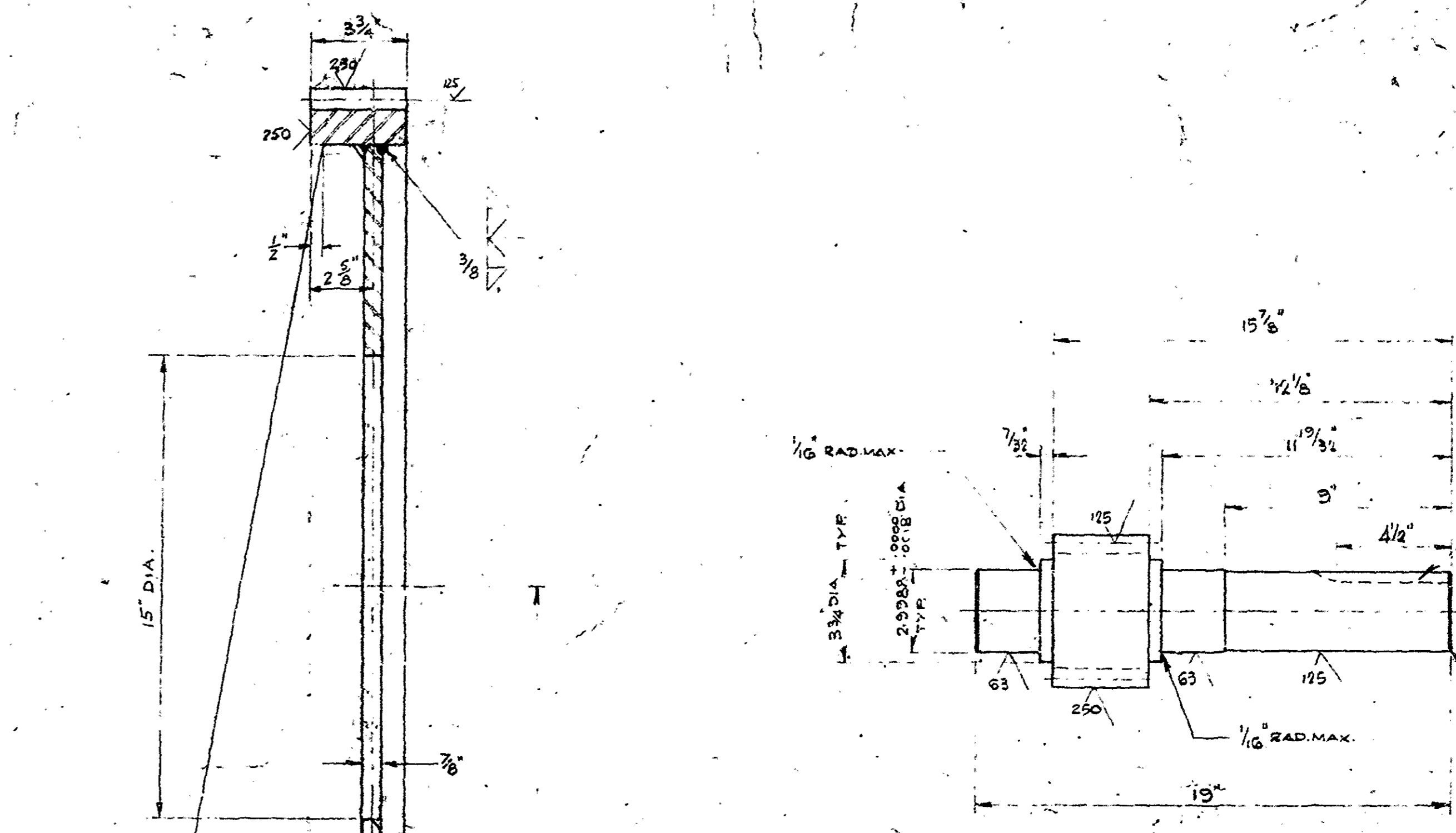

**PINION** 2-REQ'D.  
 MATL: ATLAS SPS 245 HEAT TREATED TO:  
 UTS: 120,000 PSI  
 YIELD POINT: 95,000  
 BRINELL HARDNESS NO.: 265-275

CUTTING DATA	
ADD. CLASS	ST. INCL. TO AG. WIDTH
CUT ON	ADDENDUM
TYPE OF TOOTH	ADDENDUM RATIO
TOOTH ANGLE	TOOTH CALIPER HEIGHT
TOOTH ANGLE	TOOTH CALIPER THICKNESS
NO. OF TEETH	TOOTH CALIPER THICKNESS
NO. OF TEETH	NO. OF TEETH MACHINING
NO. OF TEETH	CENTRE DISTANCE
NO. OF TEETH	NO. OF TEETH MACHINING
NO. OF TEETH	NO. OF TEETH MACHINING

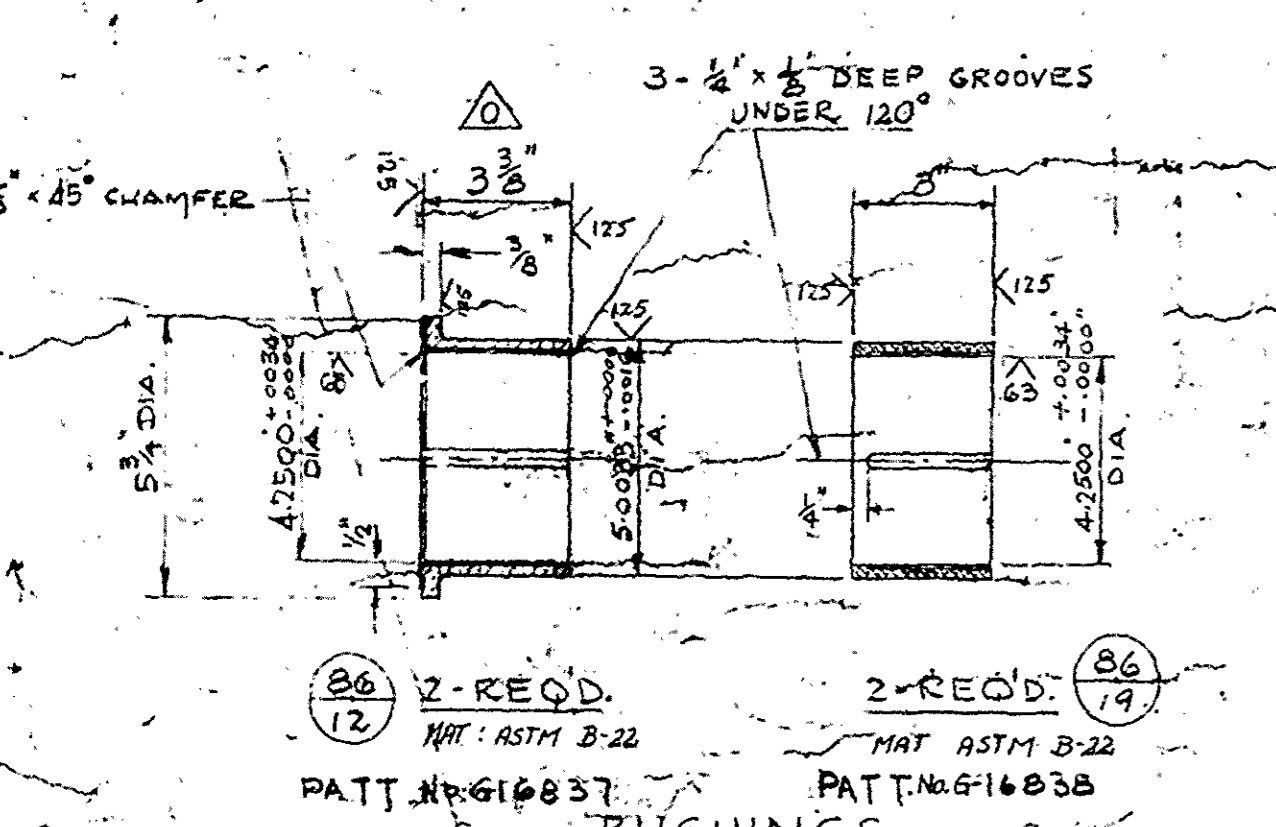

**BUSHING** 2-REQ'D.  
 MAT: ASTM B-22

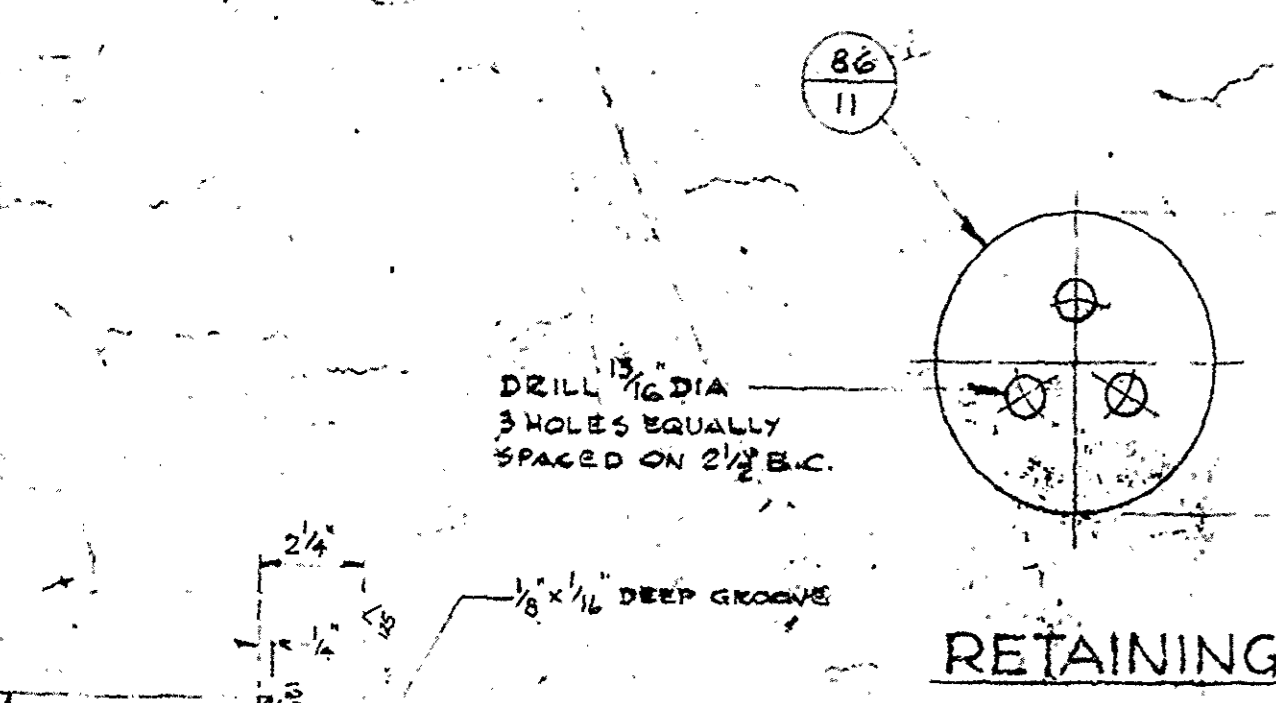

**RETAINING PLATE** 2-REQ'D.  
 MAT: ASTM B-22

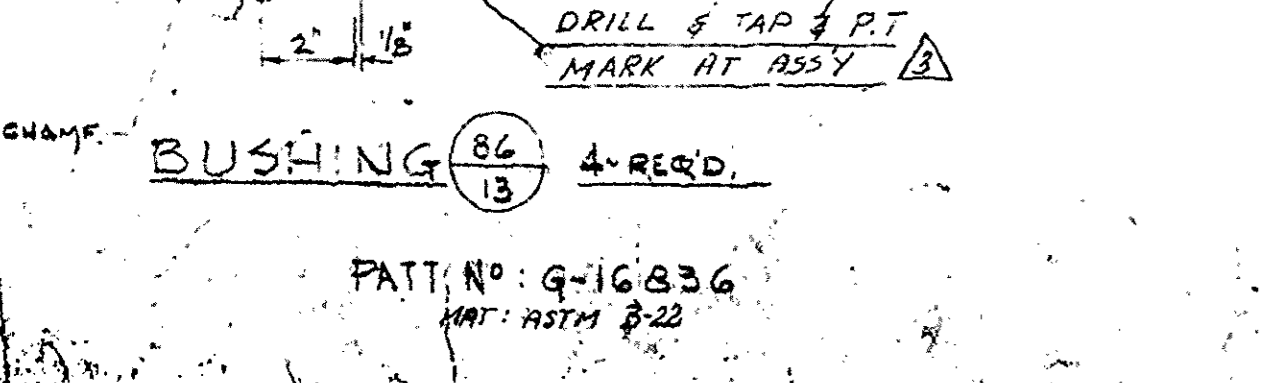

**BUSHING** 4-REQ'D.  
 MAT: ASTM B-22

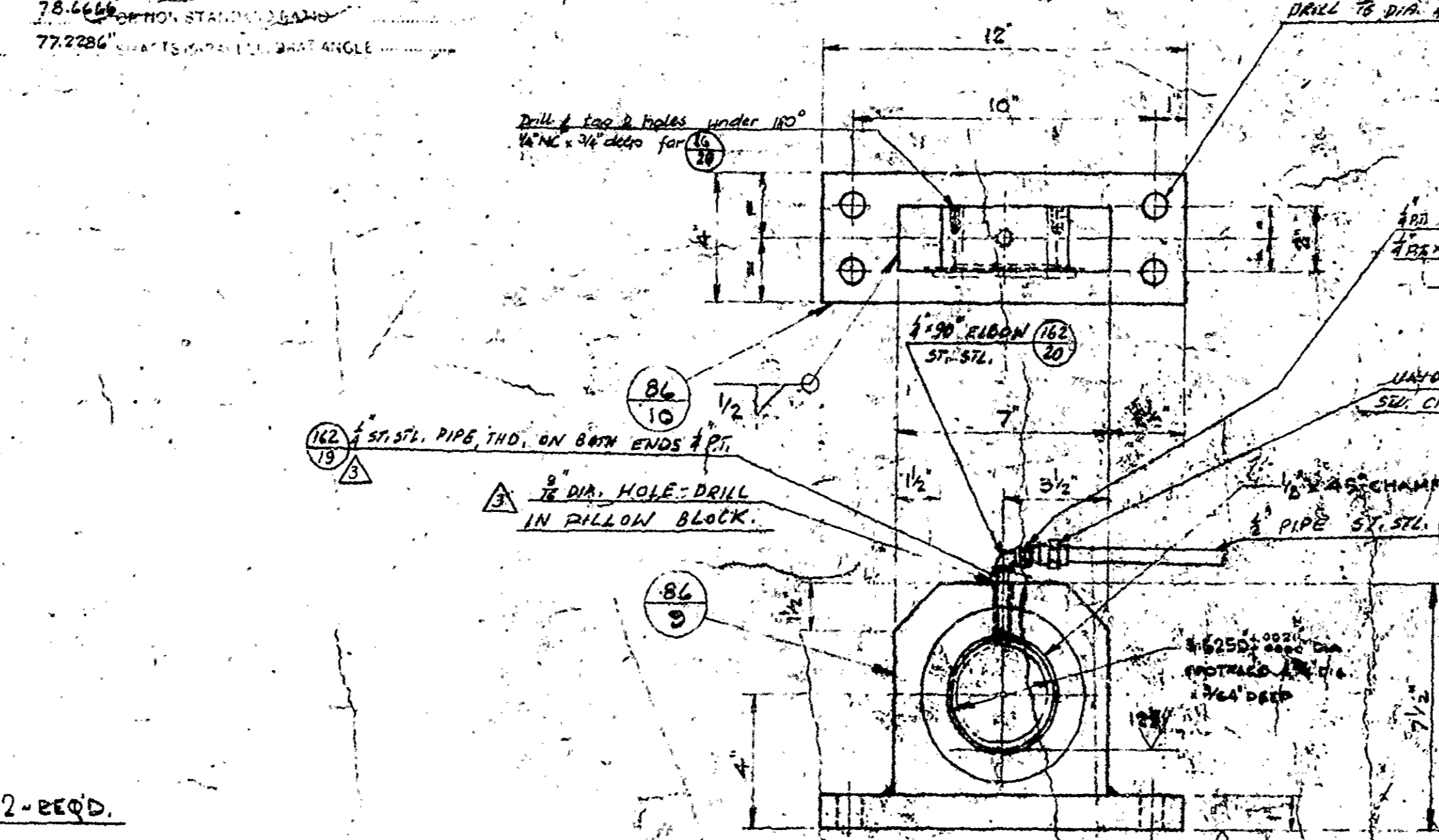

**BEARING BLOCK** 4-REQ'D.  
 MAT: SAE 3140 STEEL

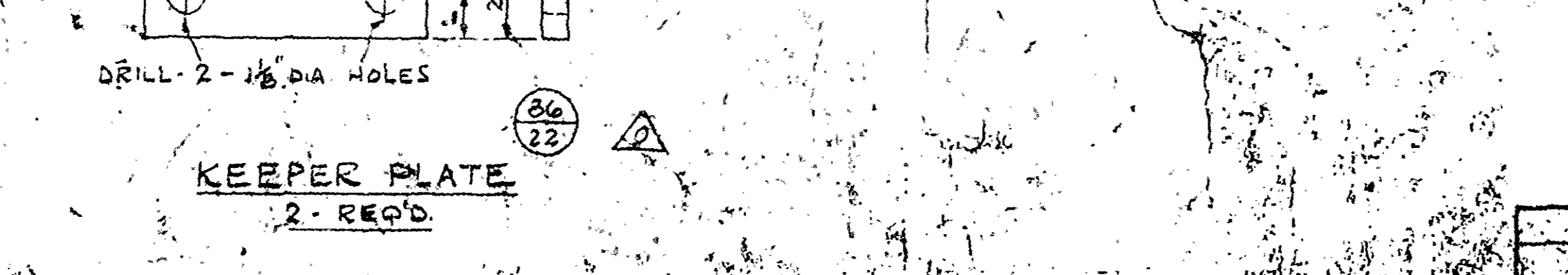

**KEEPER PLATE** 2-REQ'D.  
 MAT: ASTM B-22

- NOTES:**
1. STRESS RELIEVE WELDED PARTS BEFORE MACHINING.
  2. BREAK ALL SHARP CORNERS.
  3. FOR PAINTING INSTRUCTIONS SEE DWG C-7.

**WELDING**  
 ALL WELDING TO BE DONE BY QUALIFIED WELDERS ONLY IN ACCORDANCE WITH C.S.A. STANDARDS W-47 W-48 W-50 (LATEST EDITIONS)

REFERENCE DRAWINGS	
DWG. NO.	TITLE
A-87	SECTOR GATE MACHINERY ASSY.
C-65	SECTOR GATE GEAR ARM
A-66	SECTOR GATE STRUT
A-85	GREASE SYSTEM DETAILS

HYDRO QUALIFIED  
 CANADIAN VICKERS LIMITED  
 1000 AVENUE  
 MONTREAL, CANADA  
 AVR 29 1964

DESIGNED BY G. J. G. PEICE  
 DRAWN BY G. J. G. PEICE  
 CHECKED BY G. J. G. PEICE  
 DATE 24-9-61

**CANADIAN VICKERS LIMITED**  
 MONTREAL, CANADA  
 INDUSTRIAL DIVISION

QUEBEC HYDRO ELECTRIC COMMISSION  
 CARILLON DEVELOPMENT - NAVIGATION LOCK

**SECTOR GATE MACH**

**NOTE**  
 The legibility of this drawing is substandard and may result in poor microfilm reproduction.



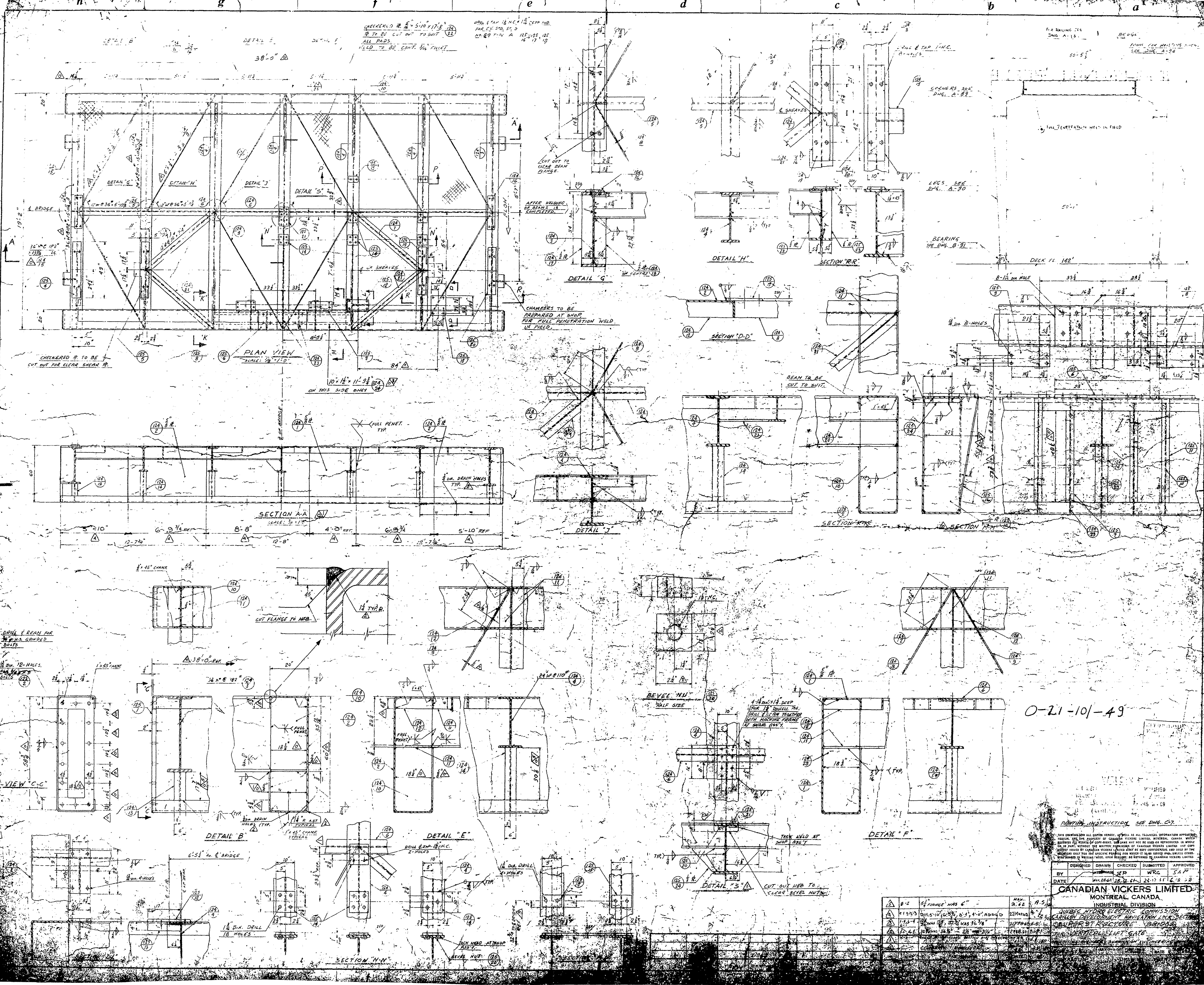

0-21-10-49

DESIGNED BY: WRC  
 DRAWN BY: JEP  
 CHECKED BY: WRC  
 SUBMITTED BY: WRC  
 APPROVED BY: S.P.  
 DATE: MAR 28 1949

**CANADIAN VICKERS LIMITED**  
 MONTREAL, CANADA  
 INDUSTRIAL DIVISION

NO.	DESCRIPTION	DATE	BY	CHKD.	APP'D.
1	AS SHOWN				
2	1/2" DIA. DRILL 10 HOLES				
3	1/2" DIA. DRILL 10 HOLES				
4	1/2" DIA. DRILL 10 HOLES				
5	1/2" DIA. DRILL 10 HOLES				
6	1/2" DIA. DRILL 10 HOLES				
7	1/2" DIA. DRILL 10 HOLES				
8	1/2" DIA. DRILL 10 HOLES				
9	1/2" DIA. DRILL 10 HOLES				
10	1/2" DIA. DRILL 10 HOLES				
11	1/2" DIA. DRILL 10 HOLES				
12	1/2" DIA. DRILL 10 HOLES				
13	1/2" DIA. DRILL 10 HOLES				
14	1/2" DIA. DRILL 10 HOLES				
15	1/2" DIA. DRILL 10 HOLES				
16	1/2" DIA. DRILL 10 HOLES				
17	1/2" DIA. DRILL 10 HOLES				
18	1/2" DIA. DRILL 10 HOLES				
19	1/2" DIA. DRILL 10 HOLES				
20	1/2" DIA. DRILL 10 HOLES				
21	1/2" DIA. DRILL 10 HOLES				
22	1/2" DIA. DRILL 10 HOLES				
23	1/2" DIA. DRILL 10 HOLES				
24	1/2" DIA. DRILL 10 HOLES				
25	1/2" DIA. DRILL 10 HOLES				
26	1/2" DIA. DRILL 10 HOLES				
27	1/2" DIA. DRILL 10 HOLES				
28	1/2" DIA. DRILL 10 HOLES				
29	1/2" DIA. DRILL 10 HOLES				
30	1/2" DIA. DRILL 10 HOLES				
31	1/2" DIA. DRILL 10 HOLES				
32	1/2" DIA. DRILL 10 HOLES				
33	1/2" DIA. DRILL 10 HOLES				
34	1/2" DIA. DRILL 10 HOLES				
35	1/2" DIA. DRILL 10 HOLES				
36	1/2" DIA. DRILL 10 HOLES				
37	1/2" DIA. DRILL 10 HOLES				
38	1/2" DIA. DRILL 10 HOLES				
39	1/2" DIA. DRILL 10 HOLES				
40	1/2" DIA. DRILL 10 HOLES				
41	1/2" DIA. DRILL 10 HOLES				
42	1/2" DIA. DRILL 10 HOLES				
43	1/2" DIA. DRILL 10 HOLES				
44	1/2" DIA. DRILL 10 HOLES				
45	1/2" DIA. DRILL 10 HOLES				
46	1/2" DIA. DRILL 10 HOLES				
47	1/2" DIA. DRILL 10 HOLES				
48	1/2" DIA. DRILL 10 HOLES				
49	1/2" DIA. DRILL 10 HOLES				
50	1/2" DIA. DRILL 10 HOLES				

**- NOTE -**  
 The legibility of this drawing is substandard and may result in poor microfilm reproduction.















REFERENCE DRAWINGS	
DWG. No.	TITLE
B-39	SIDE ROLLER DETAILS FOR VERT. LIFT GATE
A-33	ASSEMBLY FOR VERT. LIFT GATE

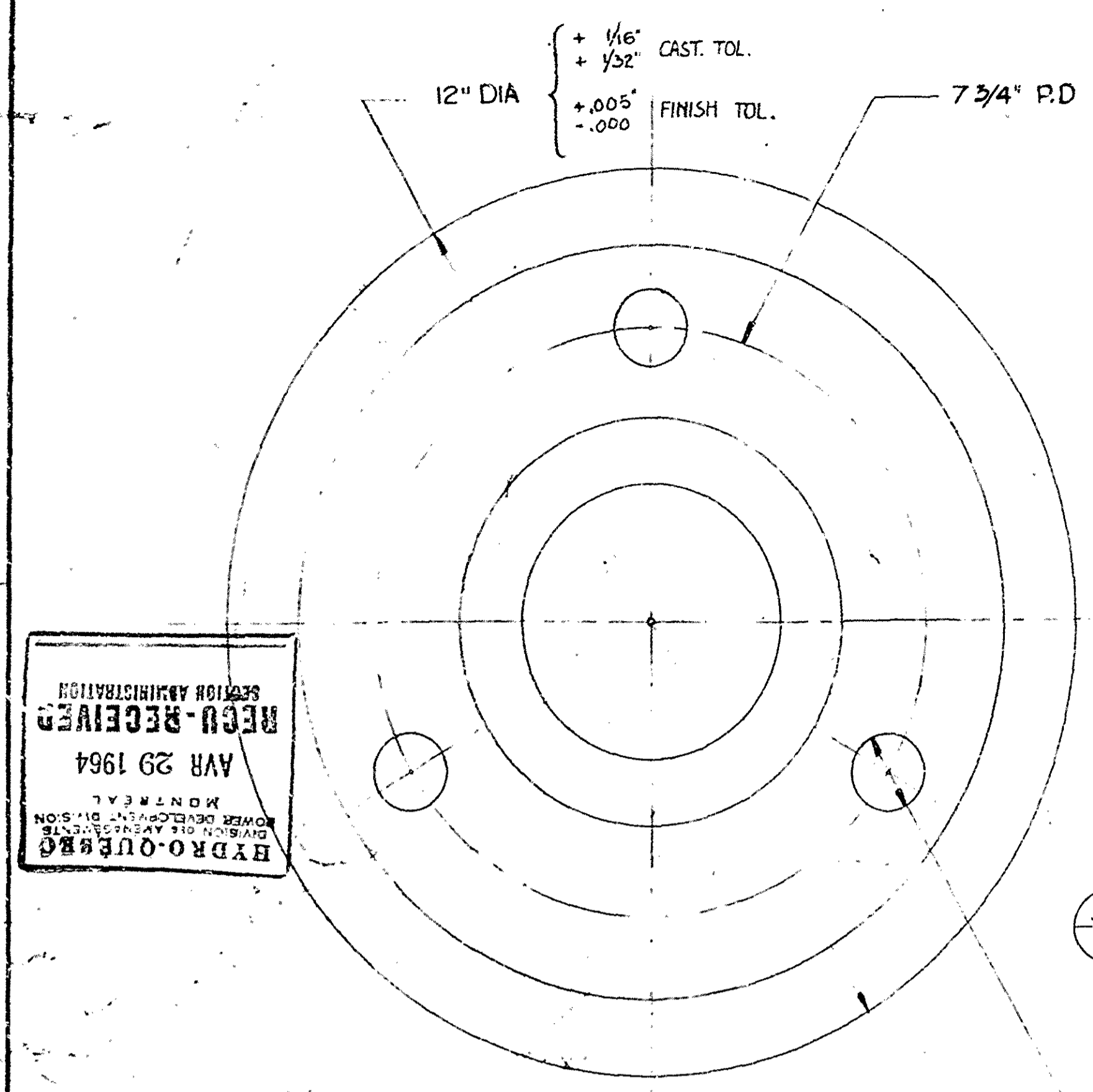

HYDRO-QUEBEC  
 DIVISION OF FEDERAL GOVERNMENT  
 1000 AVENUE DE LA MONTELLA  
 MONTREAL  
 MAR 29 1964  
 RECEIVED  
 SECTION ADMINISTRATION

(51)  
 1  
**ROLLER S11-12**  
 PATTERN N° G-16816  
 MAT'L: SPECIAL WHEEL IRON  
 RIM CHILLED  
 EST. FIN. WEIGHT: 61 lbs  
 EST. ROUGH WEIGHT: 101 lbs

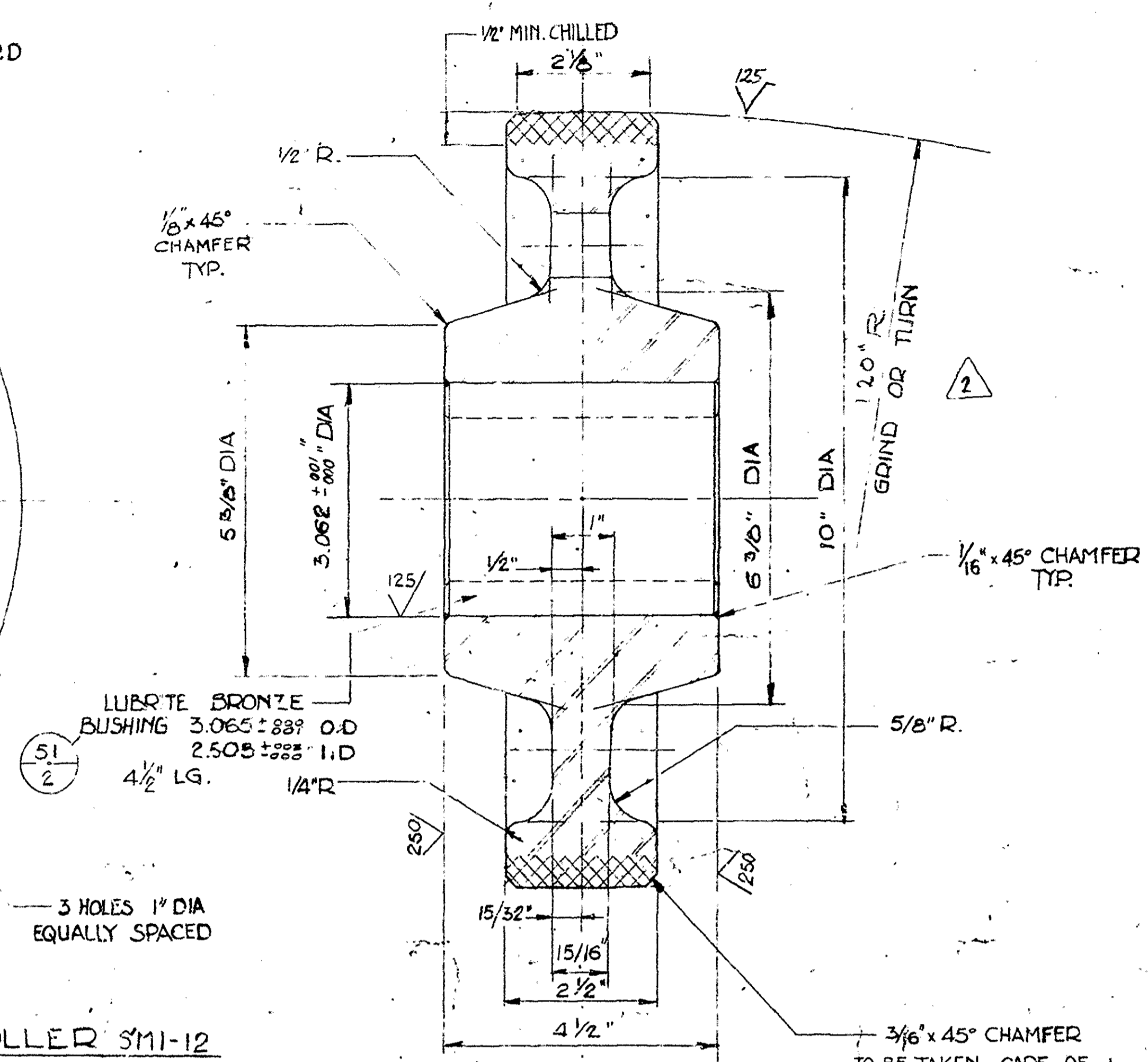

LUBRTE BRONZE  
 BUSHING 3.065 ± .002 O.D.  
 2.505 ± .002 I.D.  
 4 1/2 LG.

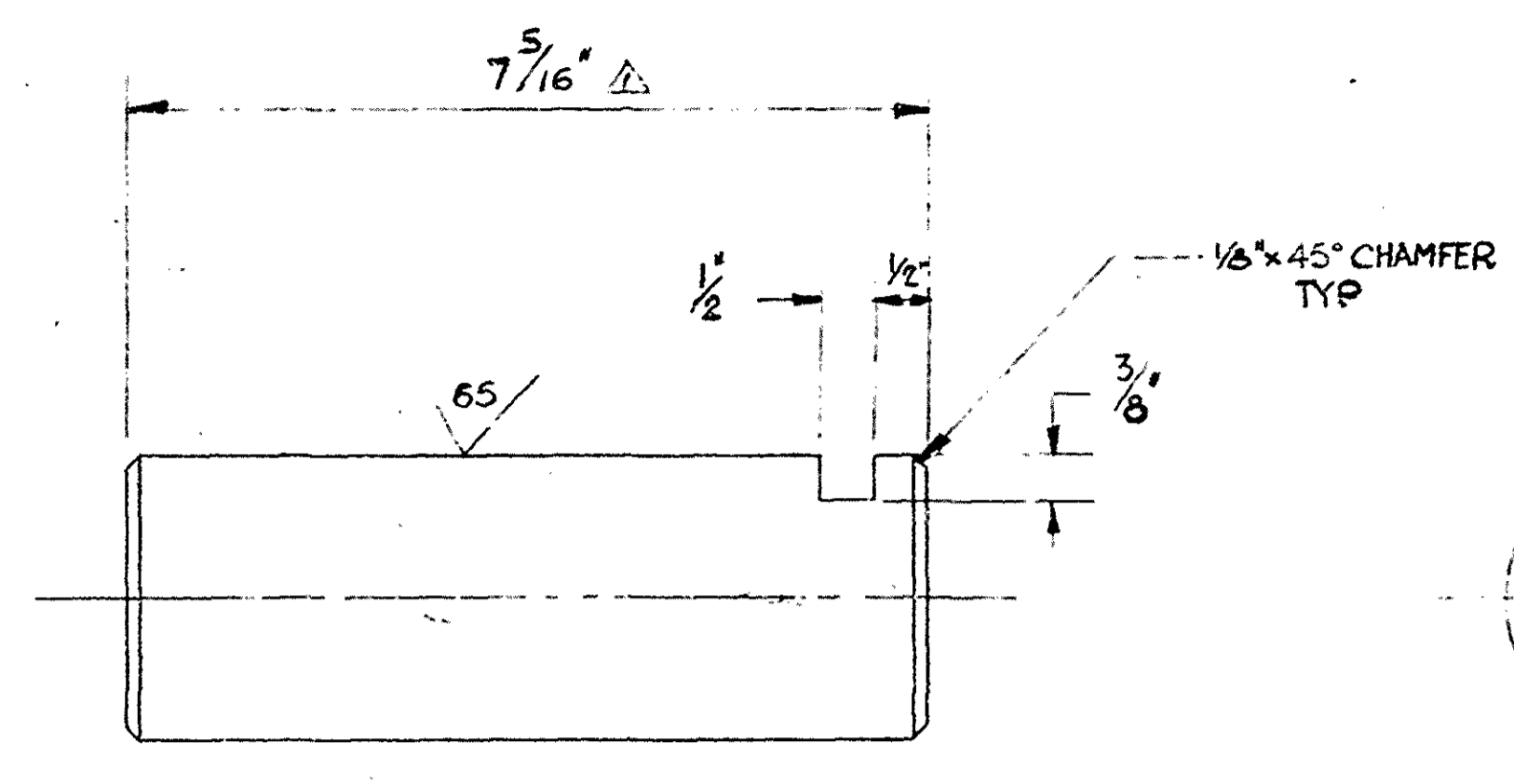

(51)  
 4  
**ROLLER AXLE**  
 MAT'L: SAE 5140

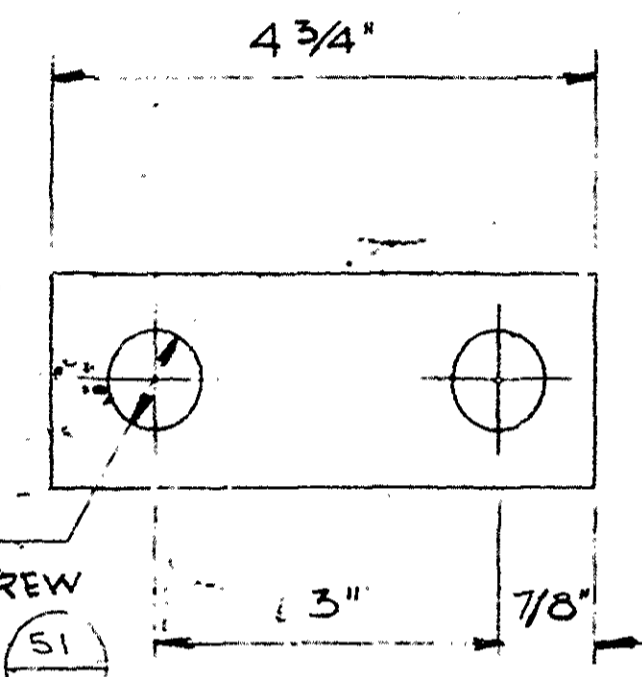

(51)  
 5  
**KEEPER PLATE**  
 MAT'L: A-36

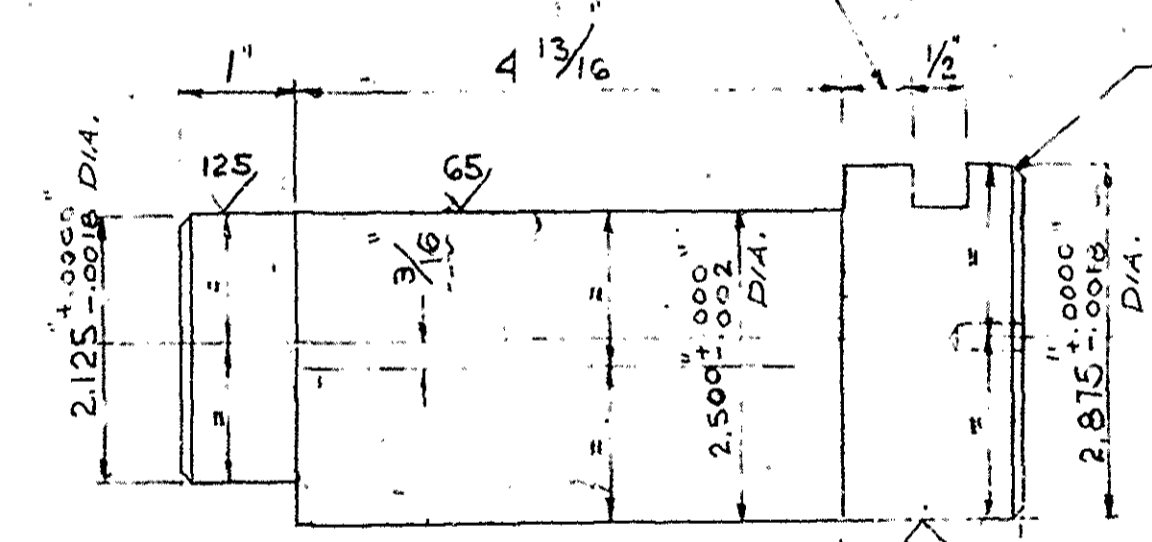

(51)  
 7  
**ECCENTRIC ROLLER AXLE**  
 MAT'L: SAE 5140

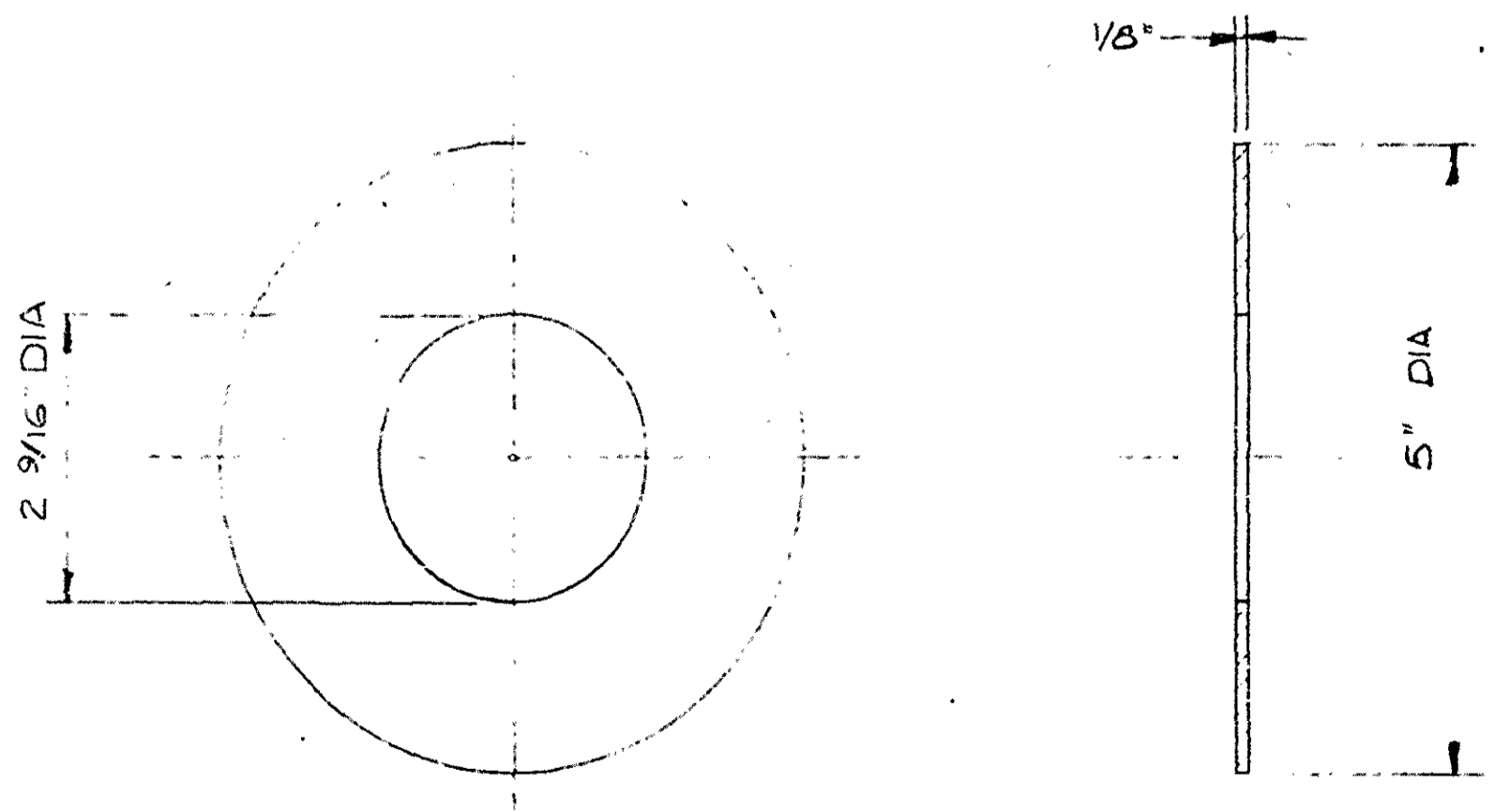

(51)  
 3  
**WASHER**  
 MAT'L: HALF HARD BRASS

FIELD NOTE:  
 KEEPER PLATE TO BE WELDED IN FIELD (3/16" FILLET WELD  
 3 SIDES) AFTER ADJUSTMENT OF THE ECCENTRIC  
 ROLLER AXLE

NOTE: FOR PAINTING INSTRUCTIONS AND  
 SURFACE PROTECTION SEE DWG 67

THIS DRAWING AND ALL COPIES HEREOF, AS WELL AS ALL TECHNICAL INFORMATION APPEARING  
 HEREON, ARE THE PROPERTY OF CANADIAN VICKERS LIMITED, MONTREAL, CANADA, WHICH  
 RESERVES ALL RIGHTS OF COPYRIGHT. THE SAME MAY NOT BE USED OR REPRODUCED, IN WHOLE  
 OR IN PART, WITHOUT THE WRITTEN PERMISSION OF CANADIAN VICKERS LIMITED. ANY COPY  
 HEREOF ISSUED BY CANADIAN VICKERS LIMITED MUST BE KEPT CONFIDENTIAL AND USED BY THE  
 RECIPIENT ONLY FOR THE SPECIFIC PURPOSE FOR WHICH IT IS SO ISSUED AND, UNLESS OTHER-  
 WISE AGREED IN WRITING, MUST, UPON REQUEST, BE RETURNED TO CANADIAN VICKERS LIMITED.

DESIGNED	DRAWN	CHECKED	SUBMITTED	APPROVED
BY	J.R.	E.G.	WRG	SAB
DATE	JUNE 17 1961			

**CANADIAN VICKERS LIMITED**  
 MONTREAL, CANADA  
 INDUSTRIAL DIVISION  
**QUEBEC HYDRO-ELECTRIC COMMISSION**  
 CARILLON DEVELOPMENT - NAVIGATION LOCK SECTION  
**SIDE ROLLER DETAILS FOR VERTICAL LIFT GATE**  
 CONSULTING ENGINEER: SHAWINGAN ENGINEERING CO.

No.	ZONE	PARTICULARS	DATE	BY
1		ECCENTRIC ROLLER AXLE & KEEPER PLATE ADDED	1 SEPT 61	AA
2		DIMENSION 120 W/LS 26	14 NOV 61	AA/E.G.
3		GENERAL REVISIONS	26 JUL 61	E.2.

Spec. Pg.	Fitt. No.	Job Number	Date	Sett Off	Req'n No.	Remarks
51		21962				

SCALE	CONTRACT NO.	DRAWING NUMBER	REVISION NO.
HALF SIZE	21962	B-40	14

- NOTE -  
 The legibility of this drawing  
 is substandard and may result  
 in poor microfilm reproduction.



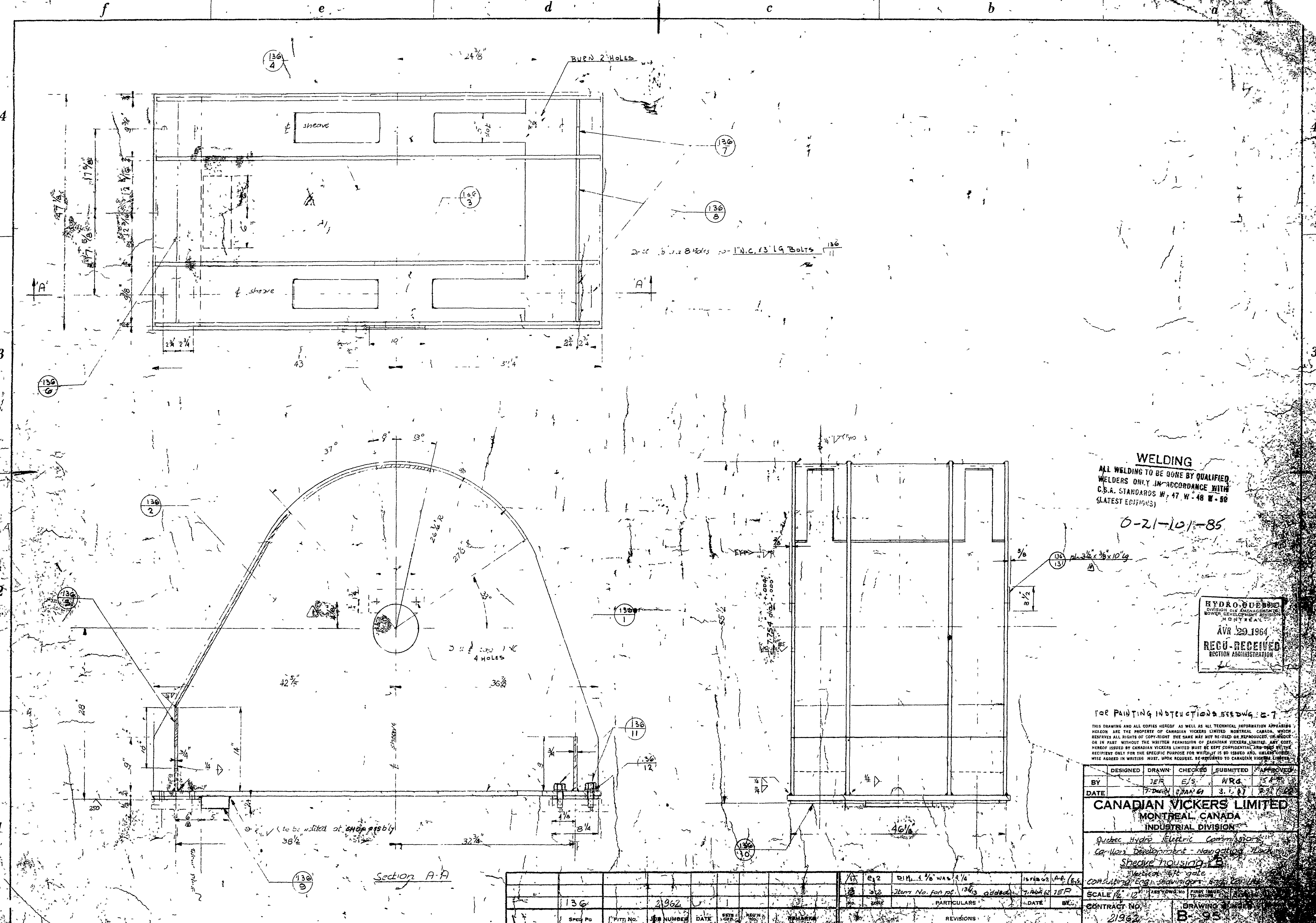

**WELDING**  
 ALL WELDING TO BE DONE BY QUALIFIED  
 WELDERS ONLY IN ACCORDANCE WITH  
 C.S.A. STANDARDS W 47, W 48, W 50  
 (LATEST EDITIONS)

0-21-101-85

HYDRO-QUEBEC  
 DIVISION OF ADVANCED DEVELOPMENT  
 MONTREAL  
 AVR 29 1964  
 REGU-RECEIVED  
 SECTION ADMINISTRATION

FOR PAINTING INSTRUCTIONS SEE DWG. C-7

THIS DRAWING AND ALL COPIES HEREOF AS WELL AS ALL TECHNICAL INFORMATION APPEARING  
 HEREON ARE THE PROPERTY OF CANADIAN VICKERS LIMITED, MONTREAL, CANADA, WHICH  
 RESERVES ALL RIGHTS OF COPYRIGHT. THE SAME MAY NOT BE USED OR REPRODUCED, IN WHOLE  
 OR IN PART, WITHOUT THE WRITTEN PERMISSION OF CANADIAN VICKERS LIMITED. ANY COPY  
 HEREOF ISSUED BY CANADIAN VICKERS LIMITED MUST BE KEPT CONFIDENTIAL AND MAY BE  
 REPRODUCED ONLY FOR THE SPECIFIC PURPOSE FOR WHICH IT IS ISSUED AND, UNLESS OTHER-  
 WISE AGREED IN WRITING, MUST, UPON REQUEST, BE RETURNED TO CANADIAN VICKERS LIMITED.

DESIGNED	DRAWN	CHECKED	SUBMITTED	APPROVED
BY	JER	E/S	NRG	
DATE	7 Dec 61	2 JAN 61	3.1.61	2.21.61

**CANADIAN VICKERS LIMITED**  
 MONTREAL, CANADA  
 INDUSTRIAL DIVISION

Quebec Hydro Electric Commission  
 Carillon Development - Navigation Works  
 Shedding housing - B

Consulting Engineer - Drawing No. 21962  
 SCALE 1/2" = 1'-0"  
 CONTRACT NO. 21962  
 DRAWING NO. B-95

NO.	DATE	REVISIONS
1		
2		
3		
4		
5		
6		
7		
8		
9		
10		
11		
12		

**- NOTE -**  
 The legibility of this drawing  
 is substandard and may result  
 in poor microfilm reproduction.



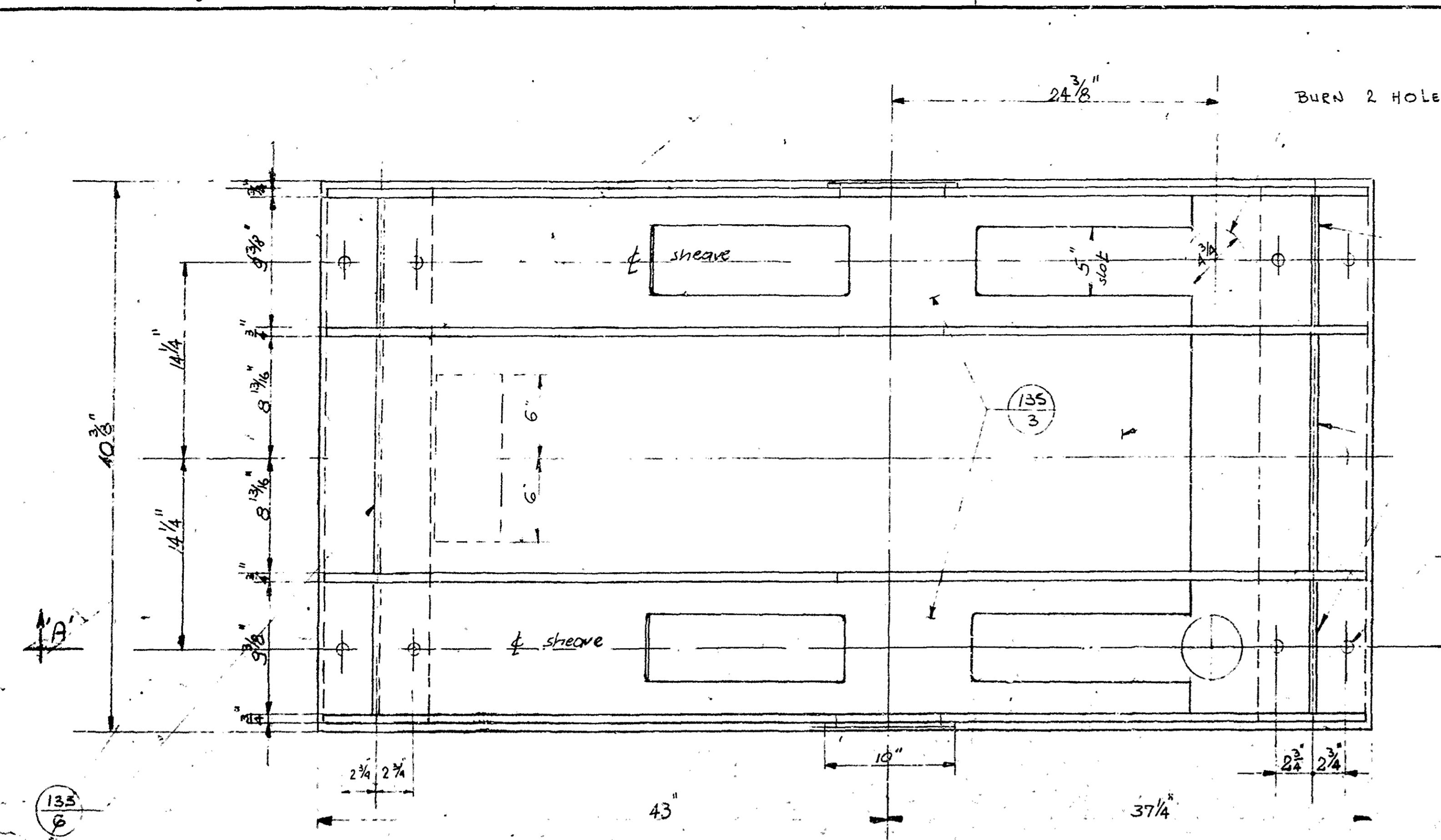

Drill 1/8 dia 8 holes for 1" N.C. x 3" Lg. BOLTS 135/11

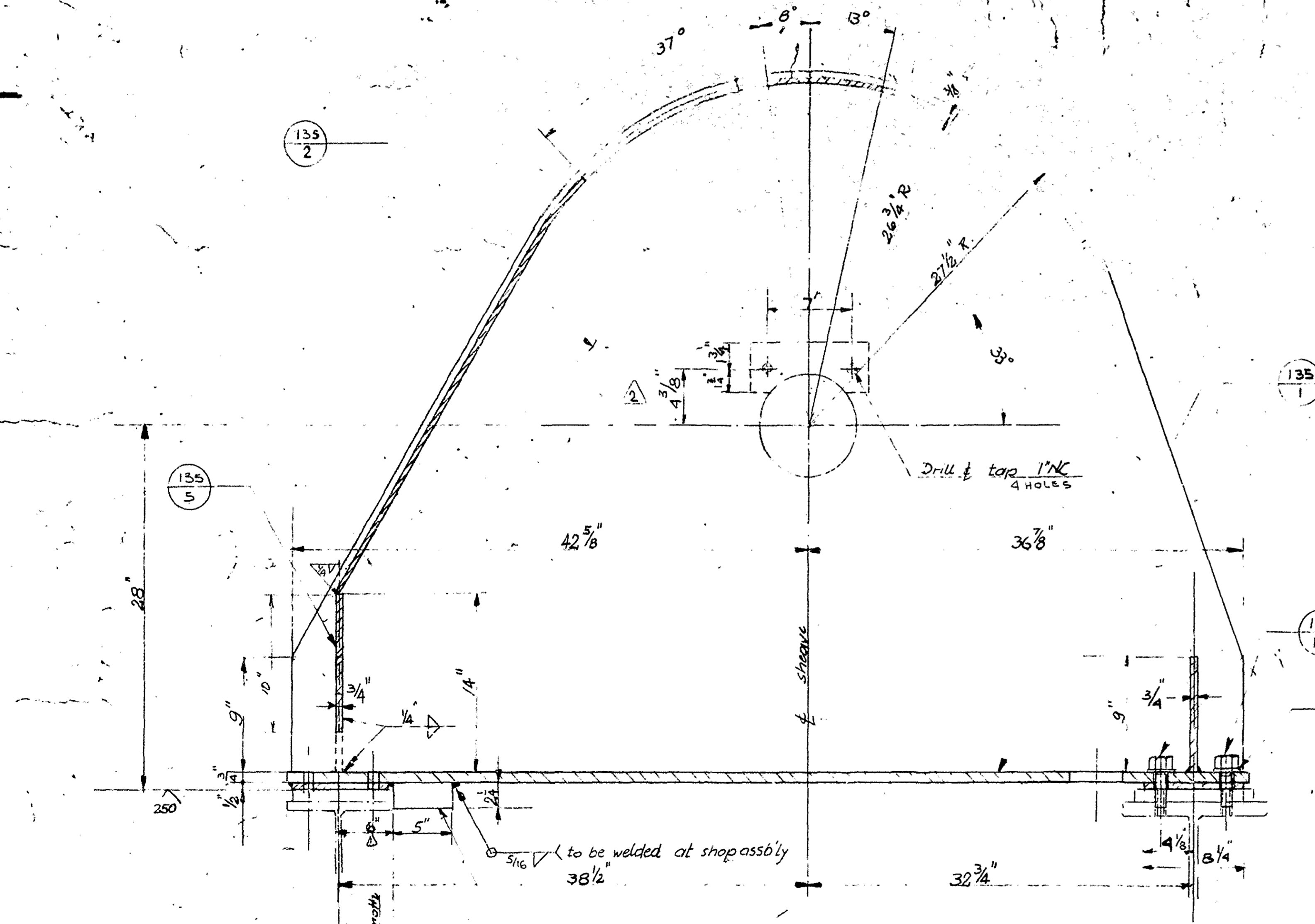

Section A-A

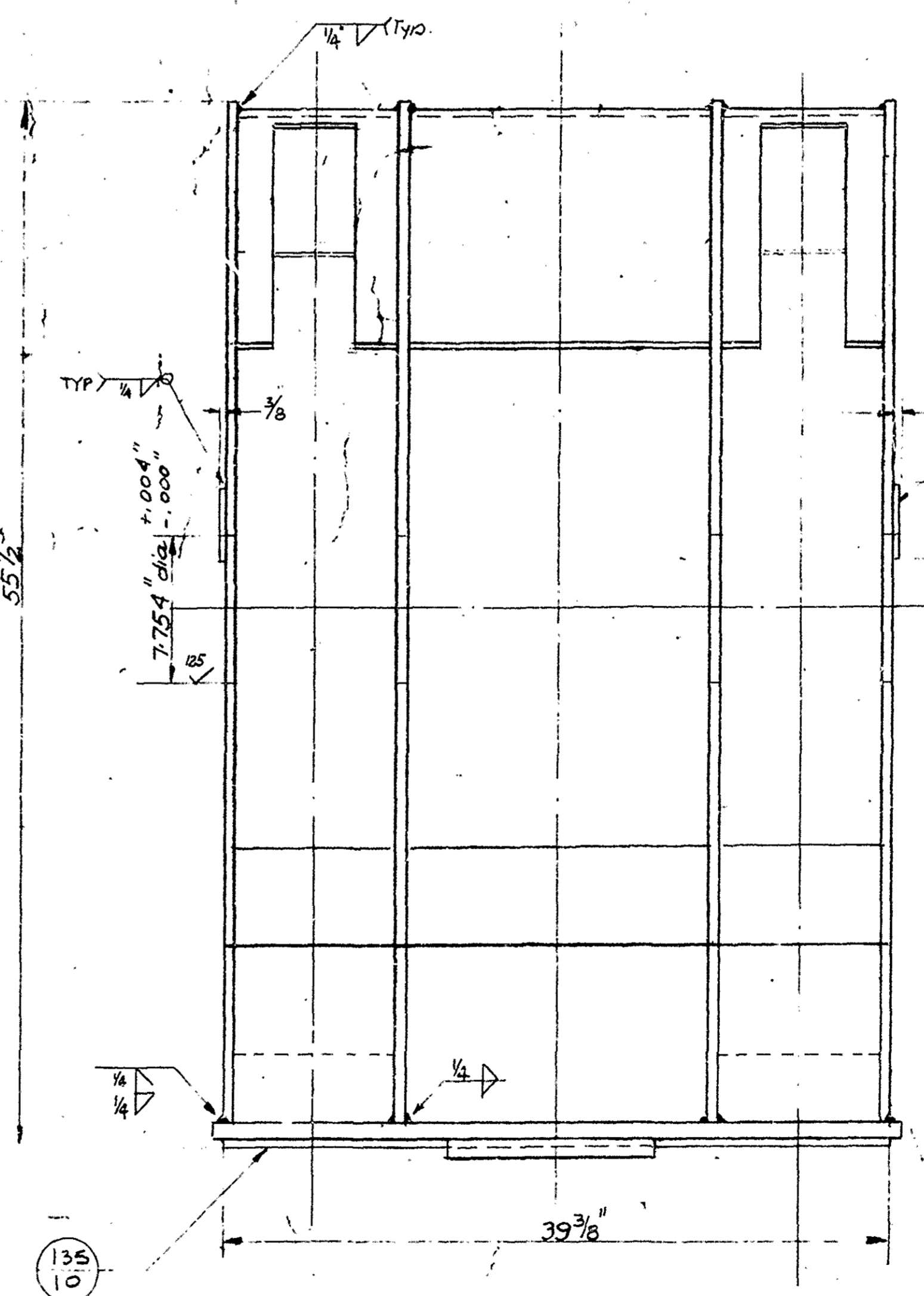

WELDING  
RE WELDING TO BE DONE BY QUALIFIED WELDER IN ACCORDANCE WITH C.S.C. 1962  
0-21-101-65

HYDRO-QUEBEC  
DIVISION DE LA PRODUCTION  
MONTREAL  
AVR 29 1964  
RECU-RECEIVED  
SECTION ADMINISTRATION

FOR PAINTING INSTRUCTION SEE DWG. C-7.

THIS DRAWING AND ALL COPIES HEREON, AS WELL AS ALL TECHNICAL INFORMATION APPEARING HEREON, ARE THE PROPERTY OF CANADIAN VICKERS LIMITED, MONTREAL, CANADA, WHICH RESERVES ALL RIGHTS OF COPYRIGHT. THE SAME MAY NOT BE USED OR REPRODUCED, IN WHOLE OR IN PART, WITHOUT THE WRITTEN PERMISSION OF CANADIAN VICKERS LIMITED. ANY COPY HEREOF ISSUED BY CANADIAN VICKERS LIMITED MUST BE KEPT CONFIDENTIAL AND USED BY THE RECIPIENT ONLY FOR THE SPECIFIC PURPOSE FOR WHICH IT IS SO ISSUED AND, UNLESS OTHERWISE AGREED IN WRITING, MUST, UPON REQUEST, BE RETURNED TO CANADIAN VICKERS LIMITED.

DESIGNED	DRAWN	CHECKED	SUBMITTED	APPROVED
BY	JEP	E.S.	WRG	S.H.M.
DATE	7 Dec 61	3 JAN 62	21 31	29.1.62

**CANADIAN VICKERS LIMITED**  
MONTREAL, CANADA  
INDUSTRIAL DIVISION

Quebec Hydro Electric Commission  
Carillon Development - Navigation Lock

Sheave housing "A"  
Vertical lift gate  
Consulting Eng. Shawinigan Eng Co. Ltd.

SCALE 1/2" = 12"  
ASS'Y DWG. N.J. FIRST ISSUE TO SHOPS  
DATE 20 JAN 62

CONTRACT NO. 21962  
DRAWING NUMBER B-27  
REVISION NO. 2

NO.	ZONE	PARTICULARS	DATE	BY
2	C, 2	DIMENSION 4 3/8 WAS 4 1/4	15 FEB 62	AW/c
	D-2	Item No. for pl. 7/8 added	7 Feb 62	JEP
		DRAWING REDRAWN	9 JAN 62	JEP

SPEC. PG.	FITT. NO.	JOB NUMBER	DATE	SETS OFF.	REQ'N NO.	REMARKS
		21962				

**NOTE**  
The legibility of this drawing is substandard and may result in poor microfilm reproduction.

1/2" DIA. ANCHORS TYPE "K"  
SEE DWG. "B-G"

1/2" DIA. ANCHORS TYPE "K"  
SEE DWG. "B-G"

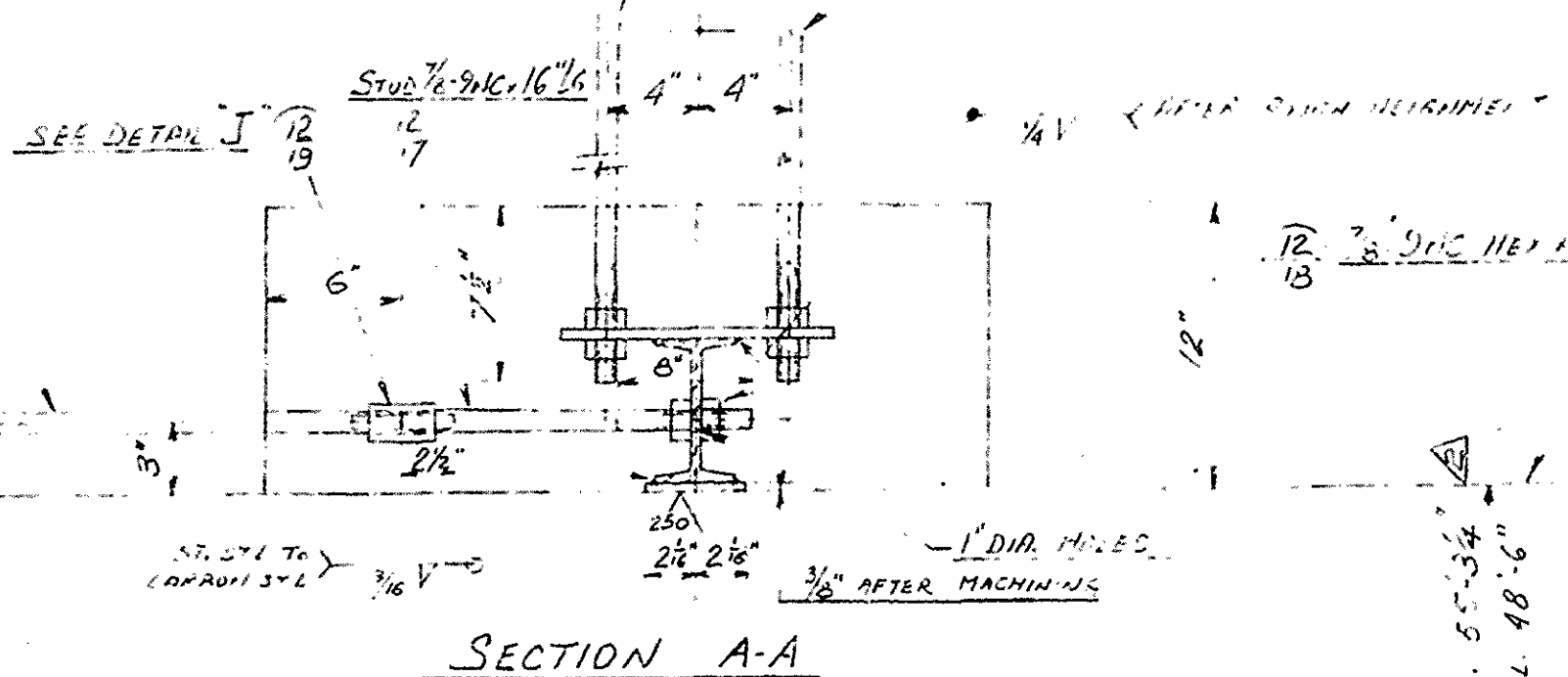

**FIELD NOTE:**  
SIDE SEAL PLATES TO BE ADJUSTED TO SUIT GATE DIMENSIONS AFTER ERECTION OF TANTOR VALVE. # TO BE GROUTED WITH GATE IN FULLY RAISED POSITION.

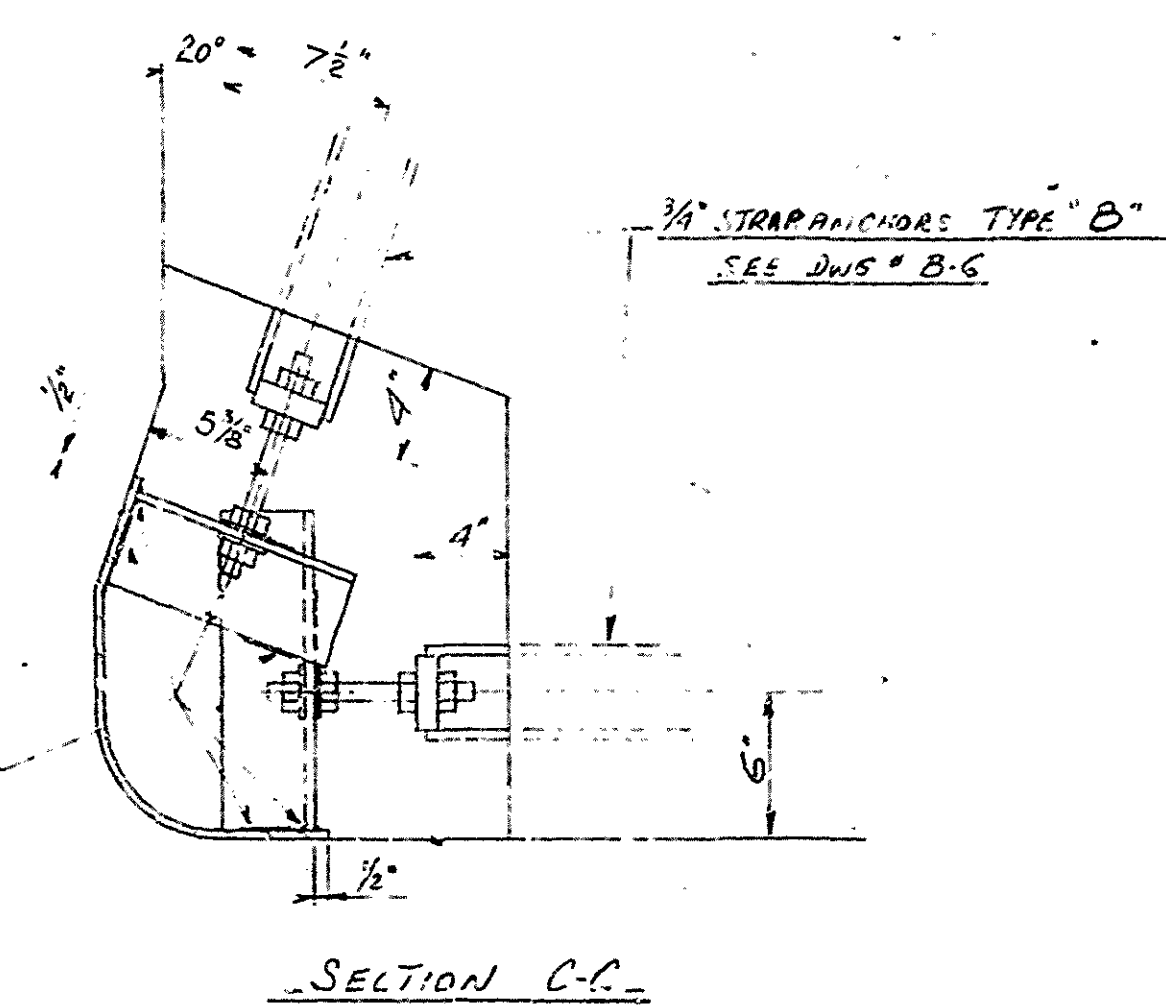
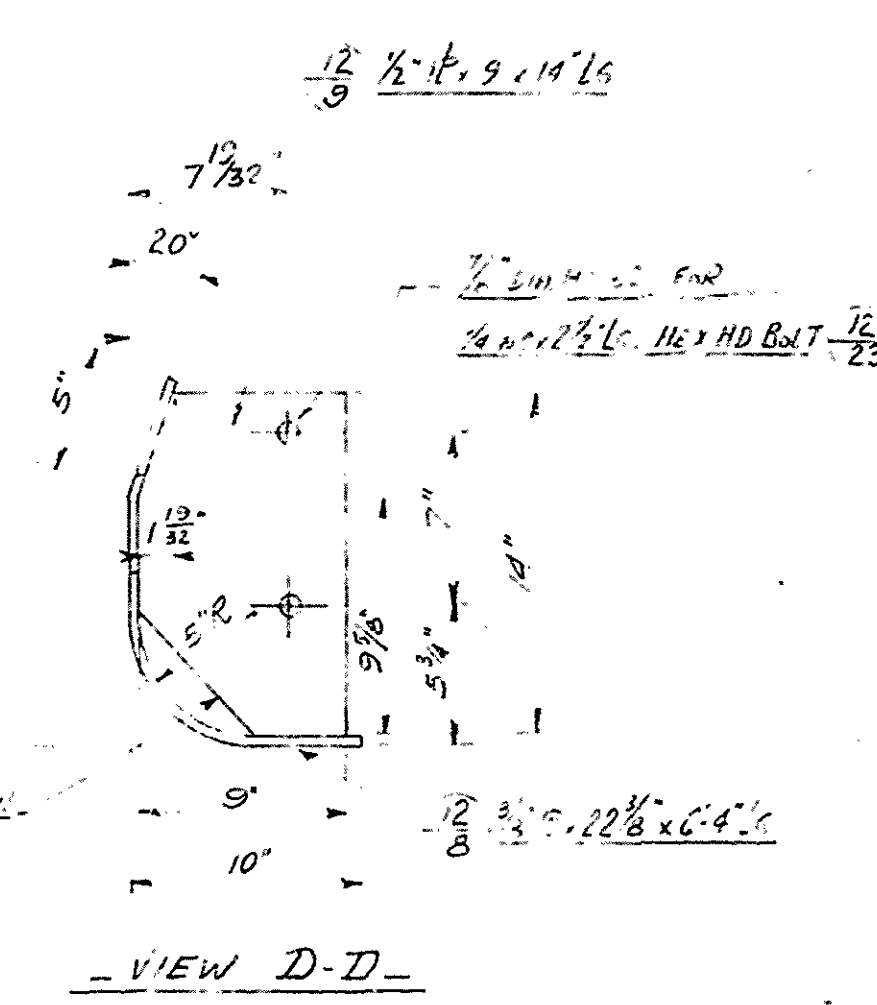

TRUNNION EL. 56.5

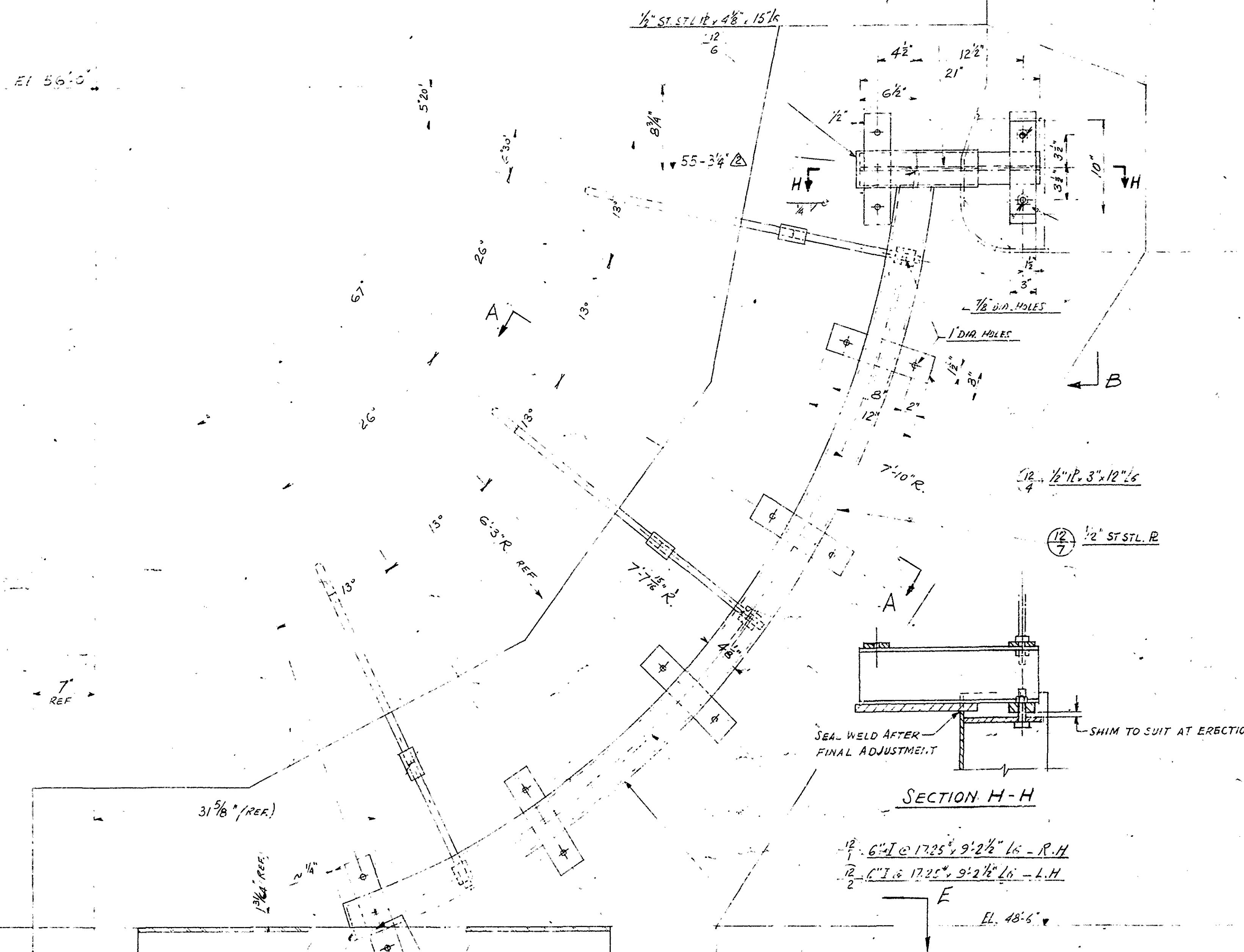

**SECTION H-H**  
1/2" ST. STEEL  
SEA. WELD AFTER FINAL ADJUSTMENT  
SHIM TO SUIT AT ERECTION

**NOTE:**  
SIDE SEAL RATE TO BE ADJUSTED BY MEANS OF THE ANCHOR BOLTS TO OBTAIN A TAPER OF 1/8" PER FT. VERTICALLY.

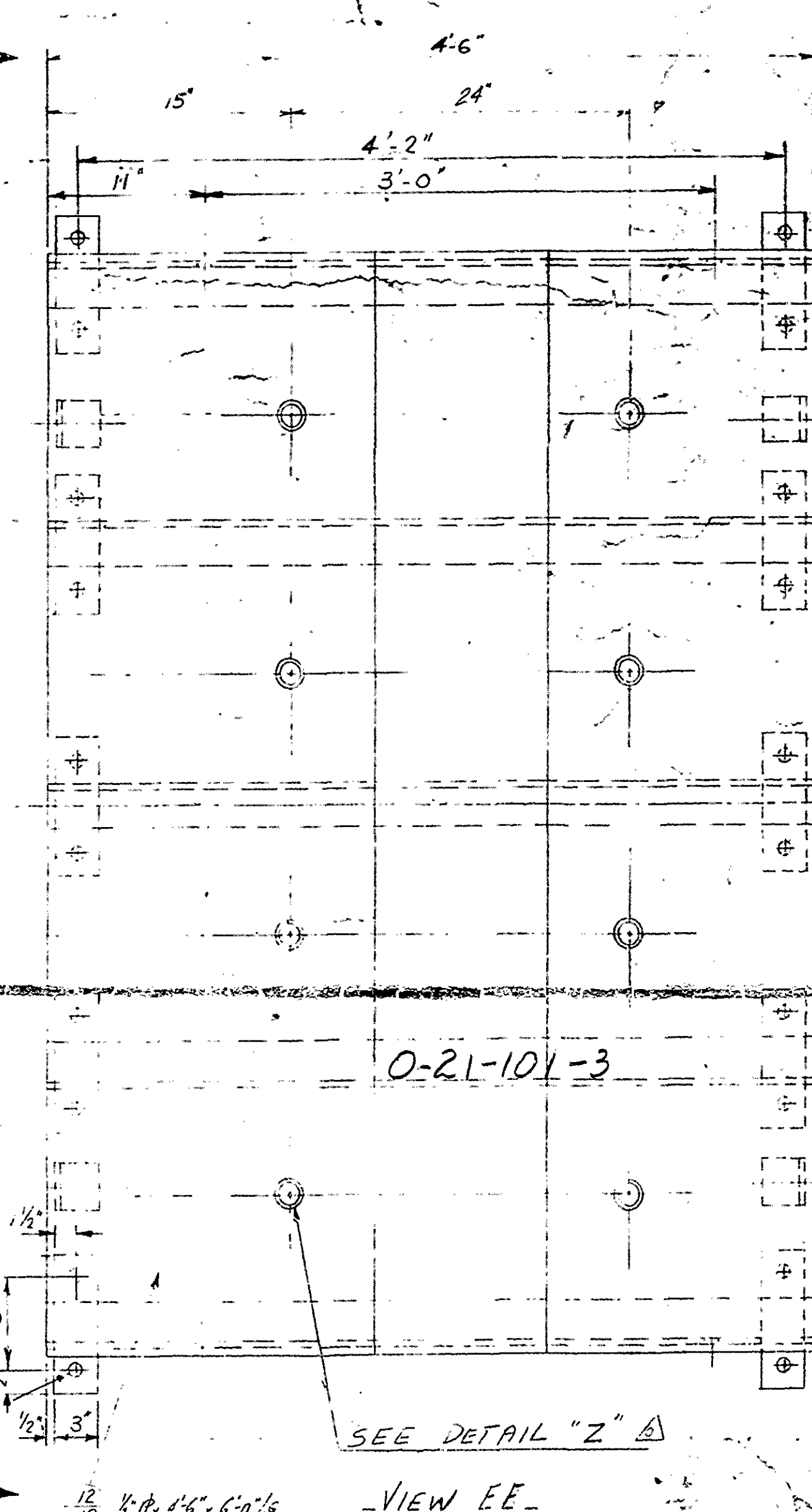
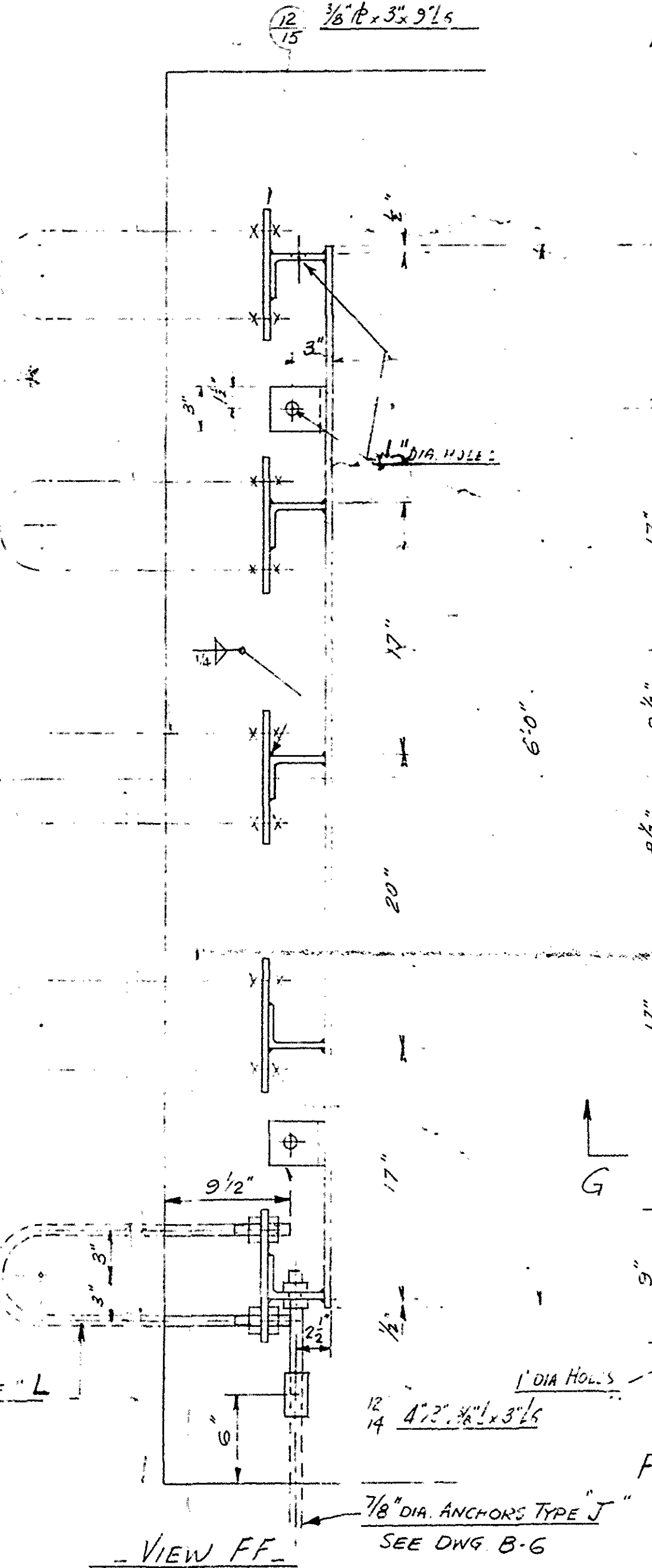
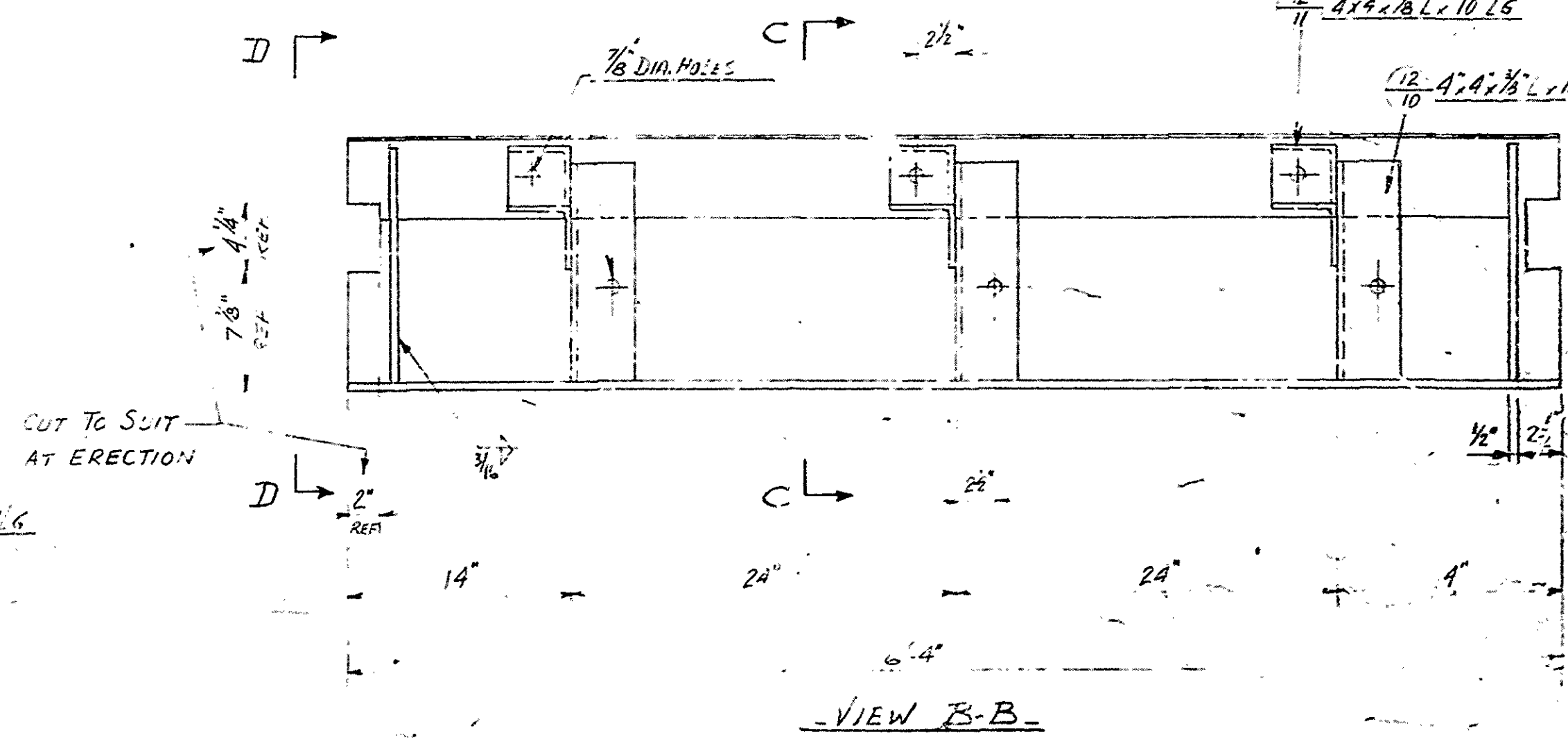

**INSTRUCTION FOR ERECTION:**  
1) RATE OF CONCRETE POUR = 3.5' PER HOUR  
LIFT OF CONCRETE = 6'-0" MAX.

**SECTION J-J**  
ANCHOR TYPE "J"  
SEE DWG. "B-G"

**DETAIL "Z"**  
SCALE: 3" = 1'-0"

**WELDING**  
ALL WELDING TO BE DONE BY QUALIFIED WELDERS ONLY IN ACCORDANCE WITH C.S.A. STANDARDS 1741 W-48 W-59 (LATEST EDITIONS)

**NOTE:** PAINTING, INTERIOR & EXTERIOR, PER DWG. "C-7"

DESIGNED	DRAWN	CHECKED	SUBMITTED	APPROVED
BY: MK	JL	NR G.	20.4.61	20.4.61
<b>CANADIAN VICKERS LIMITED</b> MONTREAL, CANADA INDUSTRIAL DIVISION QUEBEC HYDRO-ELECTRIC COMMISSION CHARLOTTEVILLE DEVELOPMENT - LAKE CHARLOTTE, QUEBEC				
TANTOR VALVE - EMBEDDED PART SCALE: 1/8" = 1'-0" (GENERAL) 1/4" = 1'-0" (DETAILS) CONTRACT NO. 27362 DRAWING NO. 0-21-101-3				

NO.	ZONE	PARTICULARS	DATE	BY
1				
2				

**NOTE**  
The legibility of this drawing is substandard and may result in poor microfilm reproduction.



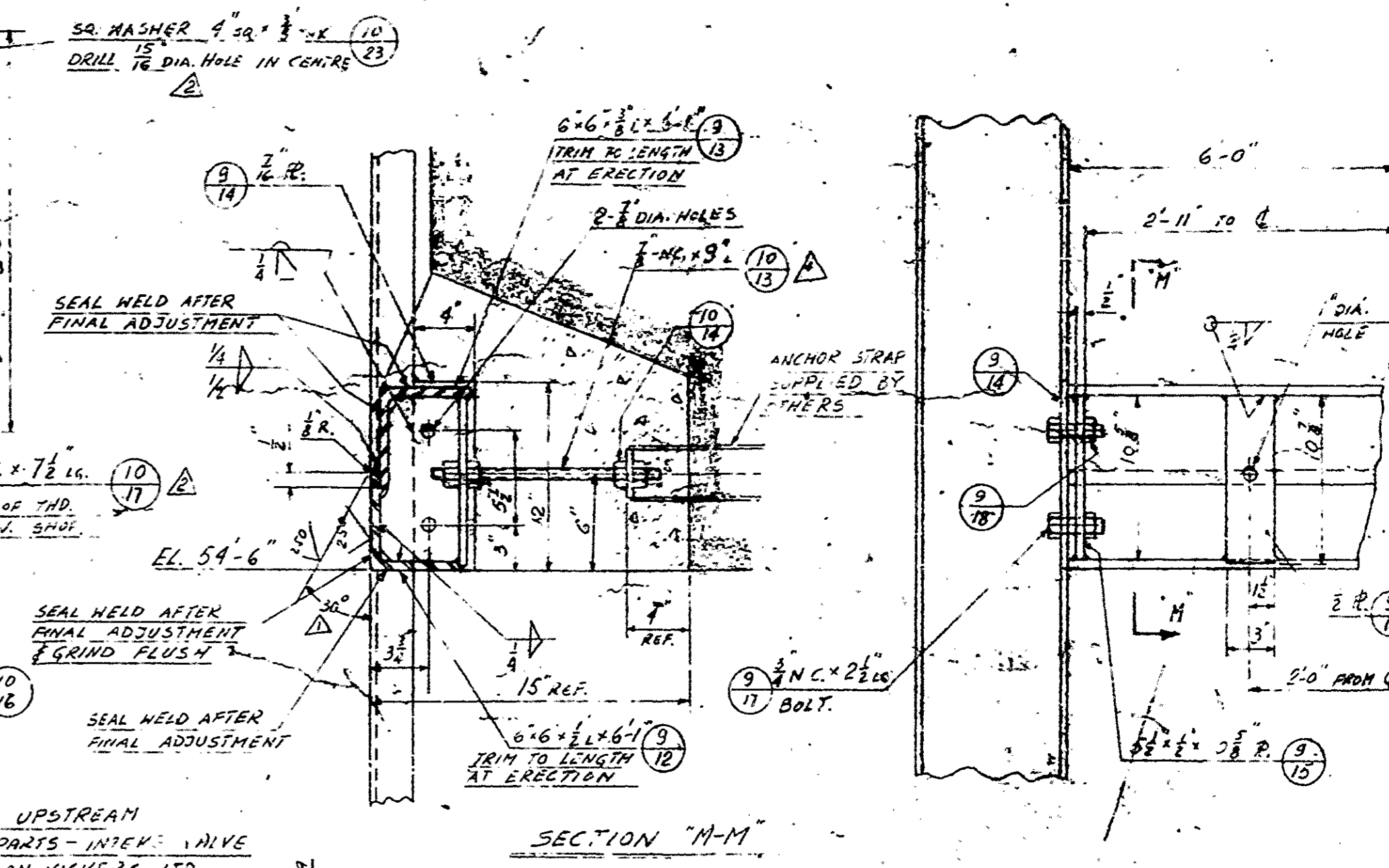
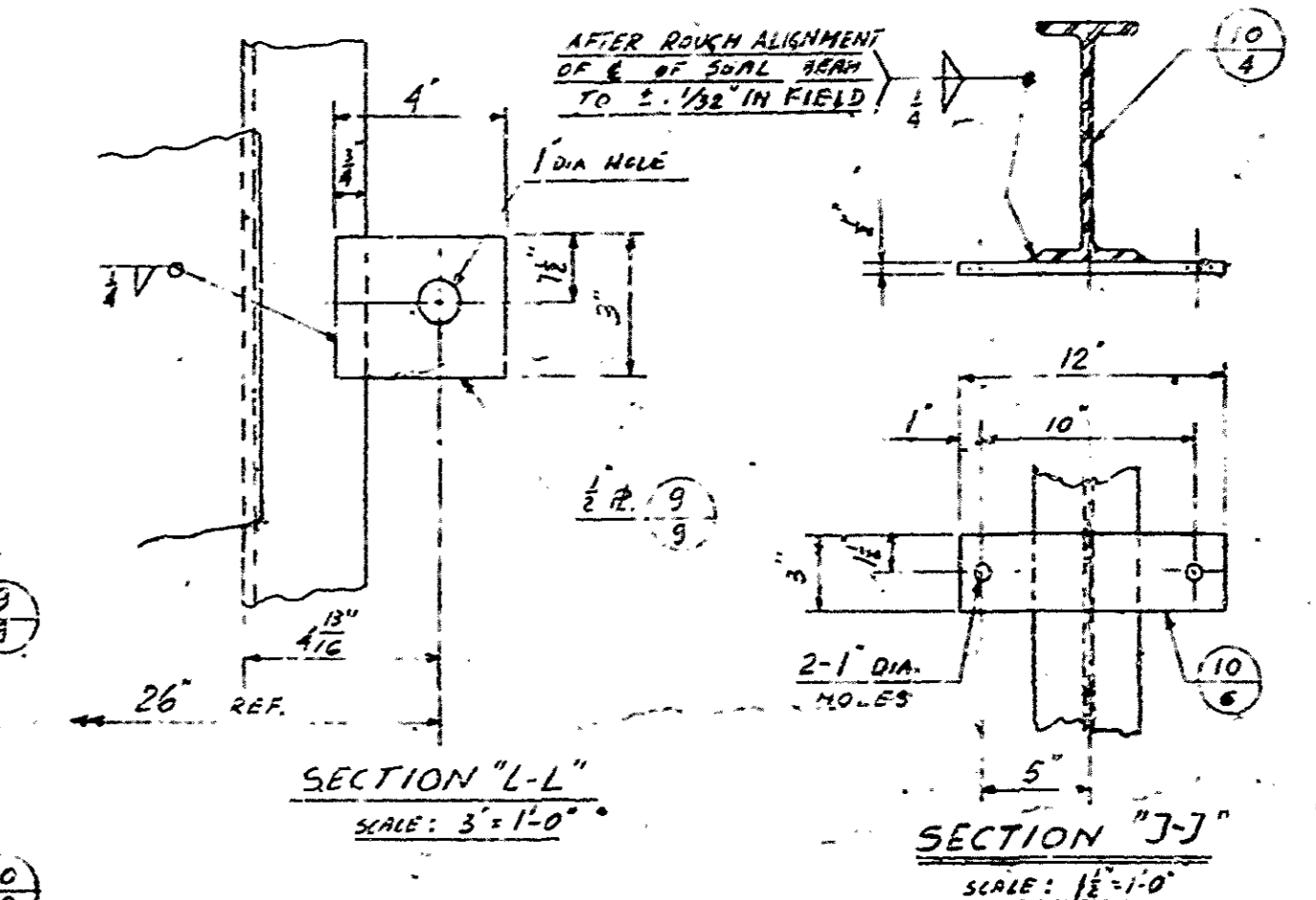
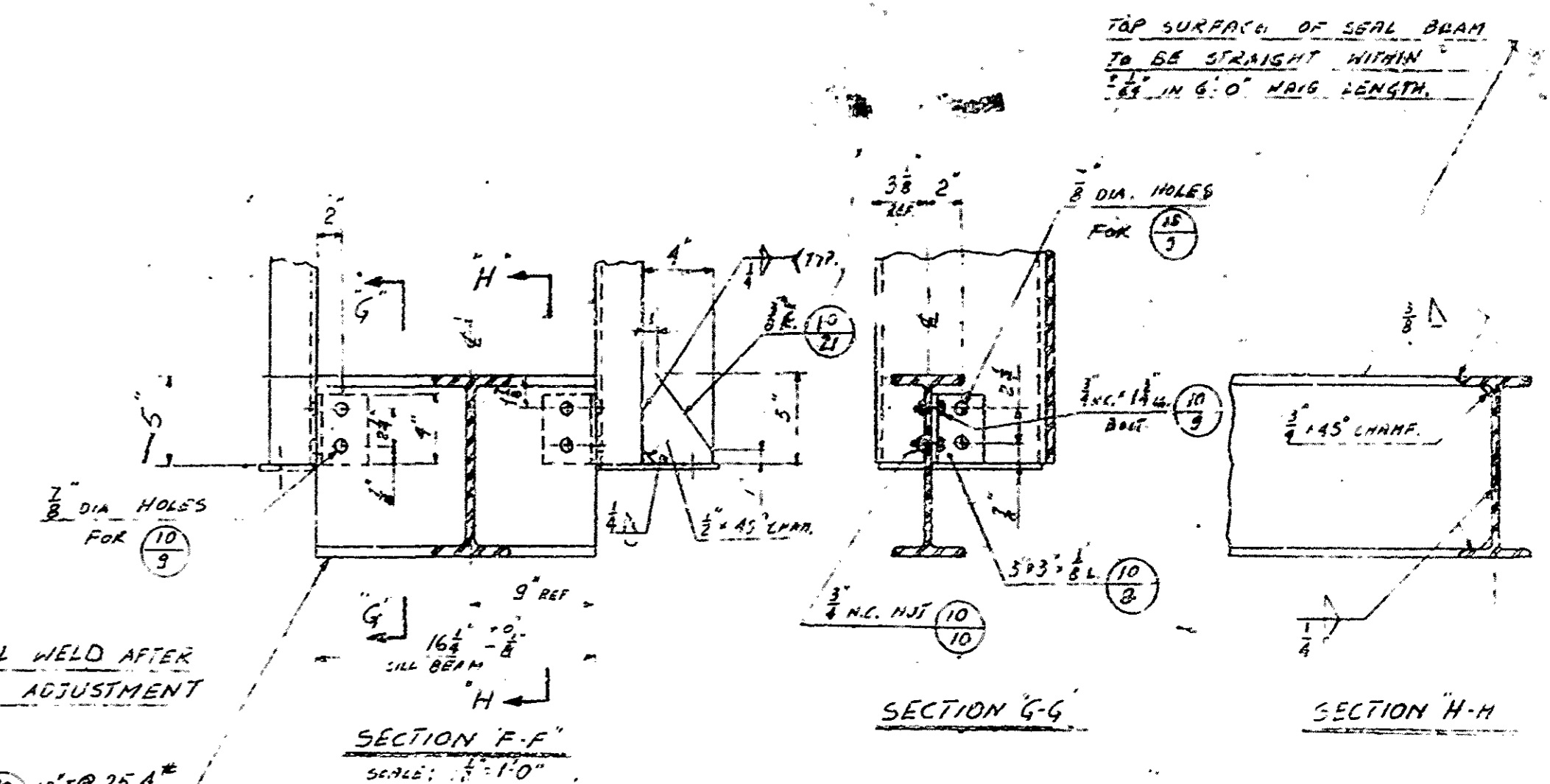
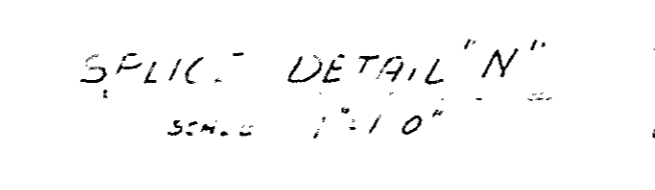
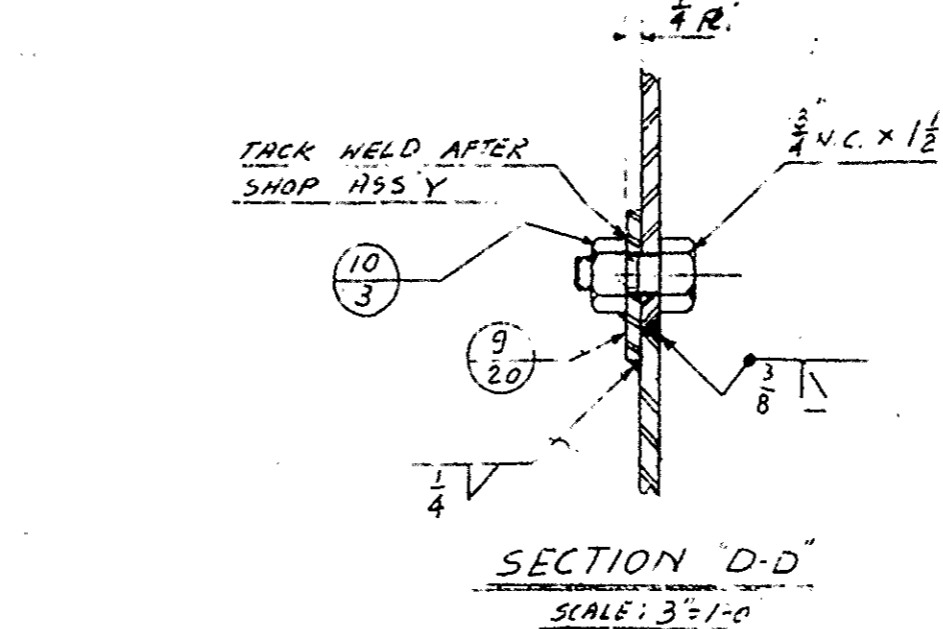
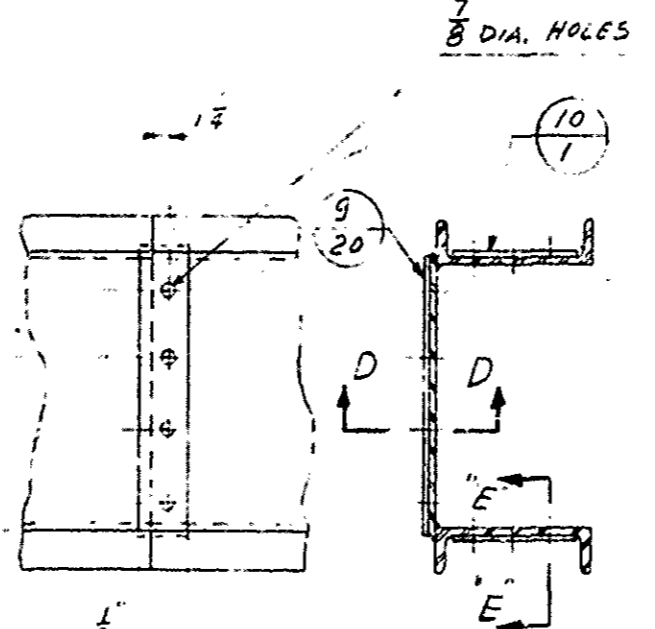
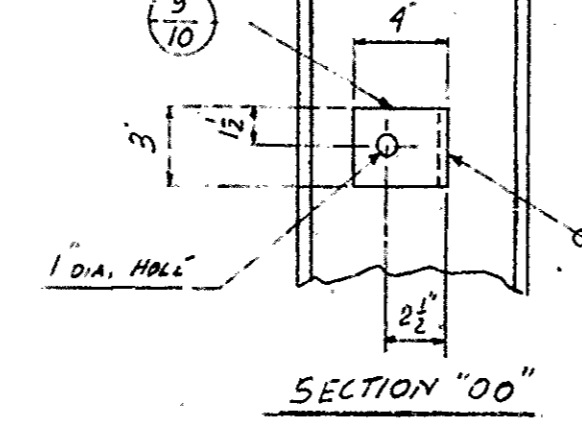
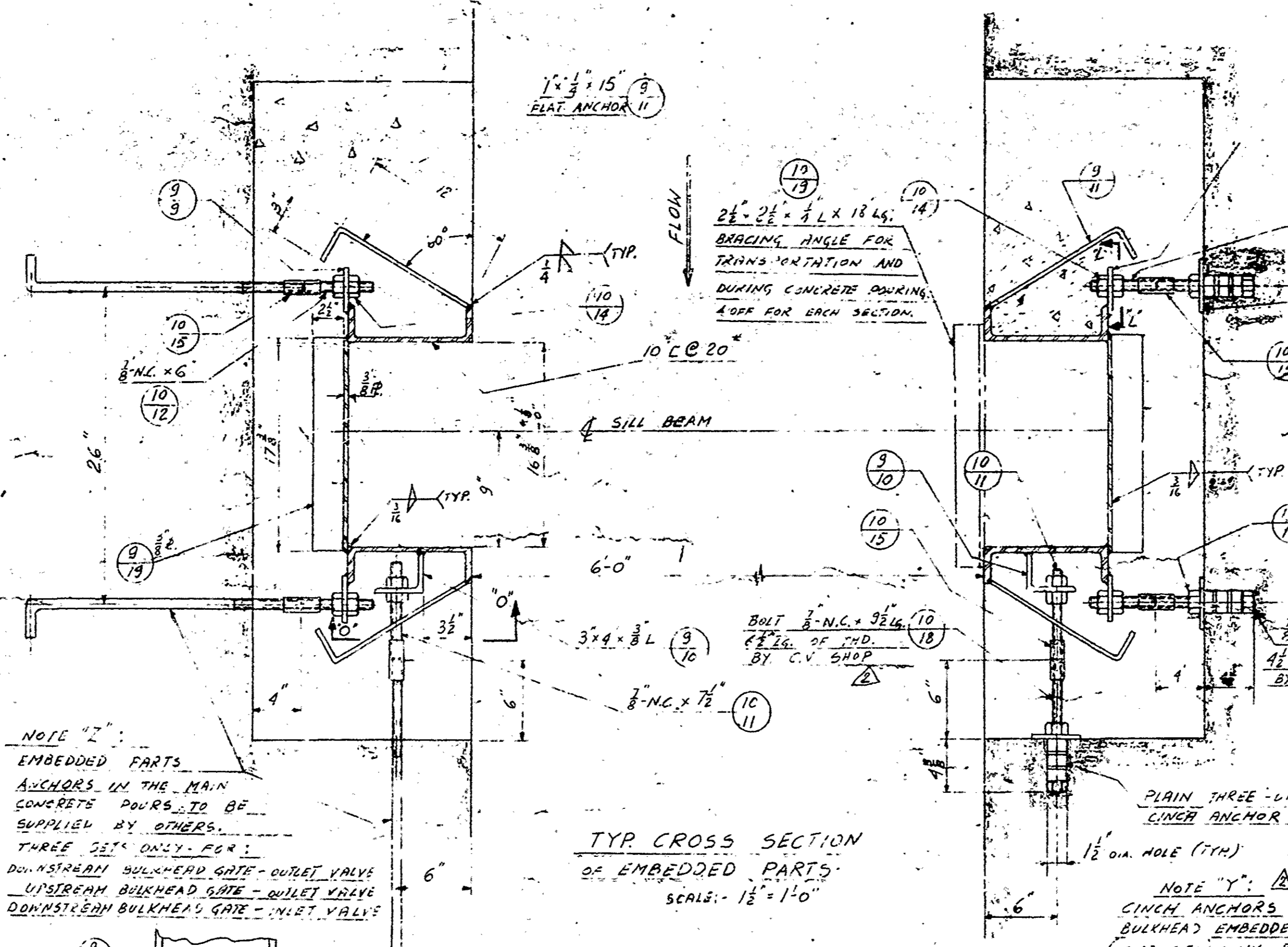
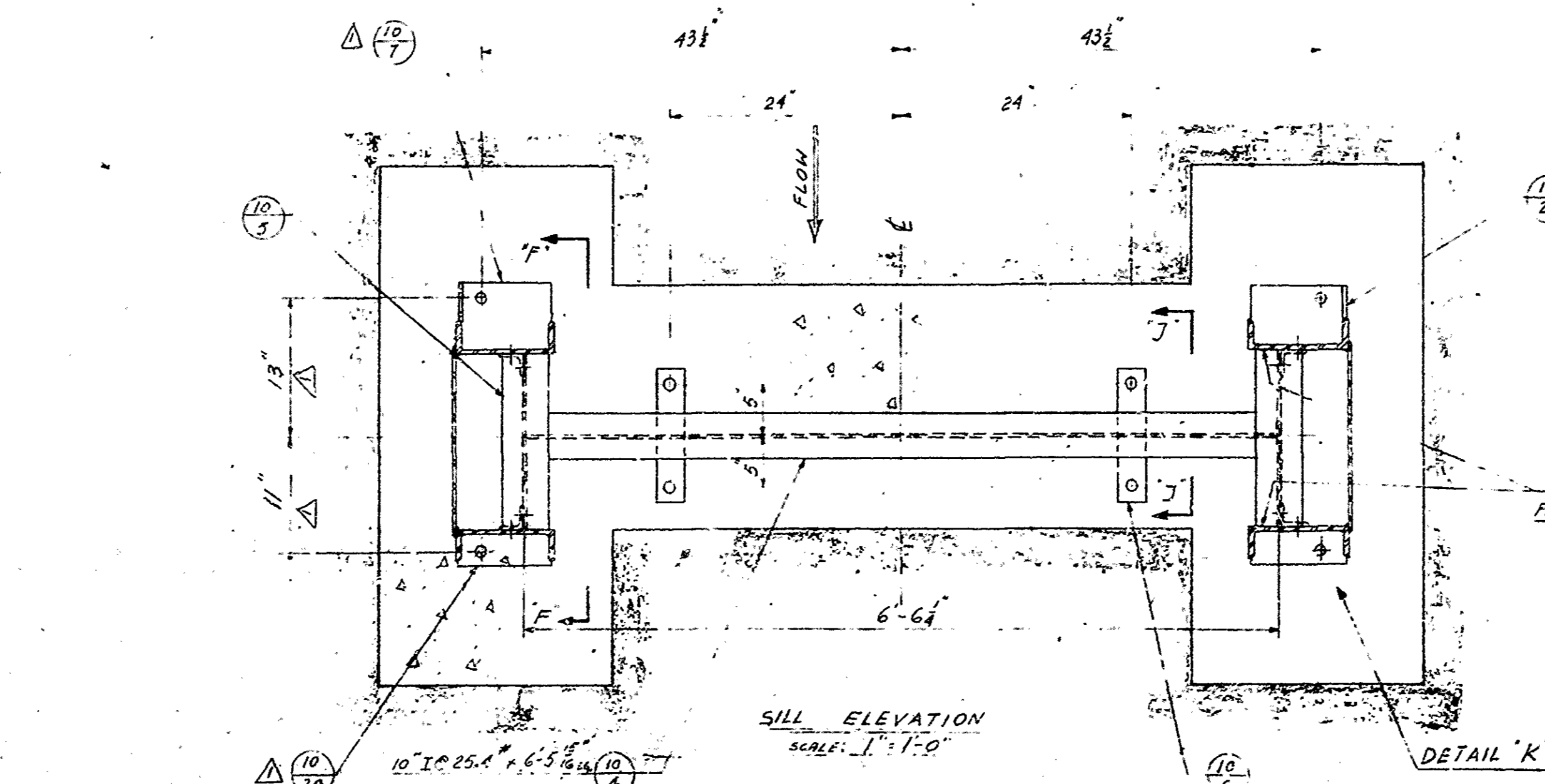
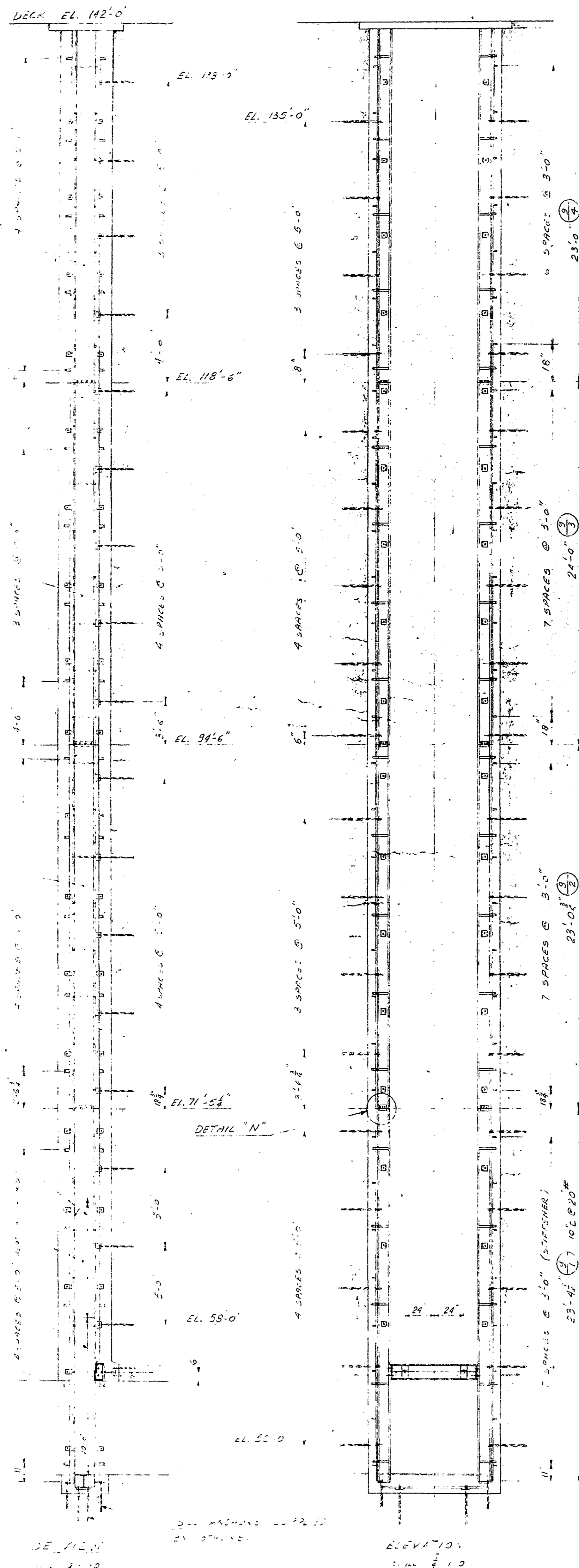

NOTE: 1. ASSEMBLE ANCHOR STUDS TO ANCHOR CLIPS BEFORE BRACING. 2. INSTRUCTION FOR ERECTION OF GAINS: RATE OF CONCRETE POUR 2.0 PER HOUR LIFT OF CONCRETE 6'-0\"/>

PAINTING INSTRUCTION AS PER DRAWING # C-7 WELDING ALL WELDS TO BE QUALIFIED

THIS DRAWING AND ALL COPIES HEREOF, AS WELL AS ALL TECHNICAL INFORMATION APPEARING HEREON, ARE THE PROPERTY OF CANADIAN VICKERS LIMITED, MONTREAL, QUEBEC, WHICH RECEIVES ALL RIGHTS OF COPYRIGHT. THE SAME MAY NOT BE USED OR REPRODUCED IN WHOLE OR IN PART, WITHOUT THE WRITTEN PERMISSION OF CANADIAN VICKERS LIMITED. ANY COPY RECEIVED BY CANADIAN VICKERS LIMITED MUST BE KEPT CONFIDENTIAL AND NOT TO BE REPRODUCED OR USED FOR ANY OTHER PURPOSE FOR WHICH IT IS ISSUED UNLESS OTHER WISE AGREED IN WRITING. MUST BE RETURNED TO CANADIAN VICKERS LIMITED.

DESIGNED	DRAWN	CHECKED	SUBMITTED	APPROVED
BY: A. S. WILSON	DATE: 11/1/62	DATE: 11/1/62	DATE: 11/1/62	DATE: 11/1/62
<b>CANADIAN VICKERS LIMITED</b> MONTREAL, CANADA INDUSTRIAL DIVISION				
QUEBEC HYDRO ELECTRIC COMMISSION CARILLON DEVELOPMENT - NAVIGATION LOCK SECTION BULKHEAD GATE EMBEDDED PARTS				
SCALE AS SHOWN				
CONTRACT NO. 21362 DRAWING NUMBER A-8				

NO.	ZONE	PARTICULARS	DATE	BY
1		REVISIONS		

**NOTE**  
The legibility of this drawing is substandard and may result in poor microfilm reproduction.



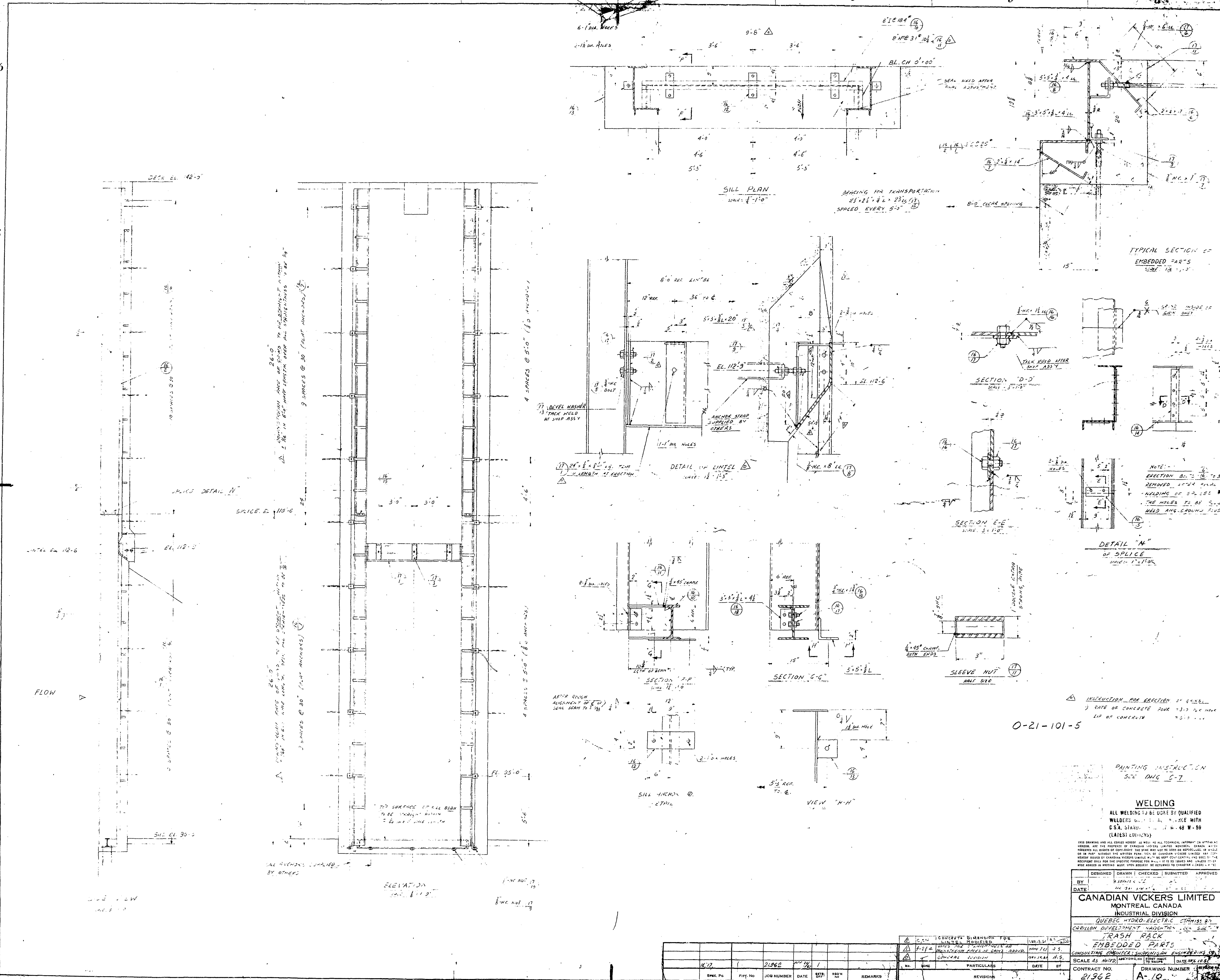

**INSTRUCTION FOR ERECTION OF 4-22-6**  
 1) RATE OF CONCRETE POUR 3-7' PER HOUR  
 2) LIF OF CONCRETE 5-10'

**PAINTING INSTRUCTION**  
 SEE DWG G-7

**WELDING**  
 ALL WELDING TO BE DONE BY QUALIFIED WELDERS WITH C.S.A. STAMP NO. W-48 W-59 (LATEST EDITIONS)

DESIGNED	DRAWN	CHECKED	SUBMITTED	APPROVED
BY	DATE	DATE	DATE	DATE
<b>CANADIAN VICKERS LIMITED</b>				
MONTREAL, CANADA				
INDUSTRIAL DIVISION				
QUEBEC HYDRO-ELECTRIC COMMISSION				
CORILLON DEVELOPMENT NAVIGATION				
<b>TRASH PART</b>				
<b>EMBEDDED PARTS</b>				
SCALE AS NOTED				
CONTRACT NO. 21962				
DRAWING NUMBER A-10				

NO.	REVISION	DATE	BY
1	ISSUED FOR CONSTRUCTION	1962	J.S.
2	REVISION	1962	J.S.
3	REVISION	1962	J.S.

**- NOTE -**  
 The legibility of this drawing is substandard and may result in poor microfilm reproduction.



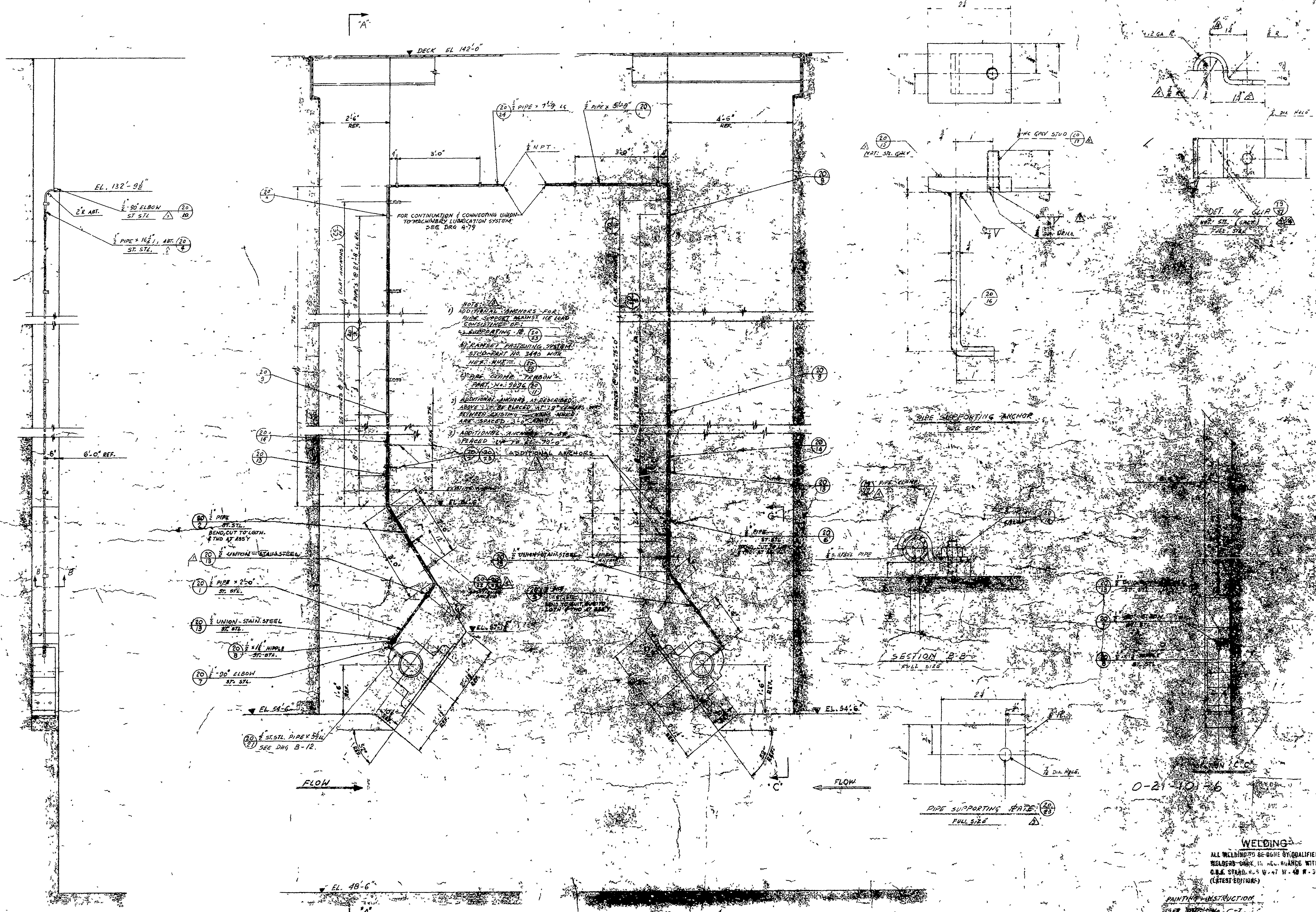

- NOTES:
- 1) ADDITIONAL ANCHORS FOR PIPE SUPPORT MAINS TO BE CONSIDERED UP.
  - 2) SUPPORTING BR.
  - 3) RANGET FASTENING SYSTEM STUD-BOLT NO. 3493 MUX HEE: NUT.
  - 4) PIPE CLAMP TO BE ON.
  - 5) ADDITIONAL ANCHORS AS DESCRIBED ABOVE TO BE PLACED AT 3' SPACING. REMAINING ANCHORS WHICH ARE SPACED 3' APART.
  - 6) ADDITIONAL ANCHORS TO BE SPACED UP TO EL. 70'-0".
  - 7) ADDITIONAL ANCHORS.

- 20 1/2" PIPE
- 20 1/2" UNION - STAINLESS
- 20 1/2" PIPE x 2'-0"
- 20 1/2" UNION - STAIN. STEEL
- 20 1/2" x 1/2" NIPPLE
- 20 1/2" 90° ELBOW
- 20 1/2" ST. STEEL PIPE x 3/4"

0-21-101-6

**WELDING**  
 ALL WELDING TO BE DONE BY QUALIFIED WELDERS ONLY IN ACCORDANCE WITH C.S.E. STAND. N.S.W. 47 W. 48 W. 39 (LATEST EDITIONS)

**PAINTING INSTRUCTION**  
 SEE DRAWING C-1

THIS DRAWING AND ALL CONTENTS HEREON ARE THE SOLE PROPERTY OF CANADIAN WICKERS LIMITED. ANY REPRODUCTION OR TRANSMISSION OF THIS DRAWING OR ANY CONTENTS HEREON WITHOUT THE WRITTEN PERMISSION OF CANADIAN WICKERS LIMITED IS STRICTLY PROHIBITED. THE LIABILITY FOR ANY DAMAGE OR LOSS OF PROFITS INCURRED BY ANY PARTY AS A RESULT OF THE USE OF THIS DRAWING OR ANY CONTENTS HEREON SHALL BE LIMITED TO THE EXTENT OF THE INSURANCE POLICY IN FORCE AND SHALL BE LIMITED TO THE AMOUNT OF THE INSURANCE POLICY IN FORCE.

DESIGNED	DRAWN	CHECKED	SUBMITTED	APPROVED

**CANADIAN WICKERS LIMITED**  
 MONTREAL, CANADA  
 INDUSTRIAL DIVISION

NO.	REV.	DATE	DESCRIPTION	BY	CHKD.	APP'D.
1	1					
2	1					
3	1					
4	1					
5	1					
6	1					
7	1					
8	1					
9	1					
10	1					

- NOTE -  
 The legibility of this drawing is substandard and may result in poor microfilm reproduction.



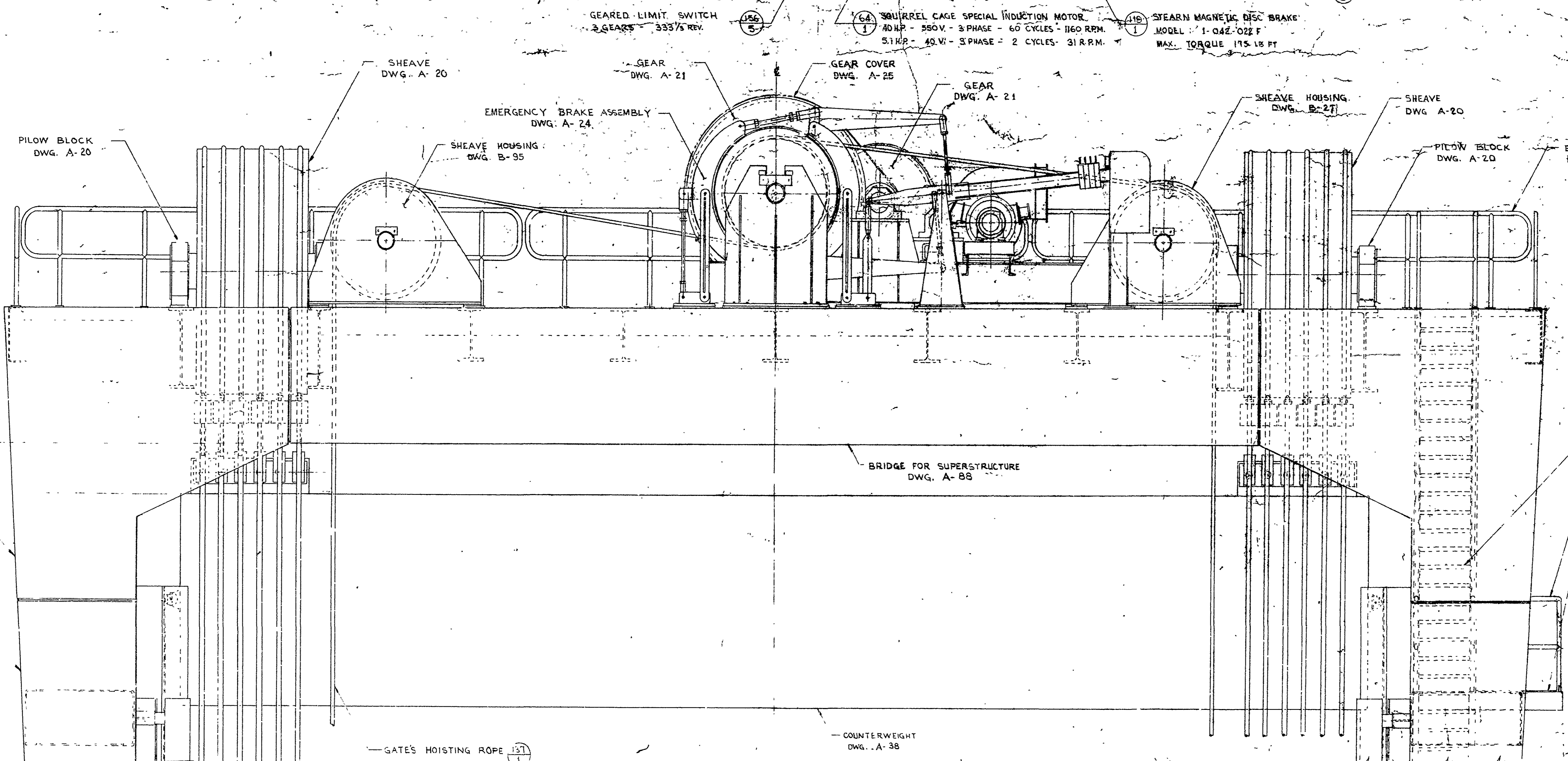
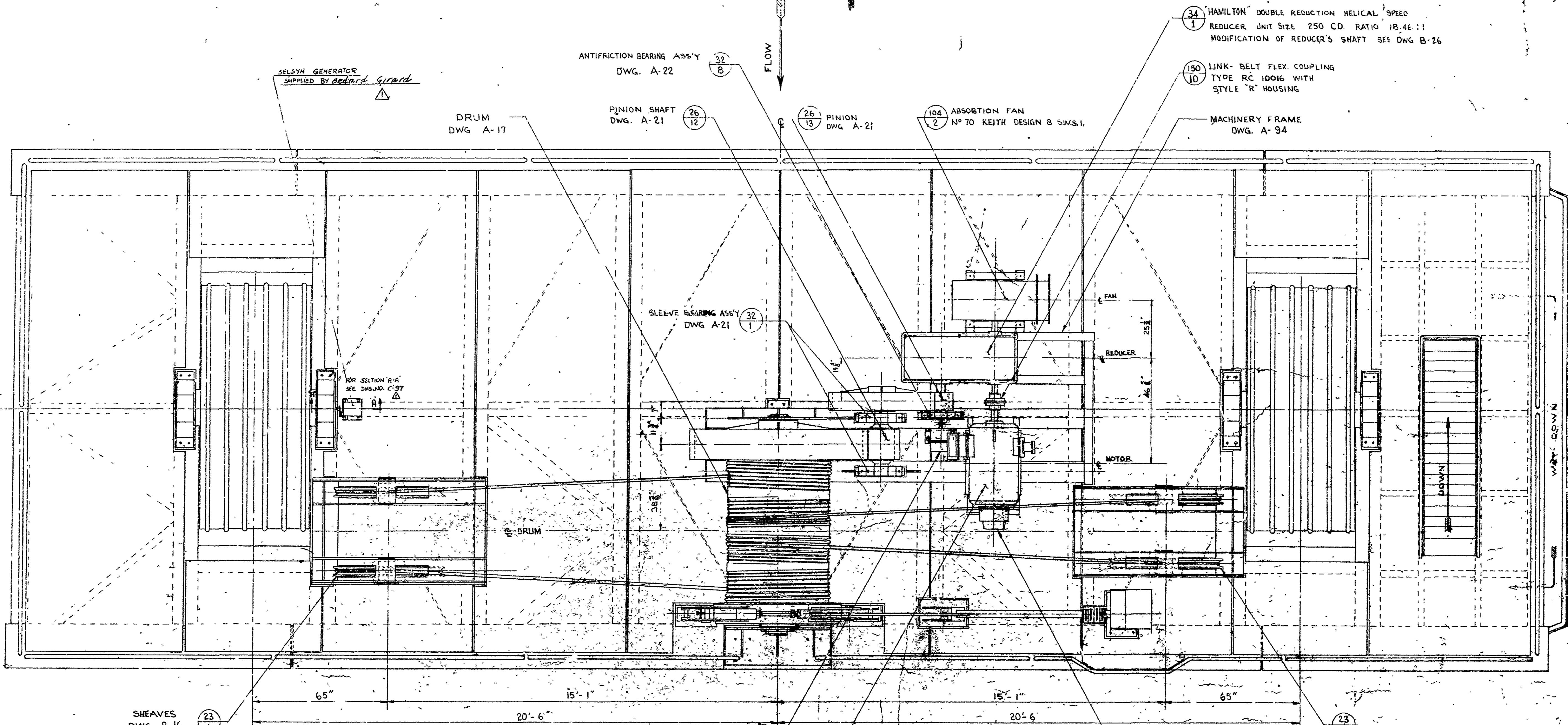

0-21-102-27  
STAIR, RAILING, 4 CHECK PLATE  
DWG. A-92

**RATED CAPACITY OF HOIST:**  
204' FOR CRACKING OF HOIST  
105' AT .8 FT/MIN.  
35' AT 30 FT/MIN.

THIS DRAWING AND ALL COPIES HEREOF, AS WELL AS ALL TECHNICAL INFORMATION APPEARING THEREON, ARE THE PROPERTY OF CANADIAN VICKERS LIMITED. NO PORTION, COPY, REPRODUCTION, OR USE IN ANY MANNER, WITHOUT THE WRITTEN PERMISSION OF CANADIAN VICKERS LIMITED, MAY BE MADE. THE USER SHALL BE RESPONSIBLE FOR OBTAINING ALL NECESSARY PERMITS AND APPROVALS FROM THE APPROPRIATE AUTHORITIES. THE USER SHALL BE RESPONSIBLE FOR OBTAINING ALL NECESSARY PERMITS AND APPROVALS FROM THE APPROPRIATE AUTHORITIES. THE USER SHALL BE RESPONSIBLE FOR OBTAINING ALL NECESSARY PERMITS AND APPROVALS FROM THE APPROPRIATE AUTHORITIES.

DESIGNED	DRAWN	CHECKED	SUBMITTED	APPROVED
BY: M. SPICER	TEP	WRC	SAP	
DATE: 12 FEB 62	14 FEB 62	14 FEB 62	14 FEB 62	

**CANADIAN VICKERS LIMITED**  
MONTREAL, CANADA  
INDUSTRIAL DIVISION

QUEBEC HYDRO ELECTRIC COMMISSION  
CARILLON DEVELOPMENT - NAVIGATION LOCK SECTION  
**ASSY OF HOISTING MACHINERY**

CONSULTING ENGINEER: THE SHAWINIGAN ENGINEERING CO. LTD.  
SCALE: 1" = 1 FT. DATE: 14 FEB 62  
CONTRACT NO. 21962 DRAWING NUMBER A-14

REV.	DATE	BY	REVISIONS
1	12 FEB 62	M. SPICER	DESIGN
2	14 FEB 62	WRC	CHECK
3	14 FEB 62	SAP	APPROV

**- NOTE -**  
The legibility of this drawing is substandard and may result in poor microfilm reproduction.



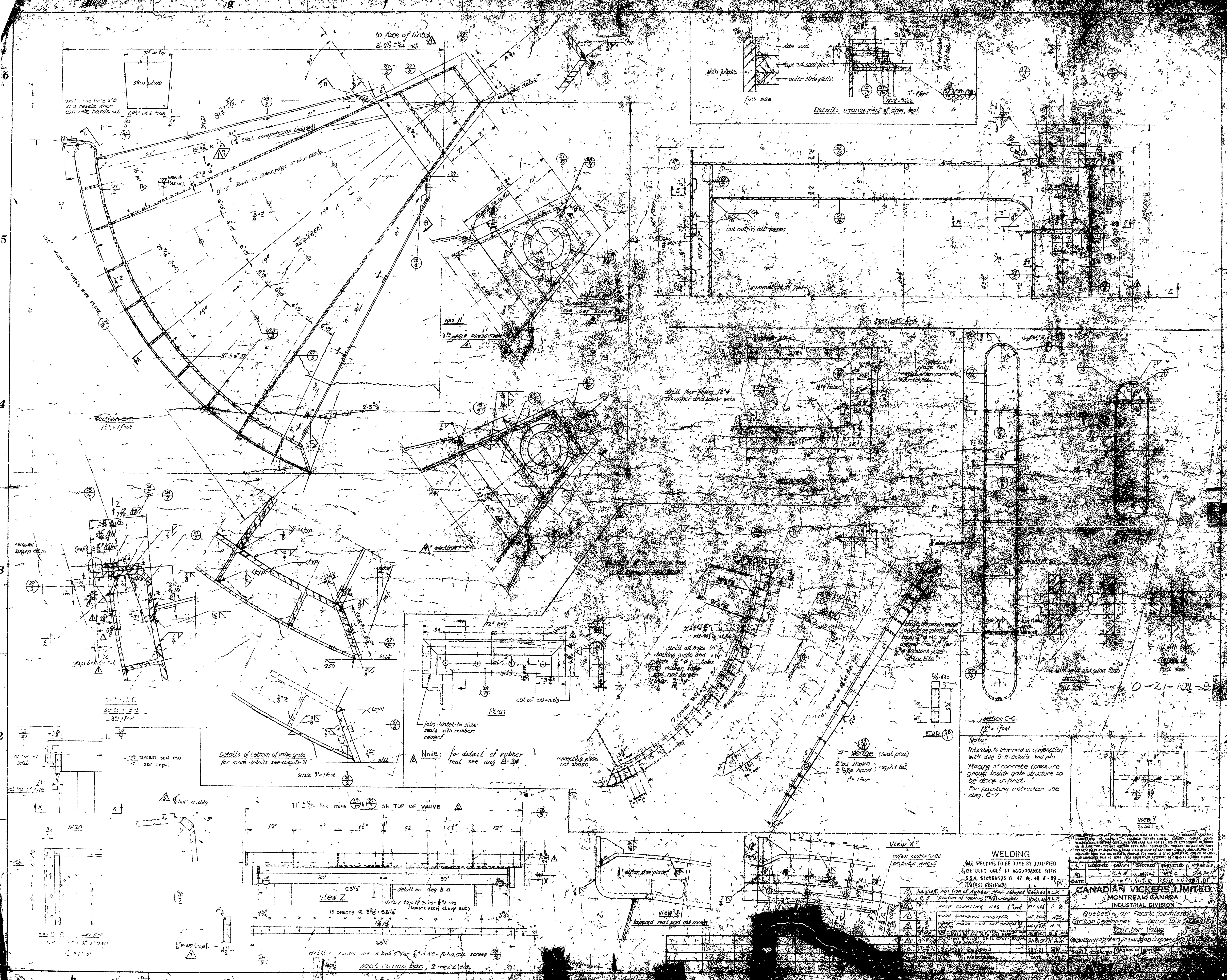

**Notes:**  
 This plan to be worked in conjunction with drawings B-31 details and pin  
 Raising of concrete (pressure groups) inside gate structure to be done in field.  
 For painting instruction see drawing C-7

**WELDING**

ALL WELDING TO BE DONE BY QUALIFIED WELDERS ONLY IN ACCORDANCE WITH C.S.A. STANDARDS W 47 W-48 W-59 (LATEST EDITIONS)

NO.	DESCRIPTION	DATE	BY	CHKD.
1	As per position of rubber seal changed	10/1/59	W.L.P.	
2	Position of openings changed	10/1/59	W.L.P.	
3	Weld coupling AWS 1" dia	10/1/59	W.L.P.	
4	Weld dimensions corrected	10/1/59	W.L.P.	
5	Welding AWS 1" dia	10/1/59	W.L.P.	
6	Welding AWS 1" dia	10/1/59	W.L.P.	
7	Welding AWS 1" dia	10/1/59	W.L.P.	
8	Welding AWS 1" dia	10/1/59	W.L.P.	
9	Welding AWS 1" dia	10/1/59	W.L.P.	
10	Welding AWS 1" dia	10/1/59	W.L.P.	

**CANADIAN VICKERS LIMITED**  
 MONTREAL, CANADA  
 INDUSTRIAL DIVISION  
 Quebec City, Air Electric Commission  
 Carillon Development, Montpelier, Que.  
 Counter Valve  
 Consulting Engineers, Montreal, Quebec

**- NOTE -**  
 The legibility of this drawing is substandard and may result in poor microfilm reproduction.







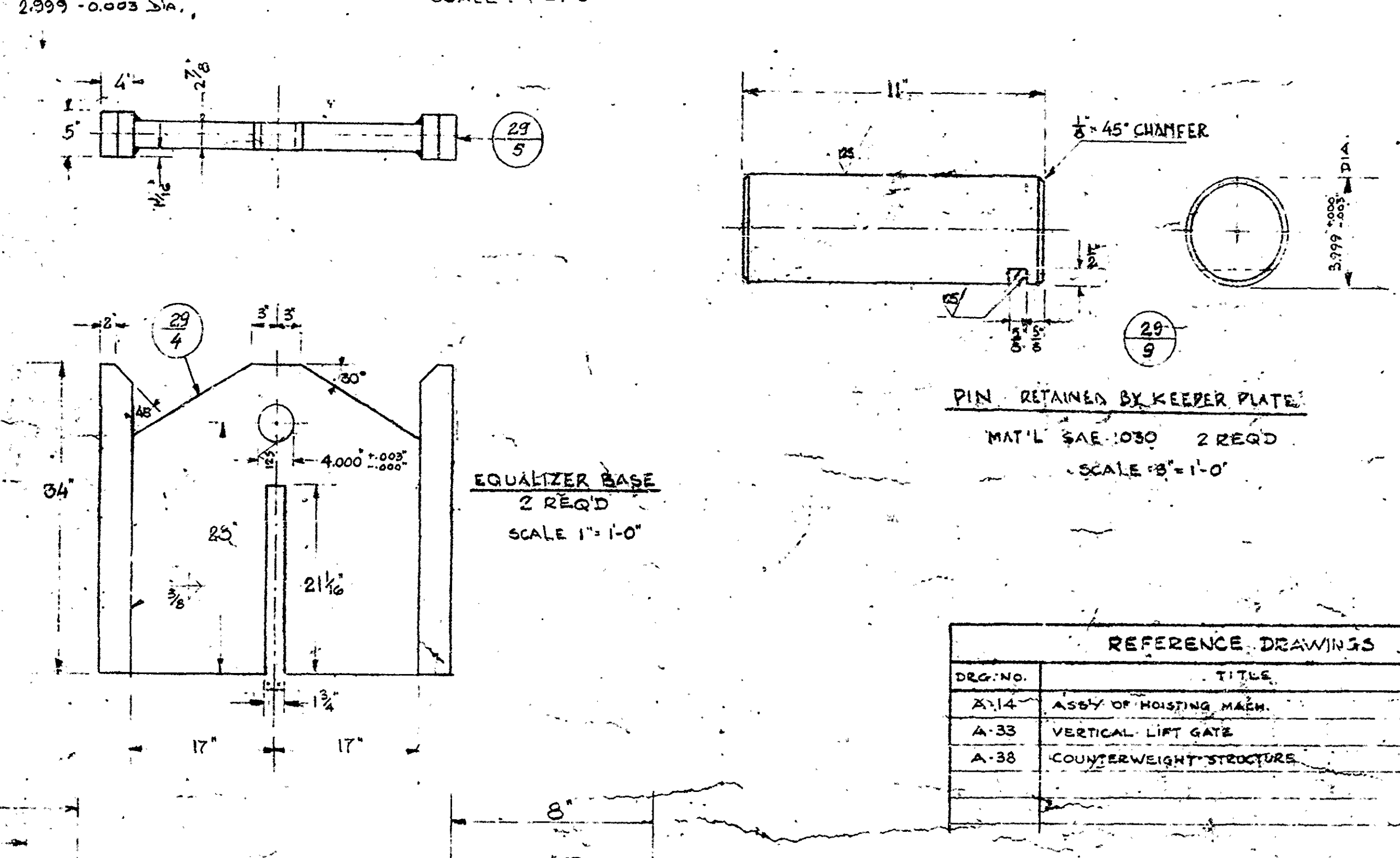
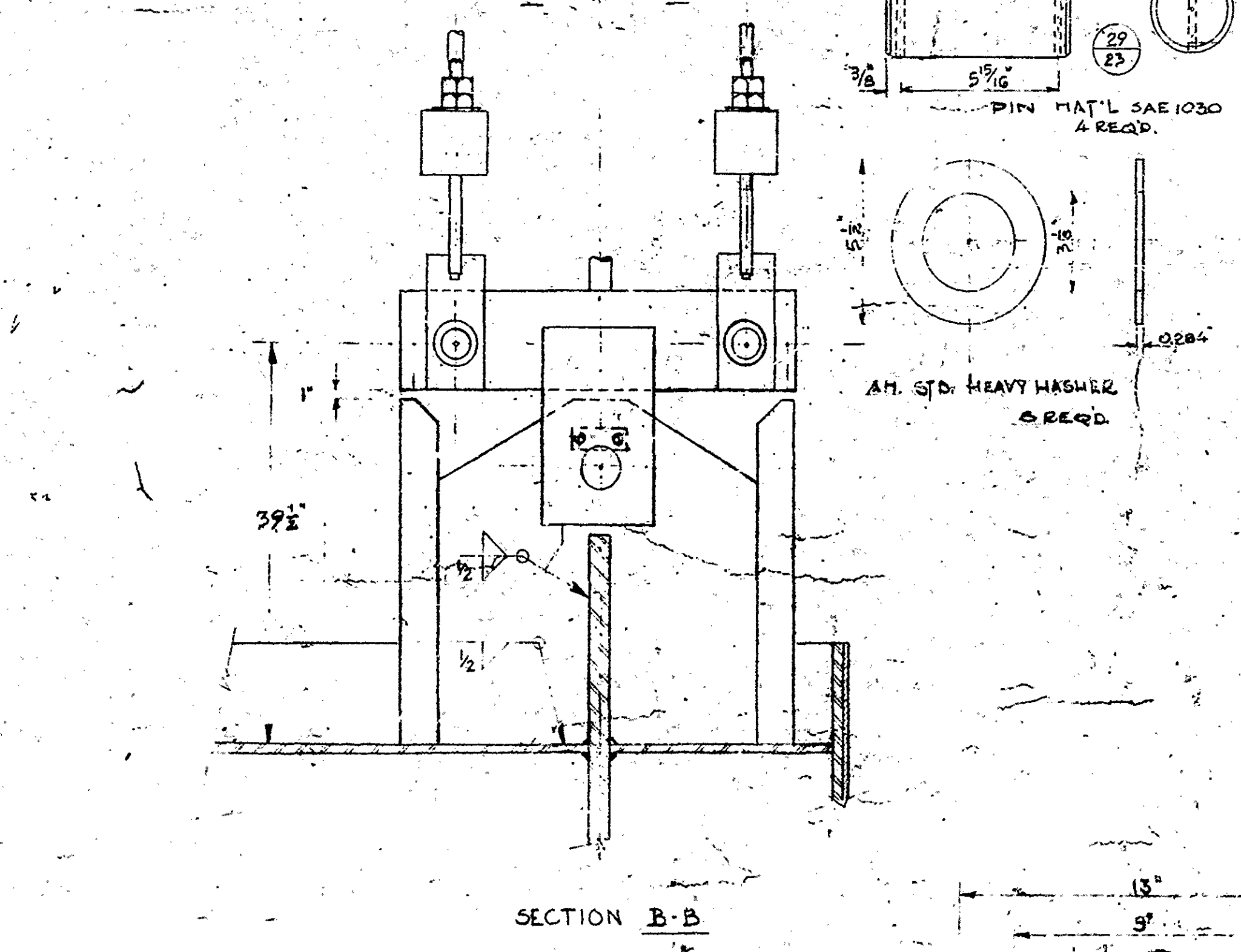
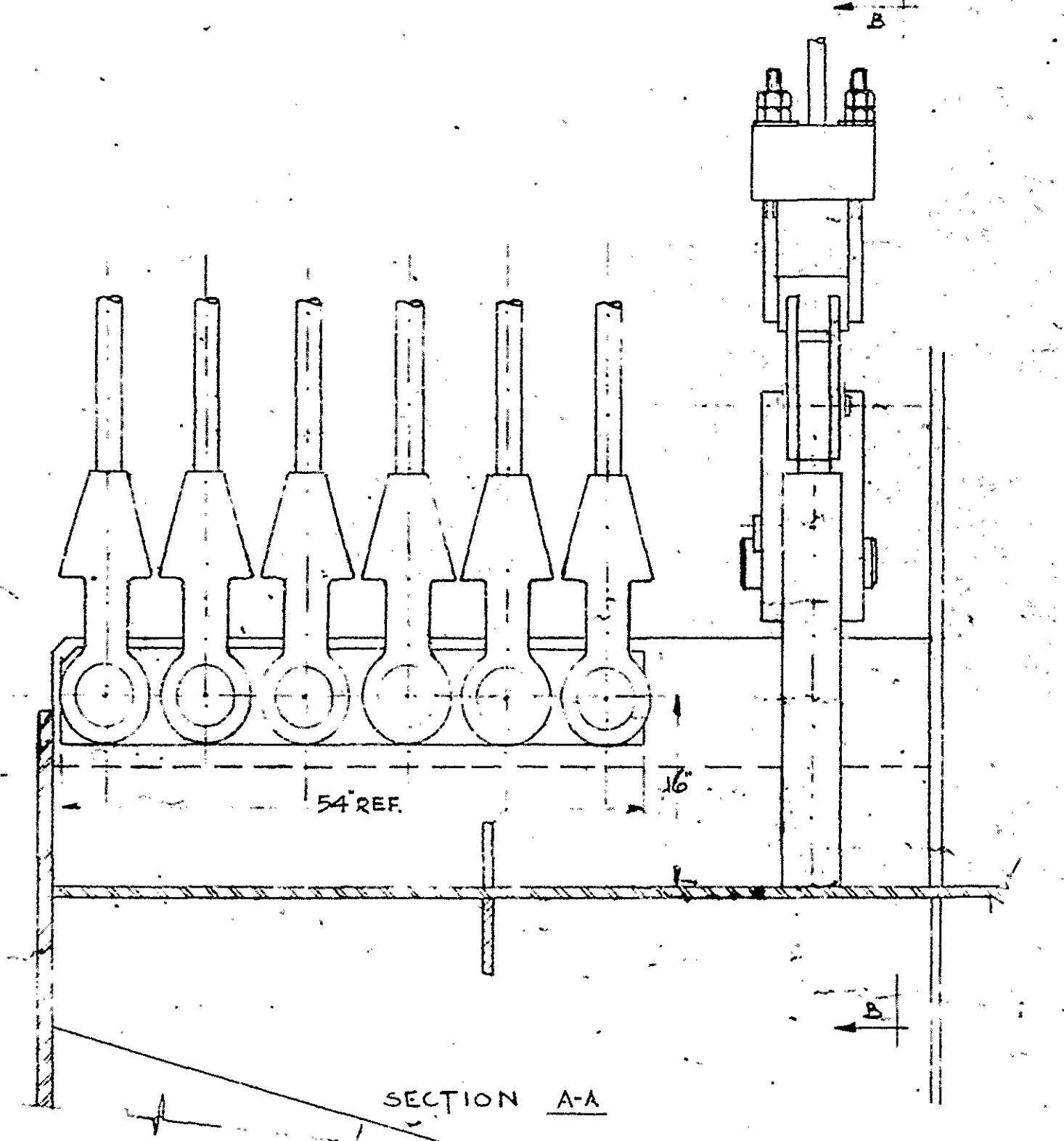
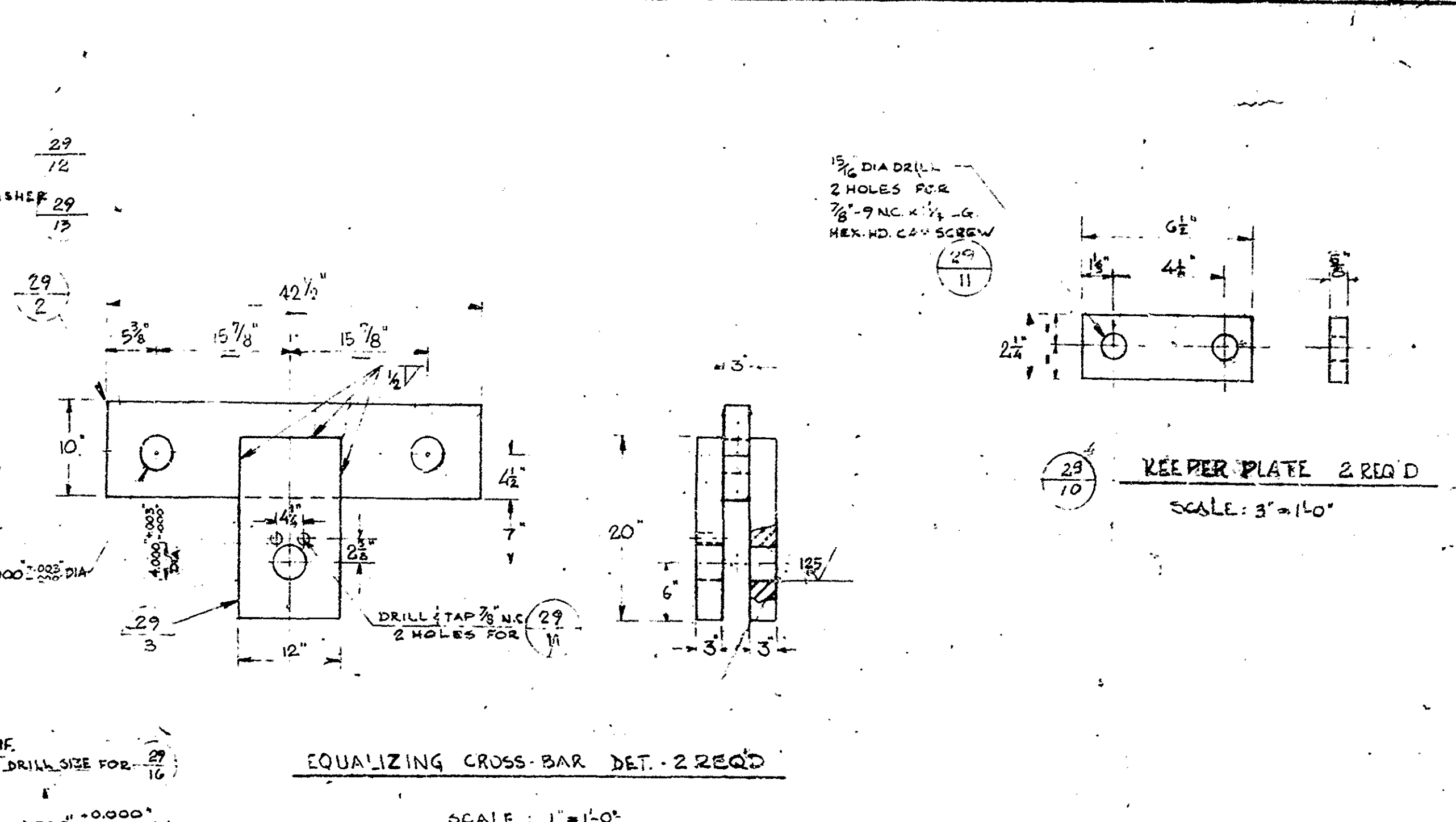
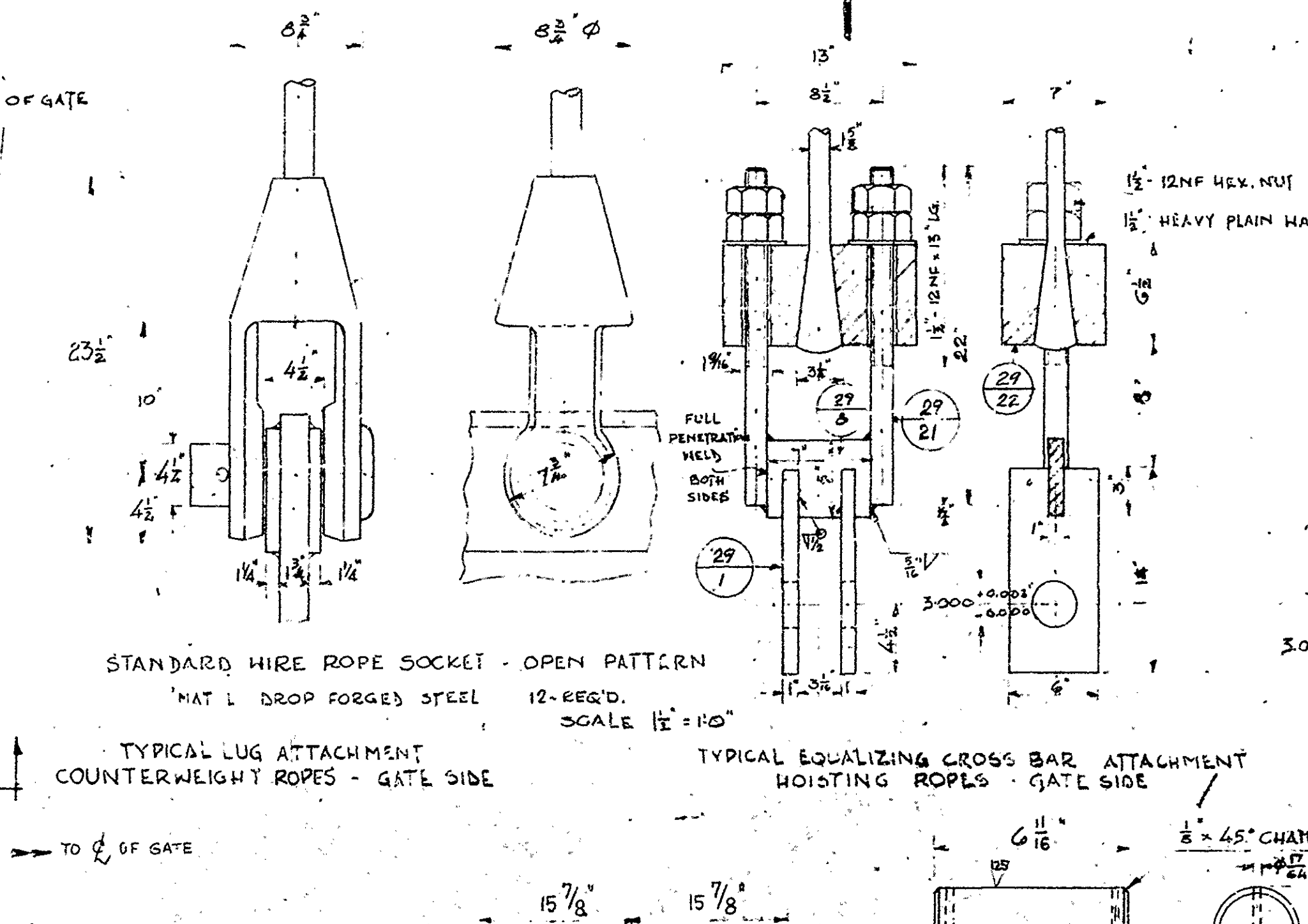
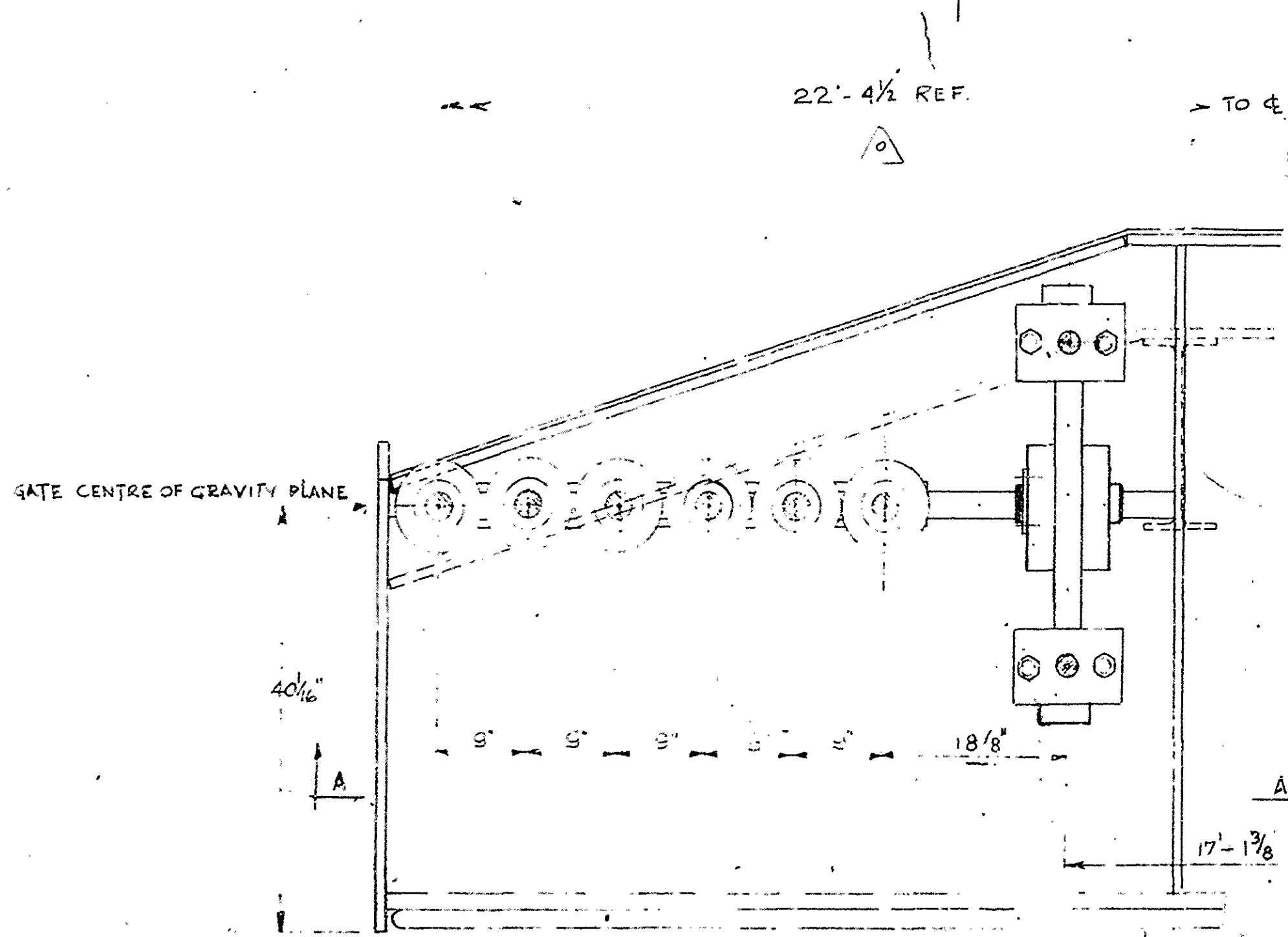

REFERENCE DRAWINGS	
DRG. NO.	TITLE
A-14	ASSEMBLY OF HOISTING MECH.
A-33	VERTICAL LIFT GATE
A-38	COUNTERWEIGHT STRUCTURE

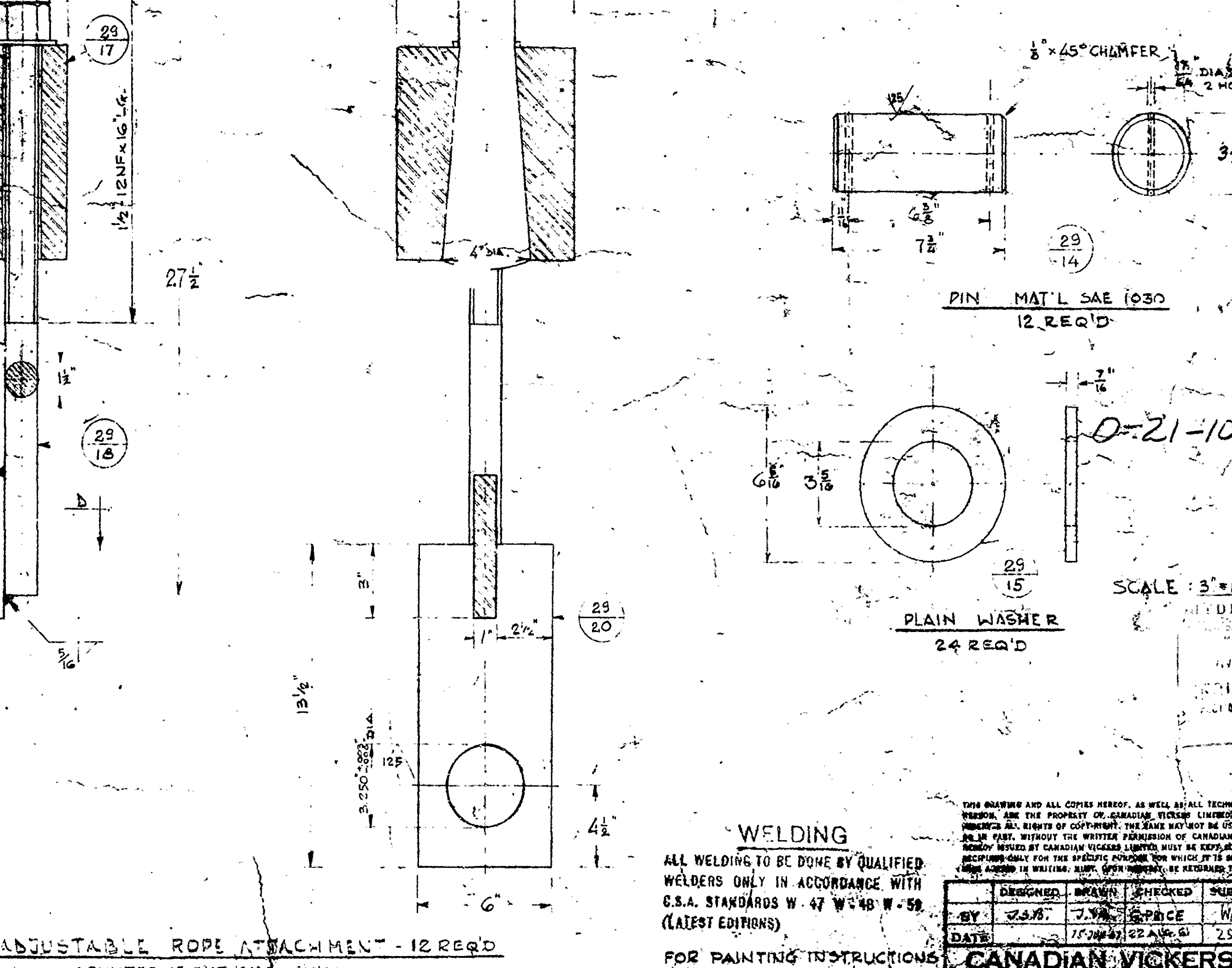
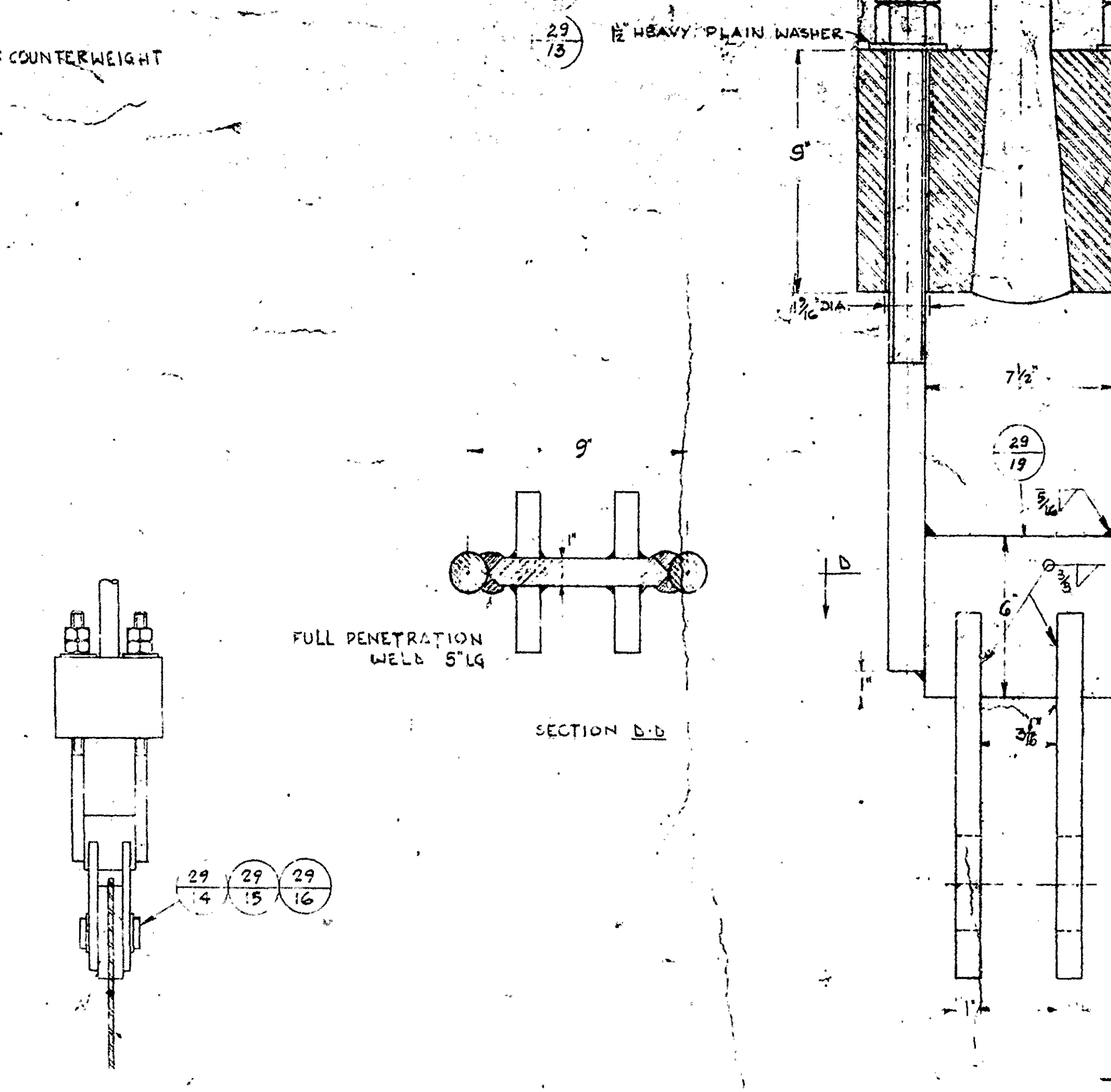
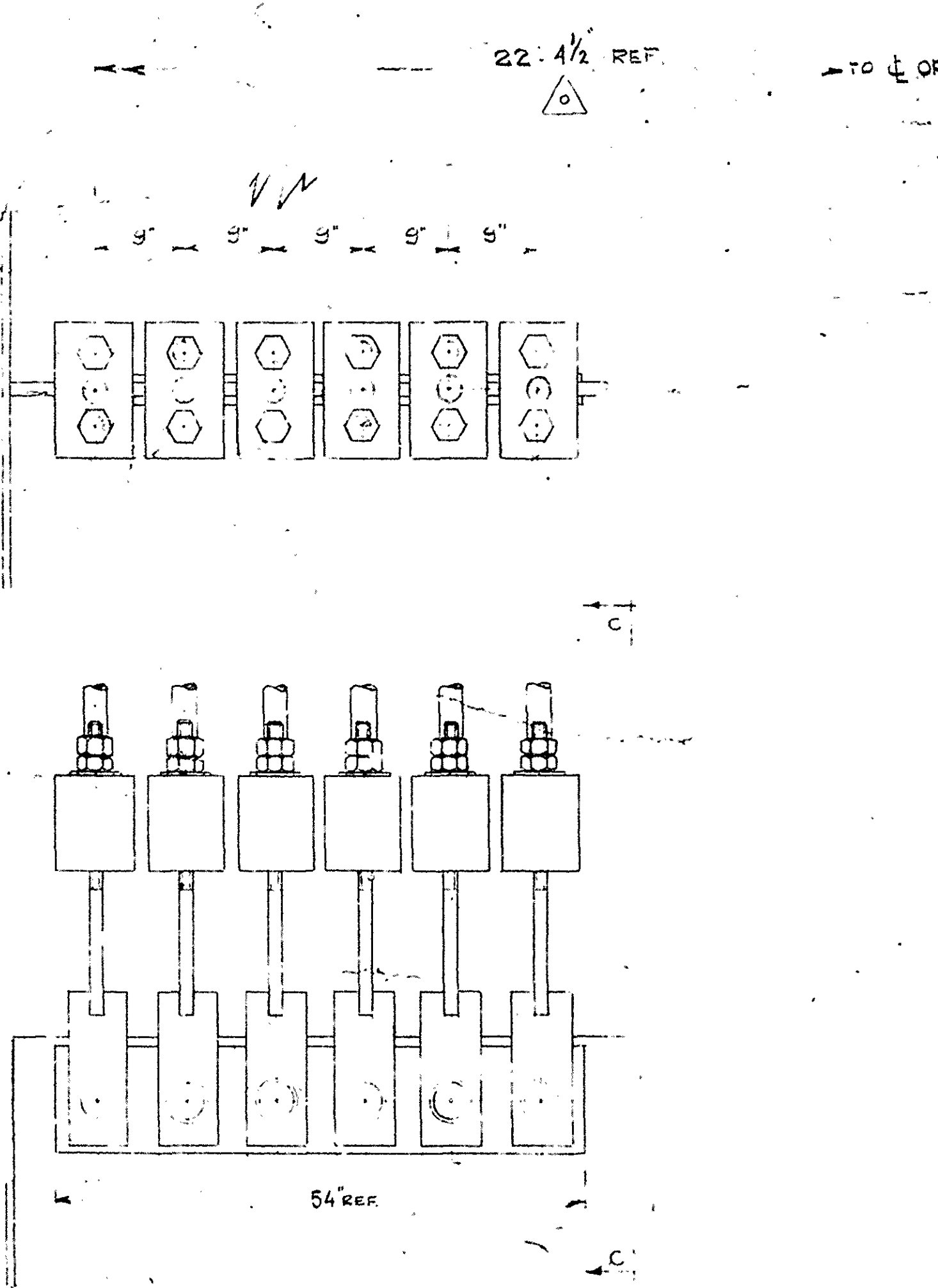

**WELDING**  
 ALL WELDING TO BE DONE BY QUALIFIED WELDERS ONLY IN ACCORDANCE WITH C.S.A. STANDARDS W-47 W-48 W-59 (LATEST EDITIONS)  
 FOR PAINTING INSTRUCTIONS SEE DRG. NO. C-7

DESIGNED BY: J.M.S. DATE: 7/20/52  
 DRAWN BY: J.M.S. DATE: 7/20/52  
 CHECKED BY: J.M.S. DATE: 7/20/52  
 APPROVED BY: J.M.S. DATE: 7/20/52

**CANADIAN VICKERS LIMITED**  
 INDUSTRIAL DIVISION  
 HYDRO-ELECTRIC DIVISION  
 CARILTON DEVELOPMENT CENTER  
 TORONTO, CANADA

**NOTE**  
 The legibility of this drawing is substandard and may result in poor microfilm reproduction.

**ANNEX B – VERTICAL GATE AND COUNTERWEIGHT  
STABILIZATION PROCEDURE**

# Vertical gate and counterweight stabilization procedure at the Carillon Navigation Lock

---

October 2016

Location:

Carillon Navigation Lock

Unité des voies navigables du Québec

UVNQ

*Resource contacts: Georges Giroux, Jade Castonguay, Brigitte Ayotte et  
Alain Gagnon*

# Vertical gate and counterweight stabilization procedure at the Carillon Navigation Lock

October 2016

Vertical gate approximate weight: 200 tons (400 000 lbs)

Vertical gate counterweight approximate weight: 180 tons (360 000 lbs)

- **Mandatory safety equipment**: safety glasses, glove, helmet and security patch.

- **Procedure specific equipment**: harness and fall-prevention device.

## Counterweight stabilization

### NB :

- Require two (2) cylinders, each having a minimal capacity of 100 tons to lift each counterweight. "H" Beams and steel shim (dimension to be confirmed).
  - Two (2) articulated and motorized platforms for simultaneous lifting operation to install the cylinders each side of the counterweight.
  - A crane with a basket for human lifting can also be used for this task.
- A) With the platform, move the lifting base (H beam) or the lifting table if already there. Put these lifting bases at the bottom of the counterweight slide under it and perform the leveling of these bases.  
(Photos 9, 10 and 11)
- B) Install cylinder on the center of the lifting base.  
Note: have shim in sufficient quantity and dimension for the required lifting height.

### **IMPORTANT**

For additional safety, a retainer shall also be installed on the counterweight linked to both side of the counterweight slide (photo 14) to prevent movement of the counterweight caused by strong wind of other events (mouvement amont/aval).

NB : the wood «WEDGE» installed each side of the counterweight also help avoiding any shifting.

# Vertical gate and counterweight stabilization procedure at the Carillon Navigation Lock

---

October 2016

- C) Start the lifting (simultaneously) with the cylinders (min. 100 tons) and place the shims each side of the cylinders to fill any possible void.
- D) Perform the lifting operation until there is no charge remains on the cable, or only their own residual weight.
- E) Remove cylinders after stabilization.



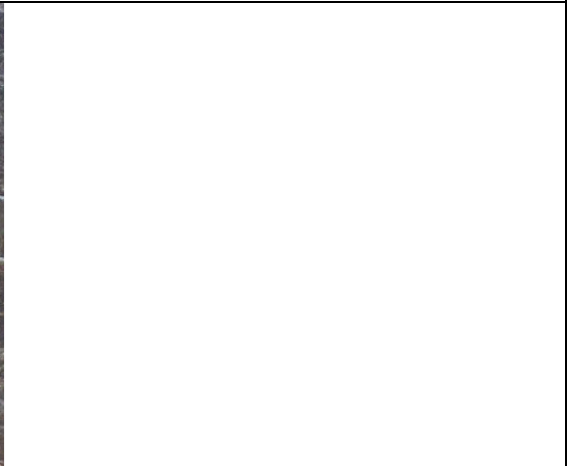





2013/11/04

**ANNEX C – MITIGATION AND SIGNIFICANCE OF RESIDUAL  
EFFECTS**



Annex C Mitigation and significance of residual effects – CCRL 1401

Project Component or Activity	Environmental Component	Description of Environmental Effects	Impact Mitigation Measures	Significance of Residual Effects
<p>1. Use and movement of machinery/ Transportation of materials and equipment/ Storage</p> <p>Job site set-up/ Demobilization</p>	Air quality and public health	<ul style="list-style-type: none"> <li>Decrease in ambient air quality from particle emissions (dust)</li> <li>CO<sub>2</sub> emissions from machinery</li> </ul>	<p>1.1 Ensure that exhaust and anti-pollution systems on construction machinery/equipment are kept in good working order.</p> <p>1.2 Shut off vehicles when not in use.</p> <p>1.3 Comply with current municipal bylaws regarding dust emissions in the air.</p> <p>1.4 Ensure that fine materials used for construction and residues are contained during transportation.</p> <p>1.5 Where needed, cover with a sheet stockpiled fine materials that could be carried away by the wind.</p> <p>1.6 Avoid handling and moving materials that can erode easily in high winds or when a plume of dust is visible.</p> <p>1.7 Comply with current municipal bylaws regarding noise and work hours.</p> <p>1.8 Manage the job site in a way that minimizes work that generates significant noise.</p>	Residual impact negligible and localized
	Noise levels	<ul style="list-style-type: none"> <li>Increase in surrounding noise levels</li> </ul>	<p>1.9 Keep construction equipment and machinery in good working order and do regular servicing throughout the work. Repair vehicles or equipment with leaks immediately or remove them from the site.</p> <p>1.10 Store, handle and use petroleum products with care and have containment and recovery materials on hand (e.g.: absorbent materials) in the event of leaks or spills.</p> <p>1.11 Establish an emergency procedure and a communication protocol in the event of an environmental incident.</p> <p>1.12 In the event of a spill, report the situation immediately to the appropriate stakeholders and the Environment Canada emergency service (1-866-283-2323) for a land spill.</p> <p>1.13 Do not store fuels, oils, lubricants or other petrochemicals less than 30 metres from the water body and place them on waterproof sheets.</p> <p>1.14 Avoid refueling machinery less than 30 metres from the water body.</p> <p>1.15 Implement sediment and erosion control measures if the soil is disturbed or exposed.</p> <p>1.16 Avoid vehicle movements during heavy rain or when soil is saturated with water.</p> <p>1.17 Where needed, cover topsoil quickly with peat or a sheet in the event of rain.</p> <p>1.18 Machinery may not operate in the canal bed at any time.</p>	Nil once the work is complete
	Water and soil/sediment quality	<ul style="list-style-type: none"> <li>Compaction of soil in the mobilization zone (where applicable)</li> <li>Risk of spill of hydrocarbons or other harmful substances into the soil/sediment or water</li> </ul>	<p>1.21 Establish and mark a protective area around trees and shrubs to be kept (e.g.: tape, barriers, etc.) to prevent damage to them or their root systems.</p> <p>1.22 Restore damaged soil surfaces and vegetation to return the site to the condition it was in prior to the work.</p> <p>1.23 Restored surfaces should have the same degree of compaction and aeration as initially (prior to the work) to prevent soil particle transportation and movement.</p> <p>1.24 Where necessary, trees and shrubs to be cut down shall be replaced during the restoration phase upon completion of the work.</p> <p>1.25 Satisfy any other requirement of the project manager and job site supervisor.</p> <p>1.26 Ensure that machinery is clean and free of invasive species or harmful weeds upon arrival on site and subsequently maintain them in that state. Upon completion of the work, clean machinery that has come into contact with non-native invasive species to prevent spreading them to new areas.</p>	Residual impact negligible and localized
<p>2. Concrete demolition (sawing, crushing, etc.)</p>	Terrestrial flora	<ul style="list-style-type: none"> <li>Damage to vegetation, grassy areas in the sector</li> <li>Damage to root systems, branches and bark due to machinery movement</li> </ul>	<p>2.1 Measures 1.3 to 1.5</p> <p>2.2 Employ work methods that generate as little dust as possible.</p> <p>2.3 Comply with current regulations during demolition work.</p>	Residual impact negligible and localized
	Air quality and public health	<ul style="list-style-type: none"> <li>Decrease in ambient air quality from particle emissions (dust)</li> </ul>	<p>2.4 Measures 1.7 and 1.8</p> <p>2.5 Plan measures to contain and recover debris (e.g.: tarp, geotextile, sediment barrier ballasted or affixed parallel to the bank). Take care to limit displacement of residue in the water body when removing equipment.</p>	Residual impact negligible and localized
Removal, storage and	Noise levels	<ul style="list-style-type: none"> <li>Increase in ambient noise levels</li> </ul>		Nil once the work is complete
	Water and soil/sediment quality	<ul style="list-style-type: none"> <li>Increase in suspended solids and particles in the canal</li> </ul>		Residual impact negligible and localized

Annex C Mitigation and significance of residual effects – CCRL 1401

Project Component or Activity	Environmental Component	Description of Environmental Effects	Impact Mitigation Measures	Significance of Residual Effects
disposal of wall debris		<ul style="list-style-type: none"> <li>• Friable concrete debris that has contacted contaminated soil could be deposited on the ground or in the canal bed during the work.</li> </ul>	<p>2.6 Clean up debris as work progresses and dispose of at sites authorized by the MDDELCC.</p> <p>2.7 Do not release debris or residue into the water body.</p> <p>2.8 Do not take borrow materials from the water body.</p>	Residual impact negligible and localized
3. Cleaning of surfaces (sand and pressurized water blasting)	Air, soil and water/sediment quality, aquatic resources and human health	<ul style="list-style-type: none"> <li>• Release of contaminated substances into the environment</li> <li>• Emission of dust and particles containing silica into the air</li> <li>• Poisoning of workers exposed to silica particles</li> </ul>	<p>2.9 Do not encroach on the water body in order to prevent loss of fish habitat.</p> <p>3.1 Measure 1.3</p> <p>3.2 Introduce adequate recovery and containment measures to minimize release of contaminants into the air and soil, e.g.:</p> <ul style="list-style-type: none"> <li>- Install a shelter and a tarp to hold sandblast particles and concrete residue generated by the cleaning work. The shelter must be waterproof to prevent leaching in event of rain and have a mechanism for capturing soil and preventing discharge into the canal.</li> </ul> <p>3.3 Treat sandblast residue as residual hazardous materials (RHM), as stipulated in the <i>Regulation respecting hazardous materials</i>. Introduce adequate measures to:</p> <ul style="list-style-type: none"> <li>- Recover all sandblast residue</li> <li>- Store residue in a sealed fashion</li> <li>- Dispose of residue at sites authorized by the MDDELCC</li> </ul> <p>3.4 Comply with allowable levels of silica in the abrasive, as specified in the regulations in force.</p> <p>3.5 To the extent possible, use an abrasive with a less significant impact than silica.</p> <p>3.6 Use the required protective gear (mask, gloves, etc.) in accordance with exposure values.</p> <p>3.7 Work during periods of less significant natural activity (breeding, feeding, etc.).</p> <p>3.8 Measure 5.2</p>	Residual impact negligible and localized
4. Repairs to walls (concrete pouring and/or shotcrete)	Water and soil/sediment quality, aquatic resources	<ul style="list-style-type: none"> <li>• Introduction of materials</li> <li>• Contamination and loss of habitat</li> <li>• Products used can alter local natural components of the aquatic environment</li> </ul>	<p>4.1 Measures 2.5 to 2.8</p> <p>4.2 Use products with fewer adverse effects on the environment and ensure environmental compliance.</p>	Residual impact negligible and localized
5. Excavation/backfilling	Water and soil/sediment quality, aquatic resources and human health	<ul style="list-style-type: none"> <li>• Contamination of soil through cross contamination</li> <li>• Erosion and release of contaminated sediment into the aquatic environment</li> <li>• Contamination of fill by nearby soil</li> </ul>	<p>5.1 Present a plan for managing contaminated soil to the Departmental Representative for approval before undertaking excavation work.</p> <p>5.2 Manage excavated soil in accordance with applicable federal, provincial and municipal legislation governing management of contaminated soil.</p> <p>5.3 Avoid undertaking excavation work during heavy rain or high winds.</p> <p>5.4 Limit in situ storage time for excavated materials.</p> <p>5.5 When storing contaminated soil temporarily, take the necessary precautions to prevent contamination of underlying and adjacent soil, by doing the following at a minimum:</p> <ul style="list-style-type: none"> <li>- Separate soils according to level of contamination and observed stratigraphy.</li> <li>- Store soils on a waterproof sheet and cover them, or store them in another type of sealed container. Anchor covers securely to prevent them flapping in the wind.</li> <li>- Ensure that soil does not migrate into other environments via the air, runoff or vehicle movement.</li> </ul> <p>5.6 Replace soil as quickly as possible depending on the initial contamination levels found and the initial stratigraphic profile.</p> <p>5.7 Where needed, carry out a characterization of the surplus excavated soil to determine degree of contamination and manage disposal properly.</p> <p>5.8 When disposing of soil off-site, keep and forward to the Departmental Representative any document or slip showing that it was disposed of at a site authorized by the MDDELCC for the degree of contamination.</p> <p>5.9 Where surface soil requires remediation, install a geotextile membrane between contaminated soil in place</p>	Residual impact negligible and localized

Annex C Mitigation and significance of residual effects – CCRL 1401

Project Component or Activity	Environmental Component	Description of Environmental Effects	Impact Mitigation Measures	Significance of Residual Effects
			<p>and new material.</p> <p>5.10 Where replaced soil exceeds current CCME guidelines for residential/parkland use (equivalent of MDDELCC criteria B), cover with at least 30 cm of clean soil.</p> <p>5.11 Any soil imported onto Parks Canada property must be arable soil that meets the latest City of Montreal and Bureau de Normalisation du Québec standards.</p> <p>5.12 Use clean fill material that is free of contaminants and undesirable species.</p> <p>5.13 New material (e.g.: topsoil, controlled fill) must be properly compacted to prevent any subsidence, minimize erosion and foster revegetation.</p> <p>5.14 Comply with all specific requirements set by Parks Canada as regards archeological monitoring.</p> <p>5.15 Where archeological monitoring is not required for the work and archeological remains (remnants of buildings or developments, objects or fragments of objects) are discovered by chance during the excavations, suspend work in the immediate area of the discovery and notify the Parks Canada representative, who will take the necessary steps to protect and preserve the archeological remains.</p> <p>5.16 Introduce effective measures to limit discharge of sediment from the job site into the aquatic environment and maintain them properly (e.g.: sediment barrier, berms, sediment trap, settling basin, temporary slope stabilization, diversion of water to areas of vegetation). Measures must remain effective during temporary closure of the job site and during periods of high water or heavy rain.</p> <p>5.17 Ensure that residual water from the work is recovered and contained. If a treatment system (portable settling basin, filters or similar equipment) must be used, it must prevent contaminants and particles that are likely to settle from running into the sewers. Take necessary steps to identify a method of removing captured sediment and residual water and to comply with applicable discharge standards.</p> <p>5.18 In the event of a discovery of cultural resources (e.g.: archeological), suspend work immediately and notify the Departmental Representative.</p> <p>6 Restore soil surfaces and vegetation damaged by the work and movement of machinery to leave the site as it was prior to the work.</p>	
6. Tree cutting	Terrestrial flora and fauna	<ul style="list-style-type: none"> <li>• Damage to vegetation</li> <li>• Loss of habitat for wildlife</li> <li>• Damage to nests and/or disturbance of nesting animals</li> </ul>	<p>7.1 Limit cutting/pruning to the minimum necessary in order to preserve plant cover to the extent possible.</p> <p>7.2 Restore and replant the site upon completion of the work. This includes re-establishing the plant cover in areas approved in advance by Parks Canada using various rapid-growth indigenous species that require little maintenance and are suitable for the project zone in order to enhance the local plant community.</p> <p>7.3 Determine presence of nests or dens in the area before proceeding with pruning to prevent disturbance of occupied nests or dens.</p> <p>7.4 Where there are nests, proceed with cutting outside of the nesting season for migratory birds that use the region. The regional period established for the St. Lawrence plains by Environment Canada extends from early April to late August.</p> <p>7.5 Branches and tree trunks must be cut short, as close to the ground or trunk as possible.</p> <p>7.6 Trunks and other materials recovered must be taken to a storage site without spreading debris or damaging standing trees or elements of the landscape outside the boundaries indicated for cutting or storage. Do not drag through the water body.</p> <p>7.7 If stumps, roots embedded trunks or other non-woody debris must be dug out, remove and shake them to free them of soil and loose rocks before transporting them to the designated site.</p> <p>7.8 Vegetation debris must be removed as quickly as possible from the right of way and taken off-site for disposal.</p> <p>7.9 Store removed vegetation in areas already subject to disruption to minimize the area of disturbance.</p>	Residual impact negligible and localized

Annex C Mitigation and significance of residual effects – CCRL 1401

Project Component or Activity	Environmental Component	Description of Environmental Effects	Impact Mitigation Measures	Significance of Residual Effects
			<p>7.10 Comply with City of Montreal regulations regarding ash trees. If ash trees are felled between March 15 and October 1, they must be processed on site following the proper procedure. Between October 1 and March 15, ash tree residue can be disposed of at a processing site.</p> <p>7.11 Do not use pesticide near water (within 3 metres of the high water line). If pesticides are required elsewhere on the work site, a pesticide treatment plan must be submitted for approval via the Parks Canada process.</p>	
<p>7. Disposal of waste (construction/demolition materials, cleaning water, etc.)</p>	<p>Air, soil, water/sediment quality, aquatic resources and human health</p>	<ul style="list-style-type: none"> <li>• Introduction of construction and demolition waste</li> <li>• Introduction of contaminants through cleaning residue</li> <li>• Deterioration of soil quality</li> </ul>	<p>8.1 Ensure that residual water and cleaning water is contained and recovered. If a treatment system (portable settling basin, filters or similar equipment) must be used, it must prevent contaminants and sediment from running to the sewers and bodies of water. Take the necessary steps to identify the method of disposing of captured sediment, residual water and comply with applicable discharge standards.</p> <p>8.2 Dispose of all non-hazardous residual materials off site and provide sufficient containers to store domestic waste on a daily basis.</p> <p>8.3 Introduce an adequate management program to ensure that waste is contained and disposed of, including metal waste, used asphalt paving and concrete debris. To the extent possible, isolate the waste at source and recycle.</p> <p>8.4 Do not store hazardous waste on site and remove from site in accordance with applicable regulations.</p>	<p>Residual impact negligible and localized</p>

**ANNEX D – TECHNICAL SPECIFICATION**

POSITION OF DISCHARGE & ROTATION FROM DRIVE SIDE							
BH	CW	BAU	CW	UB	CW	TAU	CW
FIG.1	FIG.2	FIG.3	FIG.4	FIG.5	FIG.6	FIG.7	FIG.8
TH	CW	TAD	CW	BH	CCW	TAU	CCW
FIG.9	FIG.10	FIG.11	FIG.12	FIG.13	FIG.14	FIG.15	FIG.16
UB	CCW	TAU	CCW	TH	CCW	TAD	CCW

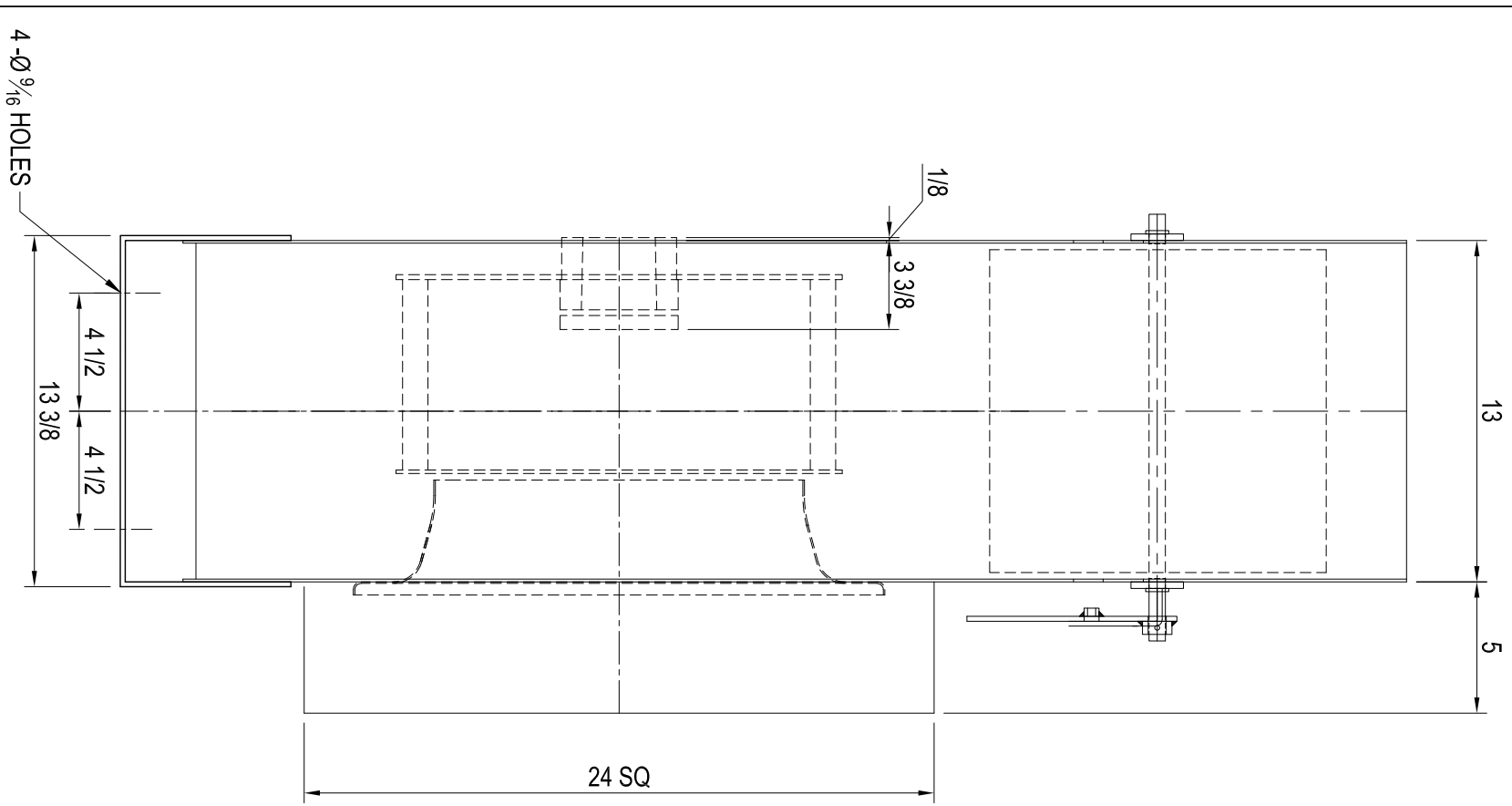
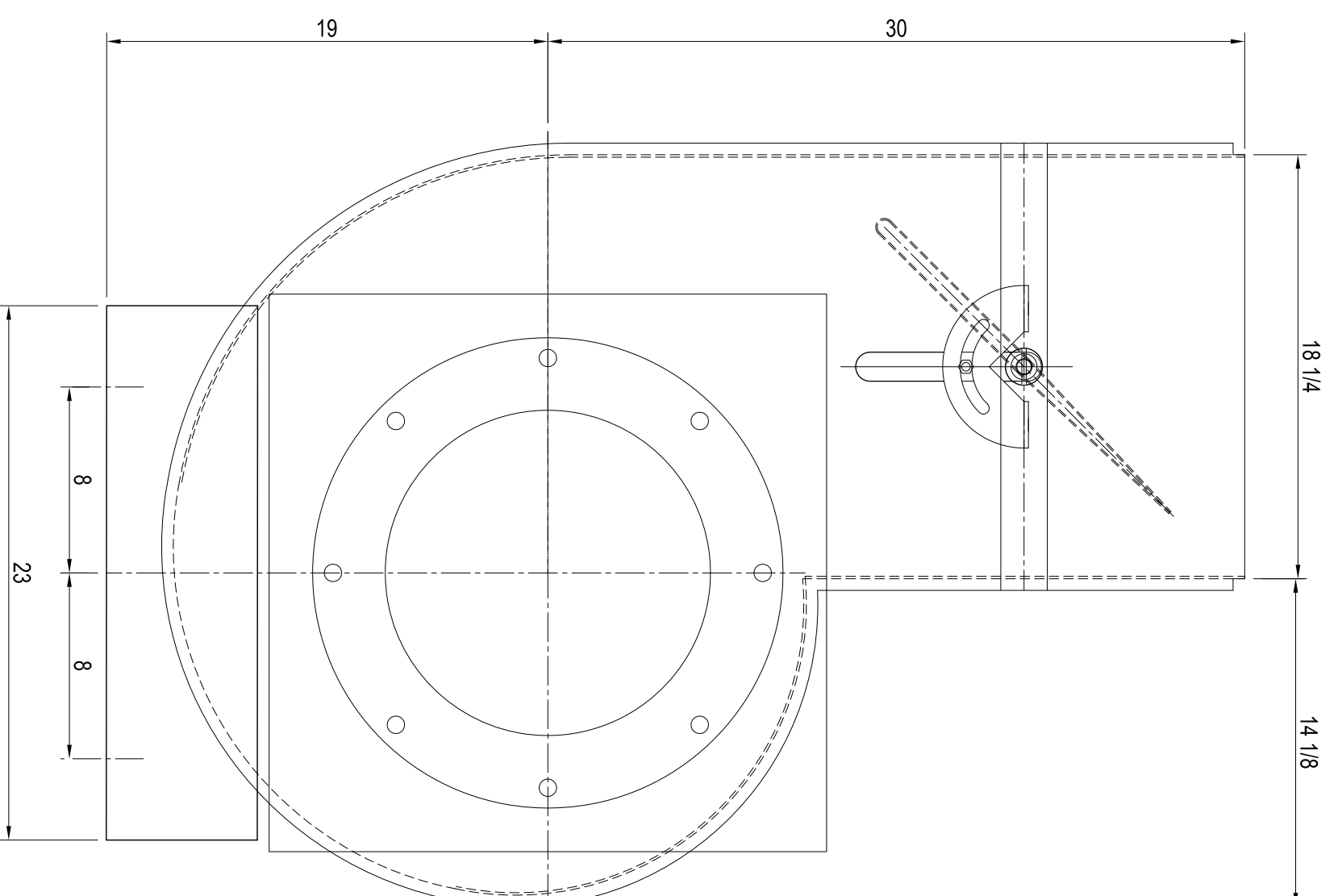

REV: 1	INT: 8/30/11	DESC: WAS UB	CHKD:	DRAWN:
SCALE: NTS	DATE:			

DWG NO: CD-1316

REV:

TITLE: FAN ASSEMBLY

1316 FC PA A4 C5

SHELDONS ENGINEERING INC  
 6660 ORDAN DRIVE, MISSISSAUGA ONTARIO, L7T 1J7  
 (905) 564-5072 \* FAX: (905) 564-9004 \* WWW.SHELDONSENGINEERING.COM



LESON

1000

1000





# LEESON<sup>®</sup>



MEETS NEMA MG1, PART 30 & 31

CAT. NO. C180897

152252

MODEL

FRAME 3641C

DESIGN B

THREE PHASE

DUTY CONT

ENCL. THERC

DATE A16

MAX. AMB. 40 °C

INS. CL. 15

SER.# HAV05372

H.P. 40

VOLT. 575

LOAD TYPE

CODE G

AMPS. 405

INVERTER TYPE

S.F. 115

R.P.M. 1192

SPEED RANGE

NOM. EFF. 94%

P.F. 78.5 S.F.A. 40

HZ 60

MADE IN CHINA REF#17023806

TYPE

L1-T1

T6

DELTA RUN

L1-T1-T6

P.E. BRG. 307

L2-T2

T4

DELTA RUN

L2-T2-T4

O.P.E. BRG. 634

L3-T3

T5

DELTA RUN

L3-T3-T5

WGT. 100700

REGAL BELOIT CANADA  
MISSISSAUGA, ONTARIO L5T 2N7





# LEESON®



152252

MEETS NEMA MG1. PART 30 & 31

DESIGN B THREE PHASE

CAT. NO. CH0807

FRAME 36ATC

DATE 4/16

MODEL

ENCL. THC

SER.# HANCOCK

DUTY CONT

INS. CL. B5

MAX. AMB. 100 °C.

H.P. 405

VOLT. 575

CODE 405

AMPS. 405

S.F. 116

R.P.M. 1192

NOM. EFF. 941

P.F. 785

S.F.A.

HZ 60

SPEED RANGE

TYPE TE

TRADE IN CHINA. REF# 1025800

P.E. BRG.

O.P.E. BRG.

WGT. 100700

WYE START	L1-T1	L2-T2	L3-T3
	T6	T4	T5

DELTA RUN	L1-T1-T6	L2-T2-T4	L3-T3-T5
-----------	----------	----------	----------

REGAL BELOIT CANADA  
MISSISSAUGA, ONTARIO L5T 2N7





MEETS NEMA MG1. PART 30 & 31

# LEESON®



1000700

CAT. NO.	0180397	FRAME	30-11C	DESIGN	B	THREE PHASE
MODEL		ENCL.	TEFC	DATE	A16	
DUTY	CONT.	MAX. AMB.	40 °C	SER.#	HAJ005372	
H.P.	10	VOLT.	575	LOAD TYPE		
CODE	G	AMPS.	405	INVERTER TYPE		
S.F.	115	R.P.M.	1192	SPEED RANGE		
NOM. EFF.	94	P.F.	785	HZ	60	
		S.F.A.	46	TYPE	IT	
MADE IN CHINA. REF#110938.00						
WYE START	L1-T1	L2-T2	L3-T3	P.E. BRG.	6311	
	T6	T4	T5	O.P.E. BRG.	6314	
DELTA RUN	L1-T1-T6	L2-T2-T4	L3-T3-T5	WGT.	850 LBS	100700

REGAL BELOIT CANADA  
MISSISSAUGA, ONTARIO L5T 2N7

Project

Project1

## User data

Type of driving machine		AC-motor
Operating hours/day [h]	[h]	>10
Operating cycle / hour ED [%]	[%]	100
Altitude [m above MSL]	[m]	0...< 1000
Installation site		Large rooms and halls
Ambient conditions		dry
Ambient temp. (min/max) [°C]	[°C]	-25/30

## Operating data

Motor power, nominal PM [kW]	[kW]	29.8
Input speed [r/min]	[1/min]	1200
Operating power PK1 [kW]	[kW]	29.8
Output power PK2	[kW]	29
Input torque MK1	[Nm]	235
Output torque MK2	[Nm]	4630
Start mode		Direct
Number of peak loads		1 - 5
Max. peak load torque MK2 max	[Nm]	0
Reversing operation		No

## Gear unit data

Catalog designation		X3FS120 /HU /B
Housing machining		Universal
Input speed [r/min]	[1/min]	1200
Ratio		20.26
Output speed n2	[1/min]	59
Nominal gear unit power PN1	[kW]	70
Nominal gear unit torque MN2	[Nm]	10900
Service factor FS		2.4
Mounting position		M1
Mounting surface		F1
Shaft position		123
Input shaft end	[mm]	38x80
LSS type		Solid shaft with key
Low speed shaft LSS [mm]	[mm]	100X210
Housing fixation		Foot mounting
Type of lubrication		Splash lubrication
Oil volume	[l]	22
Net weight	[kg]	340

Project

Project1

## User data

Type of driving machine		AC-motor
Operating hours/day [h]	[h]	>10
Operating cycle / hour ED [%]	[%]	100
Altitude [m above MSL]	[m]	0...< 1000
Installation site		Large rooms and halls
Ambient conditions		dry
Ambient temp. (min/max) [°C]	[°C]	-25/30

## Operating data

Motor power, nominal PM [kW]	[kW]	29.8
Input speed [r/min]	[1/min]	1200
Operating power PK1 [kW]	[kW]	29.8
Output power PK2	[kW]	29
Input torque MK1	[Nm]	235
Output torque MK2	[Nm]	4630
Start mode		Direct
Number of peak loads		1 - 5
Max. peak load torque MK2 max	[Nm]	0
Reversing operation		No

## Gear unit data

Catalog designation		X3FS120 /HU /B
Housing machining		Universal
Input speed [r/min]	[1/min]	1200
Ratio		20.26
Output speed n2	[1/min]	59
Nominal gear unit power PN1	[kW]	70
Nominal gear unit torque MN2	[Nm]	10900
Service factor FS		2.4
Mounting position		M1
Mounting surface		F1
Shaft position		123
Input shaft end	[mm]	38x80
LSS type		Solid shaft with key
Low speed shaft LSS [mm]	[mm]	100X210
Housing fixation		Foot mounting
Type of lubrication		Splash lubrication
Oil volume	[l]	22
Net weight	[kg]	340

# Options and accessories

Shaft type	Solid shaft
Shaft-hub type	Key
Rotation direction output	Both
Housing fixation	Foot mounting
Type of lubrication	Splash lubrication
Oil level check	Oil dipstick
Oil drain	Oil drain valve
Housing machining	Universal
Sealing system HSS	Dust-protected
HSS seal regreasing	
Sealing system LSS	Dust-protected
LSS seal regreasing	
LSS bearing variant	Standard
Oil cooling/oil heater	Yes
Fan	
Fan variant	Standard
Number of fans	1
Fan position	Fan on shaft end 1
Oil heater	Yes
Motor connection	Yes
Motor connection	Motor adapter
Adpater type	NEMA
Adapter	364/365
Motor flange diameter	13.0 " / (330 mm)
Through-going HSS	

**PARKS CANADA  
MACHINE GUARDING INSTALLATION AND  
MECHANICAL & ELECTRICAL COMPONENTS REPLACEMENT  
AT THE CARILLON NAVIGATION LOCK**

**ANNEX E**

**ANNEX E – BID FORM**

## ANNEXE E / ANNEX E

**TABLEAU DES PRIX FORFAITAIRES/LUMP SUM PRICE TABLE**

Article	Catégorie de main-d'œuvre, outillage ou matériaux/ Manwork, tools or materials category	Unité/ Unit	Qté/ Qty	Prix/Price
1	Gestion de l'entrepreneur / Contractor management	Lot	1	\$
2	Installation temporaire au chantier / temporary site installation	Lot	1	\$
3	Vanne secteur de la rive gauche / Sector Gate (left)	Lot	1	\$
3.1	Civil & structure	Lot	1	\$
3.2	Mécanique / Mechanical	Lot	1	\$
3.2.1	Protection-machine / Machine Guarding	Lot	1	\$
3.2.2	Système de graissage / Lubrication System	Lot	1	\$
3.3	Électrique / Electrical	Lot	1	\$
4	Vanne secteur de la rive droite / Sector Gate – Right	Lot	1	\$
4.1	Civil & structure	Lot	1	\$
4.2	Mécanique / Mechanical	Lot	1	\$
4.2.1	Protection-machine / Machine Guarding	Lot	1	\$
4.2.2	Système de graissage / Lubrication System	Lot	1	\$
4.3	Électrique / Electrical	Lot	1	\$
5	Valve d'admission Inlet Valve	Lot	1	\$
5.1	Civil & structure	Lot	1	\$
5.2	Mécanique / Mechanical	Lot	1	\$
5.2.1	Protection-machine / Machine Guarding	Lot	1	\$
5.2.2	Système de graissage / Lubrication System	Lot	1	\$
5.3	Électrique / Electrical	Lot	1	\$



Article	Catégorie de main-d'œuvre, outillage ou matériaux / Manwork, tools or materials category	Unité/ Unit	Qté/ Qty	Prix/Price
<b>6</b>	<b>Vanne d'évacuation / Outlet Valve</b>	<b>Lot</b>	<b>1</b>	<b>\$</b>
6.1	Civil & structure	Lot	1	\$
6.2	Mécanique / Mechanical	Lot	1	\$
6.2.1	Protection-machine / Machine Guarding	Lot	1	\$
6.2.2	Système de graissage / Lubrication System	Lot	1	\$
6.3	Électrique / Electrical	Lot	1	\$
<b>7</b>	<b>Porte verticale / Vertical Door</b>	<b>Lot</b>	<b>1</b>	<b>\$</b>
7.1	Civil & structure	Lot	1	\$
7.2	Mécanique / Mechanical	Lot	1	\$
7.2.1	Remplacement composantes mécaniques / Mechanical components replacement	Lot	1	\$
7.2.2	Réducteur / Gear Box	Ch.	1	\$
7.2.3	Frein ventilateur / Fan Brake	Ch.	1	\$
7.2.4	Protection-machine / Machine Guarding	Lot	1	\$
7.2.5	Système de graissage / Lubrication System	Lot	1	\$
7.3	Électrique / Electrical	Lot	1	\$
<b>8</b>	<b>Pompe électrique pour remplissage de graisse / Eletrical Pump for lubricant supply</b>	<b>Ch.</b>	<b>1</b>	<b>\$</b>
<b>9</b>	<b>Raccordement réseau salle électrique système de graissage / Connection network Electrical room lubrication system</b>	<b>Lot</b>	<b>1</b>	<b>\$</b>
<b>10</b>	<b>Installation permanent pour raccordement génératrice / Permanent installation for generator connection</b>	<b>Lot</b>	<b>1</b>	<b>\$</b>
10.1	Nouveau panneau CDP / New CPD pannel	Ch.	1	\$
	<b>TOTAL</b> (sans les taxes applicables / Excluding applicable tax(es):			