



Public Works and
Government Services
Canada

Travaux publics et
Services gouvernementaux
Canada

Canada



Serving
GOVERNMENT,
Serving
CANADIANS.

GOVERNMENT
OF CANADA

workplace 2.0

FIT-UP STANDARDS



APRIL 2012

Message from the Assistant Deputy Minister



Workplace renewal is a priority for the government. In the *Eighteenth Annual Report to the Prime Minister on the Public Service of Canada*, the Clerk of the Privy Council stressed this by stating that:

"A modern, healthy workplace supports greater productivity, a more engaged workforce and better results for Canadians. Deputies and managers have a responsibility to create workplaces that support the well-being, wellness and productivity of our employees."

Driven by this challenge for workplace renewal, we in Public Works and Government Services Canada have taken the lead in facilitating change across government, through the development and implementation of the government-wide Workplace 2.0 initiative.

Workplace 2.0 will create a modern workplace that will attract, retain and enable public servants to work smarter, greener and healthier to better serve Canadians. As a common service provider to the government, we are the ideal department to lead this initiative.

Innovation is the basis for Workplace 2.0's three pillars of renewal: the Workplace, the Back Office and the Way We Work. Together, these three integrated pillars provide for a renewed approach to the workplace, responding to a host of demographic, economic, environmental and technological factors. You can find more information on our website at <http://www.tpsgc-pwgsc.gc.ca/mt-wp/index-eng.html>.

Most recently updated in 2009, the *Fit-up Standards: Technical Reference Manual* introduced an innovative way to fit up space using "Integrated Workplace Solutions" or IWS. Since then, we have piloted the concept with comparative success. Workplace 2.0 builds on IWS concepts and as a result, the renamed and updated *Government of Canada Workplace 2.0 Fit-up Standards* incorporates Workplace 2.0 principles and continues to ensure a high quality of office accommodation across all federal departments and agencies, in all regions of the country.

In the *Government of Canada Workplace 2.0 Fit-up Standards*, the workplace is characterized by open, flexible and dynamic workspaces, which allows for innovative designs and better use of space. This approach is based on extensive research on how other public and private sector organizations are modernizing their workspaces. The standards continue to provide effective and productive work environments for employees, accommodating individual work styles, alternative work strategies and sustainable design principles, while also reducing the amount of space allocated for offices by 2 metres squared per person (from 16 m² to 14 m²).

Over the past seven years, our client departments have worked with us to rigorously apply the standards and we have appreciated the support and feedback. The *Government of Canada Workplace 2.0 Fit-up Standards* will continue to provide Public Works and Government Services employees, client departments and the private sector with direction and guidance on the fit-up of federal accommodations. Clearly Workplace 2.0 needs to be our de facto approach for office space now and for the future. I encourage you to enthusiastically apply the concepts and standards with our clients immediately. The results are amazing!

I am very energized by Workplace 2.0 and the benefits it has to offer and I look forward to working with you as we make Workplace 2.0 a reality across government. We encourage you to review the revised manual and to communicate with us at Amenagement.FITUP@tpsgc-pwgsc.gc.ca if you have any comments or questions.

Best regards,

John McBain, Assistant Deputy Minister
Public Works and Government Services Canada

Table of Contents



Section A: General-purpose Office Space

- A1. Introduction
 - A1.1 *Background/Context*
 - A1.2 *Application*
- A2. Approvals and Governance
 - A2.1 *Compliance with the Workplace 2.0 Fit-up Standards*
 - A2.2 *Compliance Monitoring*
 - A2.3 *Process for Approval of Non-compliance*
 - A2.4 *Submission Requirements*
 - A2.5 *Criteria for Evaluating Requests for Non-compliance*
 - A2.6 *Non-compliance Trends and Reporting*
- A3. Standards
 - A3.1 *Overview*
 - A3.2 *Funding Accountabilities of PWGSC and Client Departments*
 - A3.3 *Fit-up Components and Funding Accountabilities*
 - A3.4 *Office and Support Space Allocations*
 - A3.5 *Standards for Furniture Panels/Screens*
- A4. Special Technical Standards
 - A4.1 *Telecommunications Infrastructure*
 - A4.2 *Special Fire Protection Standards for Client-funded Requirements/SPS*
- A5. Planning
 - A5.1 *Planning and Workplace 2.0 Design Principles*
 - A5.2 *Sample Plans*
- A6. Sample Detail Drawings
 - A6.1 *Workstations, Collaborative and Enclosed Spaces*
 - A6.2 *Support Spaces*
 - A6.3 *Doors and Glazing*

- A7. Finishes
 - A7.1 *Finishes*
- A8. Costing
 - A8.1 *Workplace 2.0 Fit-up Rates*
 - A8.2 *Source of Funds for Non-compliant Workplace 2.0 Fit-up Components*
 - A8.3 *Cost Estimates*
 - A8.4 *Additional Direct and Indirect Costs*
 - A8.5 *Project Delivery Cost Controls*
- A9. Forms and Templates
 - A9.1 *Workplace 2.0 Fit-up Cost Estimate Template*
 - A9.2 *Workplace 2.0 Fit-up Compliance Monitoring Form*
 - A9.3 *Business Case Template*
 - A9.4 *Workplace 2.0 Worker Profile Identifier*
 - A9.5 *Workplace 2.0 Space Allocation Standards Calculator*



Section B: Guidelines for Ministerial and Deputy Head Accommodation

- B1. Introduction
 - B1.1 *General Information*
- B2. Guidelines
 - B2.1 *Fit-up Components and Funding Accountabilities*
 - B2.2 *Office and Support Space Allocations*
- B3. Planning
 - B3.1 *Planning and Design*
- B4. Sample Detail Drawings
 - B4.1 *Offices*
 - B4.2 *Support Spaces*
- B5. Costing
 - B5.1 *Cost Estimates*



Section C: Quasi-judicial Office Space

- C1. Introduction
 - C1.1 General Information*
 - C1.2 Application*
- C2. Standards
 - C2.1 Fit-up Components and Funding Accountabilities*
 - C2.2 Office and Support Space Allocations*
- C3. Planning
 - C3.1 Planning and Design*
 - C3.2 Sample Plans*
- C4. Sample Detail Drawings
 - C4.1 Support Space*
- C5. Costing
 - C5.1 Cost Estimates*



Section D: Call/Contact Centres

- D1. Introduction
 - D1.1 General Information*
 - D1.2 Application*
- D2. Standards
 - D2.1 Fit-up Components and Funding Accountabilities*
 - D2.2 Office and Support Space Allocations*
 - D2.3 Standards for Furniture Panels/Screens*
- D3. Planning
 - D3.1 Planning and Design*
 - D3.2 Sample Plan*
- D4. Sample Detail Drawings
 - D4.1 Typical Workstation Configurations*
 - D4.2 Support Space*

D5. Costing

D5.1 Cost Estimates



Resources

R1. Glossary

R2. Closed Office Assignments



Section A:

General-purpose Office Space



A1. Introduction

Changes Since the Last Update

A1.1 Background/Context

- Description of the Workplace 2.0 concept and the evolution of the *Workplace 2.0 Fit-up Standards*
- Reduction of the national average office accommodation allocation by 2 m²/FTE and the provision of a revised *Office Accommodation Space Allocation Standards*
- Addition of the new Call/Contact Centre Standards in Section D

A1.1 Background/Context

Workplace 2.0

The way we work has changed. Demographics, technology, mobility and sustainability have all had an impact on how and where we work. The current industry trend in office accommodation is towards smaller workstations that integrate new technologies, reflect worker profiles and time spent in the office; and government workplaces must keep up with these changes. In support of the eighteenth Annual Report to the Prime Minister, wherein the Clerk of the Privy Council pledged his commitment to workplace renewal, Public Works and Government Services Canada has taken the lead in facilitating this change through the implementation of Workplace 2.0, a government-wide strategy to create a modern workplace that will attract, retain and enable public servants to work smarter and greener to serve Canadians better.

Workplace 2.0 is based on three integrated pillars of change: the Workplace; the Back Office; and the Way We Work. The pillars embody modernizing the physical aspects of the workspace, updating policies, processes and systems that support public servants in their work, and providing the latest technologies that allow us to connect, collaborate and communicate across government and with Canadians. Workplace 2.0 optimizes office accommodation and applies a model that is consistent with private sector organizations and which other governments have adopted. It also respects policy and legislative requirements pertaining to the provision of federal workspace, including those of the Treasury Board Secretariat.

The 2009 *Fit-up Standards: Technical Reference Manual* was an integral part in the development of the first pillar of Workplace 2.0 (the Workplace), and introduced the initial concepts of space based on the functional requirements of workers and the amount of time spent in the workplace. In line with current Workplace 2.0 principles, and after a comprehensive review, the Standards have been revised to reflect the addition of Workplace 2.0. Renamed the *Government of Canada Workplace 2.0 Fit-up Standards*, they remain mandatory and will provide employees with a modern and efficient workplace, resulting in savings and ensuring best value for Canadians. The *Government*

of Canada Workplace 2.0 Fit-up Standards is a living document that will continue to be updated regularly to reflect recommended improvements identified through on-going feedback and research.

One of the main differences between the new *Government of Canada Workplace 2.0 Fit-up Standards* and past versions is that the new standards are fully based on the amount of time workers spend in the office, assigning smaller individual spaces and more group areas. Four types of worker profiles have been developed for workspaces as well as collaborative areas such as meeting rooms, teaming areas and quiet rooms. These areas are designed with the goal of providing spaces based on the way we work now, whether in teams, from alternate locations or in privacy. As well, in order to use our space more efficiently and better align our standards with what other governments and organizations are doing, the new *Workplace 2.0 Fit-up Standards* utilize reduced space allocation standards as outlined below.

Office Accommodation Framework

PWGSC's approach to fit-up is guided by PWGSC's *Framework for Office Accommodation and Accommodation Services*. Introduced in 1996, the Framework includes an accommodation policy and generic fit-up standards among other key elements. The primary messages of the Framework are that client departments and agencies share responsibility with PWGSC for applying standards for the quantity and quality of office accommodation, and that PWGSC is funded to provide office accommodation to client departments only to the level of the standards. The Framework states that the allocated space should be the minimum necessary to support the functional requirements of the occupant.

Annex A of the Framework originally provided the formulas to be used in establishing the maximum amount of usable space to be allocated nationally for standard office accommodation. For general administrative office space, the national average utilization rate was 16 m² per FTE (based on a sliding scale i.e. the higher the population, the lower the allocation per FTE).

The current trend in office accommodation is towards efficiency in space utilization, more collaboration and smaller individual workstations that integrate new technologies and reflect the amount of time spent in the office. In order to respond to new ways of working and align with other governments and organizations in the efficient use of space, a revised Annex A, now entitled *Space Allocation Standards*, was developed in 2012, reducing the national average allocation of office accommodation from 16 m² to 14 m² per FTE.

Principles

PWGSC's Real Property Branch continues to be mandated to provide affordable and sustainable office accommodation and related services for federal government departments and agencies. These services include the fit-up of office space to meet client department program requirements within the limits of the *Workplace 2.0 Fit-up Standards*.

Fit-up, which represents a significant portion of PWGSC Real Property business, includes the preparation of accommodation for initial federal occupancy, and the alteration of existing space for reuse by a different client department or agency.

The *Workplace 2.0 Fit-up Standards* specify a midrange quality for construction components and finishes considered to be part of a typical fit-up for general-purpose office space. This is often referred to as the standard “bundle of goods” delivered by PWGSC on all fit-up projects regardless of location or client.

The standard is quality, not cost based. In other words, the same “bundle of goods” is delivered on fit-up projects across the country, regardless of any regional cost variances. The fit-up components and finishes incorporate the fundamental aspects of a modern, flexible, environmentally sustainable and supportive work environment.

Introduced in 2005, controls continue to be incorporated into the process for delivering fit-up projects to help constrain costs and avoid delays to the project schedule. This includes the “two revision rule” limiting the number of revisions a client can request per design stage. (For more information on project controls, refer to A8.5.)

Standardization of fit-up projects and components is intended to:

- achieve cost-effective and timely delivery of accommodation and accommodation services;
- clearly define accountabilities;
- improve understanding of PWGSC’s real property program;
- ensure equity and consistency in federal accommodation thereby facilitating relocations;
- incorporate the fundamental aspects of environmental sustainability and supportive work environments; and
- demonstrate value to Canadian citizens through improved management of federal accommodation.

What’s New in 2012

Although the Fit-up Standards have always been reviewed and updated to ensure they respond to the needs of the modern office environment and respect government policy and priorities, in 2012 a major revision was undertaken to fully align the Fit-up Standards with Workplace 2.0 principles. The General-purpose Office Space Standards have been updated to incorporate these changes. Clarifications to the text have been made throughout the document, however, the most notable changes and additions are as follows:

A1.1 Background/Context

- ◆ Description of the Workplace 2.0 concept and the evolution of the *Workplace 2.0 Fit-up Standards*.

- ◆ Reduction of the national average office accommodation allocation by 2 m²/FTE and the provision of revised *Office Accommodation Space Allocation Standards*.
- ◆ Addition of the new Call/Contact Centre Standards in Section D.

A2.4 Submission Requirements

- ◆ Clarification on the requirement for a third party Threat and Risk Assessment for business case justifications based on security.

A3.1 Overview

- ◆ Description of the benefits of Workplace 2.0 spaces.

A3.2 Funding Accountabilities of PWGSC and Client Departments

- ◆ Introduction of new tables for PWGSC and client department funding accountabilities and mechanisms for obtaining funding.

A3.3 Fit-up Components and Funding Accountabilities

- ◆ Change to the size and composition of large meeting rooms i.e. large meeting rooms to be divided by a retractable or folding partition wall to increase flexibility (PWGSC cost).
- ◆ Clarification to the use of carpet inserts for way finding and durability in major circulation paths.
- ◆ Clarification that raised floor systems and ramps etc. (client cost) are not subject to the non-compliance approval process.
- ◆ Clarification that base building and core area plumbing services do not include hard plumbed water coolers.
- ◆ Clarification to the funding of sound masking systems.
- ◆ Additional information on the definition of exterior window coverings.
- ◆ Removal of overhead shelving systems and addition of storage towers as part of integrated and mobile furnishings.
- ◆ Change to the funding of plants, planters and related ongoing maintenance.

A3.4 Office and Support Space Allocations

- ◆ Definitions and workstation/office sizes provided for worker profile types (leadership, fixed, flex and free).
- ◆ Workstation sizes changed to a maximum 4.5 m².
- ◆ Enclosed office space allowances for senior managers changed to a maximum of 18.5 m² and a revised allocation chart provided.
- ◆ Clarification on the use of the undesignated support space allocation for Law (LA) and Informal Conflict Management System (ICMS) employees.
- ◆ Revision to meeting room allowances.

- ◆ Clarification to large meeting room definition and size (as per A3.4).
- ◆ Revision to undesignated support space size, allowance and usage.
- ◆ Description of collaborative spaces and the planning ratio to be used.
- ◆ Revision to the planning ratio for printer stations.

A3.5 Standards for Furniture Panels/Screens

- ◆ Revision to the maximum height for panels/screens and modification to panel/screen finishes.
- ◆ Revision to the use of glass panels on screens.

A5.1 Planning and Workplace 2.0 Design Principles

- ◆ Additional information on the overall Workplace 2.0 concept and general physical workplace planning principles.
- ◆ Division of "Design Principles" section into subheadings with additional planning details in each section.

A5.2 Deletion of "Integrated Workplace Solutions" section

A5.2 Sample Plans

- ◆ New PL1 and PL 2 floor plans, planning notes and legends applying Workplace 2.0 standards with a planning ratio of 60% fixed, 30% flex and 10% free workers.
- ◆ New PL3 and PL 4 floor plans, planning notes and legends applying Workplace 2.0 standards with a planning ratio of 75% fixed, 20% flex and 5% free workers.

A6.1 Workstations, Collaborative and Enclosed Spaces

- ◆ Modification to examples of workstation and enclosed office layouts.
- ◆ Clarification and description of collaborative spaces and new examples of collaborative space layouts.

A6.2 Support Spaces

- ◆ Additional data/electrical outlets in medium and large meeting rooms, mandatory retractable wall in large meeting room and revision to examples of meeting room layouts.
- ◆ Addition of barrier free wording for quiet rooms and optional layout examples provided.
- ◆ Optional freestanding manufactured solution for upper and lower cabinets in kitchenettes and shared equipment areas.
- ◆ Addition of ceramic tile backsplash in kitchenettes and update to drawings.

A6.3 Doors and Glazing

- ◆ Addition of glazed doors (with frames) as part of a demountable/moveable wall system.

A7.1 Finishes

- ◆ Clarification that carpet tiles, rather than rolled goods are recommended.

A8.1 Workplace 2.0 Fit-up Rates

- ◆ New rates for 2012-2013.

A8.3 Cost Estimates

- ◆ New cost estimate sample for fit-up projects.

A9.4 Workplace 2.0 Worker Profile Identifier

A9.5 Workplace 2.0 Space Allocation Standards Calculator

How to Use this Manual

The *Workplace 2.0 Fit-up Standards* is organized in sections according to the various types of office space provided by PWGSC to departments and agencies, and includes additional resources at the end:

- Section A: General-purpose Office Space Standards – provides the baseline standards for fit-up of all Government of Canada office accommodation.
- Section B: Guidelines for Ministerial and Deputy Head Office Accommodation – identifies additional allowances for fit-up of office accommodation for ministers, deputy heads and associate deputy ministers.
- Section C: Quasi-judicial Office Space Standards – identifies additional allowances for fit-up of quasi-judicial office space.
- Section D: Call/Contact Centre Standards – identifies additional allowances for fit-up of call/contact centre space.
- Section R: Resources – defines the key terms and provides references.

Unless otherwise specified, all figures are in **usable** metres squared.

Note: We support 'green practices' and are attempting to keep the paper copies of this manual to a minimum. We, therefore, encourage you to refer to the standards on the PWGSC Internet site. Government of Canada employees can also access the manual at <http://publiservice.tpsgc-pwgsc.gc.ca/amenagement/text/new-e.html>. Updates to the standards and information on precedent-setting approvals are posted on the PWGSC Internet site as well as the Publiservice site. We invite you to visit the sites regularly.

A1.2 Application

It is important to remember that the implementation of Workplace 2.0, as well as the standardization of fit-up projects, will continue to contribute to cost savings for other Government of Canada priorities and, as such, is supported at the highest levels within government. Among the significant benefits for all stakeholders, applying the standards will result in an affordable, modern, flexible and supportive work environment for federal accommodations and a consistent quality of work environment for federal employees.

The *Workplace 2.0 Fit-up Standards* apply to:

- All office accommodation under the administration of PWGSC as provided to federal departments and agencies, whether reimbursing or non-reimbursing. This includes the generic office space categories (general administrative, secure administrative, and quasi-judicial office space) and call/contact centre standards as well as guidelines for ministerial and deputy head office accommodation. The additional security requirements of secure administrative office space are addressed in A3.3, therefore, separate standards are not provided. Allowances for minister and deputy head office accommodation, quasi-judicial office space as well as call/contact centre standards are provided in Sections B, C and D, respectively, of this manual. **Note:** The *Workplace 2.0 Fit-up Standards* also apply, in spirit and intent, to standard fit-up components provided in special purpose space (SPS), although it is recognized that this space type will have special technical and fit-up requirements.
- Alterations and/or improvements to the above-noted accommodation including:
 - Fit-up for initial occupancy;
 - Tenant service work requested and funded by the client. Tenant service work shall NOT result in a quality of office accommodation higher than that permitted by the *Workplace 2.0 Fit-up Standards*; and
 - Fit-up of existing space for reuse by a different PWGSC client. The scope of this fit-up shall take into account the functional requirements of the client, existing conditions of the previously occupied space, and the duration of the occupancy.

The *Workplace 2.0 Fit-up Standards* do not apply to:

- Real property under the administration of Crown Corporations and other custodial departments. However, where PWGSC provides optional services to departments and agencies, the department shall promote and recommend the application of the standards; and
- Office accommodation provided for House of Commons, Senate and Library of Parliament.

All custodial departments are encouraged to adopt and apply the *Government of Canada Workplace 2.0 Fit-up Standards* to support a government-wide approach.

A2. Approvals and Governance

Changes Since the Last Update

A2.4 Submission Requirements

- Clarification on the requirement for a third party Threat and Risk Assessment for business case justifications based on security.

A2.1 Compliance with the Workplace 2.0 Fit-up Standards

The *Workplace 2.0 Fit-up Standards* are supported by Treasury Board Secretariat and PWGSC at all management levels with the application and enforcement of a rigorous system of implementation. It is the responsibility of both PWGSC and client departments to work within the Standards.

Non-compliance

Client requests that would result in a fit-up of either higher or lower quality or that otherwise would create non-standard office accommodation will be considered non-compliant. All non-compliance is subject to the approval process.

Common Sense and Best Value for Canadians

The *Workplace 2.0 Fit-up Standards* are the baseline for the identification of non-compliance; however, there can never be a substitute for sound judgment and common sense. The project team must use the Standards wisely and question the validity of each of its components against the problem at hand.

An overall advantage to the taxpayer and the Crown takes precedence over benefits to a particular client and these Standards. However, minor adjustments to the approach or to the typical provisions included in the *Workplace 2.0 Fit-up Standards* that can benefit the client without having adverse impact on the planning principles, project quality or cost, may be considered.

For example, in certain situations, coat storage may be more appropriate and useful to the client than cabinet storage in a shared equipment area, and an exchange of these fit-up components is deemed acceptable.

Also, if a space is leased “as is”, but the hard walled spaces are not sized according to the Standard (larger or smaller) or the number exceeds the allocation, it may **not** demonstrate sound judgment or sustainability (economic or environmental) to “right size” or demolish the spaces. In such cases, hard walled office spaces in excess of the standard allocations could be used to accommodate two or more workstations.

Similarly, modifications to the Standard may have to be considered to allow for specific requirements of heritage buildings.

Note: The project team must document any decisions made (including justification for audit purposes) before proceeding with implementation. (Refer to A2.2 for further information on compliance monitoring.)

Approval Authorities for Non-compliance with the *Workplace 2.0 Fit-up Standards*

The Accommodation Standards Committee (ASC) has been established in PWGSC to help ensure a disciplined, objective, and consistent approach to decision-making, monitoring and reporting on the implementation of the *Workplace 2.0 Fit-up Standards*. The ASC evaluates all requests from departments and agencies for exemptions from the *Space Allocation Standards* and the *Workplace 2.0 Fit-up Standards*, and prepares a recommendation to the ADM, Real Property Branch (RPB). The ADM, RPB, has the authority for approval of requests for non-compliance with the *Workplace 2.0 Fit-up Standards*.

In client departments and agencies, it is recommended that a comparable level of authority be identified to approve the department’s or agency’s justified requests for non-compliance, to approve the funding, and to accept accountability for the decisions and any project delays, if applicable.

A2.2 Compliance Monitoring

It is critical that both the client department and PWGSC exercise due diligence in protecting the interests of the Crown and the taxpayer with regard to federal accommodation spending.

Fit-up Projects

The delivery of fit-up projects follows the PWGSC National Project Management System (NPMS). Each phase of the process and each deliverable represents an opportunity to validate compliance or non-compliance with the *Workplace 2.0 Fit-up Standards*.

The completion of the Client Requirements Checklist at the Project Identification Stage, and the subsequent development of the Functional Program, where required, and Investment Analysis Report (IAR) will put to the forefront any potential non-compliance with the Standards. Compliance continues to be monitored at each subsequent phase of the project. Where non-compliance occurs, the Workplace 2.0 Fit-up Compliance Monitoring Form is to be completed. The form serves to record the nature of the request, the costs, the recommendation of the project team, and the decision of the Assistant Deputy Minister, Real Property Branch (ADM, RPB), on approval. (Refer to A2.3 for the approval process and A9.2 for a copy of the Compliance Monitoring Form.)

The client department is responsible for submitting the justification or business case for each non-compliance request, providing the funding, and accepting accountability for any delays in the project incurred by the approval process. (Refer to A2.4 for details on the submission requirements for requests for non-compliance approval.)

As described in A2.1 Compliance with the *Workplace 2.0 Fit-up Standards*, in some cases the project team may determine that minor adjustments to the Standards provide the optimum solution, represent common sense and best value to the Crown, and would not require approval of the ADM, RPB. Such decisions and their justification must be documented on the Workplace 2.0 Fit-up Compliance Monitoring Form, and the form attached to the project file.

Tenant Service Projects

Tenant service projects must be similarly monitored for compliance with the *Workplace 2.0 Fit-up Standards*. Requests for non-compliant fit-up elements are to be recorded on the Workplace 2.0 Fit-up Compliance Monitoring Form, and approved in accordance with the approval process outlined in A2.3.

Note: Reimbursing departments are subject to the same compliance monitoring process as non-reimbursing departments. As well, contracted services are monitored through performance-based contracts and their work is subject to audit to assure compliance with the *Workplace 2.0 Fit-up Standards*.

A2.3 Process for Approval of Non-compliance

Project-specific Requests

The following flowchart and table describe the national process for managing requests for exemptions to the *Workplace 2.0 Fit-up Standards* and/or *Space Allocation Standards* related to fit-up or tenant service projects.

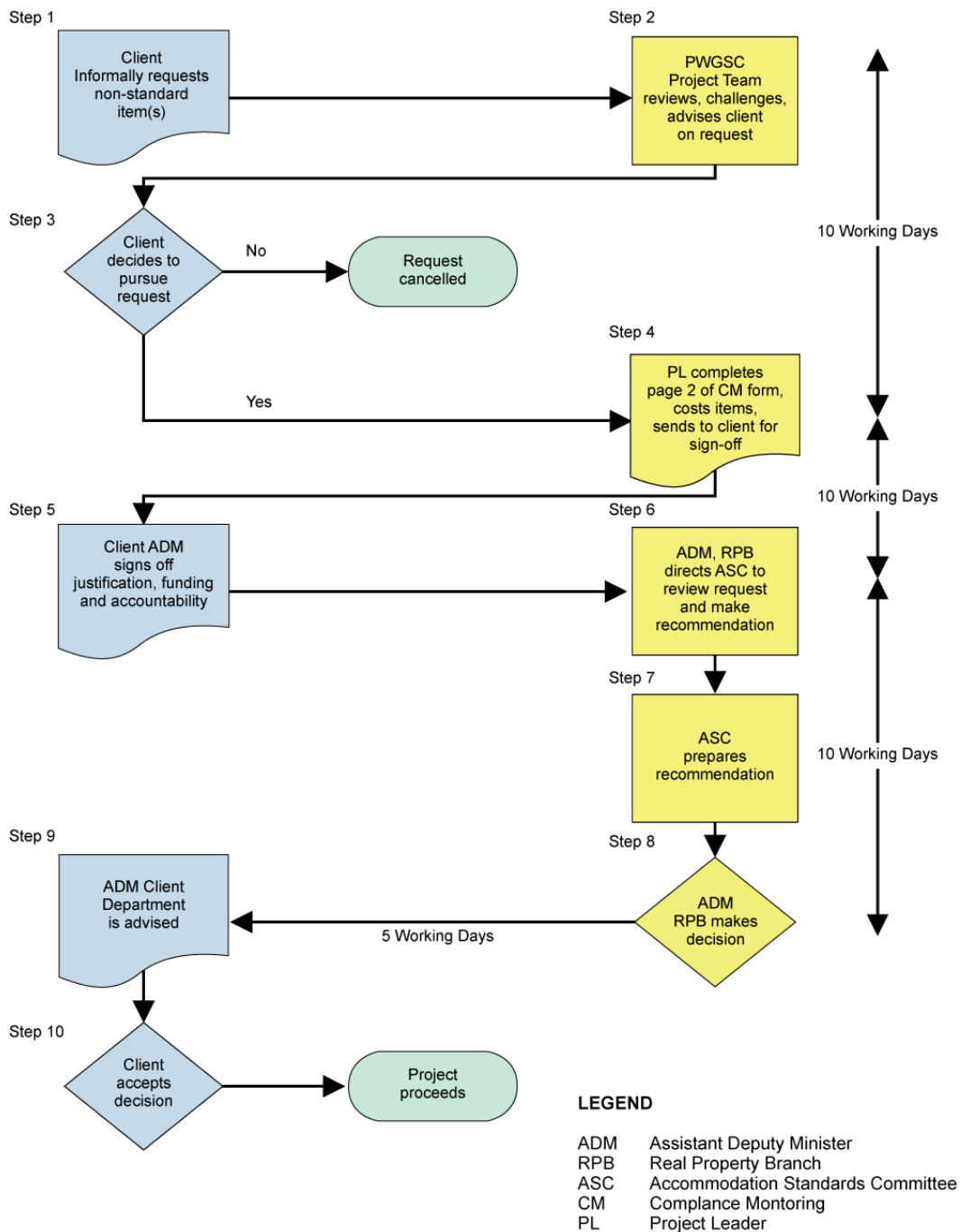

Step 1 Client	.1 Client makes informal request for non-compliant item(s) to PWGSC, Project Leader (PL): <ul style="list-style-type: none"> Accommodation Management, if a fit-up project; Asset and Facilities Management or AFD Service Provider, if tenant service work.
Step 2 PWGSC	.1 PL reviews the request in consultation with project team. .2 Project team confirms that request exceeds <i>Workplace 2.0 Fit-up Standards</i> and/or <i>Space Allocation Standards</i> and determines whether to support it based on the evaluation criteria in A2.5 .3 PL advises client on: <ul style="list-style-type: none"> whether or not the project team will support the request; and the impact on project delivery of implementing the non-compliance approval process.
Step 3 Client	.1 If client decides not to pursue request, process is terminated. .2 If client decides to pursue request, proceed to step 4.
Step 4 PWGSC	.1 PL fills out Compliance Monitoring Form, listing and costing each non-compliant item, and attaches to project file. .2 PL provides client with a copy of the form and requests that it be completed and submitted in a business case to request approval of the ADM, Real Property Branch (RPB), in accordance with this approval process in A2.3 and the submission requirements in A2.4.
Step 5 Client	.1 Client completes and signs the compliance monitoring form and prepares business case providing the justification for the request, and acknowledging accountability for funding of additional costs and for associated project delays. This is signed off at a level of authority comparable to an ADM, and sent to the ADM, RPB.
Steps 6 – 8 inclusive, to be completed within 10 working days	
Step 6 PWGSC	.1 ADM, RPB directs the Accommodation Standards Committee (ASC) to review the business case, and make a recommendation on approval.
Step 7 PWGSC	.1 ASC reviews request and makes recommendation on approval, prepares letter of response and forwards to ADM, RPB, through the Director General, Accommodation Portfolio Management and Real Estate Services.
Step 8 PWGSC	.1 ADM, RPB reviews recommendation and makes decision. .2 ADM, RPB signs letter of response to client department, advising of decision and the rationale on which it is based.
Step 9, to be completed within 5 working days	
Step 9 PWGSC	.1 Client department ADM is advised of decision through letter from ADM, RPB.
Step 10	.1 Client department accepts decision, and project proceeds.

Note: Timelines for preparation and submission of the non-compliance request will vary depending on the complexity of the request and project requirements. The department or agency is the lead in preparing and submitting documentation and accepts accountabilities for project delays.

Program-specific Requests

The following flowchart and table describe the national process for managing requests for exemptions to the *Workplace 2.0 Fit-up Standards* and/or *Space Allocation Standards* and for approval of special purpose space that is intended for application on a department-wide or program-specific basis.

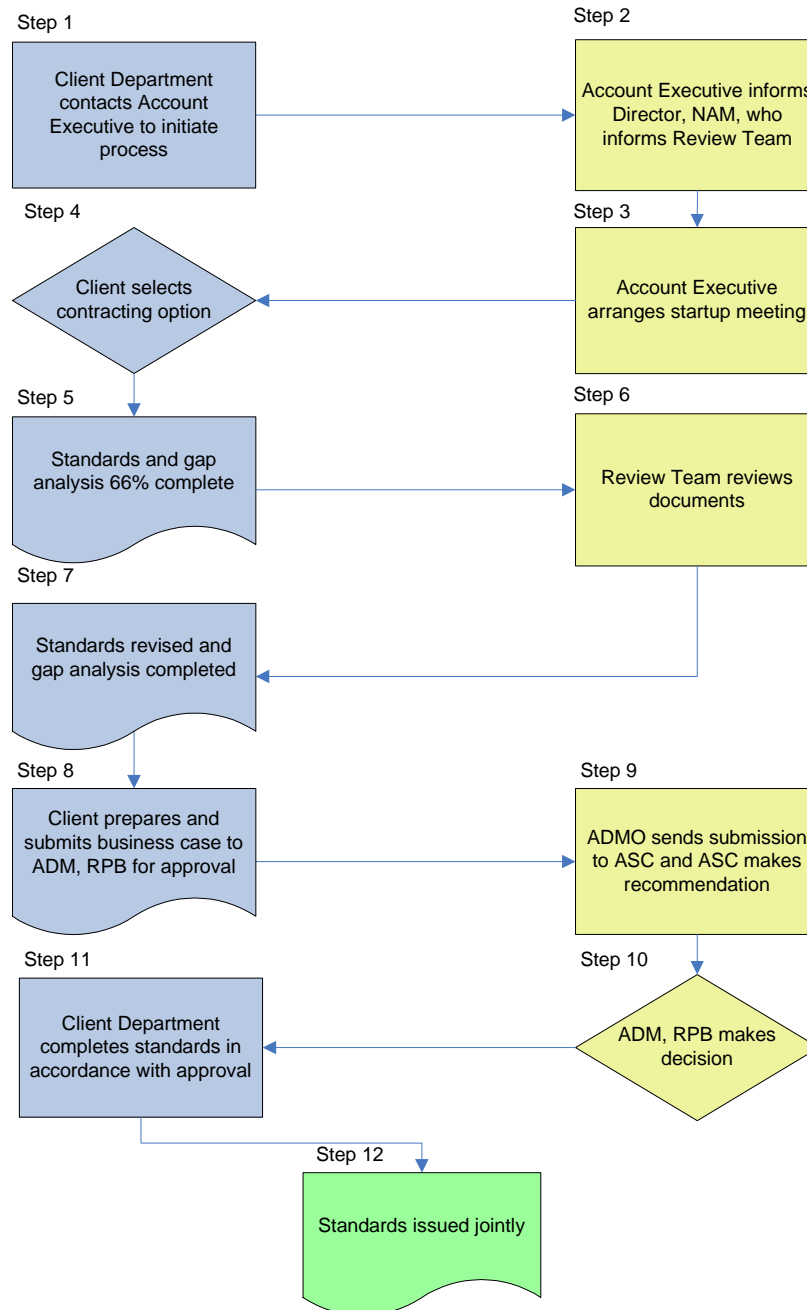

Step 1 Client	.1 Client Department informs Account Executive in writing of intent to develop accommodation standards for program-specific requirements.
Step 2 PWGSC	.1 Account Executive informs Director, National Accommodation Management (NAM). .2 Director, NAM, informs the Review Team which includes: <ul style="list-style-type: none"> - Account Executive - Analyst, SAAG, NAM - Director, NAM - Manager, Architecture and Interior Design (A&ID), National Capital Area (NCA), and Designer - Manager, Workplace Strategies and Standards, NAM - Regional Managers, Accommodation Management - Manager, Strategic Accommodation Advisory Group (SAAG), NAM
Step 3 PWGSC	.1 Account Executive arranges startup meeting with Client Department and members of review team (A&ID; Manager, SAAG; Manager, Workplace Strategies and Standards; Analyst, SAAG) to discuss process, contracting options for consultant services and impacts on funding.
Step 4 Client <u>Option 1</u>	Consultant hired through A&ID (Option 1) .1 Client Department obtains consultant services through A&ID. .2 A&ID prepares scope of work and specific service agreement (SSA) and obtains markup factor from Account Executive and enters project in SIGMA. Note: This is the recommended option as it ensures A&ID and the Analyst, SAAG, are involved in the review of all deliverables and that the process is followed.
Step 4 Client <u>Option 2</u>	Consultant hired by Client Department (Option 2) .1 Client Department contracts for services. Note: With this option, Client Department must keep the Analyst, SAAG, informed, and will be responsible for funding A&ID costs where their services are required for a quality assurance (QA) review.
Step 5 Client <u>Option 1</u>	Consultant hired through A&ID (Option 1) .1 A&ID and Consultant work with Client Department to develop standards and gap analysis. .2 A&ID manages contract and monitors deliverables. .3 A&ID and Client Department review deliverables. .4 A&ID consults with Analyst, SAAG, and provides updates. .5 Client Department forwards standards (66% complete) and gap analysis to Account Executive.
Step 5 Client <u>Option 2</u>	Consultant hired by Client Department (Option 2) .1 Consultant works with Client Department to develop standards and gap analysis. .2 Client Department monitors contract, reviews deliverables. .3 Client Department consults with Analyst, SAAG, and provides deliverables at 33% completion stage to ensure A&ID QA review and alignment with project objectives. .4 Client Department forwards standards (66% complete) and gap analysis to Account Executive.
Step 6 PWGSC	.1 Account Executive forwards submission to the Director, NAM. .2 Director, NAM, forwards it to the Review Team. .3 Review Team reviews documents, identifies issues, confirms special purpose space and non-compliant support space and provides comments to Manager, Workplace Strategies and Standards. .4 Manager, Workplace Strategies and Standards, compiles final comments and forwards to the Account Executive. .5 Account Executive forwards comments to Client Department.
Step 7 Client	.1 Consultant revises standards and completes gap analysis to reflect PWGSC comments. Note: Standards are not to be completed until the decision on approval of non-compliant fit-up and SPS has been received (Step 11).

Step 8 Client	<ul style="list-style-type: none"> .1 Client Department prepares business case to justify the request for approval of non-compliant fit-up and SPS, in consultation with the Analyst, SAAG (see A2.4 for submission requirement). .2 Client Department submits request for approval on non-compliant fit-up elements and SPS to the ADM, RPB. .3 ADM's office forwards request to the Director, NAM, as chair of the Accommodation Standards Committee (ASC), through the DG Accommodation Portfolio Management and Real Estate Services (APMRES).
Step 9 PWGSC	<ul style="list-style-type: none"> .1 Director, NAM, sends copy of submission to the ASC. .2 ASC reviews submission and makes final recommendation on approval. .3 ASC prepares letter of response with recommendation on approval, forwards to DG, APMRES, for transmittal to the ADM, RPB.
Step 10 PWGSC	<ul style="list-style-type: none"> .1 ADM, RPB, sends letter to inform the Client Department of decision on approval. Letter is copied to the Account Executive and Director, NAM. .2 Director, NAM, communicates decision to ASC and Review Team.
Step 11 Client	<ul style="list-style-type: none"> .1 Client Department finalizes standards based on approval and submits to Account Executive for PWGSC final review.
Step 12 Client and PWGSC	<ul style="list-style-type: none"> .1 Once the standards are finalized and agreed to by the Client Department and PWGSC, they are issued in a joint communiqué.

Note: Timelines for client departments to prepare and submit non-compliance requests for program-specific requirements, and for PWGSC to review, will vary depending on the scope and complexity of the request.

A2.4 Submission Requirements

PWGSC

Project-specific Requests

PWGSC Project Leaders are to send an e-mail to the chair of the ASC informing the committee of a department's or agency's decision to pursue a non-compliance request. E-mails are to include the following information:

1. Description of non-compliance request;
2. Summary of relevant facts and issues;
3. Impact of request on accommodation savings and space reduction targets;
4. Position of the project team; and
5. Copy of Workplace 2.0 Fit-up Compliance Monitoring Form.

Client Department or Agency

Project-specific and Program-specific Requests

Departments and agencies must submit their requests for exemptions from the *Workplace 2.0 Fit-up Standards* and for national special purpose space to the ADM, RPB, for approval.

Requests for non-compliance must be accompanied by a justification, client department senior management level approval, confirmation of funding, and acceptance of accountability for any project delays incurred in the approval process. The funding will cover all direct and indirect costs related to the implementation of the non-compliant item or service, including management and design services, project delays, and ongoing operational and maintenance costs.

Submissions are to be prepared in consultation with PWGSC, and must include the following information:

1. Cover letter to ADM, RPB, from the ADM of the client department or agency (or comparable authority), including:
 - official request for approval of non-compliant item(s) and/or national special purpose space;
 - commitment to fund all additional costs; and
 - acceptance of accountability for any related project delays.
2. Business case (2-3 pages per item requested) including:
 - (a) Purpose
 - (b) Background/Context
 - ◆ Mandate of the department/agency

- ◆ Strategic considerations
- ◆ Description and status of related project(s)
- ◆ Location (program-specific)

(c) Non-compliant Fit-up Request(s)

- ◆ Issue
- ◆ Options analysis
- ◆ Description
- ◆ Gap analysis (with *Workplace 2.0 Fit-up Standards* and *Space Allocations Standards*)
- ◆ Cost impact analysis
- ◆ Benefits and risks
- ◆ Recommendation and Justification
(**Note:** If the justification is based on security requirements, see Justification Based on Security Requirements, below.)

(d) National Special Purpose Space Requests (Program specific only)

- ◆ Issues
- ◆ Options analysis
- ◆ Description
- ◆ Recommendation and justification

(e) Funding Accountability

Appendices

- Workplace 2.0 Fit-up Standards Compliance Monitoring Form
- Other documents, as appropriate:
 - ◆ Detailed gap analysis
 - ◆ Legislation, TB policies, TB minutes, reports, studies
 - ◆ Floor plans
 - ◆ Threat and Risk Assessment, Security Design Brief, Security Site Brief or letter from the Departmental Security Officer
 - ◆ Organization charts
 - ◆ Functional Program
- Draft program-specific standards (for program-specific requests)

Note: A business case template is provided in A9.3.

Justification Based on Security

When the recommended option is based on security, the justification submitted by the client department or agency must include:

- Reference to text within a third party Threat and Risk Assessment, Security Design Brief or Security Site Brief that specifically supports the request. If these documents are not available, they must be developed before the business case is submitted;
- In the case of project-specific requests, if there is sufficient reason for not developing any of the above-noted documents, a letter from the Departmental Security Officer must be provided and include, where appropriate:
 - a statement of the security requirement necessitating the non-compliant fit-up;
 - an explanation as to why zoning is not an acceptable alternative;
 - the security classification of the information being handled i.e., Confidential, Secret, Top Secret, Protected A, B, or C; and
 - legal liabilities.

Information on Government of Canada security requirements including approaches to physical security and the selection and design of facilities can be found in the [Government Security Policy](#), and in the [Operational Security Standard on Physical Security](#).

A2.5 Criteria for Evaluating Requests for Non-compliance

The Accommodation Standards Committee uses the following criteria to evaluate requests for exemption to the *Workplace 2.0 Fit-up Standards*.

1. Is the request a program requirement?
2. Is the request due to a health and safety issue?
3. Have alternate solutions been appropriately considered?
4. Is the request in the best economic interest of the Crown and taxpayer?
5. Does the request demonstrate sound judgment and common sense?
6. Does the request have an impact on the achievement of accommodation savings?

A2.6 Non-compliance Trends and Reporting

The Accommodation Standards Committee monitors the requests received for non-compliance and regularly reports to senior management on progress towards the broad objectives of the *Workplace 2.0 Fit-up Standards*. Summary reports are submitted at the end of each month to the Assistant Deputy Minister and the Associate Assistant Deputy Minister, Real Property Branch.

A summary report is posted on the [Publiservice Workplace 2.0 Fit-up Standards Web site](#) at the end of each fiscal year.

Non-compliance requests are reviewed periodically, and evident trends are assessed when updating the *Workplace 2.0 Fit-up Standards*.

A3. Standards

Changes Since the Last Update

A3.1 Overview

- Description of the benefits of Workplace 2.0 spaces.

A3.2 Funding Accountabilities of PWGSC and Client Departments

- Introduction of new tables for PWGSC and client department funding accountabilities and mechanisms for obtaining funding.

A3.3 Fit-up Components and Funding Accountabilities

- Change to the size and composition of large meeting rooms i.e. large meeting rooms to be divided by a retractable or folding partition wall to increase flexibility (PWGSC cost).
- Clarification to the use of carpet inserts for way finding and durability in major circulation paths.
- Clarification that raised floor systems and ramps etc. (client cost) are not subject to the non-compliance approval process.
- Clarification that base building and core area plumbing services do not include hard plumbed water coolers.
- Clarification to the funding of sound masking systems.
- Additional information on the definition of exterior window coverings.
- Removal of overhead shelving systems and addition of storage towers as part of integrated and mobile furnishings.
- Change to the funding of plants, planters and related ongoing maintenance.

A3.4 Office and Support Space Allocations

- Definitions and workstation/office sizes provided for worker profile types (leadership, fixed, flex and free).
- Workstation sizes changed to maximum 4.5 m².
- Enclosed office space allowances for senior managers changed to a maximum of 18.5 m² and a revised allocation chart provided.
- Clarification on the use of the undesignated support space allocation for Law (LA) and Informal Conflict Management System (ICMS) employees.
- Revision to meeting room allowances.
- Clarification to large meeting room definition and size (as per A3.4).
- Revision to undesignated support space size, allowance and usage.
- Description of collaborative spaces and the planning ratio to be used.
- Revision to the planning ratio for printer stations.

A3.5 Standards for Furniture Panels/Screens

- Revision to the maximum height for panels/screens and modification to panel/screen finishes.
- Revision to the use of glass panels on screens.

A3.1 Overview

A3.2 to A3.5 describe in detail the standards for space allocation, construction components and finishes that form the basis of a fit-up project. More specifically:

- A3.2 provides the funding accountabilities of PWGSC and client departments in terms of mechanisms for obtaining funding;
- A3.3 identifies the funding accountabilities for each typical project component and underlines the importance of correctly identifying and recording project costs;
- A3.4 provides detailed information on office assignment criteria and support space and related millwork provisions for various population ranges;
- A3.5 identifies the attributes of workstation panels (screens) that are specific to the *Workplace 2.0 Fit-up Standards*.

The Standards respond to government programs and priorities, and are compliant with all relevant codes, life safety and accessibility standards.

By emphasizing a consistent and sustainable approach to construction and finishing, providing smaller individual workstations and more open collaborative areas, and by limiting the number of enclosed offices and support spaces, the Standards will help the government use space more efficiently. This approach will also facilitate relocations and the reuse of space by other departments/agencies, as well as provide innovative workplaces to meet the needs of a diverse workforce.

Base Building Standards

The starting point for any fit-up project is determined by the base building conditions. Whether the facility is Crown-owned or leased, base building conditions will always vary depending on the location, age, size, classification and other characteristics of the site. In leased space, the extent of the landlord's responsibility with respect to those conditions is as outlined in the PWGSC Generic Lease Documentation Package and finalized through lease negotiations. No modifications may be made to the base building components other than those itemized in the lease agreements or otherwise taken into account in making the original investment decision.

The base building standards, currently undergoing final approvals, will form the basis for facilities occupied by the federal government and will be the primary reference for all technical and life safety standards related to plumbing, HVAC, fire protection, electrical and telecommunication systems.

Note: All fit-up projects must be in accordance with the appropriate municipal and provincial codes and consideration must be given to the potential impact of densification on base building systems.

A3.2 Funding Accountabilities of PWGSC and Client Departments

Funding accountabilities for fit-up projects are shared between PWGSC and the client departments. The following tables describe PWGSC and client department funding accountabilities in terms of the nature of the occupancy instrument, whether for non-reimbursing, reimbursing or expansion space; as well as mechanisms for obtaining funding, and apply whether a project is implemented in a Crown-owned or leased facility.

Non-reimbursing Occupancy Instruments (OIs)						
Inventory Impact		Project Description	Fit-up Components (see Fit-up Standards A3.3)	Funding Department	Mechanism for Obtaining Funding*	
Existing OI	During Term of Occupancy	Tenant Services: Alterations to Existing Accommodation	Base Building	Client	SSA	
			Standard Fit-up			
			Other			
		Cyclical Maintenance: Repair or Replacement	Base Building	PWGSC	FAH (BMP/WPM) ^{1,2}	
			Standard Fit-up			
			Other	Client	SSA	
New OI	Same Location: OI Renewal or OI & Lease Renewal (with or without a space reduction)	Tenant Services: Alterations to Existing Accommodation	Base Building	Client	SSA	
			Standard Fit-up			
			Other			
		Cyclical Maintenance: Repair or Replacement	Base Building	PWGSC	FAH (BMP/WPM) ^{1,2}	
			Standard Fit-up			
			Other	Client	SSA	
	New Location: Expansion or Replacement	Fit-up for Initial Occupancy or Fit-up of Existing Space for Reuse	Base Building	PWGSC	FAH (BMP/WPM) ²	
			Standard Fit-up			
			Other	Client	SSA	
	Major Renovations by PWGSC	Fit-up of Swing Space for Initial Occupancy or for Reuse	Base Building	PWGSC	FAH (BMP/WPM) ²	
			Standard Fit-up			
			Other			
		Fit-up of Long Term Space for Reuse (i.e. move back to original location)	Base Building	PWGSC	FAH (BMP/WPM) ²	
			Standard Fit-up			
			Other	Client	SSA	
	Major Renovations by PWGSC & Client Department	Fit-up of Swing Space for Initial Occupancy or for Reuse	Base Building	PWGSC	FAH (BMP/WPM) ²	
			Standard Fit-up	PWGSC/Client		FAH (BMP/WPM) or SSA ³
			Other			
		Fit-up of Long Term Space for Reuse (i.e. move back to original location)	Base Building	PWGSC	FAH (BMP/WPM) ²	
			Standard Fit-up	PWGSC/Client	FAH (BMP/WPM) or SSA ³	
			Other			Client

Non-reimbursing Occupancy Instruments (OIs)				
Inventory Impact	Project Description	Fit-up Components (see Fit-up Standards A3.3)	Funding Department	Mechanism for Obtaining Funding*
Space Optimization	Space Expansion Avoidance: Alterations to Existing Accommodation to Increase FTEs	Base Building	PWGSC	FAH (BMP/WPM) with Space Envelope Reduction ^{2,4}
		Standard Fit-up		
		Other	Client	SSA
	Densification: Alterations to Existing Accommodation to Reduce m ² /FTE	Base Building	PWGSC/Client	FAH (BMP/WPM) with Space Envelope Reduction or SSA ^{2,3}
		Standard Fit-up		
		Other	Client	SSA
Forced Move by PWGSC	Fit-up for Initial Occupancy or Fit-up of Existing Space for Reuse	Base Building	PWGSC	FAH (BMP/WPM) ^{2,5}
		Standard Fit-up		
		Other		

¹ PWGSC assumes the costs for moving of screens and standard furniture, as required to implement cyclical maintenance (e.g. for carpet replacement). Client department pays for dismantling, moving and reassembling of computers, telecommunications and other specialized equipment and furnishings, as required and when provided with sufficient notification to program the required funds.

² For leased facilities, base building components are funded by the landlord as negotiated in the lease contract.

³ Funding accountabilities are determined on a case by case basis in agreement with client department.

⁴ Payback period of total project cost must justify the investment.

⁵ PWGSC will replace like-for-like conditional on compliance with Fit-up Standards.

* Refer to R1 Glossary for definitions.

Reimbursing and Expansion Control Framework (ECF) Occupancy Instruments (OIs)					
Inventory Impact		Project Description	Fit-up Components (see Fit-up Standards A3.3)	Funding Department	Mechanism for Obtaining Funding*
Existing OI	During Term of Occupancy	Tenant Services: Alterations to Existing Accommodation	Base Building	Client	SSA
			Standard Fit-up		
			Other		
		Cyclical Maintenance: Repair or Replacement	Base Building	PWGSC	FAH (BMP/WPM) ^{1,2}
			Standard Fit-up	Client	SSA
			Other		
New OI	Same Location: OI Renewal or OI & Lease Renewal (with or without a space reduction)	Tenant Services: Alterations to Existing Accommodation	Base Building	Client	SSA
			Standard Fit-up		
			Other		
		Cyclical Maintenance: Repair or Replacement	Base Building	PWGSC	FAH (BMP/WPM) ^{1,2}
			Standard Fit-up	Client	SSA
			Other		
	New Location: Expansion or Replacement	Fit-up for Initial Occupancy or Fit-up of Existing Space for Reuse	Base Building	PWGSC	FAH (BMP/WPM) ²
			Standard Fit-up	Client	SSA
			Other		
	Major Renovations by PWGSC	Fit-up of Swing Space for Initial Occupancy or for Reuse	Base Building	PWGSC	FAH (BMP/WPM) ²
			Standard Fit-up		
			Other		
		Fit-up of Long Term Space for Reuse (i.e. move back to original location)	Base Building	PWGSC	FAH (BMP/WPM) ²
			Standard Fit-up	Client	SSA
			Other		
	Major Renovations by PWGSC & Client Department	Fit-up of Swing Space for Initial Occupancy or for Reuse	Base Building	PWGSC	FAH (BMP/WPM) ²
			Standard Fit-up	PWGSC/Client	FAH (BMP/WPM) or SSA ³
			Other		
		Fit-up of Long Term Space for Reuse (i.e. move back to original location)	Base Building	PWGSC	FAH (BMP/WPM) ²
			Standard Fit-up	Client	SSA
			Other		
	Space Optimization	Space Expansion Avoidance: Alterations to Existing Accommodation to Increase FTEs	Base Building	Client	SSA
			Standard Fit-up		
			Other		
Densification: Alterations to Existing Accommodation to Reduce m ² /FTE		Base Building	Client	SSA	
		Standard Fit-up			
		Other			
Forced Move by PWGSC	Fit-up for Initial Occupancy or Fit-up of Existing Space for Reuse	Base Building	PWGSC	FAH (BMP/WPM) ^{2,4}	
		Standard Fit-up			
		Other			

¹ PWGSC assumes the costs for moving of screens and standard furniture, as required to implement cyclical maintenance (e.g. for carpet replacement). Client department pays for dismantling, moving and reassembling of computers, telecommunications and other specialized equipment and furnishings, as required and when provided with sufficient notification to program the required funds.

² For leased facilities, base building components are funded by the landlord as negotiated in the lease contract.

³ Funding accountabilities are determined on a case by case basis in agreement with client department.

⁴ PWGSC will replace like-for-like conditional on compliance with Fit-up Standards.

* Refer to R1 Glossary for definitions.

A3.3 Fit-up Components and Funding Accountabilities

The following chart identifies components that may be part of a fit-up project. Funding accountabilities for the components are as follows:

- Base building components are funded by PWGSC;
- *Workplace 2.0 Fit-up Standards* components for non-reimbursing clients are funded by PWGSC;
- *Workplace 2.0 Fit-up Standards* components for reimbursing clients and Expansion Control Framework are funded by the client department or agency;
- Other components, including security requirements, are funded by the client department or agency, including all related commissioning, testing and ongoing maintenance.

Alterations to existing accommodation carried out during the term of an occupancy (i.e., tenant services), are funded by the client department.

Note: If a client department continues to occupy the same space after renewal of an occupancy instrument or lease, fit-up activities would not be undertaken. Any alterations required at that time to meet changes to the client's operational requirements would be provided as a tenant service. However, standard finishes (e.g., carpet, screen fabric, painted surfaces) may be replaced, repaired or refreshed at PWGSC cost if required as a result of normal wear and tear – generally after a period of 10 to 12 years.

Components		Base Building	Fit-up Standards	Other
A	Building Site Work			
	(a) Site preparation, site improvements, utility tunnels, site utilities (including communication media access).	Yes		
	(b) Primary identification signage (building), flagpole and base.	Yes		
	Additional site work and site improvements increased utility requirements, etc.			Yes ¹
B	Substructure			
	1. Foundations and basements including slab on grade	Yes		
	Alteration to suit client requirements (e.g., addition of window wells).			Yes ¹
C	Shell			
	1. Suspended floor slabs and roof structure	Yes		
	Alteration to suit client requirements (e.g., to increase loading capacity, add stairs).			Yes ¹
	2. Exterior closure, including walls, windows, doors and roofing	Yes		
	Alteration to suit client requirements.			Yes ¹

Components		Base Building	Fit-up Standards	Other
D	Interior Construction			
	1. Walls			
	(a) Building core, shear and shaft walls (stairwells, utility spaces).	Yes		
	(b) Demising walls, multiple-tenant floors and crossover floors – constructed to meet current Building Code requirements.	Yes		
	Additional demising wall treatments to meet client security requirements (e.g., wire mesh, security grills in ductwork) and related ongoing maintenance.			Yes ²
	(c) Partition walls – in addition to traditional metal or wood frame construction, reusable partition systems (e.g., movable, demountable) are acceptable within the Workplace 2.0 Fit-up Standards and, as such, can be used to provide enclosed office and support space. These systems need to be reusable and flexible (e.g., capacity to modify one element with minimal disruption to the rest of the wall system). Such systems shall be considered as an option for partitions when they can meet client program requirements and provide the best environmental and economic value to the Crown. (See part F for furniture screens/panels)			
	(i) Closed offices <ul style="list-style-type: none"> Director, DG and ADM level – slab to underside of ceiling with insulation and plenum barriers (enhanced speech privacy, approximates STC 45³). 		Yes	
	<ul style="list-style-type: none"> All other closed offices, e.g., senior departmental representative in regional offices – slab to underside of ceiling with insulation and plenum barriers (enhanced privacy, approximates STC 45). 		Yes	
	<ul style="list-style-type: none"> ADM offices requiring secure speech privacy, as determined by a Threat and Risk Assessment (TRA) – slab-to-slab construction with insulation, (approximates STC 52). 			Yes ²
	(ii) Support spaces <ul style="list-style-type: none"> Storage rooms, shared equipment areas, kitchenettes and similar functions – slab to underside of ceiling with insulation (standard speech privacy approximates STC 35). 		Yes	
	<ul style="list-style-type: none"> Meeting, training, quiet rooms and similar functions – slab to underside of ceiling with insulation and plenum barriers (enhanced speech privacy, approximates STC 45). 		Yes	
	<ul style="list-style-type: none"> Telecommunications rooms – slab to underside of ceiling with insulation and plenum barriers (see A4.1). 	Yes		
	<ul style="list-style-type: none"> Retractable or folding partition walls to create two medium meeting rooms from one large meeting room (see A6.2). 		Yes	
	<ul style="list-style-type: none"> Other retractable or folding partition walls Note: The project team technical experts should ensure due diligence with regards to product selection and advise the client accordingly of the pros and cons to consider. 			Yes ²
	(iii) Glazing treatments <ul style="list-style-type: none"> Treated sidelights and clerestory glazing (single pane) with optional film as illustrated in A6.3. 		Yes	
	<ul style="list-style-type: none"> Glazing in reusable partition systems where there is no additional cost. Note: Glazing treatments are not recommended when speech privacy is a priority. 		Yes	

Components	Base Building	Fit-up Standards	Other
Additional partition walls to create separate secure zones or additional partition wall treatments (e.g., wire mesh, security grills in ductwork) to meet client security requirements, and related ongoing maintenance. Note: This does not include the creation of additional individual closed offices or support spaces.			Yes ²
Other additional partition walls or special construction and related maintenance, e.g., slab-to-slab construction for meeting rooms equipped with video conference systems.			Yes ¹
2. Doors and frames			
<i>(a) Demising wall doors (e.g., suite entry/egress door) – partially glazed to facilitate orientation and safe movement.</i>	Yes		
<i>(b) Partition wall doors</i> (i) Flush solid core wood doors – standard height and width (6'-8" or 7'-0" x 3'-0") wood veneer or paint finish. (Transfer grills are provided on telecommunication room doors if required.)		Yes	
(ii) Wood or steel frames – natural (stain) or paint finish. Note: Where security is a factor, pressed steel frames are recommended, e.g., telecommunications rooms		Yes	
(iii) "Vision ports" or glazing inserts in doors.		Yes	
(iv) Fire-rated doors and frames as required by code.		Yes	
(v) Sliding doors – may be acceptable where there is no additional cost. Sliding doors must meet National Building Code requirements to ensure safe egress from enclosed spaces without restricting access to exits.		Yes	
(vi) Dutch doors – to address special requirements for service counters, cashier's offices, etc. The height of the separation between the upper and lower doors must be between 730 mm – 860 mm to meet accessibility requirements.			Yes ²
Additional door and frame types or treatments to meet client security requirements.			Yes ²
Other door and frame sizes or types or additional treatments to suit client requirements.			Yes ¹
3. Door hardware			
<i>(a) Mortise (keyed) lock set (with two sets of reproducible keys) and lever trim (handle) on suite entry doors.</i>		Yes	
<i>(b) Cylinder latch or keyed lock set (with two sets of reproducible keys) and lever trim (handle) on all other room doors.</i>		Yes	
<i>(c) Dummy levers on closet doors.</i>		Yes	
<i>(d) Door closers as required by building code.</i>		Yes	
<i>(e) Additional hardware, as required, for durability in high traffic areas, e.g., push/pull and kick plates.</i>		Yes	
<i>(f) Accessibility hardware on base building doors to meet CAN/CSA B651 04 (or latest version) Technical Standard.</i>	Yes		
Additional accessibility (Duty to Accommodate) or security hardware and related ongoing maintenance.			Yes ²
Additional door hardware and related ongoing maintenance.			Yes ¹

Components	Base Building	Fit-up Standards	Other
4. Interior specialties			
(a) <i>Washrooms</i> (i) Core washroom fixtures, compartments, counters and dispensing accessories to meet base building standards.	Yes		
(b) <i>Cabinetry and millwork</i> (i) Counters and/or storage cabinets in kitchenettes and shared equipment areas as allocated in A3.4 and illustrated in A6.2 – custom grade construction or modular units (at comparable cost). Finishes to suit application and respect criteria outlined in A7.1.		Yes	
(ii) Service counters and carrels in public contact spaces only (construction and finishing as above).			Yes ²
(iii) Kiosks for public contact spaces.			Yes ²
(iv) Primary reception counter.			Yes ²
(v) Coat closet – rods and shelves as allocated in A3.4.		Yes	
(vi) Storage shelving, etc., (including high-density mobile systems).			Yes ²
Additional interior specialties and related ongoing maintenance (e.g., additional millwork, modifications to base building washrooms).			Yes ¹
5. Interior finishes (see A7)			
(a) <i>Building core areas</i> (i) Wall, floor, ceiling and base treatments to core areas, main entrance, lobbies and other base building support areas.	Yes		
(b) <i>Office and support areas</i> (i) Ceiling finishes • Base building standard (typically acoustic tile).	Yes		
• Bulkheads as required to suit mechanical design or other site constraints.	Yes	Yes	
(ii) Floor finishes • Typically carpet (rolled goods or carpet tile), resilient sheet or tile, ceramic tile or “unfinished” (sealed concrete) to suit function of space.	Yes		
• Modifications to base building floor finishes to enhance way finding and durability in major circulation paths (carpet inserts) maximum 10% of floor area unless using carpet tile.		Yes	
• Antistatic floor treatments in LAN rooms.			Yes ²
• Raised floor systems and ramps, epoxy or other special treatments to suit client requirements.			Yes ²
(iii) Wall/base finishes • Exterior perimeter walls and columns (to meet base building standard).	Yes		
• Partitions (paint or unfinished to suit performance requirements and substrate, limited use of wall coverings as required in high traffic areas only).		Yes	
• Wall base treatment to suit flooring.	Yes	Yes	
• Tackable/acoustical wall treatment on interior of meeting rooms.			Yes ²
Additional finishes and related ongoing maintenance.			Yes ¹

Components		Base Building	Fit-up Standards	Other
E	Services			
	1. Conveying systems			
	(a) Vertical transportation, finished elevators and escalators (if existing in building).	Yes		
	(b) Keyed access, additional doors, private elevators.			Yes ¹
	Additional systems or modifications and related ongoing maintenance.			Yes ¹
	2. Plumbing systems			
	(a) Basic building and core area services, including regular and accessible plumbing fixtures, drinking fountains, domestic water, sanitary waste and rainwater systems (does not include hard plumbed water coolers).	Yes		
	(b) Stainless steel sink(s) in kitchenettes complete with hot and cold water, insulation, drain and vent piping.		Yes	
	(c) Washrooms (in addition to base building washrooms) for the exclusive use of the client, including all related fixtures and services.			Yes ¹
	(d) Washrooms/showers required as part of TBS approved departmental program requirement only – fixtures to match base building quality.			Yes ²
	(e) Common shower facilities (TB Workplace Fitness Policy applies).			Yes ²
	(f) Relocate/add drinking fountains to suit planning requirements.		Yes	
	Additional systems and related ongoing maintenance.			Yes ¹
	3. Heating, ventilation and air-conditioning systems			
	(a) Basic building and core area systems, including fuel supply, heat generation, rejection, distribution and transfer systems, controls, testing and balancing.	Yes		
	(b) Main trunk ductwork, branch ductwork, base building terminal units, controls and base building distribution.	Yes		
	(c) Relocate and/or add, ductwork, terminal units (VAV boxes, fan coil units, etc.), diffusers, controls, including systems testing and balancing (to meet latest ASHRAE standards 55 and 62) (see A.6 for thermostat control).		Yes	
	(d) Meeting/training rooms, public service area, kitchenette and shared equipment area ventilation – add/relocate terminal units (VAV boxes, fan coil units) recirculating fans or A/C units including associated controls (see A.6).		Yes	
	(e) Separate continuous 24/7 cooling in telecommunications rooms and equipment room to meet environmental conditions specified in TIA-569-B (for new major retrofit or new construction or new major lease buildings) (see A.4).	Yes		
	(f) Controls and monitoring – relocate and/or add thermostats, valves, sensors, terminal unit controller (VAV boxes, fan coil units control) control points, etc.		Yes	
	Additional systems and related ongoing maintenance (e.g., additional or separate air conditioning for server or UPS rooms).			Yes ¹
	4. Fire protection systems			
	(a) Sprinkler, standpipe and hose systems (all areas), fire extinguishers.	Yes		
	(b) Relocate/add sprinkler heads and hose systems to suit layout.		Yes	
	(c) Heat detectors, smoke detectors as required by code.		Yes	

Components	Base Building	Fit-up Standards	Other
<i>(d) Additional fire extinguishers as required by code.</i>		Yes	
Additional fire protection systems and related ongoing <i>maintenance</i> (e.g. <i>electronic card swipe entry systems</i>).			Yes ¹
5. Electrical systems			
<i>(a) Power</i>			
<i>(i) Service, distribution and emergency (life safety) building power (including main and floor level electrical rooms).</i>	Yes		
<i>(ii) Relocate/add power circuits (typically one-circuit/two workstations) receptacles, conduits and raceways to suit function and layout (to meet the standards outlined in the "Design Guideline – Powering General Office Spaces").</i>		Yes	
<i>(iii) Dedicated circuits and other specific requirements in support spaces as illustrated in A6.2.</i>		Yes	
<i>(iv) UPS, "clean" power and other dedicated circuits for client operational requirements.</i>			Yes ²
<i>(v) Generator for client's operational requirements.</i>			Yes ²
<i>(vi) Enhanced accessibility measures (e.g., visual alarm systems, etc.) – Duty to Accommodate.</i>			Yes ²
<i>(b) Lighting</i>			
<i>(i) Lighting and power distribution to core and open office areas.</i>	Yes		
<i>(ii) Modifications to base building fixtures.</i>			Yes ¹
<i>(iii) Relocate/add base building lighting to suit function and layout.</i>		Yes	
<i>(iv) Lighting modifications to suit meeting room functions as illustrated in A6.2.</i>		Yes	
<i>(v) Task lighting.</i>			Yes ²
<i>(vi) Additional lighting and power for special client needs including video conference services, etc.</i>			Yes ¹
<i>(c) Controls and monitoring</i>	Yes		
<i>(i) Controls and instrumentation (e.g., computerized switching, energy monitoring and control systems).</i>			
<i>(ii) Modify controls and/or instrumentation to suit layout or monitoring requirements (e.g., separate switching of closed offices, meeting rooms etc. or monitoring the energy consumption of a particular function or group). The use of motion sensor lighting controls is required.</i>		Yes	
<i>(iii) Critical level and advanced controls for special client requirements (e.g., specialized control systems for computer room).</i>			Yes ²
<i>(d) Fire alarm systems</i>			
<i>(i) Fire alarm with detectors, bells, pull stations, voice communication and annunciators.</i>	Yes		
<i>(ii) Relocate/add fire alarm points to suit office layout.</i>		Yes	
<i>(e) Sound masking systems</i>		Yes	
<i>(i) Sound masking system to suit office layout.</i>			
Additional electrical systems, infrastructures and related ongoing maintenance.			Yes ¹

Components	Base Building	Fit-up Standards	Other
6. Telecommunications Systems (see A4.1)			
(a) <i>Spaces and pathways</i>			
(i) Shared Entrance Room, Common Equipment Room, Equipment Room and Telecom Rooms.	Yes		
(ii) In leased buildings also housing non-GC occupants, Common Telecommunications Rooms as required.	Yes		
(iii) Dedicated Equipment Room or Telecom Room.			Yes ¹
(iv) Generic backbone (also called "vertical" or "riser"), pathways (such as conduit, cable tray and sleeves) connecting Telecom Room(s) on each floor to the Equipment Room and connecting the Equipment Room to the Entrance Room and/or Common Equipment Room.	Yes		
(v) Dedicated backbone pathways requested by the client.			Yes ¹
(vi) Generic horizontal raceways (such as cable tray or conduit) from Telecom Room(s) on each floor. "J-hooks" may be used when the Crown has only a short-term interest in the space.	Yes		
(vii) Service poles for workstations and conduit in partitions for image, voice and data outlets. Note: Separate poles may be required for voice and data.		Yes	
(viii) Additional telecommunications infrastructure.			Yes ¹
(b) <i>Cabling</i>			
(i) Generic backbone cabling (vertical and to connect multiple telecommunications rooms on the same floor).	Yes		
(ii) Horizontal cabling and jacks for voice, data, image.			Yes ²
Telecommunication equipment such as rooftop dishes, satellite or microwave and antennas.			Yes ²
Additional telecommunications systems and infrastructures.			Yes ¹
7. Security			
(a) <i>Base building security (lockable exterior entrances, perimeter and vehicle controls if applicable, main level entry control).</i>	Yes		
Additional security systems including infrastructure and related ongoing maintenance.			Yes ²
F Furnishings and Equipment			
(a) <i>Window coverings</i>			
(i) Exterior window coverings (to base building specification).	Yes		
(ii) Security film to exterior windows.			Yes ²
(iii) Additional treatments to exterior windows.			Yes ¹
(iv) Treatments to interior glazing (e.g., blinds and drapes) other than as illustrated in drawing examples (film) and noted in part D1C (iii).			Yes ¹
(b) <i>Furniture and equipment</i>			
(i) Panels or screens complete with service poles (midrange quality component system, non-acoustic class with power or data capability) (see A3.5).		Yes	
(ii) Integrated and mobile furnishings including horizontal components (work surfaces, tables, cabinets, storage pedestals), personal storage towers dividers, chairs, task lights, etc.			Yes ²

Components		Base Building	Fit-up Standards	Other
	(iii) Telephone equipment, computers, photocopiers, fax machines, etc.			Yes ²
	(iv) Visual aid boards including white boards, bulletin boards etc. (including installation).			Yes ²
	(c) <i>Signage and accessories</i>	Yes		
	(i) Common use signs including the main (lobby area) directory, fire exiting routes, etc.			
	(ii) Operational signage based on the operational requirements of the client including directional and location signs, name plates, informational signs, etc.			Yes ²
	(iii) Plants, planters and related ongoing maintenance.			Yes ²
	(iv) Artwork.			Yes ²

¹ Client cost – subject to the non-compliance approval process (see A2).

² Client cost – NOT subject to the non-compliance approval process. Security requirements must be based on a Threat and Risk Assessment (TRA), Security Design Brief or Security Site Brief, signed off by the Departmental Security Office (DSO) and properly documented on the project file.

³ The Sound Transmission Class (STC) rating is a single-number rating of an assembly's ability to resist airborne sound transfer. STC ratings are based on a laboratory test that does not take into consideration weak points or penetrations. Site conditions may make it difficult to achieve the complete rating.

A3.4 Office and Support Space Allocations

The following notes and tables summarize allocations for standard office and support spaces.

Office Space

Workplace 2.0 principles are based on the functional requirements of workers and allocate space based on the amount of time spent in the workplace. Studies have shown that employees only utilize their dedicated space from 40-60% of the time, leaving nearly half of their real estate vacant at any one time. Based on research of the amount of time employees spend at their workstations, four worker profiles have been established.

Leadership: 10 m² – maximum of 18.5 m².

Leadership workers can be allocated an enclosed office but it is not mandatory and it is an allowance not an entitlement. Examples: Director, Director General or higher.

Fixed: maximum of 4.5 m².

Employees who are at their desk more than 60% of the day. Examples: Policy Analyst, Administrative Assistant, Call/Contact Centre operator, translator.

Flexible: maximum of 3.0 m².

Employees who are at their desk approximately 40% of the day. Examples: Account executive, Auditor, part-time teleworker, inspector.

Free Address: maximum of 1.5 m².

The nature of the employees' work does not require them to have an individual dedicated workstation in the office. They will generally only drop in for short amounts of time on a periodic basis to meet with colleagues, catch up on projects or simply make social connections. Examples: Consultants, remote workers, regional employees, full-time teleworkers. It should be noted that the free address workstations are not assigned to any specific employee.

Open Workstations

Open workstations, adaptable to team or individual configurations, are assigned to all personnel in an open-plan office environment (except free address personnel).

Workstations may vary in size up to a **maximum** of 4.5 m². The actual dimensions and configuration will depend upon specific site conditions, functional requirements of the users and availability of space. The reduced amount of space used for individual workstations provides clients with the flexibility to create collaborative, teaming and open meeting spaces.

The size and number of panels/screens used to define a workstation will vary. See A3.5 Standards for Furniture Panels/Screens for information on panel/screen standards, and A5.1 for planning applications.

See A6.1 Workstations, Collaborative and Enclosed Spaces for drawings that illustrate the typical sizes and configurations of workstations, including descriptions of standard finishes and mechanical and electrical provisions.

Enclosed Offices

The following table summarizes provisions for enclosed offices for various positions.

Note: These office sizes are **maximum allowances, not entitlements**. The assignment and size of enclosed offices must be considered within the context of the total project, functional requirements of the users and the *Space Allocation Standards* of the *Framework for Office Accommodation and Accommodation Services*. Consideration must always be given to the potential to meet requirements in less space.

Function	Maximum Area (m ²)
EX-5 and EX-4 positions and equivalents ¹ (e.g., ADMs, members of boards, commissions and councils)	18.5
EX-3, and EX-2 positions and equivalents ¹ (e.g., directors general) EX-1 positions and equivalents ¹ no more than 3 levels below the DM or Associate DM (e.g., directors)	14.0
Other EX-1 positions and equivalents with 10 or more funded reports (where space allows) Senior departmental representatives (the most senior position at small regional offices or remote locations), lawyers, ICMS ²	10.0

¹ EX equivalents are defined in the Treasury Board Secretariat's Values and Ethics Code for the Public Service listing (2004-01-27) <http://www.tbs-sct.gc.ca/gui/intcd04-eng.asp>.

² Positions within the Law (LA) Occupational Group engaged in the practice of law as well as Informal Conflict Management System (ICMS) employees providing conflict management service. Departments are encouraged to use their Undesignated Support Space allocation, whenever possible, for LA and ICMS employees. If the requirement cannot be met within the provisions of the *Workplace 2.0 Fit-up Standards* support space allocations, departments may elect to provide an additional enclosed office for this employee and note the requirement in the project file.

* **Note:** For the LA and ICMS positions, client departments fund the difference between the cost of a workstation and an enclosed office, including fit-up, rent and related ongoing maintenance.

The minimum enclosed office size is 10 m² (10' x 10') or as dictated by the building module.

Note: For offices of this size, furniture may need to be located along the wall to provide the necessary turning radius to ensure accessibility, if required. See A6.1 Workstations, Collaborative and Enclosed Spaces for sample layouts.

See R2 for examples of possible office assignments.

Offices are to be located on the interior unless building conditions do not allow. Requests to locate offices for EX-3 positions and below along the perimeter would generally be considered non-compliant. Locating offices for ADMs on the interior is also strongly encouraged, however, placing them along a window would not be considered non-compliant.

See A6.1 Workstations, Collaborative and Enclosed Spaces for drawings that illustrate typical sizes and configurations of enclosed offices including descriptions of standard finishes and mechanical and electrical provisions.

Support Spaces

Keeping in mind the general principles of consistency (common look and feel) and flexibility, the allocation of all support space functions should relate to the population of each floor (i.e., making each floor as “generic” as possible so the spaces can endure multiple tenants with minimum modifications). It is expected the size of spaces and the quantity of millwork identified for support spaces could vary by up to 15% (larger or smaller than the sizes shown) to suit the specific site conditions and program requirements.

Hard Walled Support Spaces

Meeting Rooms

Meeting rooms provide enclosed spaces for meetings, presentations and collaborative work. The following table summarizes provisions for meeting rooms for various population ranges on a floor.

# of FTEs per floor	Size of Meeting Room			Total
	Small 14 m ² seats 6	Medium 30 m ² seats 12	Large 60.0 m ² seats 20+	
5 – 9	1	–	–	1
10 – 25	–	1	–	1
26 – 50	1	1	–	2
51 – 70	2	1	–	3
71 – 100	2	2	–	4
101 – 137	1	2	1*	4
138 – 175	2	2	1*	5
176 – 225	4	2	1*	7
226 – 250+	4	3	1*	8

* The large meeting room consists of 2 medium sized meeting rooms divided by a retractable wall to maximize flexibility.

A larger meeting room may be “substituted” in place of multiple smaller meeting spaces (e.g., 1 medium in place of 2 small or 1 large in place of 1 medium and 2 small). However, if required, the larger area must be easily convertible back to the smaller rooms at minimal cost and with no additional impact on the space. Decisions of this kind should be considered as part of the initial project identification phases and documented accordingly in the project files. See A6.2 Support Spaces for drawings that illustrate typical sizes and configurations of meeting rooms, including descriptions of standard finishes, lighting modifications, and mechanical and electrical provisions.

Quiet Rooms

These are spaces intended for the shared use of personnel who normally occupy open workstations. They provide an enhanced acoustical environment for a private telephone call, to support work requiring a high level of concentration, or similar functions. The following table summarizes provisions for quiet rooms for various population ranges:

# of FTEs per floor	# of 5 m ² spaces
10 – 45	1
46 – 91	2
92 – 137	3
138 – 183	4
184 – 229	5
230 – 250+	6

See A6.2 Support Spaces for a drawing that illustrates the typical provisions for quiet rooms including descriptions of standard finishes and mechanical and electrical provisions.

Kitchenettes

The sample plans in A5 illustrate some typical configurations of these spaces sized, in each case, to suit the population they serve. Larger kitchenette areas shall be designed to accommodate multiple functions and shall be usable as informal meeting, work or resource areas as well as coffee/lunch facilities and recycling centres. Similarly, where populations warrant multiple provisions, it may be appropriate to have one main and one secondary facility (e.g., one 50 m² kitchenette or multiple function area and one 10 m² "coffee station").

Kitchenette areas may be open or semi-enclosed but entrance doors are not provided.

The following summarizes provisions for kitchenettes for various population ranges:

# of FTEs per floor	# and size of areas	lin. mm of counter and upper/lower storage in each area
2 – 4	one 3 m ²	1,500 (5')
5 – 25	one 10 – 20 m ²	2,400 (8')
26 – 50	one 20 – 30 m ²	3,000 (10')
51 – 100	one 30 – 40 m ²	3,600 (12')
101 – 137	one 40 – 50 m ²	4,200 (14')
138 – 175	one 50 – 60 m ²	4,800 (16')
176 – 225	one 60 – 70 m ²	5,400 (18')
226 – 250+	one 70 – 80 m ²	6,000 (20')

See A6.2 Support Spaces for a drawing that illustrates the typical provisions for a kitchenette including descriptions of standard finishes and mechanical and electrical provisions.

Shared Equipment Areas

Shared equipment areas may be open or semi-enclosed but entrance doors are not provided. The following summarizes provisions for shared equipment areas for various population ranges:

# of FTEs per floor	# and size of areas	lin. mm of counter and upper/lower storage in each area
1 – 4	one 5 m ²	1,800 (6')
5 – 25	one 5 – 10 m ²	1,800 (6')
26 – 50	one 10 – 14 m ²	2,400 (8')
51 – 75	one 14 – 20 m ²	3,000 (10')
76 – 100	two 10 – 14 m ²	2,400 (8')
101 – 150	two 14 – 20 m ²	3,000 (10')
151 – 175	three 10 – 14 m ²	2,400 (8')
176 – 225	four 10 – 14 m ²	2,400 (8')
226 – 250+	three 14 – 20 m ²	3,000 (10')

See A6.2 Support Spaces for a drawing that illustrates the typical provisions for a shared equipment area including descriptions of standard finishes and mechanical and electrical provisions.

Reception Waiting Areas

Primary, hard walled reception areas are only provided on one floor of a large multiple floor occupancy. Secondary reception areas take the form of a workstation on each floor equipped with a surface to receive and distribute mail and a small waiting area to accommodate some seating. This area may also accommodate coat storage and some display related to the business of the particular group(s) at that location.

Other Undesignated Support Space

All other support functions requiring enclosed spaces must be accommodated within 10 m² areas; sized, built and serviced (power and telecommunications) to accommodate office, meeting or other functions either initially or in the future. For higher populations, the space allowances may be combined to create larger areas, as required, (20 m², 40 m², etc.) as long as the larger room could be easily converted back to the smaller rooms at minimal cost and with no additional impact on the space if required in the future. The amount of Undesignated Support Space can be planned based on total occupancy but allocated by FTE per floor to ensure consistency and flexibility for future occupancies.

Undesignated Support Space must first be used to satisfy the requirements of true non-compliant support spaces (e.g. storage, file room, etc.) before being allocated to any proposed enclosed offices.

The allowances for other undesignated hard walled support spaces are as follows:

# of FTEs per floor	# of 10 m ² spaces
3 – 50	1
51 – 110	2
111 – 175	3
176 – 250+	4

Other support functions include but are not limited to:

- ◆ storage and file rooms;
- ◆ resource rooms and libraries;
- ◆ server/LAN rooms (special mechanical provisions, if required, are client responsibility);
- ◆ breakout rooms; and
- ◆ additional quiet rooms (two per undesignated support space allowance).

Open Area Support Spaces

Collaborative Spaces

With the changing nature of work and the continued importance of team-based activities and projects, the inclusion of collaborative spaces in the *Workplace 2.0 Fit-up Standards* is a very important element to encourage teamwork and idea sharing. Collaborative spaces provide a place to go for quick informal or team meetings, brainstorming and problem solving sessions without having to book a meeting room, thereby saving time and increasing productivity. Collaborative spaces can also provide touch down spots for clients and teleworkers or just an area for employees to socialize. Collaborative spaces can include flexible furniture that can be arranged in any required configuration and more than one team can use the space at the same time.

The planning ratio for the collaborative areas is to be calculated based on a minimum of 5-10% of the floor area.

In addition to the collaborative spaces, clients may choose to incorporate other shared support spaces into open areas as long as the *Space Allocation Standards* of the *Framework for Office Accommodation and Accommodation Services* is not exceeded. Open area support spaces could include supplementary equipment areas, file areas, layout spaces, resource areas, etc. The regular workstation configurations are substituted by the appropriate furnishings to support the desired function.

Careful consideration should be given to the amount of space allocated for general filing. Off-site storage and/or electronic filing systems are preferred for records storage.

Printer Stations

In addition to the centrally located, shared equipment areas, stations can be provided throughout the office for access to network printers if required. With the advent of large multi-function printer units the full allocation may not be necessary.

Power and data services are provided to each location. There is no millwork allowance for these spaces and the client is responsible for the provision of furniture and equipment.

Planning ratio: maximum of one printer station for every 20 – 30 FTEs.

Coat Storage

Coat closets may be provided for visitors and are to be conveniently located. Approximately 100 mm of hanging space is required for each coat/person or one 1.5 m (5'-0") closet for every 15 visitors.

First Aid Room or Station

A first-aid room is not required where a health unit or a similar emergency treatment facility is conveniently available to provide first-aid services. As a result, first aid rooms are seldom justifiable and have been removed from many locations. Refer to Treasury Board Policy [Operational Health and Safety Directive, Section 18.6, First-aid Rooms](#). If required, the planning ratio is as follows:

Planning ratio: 1 per 200 or more FTEs.

A3.5 Standards for Furniture Panels/Screens

Panels may be used to provide visual privacy in open-plan office environments. Panels shall meet the requirements of CAN/CGSB-44.229 and the *Purchase Description for Interconnecting Panels and Supported Components* published by the Acquisitions Branch. The following additional restrictions apply to panel height, classification and finish options as well as power/voice/data receptacles. See A5.1 for planning and Workplace 2.0 design principles.

Height

The maximum height for panels is 1.37 m (54"). Lower panels allow for increased light distribution and airflow and provide seated privacy. Panels that exceed 1.37 m (54") are considered non-compliant.

Classification

Panels shall be non-acoustic class. High performance acoustical panels do **NOT** comply with the Standards.

Finish

Panel finish can be fabric upholstered, perforated metal, veneers (wood and plastic laminate) as long as there is no cost differential. All materials shall be manufactured from recycled or other environmentally appropriate materials that respect the selection criteria identified in A7, unless reusing or matching existing panels. Glass panels with a maximum height of 38 cm (15") are allowed but the overall maximum screen height cannot be exceeded. Fully glazed panels and sliding panels do **NOT** comply with the standards.

Clients may also purchase accessory items such as mobile whiteboards or add-on translucent or mesh dividers/toppers to create visual privacy with lower screen heights (the maximum screen height cannot be exceeded).

Power/Voice/Data Receptacles

Each workstation is provided with three duplex power outlets (6 receptacles) and one voice/data outlet. Refer to typical workstation layouts in A6 for additional information.

Note: The *Purchase Description for Interconnecting Panels and Supported Components* specifies the minimum components and capabilities of the electrical system. Federal employees occupy many buildings where these standard electrical system capabilities (power/voice/data) cannot be fully realized due to the limitations of the base building systems. This does NOT imply that the base building infrastructure should be renovated to accommodate the furniture system capabilities. Therefore, the final electrical design shall not exceed the capacity of the base building infrastructure.

A4. Special Technical Standards

A4.1 Telecommunications Infrastructure

Overview

The telecommunications infrastructure in an office building is described and specified in *“Commercial Building Standard for Telecommunications Pathways and Spaces,”* TIA-569-B. The *Workplace 2.0 Fit-up Standards* apply this standard.

Figure 1 below illustrates the telecommunications infrastructure of spaces and backbone pathways in a typical Crown-owned building, or one where all the space is leased by the Crown. It follows a “holistic” approach to the telecommunications infrastructure design by looking at the building as a single entity, regardless of whether it is occupied by one or several departments, similar to how other utilities are distributed.

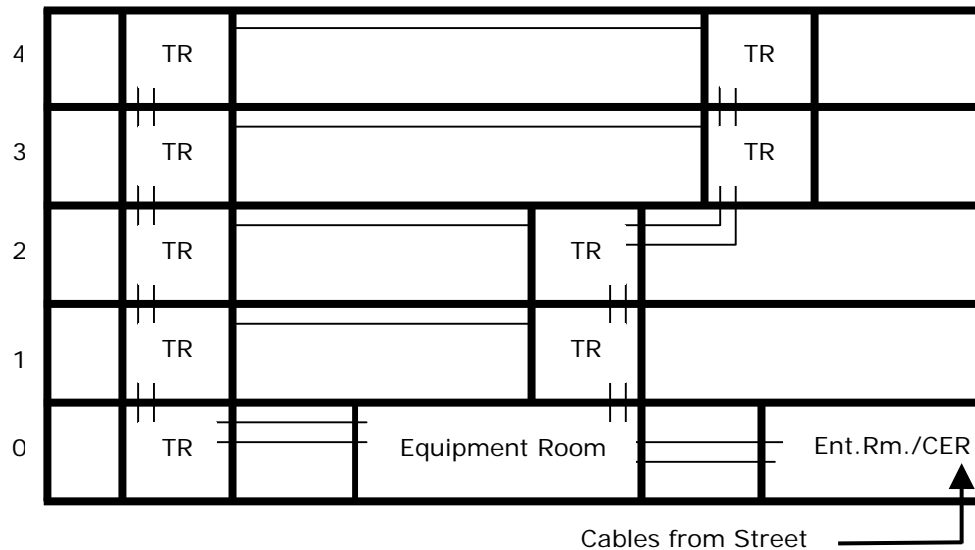

Figure 1: Telecommunications Spaces and Pathways in Crown-owned Building

- Ent. Rm: Entrance Room
- CER: Common Equipment Room
- TR: Telecommunications Room

The infrastructure provided by PWGSC is intended to suit the requirements of both the initial department occupying the space, as well as the requirements of any subsequent occupant. This holistic approach facilitates accommodating changes in space. In buildings with more than one department (multi-department buildings), the telecommunications infrastructure will be shared by these departments and each one will have equal access to the infrastructure serving it.

Telecommunications cables of the various telecommunication carriers such as Bell, Telus, Rogers, etc. enter the building from the street and are routed to an Entrance Room where they terminate. The Entrance Room is usually combined with a Common Equipment Room that houses electronic equipment owned by the telecommunications carriers to deliver services to the occupants. The point of demarcation (similar to a “border”) between the facilities owned by the carriers and those owned by the occupants is usually located in this room.

Backbone pathways (e.g. conduit, cable tray) carry cables from the Entrance Room/Common Equipment Room to the Equipment Room. The Equipment Room is the central point for the distribution of telecommunications services within the building. Cables terminate in each of these rooms.

Backbone pathways also carry cables from the Equipment Room to each of the various Telecommunications Rooms located on each floor. The Telecommunications Room is the distribution point of these networks to work areas located in the vicinity. Cables are also terminated in each Telecommunications Room. A backbone pathway and cables link multiple telecommunications rooms on each floor.

Horizontal pathways (not illustrated) typically carry cables from each Telecommunications Room to the vicinity of the work areas being served.

Figure 2 below illustrates the telecommunications infrastructure of spaces and backbone pathways in a typical building where the Crown has leased only some of the available office space. In this example, Government of Canada (GC) space is on floors 3 to 7 inclusive and thick lines are used to separate space occupied by the GC from both space leased to others, as well as the landlord's common spaces.

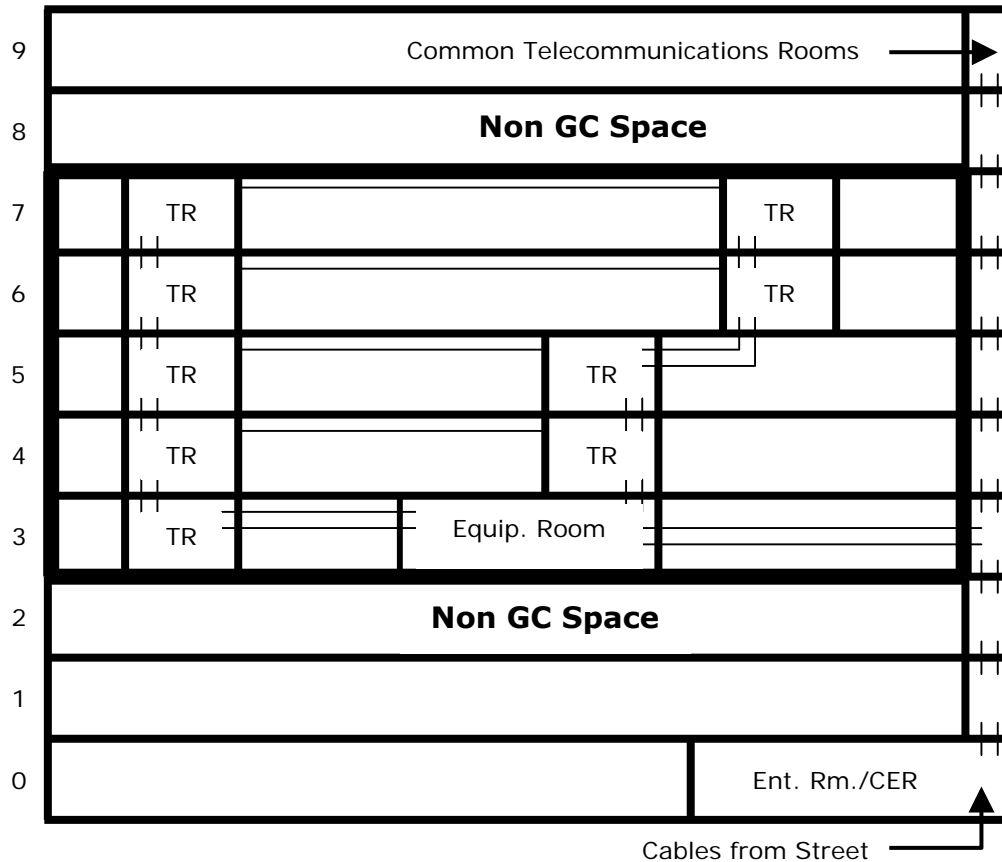

Figure 2: Telecommunications Spaces and Backbone Pathways in Leased Space

Ent. Rm: Entrance Room

CER: Common Equipment Room

TR: Telecommunications Room

As in the typical Crown-owned building (Figure 1: Telecommunications Spaces and Pathways in Crown-owned Building), cables owned by the telecommunications carriers enter from the street and end in an Entrance Room which may also serve as a Common Equipment Room housing electronic equipment owned by the carriers and required by them to deliver their services. Signals of the telecommunications carriers are distributed to the space occupied by each tenant by cables routed through a series of vertically stacked Common Telecommunications Rooms. Note that these rooms are not within the GC leased space.

The construction of telecommunications spaces and backbone pathways within space leased by the GC follows the holistic approach also as shown in Figure 1: Telecommunications Spaces and Pathways in Crown-owned Building. The GC is considered as a single tenant.

Shared Holistic Infrastructure

The holistic (shared) infrastructure of telecommunications spaces and pathways is provided by PWGSC as base-building components. However, this infrastructure is often constructed as part of the fit-up process.

In buildings housing more than one department, the holistic telecommunications infrastructure will be shared by these departments and each one will have equal access to the infrastructure serving it. This access cannot be controlled or hindered by another client department. Although only one department may initially occupy a space, additional departments may occupy it in the future, which requires sharing the infrastructure.

PWGSC considers infrastructure that a department is unwilling to share equally as dedicated to and funded by that department, following approval through the non-compliance process (outlined in A2.3 Process for Approval of Non-compliance).

Telecommunications Rooms

The horizontal and backbone cables end in the Telecommunications Rooms (TR). They also house electronic equipment such as LAN switches required to provide the building's telecommunications networks. While TRs do not normally house LAN servers¹, it may be possible to accommodate a few servers in this space.

Each Telecommunications Room (TR) is to be located as close as possible to the centre of the area being served and preferably in the core area. TRs complying with the requirements of standard TIA-569-B should be sized as follows:

Area Served	Room Size
1,000 m ²	3.3 m x 3 m (11' x 10')
800 m ²	2.8 m x 3 m (9' x 10')
500 m ²	2.2 m x 3 m (7' x 10')

As well, TIA-569-B states that no telecommunications room should serve more than 1,000 m² of floor space.

¹ LAN switches and servers are not the same. A LAN server is a computer that stores and processes information, whereas a LAN switch directs the telecommunications traffic that flows through it.

The use of the non-mandatory word “should” permits some *reasonable* latitude to the knowledgeable designer and is discussed below under some of the sample scenarios. For example, it is most likely that when strategically located, a single Telecommunications Room could serve 1,100 square metres, or possibly somewhat more. As well, the Telecommunications Room may have slightly different dimensions or occupy a floor area that varies somewhat from that specified above.

Equipment Room

The Equipment Room is the central point of telecommunications within the building. Backbone cables terminate here. When sized according to standard TIA-569-B, this room is quite large (0.7% of the floor area served) and should provide ample space to house the servers owned by the client department(s), in addition to the electronic equipment for department’s(s’) internal telecommunications networks. This electronic equipment could include LAN switches, routers, or a telephone switch (PBX).

The RCMP’s Guide G1-031, [*Physical Protection of Computer Servers*](#), supports the shared holistic approach described above and explicitly permits rooms housing servers storing sensitive information (protected or classified) to be shared by different departments. While servers are typically housed in the Equipment Room, it applies to Telecommunications Rooms and any other rooms only if they house servers storing sensitive information.

Note that this Guide G1-031 considers only physical safeguards. Information technology safeguards (such as passwords or encryption) may replace or augment some of these physical safeguards.

Accordingly, no separate server room should be required in situations where the building contains an Equipment Room of adequate size. If the Equipment Room is too small and a server room must be constructed, it will be shared by the departments occupying the space.

Scenarios

Few buildings now contain a standards-compliant infrastructure of telecommunications spaces (e.g. rooms) and pathways (e.g. conduit or cable tray), as specified in Standard TIA-569-B. In Crown-owned buildings as well as in buildings where the Crown has leased all the office space, base-building deficiencies will usually not be corrected until a major re-fit, such as at half-life. In some cases where the Crown has a long-term interest in a substantial portion of the building, it may also be practical to provide this holistic standards-compliant infrastructure during re-fit.

Some reasonable compromises with the Standard TIA-569-B are likely justified in shorter term leases. Accordingly, under this circumstance, the approach to the telecommunications system implementation will vary to suit the particular occupancy where meeting actual current requirements is more important than future-proofing. In general, the degree of compromise will be proportional to the size of the space leased and the occupancy length.

Some examples of possible scenarios and solutions are provided below for clarification. Many other scenarios and solutions are possible. Design decisions must be made by experts in telecommunications infrastructure design.

Scenario 1 – Modernized Crown-owned building or new major lease, multi-department occupancy

This is an example of a shared telecommunications infrastructure (including separate 24/7 air conditioning in the Equipment Room and Telecommunications Rooms²) that serves the building as a whole (similar to other utilities) as illustrated in Figure 1: Telecommunications Spaces and Pathways in Crown-owned Building. The construction complies with the mandatory requirements of the TIA standards. Small deviations from the non-mandatory requirements may have been implemented by the knowledgeable telecommunications designer to reflect actual conditions and common sense.

Located on one of the lower levels, the Equipment Room is sized for the Servers which are centralized.

Holistic shared backbone conduits connect the Telecommunications Rooms to the Equipment Room and also connect Telecommunications Rooms located on the same floor, where required. Zone conduits or cable trays are used for the backbone pathways connecting the Equipment Room to the combined Entrance Room/Common Equipment Room. These are also used as horizontal pathways to serve each zone on each floor. Generic backbone cabling is also provided.

Scenario 2 – Four floor occupancy, long term lease, "clean" space

This example provides the same telecommunications infrastructure under Scenario 1 above, but is limited to the four floors of the building leased by PWGSC – see Figure 2: Telecommunications Spaces and Backbone Pathways in Leased Spaces. The Common Equipment Room, Entrance Room, and Common Telecommunications Rooms are located outside of the leased space.

Scenario 3 – Four floor occupancy, long term lease, previously occupied space

This example incorporates the existing infrastructure to the extent that it does not deviate unacceptably from the TIA-569-B requirements.

Each floor is 2,400 m² and is served by two Telecommunications Rooms, one on each side of a central core. One Telecommunications Room on each floor is 8 m² and is determined to be

² Under all scenarios, if the clients require this air-conditioning system to be connected to standby power, it will be done at their expense; however, it will not be necessary to follow the non-compliance procedures.

acceptable. The other Telecommunications Room on each floor is only 4 m² and is enlarged to 10 m². The backbone pathways are found to be acceptable.

The Equipment Room is much too small when tested against Standard TIA-569-B and it is not practical to enlarge it. It has also been functioning as a Common Equipment Room and houses a small amount of Bell Canada-owned equipment. The landlord refuses to enlarge the existing Entrance Room so that it can function as a Common Equipment Room and also house Bell's equipment.

As rearranging backbone pathways would be costly, the existing Equipment Room is kept as a room housing the LAN switches and other Crown-owned electronic equipment required for the internal departmental networks. Part of this room is caged off to provide a separate space for Bell's equipment but Bell will not be able to access the remainder of the room. Another larger shared Equipment Room is built elsewhere in the space to house LAN servers of the departments occupying the space.

Generic backbone cabling is also provided.

Scenario 4 – Small (500 m² or less) long-term lease, previously occupied space

In this example, the space is all on the same floor. There is a single room that fulfills all telecommunications functions, but it is too small and is shared with equipment used for the distribution of electrical power. There are no backbones or horizontal pathways.

An existing room is found that is suitable for use as a combined Telecommunications Room and Equipment Room. Backbone pathways are installed connecting this room to a Common Telecommunications Room located outside of the leased space (see Figure 2: Telecommunications Spaces and Backbone Pathways in Leased Spaces). Given the small size of the space, J-hooks are used to support horizontal cable distribution. (Conduit or cable tray could also be used, if warranted by the characteristics of the space.)

Scenario 5 – Short-term lease (6 – 24 months), previously occupied large space

The Telecommunications Rooms are sized to meet the actual requirements of the client and make use of existing conditions wherever possible (i.e. common sense and best value for Canadians). In some cases, existing electrical room(s) may be used. An Equipment Room is sized as required to house network equipment and any departmental servers.

Given the short-term length of the lease, the client decides that separate 24/7 air conditioning is not required in either the Equipment Room or the Telecommunications Rooms. They agree to accept only exhaust fans and door vents in these rooms. They will activate the building's main air conditioning system on those days when the temperature in these rooms becomes excessively high. They agree that this approach reflects common sense and best value for Canadians. J-hooks are used to support horizontal cable distribution.

A4.2 Special Fire Protection Standards for Client-funded Requirements/SPS

In addition to provincial or territorial code requirements, there are some standards and policies that must be followed when developing office space for Government of Canada occupants. The most common ones are listed below. You may find the specific requirements of each at the accompanying Web site locations.

1. [TB Fire Protection Standard](#)
2. [Fire Commissioner of Canada – FC 311 \(M\) – Standard for Record Storage](#)
3. [Operations Program Directives No. 922-1-IPG-044 – Door Release Hardware – Electromagnetic Locks](#)
4. [Mobile Shelving – Fire Protection Design Requirements](#)

It is imperative that these standards and policies are considered early in the concept design stage, and as part of the review and approvals process throughout the development of the project.

A5. Planning

Changes Since the Last Update

A5.1 Planning and Workplace 2.0 Design Principles

- Additional information on the overall Workplace 2.0 concept and general physical workplace planning principles.
- Division of “Design Principles” section into subheadings with additional planning details in each section.

A5.2 Deletion of “Integrated Workplace Solutions” section

A5.2 Sample Plans

- New PL1 and PL2 floor plans, planning notes and legends applying Workplace 2.0 standards with a planning ratio of 60% fixed, 30% flex and 10% free workers.
- New PL3 and PL4 floor plans, planning notes and legends applying Workplace 2.0 standards with a planning ratio of 75% fixed, 20% flex and 5% free workers.

A5.1 Planning and Workplace 2.0 Design Principles

Although the *Workplace 2.0 Fit-up Standards* focus on the physical workplace, it is useful to understand the overall concept of Workplace 2.0 when implementing projects. Not all elements of Workplace 2.0 are within the control of the project team, only those involving the physical workplace. But understanding the importance of an integrated process for successful workplace renewal is key.

Workplace 2.0 is a whole-of-government approach, emphasizing a fully integrated and renewed workplace that supports the way we work today and includes:

- Modern, flexible work environments;
- Technological infrastructure to support the “anywhere, anytime, and any device” concept;
- Streamlined and modern policies;
- Updated back office systems to support delivery of programs to Canadians;
- Tools that support collaboration; and
- Cost savings in line with fiscal restraint.

Within the physical workplace, there are some general Workplace 2.0 planning principles to be considered in the overall project process, which include:

- Flexible office designs that integrate technology and business processes;

- Mobility and the flexibility to work from a variety of work spaces through the use of wireless and other mobile technologies (e.g. telephony, videoconferencing, etc.);
- Space based on worker profiles and time spent at the workplace;
- Limited hard-walled spaces and increased open collaborative areas;
- Accessibility in new workplace designs and new buildings;
- Strategically located buildings (e.g. transit routes); and
- Amenities that meet employee needs such as daycare, fitness and religious observance facilities.

Note: Successful integration of all the physical workplace elements of Workplace 2.0 requires an enriched front end process involving all members of the project team, including but not limited to real property, information management and technology, building services, acquisitions and the client, to ensure that Workplace 2.0 goals for the project are set and achieved.

Design Principles

The *Workplace 2.0 Fit-up Standards* allows for a design approach that maximizes long-term flexibility in the planning of office spaces. The approach incorporates innovative and sustainable design principles, and meets or exceeds all code, life safety and accessibility requirements.

The following planning and design principles support social, economic and environmental sustainability, and are to be applied to the greatest extent possible:

Sustainability

- The fit-up of Government of Canada office space is guided by the principles of energy efficiency, minimal environmental impact, occupant health and comfort and functional performance.
- The Government of Canada encourages the use of sustainability design tools such as Leadership in Energy and Environmental Design (LEED) and Green Globes. For interior fit-ups in existing buildings, materials selection and designing for good access to daylight are key factors in a sustainable design approach. PWGSC has reviewed the *Workplace 2.0 Fit-up Standards* to ensure that they do not inhibit achieving the criteria for LEED Commercial Interiors (CI) certification. Further information on LEED is available from the Canada Green Building Council. Information on Green Globes criteria is available from the Green Globes Web site.

Workstations

- Open workstations are assigned to the majority of the workers.
- The size of the workstations is based on the amount of time workers spend in the office.

- Smaller individual workstations offer the opportunity to introduce collaborative, group and other open support areas to increase interaction and facilitate the exchange of ideas.
- The number, orientation and height of screens (maximum 1.37 m (54")), varies to suit the functional requirements of occupants. Screens may not be required at all depending on the functions of the workers and the amount of time spent in the office.

Note: Workstations should be removed slightly from the windows where possible for better air circulation and to further increase the transfer of daylight.

Hard Walled Offices and Support Spaces

- Hard walled offices and support spaces are located adjacent to the core in order to maximize natural light on the floor, and the spaces are provided with glazing (for reusable partition systems) or sidelights or clerestory glazing, where appropriate.
- The "fixed" or permanent elements of the fit-up are limited and universally appropriate for the use of any occupant, minimizing construction and the need for future demolition. Construction is implemented to enable ease of disassembly and reuse to the greatest extent possible.
- Reusable partition systems (moveable, demountable) can be used to provide enclosed office and support space to increase flexibility. Such systems are an option when they can meet client program requirements and provide the best environmental and economic value to the Crown.
- Enclosed spaces are provided with individual lighting controls and sensors to conserve energy.
- Functions requiring enhanced or secure speech privacy are located near the core where acoustic control is not adversely affected by perimeter conditions. (Reference: *Speech Security: A Best Practice Guide*)
- Support spaces such as shared equipment areas, meeting rooms and kitchenettes should be located to concentrate noisier activities away from the workstation area, and minimize disruption for occupants. Banks of centralized filing can also be used to separate and buffer these types of spaces from the surrounding workstations.
- Kitchenettes accommodate recycling facilities and also serve as resource areas and informal meeting or work spaces and should be located adjacent to a collaborative area to maximize flexibility.
- Locating meeting rooms in a central location also provides convenience for visitors. Meeting rooms are located adjacent to each other, wherever possible, to provide convenience for visitors and to allow greater flexibility in the current and future use of the space (e.g. smaller meeting rooms may be combined to create a larger meeting room). While retractable or folding partition walls are provided as part of standard fit-up to divide a large meeting room, they may also be funded by the client to subdivide other meeting rooms to provide for greater versatility in the use of the space.

Note: The project team technical experts should ensure due diligence with regards to product selection and advise the client accordingly of the pros and cons to consider.

- Finishes are chosen for their durability (low maintenance or life cycle cost), recyclability, low embodied energy (locally available if possible) and low toxicity. See A7 for further information on finishes.

Security

- Security requirements must be fully integrated into the planning and design of government accommodation.
- Security requirements identified by a Threat and Risk Assessment can usually be met using a combination of one or more design features including zoning of restricted access areas, entry barriers, security systems and equipment.
- Client departments are responsible for informing PWGSC of their security requirements for tenant fit-up. The necessary security specifications must be included in all plans, funding requirements, requests for proposals and tender documentation for fit-up projects. Client departments should refer to the [Government Security Policy](#) and the [Operational Security Standard on Physical Security](#) when planning security requirements.

The exact size, configuration and placement of spaces will vary to suit each building's particular characteristics. The sample floor plans in A5.3 generally demonstrate the principles as outlined.

The national average for general office accommodation is 14.0 m² per FTE. For all projects, consideration must be given to the potential impact of densification on the building and building services. All applicable codes and standards must be adhered to.

A5.2 Sample Plans

PL1 DIAGRAM

Planning Notes and Legend for PL1 Diagram

Large Floor Plan – Planning Ratio 60% Fixed, 30% Flex and 10% Free

General Information

Space Allocation Limits for 152 FTE (usable): 2,006.6 m² (21,599.3 ft²)

Sample plan total space (usable): 1,749.10 m² (18,827.2 ft²)

Sample plan total space (rentable): 1,894.77 m² (20,395.1 ft²)

Space Allocation Limits Utilization for 152 FTE (usable): 13.2 m²/FTE (142.1 ft²/FTE)

Sample plan space per FTE (usable): 11.5 m²/FTE (123.8 ft²/FTE)

Sample plan space per FTE (rentable): 12.5 m²/FTE (134.5 ft²/FTE)

Office and Workstation Space

Office and workstation area: 678.4 m² (7,302.2 ft²)

Total FTEs: 152 (146 workstations, 6 closed office)

- Leadership: 6
- Fixed: 87
- Flex: 45
- Free: 14

Support Space

Total support area: 463.8 m² (4,992.3 ft²)

- Total open support areas: 122.2 m² (1,315.6 ft²)
- Total enclosed support areas: 341.6 m² (3,676.9 ft²)
- Open support/enclosed support ratio: 26%/74%

List of Support Spaces:

- 2 small meeting rooms
- 2 medium meeting rooms
- 1 large meeting room
- 4 quiet rooms
- 2 shared equipment areas (could be allocated 3)
- 1 kitchenette
- 3 Undesignated Support Spaces (USS)
- 7 Open Collaboration Areas (6%)

Circulation and Design Contingency

Circulation space: 647.1 m² (6,965.3 ft²)

Circulation percentage: 37% (includes building loss factor)

Screen Configuration

The number of screens used to define each workstation will vary depending on proximity to major circulation paths vs. secondary circulation or windows areas. The illustrated configuration is considered adequate for a typical office environment.

See A3.4 for planning ratios and other requirements.

PL1 Diagram

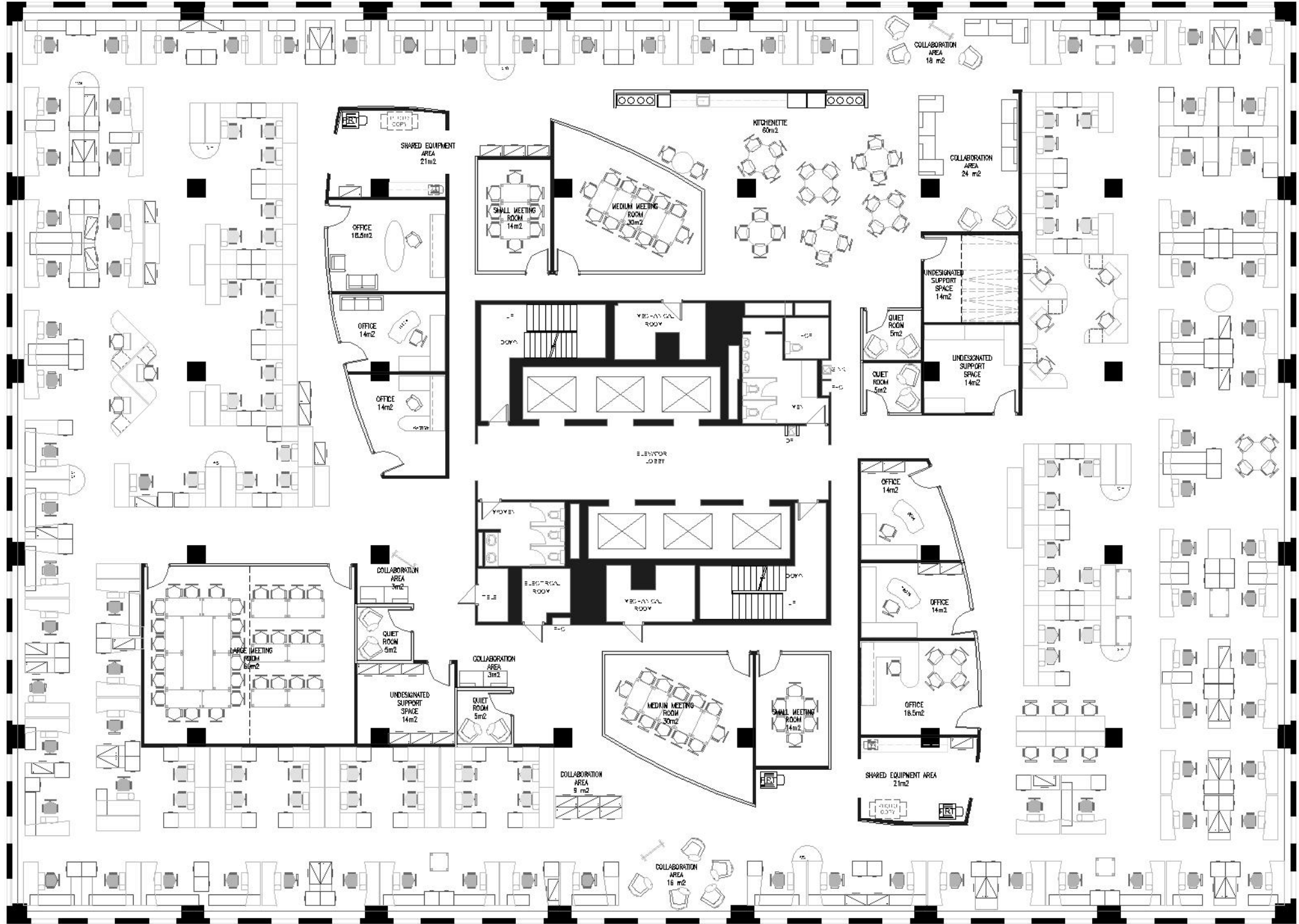

PL2 DIAGRAM

Planning Notes and Legend for PL2 Diagram

Small Floor Plan – Planning Ratio 60% Fixed, 30% Flex and 10% Free

General Information

Space Allocation Limits for 76 FTE (usable): 1,037.07 m² (11,162.9 ft²)

Sample plan total space (usable): 1,029.53 m² (11,081.8 ft²)

Sample plan total space (rentable): 1,165.07 m² (12,540.71 ft²)

Space Allocation Limits Utilization for 76 FTE (usable): 13.7 m²/FTE (147.5 ft²/FTE)

Sample plan space per FTE (usable): 13.55 m²/FTE (145.9 ft²/FTE)

Sample plan space per FTE (rentable): 15.3 m²/FTE (164.7 ft²/FTE)

Office and Workstation Space

Office and workstation area: 343.2 m² (3,694.4 ft²)

Total FTEs: 76 (74 workstations, 2 closed office)

- Leadership: 2
- Fixed: 45
- Flex: 22
- Free: 7

Support Space

Total support area: 313.4 m² (3,373.1 ft²)

- Total open support areas: 141.5 m² (1,523.2 ft²)
- Total enclosed support areas: 171.9 m² (1,849.9 ft²)
- Open support/closed support ratio: 45%/55%

List of Support Spaces:

- 2 small meeting rooms
- 2 medium meeting rooms
- 2 quiet rooms
- 1 shared equipment area (could be allocated 2)
- 1 kitchenette
- 2 Undesignated Support Spaces (USS)
- 2 Open Collaboration Areas (7%)

Circulation and Design Contingency

Circulation space: 370.6 m² (3,989.1 ft²)

Circulation percentage: 36% (includes building loss factor)

Screen Configuration

The number of screens used to define each workstation will vary depending on proximity to major circulation paths vs. secondary circulation or windows areas. The illustrated configuration uses low screens for greater light penetration and a cluster layout for greater collaboration.

See A3.4 for planning ratios and other requirements.

PL2 Diagram

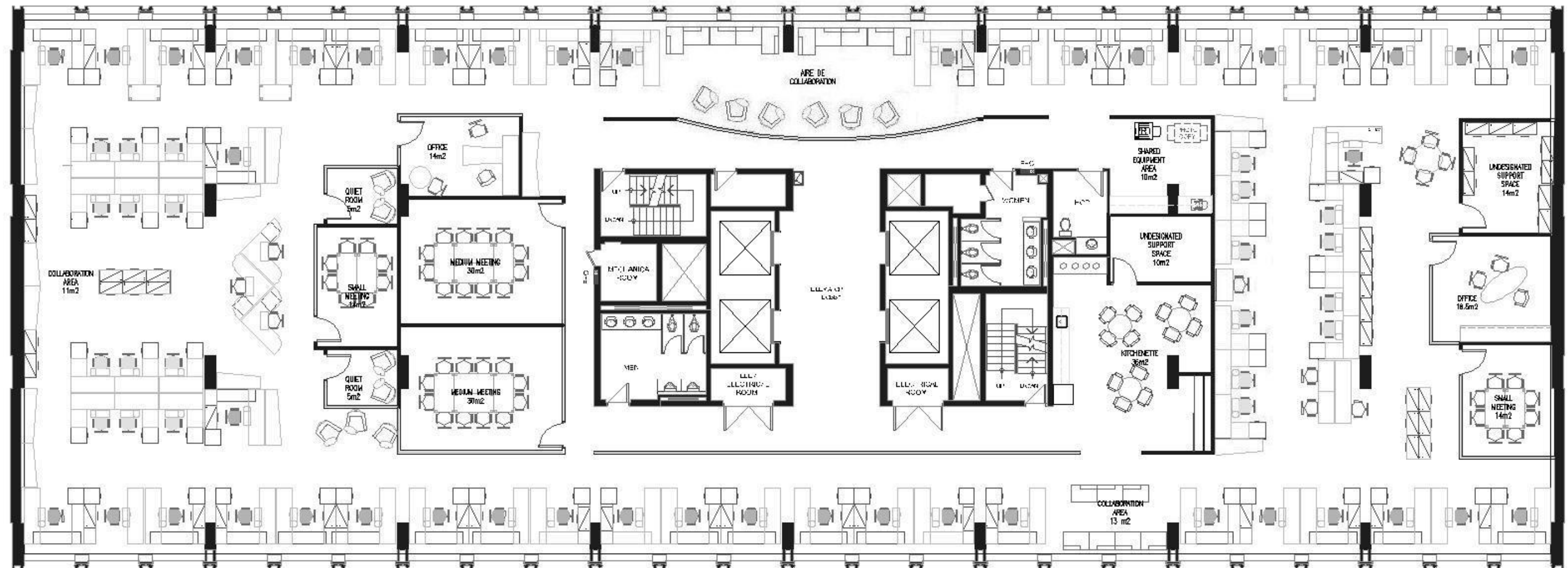

PL3 DIAGRAM

Planning Notes and Legend for PL3 Diagram

Large Floor Plan – Planning Ratio 75% Fixed, 20% Flex and 5% Free

General Information

Space Allocation Limits for 140 FTE (usable): 1,853.6 m² (19,951.9 ft²)

Sample plan total space (usable): 1,749.10 m² (18,827.2 ft²)

Sample plan total space (rentable): 1,894.77 m² (20,395.1 ft²)

Space Allocation Limits Utilization for 140 FTE (usable): 13.2 m²/FTE (142.5 ft²/FTE)

Sample plan space per FTE (usable): 12.5 m² (134.5 ft²/FTE)

Sample plan space per FTE (rentable): 13.5 m²/FTE (145.31 ft²/FTE)

Office and Workstation Space

Office and workstation area: 651.9 m² (7,016.7 ft²)

Total FTEs: 140 (134 workstations, 6 closed office)

- Leadership: 6
- Fixed: 97
- Flex: 27
- Free: 10

Support Space

Total support area: 477.8 m² (5,143 ft²)

- Total open support areas: 135.9 m² (1,462.8 ft²)
- Total enclosed support areas: 341.9 m² (3,680.2 ft²)
- Open support/closed support ratio: 28%/72%

List of Support Spaces:

- 2 small meeting rooms
- 2 medium meeting rooms
- 1 large meeting room
- 4 quiet rooms
- 2 shared equipment area
- 1 kitchenette
- 3 Undesignated Support Spaces (USS)
- 6 Open Collaboration Areas totaling (4%)

Circulation and Design Contingency

Circulation space: 664.7 m² (7,154.7 ft²)

Circulation percentage: 38% (includes building loss factor)

Screen Configuration

The number of screens used to define each workstation will vary depending on proximity to major circulation paths vs. secondary circulation or windows areas. The illustrated configuration is considered adequate for a typical office environment.

See A3.4 for planning ratios and other requirements.

PL3 Diagram

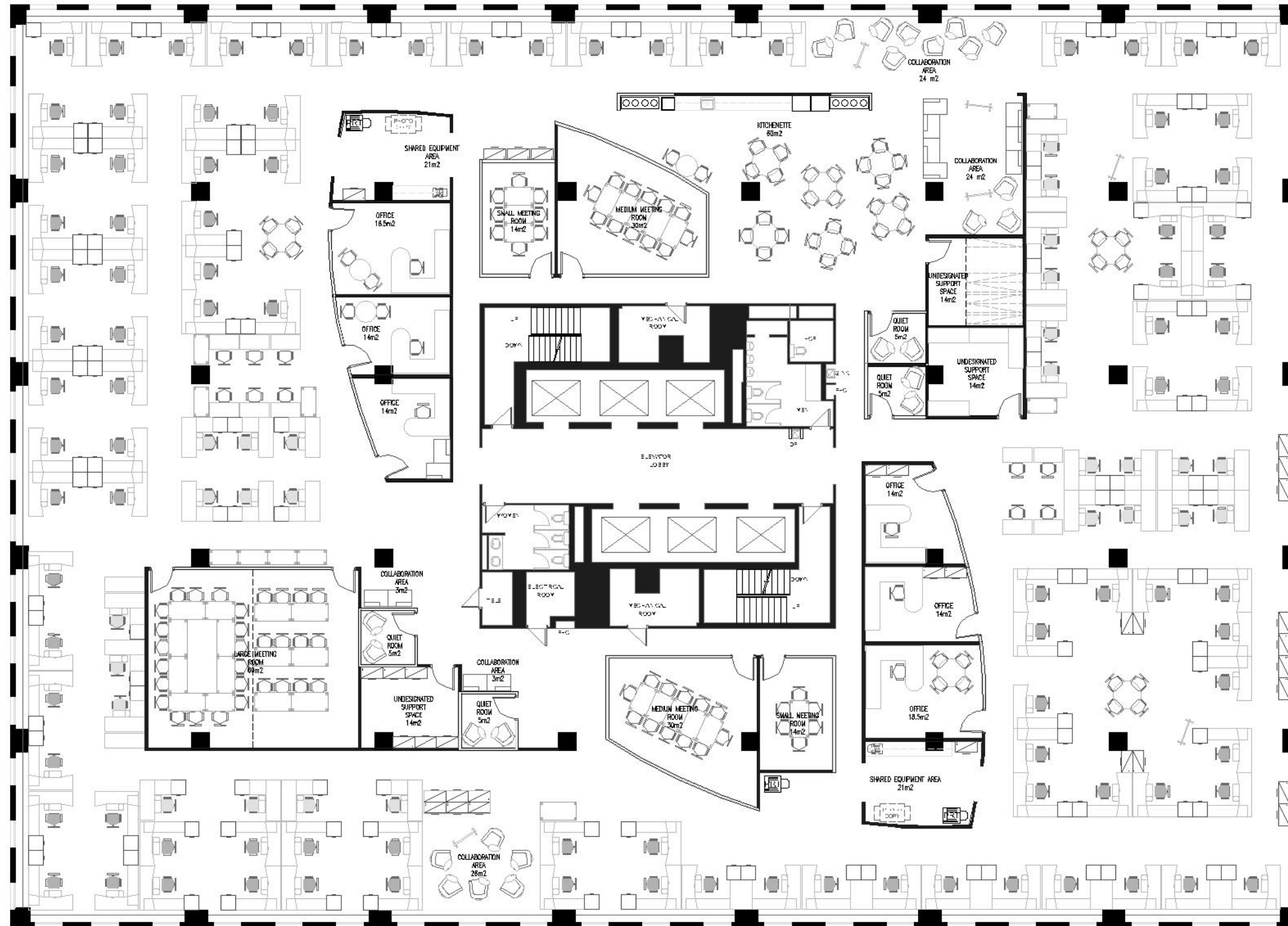

PL4 DIAGRAM

Planning Notes and Legend for PL4 Diagram

Small Floor Plan – Planning Ratio 75% Fixed, 20% Flex and 5% Free

General Information

Space Allocation Limits for 76 FTE (usable): 1,037.07 m² (11,162.9 ft²)

Sample plan total space (usable): 1,029.53 m² (11,081.8 ft²)

Sample plan total space (rentable): 1,165.07 m² (12,540.71 ft²)

Space Allocation Limits Utilization for 76 FTE (usable): 13.7 m²/FTE (147.5 ft²/FTE)

Sample plan space per FTE (usable): 13.55 m² (145.9 ft²)

Sample plan space per FTE (rentable): 15.32 m²/FTE (164.9 ft²/FTE)

Office and Workstation Space

Office and workstation area: 387.9 m² (4,175.3 ft²)

Total FTEs: 76 (74 workstations, 2 closed office)

- Leadership: 2
- Fixed: 55
- Flex: 14
- Free: 5

Support Space

Total support area: 274.9 m² (2,958.5 ft²)

- Total open support areas: 88.6 m² (953.7 ft²)
- Total enclosed support areas: 186.25 m² (2,004.78 ft²)
- Open support/closed support ratio: 32%/68%

List of Support Spaces:

- 2 small meeting rooms
- 2 medium meeting rooms
- 2 quiet rooms
- 1 shared equipment area (could be allocated 2)
- 1 kitchenette
- 2 Undesignated Support Spaces (USS)
- 2 Open Collaboration Areas (10%)

Circulation and Design Contingency

Circulation space: 360.3 m² (3,878.2 ft²)

Circulation percentage: 35% (includes building lose factor)

Screen Configuration

The number of screens used to define each workstation will vary depending on proximity to major circulation paths vs. secondary circulation or windows areas. The illustrated configuration includes open, collaborative spaces and a cluster layout.

See A3.4 for planning ratios and other requirements.

PL4 Diagram

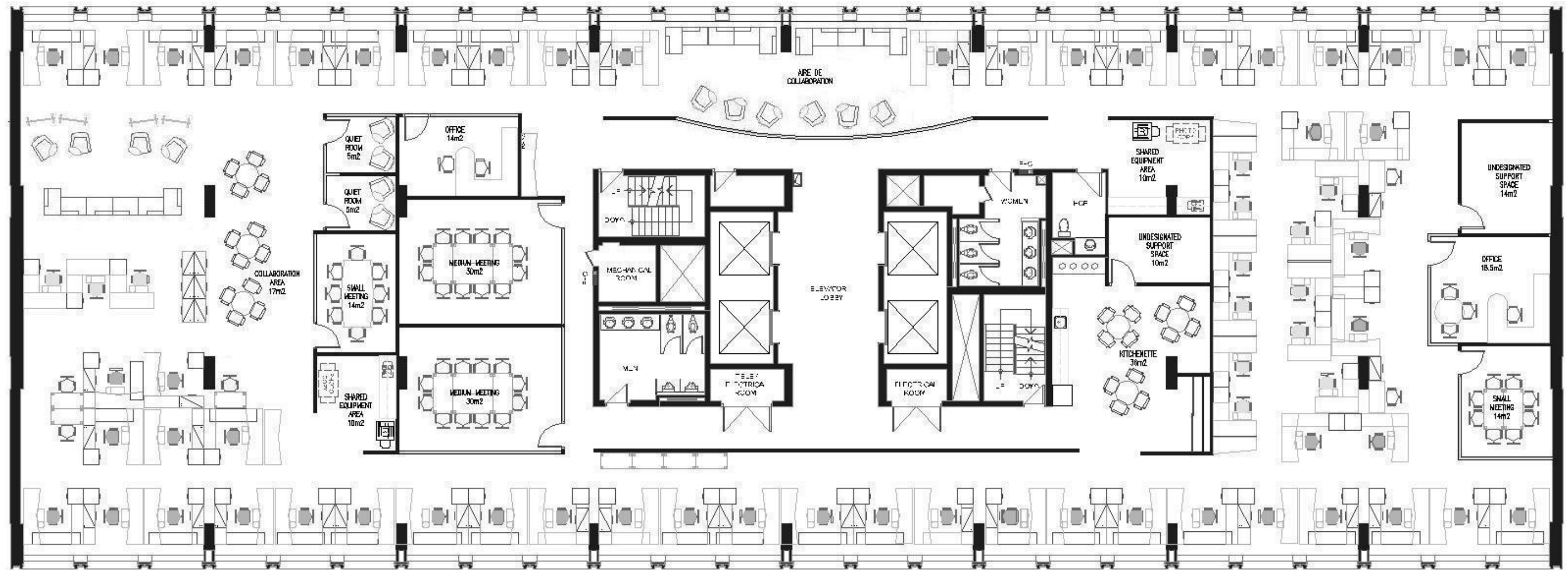

A6. Sample Detail Drawings

Changes Since the Last Update

- A6.1 Workstations, Collaborative and Enclosed Spaces
 - Modification to examples of workstation and enclosed office layouts.
 - Clarification and description of collaborative spaces and new examples of collaborative space layouts.
- A6.2 Support Spaces
 - Additional data/electrical outlets in medium and large meeting rooms, mandatory retractable wall in large meeting room and revision to examples of meeting room layouts.
 - Addition of barrier free wording for quiet rooms and optional layout examples provided.
 - Optional freestanding manufactured solution for upper and lower cabinets in kitchenettes and shared equipment areas.
 - Addition of ceramic tile backsplash in kitchenettes and update to drawings.
- A6.3 Doors and Glazing
 - Addition of glazed doors (with frames) as part of a demountable/moveable wall system.

A6.1 Workstations, Collaborative and Enclosed Spaces

Open Workstations

Summary

Workstations vary in size depending on function (see A3.4) and accommodate average requirements for work surfaces, storage and filing. Filing cabinets may be centralized as an alternative layout. The use of freestanding, height adjustable and mobile furniture components is encouraged for increased flexibility.

Note: Furniture layouts are provided for example and may vary.

The height of filing cabinets may vary to suit workstation locations (e.g., window locations – maximum two drawers high to allow transfer of natural light).

Standard Finishes

Floor – base building standard carpet (carpet tile or rolled goods)

Standard Electrical Requirements

- 3 standard electrical duplex receptacles (1 circuit per 2 workstations)
- 1 image/voice/data/outlet
(**Note:** client to provide actual connectors and jacks, typically RJ45 with multiple jacks)
- Base building lighting

Free Worker

Examples of Workstation Layouts (cluster)

1.5 m² (16 ft²)

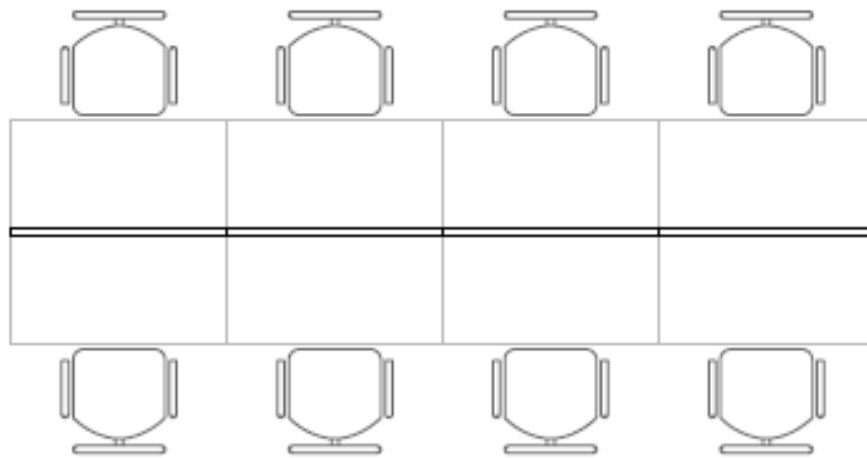

Cluster Layout (1.5 m²)

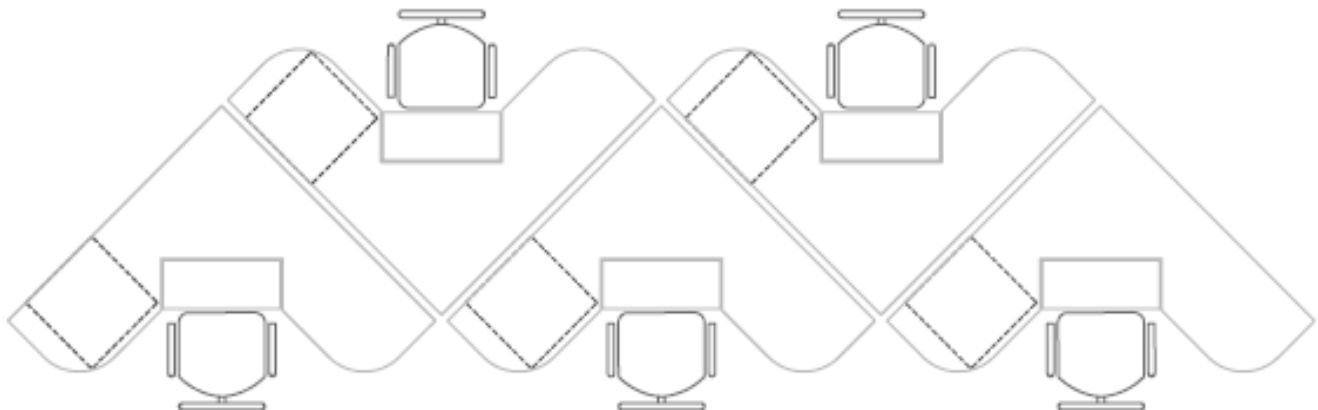

Alternate Cluster Layout (1.5 m²)

Flexible Worker

Example of Workstation Layouts (individual)

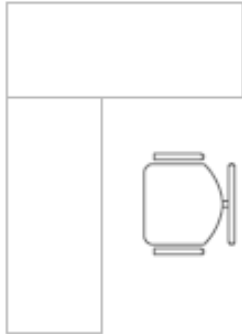
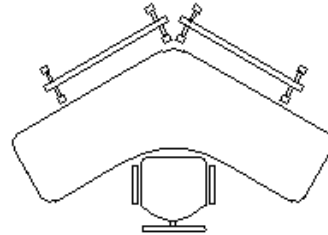
3.0 m² (32 ft²)Layout (3.0 m²)Alternate Layout (3.0 m²)

Example of Workstation Layouts (cluster)

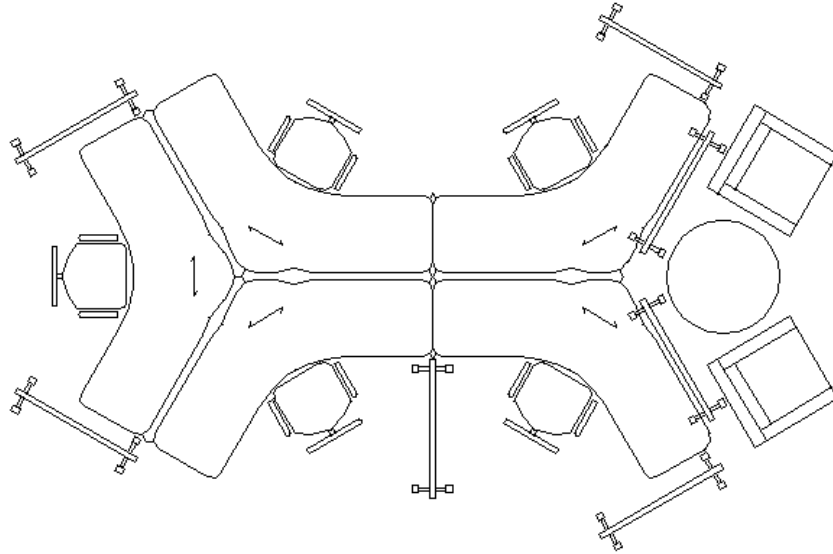
3.0 m² (32 ft²)Cluster Layout (3.0 m²)

Fixed Worker

Examples of Workstation Layouts (individual)

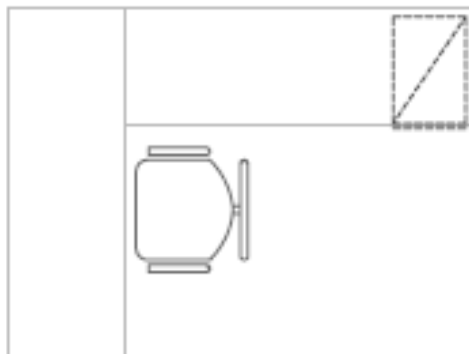
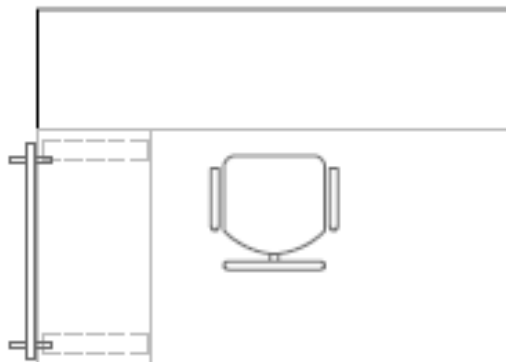
4.5 m² (48 ft²)Layout (4.5 m²)Alternate Layout (4.5 m²)

Fixed Worker

Examples of Workstation Layouts (cluster)

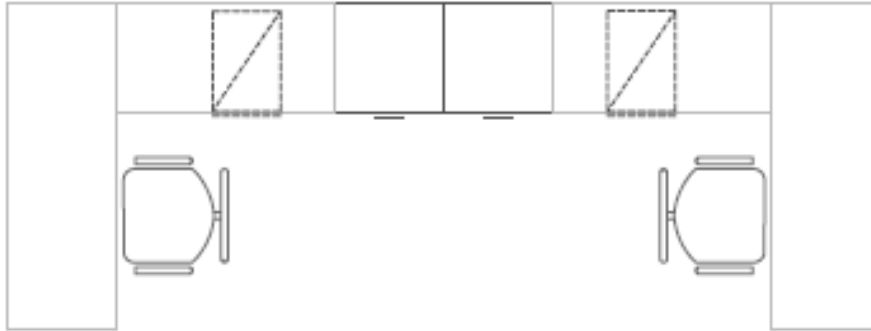
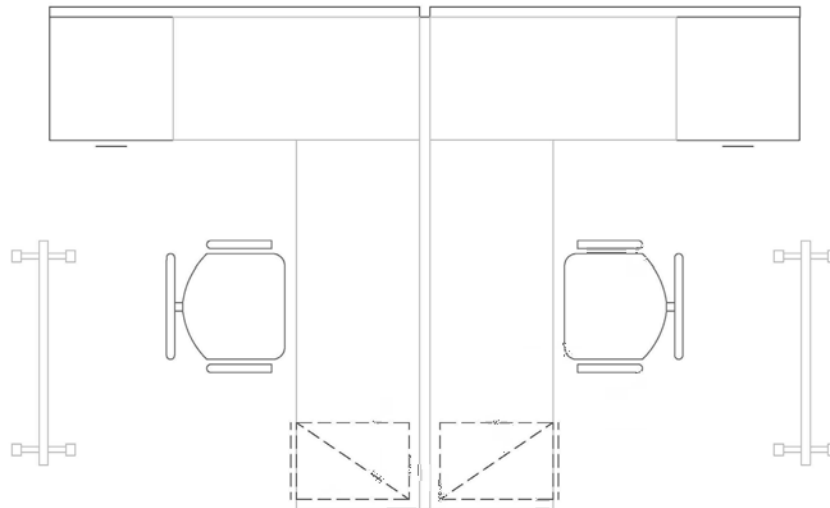
4.5 m² (48 ft²)Cluster Layout – 2 (4.5 m²)Alternate Cluster Layout – 2 (4.5 m²)

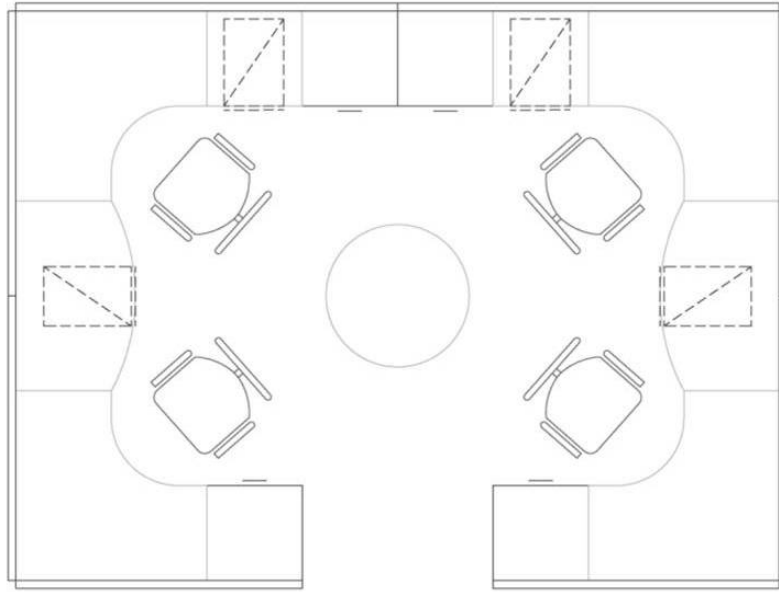

Cluster Layout – 4 (4.5 m²)

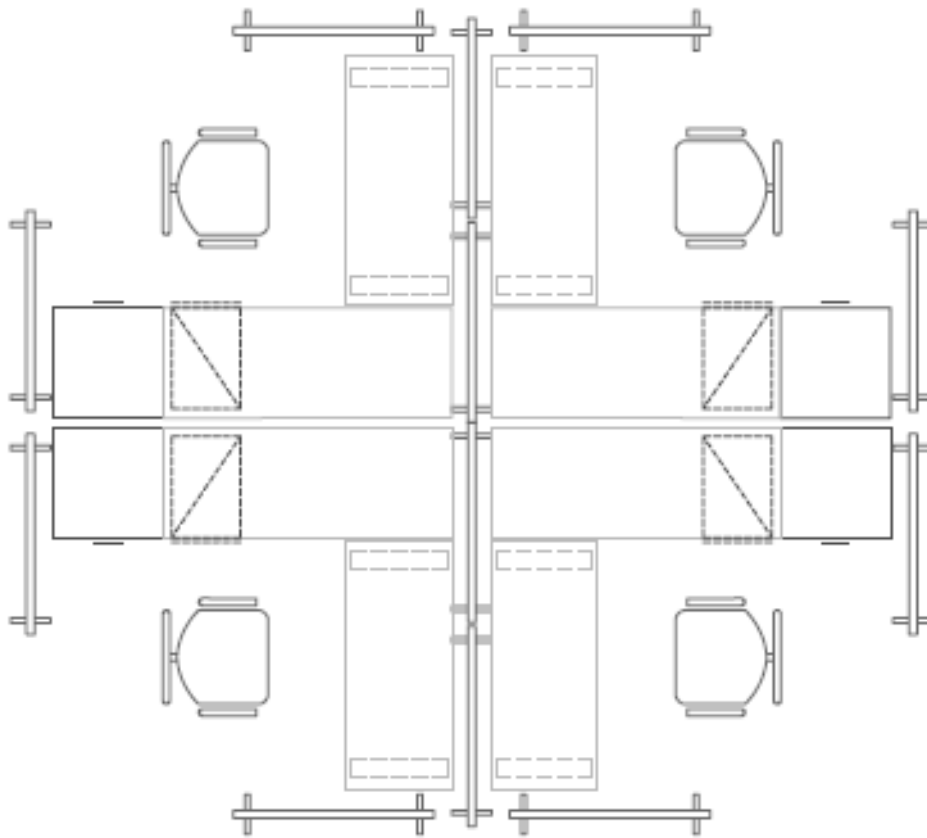

Alternate Cluster Layout – 4 (4.5 m²)

Collaborative Spaces

Summary

Collaborative spaces vary in size and quantity depending on the floor layout, function and space available (see A3.4). Collaborative spaces create environments to help people connect and communicate freely, and encourage teamwork and idea sharing.

A variety of furniture can be provided (client funded) to suit the function of the collaborative space such as tablet chairs, soft seating, mobile tables and other flexible furniture that can be arranged in various configurations. White boards and other display options should also be included.

Note: Furniture layouts are provided for example and may vary.

Standard Finishes

Floor – base building standard carpet (carpet tile or rolled goods)

Standard Electrical Requirements

- 3 standard electrical duplex receptacles (floor or wall mounted on 2 circuits) per 15 m² of space
- 2 image/voice/data/outlet per 15 m² of space
(**Note:** client to provide actual connectors and jacks, typically RJ45 with multiple jacks.)
- Base building lighting

Examples of Collaborative Space Layouts

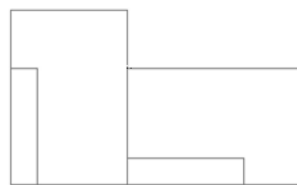
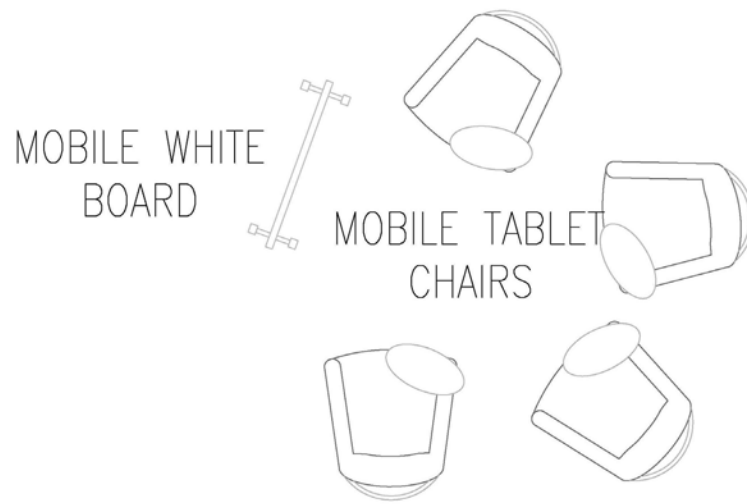

Enclosed Offices

Summary

Offices accommodate average requirements for work surfaces, shelving, storage and filing. Furniture can be freestanding or hung from reusable partition systems.

Note: Furniture layouts are provided for example and may vary.

Finishes

- Floor – base building standard carpet (carpet tile or rolled goods)
- Walls – paint or unfinished
(**Note:** partitions may be traditional construction or reusable partition systems, see A3.3 Fit-up Components and Funding Accountabilities.)

Standard Electrical Requirements

- 3 standard electrical duplex receptacles (2 circuits)
- 2 image/voice/data outlets
(**Note:** client to provide actual connectors and jacks, typically RJ45 with multiple jacks.)
- Base building lighting (may be relocated) with 1 separate switch/light control

Standard Mechanical Requirements

Interior zone:

- Individual thermostat control c/w dedicated terminal unit (VAV box, fan coil unit)
- Supply and return air diffuser(s)/grille(s)
- Transfer return air fan c/w on/off switch for full height partitions

Perimeter zone (where required):

- Individual thermostat control for terminal units and perimeter system (convactor(s), fan coil unit(s))
- Transfer return air fan c/w on/off switch for full height partitions
- Supply and return air diffuser(s)/grille(s)
- Noise abatement as required

Leadership Worker

Examples of Enclosed Office Layouts

10 m² (100 ft²)

Note: Maximum allowance for EX-1 positions with 10 or more funded reports, senior departmental representatives at regional offices or remote locations, lawyers and ICMS employees. See A3.4 for further details.

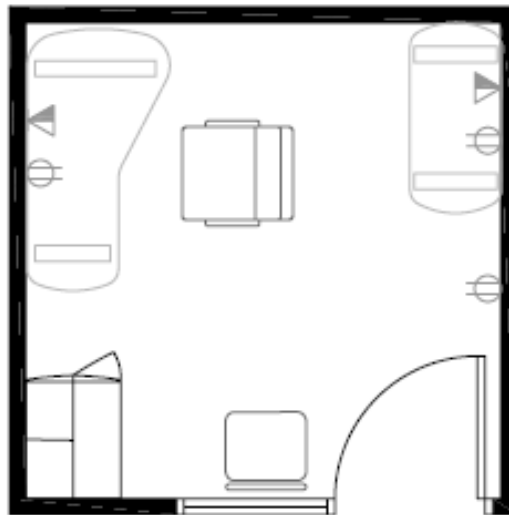
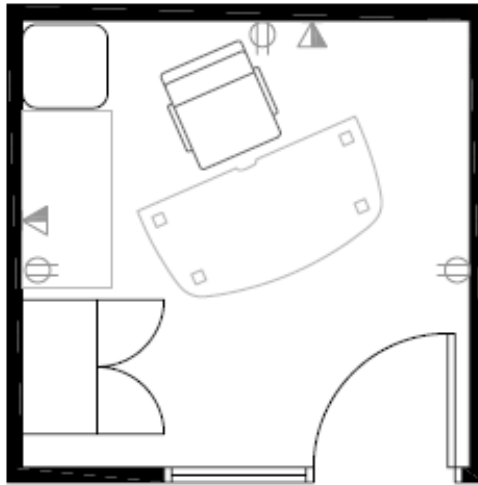

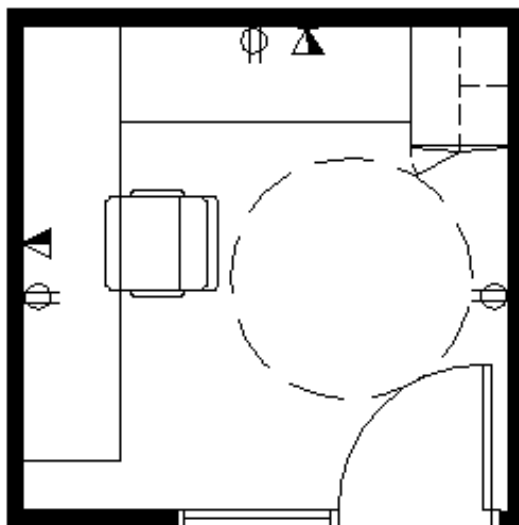

Note: This example provides for fully accessible office.

Leadership Worker

Examples of Enclosed Office Layouts

14 m² (150 ft²)

Note: Maximum allowance for EX-3, EX-2 and EX-1 positions and equivalents, no more than 3 levels below the DM or Associate DM. See A3.4 for further details.

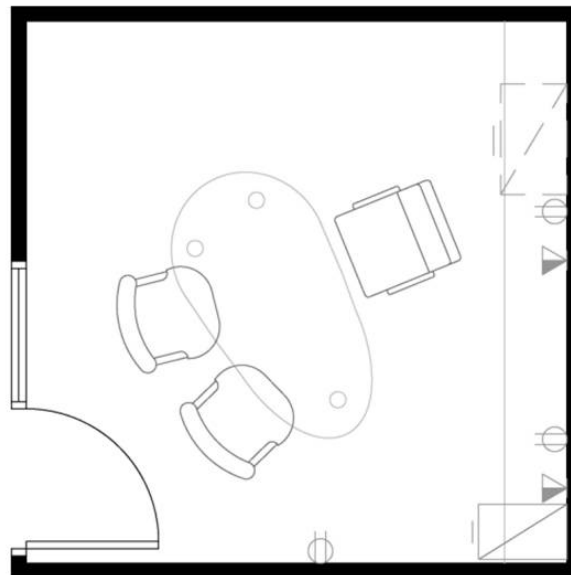
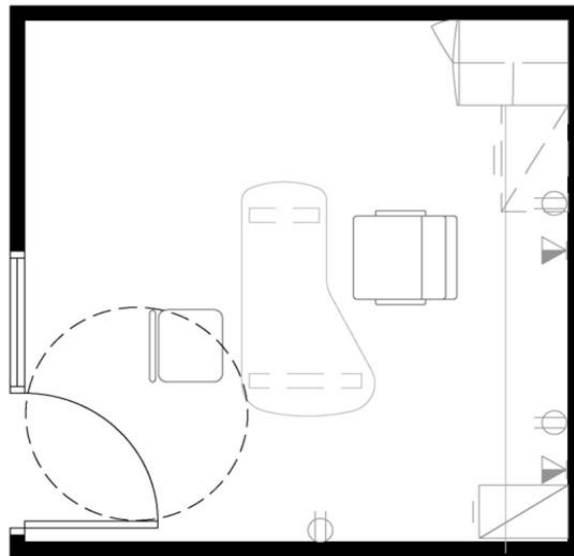

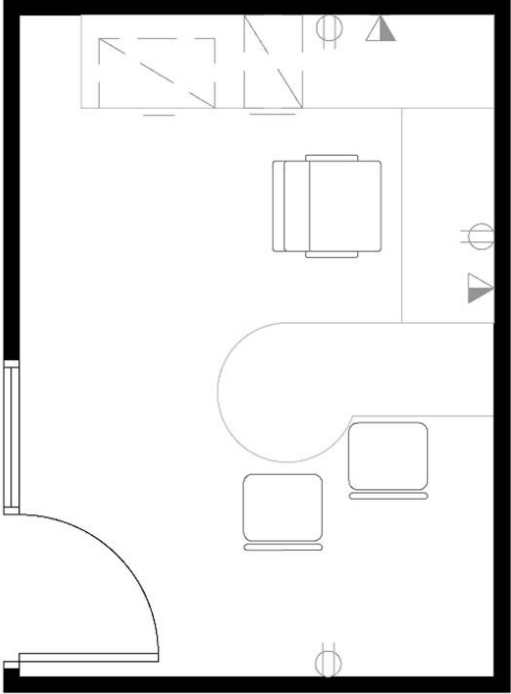

Leadership Worker

Examples of Enclosed Office

18.5 m² (200 ft²)

Note: Maximum allowance for EX-5 and EX-4 positions and equivalents (e.g., ADMs, members of boards, commissions and councils).

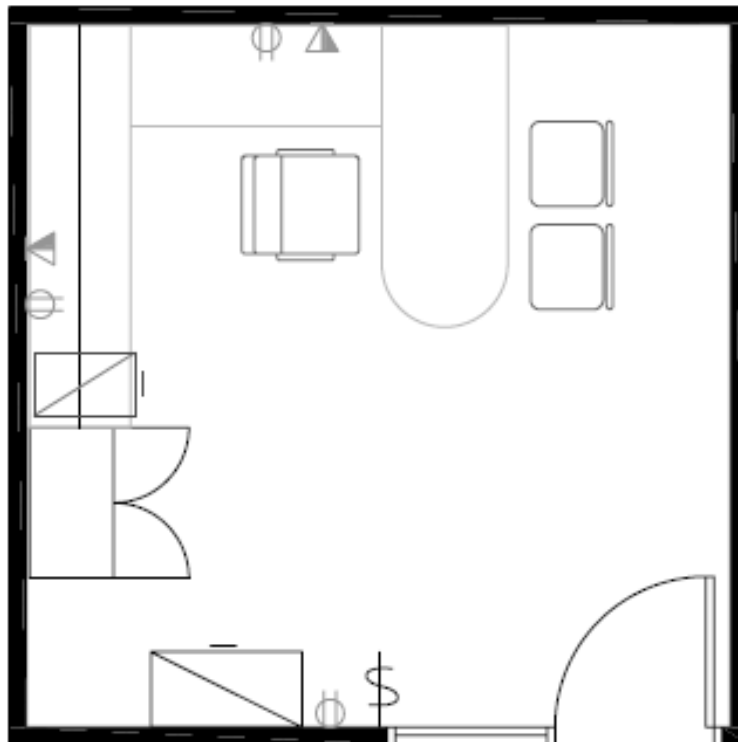
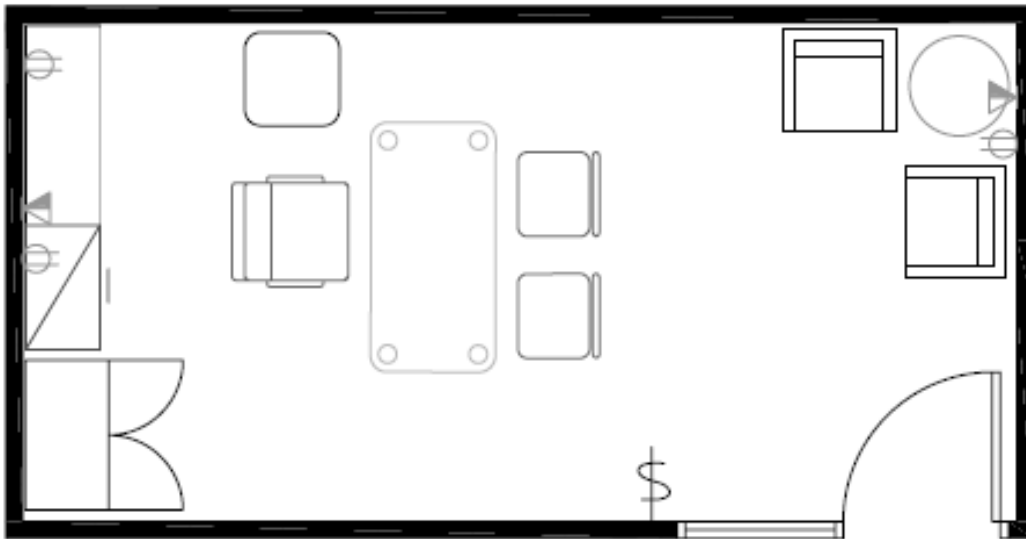

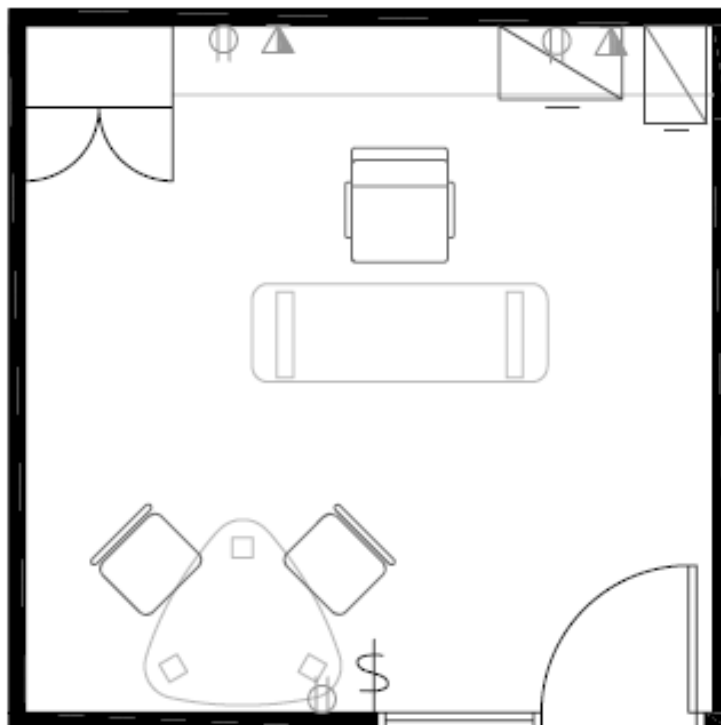

A6.2 Support Spaces

Small Meeting Room

14 m² (150 ft²)

Summary

Small meeting rooms can accommodate a meeting table, chairs for 6 people and an audiovisual board. The room size should allow for comfortable circulation space and room for a presenter to function comfortably at one end. The meeting room table can also be comprised of smaller modular tables put together to maximize functionality.

Other layouts incorporating soft seating and casual tables for less formal meetings are also possible.

Standard Finishes

- Floor – base building standard carpet (carpet tile or rolled goods)
- Walls – paint or unfinished to suit substrate
(**Note:** partitions may be traditional construction or reusable system partitions (e.g. movable, demountable; see A3.3).)

Standard Electrical Requirements

- 3 standard electrical duplex receptacles (2 circuits)
- 2 image/voice/data outlets
(**Note:** client to provide actual connectors and jacks, typically RJ45 with multiple jacks.)
- Base building lighting (may be relocated) with separate switch/light control and motion sensor
- Direct/indirect suspended luminaire(s) to suit meeting (table) function on a separate switch/light control and motion sensor
- Dimmable perimeter/accent lighting to support presentation function on a separate switch/light control and motion sensor

Standard Mechanical Requirements

- Dedicated thermostat control c/w dedicated terminal unit
- Supply and return air diffuser(s)/grille(s)
- Return air transfer fan c/w on/off switch for full height partitions increased ventilation

Example of Small Meeting Room Layouts

14 m² (150 ft²)

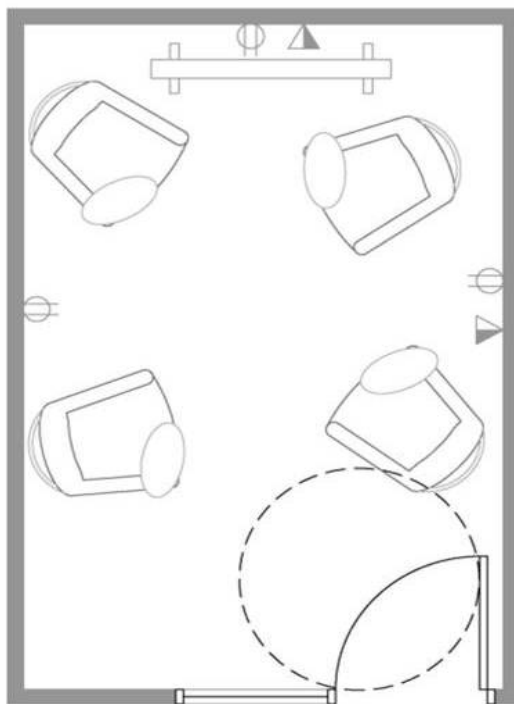
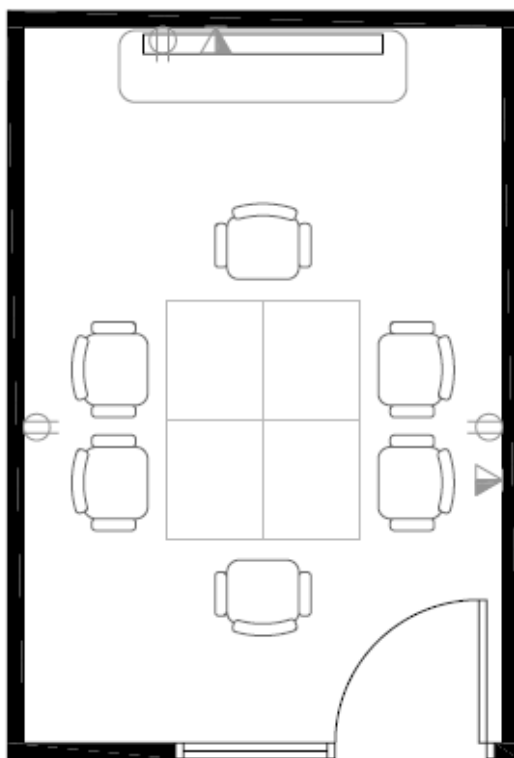

Small Meeting Room (reflected ceiling)

14 m² (150 ft²)

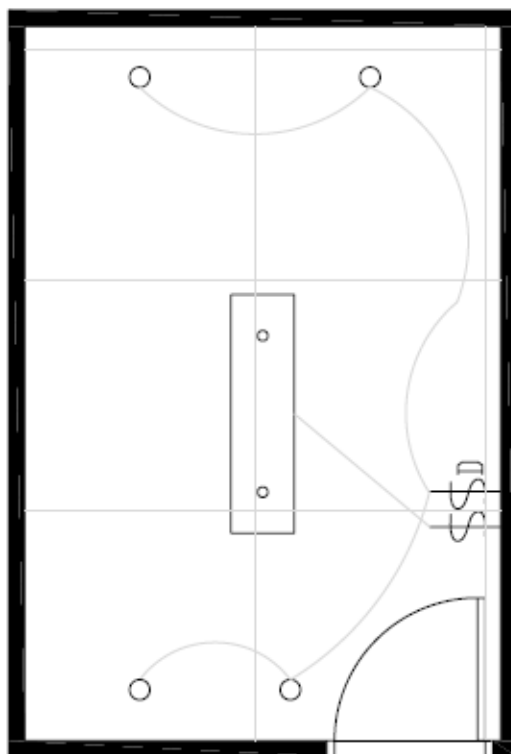

Medium Meeting Room

30 m² (325 ft²)

Summary

Medium meeting rooms accommodate a meeting table, chairs for 12 people and an audiovisual board. The room size should allow for comfortable circulation space and room for a presenter to function comfortably at one end. The meeting room table should be mobile and comprised of smaller modular tables put together to maximize functionality.

Standard Finishes

- Floor – base building standard carpet (carpet tile or rolled goods)
- Walls – paint or unfinished to suit substrate

Standard Electrical Requirements

- 4 standard electrical duplex receptacles (2 circuits); 1 only floor mounted
- 3 image/voice/data outlets; 1 only floor mounted
(**Note:** client to provide actual connectors and jacks, typically RJ45 with multiple jacks.)
- Base building lighting with motion sensor
- Direct/indirect suspended luminaire(s) to suit meeting (table) function on a separate switch/light control and motion sensor
- Dimmable perimeter/accent lighting to support presentation function on a separate switch/light control and motion sensor

Standard Mechanical Requirements

- Dedicated thermostat control c/w dedicated terminal unit
- Supply and return air diffuser(s)/grille(s)
- Return air transfer fan c/w on/off switch for full height partitions
- Extra cooling unit, if required
- Extra ventilation to meet ventilation demand c/w controls and CO₂ monitoring, if applicable
- Noise control to maintain required noise rating

Examples of Medium Meeting Room Layouts

30 m² (325 ft²)

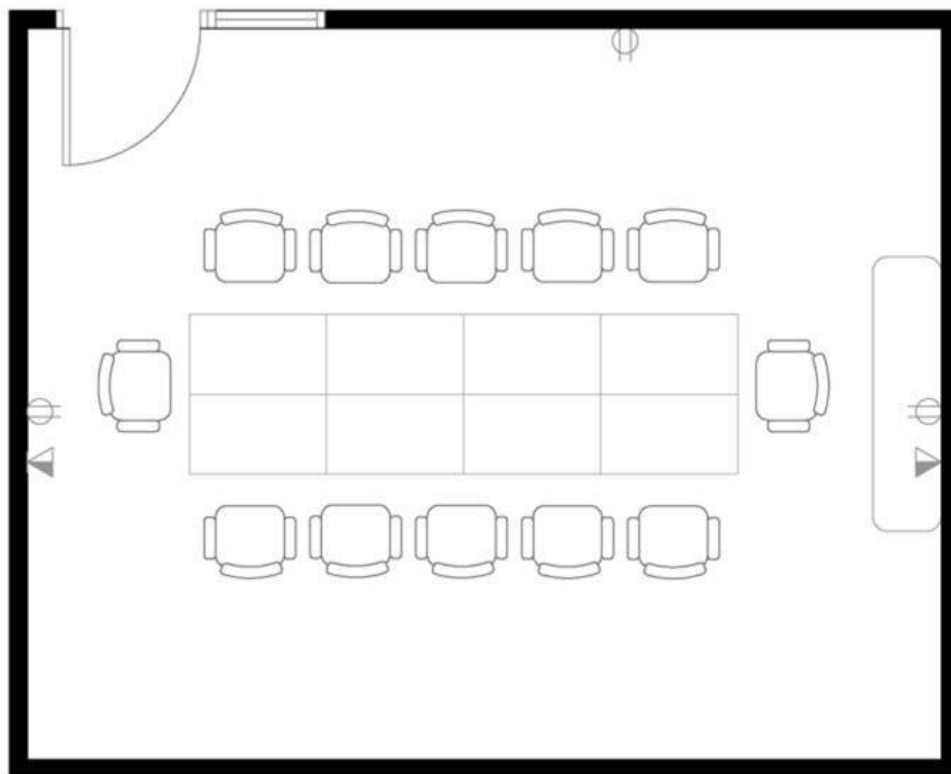
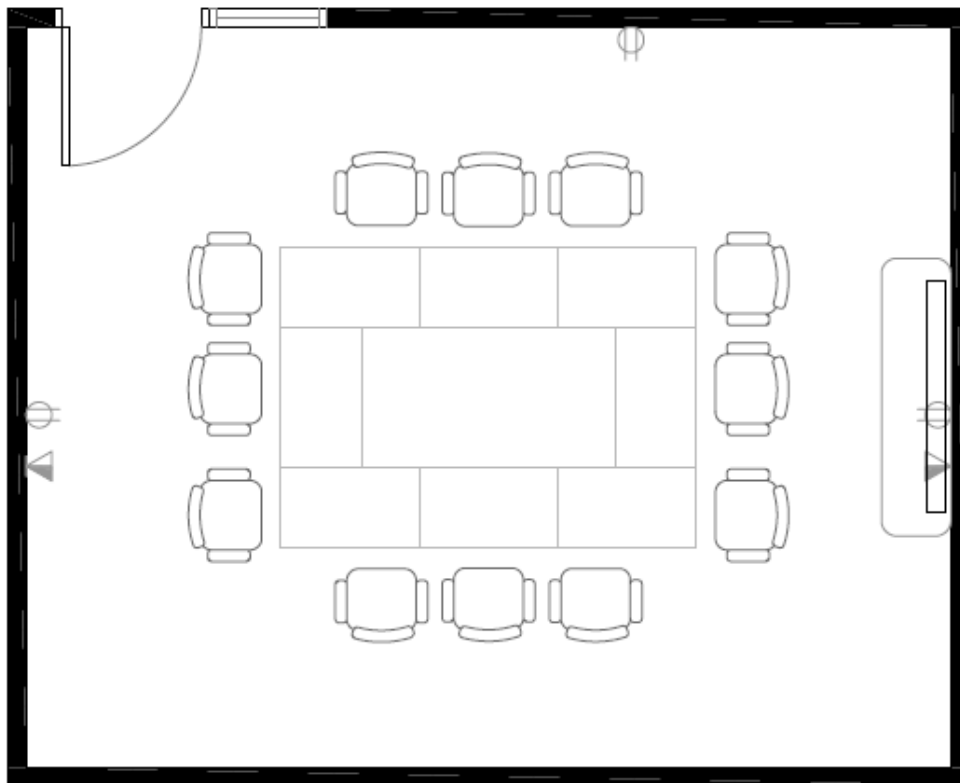

Medium Meeting Room (reflected ceiling)

30 m² (325 ft²)

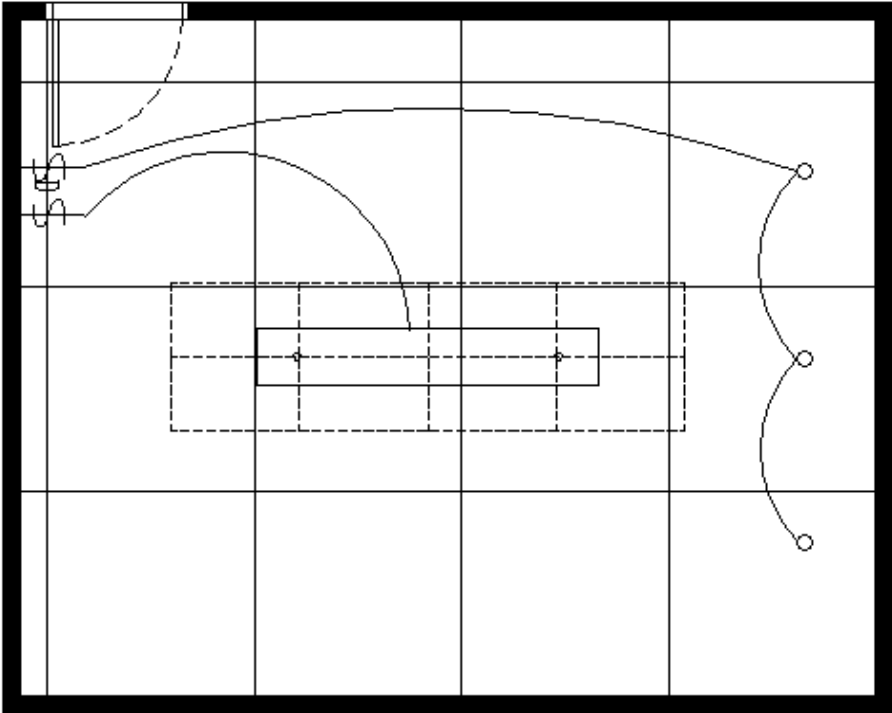

Large Meeting Room (Dividable)

60 m² (645 ft²)

Summary

The large meeting room consists of 2 medium sized meeting rooms divided by a retractable wall to maximize flexibility. When the wall is retracted, the room accommodates a meeting table, chairs for 20 people and presenter's equipment and materials. The room size should allow for comfortable circulation space and room for a presenter to function comfortably at one end. The meeting room table should be mobile and comprised of smaller modular tables put together to maximize functionality.

Standard Finishes

- Floor – base building standard carpet (carpet tile or rolled goods)
- Walls – paint or unfinished to suit substrate

Standard Electrical Requirements

- 4 standard electrical duplex receptacles (two circuits); 2 floor mounted (one per room)
- 4 image/voice/data outlets; 2 floor mounted (one per room)
(**Note:** client to provide actual connectors and jacks, typically RJ45 with multiple jacks.)
- Base building lighting with motion sensor
- Direct/indirect suspended luminaire(s) to suit meeting (table) function on a separate switch/light control with motion sensor
- Dimmable perimeter/accent lighting to support presentation with motion sensor

Standard Mechanical Requirements

- Dedicated thermostat control c/w dedicated terminal unit
- Supply and return air diffuser(s)/grille(s)
- Return air transfer fan c/w on/off switch for full height partitions
- Extra cooling unit, if required
- Extra ventilation to meet ventilation demand c/w controls and CO₂ monitoring, if applicable
- Noise control to maintain required noise rating

Examples of Large Meeting Room Layout

60 m² (645 ft²)

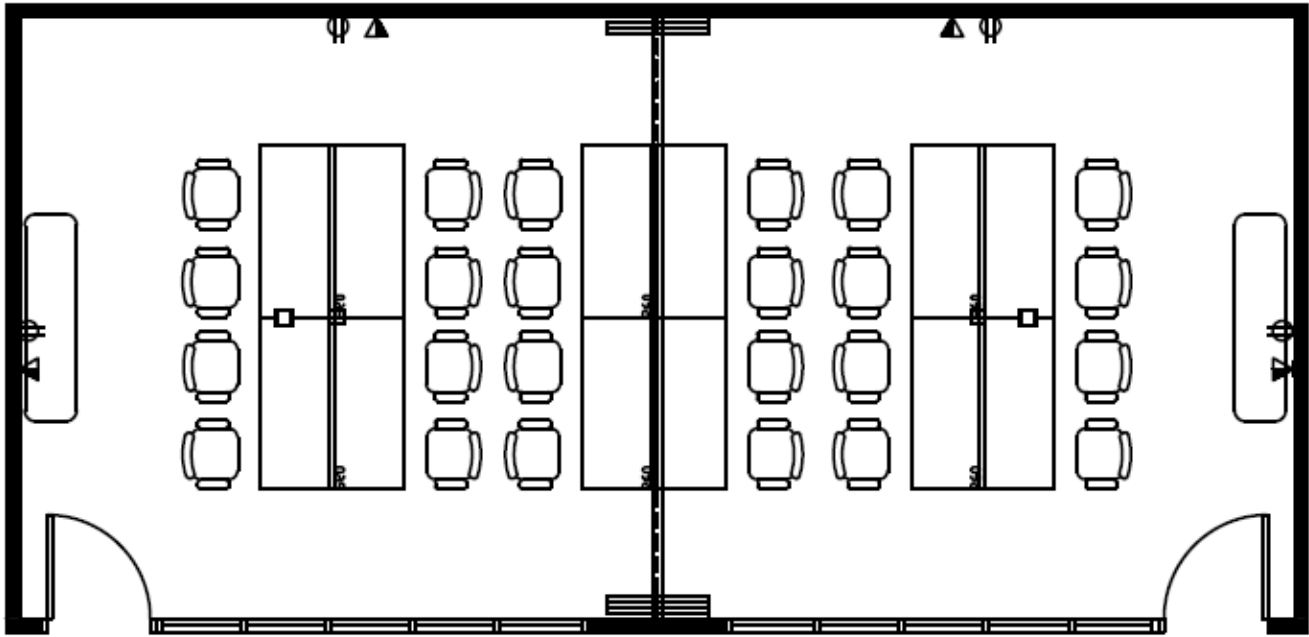

Note: □ Power and data recessed floor monument

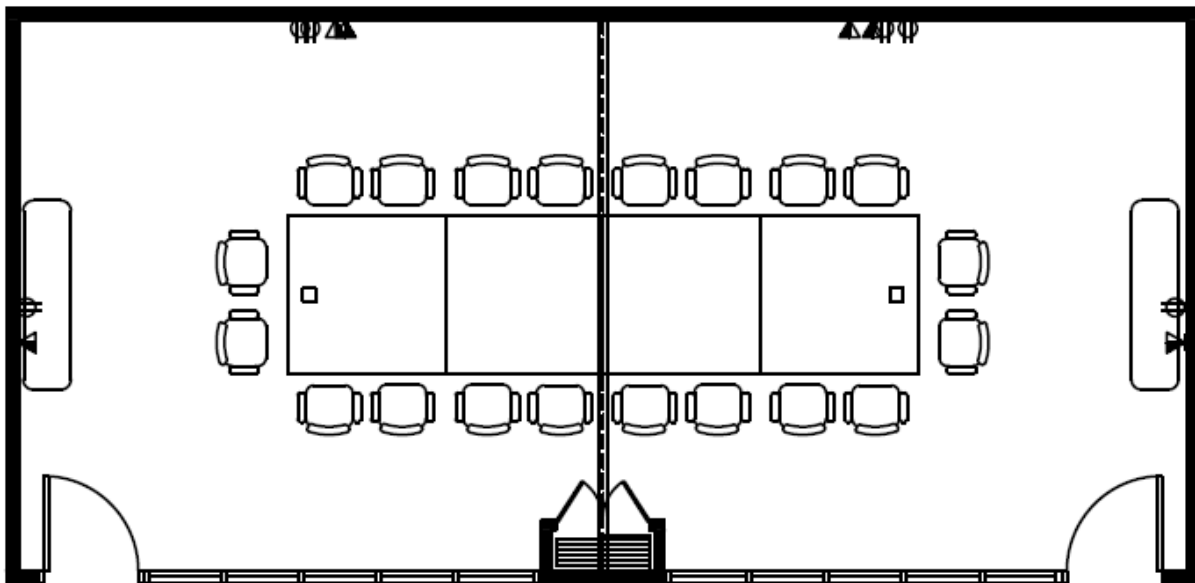

Note: □ Power and data recessed floor monument

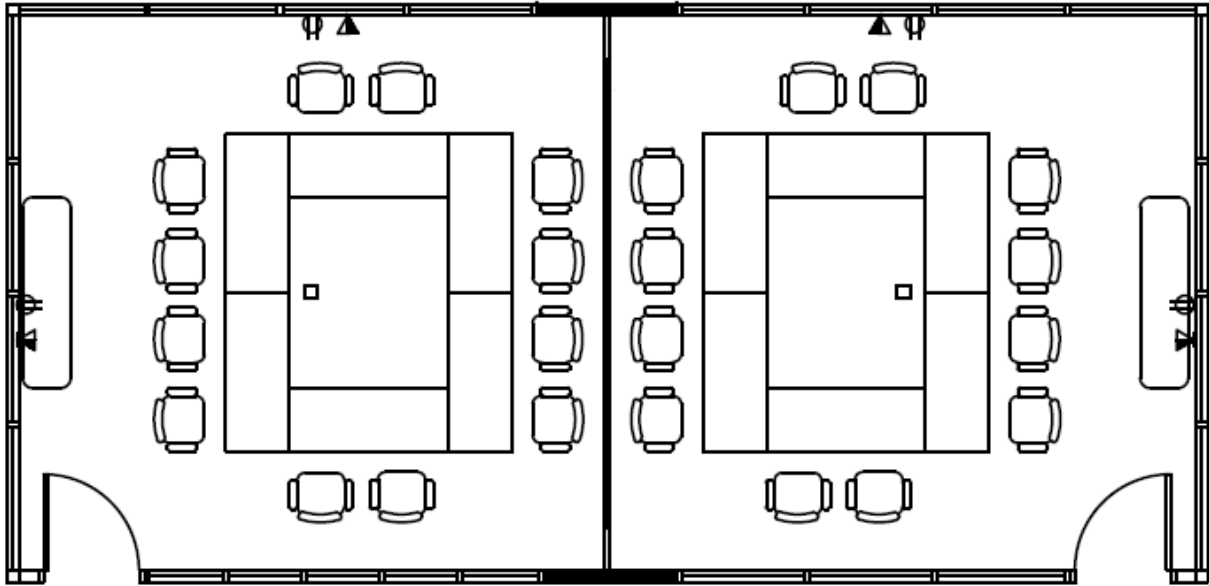

Note: □ Power and data recessed floor monument

Example of Reflected Ceiling Plan

60 m² (645 ft²)

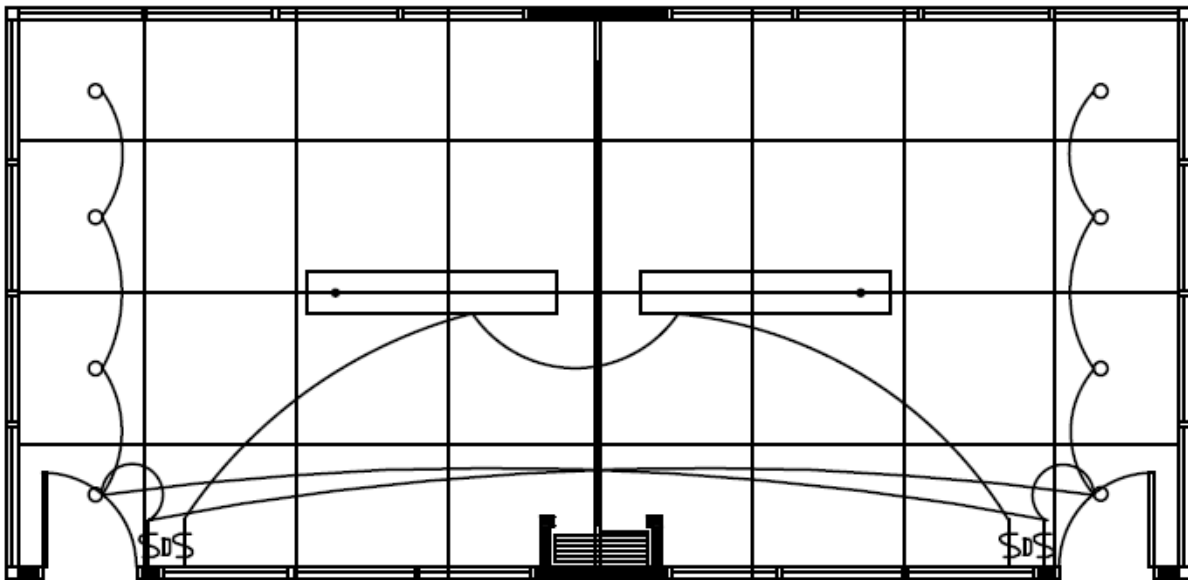

Quiet Room

5 m² (54 ft²)

Summary

Quiet rooms accommodate freestanding work surfaces suitable for a computer and telephone and should be barrier free.

Standard Finishes

- Floor – base building standard carpet (carpet tile or rolled goods)
- Walls – paint or unfinished to suit substrate

Standard Electrical Requirements

- 2 standard electrical duplex receptacles (1 circuit)
- 1 image/voice/data outlet
(**Note:** client to provide actual connectors and jacks, typically RJ45 with multiple jacks.)
- Base building lighting (may be relocated) with 1 separate switch/light control (task lighting recommended) and motion sensor

Standard Mechanical Requirements

- Supply and return air diffuser(s)/grille(s)

Examples of Quiet Room Layout

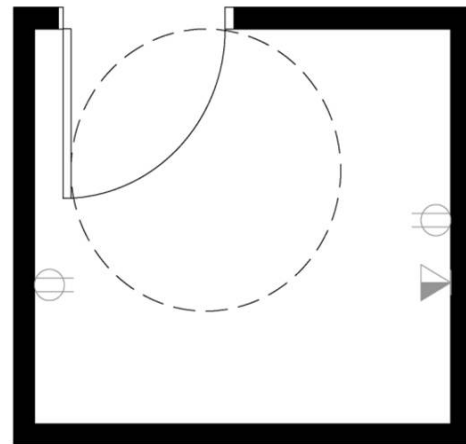
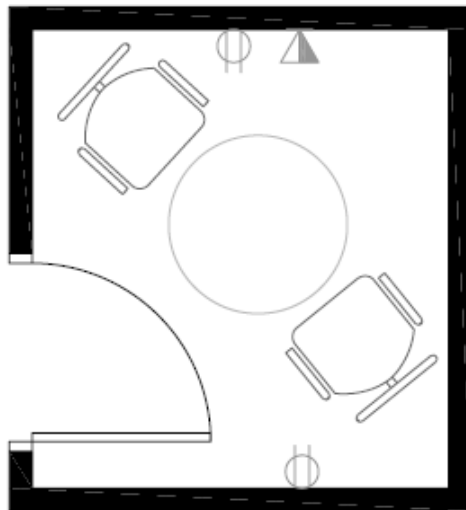
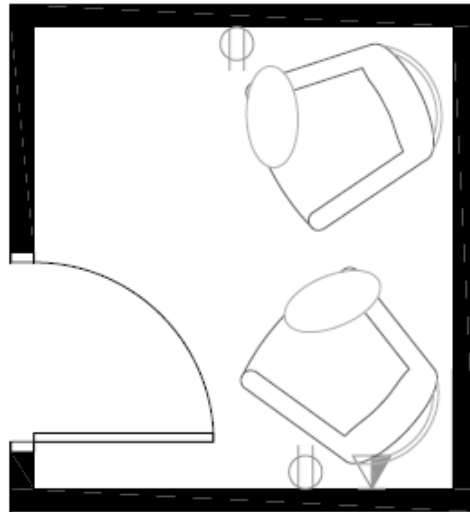
5 m² (54 ft²)

Kitchenette

Summary

The kitchenette accommodates average storage requirements, recycling centre and trash as well as a full size fridge and countertop appliances (appliances not included). Design allows for barrier-free access to sink. Millwork for upper and lower cabinets is provided and can be a freestanding manufactured solution if there is no cost differential. See A3.3 Fit-up Components and Funding Accountabilities for further details.

Standard Finishes

- Floor – resilient sheet or tile
- Walls – paint or unfinished to suit substrate
- Ceramic tile backsplash behind sink
- Millwork – See A7.1 Finishes

Standard Electrical Requirements

- 2 standard dedicated circuit duplex receptacles (microwave and fridge)
- 2 standard split circuit duplex receptacles for other countertop appliances (additional receptacle may be provided if required)
- Base building lighting with motion sensor
- 1 separate switch/light control for under cabinet lighting

Standard Mechanical Requirements

- Hot water, cold water, drain and vent piping for kitchen sink
- Kitchen exhaust fan c/w on/off switch (exhaust to exterior if economical and feasible)
- Supply air diffuser(s) and grilles(s)
- No return air to base building system

Example of Kitchenette Elevation

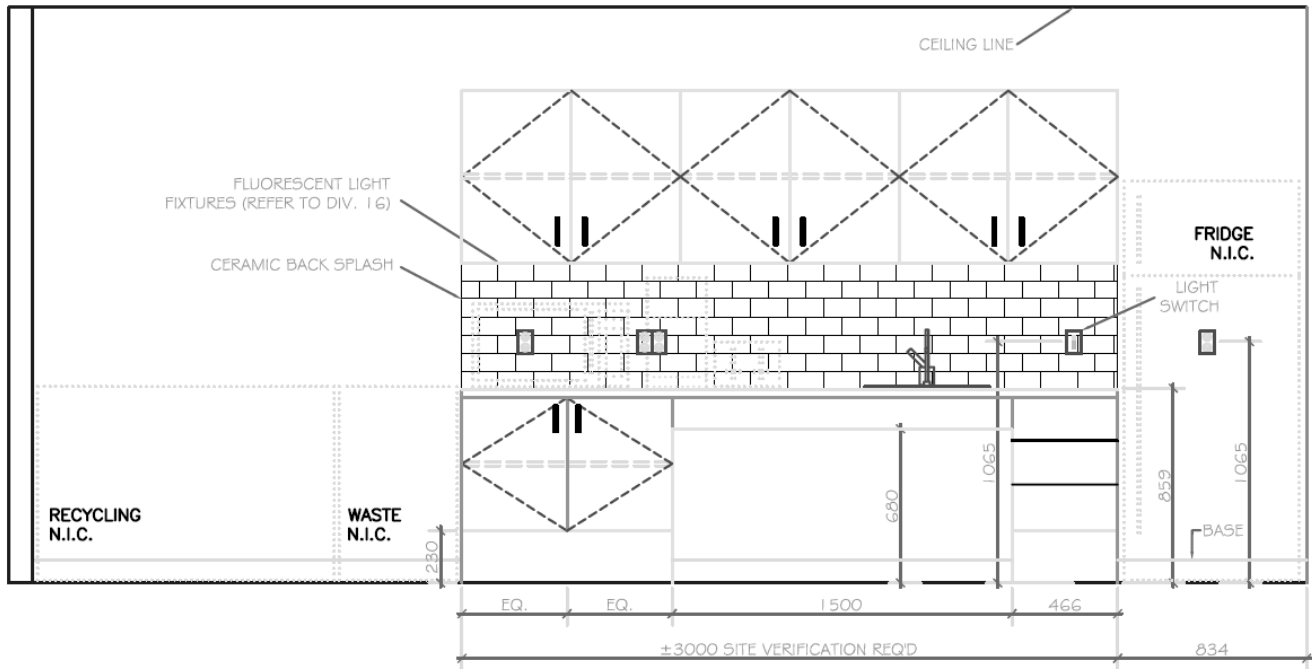

Shared Equipment Area

Summary

Area accommodates average requirements for storage, photocopier, printer and fax. Millwork for upper and lower cabinets is provided and can be a freestanding manufactured solution if there is no cost differential. See A3.3 Fit-up Components and Funding Accountabilities for further details. (Storage cabinet and equipment not included).

Standard Finishes

- Floor – resilient sheet or tile or base building standard carpet
- Walls – paint or unfinished to suit substrate
- Millwork – See A7.1 Finishes

Standard Electrical Requirements

- 3 electrical duplex receptacles to meet specific equipment needs
- 3 image/voice/data outlets
(**Note:** client to provide actual connectors and jacks, typically RJ45 with multiple jacks.)

Standard Mechanical Requirements

- Exhaust for photocopier to exterior
- Supply air diffuser(s) and grilles(s)

Example of Shared Equipment Area Elevation

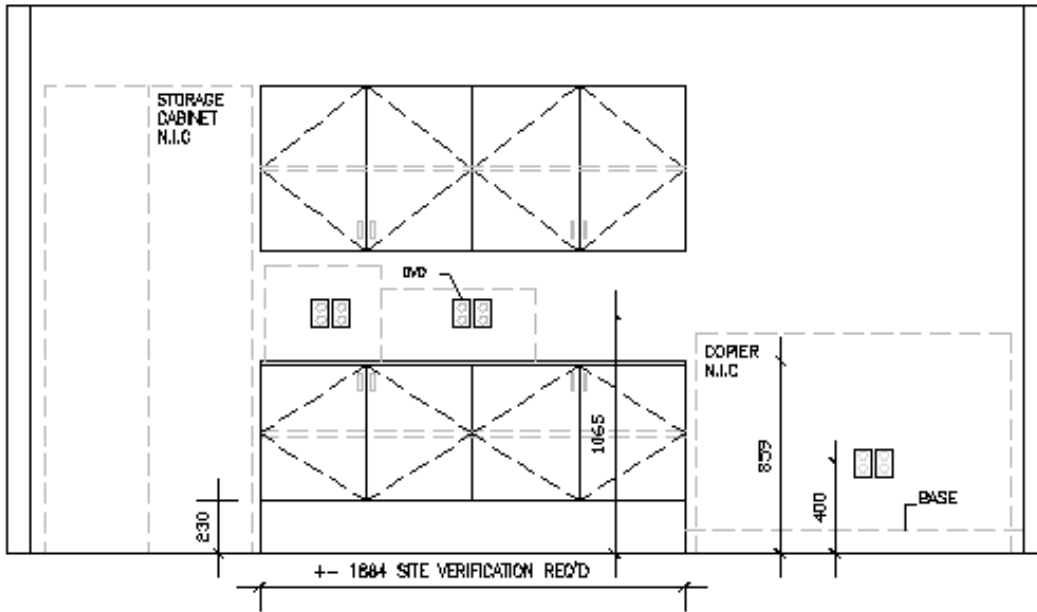

A6.3 Doors and Glazing

Example of Door with Sidelight – Office or Meeting Room

Note: Glazed doors (with frames) may be included as part of a reusable partition system (demountable/moveable) and may differ from examples below.

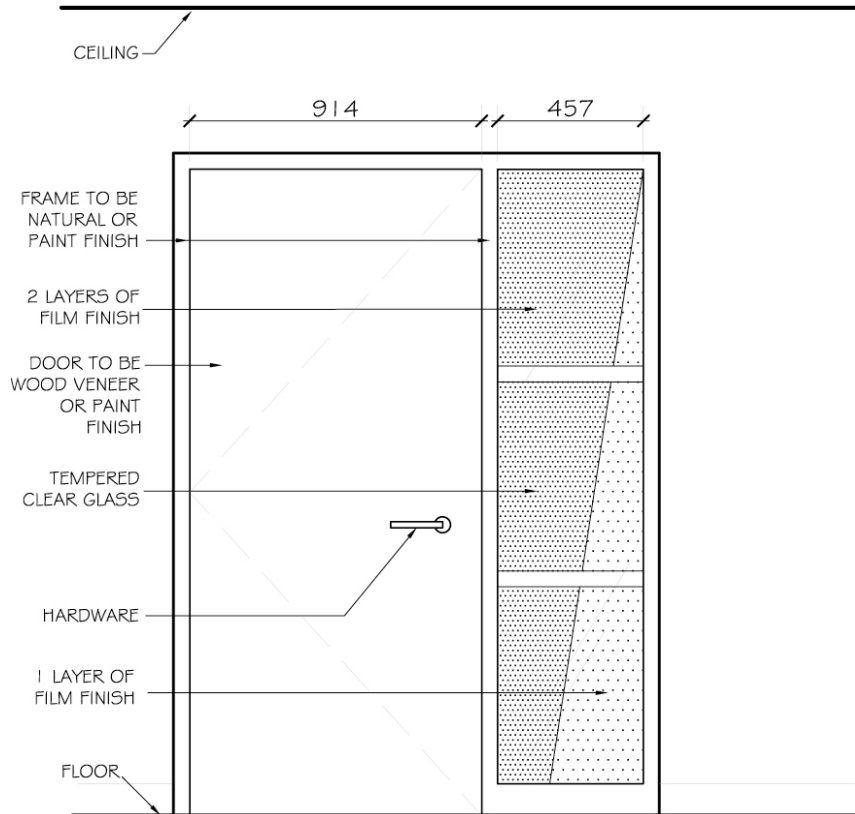

Note: Film treatment shown is example only. Pattern may vary but must endure change in occupancy. (No logos or departmental specific identification.)

Example of Door with Glazing – Office, Quiet Room or Small Meeting Room

Note: Glazed doors (with frames) may be included as part of a reusable partition system (demountable/moveable) and may differ from examples below.

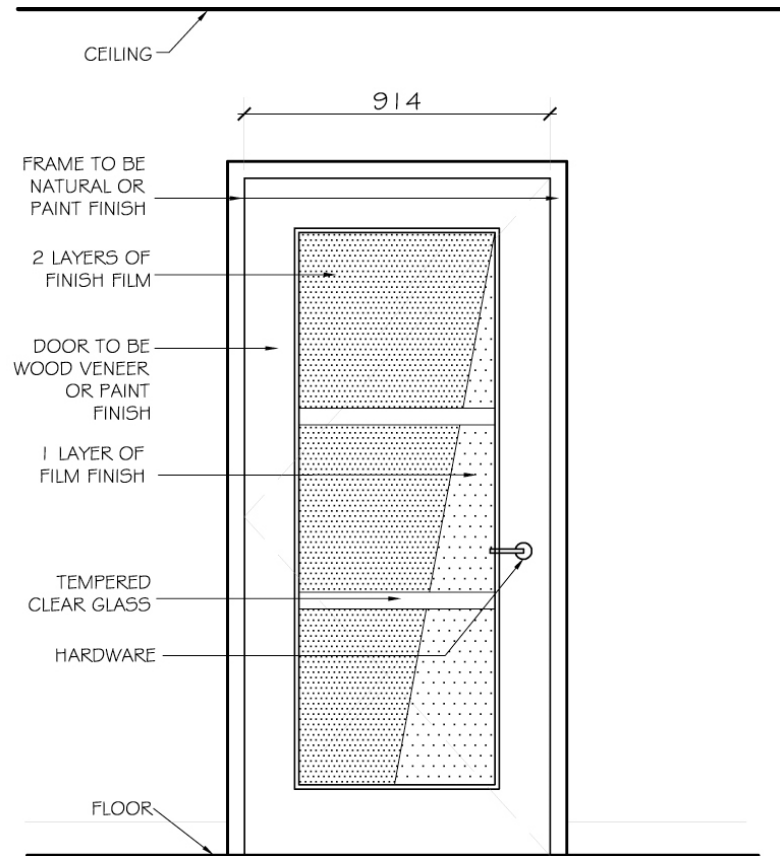

Note: Film treatment shown is example only. Pattern may vary but must endure change in occupancy. (No logos or departmental specific identification.)

Example of Door with Double Sidelight – Assistant Deputy Minister’s Office

Note: Glazed doors (with frames) may be included as part of a reusable partition system (demountable/moveable) and may differ from examples below.

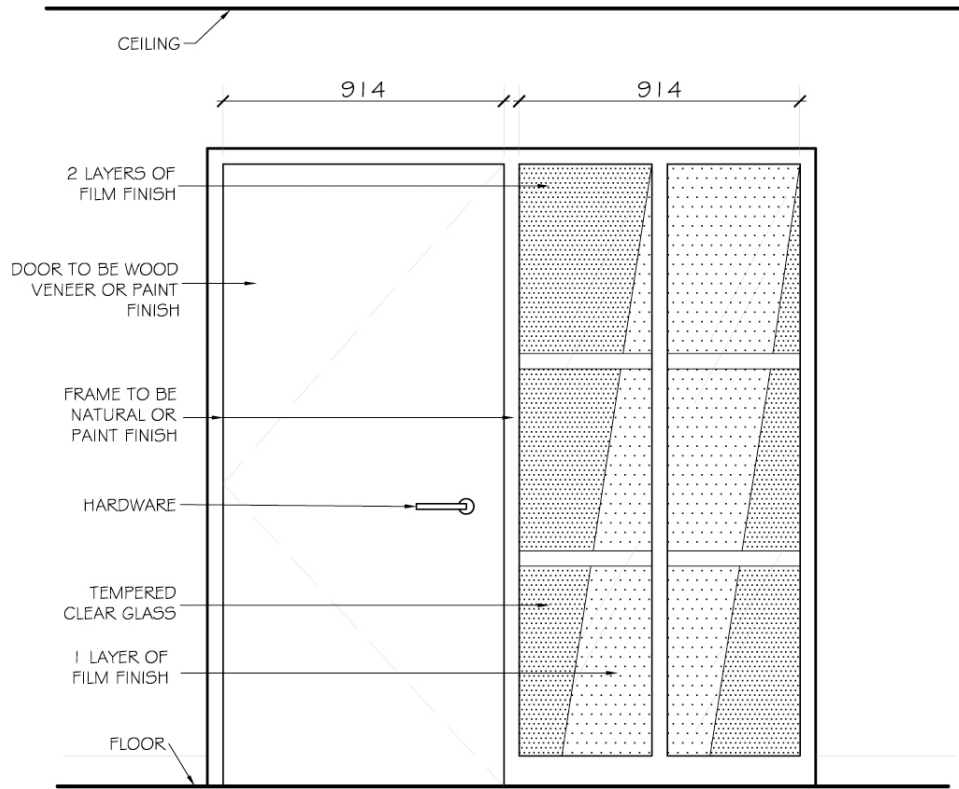

Note: Film treatment shown is example only. Pattern may vary but must endure change in occupancy. (No logos or departmental specific identification.)

Example of Door with Clerestory – Office, Resource Room or Similar Application

Note: Glazed doors (with frames) may be included as part of a reusable partition system (demountable/moveable) and may differ from examples below.

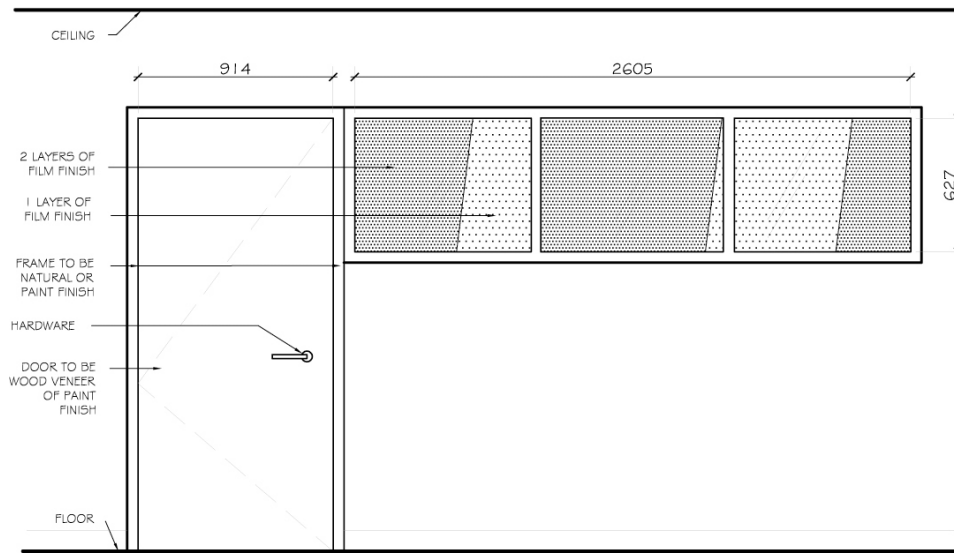

Note: Film treatment shown is example only. Pattern may vary but must endure change in occupancy. (No logos or departmental specific identification.)

A7. Finishes

Changes Since the Last Update

A7.1 Finishes

- ➔ Clarification that carpet tiles, rather than rolled goods are recommended.

A7.1 Finishes

The typical range of finish materials used in an office environment will achieve a variety of design concepts. Standard materials are of a midrange quality and are selected to attain sustainable design goals and provide best value for money based on a ten-year life-cycle costing analysis.

Selection Criteria

Finishes are chosen that meet the following sustainability criteria:

Durability and Recyclability: Durable materials will reduce maintenance costs and the amount of materials being sent to landfill. A high recycled content, durability and ease of recyclability should be considered when selecting materials. The use of salvaged materials should also be considered.

Low Embodied Energy: The energy required to produce and ship materials is the embodied energy of the product. Locally produced materials, with low embodied energy are preferable.

Low Toxicity: Many new materials have known toxicities, which off-gas into indoor environments. Material Safety Data Sheets from manufacturers provide information on the toxicity of products used. Alternative finishing products, made from renewable resources should be selected where possible.

Products should be certified by recognized third parties for environmental and quality management practices. The sustainability rating of a material must reflect a balance between each of the four sustainability principles, as the selection criteria can be contradictory. For example, steel takes considerable energy to produce, uses non-renewable resources and generates significant pollution, however it is very durable and in high demand for recycling. Sound research and judgment are required in making finish selections.

As the overall reduction of materials is of primary importance, consideration should be given to leaving substrate surfaces “unfinished” wherever suitable (e.g. concrete columns, storage room floors, wood beams).

Colour

Paint with low levels of volatile organic compounds (VOCs) should be utilized. A mix of lighter colours to reflect light, and accent colours to create interest and contrast may be used.

Carpet

Although floor finishes are generally a base building component, they are commonly selected and installed as part of a fit-up or refinishing project.

The use of both carpet tile and conventional roll goods (broadloom) is permitted, however, carpet tile is recommended as it is sustainable, reduces waste and eases maintenance as soiled or worn areas can be changed easily. While the initial cost for carpet tile may be greater, the life-cycle cost is far cheaper than rolled goods. Specifications for carpet selection are available from Architecture and Interior Design, Technical and Professional Services, PWGSC.

Millwork

Standard plastic laminate is normally selected for countertops because of its durability. Alternatives such as engineered wood products and local wood millwork products may be considered for vertical surfaces or as substrates for plastic laminate, if available at a comparable cost. Local wood millwork products include but are not limited to: stain or paint grade solid wood, No Added Urea Formaldehyde Medium Density Fiberboard (MDF), No Added Urea Formaldehyde particleboard, composite wood and wood veneer.

To ensure environmental sustainability, sourcing wood from sustainably managed forests such as those certified under the Forest Stewardship Council International (FSC International) or the Program for the Endorsement of Forest Certification Schemes (PEFC International) should be considered where available.

Further information about forest certification systems is available on the [Sustainable Forest Management in Canada Web site](#).

A8. Costing

Changes Since the Last Update

- A8.1 Workplace 2.0 Fit-up Rates
 - ➔ New rates for 2012-2013
- A8.3 Cost Estimates
 - ➔ New cost estimate sample for fit-up projects.

A8.1 Workplace 2.0 Fit-up Rates

Following are the Workplace 2.0 Fit-up Rates for 2012-2013.

The fit-up rates are provided for two office space categories: general administrative offices as well as Ministerial and Deputy Head Accommodation. Rates are provided in usable square metres (um²) and rentable square metres (rm²).

The rates were established from a detailed analysis of fit-up costs completed in 2012. They are based on planning examples and current market conditions in major centres across the country.

The rates are to be used to determine indicative estimates for fit-up of general administrative and public contact office space where more specific costing data is not available. In addition, they will continue to serve as *maximum limits* for the purpose of determining PWGSC's funding accountability for special purpose space. Please note, however, that for general administrative, public contact as well as quasi-judicial office space, PWGSC will fund the standard Workplace 2.0 fit-up components for general-purpose office space (also known as the "bundle of goods") as described in A1.1 of the *Workplace 2.0 Fit-up Standards*. All fit-up components that exceed the Standards must be funded by the client department.

The rates for general administrative offices are scaled according to two ranges of space size, and are provided for major urban centres across the country. Regions may adjust these costs for centres not identified in the tables, based on knowledge of local construction costs and market conditions.

The rate for ministerial and deputy head accommodation is provided for the National Capital Area (NCA). It has been established as a *maximum limit* for determining PWGSC's funding accountability for the fit-up of office suites for ministers in departmental headquarters and for deputy heads.

General Administrative Offices

City	2012-13 Indicative Estimate			
	<1,500 m ²		>1,500 m ²	
	\$/um ²	\$/rm ²	\$/um ²	\$/rm ²
St. John's, N.L.	591	525	508	451
Halifax, N.S.	634	563	541	480
Montreal, Que.	675	600	573	509
Ottawa, Ont.	688	611	584	519
Toronto, Ont.	713	633	603	536
Winnipeg, Man.	670	595	569	505
Regina, Sask.	652	579	555	493
Calgary, Alta.	682	605	578	513
Edmonton, Alta.	654	581	556	494
Vancouver, B.C.	685	609	581	516
Whitehorse, Yukon	795	706	666	592
Yellowknife, N.W.T.	752	668	633	562
Inuvik, N.W.T.	874	777	728	647
Iqaluit, Nunuvut	1,008	896	833	740

Ministerial and Deputy Head Accommodation

City	2012-13 Maximum Limit	
	<1,500 m ² \$/um ²	<1,500 m ² \$/rm ²
NCA	1,640	1,457

Note: Conversion of usable rates into rentable rates: usable rate divided by 1.1256.

A8.2 Source of Funds for Non-compliant Workplace 2.0 Fit-up Components

The PWGSC Real Property business line budget is funded to fit-up office space to meet general administrative and public contact operational requirements. The Real Property Program is not resourced to cover the cost of special fit-up requirements for quasi-judicial offices, secure administrative offices and special purpose space. Therefore, a source of funds must be identified to cover the difference between the cost of providing general-purpose office space and the client's special requirements. This responsibility lies with client departments and agencies; however, PWGSC as a real property expert and a common service provider, can support them in their discussions with Treasury Board Secretariat.

Client departments and agencies must document their specific requirements for accommodation and additional funding in a business case so that they can be appropriately considered for funding either within their own operational budget or through a submission to Treasury Board. PWGSC can assist with:

- The confirmation of department/agency fit-up requirements;
- The identification of fit-up elements and level of service (soft costs) above standards;
- The provision of cost estimates; and
- The recognition that additional funding is required (above PWGSC's funded standards) and that securing these funds is a client department/agency accountability.

Should additional funding be required, there are two potential sources of funds:

- The client department/agency's current operating budget; or
- Treasury Board (new money).

Once the source of funds is determined, several payment options can be explored. For example:

For space replacement projects

- If the source of funds is Treasury Board, the new funding can be directed to the client's budget or to PWGSC; or
- If the source of funds is the client, the client can pay by means of a Specific Service Agreement (SSA) or request an operating budget transfer to PWGSC via ARLU or Supplementary Estimates.

For expansion projects

- If the source of funds is the new approved program, the accommodation levy (13%) could be increased to a percentage that would recognize the additional costs or through a fully costed Treasury Board submission.

A8.3 Cost Estimates

Project Managers and Project Officers are requested to follow the format shown in the example below when preparing their cost estimates for fit-up projects. This breakdown will help to determine those types of fit-up elements that are more often associated with increased costs.

This costing example is based on Plan Example in A5.2 Sample Plans, PL1 diagram. A blank version of this form is available in A9.1 Workplace 2.0 Fit-up Cost Estimate Template.

Generic Fit-up (National Capital Area)

Summary (usable floor area: 1,749.1 m²)

Fit-up Component	Total Cost Estimate	\$/m ²
Partitions	159,168	91
Doors and Frames (including hardware)	41,978	24
Finishes	73,462	42
Millwork and Specialties	33,233	19
Plumbing	19,240	11
HVAC	66,466	38
Fire Protection	33,233	19
Electrical	113,692	65
General Requirements*	80,459	46
Panels/screens (including service conduits, power receptacles and voice/data outlets)	400,544	229
Fit-up Total	1,021,475	584

* Includes insurance, bonding, site office and supplies, site safety and security and materials handling.

Note:

- Estimate based on 2012-2013 cost data.
- Costs exclude post contract contingencies.
- Costs exclude GST and HST.

Variables that could impact on fit-up costs include, but are not limited to:

- Project size;
- Open workstation/closed office and support space ratio;
- Ceiling heights;
- Specific detailing of partition assemblies;
- Specific design features;
- The inclusion of “atypical” support spaces (e.g., first-aid room, primary reception area, etc.);
- Existing conditions (e.g., need to relocate a fire extinguisher or fire hose cabinet, a non-uniform layout of sprinklers or air supply/returns, etc.); and
- Region/municipality (e.g., the cost of developing office space is generally higher in Toronto than in Winnipeg).

A8.4 Additional Direct and Indirect Costs

When project parameters are in compliance with the PWGSC accommodation policies and fit-up standards, there are a number of additional direct and indirect costs considered to be part of the project delivery and funded by PWGSC. As indicated in the table below, some of the standard items/activities are included in the fit-up cost limits while others must be programmed separately through Building Management Plans (BMPs) or otherwise identified at the time of the project. Costs for items/activities under the responsibility of client departments/agencies are also identified below:

Other Items/Activities Inherent to Fit-up Projects		Funding Accountabilities		
		Fit-up Cost Limit	Other Project Costs	Client Cost
A	Other Direct Costs			
	<ul style="list-style-type: none"> Building and occupancy permits, as required. 		Yes	
	<ul style="list-style-type: none"> Contractor's overhead and profit. 	Yes		
	<ul style="list-style-type: none"> Commissioning – component systems and integrated systems performance testing, training, commissioning documentation including building management manual, as built, balancing, etc. 	Yes	Yes	Yes
	<ul style="list-style-type: none"> Development of the functional program (see R1. Glossary). 			Yes
	<ul style="list-style-type: none"> Dismantling, moving and reassembling computer, telecommunications and other specialized equipment or furnishings (e.g., fine art). 			Yes
	<ul style="list-style-type: none"> Moving supplies and services. 		Yes	
	<ul style="list-style-type: none"> Return to initial state at end of lease or demolition in Crown-owned facilities – all standard fit-up components. 		Yes	
	<ul style="list-style-type: none"> Return to initial state at end of occupancy – all nonstandard items initially paid for by the client (e.g., washroom for specific tenant use). 			Yes
	<ul style="list-style-type: none"> Security guards for after hours work in occupied space. 			Yes
	<ul style="list-style-type: none"> Security guard services or other expenses related to client's security needs. 			Yes
	<ul style="list-style-type: none"> Space measurement. 		Yes	
	<ul style="list-style-type: none"> Trade costs specifically related to the construction contract. 	Yes		
B	Consultant Fees (Direct "Soft" Costs)			
	<ul style="list-style-type: none"> Professional consulting fees for architectural, interior design, code review (if HRSDC cannot provide service), mechanical, electrical and structural engineering services. 		Yes	
	<ul style="list-style-type: none"> Fees and other costs related to additional design reviews and specialized requirements (see A8.5). 			Yes
C	Other Fees (Direct "Soft" Costs)			
	<ul style="list-style-type: none"> Lessor management fee for soft costs. 		Yes	
	<ul style="list-style-type: none"> Lessor management fee for construction. 		Yes	
	<ul style="list-style-type: none"> Lessor's fee related to portion funded by the client. 			Yes

Other Items/Activities Inherent to Fit-up Projects		Funding Accountabilities		
		Fit-up Cost Limit	Other Project Costs	Client Cost
D	PWGSC Fees (Indirect Costs)			
	• PWGSC accommodation planning and design fee.		Yes	
	• PWGSC project management fee.		Yes	
	• PWGSC project leadership fee.		Yes	
	• PWGSC construction supervisory fee.		Yes	
	• PWGSC's fee for other services, as required.		Yes	
	• PWGSC's fee related to portion funded by the client.			Yes
E	Operation and Maintenance Cost			
	• Standard base building, cleaning and maintenance services as described in the Occupancy Instrument.		Yes	
	• Maintenance and other fees associated with client funded fit-up components.			Yes
	• Additional base building and cleaning services.			Yes

A8.5 Project Delivery Cost Controls

It is not only the fit-up project, but also the process for delivering a fit-up project, that must be controlled to help constrain costs. Extensive changes or numerous revisions during the planning and design stages risk causing delays in the project schedule as well as overruns in the budget.

In order to ensure more timely and cost effective delivery of fit-up projects, the following controls and funding accountabilities will apply:

- The “two revision rule” – The *Workplace 2.0 Fit-up Standards* allow a maximum of two client requested revisions per deliverable during the schematic and design development stages prior to final approval. Anything over this limit is non-standard and billable to the client. (**Note:** If the two revisions are not used at one stage, there is no provision to carry the allowance over to a subsequent stage.)
- Costs related to delays in reviewing and approving project documents (drawings, specifications) are billable to the client.
- Costs related to design changes requested following the design development stage (including design, management fees and the cost of delays during the construction drawing stages and all costs resulting from changes requested during the construction or post occupancy stages) are billable to the client.
- Costs related to implementing client requested revisions to previously approved (signed off) documents are billable to the client.
- Additional design and management services generated by specialized or enhanced client requirements, including accelerated project delivery, are billable to the client.

A “client requested revision” is deemed to be a requirement or preference not previously identified, that necessitates a substantial re-examination of completed work (such as reworking of previous drawings and/or project documents), in order to find a solution that would accommodate the new requirement.

Minor adjustments to drawings that do not have substantial impact on other areas, such as relocating a door or reorienting a workstation, are not considered a “revision” relative to the “two revision rule”. Similarly, work that is deemed by the project manager to be contractually incomplete or non-compliant with the standards is not considered a client responsibility.

A9. Forms and Templates

Changes Since the Last Update

A9.4 Workplace 2.0 Worker Profile Identifier

A9.5 Workplace 2.0 Space Allocation Standards Calculator

A9.1 Workplace 2.0 Fit-up Cost Estimate Template

Project Managers and Project Officers are requested to follow the format shown below when preparing their cost estimates for fit-up projects. This breakdown will help to determine those types of fit-up elements that are more often associated with increased costs.

Project No.: _____

Name: _____

Usable Floor Area: _____

Summary:

Fit-up Component	Total Cost Estimate	\$/m ²
Partitions		
Doors and Frames (including hardware)		
Finishes		
Millwork and Specialties		
Plumbing		
HVAC		
Fire Protection		
Electrical		
General Requirements		
Panels/screens (including service conduits, power receptacles and voice/data outlets)		
Fit-up Total		

* Includes insurance, bonding, site office and supplies, site safety and security and materials handling.

Variables that could impact on fit-up costs include but are not limited to:

- project size;
- open workstation/closed office and support space ratio;
- ceiling heights;
- specific detailing of partition assemblies;
- specific design features;
- the inclusion of “atypical” support spaces (e.g., first-aid room, primary reception area, etc.);
- existing conditions (e.g., need to relocate a fire extinguisher or fire hose cabinet, a non-uniform layout of sprinklers or air supply/returns, etc.); and
- region/municipality (e.g., the cost of developing office space is generally higher in Toronto than in Winnipeg).

A9.2 Workplace 2.0 Fit-up Compliance Monitoring Form

Date:

Project Summary	
Project Title:	
Building Name/Address:	
Client Department:	
Building Cost Centre:	Project Number:
Project Size (um ²):	Project Type/Qualifier:
Office Space Type:	Project Cost Estimate:
Date Space Required:	Source of Funding:
Term of Occupancy:	Project Status:

PWGSC Project Team
Project Leader:
Accommodation Manager:
Project Manager/Officer:
Design Manager:
Property and Facilities Manager:

Non-compliance Requirement:
Description:
Has the project team determined that ADM approval is required? (Yes/No)
If no, document decision of project team and rationale.

Non-compliant Component	Cost Estimate	Supported by Project Team (Yes/No)	ADM RPB Approved (Yes/No)
Total Cost Estimate:			

Contacts:		
PWGSC	Name and Title:	Phone/Fax Number:
Client	Name and Title:	Phone/Fax Number:

A9.3 Business Case Template

Cover Page

[Name of department or agency]

Business case

For

[Project-specific non-compliant fit-up requirements or program-specific accommodation requirements]

[Title]

Submitted by:

[Name, title, section and branch]

Submitted to:

Assistant Deputy Minister, Real Property Branch,
Public Works and Government Services Canada

Date: [day/month/year]

Business Case

General Instructions: It is important that the business case be clear, concise and complete. Include only relevant information and avoid duplication. A maximum of 3 pages per item being requested, not including appendices, should be sufficient for most submissions.

Purpose

Provide a brief statement on the purpose of the business case (i.e., the non-compliant item(s) or national special purpose space for which approval is being requested).

Background/Context

Provide background information as it relates to the request. Normally, this section requires two to three paragraphs only and may include, for example:

- a) Mandate of the department or agency and/or the specific group or program to which the request applies;
- b) Strategic considerations e.g., broader government objectives;
- c) If the request is project-specific, a brief description of the project and work completed to date. Include, as an appendix, the completed Workplace 2.0 Fit-up Standards Compliance Monitoring Form; and/or
- d) If the request is program-specific, a list of locations to which the request applies including address, area (usable and rentable m²) and population.

Request(s) for Non-compliant Fit-up

For each non-compliant fit-up item being requested, provide the following information.

1. [Non-compliant fit-up item]

Issue:

Describe the main issue(s) or problem(s) driving the request and any impact(s) on the department's or agency's operations.

Options Analysis:

Provide an analysis of all options considered for addressing the issue(s). (NB: The *Workplace 2.0 Fit-up Standards* must be considered as one of the options.) For each option, include the following:

- a) Brief description of the option;
- b) Gap analysis;
 - i) Gap between the option and:
 - ⇒ The *Workplace 2.0 Fit-up Standards* (components and allocations); and
 - ⇒ The *Space Allocation Standards* (usable m²); and
 - ii) Impact of the gap on costs in terms of:
 - ⇒ Fit-up;
 - ⇒ Rent; and
 - ⇒ Ongoing operation and maintenance.

Short term and, where appropriate, long term impacts must be considered. Details are to be provided in the appendix, as required.

Note: Include template, as appropriate.

- c) Benefits and risks in relation to, for example:
 - i) Operational requirements and/or program delivery;
 - ii) Government objectives and priorities;
 - iii) Security;
 - iv) Health and safety;
 - v) Sustainability;
 - vi) Project delivery and schedule; and
 - vii) Other.

Recommendation and Justification:

Provide a clear statement of the solution being recommended for approval and the basis for the justification.

- a) When the recommendation is based on legislation, Treasury Board policies or approvals, reports or studies, the justification must include specific reference to the relevant text within the document. The document, or excerpts from it, must be included as an appendix, where appropriate.

- b) When the recommendation is based on security, the justification must include:
- i) Reference to text within a third party Threat and Risk Assessment, Security Design Brief or Security Site Brief that specifically supports the request. If these documents are not available, they must be developed before the business case is submitted.
 - ii) In the case of project-specific requests, if there is sufficient reason for not developing any of the above-noted documents, a letter from the Departmental Security Officer must be provided and include, where appropriate:
 - ⇒ a statement of the security requirement necessitating the non-compliant fit-up;
 - ⇒ an explanation as to why zoning is not an acceptable alternative;
 - ⇒ the security classification of the information being handled i.e., Confidential, Secret, Top Secret, Protected A, B, or C; and
 - ⇒ legal liabilities.
- c) When the recommendation is for enclosed offices, the justification must include:
- ⇒ the category and level of the position to which the request applies;
 - ⇒ the responsibilities of the position; and
 - ⇒ an organization chart.
- d) When recommendation is for additional enclosed offices or support spaces, the justification must include an explanation as to why the standard support space allowances cannot address the requirement, including:
- ⇒ frequency and duration of activities for which the enclosed space is required; and
 - ⇒ use of all undesignated support space allowances.

Request(s) for National Special Purpose Space

Include this section with program-specific requests, as required.

1. [National Special Purpose Space being requested]

For each national special purpose space request, provide the following information.

Issue:

Describe the main problem(s) or issue(s) driving the request and the impact the issue is having on the department's or agency's operations.

Options Analysis:

Provide an analysis of all options considered for addressing the issue(s). For each option, include the following:

- a) Brief description of the option;
- b) Impact on cost in terms of fit-up, rent and ongoing operation and maintenance. Short term and, where appropriate, long term impacts must be considered. Details are to be provided in the appendix, as required; and
- c) Benefits and risks in relation to, for example:
 - i) Operational requirements and/or program delivery;
 - ii) Government objectives and priorities;
 - iii) Security;
 - iv) Health and safety;
 - v) Sustainability;
 - vi) Project delivery and schedule; and
 - vii) Other.

Recommendation and Justification:

Provide a clear statement of the solution being recommended for approval including space and fit-up requirements, and the basis for the justification.

- a) When the recommendation is based on legislation, Treasury Board policies or approvals, reports or studies, the justification must include specific reference to the relevant text within the document. The document, or excerpts from it, must be included as an appendix, where appropriate.

Funding

Include the following statement(s) to confirm the department's or agency's accountability for associated costs:

- a) For non-compliant fit-up requests: "[Client department or agency] is responsible for the cost of all items associated with this non-compliance request that exceed the approved space envelope, and *Government of Canada Workplace 2.0 Fit-up Standards*, including rent, fit-up and related ongoing operation and maintenance."
- b) For special purpose space requests: "[Client department or agency] is responsible for the cost of all items associated with this special purpose space request that exceed the approved space envelope, the *Government of Canada Workplace 2.0 Fit-up Standards* "bundle of goods" and the Fit-up Rate, including rent, fit-up and related ongoing operation and maintenance."

Appendices

- a) Workplace 2.0 Fit-up Standards Compliance Monitoring Form (mandatory for project-specific non-compliance fit-up requests);
- b) Other documents as appropriate, for example:
 - i) Detailed gap analysis;
 - ii) Legislation, TB policies, TB minutes, reports, studies;
 - iii) Floor plans;
 - iv) Threat and Risk Assessment, Security Design Brief, Security Site Brief, or letter from the Departmental Security Officer;
 - v) Organization charts;
 - vi) Functional program; and/or
 - vii) Draft program-specific standards (for program-specific requests only).

A9.4 Workplace 2.0 Worker Profile Identifier

The Workplace 2.0 Worker Profile Identifier has been developed to assist in the identification of worker profiles. This questionnaire can be found at the following URL:

http://www.gcpeia.gc.ca/wiki/Fit-up_Standards.

A9.5 Workplace 2.0 Space Allocation Standards Calculator

The Workplace 2.0 Space Allocation Standards Calculator has been developed to assist in the determination of the maximum space allocations to be applied when planning, acquiring and monitoring use of office accommodation provided by PWGSC to client departments. This tool is available at the following link: http://www.gcpeia.gc.ca/wiki/Fit-up_Standards.



Section B:

Guidelines for Ministerial and Deputy Head Accommodation



B1. Introduction

B1.1 General Information

Overview

The following guidelines have been developed to address the special fit-up requirements of ministerial and deputy head office accommodation as provided by PWGSC. They adopt the generic approach of the standards for general administrative office space (Section A) with some exceptions, the most notable of which are size and location of offices, provision of private washrooms and dedicated support space, and modifications to wall finishes, lighting and kitchenette millwork.

Application

These guidelines apply to accommodation for ministers and ministers of state and their staff in departmental headquarters offices (see [TB Guidelines for Ministers' Offices, Part 3 Human Resource Management](#)), and for deputy heads and their staff, including associate deputy ministers. Ministerial and deputy head offices are accommodated within the space envelope of the client department or agency and are **not** designated as special purpose space (SPS).

Please note, these guidelines do not apply to ministers' space on Parliament Hill, Constituency Offices, Ministers' Regional Offices (MROs) or to heads of quasi-judicial organizations.

Approvals and Governance

Approval of standards for ministerial and deputy head accommodation ultimately rests with the Minister of Public Works and Government Services Canada (PWGSC). Ministers' departmental headquarters offices are also subject to Treasury Board Guidelines for Minister's Offices while deputy heads' offices are subject to the PWGSC *Framework for Office Accommodation and Accommodation Services*.

The client department must provide justification for all requirements that exceed the guidelines to the satisfaction of the PWGSC project team.

B2. Guidelines

B2.1 Fit-up Components and Funding Accountabilities

The following chart identifies fit-up components and funding accountabilities related to the special fit-up requirements for ministerial and deputy head office suites. These components are provided in addition to those provided for general administrative office space as described in A3.3 Fit-up Components and Funding Accountabilities for the components are as follows:

- Base building components are funded by PWGSC;
- Fit-up components for non-reimbursing clients are funded by PWGSC up to the fit-up rates for Deputy Ministerial and Ministerial Offices (see A8.1);
- Fit-up components for reimbursing clients and Expansion Control Framework are funded by the client department or agency;
- Other components are funded by the client department or agency, including all related commissioning, testing and ongoing maintenance.

PWGSC is responsible for initial fit-up of the space. Changes to existing offices during the term of an occupancy (e.g. during a minister's or minister of state's tenure or on appointment of a new minister or minister of state) are funded by the department or agency as a tenant service.

Components		Base Building	Fit-up Standards	Other
A	Interior Construction			
	1. Partition Walls			
	(a) <i>Offices for ministers</i>		Yes	
	(i) Slab to slab construction with or without vestibule ¹ (secure speech privacy).			
	(b) <i>Offices for deputy heads and associate deputy ministers</i>		Yes	
	(i) Slab to underside of ceiling with insulation and plenum barriers ¹ (enhanced speech privacy).			
	(ii) Slab to slab construction with or without vestibule (secure speech privacy as determined by the Departmental Security Officer ¹).			Yes ²
	(c) <i>Offices for ministerial exempt staff</i>			Yes ²
	(i) Slab to underside of ceiling with insulation and plenum barriers ¹ (enhanced speech privacy).			
	2. Door hardware			
(a) <i>Offices and private washrooms for ministers – mortise (keyed) lock set and lever trim (handle) on office entry and washroom doors.</i>		Yes		
(b) <i>Private washrooms for deputy heads – cylinder with thumb turn lock.</i>		Yes		

Components		Base Building	Fit-up Standards	Other
3. Interior specialties				
(a)	Private washrooms for ministers and deputy heads – three-piece washroom including built-in shower, vanity, storage and accessories as allocated in B2.2 and as illustrated in B4.1.		Yes	
(b)	Kitchenettes and shared equipment areas for ministers’ and deputy heads’ suites – additional millwork as allocated in B2.2 and illustrated in B4.2 to accommodate dishwashers and other special requirements.		Yes	
4. Interior finishes				
(a)	Wall/base finishes			
(i)	Offices for ministers, deputy heads and associate deputy ministers – paint or unfinished to suit performance requirements and substrate, two wall surfaces may be finished in midrange quality wall covering.		Yes	
(ii)	Private washrooms for ministers and deputy heads – ceramic tile in shower surround and above basin, as required.		Yes	
B	Services			
1. Plumbing systems				
(a)	Private washrooms for ministers and deputy heads – all related fixtures and services required for three-piece washroom with built-in shower.		Yes	
2. Heating, ventilation and air conditioning systems				
(a)	Ministerial and deputy head suites – modifications to base building system or independent system to meet requirement for 24/7 operations.		Yes	
3. Electrical systems				
(a)	Power Emergency power in support of 24/7 operations.			Yes ²
(b)	Lighting Offices for ministers, deputy heads and associate deputy ministers – lighting modifications to suit office functions (including addition of parabolic louvers, relocation of base building lighting, addition of accent lighting). These modifications do not include the removal/upgrade of base building ceiling or lighting. (See B4.1 for examples).		Yes	

¹ Acoustic control may be adversely affected by perimeter HVAC units or other building perimeter conditions.

² Client cost – NOT subject to the non-compliance approval process

B2.2 Office and Support Space Allocations

The following notes and tables describe the special office and support space allocations for ministerial and deputy head suites. Where not otherwise stated below, allocations for ministerial and deputy head accommodation are provided in accordance with the standards for general-purpose office space as described in A3.4.

Office Space

Closed Offices for Ministers, Deputy Heads and Associate Deputy Ministers

See B4.1 for drawings that illustrate typical sizes and configurations of closed offices for ministers, deputy heads and associate deputy ministers, including standard mechanical and electrical requirements. The following table describes the maximum size allowances for these offices.

Positions	Maximum Area (um ²)
Ministers and Ministers of State	48 ¹
Deputy heads and associate deputy heads of departments and agencies, and equivalents (e.g. deputy ministers, associate deputy ministers)	37 ²

¹ Includes 3 m² vestibule for secure speech privacy.

² If secure speech privacy is required, add 3 m² for vestibule (client cost).

Offices may be located on perimeter walls. It is important to note, however, that acoustic control may be adversely affected by perimeter HVAC units or other building perimeter conditions.

Floor finish: base building standard carpet

Wall finish: paint or unfinished to suit substrate, one or two walls may be finished in mid-range quality wall covering

Lighting: base building (may be modified and relocated to suit) and accent lighting (optional) with separate switching

Private Washrooms

See B4.1 for drawings that illustrate the typical size, configurations and millwork allowances for private washrooms. Private washrooms are provided for ministers and deputy heads only. They are not allocated to associate deputy ministers. The standards include a three-piece washroom with built-in shower, vanity and storage. Provisions are as follows:

Maximum area: 9 m²

Millwork: 1,800 linear mm (6') of counter and storage

Floor finish: resilient sheet or ceramic tile

- Wall finish:** paint or unfinished to suit substrate, ceramic tile on shower surround and above basin
- Lighting:** wall mounted (sconce), recessed down lights and sealed shower light, all with separate switching

Offices for Ministerial Exempt Staff

Closed offices are provided for ministerial exempt staff in accordance with the office allocations for senior departmental representatives as described in A3.4 and A6.1. The maximum office size of 10 m² is applied consistently regardless of the levels of the positions.

Offices for ministerial exempt staff may be located on perimeter walls where no other option exists as a result of the high ratio of closed to open space. Standard mechanical requirements are as per those described under the typical office layout for associate deputy ministers in B4.1.

Support Space

Meeting Rooms

Ministerial and deputy head suites are allocated one medium-sized meeting room each, in addition to the meeting room allowances described in A3.4. Departmental boardrooms (classified as special purpose space) are also typically collocated with the deputy heads' suites.

Quiet/Touchdown Rooms

Quiet/touchdown rooms are provided in accordance with A3.4 where the number of employees located in open workstations within the ministerial or deputy ministerial suite is greater than 10.

Kitchenettes

Kitchenettes are provided in both ministerial and deputy head suites. The sample plan in B3.1 illustrates a typical configuration of these spaces sized to suit the population and functions they serve. The general administrative office space standards for kitchenettes, as described in A3.4, apply with the exception that millwork for ministerial and deputy head kitchenettes is modified to accommodate a dishwasher. See B4.2 for a drawing that illustrates the typical millwork provisions.

- Planning ratio:** one 10 – 20 m² kitchenette per suite
- Millwork:** 3,000 linear mm (10') of counter and upper/lower storage per kitchenette

Shared Equipment Areas

The general-purpose office space standards for shared equipment areas, as described in A3.4, apply with the exception that ministerial and deputy ministerial suites are allocated additional space to accommodate special equipment requirements and lockable doors to provide access control.

Planning ratio: one 10 – 14 m² area per suite

Millwork: 2,400 linear mm (8') of counter and lower storage per area

Reception Waiting Area

A reception area with seating and display is typically located adjacent to the departmental boardroom, or as otherwise required.

Note: In instances where there are multiple ministerial and/or deputy head suites on a floor, support spaces, in particular reception, meeting and kitchenette facilities, shall be shared to the greatest extent possible.

B3. Planning

B3.1 Planning and Design

Hard wall construction is significantly more extensive to provide the additional access control and speech privacy associated with ministerial and deputy head offices.

However, the planning and design principles described in A5.1 are still to be applied, to the greatest extent possible, to ensure those in open workstations have access to natural light.

The following sample floor plan illustrates these factors as applied to the allocations for ministerial and deputy head office and support space.

Planning Notes and Legend

General Information

Total usable space: 891 m² (9,590 ft²) minus 96 m² (SPS) = 795 m² (8,557 ft²)

Total FTEs: 24 (10 workstations, 14 closed offices)

Space per FTE: 33.13 m²/FTE (356.50 ft²/FTE)

Total open areas: 151 m² (1,625 ft²)

Total enclosed areas: 644 m² (6,932 ft²)

Open/closed ratio: 19%/81%

List of Support Spaces

3 medium meeting rooms (10-12 people), 2 dedicated and 1 shared (doubles as breakout room for boardroom)

1 reception/waiting area

2 shared equipment areas (copier/fax/printer)

2 kitchenette/lunch areas

1 closet

1 storage/file room (Undesignated Support Space)

List of Special Purpose Space

1 departmental boardroom with closets and display

Legend



Solid lines indicate standard fit-up

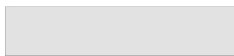

Hatch pattern indicates ministerial exempt staff



Hatch pattern indicates base building

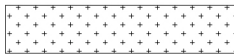

Hatch pattern indicates carpet inserts



Hatch pattern indicates resilient flooring

See B2.2 for planning ratios and other requirements.

B4. Sample Detail Drawings

B4.1 Offices

Typical Office Layout with Washroom – Minister (example 1)

office – maximum 48 m² (517 ft²)/washroom – maximum 9 m² (97 ft²)

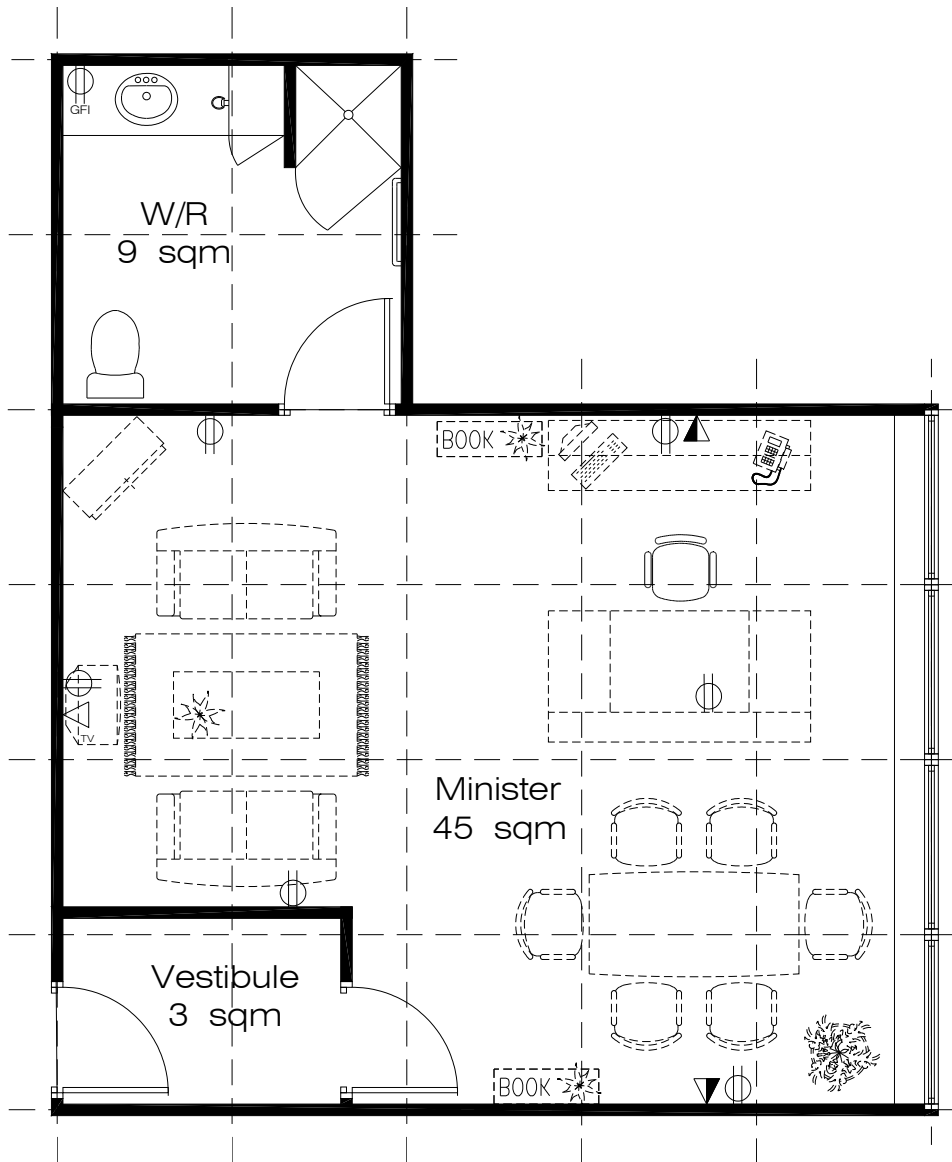

Summary

Office accommodates requirements for personal workspace, shelving, storage, soft seating and small meeting table. Furniture layouts may vary.

Standard Electrical Requirements

- 6 standard electrical duplex receptacles (2 circuits) plus GFI (ground fault interrupter) duplex receptacle in washroom
- 3 image/voice/data outlets
(**Note:** client to provide actual connectors and jacks, typically RJ45 with multiple jacks)
- separate switch/light controls as required

Standard Mechanical Requirements

Perimeter zone:

Note: HVAC system must be capable of operating on a "24/7" basis

- individual thermostat control c/w dedicated terminal units (VAV box, fan coil unit, air handling unit) and interlock to perimeter system
- supply and return air diffuser(s)/grille(s)
- transfer return air fan c/w on/off switch for full height partitions
- washroom exhaust c/w exhaust air grille
- water closet, sink and shower c/w sanitary, vent, hot and cold water and insulation
- hot water tank (minimum 20-25 gallons)
- noise abatement and security as required

Typical Office Layout with Washroom – Minister (example 1 – reflected ceiling)

office – maximum 48 m² (517 ft²)/washroom – maximum 9 m² (97 ft²)

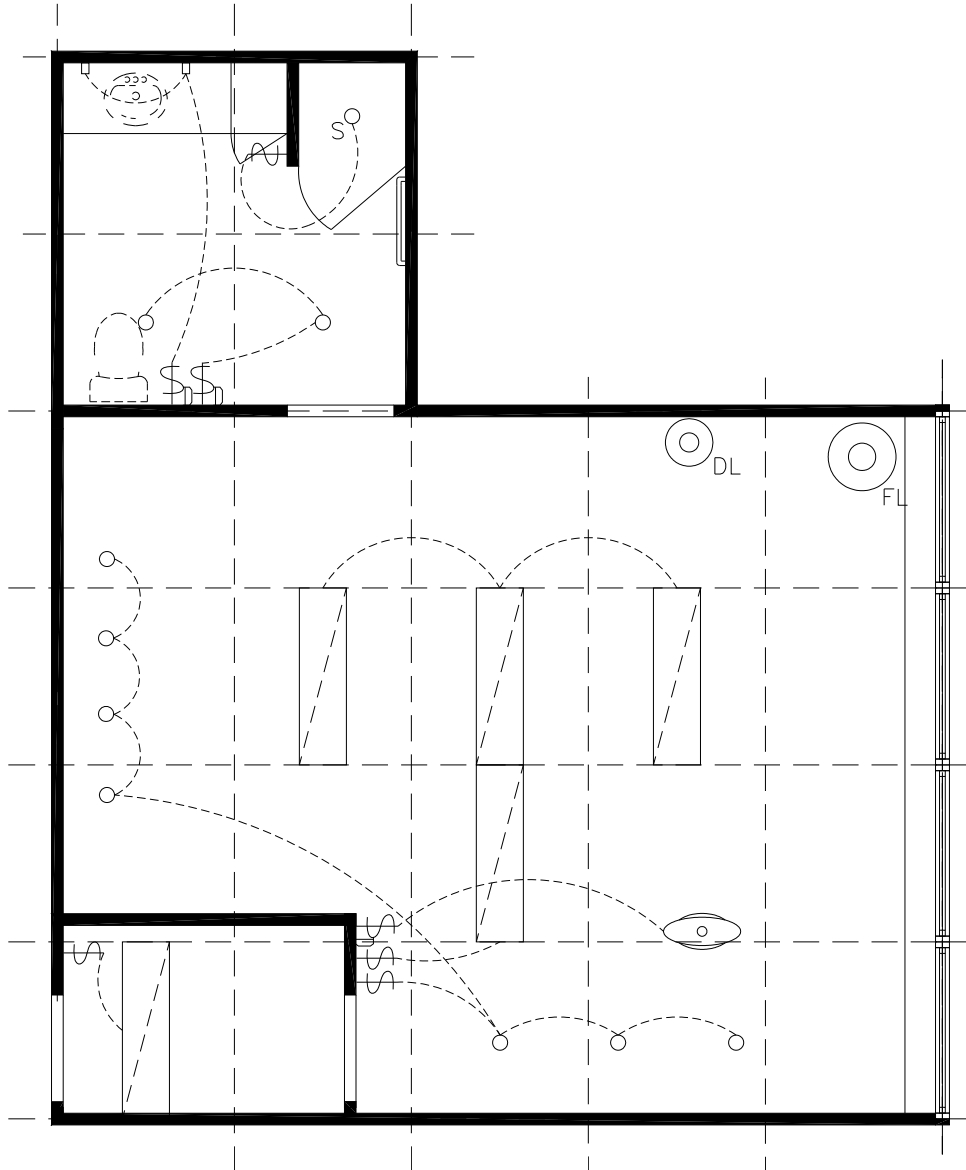

Legend

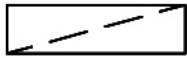

Fluorescent light



"Pot" light (RD)



Sealed shower light



Wall sconce



Light switch



Light switch with dimmer



Floor lamp



Desk lamp



Pendant light

Typical Office Layout with Washroom – Minister (example 2)

office – maximum 48 m² (517 ft²)/washroom – maximum 9 m² (97 ft²)

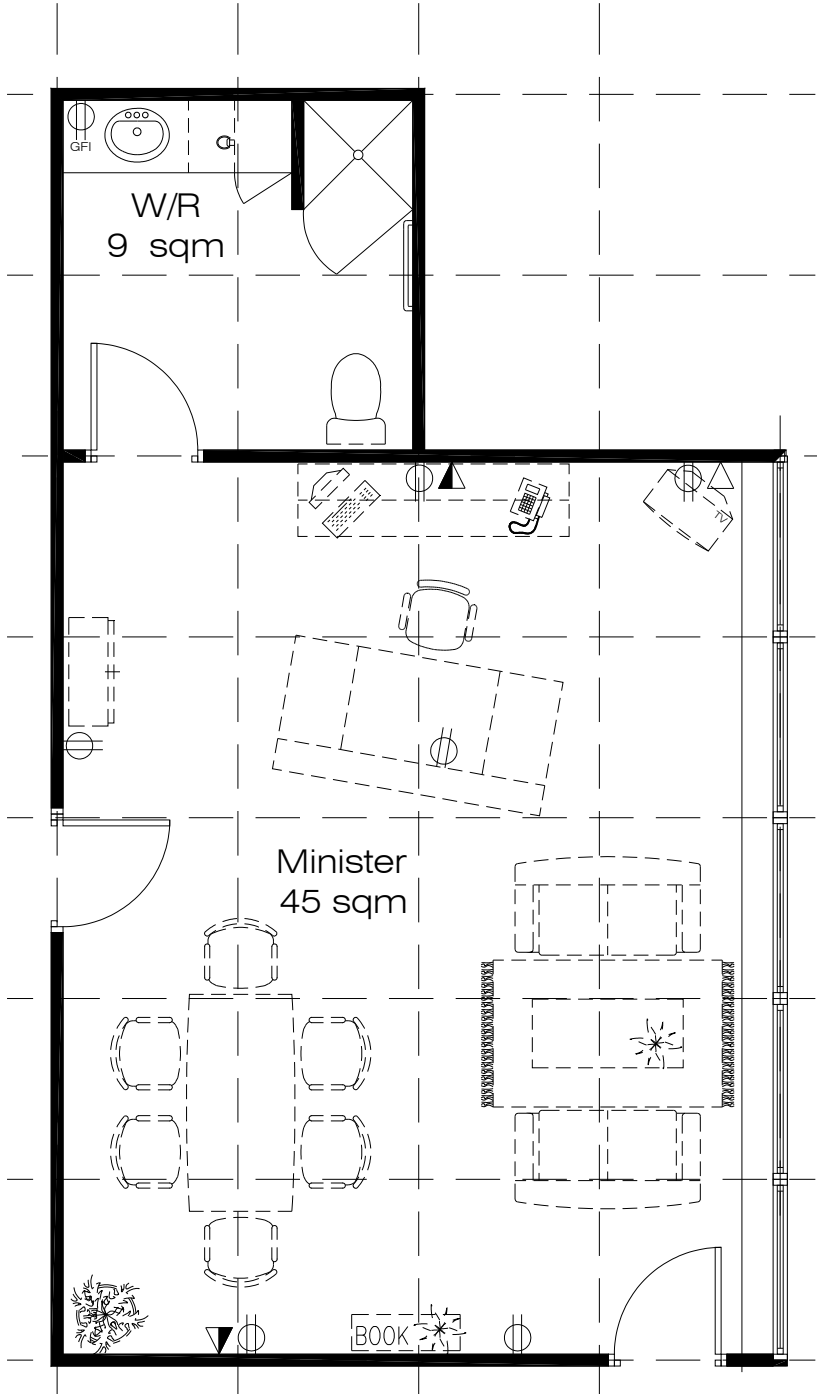

Summary

Office accommodates requirements for personal workspace, shelving, storage, soft seating and small meeting table. Furniture layouts may vary.

Standard Electrical Requirements

- 6 standard electrical duplex receptacles (2 circuits) plus GFI (ground fault interrupter) duplex receptacle in washroom
- 3 image/voice/data outlets
(**Note:** client to provide actual connectors and jacks, typically RJ45 with multiple jacks)
- separate switch/light controls as required

Standard Mechanical Requirements

Perimeter zone:

Note: HVAC system must be capable of operating on a "24/7" basis

- individual thermostat control c/w dedicated terminal units (VAV box, fan coil unit, air handling unit) and interlock to perimeter system
- supply and return air diffuser(s)/grille(s)
- transfer return air fan c/w on/off switch for full height partitions
- washroom exhaust c/w exhaust air grille
- water closet, sink and shower c/w sanitary, vent, hot and cold water and insulation
- hot water tank (minimum 20-25 gallons)
- noise abatement and security as required

Typical Office Layout with Washroom – Minister (example 2 – reflected ceiling)

office – maximum 48 m² (517 ft²)/washroom – maximum 9 m² (97 ft²)

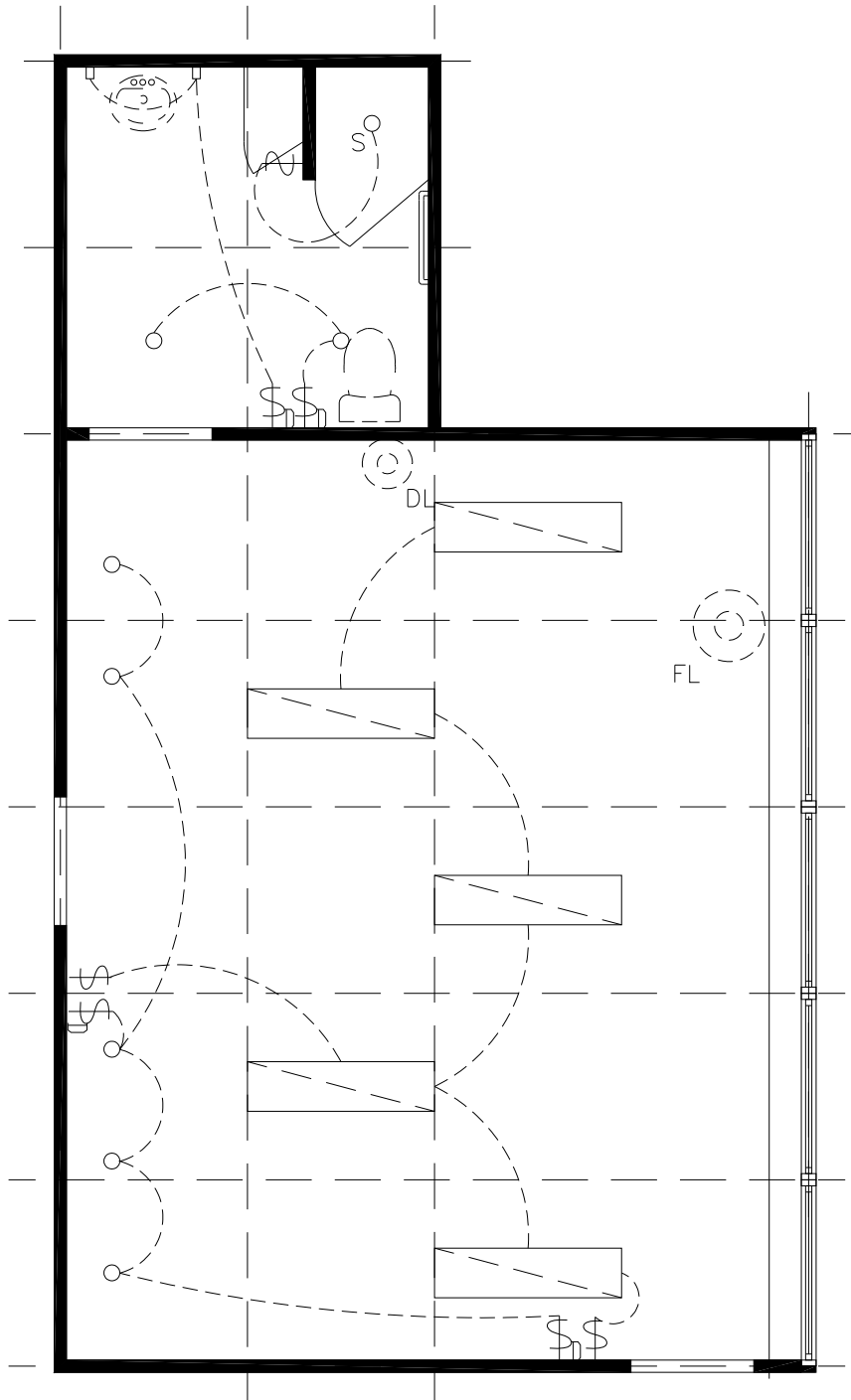

Legend

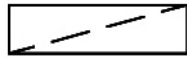

Fluorescent light



"Pot" light (RD)



Sealed shower light



Wall sconce



Light switch



Light switch with dimmer



Floor lamp



Desk lamp



Pendant Light

Typical Office Layout with Washroom – Deputy Minister

office – maximum 37 m² (398 ft²)/washroom – maximum 9 m² (97 ft²)

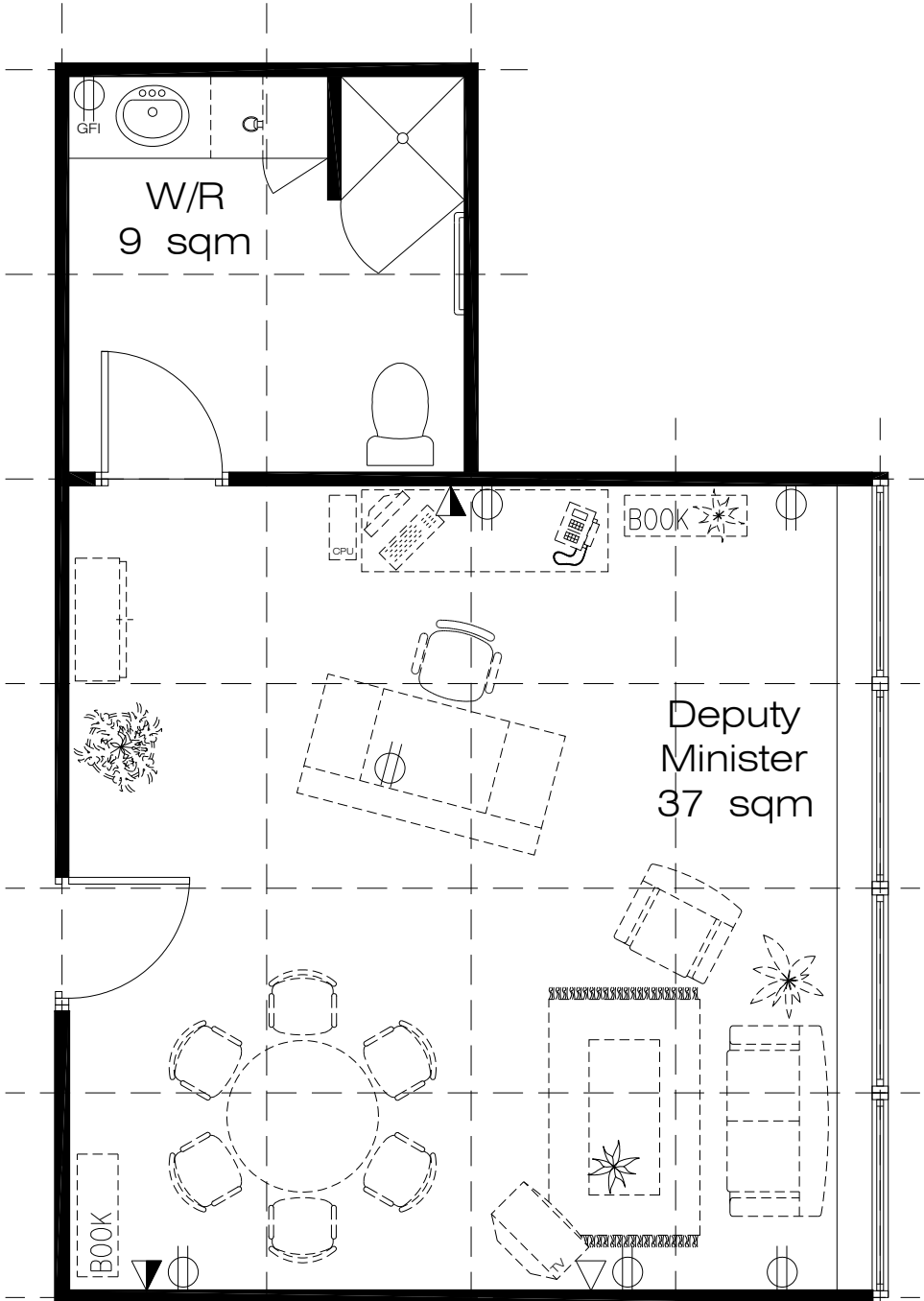

Summary

Office accommodates requirements for personal workspace, shelving, storage, soft seating and small meeting table. Furniture layouts may vary.

Standard Electrical Requirements

- 6 standard electrical duplex receptacles (2 circuits) plus GFI (ground fault interrupter) duplex receptacle in washroom
- 3 image/voice/data outlets
(**Note:** client to provide actual connectors and jacks, typically RJ45 with multiple jacks)
- separate switch/light controls as required

Standard Mechanical Requirements

Perimeter zone:

Note: HVAC system must be capable of operating on a "24/7" basis

- individual thermostat control c/w dedicated terminal units (VAV box, fan coil unit, air handling unit) and interlock to perimeter system
- supply and return air diffuser(s)/grille(s)
- transfer return air fan c/w on/off switch for full height partitions
- washroom exhaust c/w exhaust air grille
- water closet, sink and shower c/w sanitary, vent, hot and cold water and insulation
- hot water tank (minimum 20-25 gallons)
- noise abatement and security as required

Typical Office Layout with Washroom – Deputy Minister (reflected ceiling)

office – maximum 37 m² (398 ft²)/washroom - maximum 9 m² (97 ft²)

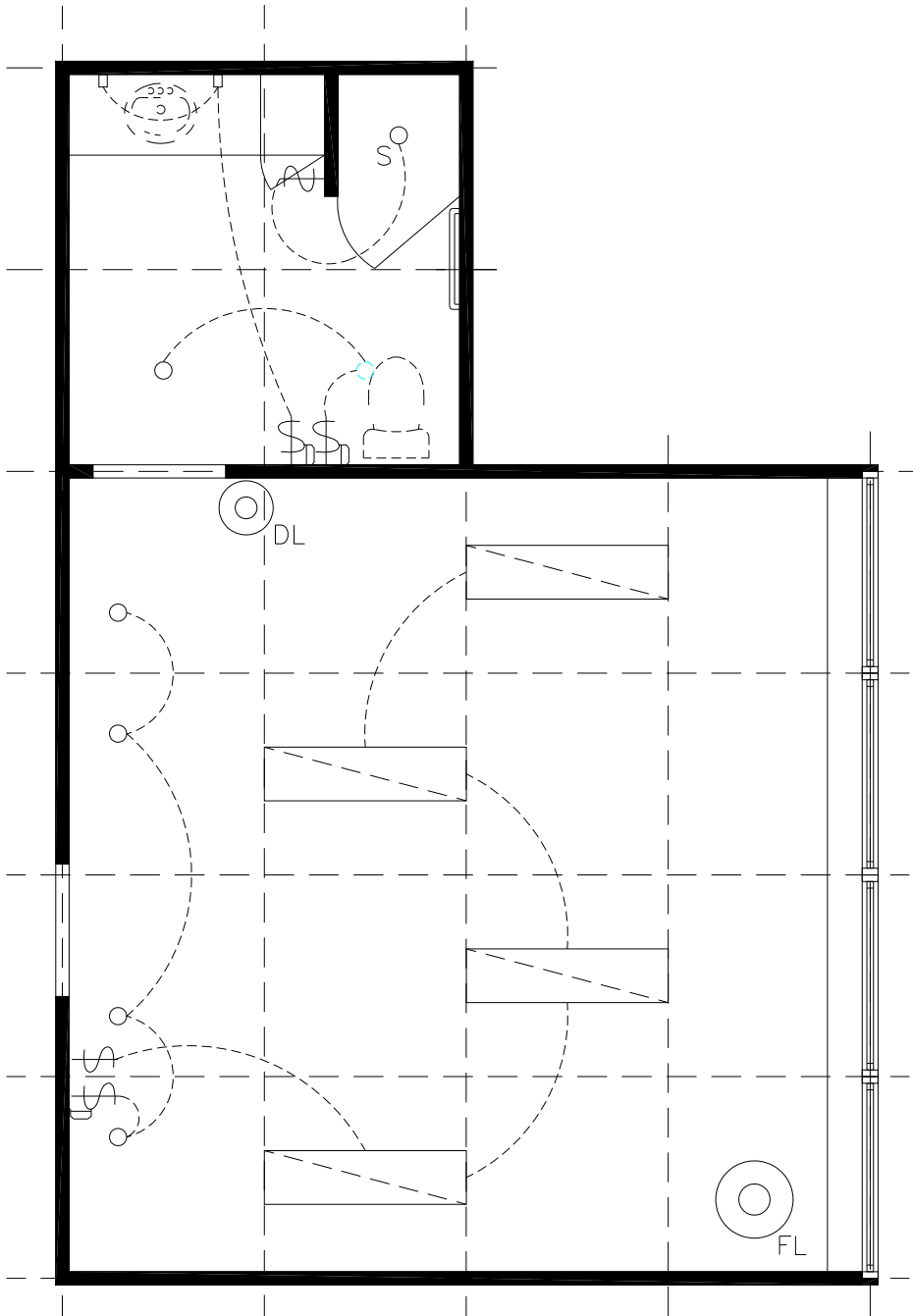

Legend

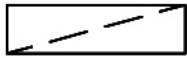

Fluorescent light



"Pot" light (RD)



Sealed shower light



Wall sconce



Light switch



Light switch with dimmer



Floor lamp



Desk lamp



Pendant Light

Typical Office Layout – Associate Deputy Minister

office – maximum 37 m² (398 ft²)

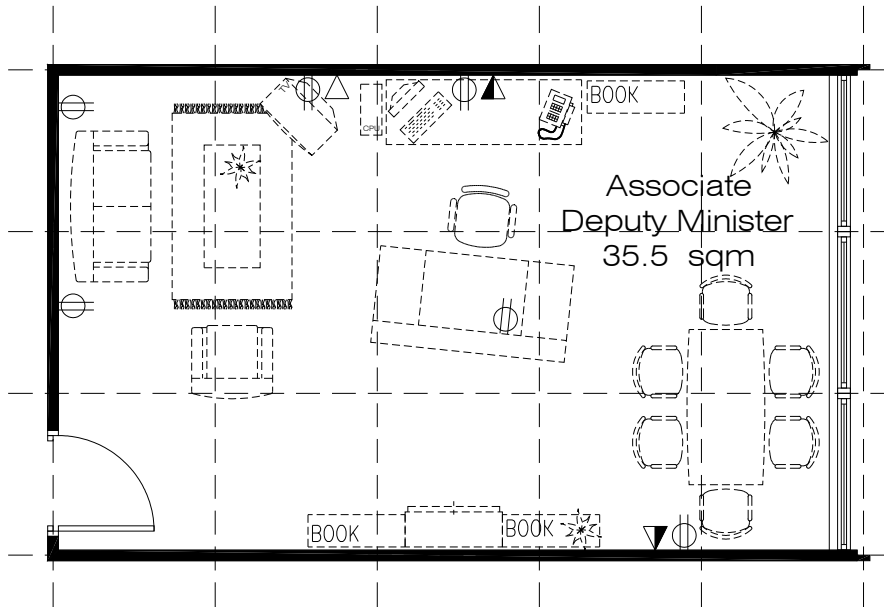

Summary

Office accommodates requirements for personal workspace, shelving, storage, soft seating and small meeting table. Furniture layouts may vary.

Standard Electrical Requirements

- 6 standard electrical duplex receptacles (2 circuits)
- 3 image/voice/data outlets
(**Note:** client to provide actual connectors and jacks, typically RJ45 with multiple jacks)
- separate switch/light controls as required

Standard Mechanical Requirements

Perimeter zone:

Note: HVAC system must be capable of operating on a "24/7" basis

- individual thermostat control c/w dedicated terminal units (VAV box, fan coil unit, air handling unit) and interlock to perimeter system
- supply and return air diffuser(s)/grille(s)
- transfer return air fan c/w on/off switch for full height partitions
- noise abatement and security as required

Typical Office Layout – Associate Deputy Minister (reflected ceiling)

office – maximum 37 m² (398 ft²)

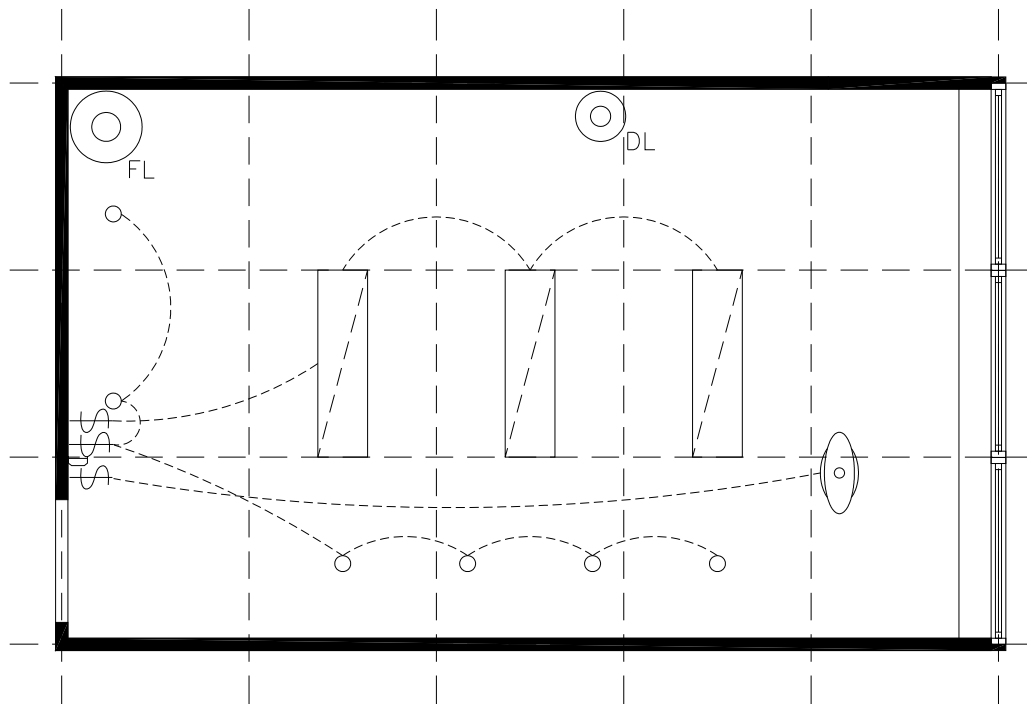

Legend

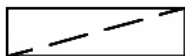

Fluorescent light



"Pot" light (RD)



Sealed shower light



Wall sconce



Light switch



Light switch with dimmer



Floor lamp



Desk lamp



Pendant Light

Typical Washroom Millwork (elevation) – Minister and Deputy Minister

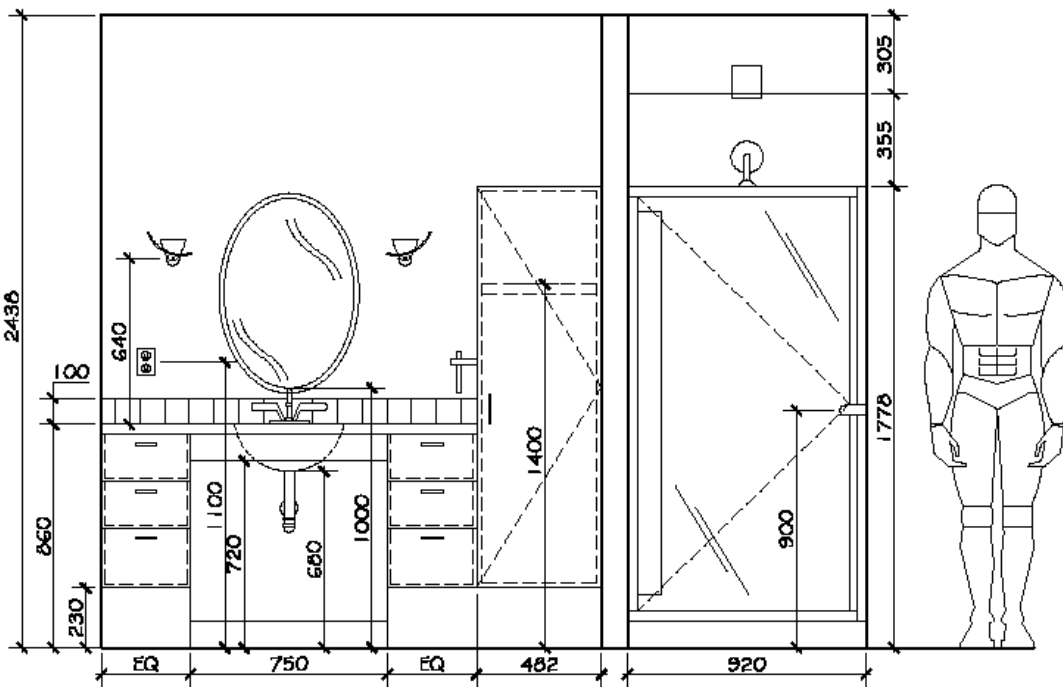

Summary

Area accommodates average requirements for washroom including built-in shower with standard glass shower door and frame assembly, hanging storage, vanity with basin and drawer storage, mirror and wall mounted lighting.

Backing to be provided in shower walls and around toilet to accommodate grab bars if required by future occupants.

Countertop and backsplash finishes to suit application and respect criteria outlined in A7.1. Mid-range quality fittings, hardware and accessories included as shown.

Standard Electrical Requirements

- 1 electrical duplex GFI (ground fault interrupter) receptacle

B4.2 Support Spaces

Typical Kitchenette Millwork (elevation) – Ministerial and Deputy Ministerial Suites

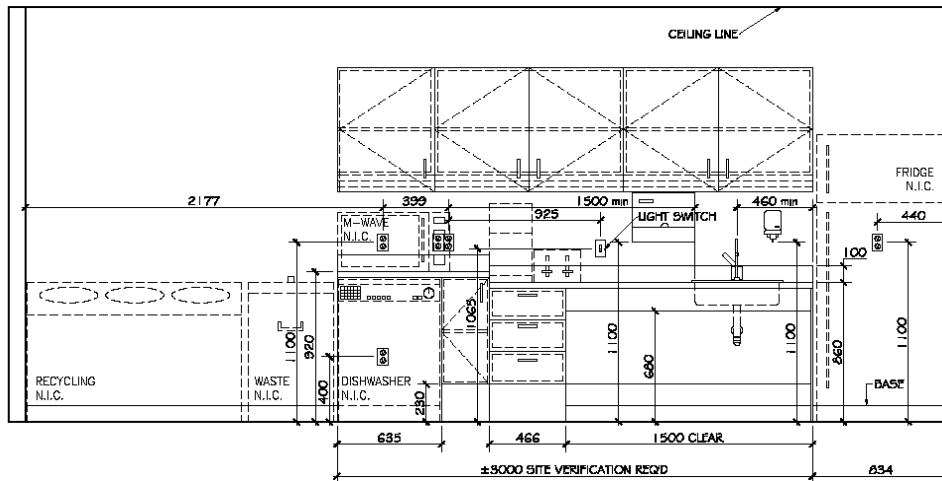

Summary

Area accommodates average storage requirements, recycling centre and trash as well as a full size fridge and countertop appliances (appliances not included). Design allows for barrier-free access to sink and counter. Paper towel and soap dispensers provided.

All finishes to suit application and respect criteria outlined in A7.1.

Standard Electrical Requirements

- 2 standard dedicated circuit duplex receptacles (microwave and fridge)
- 2 standard split circuit duplex receptacles for other countertop appliances
- 1 separate switch/light control for under cabinet lighting

Standard Mechanical Requirements

- hot water, cold water, drain and vent piping for kitchen sink
- kitchen exhaust fan c/w on/off switch (exhaust to exterior if economical and feasible)
- supply air diffuser(s) and grilles(s)
- no return air to base building system

B5. Costing

B5.1 Cost Estimates

Project managers and project officers are requested to follow the format shown in the example below when preparing their cost estimates for fit-up projects. This breakdown will help to determine those types of fit up elements that are more often associated with increased costs.

This costing example is based on the sample plan illustrated in B3.1. A blank version of this form is available in A9.1 Workplace 2.0 Fit-up Cost Estimate Template.

Generic Fit-up – Ministerial and Deputy Head Suite

Usable Floor Area: 795 m²

Cost Summary:

Fit-up Component	Total Cost Estimate	\$/m ²
Partitions	112,095	141
Doors and Frames (including hardware)	62,805	79
Finishes (wall covering and ceramic floor)	75,525	95
Millwork and Specialties (including shower and accessories)	72,345	91
Plumbing	65,190	82
HVAC (includes independent system and demolition of existing)	581,145	731
Fire Protection	18,285	23
Electrical	113,685	143
General Requirements ¹	165,360	208
Panels/screens (including service conduits, power receptacles and voice/data outlets)	38,160	48
Fit-up Total	1,304,595	1,641

¹ Includes insurance, bonding, site office and supplies, site safety and security and materials handling.

- Note:**
1. Estimate based on 2012-2013 cost data.
 2. Special purpose space not included in cost summary.

Variables that could impact on fit-up costs include, but are not limited to:

- project size;
- ceiling heights;
- specific detailing of partition assemblies;
- existing conditions (e.g. need to relocate a fire extinguisher or fire hose cabinet, a non-uniform layout of sprinklers or air supply/returns, etc.); and
- region/municipality.



Section C:

Quasi-judicial Office Space



C1. Introduction

C1.1 General Information

Overview

The following standards have been developed to address the special fit-up requirements of quasi-judicial office accommodation as provided by PWGSC in accordance with the *Framework for Office Accommodation and Accommodation Services*. The standards define a “bundle of goods” that may be provided within the existing space allocation standards for quasi-judicial functions.

They adopt the generic approach of the standards for general-purpose office space with some additional allowances. The most notable are the provision of: closed offices for Governor in Council (GIC) appointed members; a secure (public) reception area; additional hard walled support spaces; and dual circulation, as described under C2.2 and C3.1. These additional allowances provide quasi-judicial organizations with increased flexibility to customize their space to suit their particular program requirements.

In addition to the individual workspace and support space requirements of quasi-judicial offices, special purpose space (SPS) may be required. Although the very nature of SPS precludes any standardization, research indicates the following types are characteristic to quasi-judicial occupancies:

- hearing rooms, with or without translation, transcription/recording rooms;
- large centralized or regional case file rooms, where long periods of on-site retention are specifically required by law.

Refer to the *Guidelines for Special Purpose Space* for criteria used to determine SPS designations.

Effective Date

The effective date of the quasi-judicial office space fit-up standards is September 3, 2008.

C1.2 Application

These standards apply to quasi-judicial office space. Quasi-judicial office space is used by certain departments and agencies in support of a mandate to render decisions and actions that are legally binding, but not governed by judicial organizations, such as courts.

The functions of organizations that are quasi-judicial in nature may include investigation and review of practices, protocols and individuals (victims, offenders, witnesses, members of the public) related to quasi-judicial cases, hearings, enquires and/or complaints. These functions involve face-to-face contact with members of the public and are directly related to the mandates of the organizations as well as their capacity and legislative authority to deliver judgments or binding decisions.

These organizations may also have “Headquarters” or other operations that are general administrative in nature. Therefore, each location should be carefully assessed to first confirm the function and subsequently the appropriate category of space.

Key points of clarification when managing accommodation for quasi-judicial functions include:

- No single department is completely quasi-judicial in nature. Therefore, client departments are not universally categorized as being “quasi-judicial”, but rather as departments that require some quasi-judicial office space to execute their federal mandate;
- Quasi-judicial office space is not limited to particular buildings or regions, but rather to certain occupancies;
- Quasi-judicial office space is a type general-purpose office space, although, as previously noted, quasi-judicial offices may also have SPS requirements; and
- Quasi-judicial office space differs from judicial space in that judicial space is reserved for courts that render legally binding decisions with authority found in Canadian criminal and civil code (e.g. Tax Court of Canada, Federal Court, Supreme Court).

Organizations that require space for the purpose of quasi-judicial functions, may include, but are not limited to: boards, tribunals, bureaus, commissions and authorities. Some examples of PWGSC clients that use quasi-judicial office space include: Immigration and Refugee Board, Security Intelligence Review Committee, and the National Parole Board.

C2. Standards

C2.1 Fit-up Components and Funding Accountabilities

The following chart identifies fit-up components and funding accountabilities related to the special fit-up requirements for quasi-judicial office space. All standard fit-up components not included in this chart are provided and funded in accordance with the general-purpose office space standards as described in A3.3.

PWGSC is responsible for initial fit-up of the space based on the functional and operational requirements of the end user. Changes to existing offices during the term of the occupancy are funded by the department or agency as a tenant service.

Components		Base Building	Fit-up Standards	Other
A	Interior Construction			
	1. Partition Walls			
	(a) <i>Offices for GIC appointees</i>			Yes ²
	<ul style="list-style-type: none"> slab to underside of ceiling with insulation and plenum barriers (enhanced speech privacy). <p>Note: glazing treatments may be appropriate for increased light transfer and visual access but are not recommended when speech privacy is a priority.</p>			
	(b) <i>Support spaces</i>			Yes ²
	<ul style="list-style-type: none"> Public reception and waiting area – slab to underside of ceiling with insulation (standard speech privacy). 			Yes ²
	<ul style="list-style-type: none"> Interview, counsel, break-out, discovery and similar rooms, client waiting areas – slab to underside of ceiling with insulation and plenum barriers (enhanced speech privacy). 			Yes ²
	<ul style="list-style-type: none"> Employee washrooms (supported by a TRA based Security Design Brief) – slab to slab construction. 			Yes ²
	2. Doors and frames			
	(a) <i>Employee washrooms – doors provided with transfer grills.</i>			Yes ²
3. Door hardware				
(a) <i>Employee washrooms – cylinder with thumb turn lock.</i>			Yes ²	
4. Interior specialties				
(a) <i>Cabinetry and millwork</i>			Yes ²	
(i) Service counters in reception area.				
(ii) Counter in employee washroom.			Yes ²	
B	Services			
	1. Plumbing systems			
(a) <i>Employee washrooms – fixtures and accessories for two-piece washroom to match base building quality.</i>			Yes ²	

² Client cost – NOT subject to the non-compliance approval process.

C2.2 Office and Support Space Allocations

This section describes standard provisions for some typical quasi-judicial office and support space allocations.

These allocations are provided in addition to the standard office and support spaces identified under A3.4. Together, they must be managed within the space allocation standards for quasi-judicial office space. Office and support spaces beyond those that can be accommodated within the standard quasi-judicial office space allocation will be considered non-compliant and subject to the Approvals and Governance process outlined in A2.3 Process for Approval of Non-Compliance.

Office Space

Closed Offices for Governor in Council (GIC) Appointees

Closed offices are provided for GIC appointees in accordance with the office allocations for EX-1 and EX-2 positions as described in A3.4. The office size may range from 10 – 14 m² to suit the priorities and typical levels of members within each organization. However, one size is applied consistently within each organization to allow for long-term flexibility as appointments change. Offices are to be located on the interior where building conditions allow.

Part-time appointees must share offices, wherever possible – typically at a 3:1 or 2:1 ratio, as appropriate.

Support Space

In addition to the common support spaces outlined in A3.4, quasi-judicial operations typically require spaces to support their public-contact activities. It is expected that the type, quantity, size, configuration and placement of these spaces will vary with each occupancy and site condition.

The following are descriptions of some typical quasi-judicial support functions.

Reception and Waiting Areas

A secure reception area with seating is typically provided adjacent to the main entrance or elevator lobby as appropriate to provide the visibility and accessibility required by the particular operation.

These spaces are provided in support of hearing room functions. They are the main point of entry for claimants, appellants, their family, friends, counsel and others involved in the hearing process. They must accommodate a reception desk or counter, seating and coat storage as required by average client volumes and adequate circulation space. In some cases, a security officer may be accommodated within or adjacent to the reception area to oversee activities and traffic flow.

Multi-floor occupancies are typically served by one large reception area.

- Maximum area:** to suit (within space allocation standards)
- Floor finish:** resilient, ceramic tile or base building standard carpet to suit operational and site conditions
- Wall finish:** paint and/or wall covering or unfinished to suit substrate
- Lighting:** base building

Counsel Rooms/Interview Rooms

See C4.1 for a drawing that illustrates the typical size and configuration of a counsel/interview room. These rooms may also be referred to as mediation or deliberation rooms and are intended for the use of claimants or appellants and their counsel prior to the start of a hearing. One or more of these rooms may be provided for a variety of similar functions that typically involve a one-on-one or two-on-one exchange or gathering and recording of information.

- Maximum area:** 14 m²
- Floor finish:** base building standard carpet
- Wall finish:** paint or unfinished to suit substrate
- Lighting:** base building with separate switching

Work Rooms

These rooms are provided for a variety of related functions e.g. breakout rooms, alternative dispute resolution rooms, case preparation rooms, case review rooms, tactical rooms and appointees' rooms. They should be sized to suit the particular capacity required, and fit up as meeting rooms. See A3.4 for additional information.

Employee Washrooms

See C4.2 for drawings that illustrate the typical size and configuration for employee washrooms. A dedicated accessible two-piece washroom is provided where public access to base building washrooms present security concerns for the employees.

- Maximum area:** as required to meet CAN/CSA B651-04 *Accessible Design for the Built Environment*
- Floor finish:** ceramic tile
- Wall finish:** ceramic tile and paint or unfinished to suit substrate
- Lighting:** base building with separate switching

Waiting Rooms/Detention areas

These rooms may be required (based on a threat and risk assessment) to maintain control of detainees brought to attend a hearing. The detainees are held in these rooms for short periods of time prior to or following a hearing and during breaks. The size and type of detention area varies. It may consist of an individual holding room only or also require a security guard area and/or separate washroom.

Maximum area: to suit (within space allocation standards)

Floor finish: base building standard carpet

Wall finish: paint or unfinished to suit substrate

Lighting: base building with separate switching

C3. Planning

C3.1 Planning and Design

The planning and design principles described in A5.1 are to be applied, to the greatest extent possible, to quasi-judicial accommodation. Opportunities for collocation with similar organizations should be considered and encouraged, where appropriate.

Security Requirements

Security requirements are of particular importance in the context of quasi-judicial offices. They must be based on a threat and risk assessment, highlighted at the project definition phase, well defined during the project identification stage, and signed off by the departmental security officer. This will ensure the acquisition of appropriate space and the development of optimal layouts.

Dual circulation is a security based requirement common to many quasi-judicial offices. Additional entry points and corridors may be required for some quasi-judicial occupancies to separate public (e.g. hearing and mediation rooms) from private (employee) areas and, in some cases, to provide alternative passage for different client groups (e.g. victims and offenders, witnesses and accused). For similar reasons, some quasi-judicial hearing rooms require two means of entry/exit. The space allocation standards should, in most cases, accommodate dual circulation requirements.

The following sample floor plans illustrate these planning considerations as applied to the standard allocations for quasi-judicial office and support space.

C3.2 Sample Plans

C PL1 DIAGRAM

Planning Notes and Legend for C PL1

C3.2 Sample Plans are currently undergoing revisions to reflect changes made to Section A of the *Workplace 2.0 Fit-up Standards*.

C PL1 Diagram

C3.2 Sample Plans are currently undergoing revisions to reflect changes made to Section A of the *Workplace 2.0 Fit-up Standards*.

C PL2 DIAGRAM

Planning Notes and Legend for C PL2

C3.2 Sample Plans are currently undergoing revisions to reflect changes made to Section A of the *Workplace 2.0 Fit-up Standards*.

C PL2 Diagram

C3.2 Sample Plans are currently undergoing revisions to reflect changes made to Section A of the *Workplace 2.0 Fit-up Standards*.

C4. Sample Detail Drawings

C4.1 Support Space

Typical Counsel/Interview Room Layout

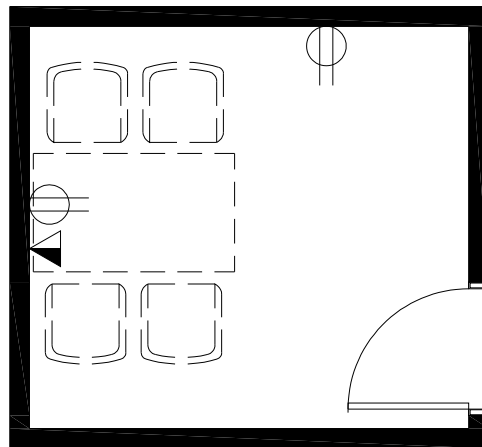

Summary

Space accommodates a small table and seating for 2 to 4. Configurations may vary.

Standard Electrical Requirements

- 2 standard electrical duplex receptacles
- 1 image/voice/data outlet
(**Note:** client to provide actual connectors and jacks, typically RJ45 with multiple jacks)
- separate switch/light controls as required

Standard Mechanical Requirements

- individual thermostat control c/w dedicated terminal units (VAV box, fan coil unit)
- supply and return air diffuser(s)/grille(s)
- transfer return air fan c/w on/off switch for full height partitions

Typical Employee Washroom

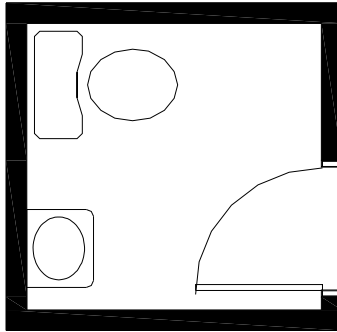

Summary

Area accommodates average requirements for a 2-piece washroom (basin and toilet). Accessories to include mirror, dispensers for paper towel, soap and toilet paper, and disposal receptacle(s). Grab bars to be provided as required to meet current accessibility standards. Fixtures, fittings and accessories are to match base building standard. Basin vanity or separate counter provided.

Standard Electrical Requirements

- no power provided

Standard Mechanical Requirements

- supply and return air diffuser(s)/grille(s)
- transfer return air fan c/w on/off switch for full height partitions
- exhaust c/w exhaust air grille
- water closet and basin c/w sanitary, vent, hot and cold water and insulation
- noise abatement as required
- transfer return air fan c/w on/off switch for full height partitions

C5. Costing

C5.1 Cost Estimates

Project managers and project officers are requested to follow the format shown in the example below when preparing their cost estimates for fit-up projects. This breakdown will help to determine those types of fit up elements that are more often associated with increased costs.

This costing example is based on Plan Example C PL1 illustrated in C3.1. A blank version of this form is available in A9.1 Workplace 2.0 Fit-up Cost Estimate Template.

Sample Quasi-judicial Office Fit-up

Cost Summary: (Usable Floor Area: 1,119 m²)

Fit-up Component	Total Cost Estimate	\$/m ²
Partitions	156,660	140
Doors and Frames (including hardware)	68,259	61
Finishes	67,140	60
Millwork and Specialties	39,165	35
Plumbing	33,570	30
HVAC	119,733	107
Fire Protection	41,403	37
Electrical (including lighting modifications)	118,614	106
General Requirements ¹	96,234	86
Panels/screens (including service conduits, power receptacles and voice/data outlets)	201,420	180
Fit-up Total	942,198	842

¹ Includes insurance, bonding, site office and supplies, site safety and security and materials handling.

Note:

1. Estimate based on 2012-2013 cost data.
2. Special purpose space not included in cost summary.

Variables that could impact on fit-up costs include but are not limited to:

- project size;
- ceiling heights;
- specific detailing of partition assemblies;
- specific design features;
- existing conditions (e.g. need to relocate a fire extinguisher or fire hose cabinet, a non-uniform layout of sprinklers or air supply/returns, etc.); and
- quasi-judicial support spaces.



Section D:

Call/Contact Centres



D1. Introduction

D1.1 General Information

Overview

The following standards have been developed to address the special fit-up requirements of call/contact centre accommodation as provided by PWGSC in accordance with the *Framework for Office Accommodation and Accommodation Services*. They define the quantity and quality (the “bundle of goods”) of fit-up components that may be provided within the existing space allocation standards for general administrative office space functions.

The standards adopt the generic approach of the standards for general-purpose office space in Section A with some additional allowances to meet the special operational requirements of call/contact centres. The most notable are the provision of additional hard walled support spaces, and the provision of lunchroom/lounges/kitchenettes with lounge space, doors, the allowance for high-density acoustic ceiling tiles, direct and indirect lighting and the allowance for the partial use of glazed furniture panels.

These allowances are described in D2.2 Office and Support Space Allocations and D3.1 Planning and Design and provide increased flexibility to customize call/contact centre space to suit particular program requirements.

Effective Date

The effective date of the call/contact centre office space fit-up standards is April **2012**.

D1.2 Application

These standards apply to federal call/contact centre office space. Call/contact centre office space is used by certain departments and agencies in support of a mandate to respond to a high volume of enquiries regarding their programs and services.

The functions of organizations that are call/contact centres include: responding to the public and public servants about specific government initiatives or ongoing programs and services; and processing requests for services or information. These functions primarily involve telephone contact with members of the public and employees and services may also be provided until late in the evening and on weekends. Training is ongoing due to a high turnover of staff and the requirement to update staff about new programs and program changes.

Key points of clarification when managing accommodation for call/contact centres include:

- Most departments and agencies have some type of public contact function. Call/contact centres refer to specific organizations within departments whose mandate is to respond to a high volume of calls on programs and services. Therefore, client departments are not universally categorized as being “call/contact centres”, but rather as departments that require some call/contact centre office space to execute their federal mandate.
- Call/contact centre office space is not limited to particular buildings or regions, but rather to certain occupancies.
- Call/contact centres are also characterized by the high degree of specialized technology required to operate their activities.
- Call/contact centre office space is a type of general-purpose office space, although, call/contact centre offices may also have unique space requirements.

Some examples of organizations that use call/contact centre space include but are not limited to: Human Resources and Skills Development Canada, Elections Canada, Citizenship and Immigration Canada, Statistics Canada and Canada Revenue Agency.

D2. Standards

D2.1 Fit-up Components and Funding Accountabilities

The following chart identifies fit-up components and funding accountabilities related to the special fit-up requirements for call/contact centre office space. All standard fit-up components not included in this chart are provided and funded in accordance with the general-purpose office space standards as described in A3.3 Fit-up Components and Funding Accountabilities. PWGSC is responsible for initial fit-up of the space based on the functional and operational requirements of the end user. Changes to existing offices during the term of the occupancy are funded by the department or agency as a tenant service.

Components		Base Building	Fit-up Standards	Other
A	Interior Construction			
	1. Partition Walls			
	Public Reception and Waiting Area slab to underside of ceiling with insulation (standard speech privacy).			Yes ²
	Coaching/Interview rooms-slab to underside of ceiling with insulation (enhanced speech privacy).			Yes ²
D	Interior Construction			
	2. Doors and frames			
	(a) <i>Kitchenettes</i>		Yes	
	(i) Flush, solid core wood door, standard height and width (6'-8" or 7'-0" x 3'-0" wood veneer or paint finish w. door sweep).			
	5. Interior Finishes			
	(b) <i>Office and Support Areas</i>			Yes ²
	(i) Ceiling Finishes			
	• High density acoustic tile.			
	(ii) Floor Finishes			Yes ²
	• Raised floor systems and ramps, epoxy or other special treatments to suit client requirements.			
F	Furnishings and Equipment			
	(b) <i>Furniture and Equipment</i>		Yes	
	(i) Panels/screens complete with service poles (midrange quality component system, non-acoustic class with power/data capability). See A3.5.			
	(i) Panels/screens with partial glazing. See D2.3.		Yes	
E	Services			
	1. Plumbing Systems			
	(g) <i>Dishwasher, energy efficient, commercial style</i>			Yes ²
	5. Electrical Systems			
	(b) <i>Lighting</i>			Yes ²
	(ii) Modifications to base building fixtures to include direct and indirect lighting fixtures.			
	Sound masking		Yes	

² Client cost – NOT subject to the non-compliance approval process. Security requirements must be based on a Threat and Risk Assessment (TRA), Security Design Brief or Security Site Brief, signed off by the Departmental Security Office (DSO) and properly documented on the project file.

D2.2 Office and Support Space Allocations

This section describes standard provisions for typical call/contact centre office and support space allocations. These allocations must be managed within the space allocation standards for general-purpose office space as described in A3.4 Office and Support Space Allocations. Office and support spaces beyond those that can be accommodated within the standard call/contact centre office space allocation will be considered non-compliant and subject to the Approvals and Governance Process outlined in A2.3.

Office Space

Open Workstations

A single floor, open plan, is the preferred type of office space for call/contact centres. Open workstations, adaptable to team or individual configurations, are assigned to all personnel in open plan call/contact centre environments. Workstation sizes vary according to specific site conditions and functional requirements of the space. As call/contact centres require a high number of employees to carry out their functions, smaller workstations are typical. Call/contact centre employees are typically required to be at their workstations for 90% of the day, and equipment may include two monitors. Workstation sizes will vary to suit the needs of the organization but will not exceed 3.7 m² for agents. Workstations for supervisors, quality assurance, information technology, phone traffic control and administrative staff will not exceed 5.9 m². Part time/shift workers are to share workstations where possible. Possible workstation configurations are outlined in D4.1.

Support Space

Call/contact centres require common support spaces outlined in A3.4, however the allocation of support space differs due to the higher number of employees and type of work. Call/contact centres typically require spaces to support extensive training activities and provide adequate kitchen, eating and lounge areas for staff working on various shifts with short meal periods. As workstations may be shared, and storage within workstations is limited, locker rooms are required. Due to the high number of employees per supervisor and the high level of turnover of staff, coaching rooms are required to provide feedback to employees and staffing reception areas are required to support recruitment. The type, quantity, size, configuration and placement of these spaces will vary with each occupancy and site condition.

The following allocations are provided for call/contact centre support space:

Meeting Rooms

Meeting rooms provide enclosed spaces for meetings, presentations, collaborative work and recruitment drives. Retractable walls between training and meeting rooms are recommended to

provide additional flexibility. The following table summarizes provisions for meeting rooms for various population ranges.

FTEs per call/contact centre	Size of Meeting Room			Total
	Small 30 m ² seats 12	Medium 50 m ² seats 18	Large 60 m ² seats 20+	
25 – 50		1		1
51 – 75	2			2
76 – 100	2	1		3
101 – 125	1	2		3
126 – 150	1	1	1	3
151 – 175		2	1	3
176 – 200		1	2	3

Maximum area: to suit requirements (within space allocation standards)

Floor finish: base building standard carpet

Wall finish: paint and/or unfinished to suit substrate

Lighting: base building

Training Rooms

Due to turnover of staff and frequent changes in programs and services, training is an on-going requirement for call/contact centres. As some call/contact centres experience seasonal fluctuations, areas that can be quickly converted from training rooms to workstations are desired. Retractable walls between training and meeting rooms are recommended to provide additional flexibility. Freestanding, mobile furnishings are recommended. Raised flooring may facilitate conversion of training rooms.

Allocations for Training Rooms

FTEs per call/contact centre	Number of Training Rooms	Size of Training Room
25 – 50	1	30 m ²
51 – 125	1	40 m ²
126 – 225	2	68.8 m ²
Over 225	2	85 m ²

Maximum area: to suit requirements (within space allocation standards)

Floor finish: base building standard carpet

Wall finish: paint and/or unfinished to suit substrate

Lighting: base building

A sample layout of a call/contact centre training room is included in D4.2.

Coaching/Interview Rooms

Most call/contact centre supervisors are responsible for 10-15 agents and each agent is assessed several times per month. Coaching/interview rooms provide space for one-on-one coaching and to address particular employee needs. Coaching rooms may also be used to conduct interviews with potential staff. Allocations for interview rooms are as follows:

FTEs per call/contact centre	Number of 10.0 m ² spaces
25 – 50	1
51 – 75	2
76 – 100	3
101 – 150	4
151 – 200	5

Maximum area: 10.0 m²

Space accommodates typical office desking, storage and seating for four people. Data lines are required to facilitate coaching on systems. Configurations may vary. Space must meet CAN/CSA B651-04 *Accessible Design for the Built Environment*

Floor finish: base building standard carpet

Wall finish: paint or unfinished to suit substrate

Lighting: base building with separate switching

A typical layout of a coaching/interview room is included in D4.2.

Lunchroom/Lounge/Kitchenette

Due to the number of staff, extended hours and short lunch periods, lunchroom facilities must be adequate to accommodate both food preparation, vending machines, and an eating area. Counter space must be sufficient to accommodate multiple microwaves, coffee makers and other equipment. Lounge space may be provided to allow for collaborative spaces for employees to relax and socialize, as personal interaction is typically not permitted in the call/contact centre service areas. Lunchroom areas may be combined to create larger areas depending on site conditions.

FTEs per call/contact centre	# and size of areas	Lin. mm of counter and upper/lower storage in each area
25 – 50	one 40 – 60 m ²	4,800 (16')
51 – 75	two 40 – 60 m ²	4,800 (16')
76 – 100	two 40 – 60 m ²	4,800 (16')
101 – 150	two 40 – 60 m ²	4,800 (16')
151 – 200	three 40 – 60 m ²	4,800 (16')

See D4.2 for a drawing that illustrates the typical provisions for a lunchroom/lounge/kitchenette including descriptions of standard finishes and mechanical and electrical provisions.

Entrance doors are permitted on call/contact centre kitchenettes in order to reduce noise transfer to the call/contact centre work area.

Locker Areas

Due to the large number of staff, size of workstation and the fact that workstations may be shared, locker areas for storage of personal items are required.

Allocation of locker rooms is as follows:

FTEs per call/contact centre	Number of 14 m ² spaces
25 – 50	1
51 – 125	2
126 – 200	3

See D4.2 for a typical locker area layout including descriptions of standard finishes and mechanical and electrical provisions. Locker areas would ideally be located near the entrance and kitchen areas.

Shared Equipment Areas

Shared equipment areas may be open or semi-enclosed but entrance doors are not provided. The following summarizes provisions for shared equipment areas for various population ranges:

FTEs per call/contact centre	# and size of areas	Lin. mm of counter and upper/lower storage in each area
25 – 50	one 10 – 14 m ²	2,400 (8')
51 – 100	two 10 – 14 m ²	2,400 (8')
101 – 150	three 10 – 14 m ²	2,400 (8')
151 – 200	four 10 – 14 m ²	2,400 (8')

See A6.2 Support Spaces for a drawing that illustrates the typical provisions for a shared equipment area including descriptions of standard finishes and mechanical and electrical provisions.

Quiet Rooms

These are spaces intended for the shared use of personnel who normally occupy open workstations. They provide an enhanced acoustical environment for a private telephone call, to support work requiring a high level of concentration, or similar functions. The following table summarizes provisions for quiet rooms for various population ranges:

FTEs per call/contact centre	# of 5 m ² spaces
25 – 50	1
51 – 100	2
101 – 150	3
151 – 175	4
176 – 200	5

See A6.2 Support Spaces for a drawing that illustrates the typical provisions for quiet rooms including descriptions of standard finishes and mechanical and electrical provisions.

Reception and Waiting Areas

A reception area with seating is typically provided adjacent to the main entrance or elevator lobby.

These spaces are provided for the public attending recruitment drives or interviews. These spaces accommodate, seating and coat storage as required by average volumes and adequate circulation space.

Multi-floor occupancies are typically served by one large reception area.

Maximum area: to suit (within overall space allocation standards)

Floor finish: resilient, ceramic tile or base building standard carpet to suit operational and site conditions

Wall finish: paint or unfinished to suit substrate

Lighting: base building

Other Support Spaces

Call/contact centres may also have requirements for specialized telecommunications equipment. Dedicated equipment or telecommunications rooms will be provided to suit as required (within overall space allocation limits), and will be designed according to the technical standards outlined in A4.

D2.3 Standards for Furniture Panels/Screens

Panels are used to provide visual privacy in open-plan office environments. Panel height, classification and finish are described in A3.5 Standards for Furniture Panels/Screens. The nature of call/contact centre work requires that there be visual contact between team members and with team leaders and managers. At the same time, there is a need to maintain as much acoustic privacy as possible.

For call/contact centres glazed panels with a maximum height of 38 cm (15") are allowed as required for visual contact within the call/contact centre as long as the overall maximum height is not exceeded. Fully glazed panels and sliding panels do **not** comply with the standards.

Clients may also purchase accessory items such as mobile whiteboards or add-on translucent or mesh dividers/toppers to create visual privacy with lower screen heights (maximum screen height cannot be exceeded).

A sample layout of call/contact centre workstations is found in D4.1 Typical Workstation Configurations.

Freestanding furniture with height adjustable work surfaces is recommended. The ergonomic features of chairs and keyboard trays must be carefully assessed when selecting furniture.

D3. Planning

D3.1 Planning and Design

The planning and design principles described in A5.1 are to be applied, to the greatest extent possible, to call/contact centre accommodation. These principles provide the flexibility to meet the requirements of an organization.

Workstation Layout

A positive work environment is required to attract and retain employees to call/contact centre positions. As call/contact centre agents are required to be at their workstations for the majority of the day, access to natural light and exterior views, as well as visual contact with colleagues and supervisors is critical. Workstations with lower screens and some glazing are preferred. Ergonomic, height adjustable work surfaces and ergonomic chairs and keyboards are recommended. Acoustic control can be improved by arranging agent and supervisor workstations so cross transference of noise is minimized, and by including a sound masking system. Agent workstations should have easy access to water fountains and washrooms to minimize time away from the workstation.

Supervisor workstations should be within visual contact of call/contact centre agents. Supervisors should have easy access to interview rooms to provide feedback and private instruction to agents.

Meeting and Training Rooms

Freestanding, mobile furnishings are preferable for meeting and training rooms to provide for maximum flexibility. Meeting and training rooms should be designed to have the flexibility to use as agent stations during peak periods.

Retractable partitions may be considered for use within meeting and training rooms.

Locker Rooms and Shared Equipment Areas

Staff locker rooms should be located in open areas, ideally close to the entry and the kitchenette. Shared equipment areas should be located as far from agent workstations as possible.

The following sample floor plan illustrates these planning considerations as applied to the standard allocations for call/contact centre office and support space.

D3.2 Sample Plan

PL1 DIAGRAM

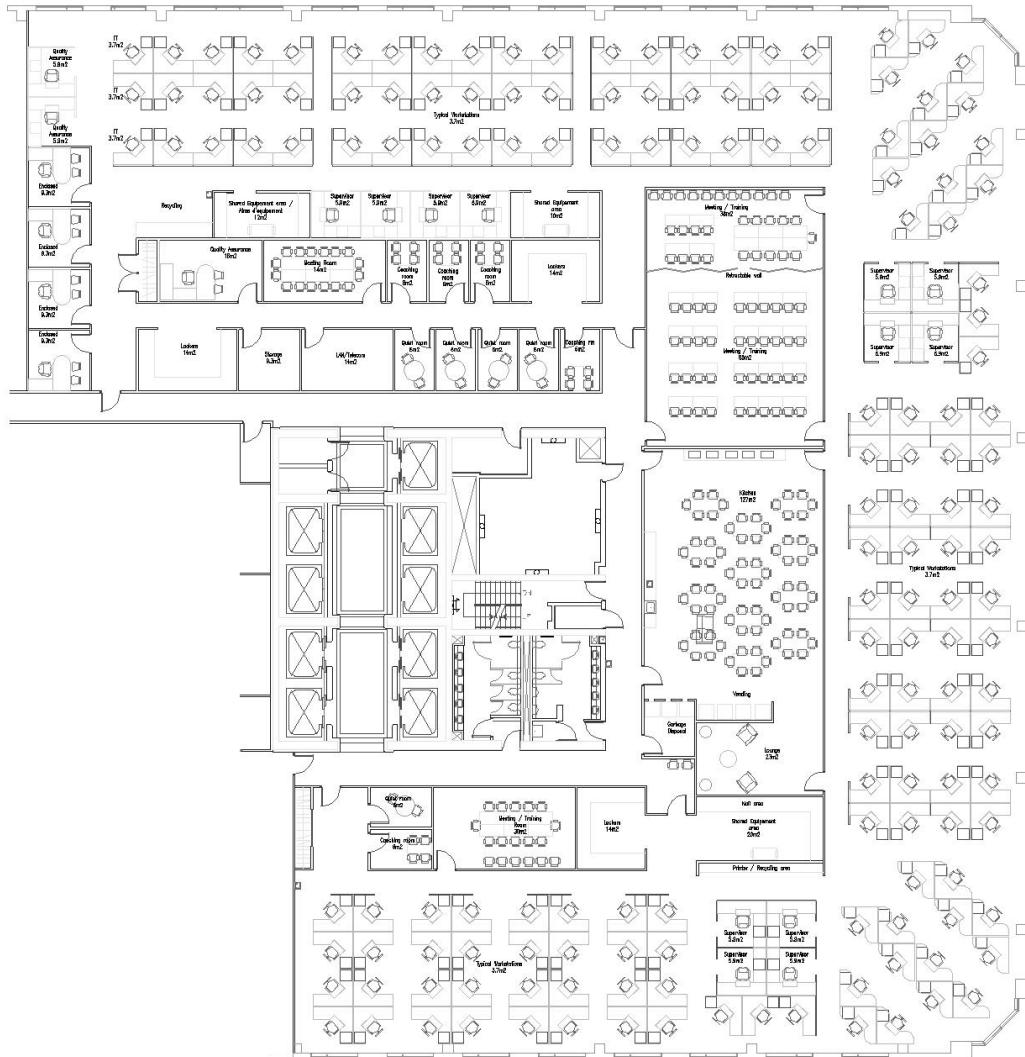

Planning Notes and Legend for PL1 Diagram

General Information

Total usable space: 1,829 m² (19,687 ft²)

Total FTEs: 175 (170 workstations, 5 closed offices)

Space per FTE: 11 m²/FTE (118.40 ft²/FTE)

Total open areas: 1,380 m² (14,854 ft²)

Total enclosed areas: 449 m² (4,833 ft²)

Open/closed ratio: 75%/25%

List of Support Spaces

3 meeting rooms

3 shared equipment/mail area

5 quiet rooms

1 kitchenette with lounge

1 printer/fax/file areas

List of Contact centre Support Spaces

5 coaching rooms

1 reception area

3 locker area

3 training rooms

D4. Sample Detail Drawings

D4.1 Typical Workstation Configurations

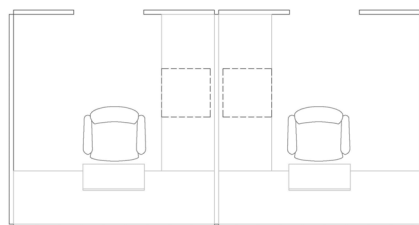
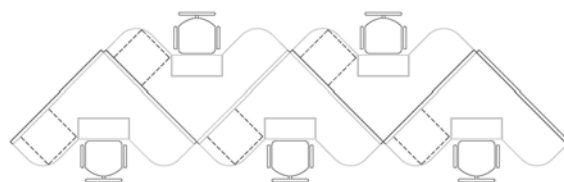
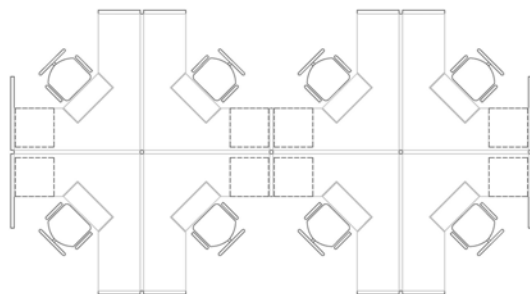

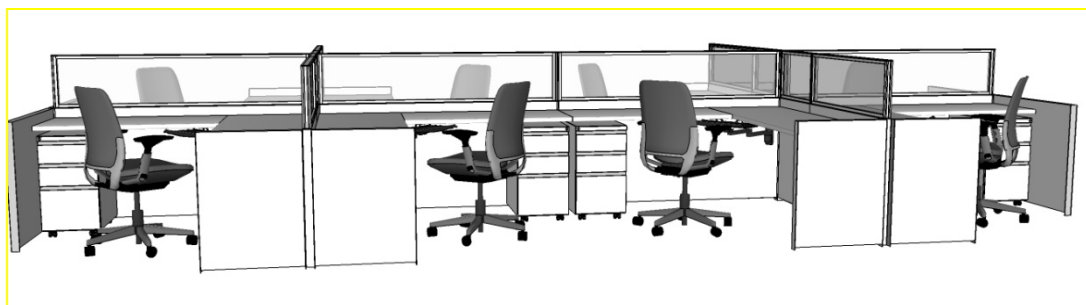

D4.2 Support Space

Typical Training Room

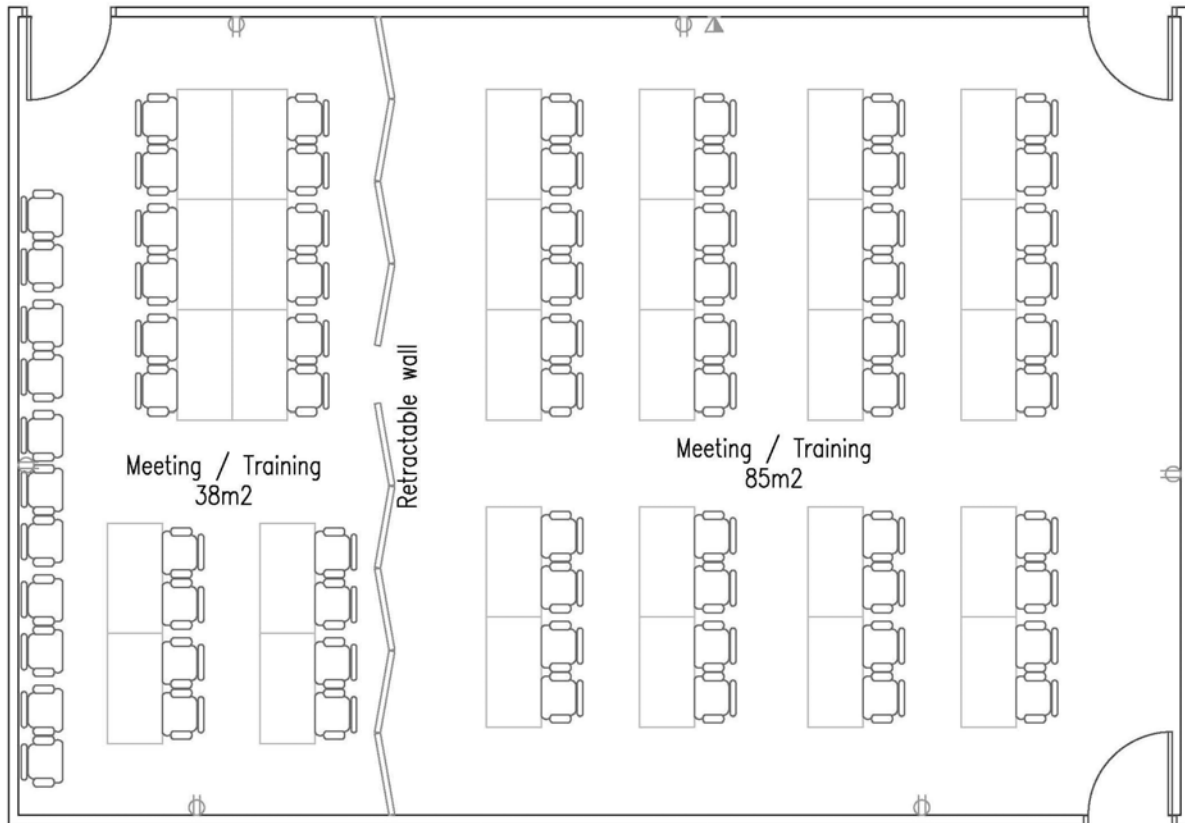

Summary

Space accommodates typical training tables and seating. Configurations may vary.

Standard Finishes

- Floor – base building carpet
- Walls – paint or unfinished to suit substrate

Standard Electrical Requirements

- standard electrical duplex receptacles to suit equipment needs
- image/voice/data outlet to suit equipment needs
(**Note:** client to provide actual connectors and jacks, typically RJ45 with multiple jacks)
- separate switch/light controls as required

Typical Coaching/Interview Room Layout

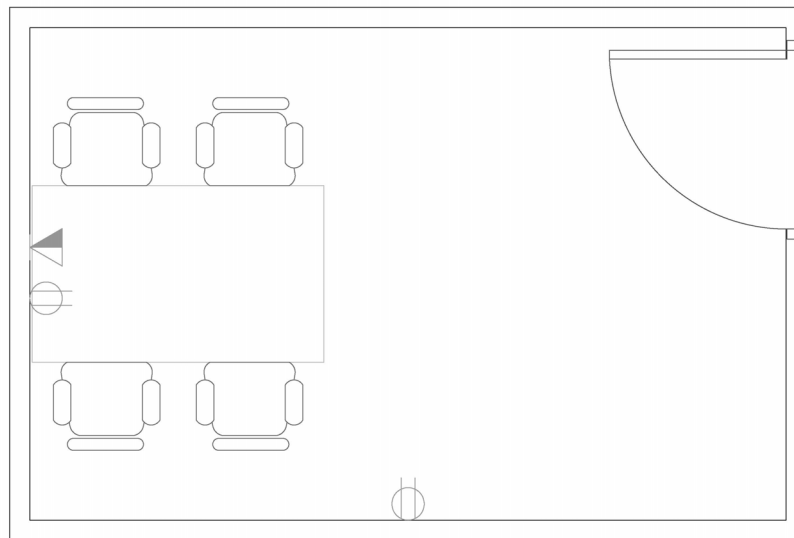

Summary

Space accommodates a small table and seating for 2 to 4. Configurations may vary.

Standard Finishes

- Floor – base building carpet
- Walls – paint or unfinished to suit substrate

Standard Electrical Requirements

- 2 standard electrical duplex receptacles
- 1 image/voice/data outlet
(**Note:** client to provide actual connectors and jacks, typically RJ45 with multiple jacks)
- separate switch/light controls as required

Standard Mechanical Requirements

- Individual thermostat control c/w dedicated terminal units (VAV box, fan coil unit)
- Supply and return air diffuser(s)/grille(s)
- Transfer return air fan c/w on/off switch for full height partitions

Typical Lunchroom/Lounge/Kitchenette

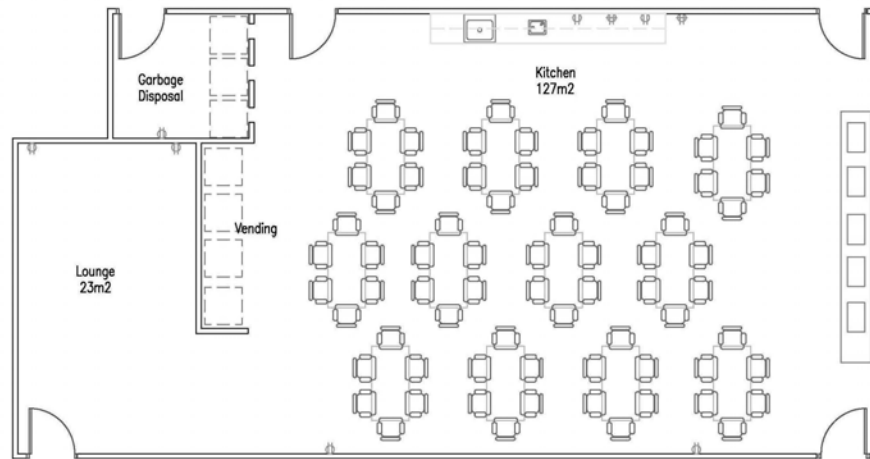

Summary

Area accommodates tables, seating, average storage requirements, recycling centre and trash as well as full size fridge(s) and countertop appliances (appliances not included). Design allows for barrier-free access to sink. Millwork for upper and lower cabinets is provided.

Standard Finishes

- Floor – resilient sheet or tile
- Walls – paint or unfinished to suit substrate
- Millwork – See A7.1 Finishes

Standard Electrical Requirements

- 2 standard dedicated circuit duplex receptacles (microwave and fridge)
- 2 standard split circuit duplex receptacles for other countertop appliances (additional receptacle may be provided if required)
- Base building lighting with motion sensor
- 1 separate switch/light control for under cabinet lighting
- 1 receptacle for dishwasher if required

Standard Mechanical Requirements

- Hot water, cold water, drain and vent piping for kitchen sink
- Kitchen exhaust fan c/w on/off switch (exhaust to exterior if economical and feasible)
- Supply air diffuser(s) and grilles(s)
- No return air to base building system

Typical Locker Room

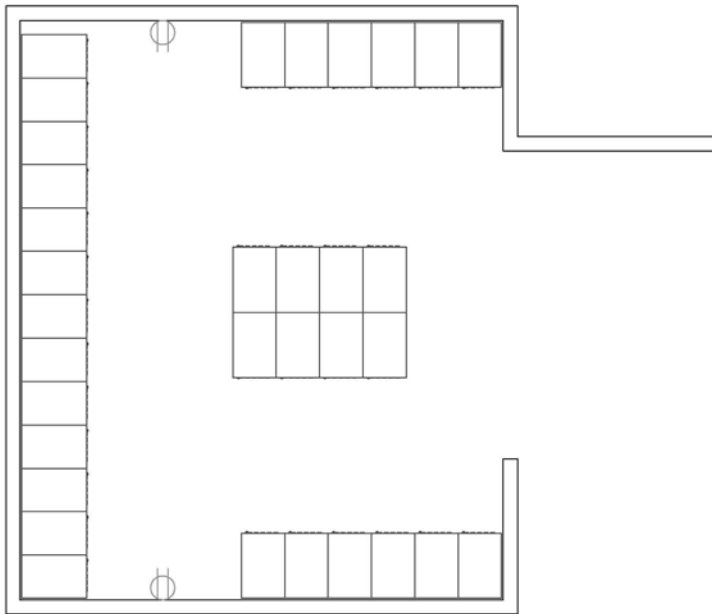

Summary

Space accommodates lockers to suit size of room. Configurations may vary.

Standard Finishes

- Floor – resilient sheet or tile
- Walls – paint or unfinished to suit substrate

Standard Electrical Requirements

- 2 standard electrical duplex receptacles
- Base building lighting with motion sensor

Standard Mechanical Requirements

- Supply and return air diffuser(s)/grille(s)

D5. Costing

D5.1 Cost Estimates

Project managers and project officers are requested to follow the format shown in the example below when preparing their cost estimates for fit-up projects. This breakdown will help to determine those types of fit-up elements that are more often associated with increased costs.

This costing example is based on Plan Example in D3.2 Sample Plan PL1 diagram. A blank version of this form is available in A9.1 Workplace 2.0 Fit-up Cost Estimate Template.

Call/Contact Centre Fit-up

Usable Floor Area: 1,829.0 m²

Cost Summary:

Fit-up Component	Total Cost Estimate	\$/m ²
Partitions	146,320	80
Doors and Frames (including hardware)	64,015	35
Finishes	87,792	48
Millwork and Specialties	31,093	17
Plumbing	23,777	13
HVAC	106,082	58
Fire Protection	40,238	22
Electrical (including lighting modifications)	186,558	102
General Requirements ¹	102,424	56
Panels/screens (including service conduits, power receptacles and voice/data outlets)	495,659	271
Fit-up Total	1,283,958	702

¹ Includes insurance, bonding, site office and supplies, site safety and security and materials handling.

Note:

1. Estimate based on 2012-2013 cost data.
2. Special purpose space not included in cost summary.

Variables that could impact fit-up costs include but are not limited to the following:

- project size;
- ceiling heights;
- specific detailing of partition assemblies;
- specific design features;
- existing conditions (e.g. need to relocate a fire extinguisher or fire hose cabinet, a non-uniform layout of sprinklers or air supply/returns, etc.); and
- call/contact centre support spaces.



Resources



R1. Glossary

Base Building

The building shell including finished floors, exterior walls, interior core and demising walls, finished ceilings complete with lighting, and other building systems consistent with the designed function and planned general use of the building. In the case of office accommodation, for example, the base building would include exterior window coverings and primary identification signage.

BMP/WPM (Building Management Plan/Work Plan Monitoring)

The BMP is a facility-specific annually costed work plan. BMPs are developed consistent with Asset Management Plans (AMPs) and Community-based Investment Strategies (CBIS). The BMP will normally contain information on costs and revenues, trends, levels of service and planned projects. The BMP is a planning tool for initial allocation. In-year adjustments are made through Work Plan Monitoring (WPM). Source: <http://source.tpsgc-pwgsc.gc.ca/rps/ims/bis/tcg/content/pgbmp/mmbldmngd-e.html>.

Circulation Space

Space allowed for movement of personnel between workstations. It includes the space for access to support space and building services.

Cyclical Maintenance

Repair or replacement of standard base building and fit-up components at the end of their useful life, on a cyclical basis (normally 10-15 years). Examples of standard base building and fit-up components include: carpet, ceiling tiles, paint, screens (replace or “re-skin” as required). Source: *Asset and Facilities Management Services – Glossary/Definitions/References*.

Expansion

Increase to the total space in a client department's inventory to accommodate program growth.

Expansion Control Framework (ECF)

Expansion space for non-reimbursing client departments that is beyond their space envelope limit and, therefore, is funded by client departments. Source: *Expansion Control Framework Policy*.

FAH (Federal Accommodation and Holdings Program)

Effective management of real property investment under the custodianship of PWGSC in support of the delivery of government programs. Source: <http://www.tbs-sct.gc.ca/dpr-rmr/2007-2008/inst/svc/svc02-eng.asp#services1>

1. The Federal Accommodation Program meets the accommodation needs of federal organizations by providing and maintaining a cost-effective portfolio of office facilities and common-use assets. The program is mandatory for PWGSC to provide, and for other federal departments to use, with the exception of Crown Corporations.
2. The Federal Holdings Program manages a diverse portfolio of federal facilities such as northern housing (owned and leased), specific properties, marine structure, land transportation in the custody of the Minister of PWGSC, and surplus properties for which PWGSC is designated as the “custodian of last resort”. Source: *PWGSC Real Property Management Framework*.

Fit-up for Initial Occupancy

The preparation of accommodation for initial federal occupancy in accordance with the Government of Canada Workplace 2.0 Fit-up Standards. This fit-up may include alterations or improvements to the base building and/or base building systems, including demolition. A list of fit-up items that PWGSC provides for initial occupancy is included in A3.3 Fit -Up Components and Funding Accountabilities.

Fit-up of Existing Space for Reuse (Refit)

Work required to alter space previously occupied by one federal organization, to meet the requirements of a different federal organization. The scope of the fit-up for reuse is determined by taking into consideration the life cycle approach, the functional requirements of the new client, existing conditions of the previously occupied space, and the duration of the new occupancy. The fit-up of existing space does not apply to leased inventory, and is not always directly connected to the term of an Occupancy Instrument.

Fit-up Rates

PWGSC establishes fit-up rates for general purpose office space in major urban centres across the country. The rates are based on the cost of all standard fit-up components. They are updated annually and are to be used as a budgeting mechanism when preparing cost estimates for fit-up projects for general administrative, public contact and quasi-judicial office space, and as a funding limit for fit-up projects for ministerial and deputy head accommodation. (See A8.1 Workplace 2.0 Fit-up Rates.)

Floor Plate

The size and shape of the floor of a particular building.

Forced Move by PWGSC

A PWGSC initiated move required prior to the termination of an existing occupancy. Source: *Forced Moves – Changes in Occupancy Policy*.

Functional Program

A detailed statement of the accommodation requirements of a client department or agency in relation to a specific fit-up or tenant service project. It supports the space allocation and fit-up standards by describing any qualitative and quantitative gaps between the standards and what is needed by a department or agency to perform its activities efficiently, effectively and safely. Requirements that do not comply with the standards are highlighted in the functional program and reconciled or addressed as non-compliant. A gap analysis identifies the differences between the stated requirements and fit-up standards. The data collected informs both the investment analysis and the planning and design process.

The scope of work of a functional program may include:

- ◆ Verification of project requirements;
- ◆ Project schedule;
- ◆ Risk management;
- ◆ Implementation strategies;
- ◆ Sustainability requirements;
- ◆ Workstation requirements;
- ◆ Support space requirements;
- ◆ Special purpose space requirements;
- ◆ Planning alternatives;
- ◆ Communication/data requirements;
- ◆ Security requirements;
- ◆ Proximity/adjacencies requirements;
- ◆ Detailed functional space equation;
- ◆ Scheduling requirements;
- ◆ Class "D" and "C" cost estimate;
- ◆ Schematic design;
- ◆ Vertical/horizontal zoning; and
- ◆ Other special requirements.

Functional programs are funded by PWGSC when required for fit-up projects of non-reimbursing occupancies. Functional programs are funded by client departments when required for fit-up projects of reimbursing occupancies or for tenant service projects.

General Administrative Offices

Offices that accommodate general office functions and activities that do not require special security or other special features. General administrative offices do not have high interface with the public. These offices comprise the majority of PWGSC office space occupied by client departments and agencies.

Heating, Ventilation and Air Conditioning (HVAC) Systems

Mechanical systems that supply or remove heat, supply or remove humidity, and supply outdoor air as required.

Kiosk

Small structure for display or dissemination of information.

Major Renovation

Work undertaken to correct or delay physical or functional obsolescence and/or to extend the useful or economic life of a building. Included are improvements to the building's structure or systems, such as HVAC, lighting, elevators, sprinkler systems.

Occupancy Instrument (OI)

A formal agreement between a department or agency and PWGSC concerning occupancy in a particular asset. It records the rentable and usable areas, the civic address and the planned general use of the particular parcel of accommodation that is subject to the agreement. It also records the terms and conditions that govern the provision and occupancy of the accommodation, as well as charges for accommodation and agreed upon services.

Office Space

Includes office/workstation areas, general support space and circulation for all four generic office types.

Public Contact Offices

Offices accommodating functions that provide face-to-face services to the public. Functions and operations may include, but are not limited to:

- ◆ inquiries from walk-in customers;
- ◆ training/testing/meetings; and
- ◆ application/form processing.

Quasi-judicial Offices

Offices that accommodate adjudicative or legislative functions. They often require confidentiality or enhanced security and are used by organizations that interpret and administer legislation and regulations, conduct inquiries and hearings and/or perform adjudication functions on complaints, appeals and claims. Functions and operations may include, but are not limited to:

- ◆ management: adjudicative body operates separately from the administrative unit which provides service to the adjudicative body;
- ◆ meetings: conducted on a scheduled basis with internal staff and members of the public; and

- ◆ secure and confidential courtroom/hearing room space; physical protection of staff could be required.

Renewal

Renewal of an occupancy instrument or lease agreement at the end of its term to accommodate a client department's continuing requirement for space at the same location. The decision to renew an occupancy instrument or lease is based on an investment analysis. The new occupancy instrument or lease agreement may be for the same or a reduced amount of space. A renewal may also be combined with a client department's requirement for expansion.

Rentable Area

The space used to calculate rental payments. Rentable areas include usable areas and areas such as lobbies, washrooms and electrical rooms. Stairways, entrances and elevators or duct shafts are not included in rental areas.

Replacement

Transfer of existing space in a client department's inventory to a new location at the end of an occupancy instrument. The decision to replace existing space is based on an investment analysis. The relocation may be to new or existing space in the PWGSC inventory.

Secure Administrative Offices

Offices accommodating activities which require enhanced levels of security. Functions and operations may include, but are not limited to:

- ◆ the review and storage of sensitive files; and
- ◆ little or no public contact.

Space Envelope

The total amount of rentable square metres departments can occupy by fiscal year based on authorities received by PWGSC to provide accommodation in accordance with standards, policies and guidelines.

Space Optimization

For Space Optimization, there are generally 2 scenarios: *Densification* or *Space Expansion Avoidance*.

1. *Densification* (to achieve space allocation standards): A densification project (for example, restructuring an office layout to reduce the space utilization rate from 16 m²/FTE to 14 m²/FTE up to the space allocation standards) is not necessarily a funding priority. Real Property Branch (RPB) must prioritize projects and compare densification requests against the urgency of other projects (for example a leaking roof). If RPB can fund a densification project, then the client department's space envelope is reduced as the source of funds.

However, if RPB cannot afford to fund a densification project, then the client department would have to fund the work as a tenant service in order to proceed.

2. **Space Expansion Avoidance:** The objective of this option is to optimize the use of a finite quantity of space in a facility by increasing the density of occupancy in a manner which permits the avoidance of renting space elsewhere, up to the generic space allocation standards. A well substantiated and documented business case must demonstrate the benefits to the Crown with a payback period of not longer than 3 years for projects less than \$1M, up to 5 years for larger projects. RPB would provide standard fit-up and such projects must be submitted to Banking Day in accordance with the call letter. Source: *Space Envelope Procedure – Space Optimization Impact on Space Envelope, April 2009*.

Special Purpose Space (SPS)

Additional, non-standard areas required by a client department to accommodate specific activities that are unique and essential to departmental programs.

Examples of special purpose spaces include, but are not limited to:

- ◆ laboratories, health units or clinics;
- ◆ meeting or training complexes which serve outside groups;
- ◆ interview rooms;
- ◆ inspection rooms;
- ◆ processing space;
- ◆ departmental libraries (e.g. Department of Justice libraries);
- ◆ gymnasiums, warehouses (e.g. PWGSC's Seized Property Management Directorate warehouse space);
- ◆ very large file or storage areas other than allowed by the *Workplace 2.0 Fit-up Standards* (e.g. Canada Revenue Agency (CRA) tax return file storage, Library and Archives storage);
- ◆ trade shops;
- ◆ large mailrooms (e.g. CRA's mailroom);
- ◆ computer training rooms;
- ◆ cash offices or similar spaces requiring special service and security features; and
- ◆ hearing rooms.

Specific Service Agreement (SSA)

An internal PWGSC contract between one of the service branches and another government unit. It describes the work to be done, the schedule and the cost of the work.

Support Space

Spaces for office support functions not included in the workstation, or circulation space but necessary for office operation. Support space includes meeting rooms, quiet rooms, collaborative areas, kitchenettes, shared equipment areas, printer stations, reception/waiting areas, and other areas as described in A3.4 Office and Support Space Allocations.

Swing Space

Temporary office space used to accommodate client departments while their long term office space is under renovations or until new office space is available. Minimal fit-up is required for swing space.

Task Lighting

Lighting oriented to or located at a task position is generally called task lighting. Task lights located at the task area are usually used in conjunction with ambient or general lighting and are client funded.

Tenant Services

Alterations to existing accommodation requested and funded by a client and carried out during the term of an occupancy.

Usable Area

Office floor area available to the tenant. Columns and such are not included in usable area.

Workstation

Workspace provided for an individual employee and his/her directly associated furniture and equipment.

R2. Closed Office Assignments

The following table demonstrates closed office assignments in typical departmental organizational hierarchies.

Boxes identified by a darker outline indicate the lowest level that may be assigned a closed office, in accordance with A3.4 Office and Support Space Allocations.

DEPT A	DEPT B	DEPT C	DEPT D	DEPT E	DEPT F	DEPT G	DEPT H
Deputy Head or Associate Deputy Head	Deputy Head or Associate Deputy Head	Deputy Head or Associate Deputy Head	Deputy Head or Associate Deputy Head	Deputy Head or Associate Deputy Head	Deputy Head or Associate Deputy Head	Deputy Head or Associate Deputy Head	Deputy Head or Associate Deputy Head
-	-	-	EX5 Executive Vice-president	EX5 Deputy Commissioner	EX5 Assistant Deputy Minister	-	-
-	EX4 Deputy Chairman	EX4 Assistant Deputy Minister	EX4 Vice-president	-	EX4 Executive Director	-	-
-	EX3 Assistant Deputy Chairman	EX3 Director General	-	EX3 Assistant Commissioner	EX3 Director General	EX3 Director General	-
-	-	-	EX2 Executive Director	EX2 Chief Superintendent	EX2 Director (w/15 reports)	-	EX2 Director
-	EX1 Coordinating Member	EX1 Director	EX Equiv. Director (w/12 reports)	-	EX1 (w/7 reports)	-	-
-	-	EX Equiv. (w/10 reports)	-	EX Equiv. Superintendent (w/13 reports)	-	EX Equiv. Director	EX Equiv. (w/15 reports)
AS6 Most Senior Departmental Representative	-	-	-	Inspector	-	EX Minus 1 (w/10 reports)	-

