

## REQUEST FOR A STANDING OFFER (RFSO)

ADDRESS ENQUIRIES TO: Allan Lapensée, Sr. Contract Officer <a href="mailto:Allan.lapensee@ncc-ccn.ca">Allan.lapensee@ncc-ccn.ca</a>	BID DEADLINE:  May 17, 2017 at 3pm EDT
RETURN TO: Submit your proposal, price envelope and this page signed and return to:	→ National Capital Commission Procurement Services 40 Elgin Street 2 <sup>nd</sup> floor security office Ottawa, ON K1P 1C7 Reference NCC tender file # AL1700

**This page is to be dated, signed and returned with your proposal, thereby acknowledging having read, understood and accepted the terms of reference of this RFSO and any/all other attachments referred to herein.**

We hereby OFFER to sell and/or supply to the National Capital Commission upon the terms and conditions set out herein, the supplies and/or services listed above and on any attached sheets at the submitted price(s).	
Bidder's Name & Address     Tel:  Fax:  Email:	Print Name   Signature   Date
ADDENDUM ACKNOWLEDGEMENT: I/We acknowledge receipt of the following addendums and have included for the requirement of it/them in my/our tendered price:	_____ _____ Bidder to enter the number of addendums issued (i.e. #1, #2, etc.) if any.

## 1.0 INSTRUCTIONS TO BIDDERS

- 1.1 Submit page 1 of this RFSO, a technical proposal in four (4) duplicate copies and one price envelope to provide services to the National Capital Commission's (referred to as the "Commission" or the "NCC") Terms of Reference document attached herewith. The proposal can be submitted in either official language.
- 1.2 Enquiries regarding this proposal must be submitted in writing to Allan Lapensée , Sr. Contract Officer, at e-mail address [allan.lapensee@ncc-ccn.ca](mailto:allan.lapensee@ncc-ccn.ca) as early as possible within the solicitation period. Enquiries should be received no later than seven (7) calendar days prior to the date set for solicitation closing to allow sufficient time to provide a response. Enquiries received after that time may result in an answer not being provided. To ensure consistency and quality of the information provided to all Proponents, the Senior Contract Officer shall examine the content of the enquiry and shall decide whether or not to issue an amendment. All enquiries and other communications related to this proposal sent throughout the solicitation period are to be directed **ONLY** to the Senior Contract Officer named above. Non-compliance with this requirement during the solicitation period can, for that reason alone, result in disqualification of a proposal.
- 1.3 The technical proposal is to include all information as defined in the Terms of Reference (see appendix 2).
- 1.4 The price schedule form (see appendix 3 of the terms of reference) must be enclosed in an envelope separate from the technical proposal documents. Unless otherwise specified by the NCC, the prices quoted shall be net prices in Canadian funds excluding taxes, F.O.B Destination: National Capital Region, including all costs as detailed in the terms of reference.
- 1.5 As a green initiative, the NCC requests that the Bidder's Technical Proposal follow these green practices:
  - use recycled paper products
  - print double sided
  - use a maximum font of 11
  - no binders and/or plastic sheets (note plastic/metal spirals are acceptable)
- 1.6 All proposals will be evaluated against mandatory requirements compliance. Then, proposals are scored according to the rated requirements and evaluation criteria. Proposals meeting all mandatory requirements and obtaining a minimum score of 60% for the technical component will be considered as technically admissible. The price form must be submitted in a separate sealed envelope and will be opened only for all technically admissible proposals. The selected proposal will be the one that submits the lowest total amount. The NCC intends to award a minimum of one (1) Standing Offer Agreement.
- 1.7 A debriefing of a Proponent's Technical Proposal will be provided, if requested to the NCC Project Manager identified in the letter of notification of contract award, within 15 days of receipt of this notice. The debriefing will include an outline of the reasons the submission was not successful.
- 1.8 If any supplier holding an SOA has their SOA terminated, the NCC reserves the right to 'replenish' the list of SOAs, by offering an SOA to another supplier. The basis for deciding which suppliers are offered 'replenishment' SOAs shall be 'the next ranked supplier(s)' as per rankings established above.

- 1.9 The Commission is a Crown Corporation subject to the Goods and Services Tax (GST) and the Provincial Sales Tax (HST or QST). The successful supplier will be required to indicate separately, with the request for payment, the amount of GST and HST/QST, to the extent applicable, that the Commission will pay. These amounts will be paid to the successful Bidder who will be required to make the appropriate remittances to Revenue Canada and the respective provincial governments. The successful bidder(s) must complete & return the T1204 form and attach a voided cheque for direct deposit purposes.
- 1.10 The Occupational Health & Safety Requirements, the Security Requirements and the General Conditions will also form part of the resulting SOA and subsequent call-up purchase order(s).
- 1.11 In order to avoid any misunderstanding and be fair to all suppliers, please note that proposals received after the closing time and date will not be accepted.
- 1.12 The Commission reserves the right to not accept the lowest or any of the proposals submitted, to cancel the RFSO, and/or to reissue the RFSO in its original or revised form. The Commission also reserves the right to negotiate with the successful proponent and/or any/all proponents.
- 1.13 Facsimile transmittal of proposals will not be accepted.
- 1.14 Proposals will be held in strict confidence. There will not be a public opening of the proposals submitted for this RFSO. Notwithstanding the foregoing, proponents are advised that as a Crown Corporation, the Commission is subject to the provisions of the *Access to Information Act*. Information submitted by third parties will only be exempted from disclosure if the records or part of them qualify for an exemption under the ATI Act.
- 1.15 This RFSO, SOA and call-up purchase order(s) resulting from this process is to be interpreted, construed, governed by, and the relation between parties is to be determined in accordance with the laws of the Province of Ontario and such Federal laws applicable therein.
- 1.16 The Commission shall not be obligated to reimburse or compensate any proponent, its sub-contractors or manufacturers for any costs incurred in connection with the preparation of a response to this RFSO. All copies of proposals submitted in response to this RFSO shall become the property of the Commission and will not be returned.
- 1.17 This RFSO and all supporting documentation have been prepared by the Commission and remain the sole property of the Commission, Ottawa, Canada. The information is provided to the proponent solely for its use in connection with the preparation of a response to this RFSO and shall be considered to be the proprietary and confidential information of the Commission. These documents are not to be reproduced, copied, loaned or otherwise disclosed directly or indirectly, to any third party except those of its employees having a need to know for the preparation of the Bidder's response, and the Bidder further agrees not to use them for any purpose other than that for which they are specifically furnished.

- 1.18 The successful Bidder shall indemnify and save harmless the Commission from and against all claims, damages, costs and expenses sustained or incurred by the Commission resulting from any action or legal proceeding on infringement, made, sustained, brought, prosecuted, threatened to brought or prosecuted, by any person that was under the direction and control of the Bidder during the term of the resulting SOA and call-up purchase order(s) and which person is claiming or claims a moral right, as set out under the Copyright Act. The obligation to indemnify under this clause survives termination of the resulting SOA and call-up purchase order(s) and will remain in force for the duration of the copyright in the work created under the resulting SOA and call-up purchase order(s). This obligation to indemnify relative to alleged moral rights infringement(s) is in addition to the Bidder's other obligations to indemnify and save harmless which are set out in the Commission's General Conditions.

## 2.0 REQUEST FOR STANDING OFFER AGREEMENT

### 2.1 INTRODUCTION

One method of supply used by the NCC to satisfy the requirements of identified internal users is to arrange a Standing Offer Agreement (SOA) to provide goods, services or both to the NCC during a specified period. The identified internal users to be served may then be a delegated purchasing authority and may access the source of supply directly, as and when requested, by issuing purchase orders detailing the exact quantities of goods or services they wish to order from the Offeror at a particular time during the effective period of the Offeror's offer and in accordance with the predetermined conditions. This method of supply is particularly useful in acquiring frequently ordered commercially and non commercially available goods or services when the total volume or value of goods or level of services that may be required by one or more identified users can be estimated beforehand, but it is not possible at the outset to identify the exact requirements for any given user at a specific time in the future.

The NCC foresees a potential need for **ASPHALT PATCH WORK AND REPAIRS**, as more particularly stated herein and in the attached; you are hereby invited to provide to the NCC a Standing Offer. If you wish to submit an offer you are required to do so, on the enclosed forms and format. Please be advised that the quantity of goods and/or services and the estimated expenditure specified in the attached are only an approximation of requirements given in good faith. The making of a standing offer by the Offeror shall not constitute an agreement by the NCC to order any or all of the said goods and/or services. The NCC may make one or several purchase orders against a Standing Offer, each such purchase orders constituting an acceptance of said Standing Offer for the part of the said goods or services described in the purchase order. A request does not commit the NCC to authorize the utilization of a Standing Offer or to pay any cost incurred in the submission of offers, or cost incurred in making necessary studies for the preparation thereof, or to procure or contract for any goods or services. The NCC reserves the right to reject or authorize for utilization any offer in whole or in part, with or without further discussion or negotiation.

### 2.2 GENERAL PROVISIONS

The Offeror acknowledges that a Standing Offer is not a contract. The Offeror offers to sell or provide and deliver to the NCC, upon the terms and conditions hereinafter set out, the goods and/or services detailed herein and at the prices listed herein or on the pricing basis set out herein, AS AND WHEN REQUESTED by authorized NCC users such goods and/or services the authorized user orders, in accordance with the following provisions.

It is understood and agreed that:

- a purchase order against a Standing Offer shall form a contract only for those goods or services, or both, which have been ordered, provided always that such a purchase order is made in accordance with the provisions of the Standing Offer;
- the issue and distribution of the authorization to use any resulting Standing Offer does not oblige the NCC to authorize or order all or any of the goods and/or services described in the Standing Offer;
- The NCC's liability shall be limited to that which arises from purchase orders against any resulting Standing Offer made within the period specified herein;
- The NCC reserves the right to procure the specified goods and/or services by means of contracts, standing offers, or by other contracting methods.

2.3 STANDING OFFER REQUIREMENT:

The National Capital Commission (NCC) wishes to retain the services of a **qualified contractor** as detailed in the Terms of Reference on an "as and when requested" basis under a Standing Offer Agreement.

The term proponent, used throughout this document, is defined as the entity submitting a proposal and shall mean a supplier, an entity formed through a prime Bidder/sub-Bidder relationship, a consortium or a joint venture. Proponents shall provide all of the required services enumerated within the terms of reference.

To ensure equal opportunities for all proponents, and to eliminate risk of conflict of interest, all proponents are advised that the National Capital Commission will not accept more than one submission per supplier, whether the supplier applies as a single entity, part of a joint venture, or as a sub-consulting member of the team.

2.4 PERIOD OF THE STANDING OFFER AGREEMENT:

The duration of the SOA is for a period of two and half (2.5) years from the date of award to end of November 2019.

2.5 CALL-UP PURCHASE ORDER DOCUMENT:

The authorized "Purchase order Against a Standing Offer" document will be NCC Purchase Order # XXXXXX. The purchase order document shall specify the supplier name and address, Purchase Order number, delivery date required, delivery location, description of goods or services performed quantities, unit prices, purchase order limit, and an approval signature to proceed by the authorized designated user.

2.6 CALL-UP PURCHASE ORDER LIMITATION:

The maximum all-inclusive amount payable for any one purchase order (call-up) shall be \$75,000 CDN including applicable taxes.

Services should not be delivered until NCC's Contracts has issued a purchase order number specific to that call-up purchase order.

If no extra services are authorized by the NCC Project Manager, the written quotation shall constitute the maximum amount payable under the call-up purchase order.

2.7 ESTIMATED SOA EXPENDITURE:

The combined estimated expenditure for all Standing Offer Agreements is \$ 300,000 CDN including taxes. As operational requirements become more defined, the NCC reserves the right to increase the total estimated expenditure by 10% but in no circumstance will the total estimated expenditure for the SOA(s) be more than \$ 330,000 including taxes.

The NCC reserves the right to terminate the SOA of any supplier that shows repeated failure to satisfactorily manage the quality of the goods and/or timeliness of delivery.

2.8 INVOICING:

Send the original and two (2) copies of the invoice directly to:  
National Capital Commission  
Accounts Payable  
202, 40 Elgin St., 3<sup>rd</sup> floor  
Ottawa, Ontario, K1P 1C7

Or, in an effort to promote the electronic transmission of invoices to our Accounts Payables department, the National Capital Commission is encouraging its suppliers to transmit their invoices as an attachment via e-mail to the following address [payables@ncc-ccn.ca](mailto:payables@ncc-ccn.ca). For storage purposes it would be preferable that the file format of the attachment be saved in a .jpg format.

To ensure prompt payment, please prepare your invoice in accordance with the prices quoted. Errors in invoicing can cause delay of payment. Submit your invoice to the address shown on the Purchase Order and clearly indicate the Purchase Order number.

Itemized invoices are to be submitted to NCC Accounts Payable at intervals of not less than 30 days.

2.9 NOTIFICATION OF WITHDRAWAL OF STANDING OFFER:

In the event the Offeror wishes to withdraw their offer, they will inform the NCC with a minimum of 30 days prior written notice. Any withdrawal of the offer will not affect any purchase orders made prior to the 30 days written notification.

---

## GENERAL CONDITIONS

---

### 1. Definition of Terms

In the Contract,

1. the "Project Manager/Officer" means such person as may be specifically designated by or on behalf of the Chairman and/or Executive Vice-President and General Manager upon the award of this contract.
2. "work" includes the whole of the works, Labour and materials, matters and things to be done, furnished and performed by the Contractor under the contract.

### 2. Assignment and Subcontracting

This contract may not be assigned without the written consent of the Commission, and neither the whole nor any part of the work may be subcontracted by the Contractor without the consent of the Project Manager/Officer. Every subcontract shall incorporate all the terms and conditions of this contract which can reasonably be applied thereto.

### 3. Members of The House of Commons

No member of the House of Commons shall be admitted to any share or part of the contract or to any benefit arising therefrom.

### 4. Indemnification

The Contractor shall indemnify, and save harmless the National Capital Commission from and against all claims, losses, costs, damages, suits, proceedings, or actions arising out of or related to the Contractor's activities in executing the work, other than those arising from a defect in title to the site of the work or the infringement of a patent arising from a design supplied by the National Capital Commission, but including his omissions improper acts or delays in executing the work under the contract.

### 5. Property of the National Capital Commission

The Contractor shall be responsible for any loss of or damage, excluding reasonable wear and tear, to any property of the National Capital Commission arising out of the performance of the work whether or not such loss arises from causes beyond his control. Such property shall only be used by the Contractor as may be directed by the Project Manager/Officer and the Contractor shall, at any time when requested to do so, account to the Project Manager/Officer for the use of such property.



---

## **GENERAL CONDITIONS**

---

### **6. Permits and By-Laws**

The Contractor shall comply with all laws and regulations, relating to the work whether federal, provincial or municipal, as if the work was being constructed for a person other than the National Capital Commission and shall pay for all permits and certificates required in respect of the execution of the work.

### **7. Canadian Labour and Materials**

Insofar as is practicable the Contractor shall employ and use Canadian labour and materials in the execution of the work and utilize the services of the Canada Manpower Centre in the recruitment of such labour.

### **8. Publicity**

1. The Contractor will neither permit any public ceremony, nor erect or permit the erection of any sign or advertising, in connection with the work without the approval of the Project Manager/Officer.
2. All exterior signs erected by the contractor will be in both official languages and subject to NCC approval.

### **9. Materials, Equipment, etc. to become Property of the National Capital Commission**

All materials and plants used or provided for the work shall be the property of the National Capital Commission, shall not be removed from the site of the work and shall be used only for the purpose of the work, until the Project Manager/Officer shall certify that they are, if not incorporated in the work, no longer required for the purpose of the work. The Contractor shall be liable for all loss or damage to materials or plants that are the property of the National Capital Commission by virtue of this section.

### **10. Contractor's Superintendent and Workers**

The Contractor will keep a competent superintendent on the site of the work at all times during the progress of the work unless otherwise authorized by the Project Manager/Officer. The superintendent must be acceptable to the Project Manager/Officer and have the authority to receive on behalf of the Contractor any order or communication in respect of the contract. Any superintendent and workers not acceptable to the Project Manager/Officer because of incompetency, improper conduct or security risk will be removed from the site of the work and replaced forthwith.

---

## **GENERAL CONDITIONS**

---

### **11. Co-operation with other Contractors**

The Contractor will co-operate fully with other contractors or workers sent onto the site of the work by the Project Manager/Officer. If the sending onto the work of other contractors and workers could not have been reasonably foreseen by the Contractor when entering into the contract, and if, in the opinion of the Project Manager/Officer the Contractor has incurred additional expense by such action, and if the Contractor has given written notice of claim within thirty days of such action, the National Capital Commission will pay the cost of such additional expense to the Contractor calculated in accordance with Section 20.

### **12. Claims Against and Obligations of the Contractor or Subcontractor**

1. The Contractor shall ensure that all his lawful obligations and lawful claims against him arising out of the execution of the work are discharged and satisfied, at least as often as this contract requires the National Capital Commission to discharge its obligations to the Contractor and shall supply the Project Manager/Officer with a Statutory Declaration deposing to the existence and condition of such claims and obligations when called upon to do so.
2. The National Capital Commission may, in order to discharge lawful obligations and satisfy lawful claims against the Contractor or a subcontractor arising out of the execution of the work, pay any amount, which is due and payable to the Contractor under the contract and from a conversion or a negotiation of the security referred to in Section 18 hereof, if any, directly to the obligees of and the claimants against the Contractor or the subcontractor.

### **13. Project Manager/Officer's Rights and Obligations**

The Project Manager/Officer shall:

1. have access to the work at all times during its execution and the Contractor will provide the Project Manager/Officer with full information and assistance in order that he may ensure that the work is executed in accordance with the contract;
2. decide any question as to whether anything has been done as required by the contract or as to what the Contractor is required by the contract to do, including questions as to the acceptability of, the quality or quantity of any labour, plant or material used in the execution of the work, and the timing and scheduling of the various phases of the work;
3. have the right to order additional work, dispense with, or change the whole or any part of the work provided for in the plans and specifications. The Project Manager/Officer shall decide whether anything done or not done as a result of directions given under this subsection has increased or decreased the cost of the work to the Contractor and the amount payable under the contract to the Contractor will be increased or decreased accordingly by an amount calculated in accordance with Section 20 hereof.

The Contractor shall comply with any decision or direction of the Project Manager/Officer given under this section.

---

## GENERAL CONDITIONS

---

### **14. Delay, Non-compliance, or Default by the Contractor**

If the Contractor delays in the commencement, execution or completion of the work, fails to comply with a direction or decision of the Project Manager/Officer properly given, or is in default in any other manner under the contract, the Project Manager/Officer may do such things as he deems necessary to correct the Contractor's default.

The Contractor will reimburse the National Capital Commission for all costs, expenses and damages incurred or sustained by the National Capital Commission, by reason of the Contractor's default, or in correcting the default. In addition to the aforementioned remedies in this section, the Commission may, if the default continues for 6 days after notice in writing of default has been given to the Contractor by the Project Manager/Officer, terminate the contract in accordance with Section 17.

### **15. Changes in soil conditions, National Capital Commission delays**

1. The Contractor will receive no additional payment for additional costs incurred due to loss, damage or any other reason whatsoever, without the express certification of the Architect/Engineer that the additional cost, loss or damage is directly attributable to:
  - i) in the case of a flat-rate contract, a significant difference between the soil condition information contained in the plans and specifications and actual on-site soil conditions;
  - ii) negligence or delay on the part of the National Capital Commission, following the contract signing date, in providing complete information or in executing its full contract responsibilities or, according to current trade practice, the Contractor has submitted to the Architect/Engineer a written notice of claim for additional costs, loss or damages, not later than thirty (30) days following the date on which the varying soil conditions were noticed, or the date on which said negligence or delay commenced. The amount of any additional payments to be issued under this article will be calculated as per Article 20.
2. If, in the opinion of the Architect/Engineer, the Contractor has ensured a savings due to the differing soil conditions cited above, the amount of this savings will be deducted from the total price of the Contract stated in Article 1 of the Offer and Agreement.

### **16. Protesting Project Manager/Officer's Decision**

If the Contractor, within 10 days of receiving any decision or direction of the Project Manager/Officer, gives written notice to the Project Manager/Officer that the decision or direction is accepted under protest, the National Capital Commission will pay to the Contractor the cost, calculated according to Section 20, of anything that the Contractor was required to do, as a result of the decision or direction, beyond what the contract correctly understood would have required him to do.

---

## **GENERAL CONDITIONS**

---

### **17. Suspension or Termination of the Contract**

1. The Commission may upon notice in writing to the Contractor suspend or terminate the contract at any time. The Contractor will comply with such notice immediately.
2. If the Commission suspends the work for 30 days or less the Contractor must, subject to his remedy under Section 15 hereof, complete the work when called upon to do so. If the Commission suspends the work for a period in excess of 30 days the Contractor may request the Commission to terminate the work under sub-section 4 hereof.
3. If the Commission terminates the contract because of default by the Contractor, the insolvency of or the commission of an act of bankruptcy by the Contractor, the obligations of the National Capital Commission to make payments to the Contractor shall cease and no further payments shall be made to the Contractor or less the Project Manager/Officer shall certify that no financial prejudice will result to the National Capital Commission from such further payments. Termination under this sub-section shall not relieve the Contractor of any legal or contractual obligations other than the physical completion of the work. In such circumstances the Project Manager/Officer may complete or have the work completed as he sees fit and all costs and damages incurred by the National Capital Commission due to the non-completion of the work by the Contractor shall be payable by the Contractor to the National Capital Commission.
4. If the Commission terminates the work other than in accordance with sub-section 3 hereof, the National Capital Commission will pay to the Contractor an amount calculated in accordance with Section 20 hereof subject to any additions or deductions otherwise provided by the General Conditions or Labour Conditions less any payments made pursuant to Section 25.3, hereof. In no event, however, shall such amount be greater than the amount which would have been payable to the Contractor had the contract been completed.

### **18. Security Deposit**

If any security deposit is provided by the Contractor pursuant to this contract it shall be dealt with in accordance with the Government Contracts Regulations, provided that if the Contractor is in breach or default under the contract the National Capital Commission may convert or negotiate such security to its own use. If a Labour and Material Payment Bond is provided pursuant to the contract the Contractor shall post on the site of the work a notice to that effect which shall include the name and address of the Surety, definition of those persons protected therein and an outline of the procedure for submitting a claim.

### **19. No Additional Payment**

The amount payable to the Contractor under this contract will not be increased or decreased by reason of any increase or decrease in the cost of the work brought about by any increase or decrease in the cost of plant, labour or material, except that, in the event of a change in any tax, that affects the cost of any materials incorporated or to be incorporated in the work, imposed under the Excise Act, the Excise Tax Act, the Old Age Security Act, the Customs Act or Customs Tariff, made public after the date of the submission of the tender, an appropriate adjustment may be made.

---

## GENERAL CONDITIONS

---

### **20. Determination of Costs**

For the purposes of Section 11, 13.3, 15, 16 and 17.4, the amount payable to the Contractor shall, subject to the provisions of Section 25.2.ii) hereof, be based on the unit prices, if any, set out in Clause 4 of the Offer and Agreement. If such unit prices are not applicable the Project Manager/Officer and the Contractor may mutually agree on the amount payable. Failing such agreement the amount payable shall be the reasonable and proper expenses paid or legally payable by the Contractor directly attributable to the work plus 10% of such expenses to cover overhead, including finance and interest charges, and profit, as certified by the Project Manager/Officer.

### **21. Records to be Kept by Contractor**

1. The Contractor shall maintain full records of his estimates of and actual cost to him of the work together with all proper tender calls, quotations, contracts, correspondence, invoices, receipts and vouchers relating thereto, shall make them available to audit and inspection by the Commission, or by persons acting on its behalf, shall allow them to make copies thereof and to take extracts therefrom, and shall furnish them with any information which they may require from time to time in connection with such records.
2. The records maintained by the Contractor pursuant to this section shall be kept intact until the expiration of two years from the date of issuance of the Final Certificate of Completion under sub-section 24 of the General Conditions or until the expiration of such other period as the Commission may direct.
3. The Contractor shall require all subcontractors and all firms, corporations and persons directly or indirectly having control of the Contractor to comply with Sections 1 and 2 as if they were the Contractor.

### **22. Extension of Time**

The Commission may, on the application of the Contractor, made before the day fixed for the completion of the work, extend the time for completion of the work. The Contractor shall pay to the National Capital Commission an amount equal to the National Capital Commission's expenses and damages incurred or suffered by reason of the delay in completion of the work unless in the opinion of the Commission such delay was due to causes beyond the control of the Contractor.

### **23. Cleaning of Work**

The Contractor will upon completion of the work, clear and clean the work and its site to the satisfaction of and in accordance with any directions of the Project Manager/Officer.

---

## GENERAL CONDITIONS

---

### 24. Project Manager/Officer's Certificates

On the day that the work has been completed and the Contractor has complied with the contract and all orders and directions pursuant thereto to the satisfaction of the Project Manager/Officer, the Project Manager/Officer will issue to the Contractor a Final Certificate of Completion. In the case of a unit price contract, the Project Manager/Officer will at the same time issue a Final Certificate of Measurement setting out the final quantities used or employed in respect of the classes and units set out in the Unit Price Table, and any subsequent amendments thereto, under Clause 4 of the Offer and Agreement, such certificate to be binding upon the Contractor and the National Capital Commission.

### 25. Payment

1. The National Capital Commission will pay and the Contractor will accept as full consideration for the work performed and executed an amount by which the amount referred to in Clause 1 of the Offer and Agreement together with the aggregate of the amounts payable by the National Capital Commission under Section 11, 13.3, 15.1, 16 and 19 minus the aggregate of any payments by the National Capital Commission under Section 12 and indemnification and amounts payable to or costs and damages incurred by the National Capital Commission under Sections 4, 5, 9, 13.3, 14, 15.2, 17.3, 19 and 22.
2. In the case of a unit price contract:
  - i) The amount referred to in Clause 1 of the Offer and Agreement will be deemed to be the amount computed by totalling the products of the unit prices set out in Clause 4 of the Offer and Agreement, as amended pursuant to sub-paragraph ii) hereof, if applicable, and the actual quantities of such units as set out in the Project Manager/Officer's Final Certificate of Measurement, subject to and, adjustment provided for in sub-paragraph ii) of this sub-section.
  - ii) The Project Manager/Officer and the Contractor may, by agreement in writing, add to the aforesaid Unit Price Table other classes of labour, etc., units of measure, estimated quantities and prices per unit, and may if the actual quantities as set out in the aforesaid Final Certificate of Measurement exceed or fall short of the estimated quantities in respect of any item(s) shown in the aforesaid Unit Price Table by more than 15% amend the unit prices shown in the Unit Price Table for such items, provided that in the event the actual quantities exceed the estimated quantities by more than 15% the aforementioned amendment to the unit prices shall apply only to the actual quantities in excess of 115% of the estimated quantities. Where the Project Manager/Officer and the Contractor fail to agree on the amount of any adjustment as contemplated by this sub-section the revised or new prices per unit shall be determined in accordance with Section 20 hereof.

---

## GENERAL CONDITIONS

---

3. If the amount of the Contract is in excess of \$5,000 the Contractor shall be entitled to receive progress payments upon submitting Progress Claims which must be approved by Progress Reports issued by the Project Manager/Officer at monthly intervals. The amount to be paid to the Contractor for a progress payment shall be 90% of the value of the work certified by the Project Manager/Officer in the Progress Report as having been completed since the date of the immediately preceding Process Claim, if any, when a Labour and Material Payment Bond has been furnished under the contract the amount to be paid under this sub-section shall be 95% of the value certified by the Project Manager/Officer.
4. Sixty (60) days after the issue by the Project Manager/Officer of the Final Certificate of Completion there shall become due and payable to the Contractor the amount described in sub-section 1 of this section less the aggregate of the amounts, if any, paid pursuant to sub-section 3 of this section.
5. Notwithstanding sub-sections 3 and 4 of this section, no payments shall be due or payable to the Contractor if he has failed to supply any Statutory Declaration pursuant to Section 12, surety bond or security deposit pursuant to Clause 5 of the Offer and Agreement.
6. A payment by the National Capital Commission pursuant to this section shall not be construed as evidence that the work is satisfactory or in accordance with the contract.
7. Delay in making a payment by the National Capital Commission under this section shall not be deemed to be breach of the contract. However, subject to sub-section 5 of this section, if payment of any Progress Claim under sub-section 3 of this section is not made within 60 days of the date of receipt of the Contractor's Progress Claim, such Progress Claim shall be deemed to be overdue and the Contractor shall be entitled to interest at the rate of 5% per annum of the amount overdue for the period commencing at the end of the forty-fourth day after the said date of receipt of the Progress Claim and ending on the date paid.
8. The National Capital Commission may set-off against any amount payable or debt due by the National Capital Commission under this contract the amount of any debt due to the National Capital Commission under this contract or any other contract between the Contractor and the National Capital Commission.

### **26. Correction of defects**

Should the Contractor receive notice from the Architect/Engineer requiring the correction, at the Contractor's expense, of any defect or vice, regardless the cause, the Contractor will complete the necessary corrections on or before the deadline specified in said notice, in the event that the defect or vice becomes evident not later than twelve (12) months following the date of the Final Certificate of Completion.

---

## GENERAL CONDITIONS

---

**27. Liability Insurance**

The Contractor shall, at its own expense, purchase, provide and maintain in force for the duration of the contract comprehensive general public liability insurance, naming the Commission as co-insured, against claims for personal injury (including death) or property damage or public liability claims due to any accident or occurrence, arising out of or in connection with the execution of the contract, indemnifying and protecting the Commission to a limit of not less than five million (\$5 000 000.00) per occurrence. There shall be no right of subrogation of the Contractor or the insurer and the policy of insurance shall contain a severability of interests clause. The Contractor shall provide the Commission with a copy of the certificate of insurance no less than five (5) days after the award of the contract. The Commission reserves the right to cancel the contract if the Commission does not receive the said certificate in which event the contract shall be null and void.

**28. Workers Compensation**

Successful construction project Contractors shall be required to provide evidence of compliance with workers' compensation legislation applicable to the place of the work including payments due thereunder, prior to award of the contract. Every successful construction project Contractor shall be required to provide evidence of such compliance at the time of submitting its first progress claim, at the time of substantial performance of the Work, and prior to issuance of the Certificate of Completion.



---

## SECURITY REQUIREMENTS

---

### Security Requirements

The NCC complies with Treasury Board's *Policy on Government Security* and consequently, it will require that the contractor's personnel submit to a personal security screening process (Security Clearance Form TBS/SCT 330-60E). The NCC may also perform a credit check when the duties or tasks to be performed require it or in the event of a criminal record containing a charge/offence of a financial nature.

*Personal information associated with these clearances is retained in the following information bank: Personnel Security Screening \_ PSU 917.*

The NCC reserves the right to not award the Contract until such time as the contractor's personnel core employees have obtained the required level of security screening as identified by the NCC's Corporate Security. In this case the level of security required will be **Reliability\***

***\*For operation needs, with advice or assistance from NCC Corporate Security, the security level can be upgraded (Confidential, Secret or Top Secret) on the basis of the sensitivity of the information and assets that need to be accessed.***

### Additional information

As part of their personal screening, individuals may be required to provide evidence of their status as a Canadian citizen or permanent resident as well as any other information/documentation requested by the NCC's Corporate Security in order to complete the screening.

The NCC reserves the right to refuse access to personnel who fail to obtain the required level of security screening.

The NCC reserves the right to impose additional security measures with respect to this contract as the need arises.

When warranted by a Security threat and risk assessment (TRA) or any type of Security Assessment, physical security safeguards can be recommended by NCC Corporate Security to reflect changes in the threat environment or for operational purposes.

The NCC also reserves the right to request that the Contractor submit to a *Designated Organization Screening* and/or *Facility Security Clearance* – depending on the nature of the information it will be entrusted with.

### Company Security Representative

The contractor shall appoint one Company Security Representative (CSR) as well as one alternate (for companies who have more than five employees).

Selection criteria for the CSR and the alternate are the following:

- They must be employees of the contractor's firm;

---

## SECURITY REQUIREMENTS

---

- They must have a security clearance (the NCC will process the clearances once the individuals have been identified).

### Responsibilities of the Company Security Representative

The CSR's responsibilities are the following:

- Act as liaison between the NCC's Corporate Security and the contractor to ensure coordination;
- In collaboration with the NCC's Corporate Security, identify the contractor's personnel who will require access to NCC information/assets/sites **as well as any recurring subcontractors** (and their employees) who will require similar access and may not be supervised by the contractor at all times during such access. Ensure that accurate and complete Personnel Security Screening documentation is submitted to the NCC's Corporate Security for the employees/subcontractors who have been identified;
- Ensure that employees/subcontractors, upon notification of having been granted a Security status (**Reliability-Site Access-Secret**), sign the *Security Screening Certificate and Briefing Form* and return to the NCC's Corporate Security;
- Ensure that only persons who have been security screened to the appropriate level and who are on a "need-to-know basis" will have access to information and assets;
- Maintain a current list of security screened employees/subcontractors;
- Ensure proper safeguard of all information and assets, including any information/assets entrusted to subcontractors;
- If a Security incident or suspected breach of security occurs, prepare and submit to the NCC an occurrence report as soon as possible.

### Access to site

Unless otherwise indicated, all visits to "secure" sites (official residences) shall be coordinated with, and approved through NCC Corporate Security.

### References

[Security of Information Act](#)

[Access to Information Act](#)

[Privacy Act](#)

[Policy on Government Security](#)

## Occupational Health and Safety Requirements

### 1. General

- 1.1** In this Contract “OHS” means “occupational health and safety”.
- 1.2** With respect to the work to be performed under the Contract, the Contractor covenants and agrees to perform at, and to enforce conformity with, a standard equivalent to or greater than the best practices prevailing in the construction industry at that time.
- 1.3** The Contractor acknowledges that, to the extent that the following matters may be affected by conduct of the work, it is responsible for the:
- 1.3.1 health and safety of persons on site;
  - 1.3.2 safety of property on site;
  - 1.3.3 protection of persons adjacent to the site; and,
  - 1.3.4 protection of the environment.
- 1.4** Without limiting the generality of section 1.3, the Contractor acknowledges that it is required to, and covenants and agrees to, comply and to enforce compliance with all laws or regulations that may be applicable to the conduct of the work including, without limitation:
- (a) the provisions of the *Occupational Health and Safety Act* of Ontario and all regulations, policies or directives issued thereunder for work performed in Ontario;
  - (b) *La Loi sur la santé et la sécurité du travail* of Québec and all regulations, policies or directives issued thereunder for work performed in Québec;
  - (c) Applicable provisions of the *Canada Labour Code, Part II*;
  - (d) Employment standards legislation in the province(s) in which any part of the work is performed; and
  - (e) Any policies or directives issued by the NCC in respect of the subject matter of the contract.
- The NCC will present any such policies or directives referred to in paragraph (e) to the Contractor in written form by not later than the pre-construction meeting. The Contractor is obliged to ensure that the relevant policies and directives have been communicated to and acknowledged by all its employees and that they will be complied with. The NCC reserves the right to require the Contractor to produce evidence satisfactory to the NCC acting reasonably that the Contractor has discharged the foregoing obligations.
- 1.5** By entering into the Contract with the NCC, the Contractor represents and warrants to the NCC that it has informed itself of and is knowledgeable about the obligations imposed by the legislation referred to in 1.4. above.
- 1.6** For purposes of the relevant provincial OHS legislative regime the Contractor acknowledges and agrees that it is the “Constructor” and covenants to discharge and accept all liability for the performance of the obligations of the “Constructor” in respect of the work provided for in the Contract. Notwithstanding a determination by the relevant authority having jurisdiction that the NCC is the “Constructor” in the event of a dispute between the Contractor and the NCC, the

- Contractor acknowledges and agrees that the Contractor shall be financially responsible for the implementation of protective measures necessary to fulfill the obligations of the “Constructor”.
- 1.7** As between the NCC and the Contractor, the NCC’s decision as to whether the Contractor is discharging its obligations in respect of OHS issues shall be definitive. Without limiting the generality of the foregoing, in the event of any dispute with respect to instructions given by the NCC’s designated representative, the Contractor may note such dispute, but must nevertheless forthwith comply with any such instructions.
- 1.8** The Contractor hereby indemnifies and agrees to hold harmless the NCC, its agents and employees, from and against any and all claims, demands, losses, costs (including legal fees on a full indemnity basis), damages, actions, suits or proceedings (hereinafter collectively referred to as “claims”) by third parties that arise out of or are attributable to the Contractor’s errors or omissions in the performance of the Contract. Without limiting the generality of the foregoing, this indemnification extends to any claims related to any violation of any statute or regulation relating to OHS matters.
- 1.9** The NCC shall provide the contractor:
- 1.9.1 a written description of every known and foreseeable health and safety hazard to which persons employed in the performance of the work may be exposed because of the nature of the site;
  - 1.9.2 a list of any prescribed materials, equipment, devices and clothing necessary because of the nature of the site;
  - 1.9.3 with written information indicating the prescribed circumstances and manner to use all prescribed materials, equipment, devices and clothing listed pursuant to 1.9.2; and,
  - 1.9.4 with a copy of any NCC policies and procedures that may be applicable in relation to the work site.
- 1.10** Without limiting the generality of 1.9, prior to the commencement of the work by the contractor, the contractor shall, at the contractor’s expense:
- 1.10.1 take all reasonable care to ensure that all persons employed in the performance of the work or granted access to the work or its site are informed of any health and safety hazard described pursuant to 1.9.1;
  - 1.10.2 provide all persons employed in the performance of the work or granted access to the work or its site with prescribed materials, equipment, devices and clothing listed pursuant to 1.9.2;
  - 1.10.3 take all reasonable care to ensure that all persons employed in the performance of the work or granted access to the work or its site are familiar with the prescribed circumstances and manner all prescribed materials, equipment, devices and clothing listed pursuant to 1.9.2; and
  - 1.10.4 take all reasonable care to ensure that all persons employed in the performance of the work or granted access to the work or its site are familiar with policies and procedures referred to in 1.9.4.

## **2. Qualifications of Personnel**

- 2.1** By entering into this agreement the contractor represents and warrants that it has the requisite experience, training, formal certification and equipment to enable it to discharge the obligations enumerated in sections 1.3, 1.4, 1.5 and 1.6 above.
- 2.2** The Contractor represents and warrants that supervisory personnel employed by the Contractor in respect of performance of any part of the work have the requisite experience, authority, training, formal certification and equipment to ensure that the obligations enumerated in sections 1.3, 1.4, 1.5 and 1.6 above are discharged and agrees to deliver such evidence as may be required by the NCC from time to time to verify same.

## **3. Certification**

- 3.1** After receiving notification that its bid has been retained and prior to and as a condition of contract award, the Contractor covenants and agrees to deliver a Worker's Compensation Clearance Certificate. Where the duration of the project is greater than sixty days, the Contractor covenants and agrees to deliver up-dated certificates at least every 60 days. In the event of a failure by the Contractor to deliver up-dated certificates, the NCC shall be entitled to immediately terminate the contract without notice and without incurring any liability to the Contractor.
- 3.2** After receiving notification that its bid has been retained and prior to and as a condition of contract award, the Contractor covenants and agrees to deliver historical information on its injury experience including any pertinent Worker's Compensation Experience Reports. Such historical information shall report data for the previous three years.

## **4. Plans Policies and Procedures**

- 4.1** After receiving notification that its bid has been retained and prior to and as a condition of contract award, the Contractor covenants and agrees to deliver for the review and approval of the NCC:

- (a) A copy of the contractor's OHS policy;
- (b) A safety program and plan specific to the work to be performed pursuant to the Contract which plan shall include a risk assessment and analysis, a description of safe working methods, injury and incident reporting protocols, regular periodic reporting on compliance with OHS obligations including any policies, practices and procedures otherwise provided for herein, and a site-specific contingency and emergency response plan; and
- (c) Health and safety training records of personnel and alternates responsible for OHS issues on site.

The Contractor covenants and agrees to deliver the necessary material safety data sheets for the review and approval of the NCC prior to entering the site to perform work related to the relevant material.

Approval by the NCC does not amend the provisions of the Contract with respect to the allocation of liability for discharging or failing to discharge OHS obligations. Such liability remains with the Contractor notwithstanding the granting of such approval.

- 4.2** The Contractor acknowledges and agrees that prior to commencement of work it must attend a pre-construction briefing at which any special or additional practices and procedures to be followed in completing the work are to be established. Without limiting the provisions of section 1.4(e) above, the representatives of the Contractor attending the briefing will be required to deliver

a signed acknowledgement that the practices and procedures set out in the pre-construction briefing have been understood and will be complied with.

- 4.3** At any time and from time to time during the performance of the work, the NCC shall have the right to audit the manner in which the Contractor is discharging its OHS obligations and to determine whether the project specification and/or OHS policies, practices and procedures are being complied with. In the event that the audit discloses any failure by the Contractor to discharge such OHS obligations, the NCC shall be entitled to forthwith rectify at the Contractor's expense any such deficiency and the NCC shall have the further right to immediately terminate the contract without notice and without incurring any liability to the Contractor.
- 4.4** The Contractor covenants and agrees to conform with all requirements of the Workplace Hazardous Materials Information System.
- 4.5** The Contractor acknowledges and agrees that where required by any law or regulation applicable to the performance of the work it must establish and maintain a project health and safety committee. The contractor further acknowledges and agrees that it must enable staff to attend all relevant safety meetings, and that the cost of same, including costs attributable to standing down equipment is included in its bid price and is not independently recoverable.
- 4.6** Where required by the relevant provincial regulatory regime, the Contractor acknowledges and agrees that it is responsible for delivery of notice of the project to the relevant regulatory authority, and for the performance of any other administrative activity required to meet the obligations imposed in the pertinent provincial regulatory regime.
- 4.7 (Optional depending on hazard or scope of project).** The contractor covenants and agrees that it shall employ and assign to the work, a competent OHS professional as Health and Safety Coordinator that must:
- (a) have a minimum two (2) years' site-related working experience specific to activities associated with.(identify specific subject matter)
  - (b) have basic working knowledge of specified occupational safety and health regulations,
  - (c) be responsible for completing health and safety training session and ensuring that personnel not successfully completing the required training are not permitted to enter the site to perform the Work,
  - (d) be responsible for implementing, enforcing daily and monitoring the site-specific Health and Safety Plan, and
  - (e) be on site during execution of the Work.

The parties acknowledge that in lieu of employing an OHS professional, the Contractor may provide same by sub-contracting for such services.

- 4.8** Upon completion of the work the Contractor covenants and agrees to participate with the NCC in a post performance interview to evaluate the performance of the Contractor in respect of the OHS obligations under the contract. Without limiting the generality of the foregoing, the interview will identify areas of compliance and non-compliance in terms of:
- (a) actual performance of the work;
  - (b) reporting or procedural requirements;

(c) resolution of deficiencies.

The contractor acknowledges and agrees that the results of the post-completion interview may be relied upon by the NCC in evaluating bids subsequently submitted by the Contractor on other NCC projects.

Supplier No. / N° du fournisseur
----------------------------------

New supplier / Nouveau fournisseur       Update / Mise à jour

**SUPPLIER-DIRECT DEPOSIT PAYMENT AND TAX INFORMATION FORM  
FOURNISSEUR-FORMULAIRE DE PAIEMENT PAR DÉPÔT DIRECT ET RENSEIGNEMENTS AUX FINS DE L'IMPÔT**

For NCC use only / À l'usage de la CCN seulement

**PART 'A' - IDENTIFICATION / PARTIE 'A' - IDENTIFICATION**

Legal name of entity or individual / Nom légal de l'entité ou du particulier	Operating name of entity or individual (if different from Legal Name) / Nom commercial de l'entité ou du particulier (s'il diffère du nom légal)		
Former Public Servant in receipt of a PSSA Pension / Ancien fonctionnaire qui reçoit une pension en vertu de la LPPF		<input type="checkbox"/> Yes / Oui	<input type="checkbox"/> No / Non
An entity, incorporated or sole proprietorship, which was created by a Former Public Servant in receipt of a PSSA pension or a partnership made of former public servants in receipt of PSSA pension or where the affected individual has a controlling or major interest in the entity. / Une entité, constituée en société ou à propriétaire unique, créée par un ancien fonctionnaire touchant une pension en vertu de la LPPF, ou un partenariat formé d'anciens fonctionnaires touchant une pension en vertu de la LPPF, où les entités dans lesquelles ils détiennent le contrôle ou un intérêt majoritaire.		<input type="checkbox"/> Yes / Oui	<input type="checkbox"/> No / Non
Address / Adresse	Telephone No. / N° de téléphone :	Fax No. / N° de télécopieur :	
Postal code / Code postal	( )	( )	

**PART 'B' - STATUS OF SUPPLIER / PARTIE 'B' - STATUT DU FOURNISSEUR**

**IMPORTANT : CHOOSE ONLY ONE OF THE FOLLOWING/CHOISIR SEULEMENT UNE DES OPTIONS SUIVANTES:**

(1) Sole proprietor / Propriétaire unique <input type="checkbox"/>	If sole proprietor, provide: / Si propriétaire unique, indiquez :	Last Name / Nom de famille	First name / Prénom	Initial / Initiale
(2) Partnership / Société de personnes <input type="checkbox"/>	(3) Corporation / Société <input type="checkbox"/>			
Business No. (BN) / N° de l'entreprise (NE) -	<b>OR / OU</b>	SIN / NAS -		
GST/HST / TPS et TVH	QST / TVQ (Québec)			
Number / Numéro : _____	Number / Numéro : _____			
Not registered / non inscrit <input type="checkbox"/>	Not registered / non inscrit <input type="checkbox"/>			
Type of contract / Genre de contrat	Contract for services only / Contrat de services seulement <input type="checkbox"/>			
	Contract for mixed goods & services / Contrat de biens et services <input type="checkbox"/>		Contract for goods only / Contrat de biens seulement <input type="checkbox"/>	
Type of goods and/or services offered / Genre de biens et / ou services rendus :				

**PART 'C' - FINANCIAL INSTITUTION / PARTIE 'C' - RENSEIGNEMENTS SUR L'INSTITUTION FINANCIÈRE**

**Please send a void cheque with this form / Veuillez, s.v.p., envoyer un spécimen de chèque avec ce formulaire**

Branch Number / N° de la succursale	Institution No. / N° de l'institution :	Account No. / N° de compte :
Institution name / Nom de l'institution :	Address / Adresse :	
	Postal Code / Code postal :	

**PART 'D' - DIRECT DEPOSIT PAYMENT NOTIFICATION / PARTIE 'D' - AVIS DE PAIEMENT PAR DÉPÔT DIRECT**

E-mail address / Adresse courriel :

**PART 'E' - EMAIL ADDRESS TO SEND CONTRACTS / PARTIE 'E' - ADRESSE COURRIEL POUR ENVOYER LES CONTRATS**

E-mail address / Adresse courriel :

**PART 'F' - CERTIFICATION / PARTIE 'F' - CERTIFICATION**

I certify that I have examined the information provided above and it is correct and complete, and fully discloses the identification of this supplier.	Je déclare avoir examiné les renseignements susmentionnés et j'atteste qu'ils sont exacts et constituent une description complète, claire et véridique de l'identité de ce fournisseur.		
Where the supplier identified on this form completes part C, he hereby requests and authorizes the National Capital Commission to directly deposit into the bank account identified in part C, all amounts payable to the supplier.	Lorsque le fournisseur indiqué sur ce formulaire remplit la partie C, par la présente, il demande et autorise la Commission de la capitale nationale à déposer directement dans le compte bancaire indiqué à la partie C, tous les montants qui lui sont dus.		
Name of authorized person / Nom de la personne autorisée	Title / Titre	Signature	Date
Telephone number of contact person / Numéro de téléphone de la personne ressource : ( )			

**IMPORTANT**

Please fill in and return to the National Capital Commission with one of your business cheque unsigned and marked « VOID » (for verification purposes).

Veillez remplir ce formulaire et le retourner à la Commission de la capitale nationale avec un spécimen de chèque de votre entreprise non signé et portant la mention « ANNULÉ » (à des fins de vérification).

Mail or fax to: Procurement Services  
National Capital Commission  
202-40 Elgin Street  
Ottawa, ON K1P 1C7 Fax: (613) 239-5007

Poster ou télécopier à : Services de l'approvisionnement  
Commission de la capitale nationale  
40, rue Elgin, pièce 202  
Ottawa (Ontario) K1P 1C7 Télécopieur : (613) 239-5007



**SUPPLIER – DIRECT DEPOSIT PAYMENT AND TAX INFORMATION FORM**

**FOURNISSEUR – FORMULAIRE DE PAIEMENT PAR DÉPÔT DIRECT ET RENSEIGNEMENTS AUX FINS DE L'IMPÔT**

**Supplier Tax Information**

Pursuant to paragraph 221(1) (d) of the *Income Tax Act*, NCC must declare form T-1204, contractual payments of government for services, all payments made to suppliers during the calendar year in accordance to related service contracts (including contracts for mixed goods and services).

The paragraph 237(1) of the *Income Tax Act* and the article 235 of the Income Tax Regulations require the supplier to provide all necessary information below to the organization who prepares the fiscal information forms.

Questions: Sylvie Monette, Accounts Payable Supervisor  
(613) 239-5678 ext. 5156 or [sylvie.monette@ncc-ccn.ca](mailto:sylvie.monette@ncc-ccn.ca)

**Direct deposit payment information**

All amounts payable by NCC to the supplier will be deposited directly into the account you identified in part C. A NCC payment advice notice will also be sent to you by e-mail detailing the particularities of the payment to the address identified in part D.

Until we process your completed form, we will still pay you by check.

You must notify the NCC of any changes to your financial institution, branch or account number. You will then have to complete a new form.

The account you identified has to hold Canadian funds at a financial institution in Canada.

**The advantages of direct deposit payment**

Direct deposit payment is a convenient, dependable, safe and timesaving way to receive your invoice payment. Direct deposit payment is completely confidential.

There are fewer risks of direct deposit payment being lost, stolen, or damaged as may happen with cheques.

Funds made by direct deposit payment will be available in your bank account on the same day that we would have mailed your cheque.

**Renseignements sur les fournisseurs aux fins de l'impôt**

En vertu de l'alinéa 221(1) (d) de la *Loi de l'impôt sur le revenu*, la CCN est tenu de déclarer, à l'aide du formulaire T-1204, Paiements contractuels de services du gouvernement, tous paiements versés aux fournisseurs pendant une année civile en vertu de marchés de services pertinents (y compris les marchés composés à la fois de biens et de services).

Le paragraphe 237 (1) de la *Loi de l'impôt sur le revenu* et l'article 235 du Règlement de l'impôt sur le revenu obligent les fournisseurs à fournir toutes les informations demandées ci-dessous à l'organisme qui prépare les formulaires de renseignements fiscaux.

Questions : Sylvie Monette, Superviseure aux comptes payable  
(613) 239-5678 poste 5156 ou [sylvie.monette@ncc-ccn.ca](mailto:sylvie.monette@ncc-ccn.ca)

**Renseignements sur le paiement par dépôt direct**

Tous les montants versés par la CCN au fournisseur seront déposés directement dans le compte identifié à la partie C. Un avis de paiement de la CCN détaillant les particularités du paiement par dépôt direct vous sera envoyé par courriel à l'adresse courriel identifiée à la partie D.

Nous continuerons à vous payer par chèque jusqu'à ce que nous ayons traité votre formulaire.

Vous devez aviser la CCN de tout changement d'institution financière, de succursale ou de numéro de compte. Vous devrez donc remplir un nouveau formulaire.

Le compte que vous désignez doit être un compte en monnaie canadienne, détenu dans une institution financière au Canada.

**Avantages du paiement par dépôt direct**

Le paiement par dépôt direct est une méthode pratique, fiable et sécuritaire, qui permet de gagner du temps dans la réception de vos paiements de factures. Le paiement par dépôt direct est entièrement confidentiel.

Avec les paiements par dépôt direct, il y a moins de risques de perte, de vol ou de dommage, comme cela peut se produire dans le cas des chèques.

Les paiements effectués par paiement par dépôt direct sont versés dans votre compte le jour même où nous aurions posté votre chèque.

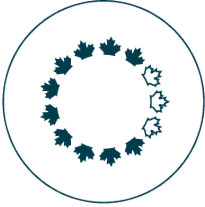

**NATIONAL CAPITAL COMMISSION  
COMMISSION DE LA CAPITALE NATIONALE**

**REQUEST FOR STANDING OFFER AGREEMENT (RFSO)**

**Asphalt Patch Work and Repairs  
Parkways, Pathways and Parking Lots**

**for the**

**NATIONAL CAPITAL COMMISSION**

**Terms of Reference  
May 2017**

---

Asphalt Patch Work and Repairs – Parkways, Pathways & Parking Lots for the NCC

---

**Table of Contents**

**INVITATION**..... 3  
**INTRODUCTION**..... 3  
**SUMMARY OF WORK**..... 3  
**TIME OF COMPLETION**..... 5  
**DEFINITIONS** ..... 5  
**OCCUPATIONAL HEALTH AND SAFETY** ..... 5  
**CONTRACT TERM AND SCHEDULE OF PAYMENT** ..... 6  
**COMPENSATION FOR A CALL-UP PURCHASE ORDER WITH AN UPSET  
LIMIT** ..... 6  
**CHANGES TO SPECIFICATIONS**..... 6  
**RESPECT OF PROPERTY**..... 7  
**DAMAGES** ..... 7  
**TRAFFIC CONTROL**..... 7  
**NCC’S RESPONSIBILITIES**..... 7  
**PROPOSAL REQUIREMENTS**..... 8  
**EVALUATION AND BASIS OF AWARD** ..... 9  
**APPENDIX 2 – Technical Proposal** ..... 10  
**APPENDIX 3 — RATES SCHEDULE AND UNIT PRICES** ..... 12

---

Asphalt Patch Work and Repairs – Parkways, Pathways & Parking Lots for the NCC

---

## **INVITATION**

The National Capital Commission (NCC) is calling for Proposals from Contractors to provide Asphalt patch work and repairs services on an “as and when requested basis” in the Ontario side of Canada’s Capital Region.

The successful contractor(s) will be required to perform work in Ottawa, Ontario.

More than one Standing Offer Agreement (SOA) may be awarded as a result of this request for proposal. The resulting SOA(s) will be from the date of award to November 30, 2019. Unit prices quoted will remain fixed for the duration of the SOA.

The maximum all-inclusive amount payable for any one purchase order (call-up) shall be \$75,000.00 CDN including all fees, disbursements, sub-consultant costs and all applicable taxes..

The NCC reserves the right to request quotations from all firms who obtained SOA’s and any firm that qualified under this request for proposal for any work that may be required, when the initial estimate of the work exceeds \$75,000.00 CDN all inclusive.

The estimated expenditure for all the resulting Standing Offer Agreements will be \$300,000.00 CDN. As operational requirements become more defined, the NCC reserves the right to increase the total estimated expenditure but in no circumstance will the total estimated expenditure be more than 10% of the initial total expenditure.

## **1- INTRODUCTION**

The National Capital Commission’s Ontario Urban Lands and Greenbelt Division (OUL/GB) is responsible for the maintenance of over 40 km of parkways and 180 km of pathways as well as numerous parking lots within the parks and parkways around the National Capital Region (Ottawa-Gatineau). Regular maintenance and repair work are often required on its assets. The objective of this RSOA is to allow the NCC to obtain on an as needed and requested basis an asphalt contractor for minor rehabilitation, repairs and maintenance.

## **2- SUMMARY OF WORK**

- The Contractor shall comply with all federal, provincial and municipal applicable laws and regulations. The Contractor must also have obtained, at his costs, all the licenses and permits required in respect of the execution of the work in the province of Ontario.

---

Asphalt Patch Work and Repairs – Parkway, Pathways & Parking Lots for the NCC

---

- The NCC reserves the right to reject any tender if the Contractor does not have all the necessary permits and licenses for the execution of the work
- The Contractor must supply necessary labour and equipment to perform asphalt repair work with hot mix asphalt.
- The Contractor must supply the required material in order to carry out the work.
- Work to be performed may consist in multiple small patch work in multiple areas spanning full length of parkways and/or pathways.

**Asphalt and Materials**

- Provide asphalt, bonding agent and other materials as per specifications in Appendix 1 – Hot Mix Asphalt Paving.
- **Costs of materials must be included as part of the all inclusive rates quoted in Appendix 3.**

**Cutting and Patching**

- Make cuts with clean, true, smooth edges.
- Where new work connects with existing and where existing work is altered, cut, patch and make good to match existing work.

See attached cycling map for general potential work areas of OUL/GB portfolio, (excludes Quebec Urban Lands and Gatineau Park in Québec).

---

Asphalt Patch Work and Repairs – Parkways, Pathways & Parking Lots for the NCC

---

### **3- TIME OF COMPLETION**

- .1 The work to be performed will be between April and November each year.
- .2 The Contractor must inform NCC a minimum of 48 hours in advance when work will be performed in order to avoid potential conflicts with events and other work which may be occurring at the site.
- .3 During the term of this agreement, the Contractor must respond to emergency calls and be on site within twenty-four (24) hours following the receipt of a call-up purchase order.
- .4 All other regular service requests must be accomplished as per agreed schedule of work.

### **4- DEFINITIONS**

Whenever the following words appear in the Terms of Reference, they will have the meaning indicated henceforth:

NCC: National Capital Commission which is a Crown Corporation of the Canadian Federal Government created by the National Capital Act.

Contractor: One or more companies that will be contracted by the NCC.

OUL/GB: Ontario Urban Land and Greenbelt division within the NCC's Capital Stewardship (CS) branch.

### **5- OCCUPATIONAL HEALTH AND SAFETY**

When performing work, the Contractor must comply with all the federal, provincial and municipal laws and regulations regarding occupational health and safety. When federal, provincial or municipal provisions treat the same subject matter differently; the Contractor shall comply with the strictest provision. The Contractor shall be responsible for all costs resulting from the Contractor's compliance with the federal, provincial and municipal laws and regulations regarding occupational health and safety (including occupational health and safety in the construction industry). Refer to separate annex for further details.

---

Asphalt Patch Work and Repairs – Parkways, Pathways & Parking Lots for the NCC

---

**6- SOA TERM AND SCHEDULE OF PAYMENT**

- .1 **The term of the SOA(s) will be from the date of award to November 30, 2019.**
- .2 It is the contractor's responsibility to notify the Project Manager when work performed under the SOA is completed. All work will be reviewed, in-situ, by the Project Manager before payment can be authorised.
- .3 The Contractor will have the right to receive payments within 30 days after the project manager has approved the installations and indicated that in fact the invoice is authentic and exact, that the Contractor has performed the said work during the mentioned period and has observed the terms of the contract. The Commission is a Crown Corporation subject to the Goods and Services Tax (GST) and the Provincial Sales Tax (OHST). The Contractor is required to indicate separately, with the request for payment, the amount of GST and OHST, to the extent applicable, that the Commission will pay. These amounts will be paid to the Contractor who will be required to make the appropriate remittances to Revenue Canada and the respective provincial governments. All invoices are to make reference to the **Commission File Number xxxxxx (call up Purchase Order (PO-#))** and be forwarded to Accounts Payable, by email at [payables@ncc-ccn.ca](mailto:payables@ncc-ccn.ca). To ensure prompt payment, please prepare your invoice in accordance with the unit and/or lump sum price(s) quoted. Errors in invoicing can cause delay of payment. Submit your invoice to [payables@ncc-ccn.ca](mailto:payables@ncc-ccn.ca) and clearly indicate the call up PO number.

**7- COMPENSATION FOR A CALL-UP PURCHASE ORDER WITH AN UPSET LIMIT**

Payment will be based on the amount of square meters of asphalt repaired or replaced and type of intervention as per work order.

**8- CHANGES TO SPECIFICATIONS**

The Contractor must inform the NCC when work is not performed as per the Appendix 1 – Hot Mix Asphalt Paving. The NCC reserves the right to accept or refuse the changes proposed by the Contractor.

---

Asphalt Patch Work and Repairs – Parkways, Pathways & Parking Lots for the NCC

---

## **9- RESPECT OF PROPERTY**

The Contractor will be held responsible for any damage done to the equipment and material used and belonging to the NCC or of another party when performing work. Driving and parking on areas other than designated hard surfaces must be kept to an absolute minimum, and only when there is no other alternative.

## **10- DAMAGES**

All damages done to plants, landscaped areas, roads, trails and structures during the execution of asphalt work by the mandate of this contract will be the responsibility of the Contractor and shall be restored to their initial condition or replaced, and thus to the satisfaction of the NCC.

## **11- TRAFFIC CONTROL**

All traffic control at work sites shall be the responsibility of the Contractor. The Contractor shall comply with the provincial uniform traffic control standards (Ontario Traffic Control Manual, Book 7 – Temporary Conditions). Only Staff trained and certified in the aforementioned traffic control standards shall be used by the Contractor.

Safety vests shall be worn when possible conflict between vehicles, employees and the general public exists. All signs used for traffic control shall be bilingual.

## **12- NCC'S RESPONSIBILITIES**

Provide the Contractor with all required specifications of the work.



---

Asphalt Patch Work and Repairs – Parkways, Pathways & Parking Lots for the NCC

---

### 13- PROPOSAL REQUIREMENTS

#### **Technical Proposal (Appendix 2)**

Proponents shall submit their technical proposal using Appendix 2, and submit one (1) original signed fee proposal using Appendix 3. The fee proposal shall be signed and submitted in a separately sealed and clearly marked envelope.

- Contactor must **have a minimum of five (5) years of experience** in order to undertake and execute various work described in these terms of reference.
- Contractors shall provide a brief description of its company experience; and
- Contractor shall provide a list of three (3) similar projects undertaken including elaborating on traffic control procedures and provide a reference for each project by completing Appendix 2.

#### **Financial Proposal (Appendix 3)**

Proponents shall provide hourly rates for standard and emergency services in Appendix 3 – Fee Proposal for work in Ontario.

- **Standard Service:** pricing is for work orders with a list of predetermined areas, to be scheduled, coordinated and performed within a reasonable agreed upon time frame.
- **Emergency Service:** pricing is used for emergency demands and compulsory work; work to be done within 24hrs. Submit price for work in Appendix 3 based on a 24 hour emergency responses.

Estimated quantities indicated in Appendix 3 are for bid evaluation purposes only.

---

Asphalt Patch Work and Repairs – Parkways, Pathways & Parking Lots for the NCC

---

**14- RATED REQUIREMENTS, EVALUATION CRITERIA AND BASIS OF AWARD**

## Rated Requirements

- Company experience 40 points.
- Projects and references 60 points.

## Evaluation criteria

- Company experience:
  - number of years in business
  - experience carrying out asphalt repair and installation projects
  - ability to respond to emergency requests
- Projects and references:
  - variety of projects
  - size and complexity of projects
  - traffic control in high volume situations

In order to qualify, Contractors must obtain a minimum of 60 points out of a possible 100 points. Price envelopes of qualified contractors only will be opened.

Proposals with 60 points and over are deemed qualified and their price envelopes opened. The bidder who submits the lowest total price (regular + emergency services) may be awarded a Standing Offer Agreement.

More than one (1) Standing Offer Agreement may be awarded as a result of this tender call. The NCC intends to award a minimum one (1) SOA for work in the province of Ontario.

Lowest or any tender is not necessarily accepted.

All taxes are extra to the unit prices quoted.

Should there be a tied bid, the NCC will award to the company that offers the most experience and industry specific certifications (proof required).

Asphalt Patch Work and Repairs – Parkways, Pathways & Parking Lots for the NCC

**APPENDIX 2 – Technical Proposal**

Contractors must have a minimum of five (5) years’ experience in providing asphalt patch work and repairs services as described in these terms of reference.

**Describe your company’s experience**

(years in operation, type of work, number of employees, type of equipment, etc.).

---



---



---



---



---



---

List three (3) projects over the last 5 years similar in nature to the scope of work indicated in these terms of reference, describing procedures for traffic control and provide a reference for each.

Projects	Traffic Control Procedures	References
		Company name:
		Contract person:
		Telephone no.:
		Company name
		Contract person:
		Telephone no.:
		Company name:
		Contract person:
		Telephone no.:

Company Name: \_\_\_\_\_

Signature of authorized person: \_\_\_\_\_

Date: \_\_\_\_\_

---

Asphalt Patch Work and Repairs – Parkways, Pathways & Parking Lots for the NCC

---

**APPENDIX 3 — RATES SCHEDULE AND UNIT PRICES (in Canadian dollars)**  
 (To be submitted in a separate sealed envelope)

- Estimated quantities for evaluation purposes only.
- **Unit Prices quoted in this table are for work to be performed in ONTARIO**

Item	Description	STANDARD SERVICES IN ONTARIO				EMERGENCY SERVICES IN ONTARIO			
		Estimated Quantities		Unit Price/m <sup>2</sup> (excl. taxes)	Total	Estimated Quantities		Unit Price/m <sup>2</sup> (excl. taxes)	Total
1a	Cut and remove or grind (to minimum of 50mm) damaged sections of asphalt. <i>For areas greater than 100m<sup>2</sup>.</i> Asphalt surface to original grade.	450 m <sup>2</sup>	X	\$ _____ / m <sup>2</sup>	= \$ _____	50 m <sup>2</sup>	X	\$ _____ /m <sup>2</sup>	= \$ _____
1b	Cut and remove or grind (to minimum of 50mm) damaged sections of asphalt. <i>For areas smaller than 100m<sup>2</sup>.</i> Asphalt surface to original grade.	180 m <sup>2</sup>	X	\$ _____ / m <sup>2</sup>	= \$ _____	20 m <sup>2</sup>	X	\$ _____ /m <sup>2</sup>	= \$ _____
2	Cut and remove damaged sections of asphalt for pathways. Remove roots or objects, rebuild base and asphalt to original grade as per drawings 110.1 and 110.2.	180 m <sup>2</sup>	X	\$ _____ / m <sup>2</sup>	= \$ _____	20 m <sup>2</sup>	X	\$ _____ /m <sup>2</sup>	= \$ _____
3	Cut and remove damaged sections of asphalt for pathways. Remove roots or objects, rebuild base and asphalt to original grade as per drawing "Pathway Repair Leda Clay".	180 m <sup>2</sup>	X	\$ _____ / m <sup>2</sup>	= \$ _____	20 m <sup>2</sup>	X	\$ _____ /m <sup>2</sup>	= \$ _____

Asphalt Patch Work and Repairs – Parkways, Pathways & Parking Lots for the NCC

4	Supply and install asphalt for overlay 50mm thick and potholes. <i>For areas smaller than 100m<sup>2</sup></i>	180 m <sup>2</sup>	X	\$ _____ / m <sup>2</sup>	=	\$ _____		20 m <sup>2</sup>	X	\$ _____ /m <sup>2</sup>	=	\$ _____
5	Supply and install asphalt for overlay of 50mm thick. <i>For areas greater than 100m<sup>2</sup></i>	720 m <sup>2</sup>	X	\$ _____ / m <sup>2</sup>	=	\$ _____		80 m <sup>2</sup>	X	\$ _____ /m <sup>2</sup>	=	\$ _____
6	Catch Basin 600mm X 600mm minor height adjustment.	5 units	X	\$ _____ /unit	=	\$ _____		2 units	X	\$ _____ /unit	=	\$ _____

Prices quoted are all-inclusive  
All taxes are extra to the unit  
prices quoted.

Total for Regular Service \$ \_\_\_\_\_

Total for Emergency Service \$ \_\_\_\_\_

**GRAND TOTAL** (regular + emergency) for work in the Province of Ontario \$ \_\_\_\_\_

Company Name: \_\_\_\_\_

Signature of authorized person: \_\_\_\_\_ Date: \_\_\_\_\_

PART 1 - GENERAL

1.1 References

- .1 American Society for Testing and Materials (ASTM)
  - .1 ASTM C 88-99A, Test Method for Soundness of Aggregates by Use of Sodium Sulphate or Magnesium Sulphate.
  - .2 ASTM C 117-95, Test Method for Materials Finer Than 0.75 mm in Mineral Aggregates by Washing.
  - .3 ASTM C 123-98, Test Method for Lightweight Pieces in Aggregate.
  - .4 ASTM C 127-88(1993e1), Test Method for Specific Gravity and Absorption of Coarse Aggregate.
  - .5 ASTM C 131-96, Test Method for Resistance to Degradation of Small-Size Course Aggregate by Abrasions and Impact in the Los Angeles Machine.
  - .6 ASTM C 136-96A, Method for Sieve Analysis of Fine and Coarse Aggregates.
  - .7 ASTM D 698-91(1998), Test Method for Laboratory Compaction Characteristics of Soil Using Standard Effort 600 kN-m/m<sup>3</sup>.
  - .8 ASTM D 1557-91(1998), Test Method for Laboratory Compaction Characteristics of Soil Using Modified Effort 2,700 kN-m/m<sup>3</sup>.
  - .9 ASTM D 1559-89, Test Method for Resistance of Plastic Flow of Bituminous Mixtures Using Marshall Apparatus.
  - .10 ASTM D 1883-99, Testing Method for CBR (California Bearing Ratio) of Laboratory Compacted Soils.
  - .11 ASTM D 2419-95, Test Method for Sand Equivalent Value of Soils and Fine Aggregate.
  - .12 ASTM D 4318-98, Test Method for Liquid Limit, Plastic Limit, and Plasticity Index of Soils.
  - .13 ASTM D 4791-99, Test Method for Flat or Elongated Particles in Course Aggregate.
  - .14 ASTM D698-00A, Testing Method for Laboratory Compaction Characteristics of soil using Standard Effort (12,400 ft-lb/ft<sup>3</sup>)(600 KN-m/m<sup>3</sup>
  - . 15 ASTM D2922-01, Standard Testing

Methods for density of Soil and Soil-Aggregate in place by Nuclear Methods (Shallow depth.

- .2 Canadian General Standards Board (CGSB)
  - .1 CAN/CGSB-8.1-88, Sieves Testing, Woven Wire, Inch Series.
  - .2 CAN/CGSB-16.2-M89, Emulsified Asphalts, Anionic Type, for Road Purposes.
  - .3 CAN/CGSB-16.3-M90, Asphalts for Road Purposes.
- .3 Canadian Standards Association (CSA)
  - .1 CSA-A5-98, Portland Cement.
  - .2 CSA-A23.1/A23.2-00, Concrete Materials and Methods of Concrete Construction/Methods of Test for Concrete.
  - .3 CSA-A23.4-00/A251-00, Precast Concrete - Materials and Construction/Qualification Code for Architectural and Structural Precast Concrete Products.
  - .4 CSA A231.2-95, Precast Concrete Pavers.
  - .5 CSA G30.5-M1983(R1998), Welded Steel Wire Fabric Concrete Reinforcement.
  - .6 CSA G40.20/G40.21-98, General Requirements for Rolled or Welded Structural Quality Steel/Structural Quality Steel.
  - .7 CSA 231.1-99, Precast Concrete Paving Slabs.
  - .8 CAN/CGSB-8-2-M88, Sieves Testing, Woven Wire, Metric

1.2 Waste Management and Disposal

- .1 Separate and recycle waste materials in accordance with Section 01355 - Waste Management.
- .2 Deposit packaging materials in appropriate container on site for recycling or reuse.
- .3 Avoid using landfill waste disposal procedures when recycling facilities are available.
- .4 Collect and separate plastic, paper



packaging and corrugated cardboard.

- .5 Dispose of corrugated cardboard, polystyrene and plastic packaging material in appropriate on-site bin.

PART 2 - PRODUCTS

2.1 Materials

- .1 Hot Mix Asphalt Paving
  - .1 Hot mix asphalt paving to meet requirements of Ontario Provincial Standard Specification for HL3 (OPSS 310.07 (1993) and:
    - .1 Asphalt Cement: to CAN/CGSB-16.3.
    - .2 Reclaimed Asphalt Pavement: Crushed and screen to 100% passing 50 mm screen before mixing.
    - .3 Asphalt Concrete Aggregates:
      - .1 Crush or screen stone, gravel and sand. Compacted granular material to 98% maximum density in accordance with ASTM D 698 and ASTM D 1557 maximum 150 mm lifts.
      - .2 Gradations to be within limits specified when tested to ASTM C 136 and ASTM C 117. Sieve sizes to CAN/CGSB-8.1.
      - .3 Sand equivalent: to ASTM D 2419. Minimum 50.
      - .4 Magnesium Sulphate Soundness: to ASTM C 88. Maximum % loss by weight: coarse aggregate 12, fine aggregate 16.
      - .5 Los Angeles Degradation: to ASTM C 131. Maximum % loss by weight: coarse aggregate 35.
      - .6 Absorption: to ASTM C 127. Maximum % by weight: coarse aggregate 1.75.
      - .7 Lightweight particles: to ASTM C 123. Maximum % by mass, with less than 1.95 relative density 1.5.
      - .8 Flat and elongated particles: to ASTM D 4791. Maximum % by weight: coarse aggregate 15.

APPENDIX 1

.4 Mineral filler: finely ground particles of limestone, Portland cement or other non-plastic mineral matter.

.5 Tack coat: to CAN/CGSB-16.2, grade SS-1.

.6 Compact hot asphalt mix to obtain 95% standard density in accordance with Marshall specimens in accordance with ASTM D 1559.

2.2 System  
Performance

- .1 As required to achieve specified performance criteria; functionally compatible with adjacent materials and components, and at a minimum meet the requirements and relevant standards listed under References.
- .2 Performance will provide appropriately finished hot mix asphalt paving for spaces required by the contract that are appropriate for anticipated usage and traffic.

2.3 Source Quality  
Control

- .1 Installer/Supplier Qualifications:
  - .1 Submit a letter of competence issued by manufacturer indicating a minimum 5 years experience related to installation of product.
  - .2 Applicators shall have a minimum of 5 years experience in successful installation of systems specified in this section.
  - .3 Ensure precast manufacturer is certified to CSA A251.

PART 3 - EXECUTION

3.1 Manufacturer's  
Instructions

- .1 Compliance: Comply with manufacturer's written data, including product technical bulletins, product catalogue installation instructions, product carton installation instructions, and data sheet.

3.2 Installation

- .1 Install hot mix asphalt paving in accordance with manufacturer's written instructions, product data, reference standards and authorities having

jurisdiction.

3.3 Cleaning

- .1 Clean installed products in accordance to manufacturer's recommendation.

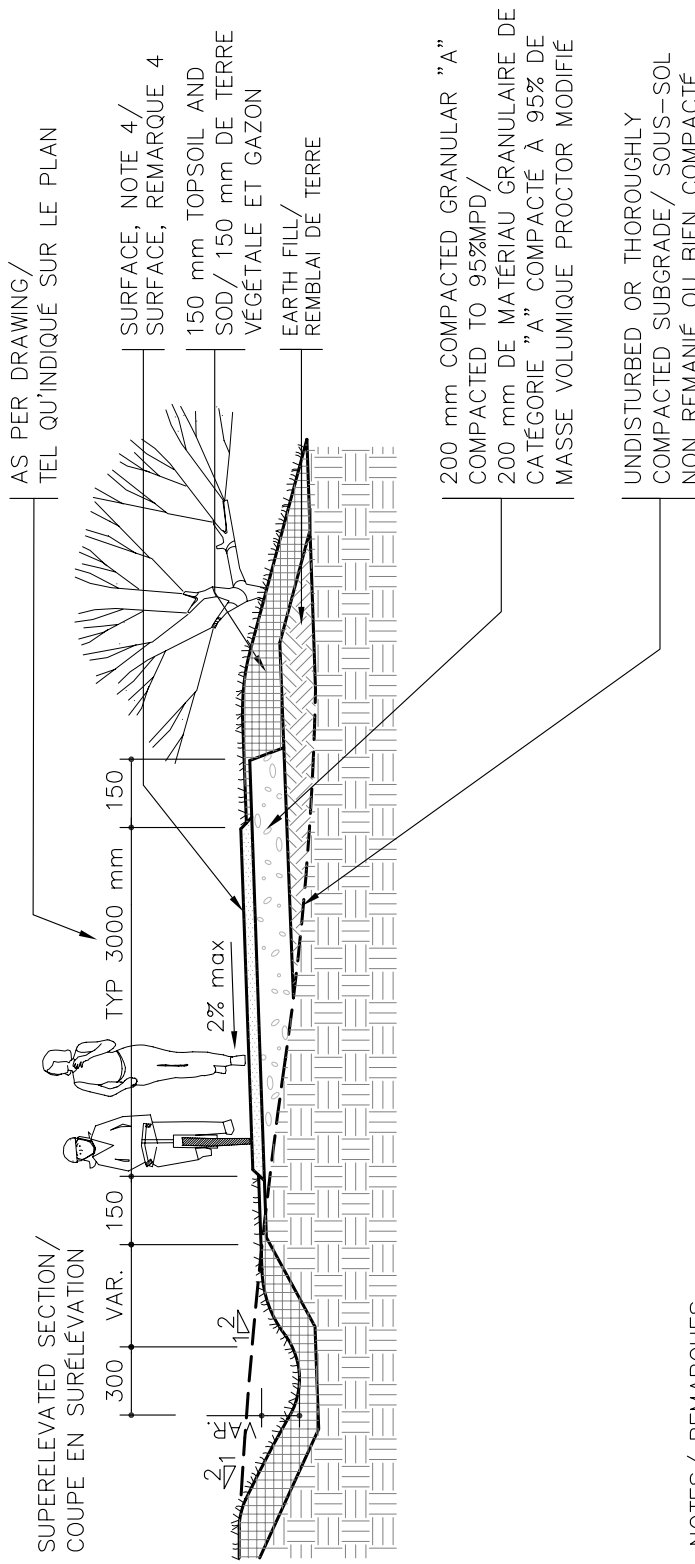
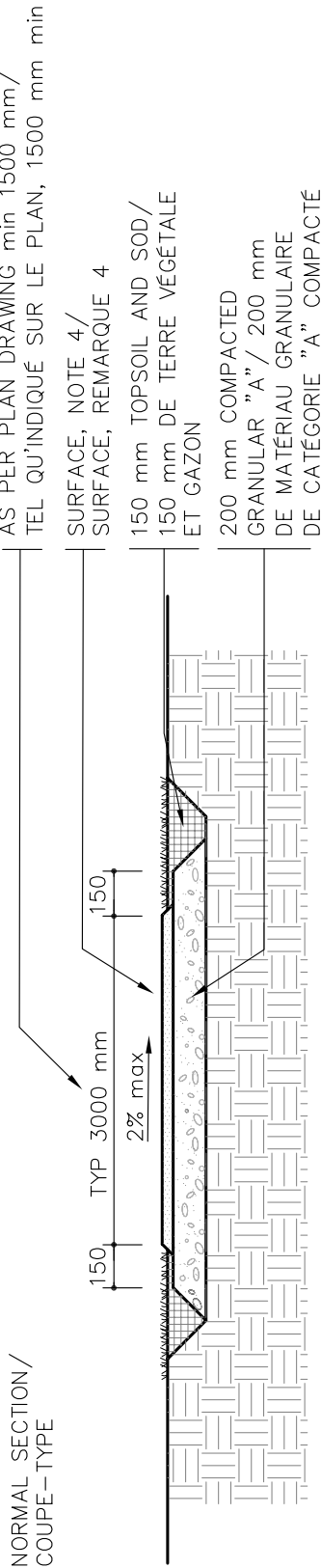

- NOTES/ REMARQUES
- REMOVE EXISTING TOPSOIL FOR WIDTH OF NEW EMBANKMENT/  
ENLEVER LA TERRE VÉGÉTALE EXISTANTE À LA LARGEUR DU NOUVEAU REMBLAI
  - CROSS SLOPE IN DIRECTION OF NORMAL SURFACE DRAINAGE EXCEPT IN SUPERELEVATED SECTIONS/  
PENTE TRANSVERSALE DANS LE SENS DU DRAINAGE NATUREL DU TERRAIN SAUF POUR LES COUPES SURÉLEVÉES
  - SUPERELEVATION REQUIRED/ SURÉLEVATION REQUISE:
    - ON CURVES LESS THAN R = 21000 mm AND FOR SLOPES UP TO 3%/  
DANS LES COURBES DE MOINS DE R = 21000 mm ET LES PENTES JUSQU'À 3%
    - ON CURVES LESS THAN R = 46000 mm AND FOR SLOPES OVER 3%/  
DANS LES COURBES DE MOINS DE R = 46000 mm ET LES PENTES DE PLUS DE 3%
  - 50 mm HL3 ASPHALT OR 50 mm STABILIZED STONEDUST WITH CALCIUM CHLORIDE/ 50 mm D'ASPHALTE HL3 OU 50 mm DE POUSSIÈRE DE PIERRE STABILISÉE AVEC CHLORURE DE CALCIUM
  - SURFACE TREATMENT AS PER/ TRAITEMENT DE SURFACE TEL QU'INDIQUÉ AU CSA B651-04, SECTION 3.3.1



Canada

Design and Construction Division  
Division design et construction

project projet	PROJECT PROJET
drawing dessin	RECREATIONAL PATHWAY-MULTIUSE SENTIER RÉCRÉATIF-POLYVALENT

scale échelle	NTS
date	MAR/MAR 2008
NCC project no. no. du projet de la CCN	PROJECT NO.

approved by approuvé par	LA
designed by conçu par	
drawn by dessiné par	
sheet no. no. de la feuille	110.1

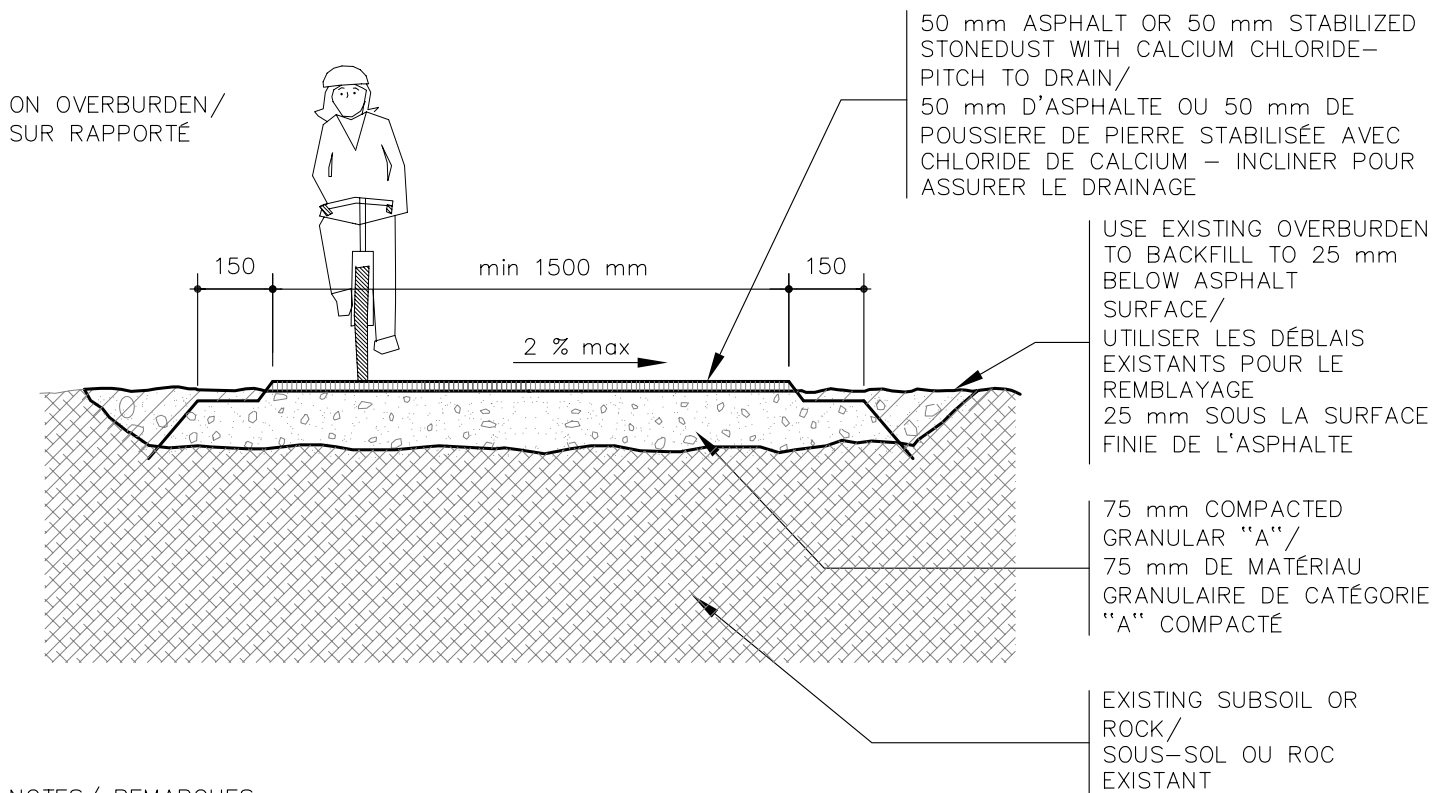
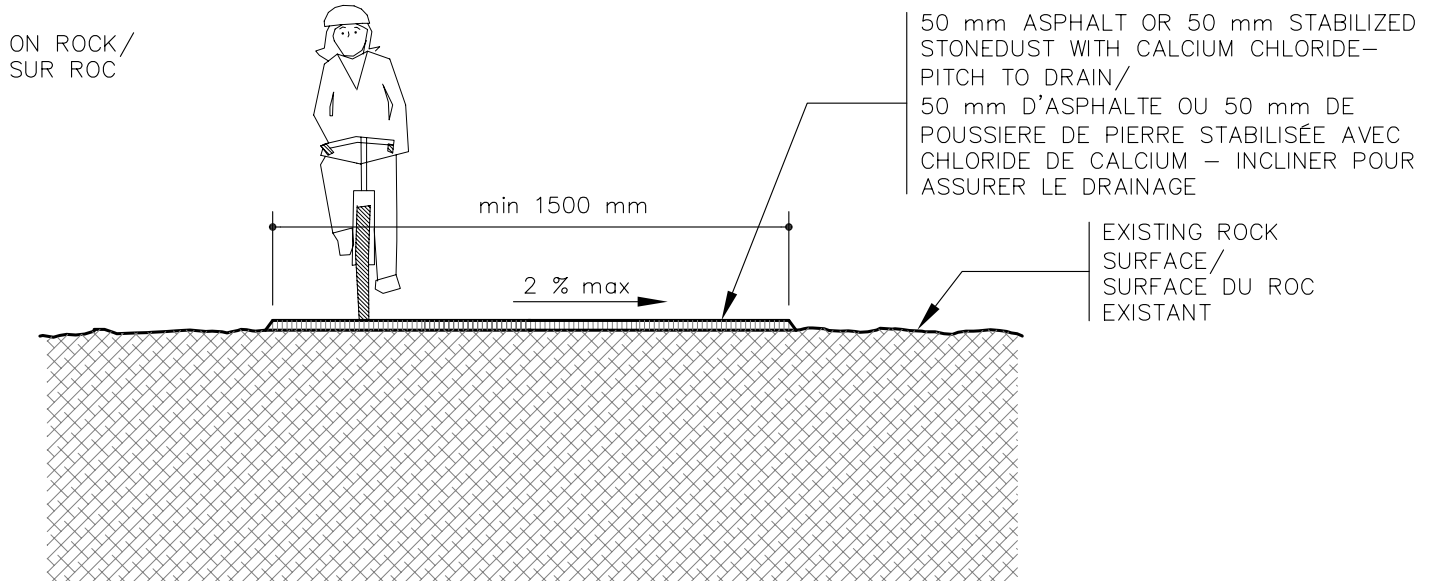

NOTES / REMARQUES

FILL ALL SIGNIFICANT HOLES OR DEPRESSIONS WITH GRANULAR "A". WHERE POSSIBLE REMOVE OVERBURDEN OR TOPSOIL TO A MINIMUM DEPTH OF 150 mm /  
REMPLEZ TOUS LES TROUS IMPORTANTS OU LES DÉPRESSIONS AVEC UN MATÉRIAU GRANULAIRE DE CATÉGORIE "A". LÀ OÙ C'EST POSSIBLE, ENLEVER LE MORT-TERRAIN OU LA TERRE VÉGÉTALE À UNE PROFONDEUR DE 150 mm MINIMUM



Design and Construction Division  
Division design et construction

approved by /  
approuvé par LA

designed by /  
conçu par

drawn by /  
dessiné par

project /  
projet PROJECT /  
PROJET

scale /  
échelle NTS

date JAN/JAN 2008

drawing /  
dessin PATHWAY ON ROCK OR OVERBURDEN /  
SENTIER SUR ROC OU MORT-TERRAIN

NCC project no. /  
no. du projet de la CCN PROJECT NO.

sheet no. /  
no. de la feuille 110.2

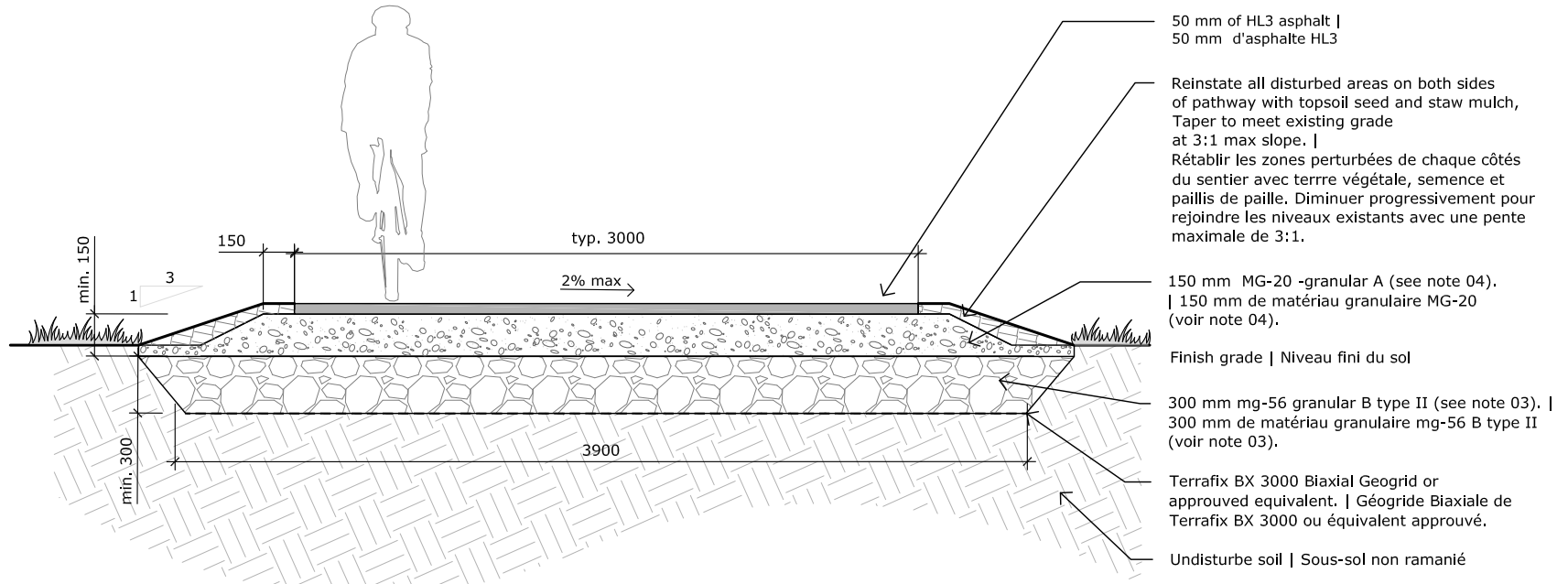

NOTES | REMARQUES

1. Excavate to design subgrade level. Ensure subgrade is fully exposed, Remove all existing granular material, Subgrade to be smooth and level | Excaver jusqu'au niveau proposé. Protéger le sous-sol contre toutes perturbations. Le sous-sol doit être lisse et de niveau.
02. Place biaxial BX3000 geogrid on subgrade. Deploy (i.e. unroll) geogrid in direction of pathway axis/alignment. Geogrid is to be laid/placed so that it is a single layer (no joints) across the width of the pathway. Pull geogrid so that, in transverse direction, it is taut and free of bulges. | Placer le géogride biaxial BX3000 sur le sous-sol. Déployer (dérouler) le géogride dans la direction de l'alignement / l'axe du sentier. Le géogride doit être étalé/posé de manière à ce qu'il ne forme qu'une seule couche (sans joint) à travers la largeur du sentier. Tirer serrer le géogride de manière à ce qu'il soit tendu et exempt de bosse ou renflements en direction transversale.
03. Place mg 56 (granular B type II) and compact to at least 95% of its standard Proctor maximum dry density | Placer le matériau mg 56 de type II et compacter à un minimum de 95% de Proctor modifié
04. Place mg 20 (granular A) and compact to at least 95% of its standard Proctor maximum dry density | Placer le matériau mg-20 et compacter à un minimum de 95% de Proctor modifié
05. Place 50mm of asphaltic concrete and compact in accordance with the specifications. Slope surface 2% | Placer 50mm d'asphalte et compacter selon les indications des devis.



Design and Construction Division Division design et construction	
project projet	PROJECT PROJET
drawing dessin	DRAWING DESSIN

scale échelle	SCALE
date	DATE
NCC project no. no. du projet de la CCN	PROJECT_NO

approved by approuvé par	APPROVED_BY
designed by conçu par	DESIGN_BY
drawn by dessiné par	DRAWN_BY
sheet no. no. de la feuille	NO