

ITEM	QTY	MFR	DESCRIPTION	PART NO.
1	1	RITTAL	ENCLOSURE, 997mm X 1805mm X 405mm (W X H X D), SINGLE DOOR C/W REAR DETACHABLE PANEL, MOUNT PLATE	8084.500
2	1	RITTAL	TS SIDE PANELS, 1800 X 400mm, PACKAGE OF 2	8184.235
3	1	RITTAL	FLEX-BLOCK CORNER PIECES BASE/PLINTH SYSTEM, FIBREGLASS-REINFORCED PLASTIC	8200.000
4	1	RITTAL	FLEX-BLOCK TRIM PANELS, FOR 1000mm X 200mm (D X H), SOLID	8200.010
5	1	RITTAL	FLEX-BLOCK TRIM PANELS, FOR 400mm X 200mm (D X H), SOLID	8200.400
6	1	RITTAL	"SHEET STEEL WIRING PLAN POCKETS, 855mm X 210mm (W X H), 90mm DEEP"	4124.000
7	2	RITTAL	GROUND BUS, COPPER, 20 GROUNDING CLIPS, 2 ISOLATORS	7113.000
8				
9	1	BY NRCAN	LAMACOID LABEL, 250mm X 150mm (W X H), ENGRAVED WITH 15mm HIGH TEXT AS INDICATED, BLACK LETTERING ON WHITE	
10	18	AUTOMATION DIRECT	SOLE TEMPERATURE CONTROLLER, 1/16 DIN, OUT1 PULSE, OUT2 SPST, 100-240VAC	5L-8484-VR
11	6	AUTOMATION DIRECT	78 SERIES RELAY, SPDT, 15A, 120 VAC COIL	781-1C-120A
12	6	AUTOMATION DIRECT	AUTOMATION DIRECT, 78 SERIES RELAY SOCKET	781-1C-SKT
13	12	FUJII	FUJII, DUO SERIES SC-E CONTACTOR, 3 POLE, 110 VAC COIL, 32A RESISTIVE	SC-E05-110VAC
14	6	AUTOMATION DIRECT	SOLID ST RELAY 10A SPST VDC INPUT N.O. 24-280 VAC ZERO CROSS DIN MOUNT	AD-SSR810-DC282
15	11	AUTOMATION DIRECT	SOLID ST RELAY 30A SPST VDC INPUT N.O. 24-280 VAC DIN MOUNT	AD-SSR230-22-DC2
16	18	EATON	22MM TWO-POSITION SELECTOR SWITCH, (1) NO CONTACT	GCX1300
17	18	EATON	LEGEND PLATE "OFF-ON"	E22NS42
18	18	EATON	22MM INDICATOR LIGHT "GREEN" LED, 120VDC/VAC	ECQ2052-127L
19				
20	1	CARLO GAVAZZI	3 PHASE SOLID STATE RELAY, 25A, 4-32VDC CONTROL, 600V	RZ3A60D25
21	1	CARLO GAVAZZI	HEATSINK WITH DIN RAIL ADAPTER ASSEMBLY FOR 3-PHASE SSRs	RHS300
22				
23	1	BUSSMANN	CH SERIES MODULAR FUSE HOLDER, CHM 10X38 AND MIDGET, 600V/30A, 3-POLE, 18-4 AWG	CHM30DU
24	13	BUSSMANN	CH SERIES MODULAR FUSE HOLDER, CHM 10X38 AND MIDGET, 600V/30A, 2-POLE, 18-4 AWG	CHM2DU
25	6	BUSSMANN	CH SERIES MODULAR FUSE HOLDER, CHM 10X38 AND MIDGET, 600V/30A, 1-POLE, 18-4 AWG	CHM1DU
26	1	BUSSMANN	COM-BUS BAR, 3PH, 600V CUTTABLE 100A, 57 PINS, WITHOUT ENDCAP (19) 3PH HOLDERS	BB3P100M57
27	2	BUSSMANN	3 PHASE BUSBAR ENDCAP	ECAP3MP
28	3	BUSSMANN	35sq-mm, FEEDER TERMINAL FOR 3PH BUSBAR (115A, 1000VAC/DC)	PWR35MM
29	18	BUSSMANN	SPARE CONTACT SAFETY PROTECTION COVER	FSCVR
30	8	BUSSMANN	13/32" X 1-1/2" 600VAC FAST-ACTING SUPPLEMENTAL FUSES, 2.5A	KLM-2-1/2
31	4	BUSSMANN	13/32" X 1-1/2" 600VAC FAST-ACTING SUPPLEMENTAL FUSES, 5A	KLM-5
32	2	BUSSMANN	13/32" X 1-1/2" 600VAC FAST-ACTING SUPPLEMENTAL FUSES, 6A	KLM-6
33	2	BUSSMANN	13/32" X 1-1/2" 600VAC FAST-ACTING SUPPLEMENTAL FUSES, 7A	KLM-7
34	4	BUSSMANN	13/32" X 1-1/2" 600VAC FAST-ACTING SUPPLEMENTAL FUSES, 8A	KLM-8
35	3	BUSSMANN	13/32" X 1-1/2" 600VAC FAST-ACTING SUPPLEMENTAL FUSES, 9A	KLM-9
36	2	BUSSMANN	13/32" X 1-1/2" 600VAC FAST-ACTING SUPPLEMENTAL FUSES, 20A	KLM-20
37	8	BUSSMANN	13/32" X 1-1/2" 600VAC FAST-ACTING SUPPLEMENTAL FUSES, 30A	KLM-30
38				
39	28	ENTRELEC	STANDARD TERMINAL BLOCK, M 4/6, WITH TEST 2mm TEST SOCKET	115 217.14
40	20	ENTRELEC	FUSED TERMINAL BLOCKM4/8.SF	115 657.25
41		ENTRELEC	TERMINAL BLOCKS, M 6/8	115 118.11
42	1	ENTRELEC	END SECTION, M4/6	118 368.16
43	1	ENTRELEC	END SECTION, M4/8.SF	116 951.15
44	46	ENTRELEC	END STOP (ALL RAILS)	206 351.16
45		ENTRELEC	SEPARATOR END SECTION, RAIL MOUNT, SCF6	118 707.03
46	4.8m	ENTRELEC	ASSEMBLY RAIL, PR30 (TS 35/F6), DIN 3, 35mm, 2 meter	173 220.05
47	5	ENTRELEC	RAIL OFFSET MTG BRACKET, TS0441-SM6 40mm HIGH	101 655.06
48	8	ENTRELEC	RAIL OFFSET MTG BRACKET, TS0441-SM6 20mm HIGH	101 653.04
49	1	ENTRELEC	COMB-TYPE JUMPER BAR, PC6, 10 POLE, 35A, (M 4/6)	113 548.26
50	4	ENTRELEC	COMB-TYPE JUMPER BAR, PC81, 10 POLE, 35A, (M 4/8.SF)	173 523.11
51		ENTRELEC	COMB-TYPE JUMPER BAR, PCB1, 10 POLE, 50A, (M 6/8)	163 313.24
52		ENTRELEC	SHIELD CONNECTOR, CBM5, PKG OF 10	178 745.14
53	26	ENTRELEC	SM6 MTG BRACKET SCREWS	101 659.12
54		ENTRELEC	TERMINAL BLOCK BLANK MARKING TAGS, 6mm SPACING, 10X10 PER CARD, VERTICAL PRINTED NUMBER RANGE (SEE ATTACHMENT FOR CUSTOM LABELS)	233 000.01
55	4	EDISON	DIST BLK, FINGER SAFE, 175A, 1 IN/1 OUT, 1-POLE, UL LISTED, 1/PK	EPDB101
56				
57	2.6m	IBICO	WIRE DUCT, 4.0 x 4.0 IN., 4/PK, GRY, SLOTTED, 2M, WITH COVER	T1-4040G

ITEM	QTY	MFR	DESCRIPTION	PART NO.
58		IBICO	WIRE DUCT, 3.0 x 4.0 IN., 4/PK, GRY, SLOTTED, 2M, WITH COVER	T1-3040G
59	0.6m	IBICO	WIRE DUCT, 2.25 x 4.0 IN., 4/PK, GRY, SLOTTED, 2M, WITH COVER	T1-2240G
60		IBICO	WIRE DUCT, 1.5 x 4.0 IN., 4/PK, GRY, SLOTTED, 2M, WITH COVER	T1-1540G
61		IBICO	WIRE DUCT, 1.0 x 4.0 IN., 8/PK, GRY, SLOTTED, 2M, WITH COVER	T1-1040G
62	1	WEIDMULLER	9926 SERIES, SINGLE POLE, HYDRAULIC MAGNETIC, BRANCH RATED CIRCUIT BREAKER, 250VAC, 6.0A	9926251006
63	1	HAMMOND	PT SERIES CONTROL TRANSFORMER, 50/60 HZ, 500VA, 208V PRIMARY, 115V SECONDARY	PT500MLI
64	1	RITTAL	SK FILTER FAN, RAL 7035 115 V,	3239.110
65	1	RITTAL	SK OUTLET FILTER RAL 7035,	3239.200
66	18	AUTOMATION DIRECT	GROUND FAULT SENSOR, SPDT, DE-ENERGIZED AUTO RESET, 5/10/30 mA TRIP 120VAC	GFS30-D1C-120A-F

ITEM	QTY	MFR	DESCRIPTION	PART NO.
51		ENTRELEC	COMB-TYPE JUMPER BAR, PCB1, 10 POLE, 50A, (M 6/8)	163 313.24
52		ENTRELEC	SHIELD CONNECTOR, CBM5, PKG OF 10	178 745.14
53	26	ENTRELEC	SM6 MTG BRACKET SCREWS	101 659.12
54		ENTRELEC	TERMINAL BLOCK BLANK MARKING TAGS, 6mm SPACING, 10X10 PER CARD, VERTICAL PRINTED NUMBER RANGE (SEE ATTACHMENT FOR CUSTOM LABELS)	233 000.01
55	4	EDISON	DIST BLK, FINGER SAFE, 175A, 1 IN/1 OUT, 1-POLE, UL LISTED, 1/PK	EPDB101
56				
57	2.6m	IBICO	WIRE DUCT, 4.0 x 4.0 IN., 4/PK, GRY, SLOTTED, 2M, WITH COVER	T1-4040G

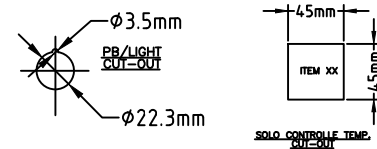

NO	REVISION DESCRIPTION	DATE (Y/M/D)	DRAWN	CKD	APPD
405	HEAT CONTROLLERS RS422 Comm WIRING				
404	HEATER CONTROL WIRING				
403	HEATERS 13 - 18 WIRING	1	ISSUE FOR TENDER	2017/03/24	RCM
402	HEATERS 07 - 12 WIRING	0	ISSUE FOR CLIENT REVIEW	2017/02/02	RCM
401	HEATERS 01 - 06 WIRING	No			

REFERENCE DRAWINGS

REVISION REGISTER

miriton
excellence by design
www.miriton.com

CLIENT: Natural Resources Canada / Ressources naturelles Canada
CANMET Energy Technology Center / Centre de la technologie de l'énergie de CANMET

DESIGNED: R. McNAIR
DRAWN: R. McNAIR
CHECKED:
APPROVED:
DATE: 2016/11/11
SCALE: NONE

PROJECT: NRCAN CANMET DCSG/HIPROX
TITLE: ELECTRICAL DCSG-HIPROX HEAT TRACING CABINET ASSY

USER	PROJECT	BUILDING	DRAWING	REV.
E	DCSG	BCC4	400	1

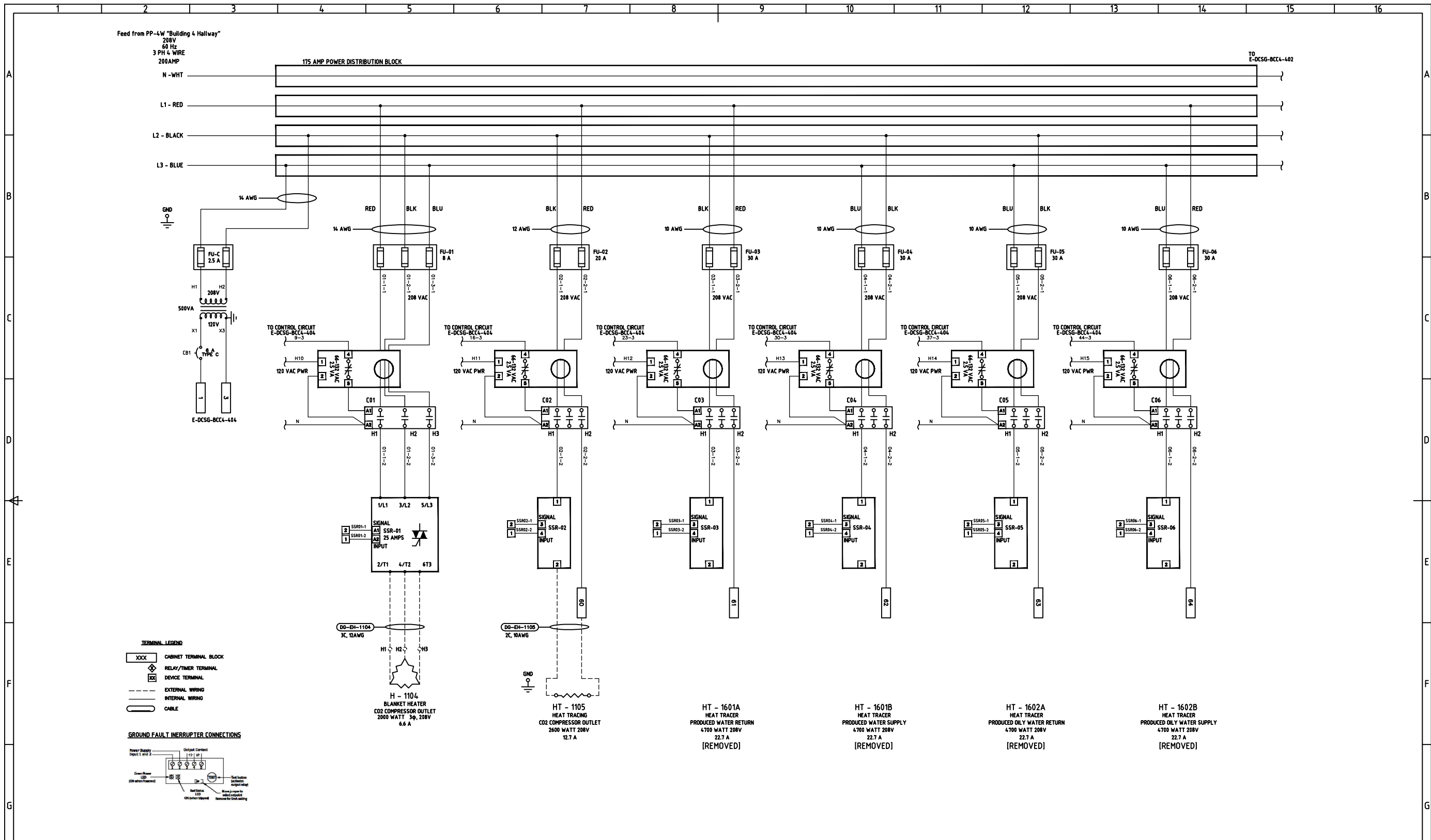

NO.	REVISION DESCRIPTION	DATE (Y/M/D)	DRAWN	CKD	APPD
404	HEATER CONTROL WIRING				
403	HEATERS 13 - 18 WIRING	2017/03/24	RCM		
402	HEATERS 07 - 12 WIRING	2017/02/02	RCM		
400	HEAT TRACING CABINET ASSEMBLY				

miniton
excellence by design
www.miniton.com

CLIENT: Natural Resources Canada / Ressources naturelles Canada
CANMET Energy Technology Center / Centre de la technologie de l'énergie de CANMET

DESIGNED R. McNAIR
DRAWN R. McNAIR
CHECKED
APPROVED
DATE 2016/11/11
SCALE NONE

PROJECT NRCAN CANMET DCSG/HIPROX				
TITLE ELECTRICAL DCSG-HIPROX HEATER/HEAT TRACING CABINET HEATERS 01 - 06 WIRING				
USER E	PROJECT DCSG	BUILDING BCC4	DRAWING 401	REV. 1

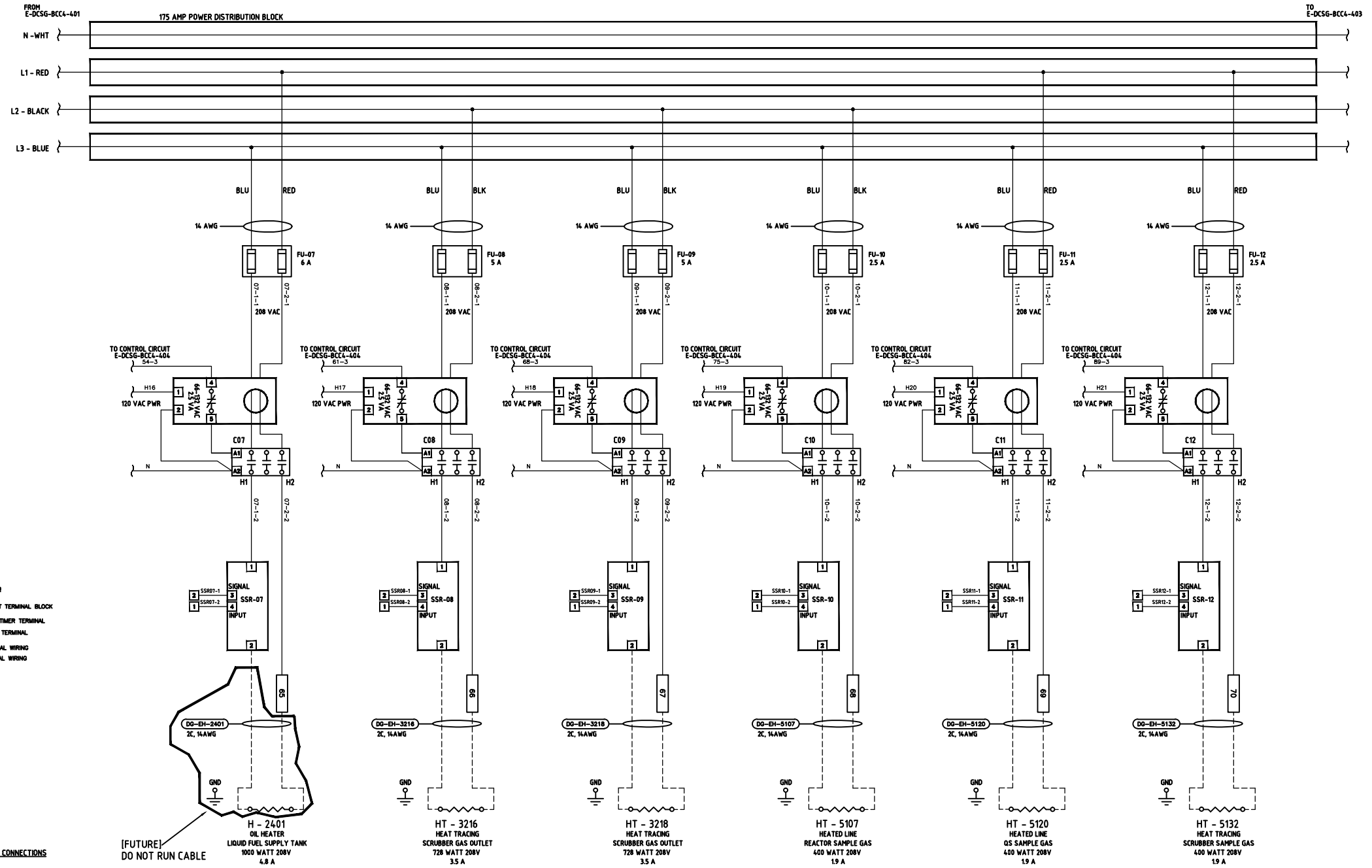

TERMINAL LEGEND

- XXX CABINET TERMINAL BLOCK
- ◇ RELAY/TIMER TERMINAL
- DEVICE TERMINAL
- - - EXTERNAL WIRING
- INTERNAL WIRING
- CABLE

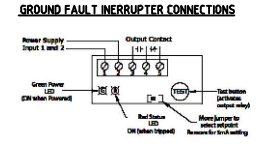

[FUTURE] DO NOT RUN CABLE

NO.	DESCRIPTION	REV.	DATE	BY	CHKD	APPD
404	HEATER CONTROL WIRING					
403	HEATERS 13 - 18 WIRING	1	2017/03/24	RCM		
401	HEATERS 01 - 06 WIRING	0	2017/02/02	RCM		
400	HEAT TRACING CABINET ASSEMBLY	No				

NO.	REVISION DESCRIPTION	DATE (Y/M/D)	DRAWN	CKD	APPD
1	ISSUE FOR TENDER	2017/03/24	RCM		
0	ISSUE FOR CLIENT REVIEW	2017/02/02	RCM		

excellence by design
www.miron.com

Natural Resources Canada
Ressources naturelles Canada
CANMET Energy Technology Center
Centre de la technologie de l'énergie de CANMET

DESIGNED
R. McNAIR

DRAWN
R. McNAIR

CHECKED

APPROVED

DATE
2016/11/11

SCALE
NONE

PROJECT
NRCAN CANMET DCSG/HIPROX

TITLE
ELECTRICAL
DCSG-HIPROX
HEATER/HEAT TRACING CABINET
HEATERS 07 - 12 WIRING

USER	PROJECT	BUILDING	DRAWING	REV.
E	DCSG	BCC4	402	1

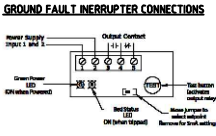
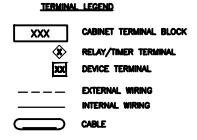
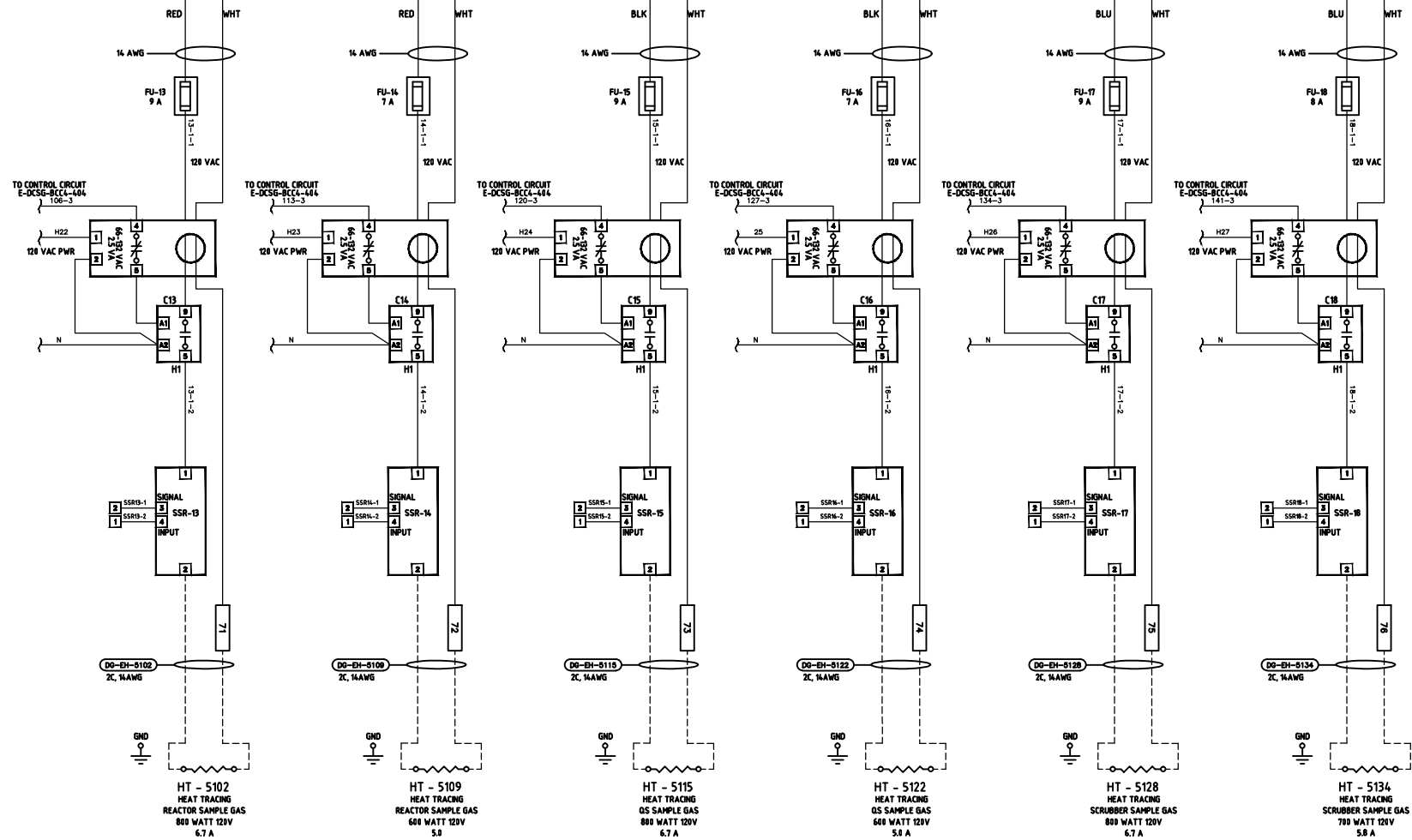
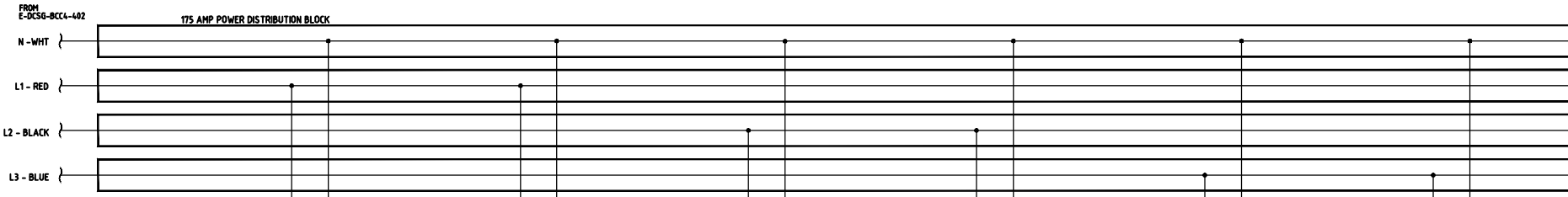

NO	DESCRIPTION	DATE	DRAWN	CKD	APPD
404	HEATER CONTROL WIRING	2017/03/24	RCM		
402	HEATERS 07 -12 WIRING	2017/02/02	RCM		
400	HEAT TRACING CABINET ASSEMBLY				

NO	REVISION DESCRIPTION	DATE (Y/M/D)	DRAWN	CKD	APPD
1	ISSUE FOR TENDER	2017/03/24	RCM		
0	ISSUE FOR CLIENT REVIEW	2017/02/02	RCM		

miniton
excellence by design
www.miniton.com

Canada
Natural Resources Canada
Ressources naturelles Canada
Centre de la technologie de l'énergie de CANMET

DESIGNED
R. McNAIR

DRAWN
R. McNAIR

CHECKED

APPROVED

DATE
2016/11/11

SCALE
NONE

PROJECT NRCAN CANMET DCSG/HIPROX
TITLE ELECTRICAL DCSG-HIPROX HEATER/HEAT TRACING CABINET HEATERS 13 - 18 WIRING
USER E
PROJECT DCSG
BUILDING BCC4
DRAWING 403
REV. 1

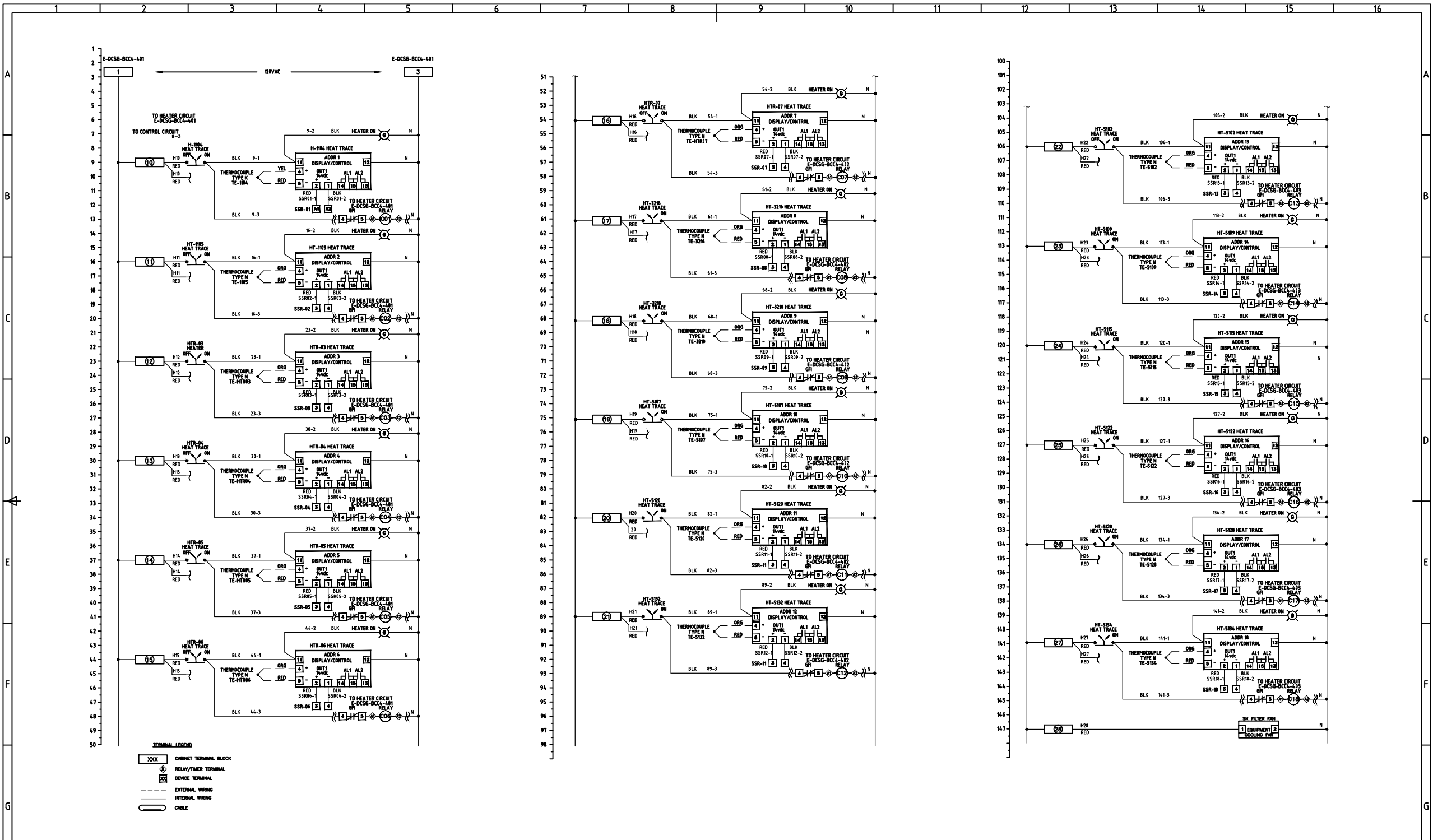

NO.	DESCRIPTION	DATE	BY	CHKD	APPD
405	HEAT CONTROLLERS RS422 Comm Wiring				
403	HEATERS 13 - 18 WIRING				
402	HEATERS 07 - 12 WIRING	2017/03/24	RCM		
401	HEATERS 01 - 06 WIRING	2017/02/02	RCM		
400	HEAT TRACING CABINET ASSEMBLY				

NO.	REVISION DESCRIPTION	DATE (Y/M/D)	DRAWN	CKD	APPD
1	ISSUE FOR TENDER	2017/03/24	RCM		
0	ISSUE FOR CLIENT REVIEW	2017/02/02	RCM		

miniton
excellence by design
www.miniton.com

CLIENT
Natural Resources Canada
CANMET Energy Technology Center

Canada
Ressources naturelles Canada
Centre de la technologie de l'énergie de CANMET

DESIGNED R. McNAIR	PROJECT NRCAN CANMET DCSG/HIPROX
DRAWN R. McNAIR	
CHECKED	
APPROVED	TITLE ELECTRICAL DCSG-HIPROX HEATER/HEAT TRACING CABINET HEATER CONTROL WIRING
DATE 2016/11/11	
SCALE NONE	USER E
	PROJECT DCSG
	BUILDING BCC4
	DRAWING 404
	REV. 1

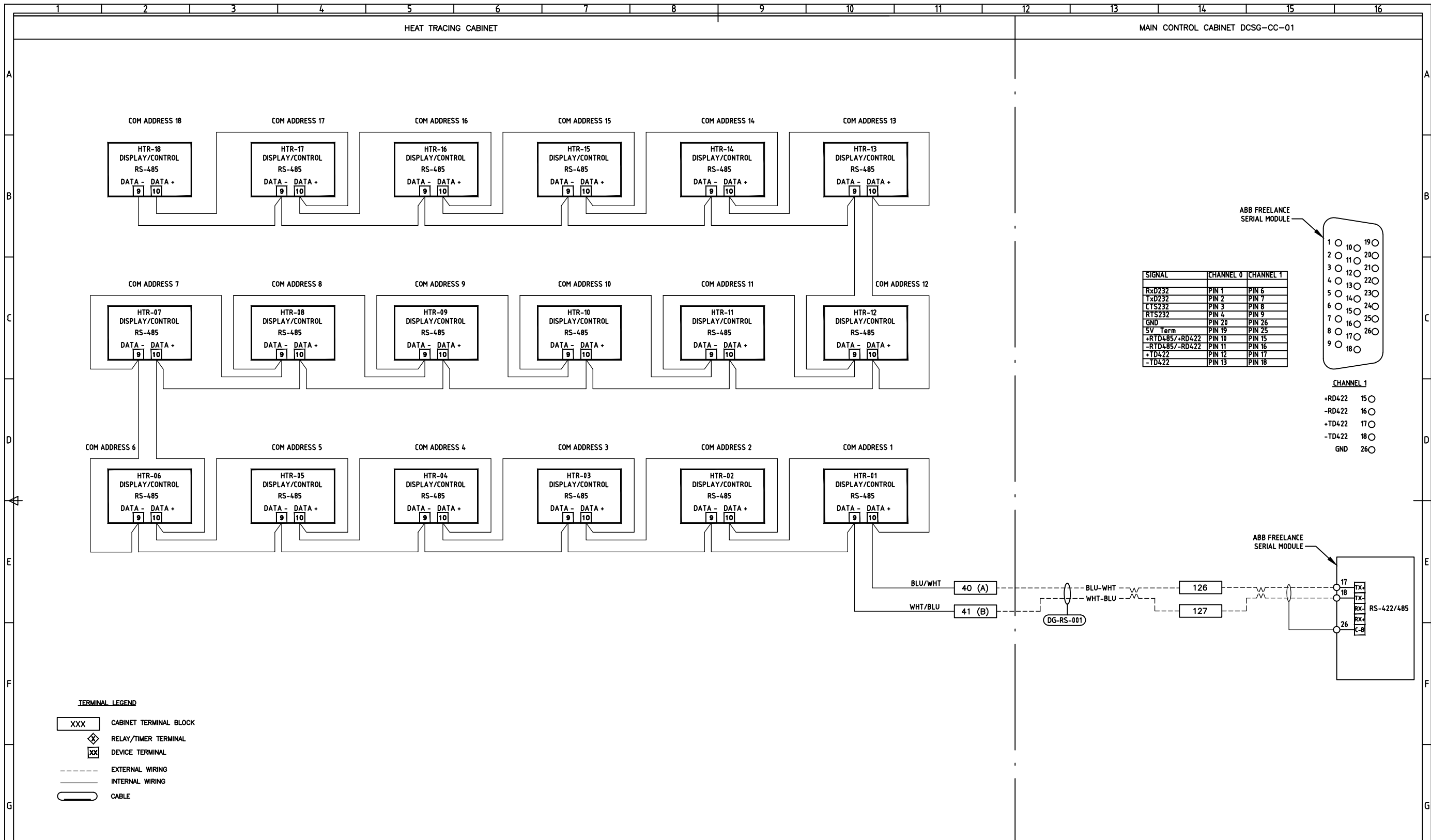

TERMINAL LEGEND

- XXX CABINET TERMINAL BLOCK
- ◇ RELAY/TIMER TERMINAL
- XX DEVICE TERMINAL
- EXTERNAL WIRING
- INTERNAL WIRING
- CABLE

100	MAIN CONTROL CABINET ASSY							
404	HEATER CONTROL Wiring							
403	HEATERS 13 - 18 WIRING							
402	HEATERS 07 - 12 WIRING	1	ISSUE FOR TENDER	2017/03/24	RCM			
401	HEATERS 01 - 06 WIRING	0	ISSUE FOR CLIENT REVIEW	2017/02/02	RCM			
400	HEAT TRACING CABINET ASSEMBLY	No						
REFERENCE DRAWINGS		REVISION REGISTER						
			REVISION DESCRIPTION	DATE (Y/M/D)	DRAWN	CKD	APPD	

excellence by design
www.miriton.com

Natural Resources Canada
Ressources naturelles Canada
CANMET Energy Technology Center
Centre de la technologie de l'énergie de CANMET

DESIGNED
R. McNAIR

DRAWN
R. McNAIR

CHECKED

APPROVED

DATE
2016/11/11

SCALE
NONE

PROJECT
NRCAN CANMET DCSG/HIPROX

TITLE
ELECTRICAL
DCSG-HIPROX
HEATER/HEAT TRACING CABINET
HEAT CONTROLLERS Comm WIRING

USER	PROJECT	BUILDING	DRAWING	REV.
E	DCSG	BCC4	405	1