



**RETURN BIDS TO:
RETOURNER LES SOUMISSIONS A:**

Courier To:

Bid Receiving/Réception des soumissions
Royal Canadian Mounted Police (RCMP)
Procurement & Contracting Services
Bid Receiving Unit,
c/o Commissionaires, F Division
6101 Dewdney Ave
Regina, SK S4P 3K7

Fax No. - N° de FAX:
(306) 780-5232

INVITATION TO TENDER

APPEL D'OFFRES

Tender to:

Royal Canadian Mounted Police

We hereby offer to sell to Her Majesty the Queen in right of Canada, in accordance with the terms and conditions set out herein, referred to herein or attached hereto, the goods, services and construction listed herein and on any attached sheets at the price(s) set out therefor.

Soumission aux: Gendarmerie royale du Canada

Nous offrons par la présente de vendre à Sa Majesté I Reine du chef du Canada, aux conditions énoncées ou incluses par référence dans la présente et aux annexes ci-jointes, les biens, services et construction énumérés ici sur toute feuille ci-annexée, au(x) prix indiqué(s).

Comments: - Commentaires :

THIS DOCUMENT CONTAINS A SECURITY REQUIREMENT

LE PRÉSENT DOCUMENT COMPORTE UNE EXIGENCE EN MATIÈRE DE SÉCURITÉ

Title – Sujet Janitorial Services – RCMP Prince Albert North District Building		Date May 30, 2017
Solicitation No. – N° de l'invitation M5000-18-0169/A		
Client Reference No. - No. De Référence du Client 201800169		
GETS Reference No. - No. De Référence du SEAG PW-17-00780872		
Solicitation Closes – L'invitation prend fin		
At / à :	2:00 PM	CST (Central Standard Time) HNC (Heure Normale du Centre)
On / le :	July 10, 2017	
Destination of Goods and Services – Destinations des biens et services Royal Canadian Mounted Police Prince Albert North District Building 2020 – 9 th Avenue West Prince Albert, SK S6V 6J7		
Instructions See herein — Voir aux présentes		
Address Inquiries to – Adresser toute demande de renseignements à Rachel Sookoo, Procurement Officer		
Telephone No. – No. de téléphone 639-625-3291	Facsimile No. – No. de télécopieur 306-780-5232	

COMPLETE BELOW IN FULL - REMPLISSEZ CI-DESSOUS EN ENTIER	
Vendor/Firm Name, Address and Representative – Raison sociale, adresse et représentant du fournisseur/de l'entrepreneur:	
GST or Business # - GST ou de nombre D'affaires nombre : _____	
If not applicable - Si non applicable Provide SIN # - Fournir le numéro d'assurance sociale (NAS) : _____	
Telephone No. – No. de téléphone	Facsimile No. – No. de télécopieur
E-Mail Address – adresse électronique :	
Name and title of person authorized to sign on behalf of Vendor/Firm (type or print) – Nom et titre de la personne autorisée à signer au nom du fournisseur/de l'entrepreneur (taper ou écrire en caractères d'imprimerie)	
Signature	Date



TABLE OF CONTENTS

PART 1 - GENERAL INFORMATION

- 1.1. Security Requirement
- 1.2. Statement of Work
- 1.3. Debriefings
- 1.4. Procurement Ombudsman
- 1.5. Trade Agreements

PART 2 - BIDDER INSTRUCTIONS

- 2.1. Standard Instructions, Clauses and Conditions
- 2.2. Submission of Bids
- 2.3. Enquiries - Bid Solicitation
- 2.4. Applicable Laws
- 2.5. Optional Site Visit
- 2.6. Promotion of Direct Deposit Initiative

PART 3 - BID PREPARATION INSTRUCTIONS

- 3.1. Bid Preparation Instructions

PART 4 - EVALUATION PROCEDURES AND BASIS OF SELECTION

- 4.1. Evaluation Procedures
- 4.2. Basis of Selection

PART 5 - CERTIFICATIONS

- 5.1. Certifications Required Precedent to Contract Award and Additional Information
- 5.2. Insurance – Proof of Capability

PART 6 - RESULTING CONTRACT CLAUSES

- 6.1. Security Requirement
- 6.2. Statement of Work
- 6.3. Standard Clauses and Conditions
- 6.4. Term of Contract
- 6.5. Authorities
- 6.6. Proactive Disclosure of Contracts with Former Public Servants
- 6.7. Payment
- 6.8. Invoicing Instructions
- 6.9. Certifications
- 6.10. Applicable Laws
- 6.11. Priority of Documents
- 6.12. Procurement Ombudsman
- 6.13. SACC Manual Clauses
- 6.14. Insurance – Specific Requirements

List of Annexes:

- Annex A Statement of Work
- Annex B Certifications Precedent to Contract Award
- Annex C Insurance Requirements
- Annex D Basis of Payment
- Annex E Janitorial Services Activity Log Sample
- Annex F Communication Log



Annex G	Security Requirements Check List
Annex H	Integrity Form – Bidder's Information
Annex I	Checklist for Bid Submission
Annex J	Corflex Operable Partitions



PART 1 - GENERAL INFORMATION

1.1. Security Requirement

1. Before award of a contract, the following conditions must be met:
 - (a) the Bidder's proposed individuals requiring access to classified or protected information, assets or sensitive work site(s) must meet the security requirements as indicated in Part 6 - Resulting Contract Clauses;
 - (b) the Bidder must provide the name of all individuals who will require access to classified or protected information, assets or sensitive work sites; fingerprinting may be required. This information must be provided within three business days of request.
2. Bidders are reminded to obtain the required security clearance promptly. Any delay in the award of a contract to allow the successful bidder to obtain the required clearance will be at the entire discretion of the Contracting Authority.
3. For additional information on security requirements, bidders should refer to the Industrial Security Program (ISP) of Public Works and Government Services Canada (<http://ssi-iss.tpsgc-pwgsc.gc.ca/index-eng.html>) website.

1.2. Statement of Work

The Work to be performed is detailed under Article 6.2 of the resulting contract clauses.

1.3. Debriefings

Bidders may request a debriefing on the results of the bid solicitation process. Bidders should make the request to the Contracting Authority within 15 working days of receipt of the results of the bid solicitation process. The debriefing may be in writing, by telephone or in person.

1.4. Procurement Ombudsman

The Office of the Procurement Ombudsman (OPO) was established by the Government of Canada to provide an independent avenue for suppliers to raise complaints regarding the award of contracts under \$25,000 for goods and under \$100,000 for services. You have the option of raising issues or concerns regarding the solicitation, or the award resulting from it, with the OPO by contacting them by telephone at 1-866-734-5169 or by e-mail at boa-opo@boa-opo.gc.ca. You can also obtain more information on the OPO services available to you at their website at www.opo-boa.gc.ca.

1.5 Trade Agreements

"The requirement is subject to the provisions of the the North American Free Trade Agreement (NAFTA), and the Agreement on Internal Trade (AIT)."



PART 2 - BIDDER INSTRUCTIONS

2.1. Standard Instructions, Clauses and Conditions

All instructions, clauses and conditions identified in the bid solicitation by number, date and title are set out in the *Standard Acquisition Clauses and Conditions Manual* (<https://buyandsell.gc.ca/policy-and-guidelines/standard-acquisition-clauses-and-conditions-manual>) issued by Public Works and Government Services Canada.

Revision to Departmental Name: As this solicitation is issued by Royal Canadian Mounted Police (RCMP), any reference to Public Works and Government Services Canada or PWGSC or its Minister contained in any term, condition or clause of this solicitation, including any individual SACC clauses incorporated by reference, will be interpreted as reference to RCMP or its Minister.

Bidders who submit a bid agree to be bound by the instructions, clauses and conditions of the bid solicitation and accept the clauses and conditions of the resulting contract.

The 2003 (2016-04-04) Standard Instructions - Goods or Services - Competitive Requirements, are incorporated by reference into and form part of the bid solicitation.

Subsection 5.4 of 2003, Standard Instructions - Goods or Services - Competitive Requirements, is amended as follows:

Delete: sixty (60) days

Insert: one hundred and eighty (180) days

2.2. Submission of Bids

Bids must be submitted only to RCMP Bid Receiving Unit by the date, time and place indicated on page 1 of the bid solicitation.

Due to the nature of the bid solicitation, bids transmitted by facsimile to RCMP will be accepted.

The Royal Canadian Mounted Police (RCMP) will not assume responsibility for bids or amendments directed to any other location or facsimile number.

2.3. Enquiries - Bid Solicitation

All enquiries must be submitted in writing to the Contracting Authority no later than five (5) calendar days before the bid closing date. Enquiries received after that time may not be answered.

Bidders should reference as accurately as possible the numbered item of the bid solicitation to which the enquiry relates. Care should be taken by bidders to explain each question in sufficient detail in order to enable Canada to provide an accurate answer. Technical enquiries that are of a proprietary nature must be clearly marked "proprietary" at each relevant item. Items identified as "proprietary" will be treated as such except where Canada determines that the enquiry is not



of a proprietary nature. Canada may edit the question(s) or may request that the Bidder do so, so that the proprietary nature of the question(s) is eliminated, and the enquiry can be answered to all bidders. Enquiries not submitted in a form that can be distributed to all bidders may not be answered by Canada.

2.4. Applicable Laws

Any resulting contract must be interpreted and governed, and the relations between the parties determined, by the laws in force in the Province of Saskatchewan.

Bidders may, at their discretion, substitute the applicable laws of a Canadian province or territory of their choice without affecting the validity of their bid, by deleting the name of the Canadian province or territory specified and inserting the name of the Canadian province or territory of their choice. If no change is made, it acknowledges that the applicable laws specified are acceptable to the bidders.

2.5. Optional Site Visit

It is recommended that the Bidder or a representative of the Bidder visit the work site. Arrangements have been made for the site visit to be held at 2020 – 9th Avenue West, Prince Albert, SK on June 15, 2017. The site visit will begin at 10:00 a.m.

Bidders are requested to communicate with the Contracting Authority no later than five (5) days prior to the scheduled site visit to confirm attendance and provide the name(s) of the person(s) who will attend. Bidders may be requested to sign an attendance sheet. Bidders who do not attend or do not send a representative will not be given an alternative appointment but they will not be precluded from submitting a bid. Any clarifications or changes to the bid solicitation resulting from the site visit will be included as an amendment to the bid solicitation.

2.6 Promotion of Direct Deposit Initiative

The following information is not related to the solicitation process:

An initiative within the Government of Canada called the Cheque Standardization Project has been established whereby eventually for all payments, cheque stubs will no longer be printed and, with few exceptions, will be processed via direct deposit. This option is only available when payment is made in Canadian dollars for deposit into a Canadian bank account. In an attempt to be proactive, RCMP Corporate Accounting is promoting the registration of RCMP suppliers for the upcoming change in the payment process.

If you are the successful bidder on this or any other RCMP requirement, you are encouraged to register with the RCMP for direct deposit. Please contact RCMP Corporate Accounting by email to receive a form entitled *Recipient Electronic Payment Registration Request* along with instructions for completion of the form.

Should you have any questions regarding the Cheque Standardization Project or if you want to register, please contact the following email: corporate_accounting@rcmp-grc.gc.ca



PART 3 - BID PREPARATION INSTRUCTIONS

3.1. Bid Preparation Instructions

Canada requests that bidders provide their bid in separately bound sections as follows:

Section I: Financial Bid (one (1) hard copy, Annex D)

Bidders must submit their financial bid in accordance with the Basis of Payment. The total amount of Applicable Taxes must be shown separately.

Section II: Certifications (one (1) hard copy, Annex B)

Bidders must submit the certifications required under Part 5.

Prices must appear in the financial bid only. No prices must be indicated in any other section of the bid.

Canada requests that bidders follow the format instructions described below in the preparation of their bid:

- (a) use 8.5 x 11 inch (216 mm x 279 mm) paper;
- (b) use a numbering system that corresponds to the bid solicitation.

In April 2006, Canada issued a policy directing federal departments and agencies to take the necessary steps to incorporate environmental considerations into the procurement process Policy on Green Procurement (<http://www.tpsgc-pwgsc.gc.ca/ecologisation-greening/achats-procurement/politique-policy-eng.html>). To assist Canada in reaching its objectives, bidders should:

- 1) use 8.5 x 11 inch (216 mm x 279 mm) paper containing fibre certified as originating from a sustainably-managed forest and containing minimum 30% recycled content; and
- 2) use an environmentally-preferable format including black and white printing instead of colour printing, printing double sided/duplex, using staples or clips instead of cerlox, duotangs or binders.

Section I: Financial Bid

Bidders must submit their financial bid in accordance with Annex D Basis of Payment. The total amount of Applicable Taxes must be shown separately.

Section II: Certifications

Bidders must submit certification required under Part 5.



PART 4 - EVALUATION PROCEDURES AND BASIS OF SELECTION

4.1. Evaluation Procedures

- (a) Bids will be assessed in accordance with the entire requirement of the bid solicitation including the financial evaluation criteria.
- (b) An evaluation team composed of representatives of Canada will evaluate the bids.

4.1.1. Financial Evaluation

The price of the bid will be evaluated in Canadian dollars, Applicable Taxes excluded, DDP Delivered Duty Paid, Canadian customs duties and excise taxes included.

4.2. Basis of Selection

A bid must comply with all requirements of the bid solicitation to be declared responsive. The responsive bid with the lowest evaluated price will be recommended for award of a contract.

PART 5 - CERTIFICATIONS

Bidders must provide the required certifications and associated information to be awarded a contract.

The certifications provided by bidders to Canada are subject to verification by Canada at all times. Unless specified otherwise, Canada will declare a bid non-responsive, or will declare a contractor in default in carrying out any of its obligations under the Contract, if any certification made by the Bidder is found to be untrue whether made knowingly or unknowingly, during the bid evaluation period or during the contract period.

The Contracting Authority will have the right to ask for additional information to verify the Bidder's certifications. Failure to comply and to cooperate with any request or requirement imposed by the Contracting Authority may render the bid non-responsive or constitute a default under the Contract.

5.1. Certifications Precedent to Contract Award and Additional Information

The certifications and additional information listed below should be submitted with the bid but may be submitted afterwards. If any of these required certifications or additional information is not completed and submitted as requested, the Contracting Authority will inform the Bidder of a time frame within which to provide the information. Failure to provide the certifications or the additional information listed below within the time frame specified will render the bid non-responsive.

5.1.1. Integrity Provisions

In accordance with the *Ineligibility and Suspension Policy* (<http://www.tpsgc-pwgsc.gc.ca/ci-if/politique-policy-eng.html>), the Bidder must provide the required documentation (Refer to Annex "H"), as applicable, to be given further consideration in the procurement process:

- Declaration of Convicted Offences (as applicable)



- Required Documentation

5.1.2. Federal Contractors Program for Employment Equity - Bid Certification

By submitting a bid, the Bidder certifies that the Bidder, and any of the Bidder's members if the Bidder is a Joint Venture, is not named on the Federal Contractors Program (FCP) for employment equity "[FCP Limited Eligibility to Bid](http://www.labour.gc.ca/eng/standards_equity/eq/emp/fcp/list/inelig.shtml)" list (http://www.labour.gc.ca/eng/standards_equity/eq/emp/fcp/list/inelig.shtml) available from [Employment and Social Development Canada \(ESDC\) - Labour's](#) website.

Canada will have the right to declare a bid non-responsive if the Bidder, or any member of the Bidder if the Bidder is a Joint Venture, appears on the "[FCP Limited Eligibility to Bid](#)" list at the time of contract award.

5.1.3. Additional Certifications Precedent to Contract Award

5.1.3.1. Former Public Servant

Refer to Annex "B"

5.2. Insurance – Proof of Capability

The Bidder must provide a letter from an insurance broker or an insurance company licensed to operate in Canada stating that the Bidder, if awarded a contract as a result of the bid solicitation, can be insured in accordance with the Insurance Requirements specified in Annex "C".

If the information is not provided in the bid package, the Contracting Authority will so inform the Bidder and provide the Bidder with a time frame within which to meet the requirement. Failure to comply with the request of the Contracting Authority and meet the requirement within that time period will render the bid non-responsive.

Policy minimum limits are:

- a) \$2,000,000 Each Occurrence Limit;
- b) \$5,000,000 General Aggregate Limit per policy year if the policy contains a General Aggregate; and
- c) \$2,000,000 Products/Completed Operations Aggregate Limit.



PART 6 - RESULTING CONTRACT CLAUSES

The following clauses and conditions apply to and form part of any contract resulting from the bid solicitation.

6.1. Security Requirement

6.1.1. The following security requirement (SRCL at Annex "G" and related clauses) applies and form part of the Contract.

The Contractor (if an individual) and all of the contractor's personnel/subcontractors who may work on site must hold a valid "**Reliability Status Security Clearance**" issued by RCMP Departmental Security.

Only those individuals who have met the security clearance requirements will be allowed access to the site of the work.

6.2. Statement of Work

The Contractor must perform the Work in accordance with the Statement of Work at Annex "A".

6.3. Standard Clauses and Conditions

All clauses and conditions identified in the Contract by number, date and title are set out in the *Standard Acquisition Clauses and Conditions Manual* (<https://buyandsell.gc.ca/policy-and-guidelines/standard-acquisition-clauses-and-conditions-manual>) issued by Public Works and Government Services Canada.

Revision to Departmental Name: As this contract is issued by RCMP, any reference to Public Works and Government Services Canada or PWGSC or its Minister contained in any term, condition or clause of this contract, including any individual SACC clauses incorporated by reference, will be interpreted as reference to RCMP or its Minister.

6.3.1 General Conditions

2010C (2016-04-04), General Conditions - Services (Medium Complexity) apply to and form part of the Contract.

6.4. Term of Contract

6.4.1. Period of the Contract

The period of the Contract is from date of Contract for a **two (2) year period**.



6.4.2. Option to Extend the Contract

The Contractor grants to Canada the irrevocable option to extend the term of the Contract by up to **two (2) additional one (1) year periods** under the same conditions. The Contractor agrees that during the extended period of the Contract, it will be paid in accordance with the applicable provisions as set out in the Basis of Payment.

Canada may exercise this option at any time by sending a written notice to the Contractor at **least thirty (30) calendar days** before the expiry date of the contract. The option may only be exercised by the Contracting Authority, and will be evidenced for administrative purposes only, through a contract amendment.

6.4.3. Delivery Points

Delivery of the requirement will be made to delivery point specified at Annex A 3.3. of the Contract.

6.5. Authorities

6.5.1. Contracting Authority

The Contracting Authority for the Contract is:

Rachel Sookoo
Procurement & Contracting Officer
Royal Canadian Mounted Police
Procurement & Contracting Services Unit
Telephone: 639-625-3291
Facsimile: 306-780-5232
E-mail address: rachel.sookoo@rcmp-grc.gc.ca

The Contracting Authority is responsible for the management of the Contract and any changes to the Contract must be authorized in writing by the Contracting Authority. The Contractor must not perform work in excess of or outside the scope of the Contract based on verbal or written requests or instructions from anybody other than the Contracting Authority.

6.5.2. Technical Authority

The Technical Authority for the Contract is: (To be identified at Contract Award).

Name
Senior Asset Manager
Royal Canadian Mounted Police
Real Property (**Insert province**)
Telephone: **XXX-XXX-XXXX**
Facsimile: **XXX-XXX-XXXX**
E-mail address: XXX.XXX@rcmp-grc.gc.ca



The Technical Authority is the representative of the department or agency for whom is responsible for all matters concerning the technical content of the Work under the Contract. Technical matters are to be discussed with the Technical Authority, however the Technical Authority has no authority to authorize changes to the scope of the Work. Changes to the scope of the Work can only be made through a contract amendment issued by the Contracting Authority.

6.5.3. Site Authority

The Site Authority for the Contract is:

Title: Detachment Commander or Designate
Telephone : (To be identified at Contract Award.)

The Site Authority is the representative of the department or agency for whom the Work is being carried out under the Contract and is the local contact for the Contractor. Technical matters may be discussed with the Site Authority whom must advise the Technical Authority, however the Site Authority has no authority to authorize changes to the scope of the Work. Changes to the scope of the Work can only be made through a contract amendment issued by the Contracting Authority.

6.5.3. Contractor's Representative

The Contractor's Representative responsible for general enquiries and delivery follow-up is: (The Contractor's Representative will be identified at Contract Award)

Name: _____
Telephone No. _____
Facsimile No. _____
E-mail address: _____

6.6. Proactive Disclosure of Contracts with Former Public Servants

By providing information on its status, with respect to being a former public servant in receipt of a [Public Service Superannuation Act](#) (PSSA) pension, the Contractor has agreed that this information will be reported on departmental websites as part of the published proactive disclosure reports, in accordance with [Contracting Policy Notice: 2012-2](#) of the Treasury Board Secretariat of Canada.

6.7. Payment

6.7.1. Basis of Payment

In consideration of the Contractor satisfactorily completing all of its obligations under the Contract, the Contractor will be paid a firm monthly price as specified in "Annex "D" for a cost of \$_____. Customs duties are "included" and Goods and Services Tax or Harmonized Sales Tax is extra, if applicable.



Canada will not pay the Contractor for any design changes, modifications or interpretations of the Work, unless they have been approved, in writing, by the Contracting Authority before their incorporation into the Work.

6.7.2. Monthly Payment

Refer to SACC Manual clause H1008C (2008-05-12) Monthly Payment.

6.8. Invoicing Instructions

The Contractor must submit invoices in accordance with the information required in Section 10 of 2010C (2016-04-04), General Conditions - Services (Medium Complexity).

An invoice must be submitted to Detachment Commander or Asset Manager (pick which one) on the first working day of the following month.

The address where the invoice are to be sent to, will be indicated at Contract Award.

6.9. Certifications

6.9.1. Compliance

Unless specified otherwise, the continuous compliance with the certifications provided by the Contractor in its bid or precedent to contract award, and the ongoing cooperation in providing additional information are conditions of the Contract and failure to comply will constitute the Contractor in default. Certifications are subject to verification by Canada during the entire period of the Contract.

6.10. Applicable Laws

The Contract must be interpreted and governed, and the relations between the parties determined, by the laws in force in the Province of Saskatchewan.

6.11. Priority of Documents

If there is a discrepancy between the wording of any documents that appear on the list, the wording of the document that first appears on the list has priority over the wording of any document that subsequently appears on the list.

- (a) the Articles of Agreement;
- (b) 2010C (2016-04-04) General Conditions - Services (Medium Complexity);
- (c) Annex A, Statement of Work
- (d) Annex G Security Requirements Checklist
- (e) Annex C, Insurance Requirements
- (f) Annex D, Basis of Payment
- (g) Annex E, Sample of Activity Log
- (h) Annex F, Communication Log
- (i) the Contractor's bid dated _____, as amended on _____



6.12. Procurement Ombudsman

6.12.1. Dispute Resolution Services

The parties understand that the Procurement Ombudsman appointed pursuant to Subsection 22.1(1) of the *Department of Public Works and Government Services Act* will, on request, and consent of the parties, to participate in an alternative dispute resolution process to resolve any dispute between the parties respecting the interpretation or application of a term or condition of this contract and their consent to bear the cost of such process, provide to the parties a proposal for an alternative dispute resolution process to resolve their dispute.

The Office of the Procurement Ombudsman may be contacted by telephone at 1-866-734-5169 or by e-mail at boa-opo@boa-opo.gc.ca.

6.12.2. Contract Administration

The parties understand that the Procurement Ombudsman appointed pursuant to Subsection 22.1(1) of the *Department of Public Works and Government Services Act* will review a complaint filed by [*the supplier or the contractor or the name of the entity awarded this contract*] respecting administration of this contract if the requirements of Subsection 22.2(1) of the *Department of Public Works and Government Services Act* and Sections 15 and 16 of the *Procurement Ombudsman Regulations* have been met, and the interpretation and application of the terms and conditions and the scope of the work of this contract are not in dispute.

The Office of the Procurement Ombudsman may be contacted by telephone at 1-866-734-5169 or by e-mail at boa-opo@boa-opo.gc.ca.

6.13. SACC Manual Clauses

Refer to the following SACC Manual Clause:

A9068C (2010-01-11), Government Site Regulations;

6.14. Insurance – Specific Requirements

The Contractor must comply with the insurance requirements specified in Annex "C". The Contractor must maintain the required insurance coverage for the duration of the Contract. Compliance with the insurance requirements does not release the Contractor from or reduce its liability under the Contract.

The Contractor is responsible for deciding if additional insurance coverage is necessary to fulfill its obligation under the Contract and to ensure compliance with any applicable law. Any additional insurance coverage is at the Contractor's expense, and for its own benefit and protection.

The Contractor must forward to the Contracting Authority within ten (10) days after the date of award of the Contract, a Certificate of Insurance evidencing the insurance coverage and



confirming that the insurance policy complying with the requirements is in force. For Canadian-based Contractors, coverage must be placed with an Insurer licensed to carry out business in Canada, however, for Foreign-based Contractors, coverage must be placed with an Insurer with an A.M. Best Rating no less than "A-". The Contractor must, if requested by the Contracting Authority, forward to Canada a certified true copy of all applicable insurance policies.



**ANNEX "A"
STATEMENT OF WORK**

1. SCOPE

1.1. Introduction

Janitorial services for RCMP Prince Albert North District Building.

1.2. Objectives of the Requirement

To maintain the cleanliness of RCMP property using standard cleaning procedures, cleaning products and equipment.

1.3. Background and Specific Scope of the Requirement

The RCMP Prince Albert North District Headquarters Building is a two story building, approximately 2012 m2 in size: Basement area 482 m2; Main floor area 1076 M2.

The main floor consists of offices, meeting rooms, washrooms, janitors' closet and kitchenette.

The basement area consists of a gym area, washroom/change rooms, janitors' closet, storage rooms, offices, garbage bays, and mechanical rooms.

NOTE; the total building size is greater than the area requiring cleaning. There are a number of secure rooms to which access is not provided and cleaning is not required.

All areas are to be cleaned in accordance with Annex A 2. Requirements.

This is a contract for the performance of janitorial services and the contractor is engaged under the contract as an independent contractor for the sole purpose of providing janitorial services.

Neither the contractor nor any of the contractor's personnel is engaged by the contract as an employee, servant or agent of Her Majesty.

The contractor agrees to be solely responsible for any and all payments and/or deductions required to be made including those required for Canada Pension Plan, Employment Insurance, Worker's Compensation or Income Tax.

2. REQUIREMENTS

2.1. Tasks, Activities, Deliverables and Milestones

2.1.1. Tasks

2.1.1.1. Frequency Definitions:

Frequency	Frq. Acron.	Type
Three times per week	3TW	Regular
As required	AR	Non-Routine



Daily (5 days per week)	D	Regular
Every 3rd month	E3M	Quarterly
Every 6th month	E6M	Semi-Annually
Monthly	M	Routine
Twice weekly	TW	Regular
Weekly	W	Routine
Yearly	Y	Annually

2.1.1.2. Activities

Regular
Daily (5 days per week) (D)
Vacuum/clean entire floor area and stairways.
Dust all horizontal surfaces, counter tops and furniture, picture frames, cabinets, fixtures, window sills, ledges, etc.
Empty and clean all exterior/perimeter entrance ashtrays where applicable.
Clean both sides of entrance door glass and side lights.
Empty all waste baskets and place waste in containers ready for burning or disposal. Dispose of garbage as per the RCMP Site Authority or designate's directions.
Wash and disinfect washrooms to ensure sanitary conditions. Including toilet seats (both sides), bowls, urinals, wash basins, all flush tanks, dispensers, mirrors, shelves, high ledges and all exposed piping and plumbing fixtures, floors etc.
Remove waste paper from washrooms. Empty, wash and disinfect sani-cans in washrooms. Replace sani-bags.
Ensure adequate supplies exist in washrooms. Replenish paper towels, toilet tissue and soap.
Sweep and damp mop all vinyl and tile flooring.
Vacuum all carpet, spot clean as necessary, remove salt stains from all walkway mats.
Keep mirrors throughout the building clean and polished.
Clean and polish all interior and exterior ornamental metal.
Damp mop and/or polish public lobbies and entrance hallways and heavy traffic areas.
Routine
Weekly (W)
Wash and disinfect refuse receptacles in washrooms.
Vacuum upholstered furniture and freestanding screens, clean/polish all leather, vinyl and leatherette upholstered furniture.
Monthly (M)
Dust window blinds.
Wash all finger marks and smudges from walls, doors, partitions, ledges and framework.
Wash all glass partitions and cabinet glass.
Non-Routine
As Required (AR)
Unclog and clean toilets and drains immediately, providing no plumbing work is required. Notify the Site Authority or Site Authority's designate if plumbing work is necessary.



Replace burnt out light bulbs and fluorescent tubes. Dry wipe tubes, bulbs and shielding when making replacements.
Remove, clean and replace mats.
Ensure that steps, entrances and sidewalks to the building are clear of snow and ice, and apply sand/ice melt as required (in a 7 ft radius from entrance ways – See Annex “A” - Section 2.3.2, Weather.)
Keep the main and service entrances clear of debris, i.e. paper, carton, refuse cans, slush, sand etc. in order to maintain a clean and tidy appearance at all times.
Clean/remove spider webs from exterior light fixtures and above doorways.
Follow cleaning instructions for Corflex Operable Partitions (Annex "J")
Quarterly
Every 3rd Month (E3M)
Wash door grilles, air intake grilles, air diffusers and metal work.
Semi-Annually
Every 6th Month (E6M)
Strip and wax all vinyl and tile floors, remove gum and other foreign residue.
Wash washroom walls.
Dust and polish all wood paneling, walls and partitions.
Wash both sides of all exterior windows, including ceiling lights under them, sash window framing, leaving all surfaces dry and free of streak marks.
Clean all exterior light fixtures as required (minimum twice per year).
Annually
Yearly (Y)
Clean all light fixtures. Include incandescent fixtures and bulbs and washing outside and inside of fluorescent covers and tubes.
Clean, wash, etc., window coverings, i.e. venetian blinds or draperies.
Wash all walls, ceilings, partitions and woodwork.
Steam clean or shampoo all carpets using water extractor type machine. All labour, equipment and materials for this work to be supplied by contractor.

2.1.1.3. Special Occurrences

The contractor shall promptly report to the Site Authority or Site Authority’s designate and record in the Janitorial Services Activity Log book provided by the Site Authority or Site Authority’s designate (See Annex E for a sample of a Janitorial Services Activity Log page):

- every instance involving hazardous materials, situations or occurrences;
- water and/or fire related instances, including those of a minor nature;
- any and all damage or injury to property and/or people;
- repairs and maintenance related to life and safety systems, other than regular cyclical repairs and maintenance; and
- any other instances that are or could potentially become a liability to the RCMP or which may require follow up and/or action by the RCMP.



2.2. Specifications and Standards

2.2.1. Materials and Equipment

2.2.1.1. The **Contractor** is responsible to provide all cleaning products and disinfectants, all tools, equipment and equipment consumables including mops, pails and vacuum cleaners unless otherwise stipulated.

2.2.1.2. The **Contractor** is responsible to provide all the following consumables:

- Hand Soap
- Garbage bags
- Paper towels
- Sani-bags
- Toilet tissue

2.2.1.3. Sample Consumables and Estimated Usages
(Quantities are estimated usages only and are subject to change):

Toilet Tissue Dispenser(s): Bobrick B-2888

Hand Soap Dispenser(s): Bobrick B-2111

Paper Towel Dispenser(s): Bobrick B-263, Bobrick B-2974

Technical data for these dispensers, and the consumables they dispense, can be found at the Bobrick website: www.bobrick.com

Consumables usage is based on occupancy in the building at 2.2.1.5. below.

2.2.1.4. Materials to be supplied by the RCMP that the Contractor may need to perform activities listed in 2.1.1.2. are:

- Rubber matting
- Light bulbs
- Sand/ice melt

2.2.1.5. Total number of personnel at the detachment is 40.

2.2.1.6. All cleaning products used will have reduced levels of hazardous materials as well as be free of ammonia and wherever possible cleaning products should be purchased in concentrated form or in returnable packages to reduce waste. Look for the EcoLogo Program or Green Seal.

2.2.1.7. Paper and plastic products should contain post-consumer recycled paper or plastic. Look for the EcoLogo Program or Green Seal.

2.2.1.8. Cleaning products and paper products must be no-scent or low-scent products.

2.2.1.9. It is incumbent upon the provider of janitorial services to follow best industry practices and to use products and processes which ensure no cross-



contamination between cells/detention areas, Member/guard/matron or public washrooms, food preparation and kitchen areas.

- 2.2.1.10. The Contractor shall ensure that all products used in the work place are classified and labeled according to the Workplace Hazardous Materials Information Systems (WHMIS) legislation which requires the employer to provide detailed worker education regarding potential health effects of hazardous materials in their work environment and how they can be handled and disposed of safely.

2.3. Technical, Operational and Organizational Environment

2.3.1. Hours of Work

Cleaning will be required 5 days a week. Hours to work of the cleaning staff depend upon the normal occupancy hours of the building, and are to be determined by the proposed janitorial contractor and the Royal Canadian Mounted Police (RCMP) Site Authority upon contract award.

2.3.2. Weather

Inclement weather conditions and other circumstances will at times necessitate additional cleaning of entry ways and high traffic areas inside and/or outside the building as per Annex A. The Contractor must comply without additional cost, when performance is required during normal working hours.

2.3.3. Floor Coverings

There will be no adjustment to the contract amount where the existing floor covering is converted to another type during the term of the Contract.

2.4. Method and Source of Acceptance

All cleaning shall be performed to the satisfaction of the RCMP Site Authority or their designated representative and will be inspected at least once a month during this contract. RCMP will have the right to reject any work that is not in accordance with the requirements of the Contract and require its correction at the Contractor's expense.

2.5. Reporting Requirements

Within 30 days of contract award, the contractor in consultation with the RCMP Site Authority, will determine a schedule in which the work will be done. The schedule is to be signed off by both the contractor and the RCMP Site Authority or designate. The schedule will be adhered to and will be part of the performance measures. A copy of the schedule is to be provided to the Contracting Authority by the RCMP Site Authority or designate within a day or two of it being signed.

An activity log will be maintained at the site by the contractor in which the contractor shall record, date and initial all the completed scheduled/periodic work performed. The log shall be provided to the RCMP Site Authority or designate on a monthly basis. The RCMP Site Authority or designate will review and sign off on the activity log. A copy of the signed activity log must be sent to the Contracting Authority by the RCMP Site Authority or designate within a day or two of it being signed.



Refer to Annex E for a sample of the activity log.

2.6. Project Management Control Procedures

The RCMP Site Authority will:

- Review against the schedule, validate work was completed and sign the activity log on a monthly basis;
- Record any communication with the contractor on the communication log (see Annex F) and submit a copy to the Contracting Authority; and
- Ensure the services are being performed in accordance with the contract and to record on the Communication Log when this is not the case and provide a copy to the Contracting Authority.

3. ADDITIONAL INFORMATION

3.1. Canada's Obligations

The RCMP will provide the contractor the following upon the contractor receiving the appropriate RCMP security clearance:

- Access to the detachment
- Utility room/janitorial closet for supplies and equipment
- Any consumables identified in 2.2.1.

3.2. Contractor's Obligations

The Contractor must:

- Keep utility room/janitorial closet clean and free of debris at all times and serviced as per the corresponding area in the building.
- All equipment and materials to be stored neatly strictly adhering to all fire prevention practices.
- Provide any consumables identified in 2.2.1.
- Create a schedule within 30 days of contract award that must be agreed upon and signed by both parties.
- Maintain a log that records and dates all completed scheduled/periodic work performed as well as any instance identified in 2.1.1.3.
- Maintain a binder on site with up-to-date Material Safety Data Sheets (MSDS) for all products and materials used in the work site (when available from manufacturer).
- Notify RCMP Site Authority in advance by at least 5 days if looking to make a change to the agreed upon schedule, if circumstances allow.
- Follow best industry practices and to use products and processes which ensure no cross-contamination between cells/detention areas, Member/guard/matron or public washrooms, and food preparation and kitchen areas.
- Perform the work in compliance with the Canada Labour code – part II, or relevant provincial occupational health and safety act and regulations, the national fire code, and applicable municipal regulations.



- Ensure all safety measures respecting personnel and fire hazards recommended by the National and Provincial codes and/or prescribed by the authorities having jurisdiction, shall be observed at all times.

3.3. Location of Work, Work site and Delivery Point

RCMP Prince Albert North District Building
2020 – 9th Avenue West
Prince Albert, SK S6V 6J7

4. PROJECT SCHEDULE

4.1. Schedule and Estimated Level of Effort (Work Breakdown Structure)

Refer to Section 2.1.1.2.

5. APPLICABLE DOCUMENTS AND GLOSSARY

5.1. Applicable Documents

5.1.1. References

The references listed below are the standards, rules, guidelines and regulations that the Contractor and the Contractor's personnel must adhere to while performing the duties of this contract.

5.1.1.1. Janitorial Contract (SERVICE CONTRACT/SPECIFICATION CUSTODIAL MAINTENANCE)

Treasury Board of Canada Secretariat
Procedures for Liaison with Private Contractors - Jurisdiction
<http://www.tbs-sct.gc.ca/pol/doc-eng.aspx?id=12563§ion=text>

5.1.1.2. Saskatchewan Occupational Health and Safety Act Part II (6) General Duties of Contractors

<http://www.qp.gov.sk.ca/documents/English/Statutes/Statutes/O1-1.pdf>

5.1.1.3. Canadian Centre for Occupational Health and Safety (CCOHS) Canada's National Occupational Health & Safety Resource -Sanitation and Infection Control for Cleaning staff

http://www.ccohs.ca/oshanswers/hsprograms/cleaning_staff.html

5.1.1.4. Public Health Agency of Canada Infection Control Guidelines - Hand Washing, Cleaning, Disinfection and Sterilization in Health Care

<http://www.phac-aspc.gc.ca/publicat/ccdr-rmtc/98pdf/cdr24s8e.pdf>



5.2. Relevant Terms, Acronyms and Glossaries

RCMP – Royal Canadian Mounted Police

Cleaning Products – are chemical products used for the purpose of cleaning.

Environmentally preferable goods and services are those which have a reduced negative effect on human health and the environment over their full life cycle when compared with competing products or services. They make efficient use of raw materials, energy and water; generate a minimum of waste; and/or minimize the release of harmful substances into the environment during their production or use. Environmentally preferable goods may also have one or more of the following characteristics; reduced packaging, reduced maintenance requirements and ease of re-use, refurbishment, re-manufacture or recycling at end of life.

Employer – is the contractor and/or bidder.



ANNEX "B" CERTIFICATIONS PRECEDENT TO CONTRACT AWARD

The certifications listed below should be completed and submitted with the bid, but may be submitted afterwards. If any of these required certifications is not completed and submitted as requested, the Contracting Authority will so inform the Bidder and provide the Bidder with a time frame within which to meet the requirement. Failure to comply with the request of the Contracting Authority and meet the requirement within that time period will render the bid non-responsive.

B.1 Former Public Servant – Competitive Bid

Contracts awarded to former public servants (FPS) in receipt of a pension or of a lump sum payment must bear the closest public scrutiny, and reflect fairness in the spending of public funds. In order to comply with Treasury Board policies and directives on contracts awarded to FPSs, bidders must provide the information required below before contract award. If the answer to the questions and, as applicable the information required have not been received by the time the evaluation of bids is completed, Canada will inform the Bidder of a time frame within which to provide the information. Failure to comply with Canada's request and meet the requirement within the prescribed time frame will render the bid non-responsive.

Definitions

For the purposes of this clause, "former public servant" is any former member of a department as defined in the [Financial Administration Act](#), R.S., 1985, c. F-11, a former member of the Canadian Armed Forces or a former member of the Royal Canadian Mounted Police. A former public servant may be:

- a. an individual;
- b. an individual who has incorporated;
- c. a partnership made of former public servants; or
- d. a sole proprietorship or entity where the affected individual has a controlling or major interest in the entity.

"lump sum payment period" means the period measured in weeks of salary, for which payment has been made to facilitate the transition to retirement or to other employment as a result of the implementation of various programs to reduce the size of the Public Service. The lump sum payment period does not include the period of severance pay, which is measured in a like manner.

"pension" means a pension or annual allowance paid under the [Public Service Superannuation Act](#) (PSSA), R.S., 1985, c. P-36, and any increases paid pursuant to the [Supplementary Retirement Benefits Act](#), R.S., 1985, c. S-24 as it affects the PSSA. It does not include pensions payable pursuant to the [Canadian Forces Superannuation Act](#), R.S., 1985, c. C-17, the [Defence Services Pension Continuation Act](#), 1970, c. D-3, the [Royal Canadian Mounted Police Pension Continuation Act](#), 1970, c. R-10, and the [Royal Canadian Mounted Police Superannuation Act](#), R.S., 1985, c. R-11, the [Members of Parliament Retiring Allowances Act](#), R.S. 1985, c. M-5, and that portion of pension payable to the [Canada Pension Plan Act](#), R.S., 1985, c. C-8.



Former Public Servant in Receipt of a Pension

As per the above definitions, is the Bidder a FPS in receipt of a pension? **Yes** () **No** ()

If so, the Bidder must provide the following information, for all FPSs in receipt of a pension, as applicable:

- a. name of former public servant;
- b. date of termination of employment or retirement from the Public Service.

By providing this information, Bidders agree that the successful Bidder's status, with respect to being a former public servant in receipt of a pension, will be reported on departmental websites as part of the published proactive disclosure reports in accordance with [Contracting Policy Notice: 2012-2](#) and the [Guidelines on the Proactive Disclosure of Contracts](#).

Work Force Adjustment Directive

Is the Bidder a FPS who received a lump sum payment pursuant to the terms of the Work Force Adjustment Directive? **Yes** () **No** ()

If so, the Bidder must provide the following information:

- a. name of former public servant;
- b. conditions of the lump sum payment incentive;
- c. date of termination of employment;
- d. amount of lump sum payment;
- e. rate of pay on which lump sum payment is based;
- f. period of lump sum payment including start date, end date and number of weeks;
- g. number and amount (professional fees) of other contracts subject to the restrictions of a work force adjustment program.

For all contracts awarded during the lump sum payment period, the total amount of fees that may be paid to a FPS who received a lump sum payment is \$5,000, including Applicable Taxes.

Certification

The Bidder certifies that the information submitted by the Bidder in response to the above requirements is accurate and complete.



ANNEX “C” INSURANCE REQUIREMENTS

COMMERCIAL GENERAL LIABILITY INSURANCE REQUIREMENTS

1. The Contractor must obtain Commercial General Liability Insurance, and maintain it in force throughout the duration of the Contract, in an amount usual for a contract of this nature, but for not less than \$2,000,000 per accident or occurrence and in the annual aggregate.
2. The Commercial General Liability policy must include the following:
 - a. Additional Insured: Canada is added as an additional insured, but only with respect to liability arising out of the Contractor's performance of the Contract. The interest of Canada should read as follows: Canada, as represented by Public Works and Government Services Canada.
 - b. Bodily Injury and Property Damage to third parties arising out of the operations of the Contractor.
 - c. Products and Completed Operations: Coverage for bodily injury or property damage arising out of goods or products manufactured, sold, handled, or distributed by the Contractor and/or arising out of operations that have been completed by the Contractor.
 - d. Personal Injury: While not limited to, the coverage must include Violation of Privacy, Libel and Slander, False Arrest, Detention or Imprisonment and Defamation of Character.
 - e. Cross Liability/Separation of Insureds: Without increasing the limit of liability, the policy must protect all insured parties to the full extent of coverage provided. Further, the policy must apply to each Insured in the same manner and to the same extent as if a separate policy had been issued to each.
 - f. Blanket Contractual Liability: The policy must, on a blanket basis or by specific reference to the Contract, extend to assumed liabilities with respect to contractual provisions.
 - g. Employees and, if applicable, Volunteers must be included as Additional Insured.
 - h. Employers' Liability (or confirmation that all employees are covered by Worker's compensation (WSIB) or similar program)
 - i. Broad Form Property Damage including Completed Operations: Expands the Property Damage coverage to include certain losses that would otherwise be excluded by the standard care, custody or control exclusion found in a standard policy.
 - j. Notice of Cancellation: The Insurer will endeavour to provide the Contracting Authority thirty (30) days written notice of policy cancellation.
 - k. If the policy is written on a claims-made basis, coverage must be in place for a period of at least 12 months after the completion or termination of the Contract.
 - l. Owner's or Contractor's Protective Liability: Covers the damages that the Contractor becomes legally obligated to pay arising out of the operations of a subcontractor.



- m. Sudden and Accidental Pollution Liability (minimum 120 hours): To protect the Contractor for liabilities arising from damages caused by accidental pollution incidents.
- n. Litigation Rights: Pursuant to subsection 5(d) of the [Department of Justice Act](#), S.C. 1993, c. J-2, s.1, if a suit is instituted for or against Canada which the Insurer would, but for this clause, have the right to pursue or defend on behalf of Canada as an Additional Named Insured under the insurance policy, the Insurer must promptly contact the Attorney General of Canada to agree on the legal strategies by sending a letter, by registered mail or by courier, with an acknowledgement of receipt.

Send to:

Senior General Counsel,
Civil Litigation Section,
Department of Justice
234 Wellington Street, East Tower
Ottawa, Ontario K1A 0H8

A copy of the letter must be sent to the Contracting Authority. Canada reserves the right to co-defend any action brought against Canada. All expenses incurred by Canada to co-defend such actions will be at Canada's expense. If Canada decides to co-defend any action brought against it, and Canada does not agree to a proposed settlement agreed to by the Contractor's insurer and the plaintiff(s) that would result in the settlement or dismissal of the action against Canada, then Canada will be responsible to the Contractor's insurer for any difference between the proposed settlement amount and the amount finally awarded or paid to the plaintiffs (inclusive of costs and interest) on behalf of Canada.



**ANNEX “D”
BASIS OF PAYMENT**

Please Note:

Annex “D” must be completed in its entirety or the tender/bid will be considered non-responsive and will not be evaluated.

- Prices are firm.
- Prices are to include the complete cost of performing the work under this contract.
- Firm Prices are in Canadian Dollars.
- Prices do not include GST, however GST will be added as a separate item, if applicable, on any invoice issued as a result of a Contract.

Bidder’s Pricing

Item	Description	Rate	Term	Price
1	Janitorial Services – Initial 2 year term Inclusive rate per month, excluding GST	\$ _____/month	X 24 months=	\$ _____
2	Janitorial Services – 1 st one (1) year option period Inclusive rate per month, excluding GST	\$ _____/month	X 12 months=	\$ _____
3	Janitorial Services – 2 nd one (1) year option period Inclusive rate per month, excluding GST	\$ _____/month	X 12 months=	\$ _____
Total Price of Bid:				\$ _____



ANNEX "E" Sample Janitorial Services Activity Log

JANITORIAL SERVICES
ACTIVITY LOG

MONTH/YEAR

DESCRIPTION	FRQY	INITIAL	MON	INITIAL	TUES	INITIAL	WED	INITIAL	THURS	INITIAL	FRI	NOTES
Regular												
Daily (6 days per week) (D)												
Vacuum/clean entire floor area and stairways.												
Dust all horizontal surfaces, counter tops and furniture, picture frames, cabinets, fixtures, window sills, ledges, etc.												
Empty and clean all exterior/perimeter entrance ashtrays where applicable.												
Clean both sides of entrance door glass and side lights.												
Empty all waste baskets and place waste in containers ready for burning or disposal. Dispose of garbage as per the RCMP Site Authority or designate's directions.												
Wash and disinfect washrooms to ensure sanitary conditions. Including toilet seats (both sides), bowls, urinals, wash basins, all flush tanks, dispensers, mirrors, shelves, high ledges and all exposed piping and plumbing fixtures, floors etc.												
Remove waste paper from washrooms. Empty, wash and disinfect sani-cans in washrooms. Replace sani-bags.												
Ensure adequate supplies exist in washrooms. Replenish paper towels, toilet tissue and soap.												
Sweep and damp mop all vinyl and tile flooring.												
Vacuum all carpet, spot clean as necessary, remove salt stains from all walkway mats.												
Keep mirrors throughout the building clean and polished.												
Clean and polish all interior and exterior ornamental metal.												
Damp mop and/or polish public lobbies and entrance hallways and heavy traffic areas.												

RCMP Site Authority (Print Name)

RCMP Site Authority Signature

Date

© PROCUREMENT-MMS/Arbitral-Grounds-Snow/Templates/TEMPLATES/Proposed Template



Annex "F" Communication Log

RCMP-GRC



ROYAL CANADIAN MOUNTED POLICE • GENDARMERIE ROYALE DU CANADA

COMMUNICATION LOG

Contractor	Contract Number	Date

Work Location	RCMP Site Authority/Designate

Summary of Occurrence/Observation/Incident

Summary of Discussion of Occurrence/Observation/Incident with Contractor

Resolution/Agreement

Contractor (Print Name and Sign)	Date	RCMP Site Authority (Print Name and Sign)	Date



ANNEX "G" SECURITY REQUIREMENTS CHECKLIST

SRCL# 2016-1116242



Government of Canada / Gouvernement du Canada

Contract Number / Numéro du contrat

Security Classification / Classification de sécurité

SECURITY REQUIREMENTS CHECK LIST (SRCL)

LISTE DE VÉRIFICATION DES EXIGENCES RELATIVES À LA SÉCURITÉ (LVERS)

PART A - CONTRACT INFORMATION / PARTIE A - INFORMATION CONTRACTUELLE	
1. Originating Government Department or Organization / Ministère ou organisme gouvernemental d'origine RCMP	2. Branch or Directorate / Direction générale ou Direction Property Management
3. a) Subcontract Number / Numéro du contrat de sous-traitance	3. b) Name and Address of Subcontractor / Nom et adresse du sous-traitant
4. Brief Description of Work / Brève description du travail Blanket SRCL for the 2016/2017 fiscal year for janitorial contracts in "F" Division: 1) RCMP Reliability Status for all contractors needing unescorted access to Detachment and offices 2) FAZ (Facility Access with escort) for administrative buildings (HQ, Lab, Central and North Districts for example) for cleaning activities not done on a daily basis i.e. carpet cleaning, floor waxing, window washing	
5. a) Will the supplier require access to Controlled Goods? / Le fournisseur aura-t-il accès à des marchandises contrôlées?	<input checked="" type="checkbox"/> No / Non <input type="checkbox"/> Yes / Oui
5. b) Will the supplier require access to unclassified military technical data subject to the provisions of the Technical Data Control Regulations? / Le fournisseur aura-t-il accès à des données techniques militaires non classifiées qui sont assujetties aux dispositions du Règlement sur le contrôle des données techniques?	<input checked="" type="checkbox"/> No / Non <input type="checkbox"/> Yes / Oui
6. Indicate the type of access required / Indiquer le type d'accès requis	
6. a) Will the supplier and its employees require access to PROTECTED and/or CLASSIFIED information or assets? / Le fournisseur ainsi que les employés auront-ils accès à des renseignements ou à des biens PROTÉGÉS et/ou CLASSIFIÉS? (Specify the level of access using the chart in Question 7. c) / (Préciser le niveau d'accès en utilisant le tableau qui se trouve à la question 7. c)	<input checked="" type="checkbox"/> No / Non <input type="checkbox"/> Yes / Oui
6. b) Will the supplier and its employees (e.g. cleaners, maintenance personnel) require access to restricted access areas? No access to PROTECTED and/or CLASSIFIED information or assets is permitted. / Le fournisseur et ses employés (p. ex. nettoyeurs, personnel d'entretien) auront-ils accès à des zones d'accès restreintes? L'accès à des renseignements ou à des biens PROTÉGÉS et/ou CLASSIFIÉS n'est pas autorisé.	<input type="checkbox"/> No / Non <input checked="" type="checkbox"/> Yes / Oui
6. c) Is this a commercial courier or delivery requirement with no overnight storage? / S'agit-il d'un contrat de messagerie ou de livraison commerciale sans entreposage de nuit?	<input checked="" type="checkbox"/> No / Non <input type="checkbox"/> Yes / Oui
7. a) Indicate the type of information that the supplier will be required to access / Indiquer le type d'information auquel le fournisseur devra avoir accès	
Canada <input checked="" type="checkbox"/>	NATO / OTAN <input type="checkbox"/>
Foreign / Étranger <input type="checkbox"/>	
7. b) Release restrictions / Restrictions relatives à la diffusion	No release restrictions / Aucune restriction relative à la diffusion <input checked="" type="checkbox"/>
Not releasable / À ne pas diffuser <input type="checkbox"/>	All NATO countries / Tous les pays de l'OTAN <input type="checkbox"/>
Restricted to / Limité à : <input type="checkbox"/>	Restricted to / Limité à : <input type="checkbox"/>
Specify country(ies) : / Préciser le(s) pays :	Specify country(ies) : / Préciser le(s) pays :
7. c) Level of Information / Niveau d'information	
PROTECTED A / PROTÉGÉ A <input type="checkbox"/>	NATO UNCLASSIFIED / NATO NON CLASSIFIÉ <input type="checkbox"/>
PROTECTED B / PROTÉGÉ B <input type="checkbox"/>	NATO RESTRICTED / NATO DIFFUSION RESTREINTE <input type="checkbox"/>
PROTECTED C / PROTÉGÉ C <input type="checkbox"/>	NATO CONFIDENTIAL / NATO CONFIDENTIEL <input type="checkbox"/>
CONFIDENTIAL / CONFIDENTIEL <input type="checkbox"/>	NATO SECRET / NATO SECRET <input type="checkbox"/>
SECRET / SECRET <input type="checkbox"/>	COSMIC TOP SECRET / COSMIC "TRÈS SECRET" <input type="checkbox"/>
TOP SECRET / TRÈS SECRET <input type="checkbox"/>	PROTECTED A / PROTÉGÉ A <input type="checkbox"/>
TOP SECRET (S/GINT) / TRÈS SECRET (SIGINT) <input type="checkbox"/>	PROTECTED B / PROTÉGÉ B <input type="checkbox"/>
	PROTECTED C / PROTÉGÉ C <input type="checkbox"/>
	CONFIDENTIAL / CONFIDENTIEL <input type="checkbox"/>
	SECRET / SECRET <input type="checkbox"/>
	TOP SECRET / TRÈS SECRET <input type="checkbox"/>
	TOP SECRET (SIGINT) / TRÈS SECRET (SIGINT) <input type="checkbox"/>

TBS/SCT 350-103/2004(12)

Security Classification / Classification de sécurité





Annex "H" INTEGRITY FORM - BIDDER'S INFORMATION

As per the new Integrity Regime within the Federal Government the following information is required from all vendors prior to contract award.

Certifications Precedent to Contract Award and Additional Information

The certifications and additional information listed below should be submitted with the quote but may be submitted afterwards. If any of these required certifications or additional information is not completed and submitted as requested, the Contracting Authority will inform the vendor of a time frame within which to provide the information. Failure to provide the certifications or the additional information listed below within the time frame specified will render the quote to be non-responsive.

Integrity Provisions – Required Documentation

In accordance with the Ineligibility and Suspension Policy (http://www.tpsgc-pwgsc.gc.ca/ci-if/politique-policy-eng.html), the Vendor must provide the required documentation, as applicable, to be given further consideration in the procurement process.

Individual Corporation Joint Venture (with checkboxes)

Legal Business Name: _____

Alternate Name: _____ (Name that your company is operating under if different from Legal Business Name.)

Telephone Number: _____

Address: _____

City/Province: _____

Postal Code: _____

Fax Number: _____

E-mail Address: _____

GST or Business # _____

The entire BN or GST has 15 characters. (ex: 123456789 RT0001)

If no GST or Business #, provide your SIN # _____

Complete list of name(s) of Board of Directors or Owners, as applicable:

Table with 2 columns: Complete Name, Please indicate if they are a Board of Director or Owner.



Annex "I"
BID SUBMISSION CHECKLIST

Bids must be submitted only to RCMP Bid Receiving Unit by the date, time and place indicated on page 1 of the bid solicitation.

Procurement & Contracting Services
c/o Commissionaires, F Division
6101 Dewdney Ave
Regina, SK S4P 3K7

or

Fax # 306-780-5232

Ensure the following pages are completed in full and attached:

- Front Page of Invitation to Tender document – signed & dated
- Front Page of Amendment document(s) (if applicable) – signed & dated
- Annex "B" Certifications
- Annex "D" Basis of Payment – must be completed in full (all tables)
- Annex "H" Bidder's Information

Ensure you include all costs of doing business in your bid price.
(*Including insurance requirements – Annex "C")



Annex “J”
Corflex Operable Partitions
(attached at the end of this document)

Corflex

OPERABLE PARTITIONS

Operation & maintenance Manual



5600 Series
Individual
Panels

10 Poissant street (Quebec) J5B 2J1
T: 450.444.2422 F: 450.444.2441
1 877.410.2422 info@corflex.ca
www.corflex.ca

Omni-directional panels

5600 Series - Top & Bottom retractable seals

Available STC ratings: 54, 53, 52, 51, 50, 49, 47, 43, 41, 38

- Steel trim with beige, brown, grey or black Powder coated finish
- Manual operation
- Retractable seals at top and bottom of panels
- Omni-directional

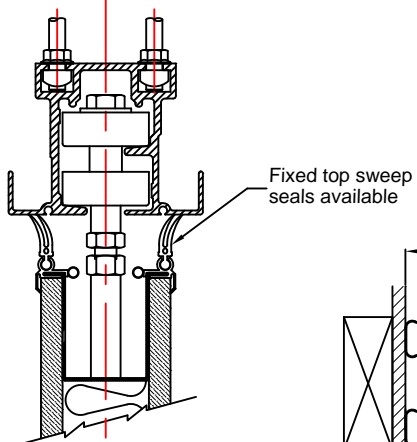
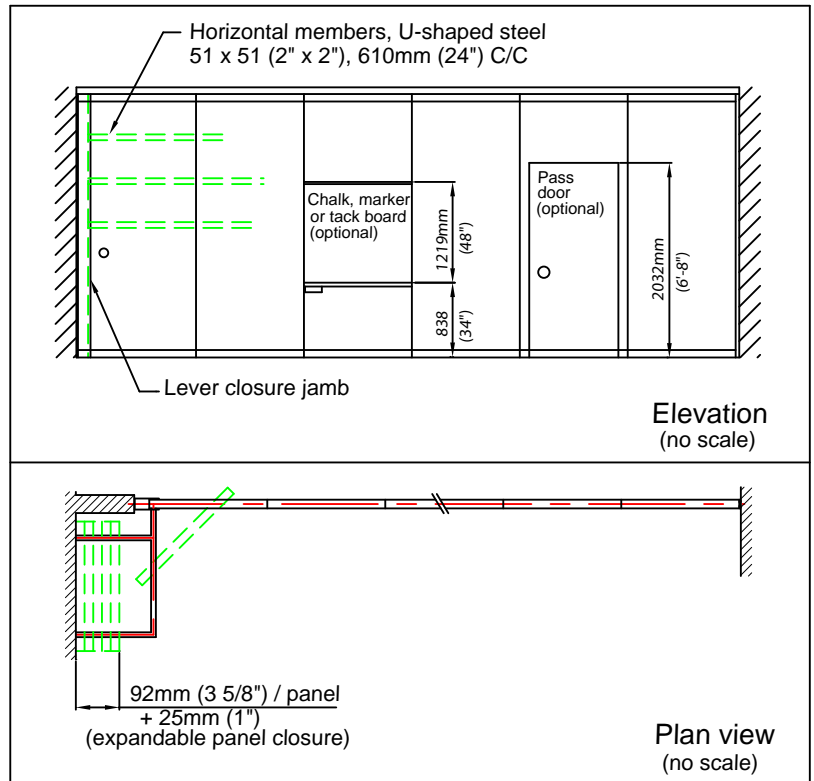
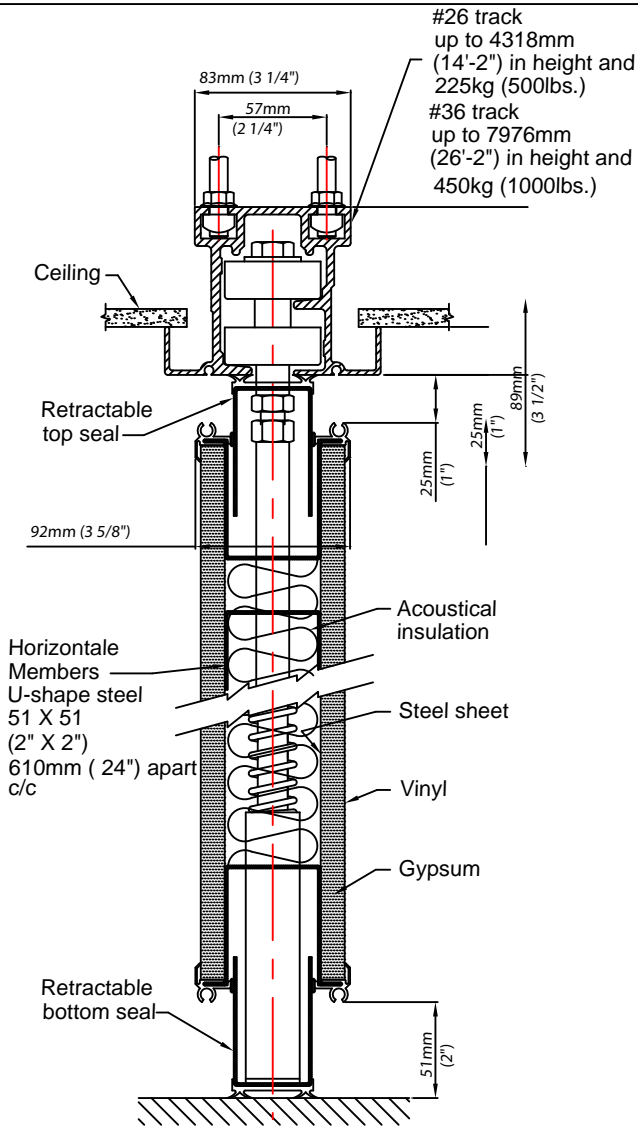

Expandable panel closure

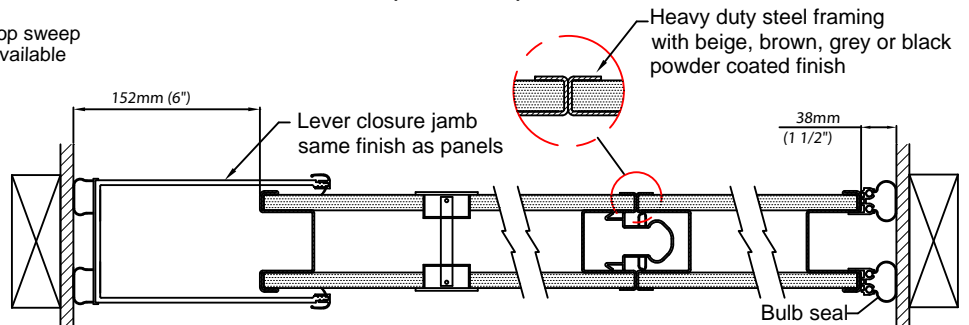

Hinged panel closure

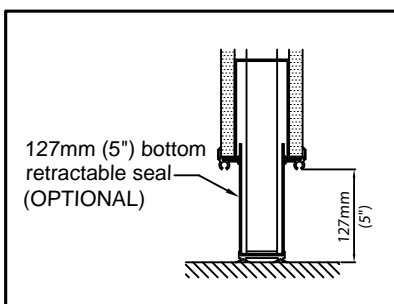
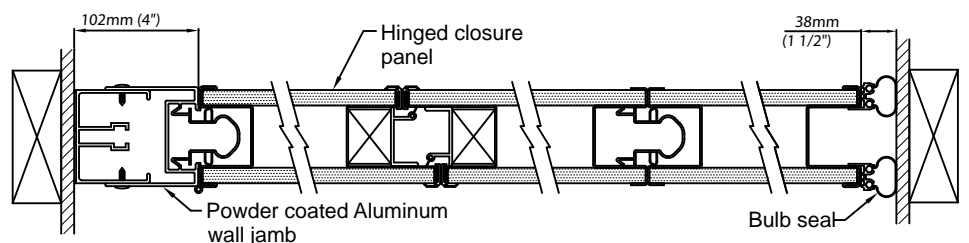

MAINTENANCE AND OPERATION GUIDE

5600 Serie

Operation

Partitions with Hinged Closure Panel

1. Gently slide out 1st panel from stack bundle into main track (Fig.1)
2. Gently push panel to far end opposite to stack (Fig. 2)
3. Place operating handle into trail end of panel and turn half revolution to lock top and bottom mechanical seals (Fig.3)
4. Repeat steps 1 to 3 with remaining panels
5. When all panels are in line across room and seals are locked, swing hinged closure panel to closed position in line with all panels (Fig. 4)
6. To stack folding partition, reverse above steps from 5 to 1

Partitions with Lever Closure Panel

1. Gently slide out 1st panel from stack bundle into main track (Fig.1)
2. Gently push panel to far end opposite to stack (Fig. 2)
3. Place operating handle into trail end of panel and turn half revolution to lock top and bottom mechanical seals (Fig.3)
4. Repeat steps 1 to 3 with remaining panels
5. If the partition includes a pass-through door with a top mechanical seal, the seal must be activated both on the inside jamb of the pass-through door as well as on the edge of the panel
6. When all panels are in line across room and seals are locked, gently slide out lever closure panel from stack to main track
7. Gently push lever closure panel against last panel
8. Place operating handle into trail end of panel and turn half revolution to lock top and bottom mechanical seals
9. Place operating handle into opening on face of panel and turn to expand nose against wall to seal folding partition (Fig. 4)
10. To stack folding partition, reverse above steps from 8 to 1

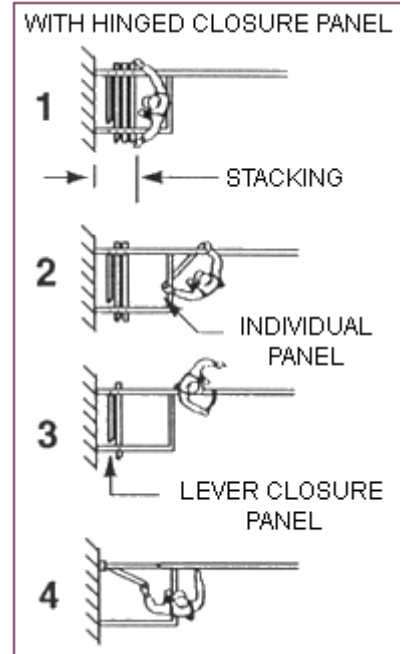

Maintenance

After installation, this folding partition requires very little maintenance.

1. Should some roughness develop in the supporting track when moving the panels, wipe off the inside of the bottom lips of the track on both levels with a rag. When clean, apply a small quantity of light grease to these lips at intervals across the full opening and stacking area.

Operate the panels across the opening to evenly distribute the grease along the track.

2. If it is necessary to clean the fabric, use warm water and soap, with a soft scrubbing brush. Avoid chemical cleaners or strong detergents.

See following page for detailed cleaning instructions.

3. Should replacement parts be required, or for other information, contact your nearest Corflex distributor.

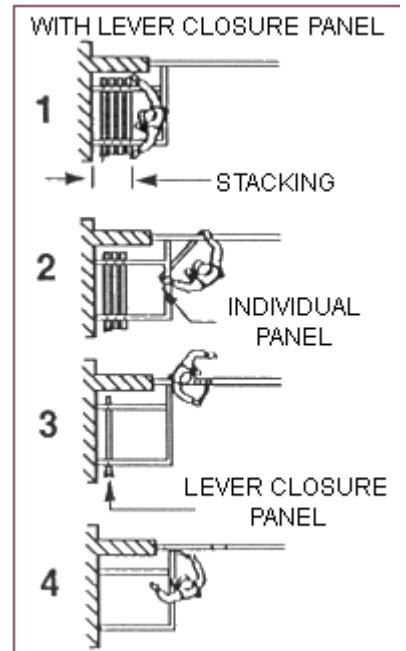

CLEANING INSTRUCTION

**These instructions will serve as a guide to normal cleaning maintenance.
Always use the mildest cleaning method first before using chemical cleaners.**

Fabric

Depending upon the extent of soilage, use traditional methods, i.e., washing, wiping, vacuuming. If promptly treated, most indelible stains can be removed by using undiluted chlorine bleach (Clorox) or selected cleaning agents with no damaging effects.

Vinyl

Stains should be removed as quickly as possible to eliminate any possible reaction between the staining agent and the wallcovering. Time is especially important for removing materials containing colors or solvents, such as ballpoint ink, lipstick, oil and some food-stuffs. If soiled materials remain on the wallcovering too long, permanent discoloration may develop.

NOTE : When using rubbing alcohol, hydrogen peroxide, turpentine, household bleach or kerosene, first test the solution on some inconspicuous portion of the vinyl to be sure that there will not be any adverse effect on print, color or gloss. When drying always use a blotting action rather than a rubbing motion.

NEVER MIX CLEANING AGENTS TOGETHER – VIOLENT REACTIONS MAY OCCUR

Vinyl wallcoverings should not be sprayed with wax or other protective coating. Such application would only tend to discolour the material, and in any case, would offer little protection.

Day-to-Day Soil

Ordinary dirt and smudges can be removed with a mild soap, warm water, and if necessary, a hard bristle brush to remove dirt from the crevices of deeply textured patterns. Clean from bottom of wall upward. Rinse thoroughly with clean water from the top down using a sponge. Deeply embossed wallcoverings need extra attention in case suds or loosened dirt lodge in depressed surfaces. Dry vinyl with a soft, white, lint-free cloth or towel. For more difficult stains that are only surface deep, the use of a stronger detergent is recommended however, the manufacturer's instructions should be followed carefully.

Not recommended for cleaning are steel wool or powdered abrasives because they mar the surface leaving an unsightly appearance. DO NOT use active solvent type cleaning preparations, such as nail polish remover, tar and bug remover, etc., because they remove print, and/or finish from the wallcovering.

Stains

- Ballpoint Ink :** Remove immediately using a cloth dampened in rubbing alcohol.
- Chewing gum, Grease :** Scrape off as much as possible and go over lightly with cleaning naphtha to remove remainder. (Chewing gum will come off more easily if rubbed with an ice cube) Rinse with clear water.
- Pencil, Crayon :** Scrape off excess crayon and erase pencil marks. Clean remaining stains with rubbing alcohol.
- Paint or Enamel :** Remove immediately with sponge or cloth dampened with turpentine, kerosene, cleaning naphtha or water as directed by paint can label. Wash with mild soap and water. Rinse with clear water.
- Lacquer, Shellac :** Remove immediately with dry cloth, taking care not to spread stain. Clean quickly with rubbing alcohol or perchlorethylene (Technical Grade). Rinse with clear water.
- Tar or asphalt :** Remove immediately using a cloth dampened with kerosene or cleaning naphtha. Rub gently from outside edge of stain to center to prevent stain from spreading. Rinse with clear water.
- Blood, Urine :** Remove quickly using a strong soap solution.

Corflex

10 Poissant street (Quebec) J5B 2J1
T: 450.444.2422 F: 450.444.2441
1 877.410.2422 info@corflex.ca
www.corflex.ca