



Fisheries and Oceans
Canada

Pêches et Océans
Canada

Canadian
Coast Guard

Garde côtière
canadienne



**SOW – FOUNDATIONS AND NEW RANGE
OSHAWA HARBOUR
OSHAWA, ON**

MARITIME AND CIVIL INFRASTRUCTURE

Prepared by: BB

Approved by: BY

Revision: 0

File: EWA 8010-20-503

Rev Date: March 6, 2017



TABLE OF CONTENTS

SECTION:	011100 GENERAL INSTRUCTIONS	1
SECTION:	013300 SUBMITTAL PROCEDURES	7
SECTION:	013530 HEALTH AND SAFETY REQUIREMENTS	8
SECTION:	013543 ENVIRONMENTAL PROCEDURES	9
SECTION:	014500 QUALITY ASSURANCE AND CONTROL	13
SECTION:	016100 COMMON PRODUCT REQUIREMENTS	15
SECTION:	024116 DEMOLITION	17
SECTION:	033000 CONCRETE WORK	20
SECTION:	133613 METAL TOWERS	26
SECTION:	310000 EARTHWORK	31



SECTION: 011100 GENERAL INSTRUCTIONS

PART 1 - GENERAL

1.1 Minimum Standards

- .1 Perform work in accordance with National Building Code of Canada (NBC) and any other code of provincial or local application. In the case of any conflict or discrepancy, the more stringent requirements shall apply.
 - .1 Meet or exceed requirements of:
 - .1 Contract documents;
 - .2 Specified standards, codes and referenced documents.

1.2 Description of Work

- .1 Work under this contract includes, but is not limited to, the provision of all labour, materials, and equipment required to:
 - .1 Procure surveyor to complete layout;
 - .2 Design, supply and install foundations for two [2] new AtoN (Aid to Navigation) towers using provided geotechnical report and capable of supporting the associated load as determined by the project engineer;
 - .3 Design and construct a culvert style entrance into the site and gravel access-way running to both new AtoN tower locations;
 - .4 Fabricate two [2] AtoN towers using supplied drawings in Appendix B3;
 - .5 Transport two [2] AtoN towers to the site;
 - .6 Erect the new AtoN towers, including all appurtenances;
 - .7 Pick up day-marks and associated hardware from CCG and install on new towers;
 - .8 Remove to grade and dispose of the existing rear range;
 - .9 Execute close-cut clearing to establish visibility corridor;
 - .10 Restoration as necessary; and,
 - .11 Erect and maintain any and all measures required to complete the works in consideration of the reasonably anticipated weather conditions during the construction period.



.2 Work excludes:

- .1 Installation of lanterns and associated equipment.
- .2 Fabrication of lanterns, day-marks and associated equipment.

1.3 Site Location

.1 The sites are new construction and are located as follows:

- .1 Oshawa Harbour – 1350 Farewell St, Oshawa, Ontario L1H 6N8
- .2 Site is located within Oshawa, Ontario.
- .3 The approximate coordinates of the site are 43°52'12.00"N, 78°49'35.00"W. The survey is included in Appendix B3.

1.4 Submittals

.1 Mandatory submittals and schedule for submission are detailed below and in Appendix B2. The following identifies general requirements only. The relevant sections must be consulted for a complete listing of mandatory content.

.2 Detailed Schedule:

.1 Deadline:

- .1 No later than twenty [20] working days following award.

.2 Deliverables:

.1 The Contractor shall furnish a high level schedule outlining:

.1 Anticipated start and finish dates of the project, including:

- .1 Design of the concrete foundations;
- .2 Fabrication of the AtoN tower assemblies
- .3 Site entrance and laneway construction;
- .4 Foundation installation (including any curing period);
- .5 Tower erection; and,
- .6 Demolition of the existing tower.

.2 Proposed submission dates for:

- .1 Design package; and,
- .2 Construction plan.



- .3 Anticipated onsite periods (preliminary investigations, material staging, construction)
- .3 The schedule is to be updated and revised as necessary throughout the duration of the project upon reasonable request of the CCG Project Authority [PA].
- .3 Project participant listing:
 - .1 Deadline: With detailed schedule
 - .2 Deliverables:
 - .1 Identification of Project Manager,
 - .2 Identification of Project Engineer,
 - .3 Identification of pertinent subcontractors.
- .4 Design Package
 - .1 Deadline
 - .1 No later than thirty [30] working days following award.
 - .2 Deliverables:
 - .1 Drawings stamped and signed by a qualified Professional Engineer registered in the Province of Ontario. Drawings to conform to all requirements outlined in Section 033000, Section 133613, and Section 310000.
- .5 Construction Plan:
 - .1 Deadline:
 - .1 As identified in the Contractor's schedule.
 - .2 No less than ten [10] working days prior to mobilization.
 - .2 Deliverables:
 - .1 A Construction Plan of sufficient detail to demonstrate that the Contractor has considered all the challenges of the project and is prepared to undertake the works in a competent and professional manner in accordance with all legislation, including:
 - .1 Contractor Qualifications (Section 011100 cl. 1.5), to include:
 - .1 Core Project member contact information (site foreman and project manager);
 - .2 Complete listing of all Subcontractors (especially tower fabricator);
 - .3 Proof of CWB certification for tower fabricator.
 - .2 Project specific safety program (Section 013530);



- .3 Project environmental protection plan (Section 013543);
 - .4 Detailed demolition plan (Section 024116);
 - .5 Concrete construction plan (Section 033000);
 - .6 Tower erection plan (Section 133613);
 - .7 Excavation construction procedures (Section 310000).
- .6 Maintenance Package
- .1 Deadline:
 - .1 21 calendar days following acceptance of the works
 - .2 Deliverables:
 - .1 As-built drawings
 - .2 Concrete test results
 - .3 Waste disposal receipts.
- 1.5 Contractor Qualifications
- .1 The work shall be carried out under the supervision and responsibility of a sole specialized Contractor.
 - .2 The Contractor must be experienced in the installation of aid to navigation structures or other similar free standing steel structures.
 - .3 The Contractor is to designate all key project members, including any subcontractors. The project members shall have completed projects of similar scope and complexity to the work described herein.
 - .1 Site Foreman: Contact information for the main point of contact at site shall be provided by the contractor.
 - .2 Project Manager: Contact information for the main point of contact for the project shall be provided by the contractor.
 - .3 Contractor's Engineer: The Contractor's Engineer shall be responsible for overseeing/stamping the work itemized below and must verify compliance with the contract specifications and all applicable codes.
 - .4 Tower Manufacturer: The Tower Manufacturer shall be responsible for the fabrication of the towers. Manufacturer must be certified by CWB to CSA standard W47.1, division 1 or 2.
 - .1 Certification: provide Canadian Welding Bureau (CWB) Certification



- .5 Requests to amend the project team, following contract award, must be forwarded in writing. Coast Guard reserves the right to reject any proposal to amend the project team.

1.6 Existing Conditions

- .1 Bidders must make their own estimate of the difficulties associated with all phases of the works.
- .2 The Contractor must include in their own costs all expenses related to the difficulties of working at the sites.
- .3 Photographs of the existing site are included in Appendix B1.
- .4 A geotechnical investigation has been completed for this location. A copy of the findings is provided in Appendix B4.

1.7 Contractor's Access to Site

- .1 Contractor is responsible for transportation of all labour, materials, and equipment to and from the sites, including any and all material furnished or itemized for salvage by Coast Guard.
- .2 The site is currently fenced off from Harbour Road.
- .3 Site Access must be arranged with consent from the Port Authority. Contact Jacqueline Lavine, 905-576-0400, info@portofshawa.ca. Afterwards, Coast Guard must be notified at least three [3] working days prior to any site access.

1.8 Completion, Scheduling and Planning of the Works

- .1 Work may commence as early as practical following CCG's acceptance and approval of mandatory submissions.
- .2 Site work shall not commence without written authorization of CCG PA.
- .3 Work shall be completed no later than October 31, 2017 unless otherwise negotiated and approved in writing by CCG PA and DFO Contract Authority.
- .4 Demolition of the existing tower shall not commence until the new towers are fully commissioned. The contractor shall allow for up to 3 weeks' time for the commissioning and acceptance of the new range.

1.9 Coast Guard Staging Location

- .1 Items itemized as supplied by, or salvaged to Coast Guard shall be collected or delivered by the Contractor to the following staging location. The Contractor shall be responsible for all transportation costs between the project site and the identified staging location. Material drop off or access to stored goods outside of regular operating hours shall be at the discretion of Coast Guard and may be subject to cost recovery.
 - .1 Staging Location: CCG Base – Prescott, 401 Queen St W, Prescott, ON, K0E 1T0
 - .2 Advise Coast Guard at least three [3] working days prior to pickup/delivery



- .1 Shipping/Receiving hours: Monday through Friday, 9:00AM to 3:00PM.

1.10 Temporary Facilities

- .1 Provide sanitary facilities for work force in accordance with governing regulations and ordinances.
- .2 Arrange, pay for, and maintain temporary electrical power supply as required for construction, and water supply as required, in accordance with governing regulations and ordinances.
- .3 Maintain emergency spills kit on-site at all times.

1.11 Fees, Permits, Certificates and Information

- .1 Contractor shall provide authorities having jurisdiction with all information requested.
 - .1 Contractor shall provide copies to CCG of any documentation submitted to other authorities related to the work described in this document.
 - .2 Contractor shall pay fees and obtain certificates and permits required.
 - .3 Contractor shall furnish certificates and permits when requested.

1.12 Reference Documents

- .1 The most recent publication or edition of any document referenced in this specification should be used unless the referencing clause states that this clause does not apply.

1.13 Required Submissions

- .1 A summary of the minimum mandatory submissions required can be found in Appendix B2. This summary is not an exhaustive list of all submissions required for the duration of the project. Additional submissions may be required after award.

PART 2 - PRODUCTS

- 2.1 Not Used

PART 3 - EXECUTION

- 3.1 Not Used



SECTION: 013300 SUBMITTAL PROCEDURES

PART 1 - GENERAL

1.1 General

- .1 This section specifies requirements and procedures for the Contractor's submissions of documents to CCG PA for review.
- .2 Do not proceed with the work until submitted documents or samples have been reviewed by CCG PA.
- .3 Where items or information is not produced in SI Metric units, converted values are acceptable.
- .4 Contractor's responsibility for errors and omissions in submission is not relieved by CCG PA's review of the submitted documents.
- .5 Notify CCG PA, in writing at time of submission, identifying deviations from requirements of Contract Documents stating reasons for deviations.
- .6 Contractor's responsibility for deviations in submission from requirements of Contract Documents is not relieved by CCG PA's review of submission, unless CCP PA gives written acceptance of specific deviations.
- .7 Make any changes to submissions that CCG PA may require consistent with Contract Documents and resubmit as directed by CCG PA.
- .8 Provide CCG PA with a written notice, when resubmitting, of any revisions other than those requested CCG PA.

1.2 Submission Requirements

- .1 Coordinate each submission with requirements of work and Contract Documents. Individual submissions will not be reviewed until all related information is available.
- .2 Allow at least three [3] working days, or as stipulated elsewhere in these specifications, for CCG PA to review the submission.
- .3 The Contractor's Engineer shall stamp and sign any submissions requiring a Professional Engineer's seal certifying his approval of samples, verification of field measurements, and compliance with Contract Documents.



SECTION: 013530 HEALTH AND SAFETY REQUIREMENTS

PART 1 - GENERAL

1.1 Scope

- .1 The Contractor shall be responsible to develop, implement and enforce a safety program which addresses all elements of the work performed at the project location, Oshawa Harbour.

1.2 References

- .1 Work under this section shall be undertaken in strict conformance with all listed references. In the case of any conflict or discrepancy, the more stringent requirements shall apply.
 - .1 Canada Labour Code Part II
 - .2 NRC-CNRC National Building Code of Canada
 - .3 Ontario Occupational Health and Safety Act and Regulations
 - .4 Any and all other Provincial/Territorial Regulations and Policies; Worker's Compensation Board Policies; Local municipal regulations; pertaining to safety of the Contractor's workers.

1.3 Submittals

- .1 Project Specific Safety Program

- .1 Deadline:

- .1 With Construction Plan

- .2 Deliverables:

- .1 Safety Program Document, include:

- .1 A listing of all activities specific to this phase of the project and their Health & Safety risks or hazards.
- .2 Detailed descriptions of how the activities are to be carried out as well as methods for mitigating hazards and risks.
- .3 A listing of personnel responsible for health and safety measures, and Emergency procedures.
- .4 Material Safety Data Sheets for hazardous products to be utilized in the execution of the works



SECTION: 013543 ENVIRONMENTAL PROCEDURES

PART 1 - GENERAL

1.1 Scope of Work

- .1 The Contractor must implement and enforce the following procedures throughout the duration of the work completed at the project location to mitigate potential negative impacts on the surrounding environment.

1.2 References

- .1 Work under this section shall be undertaken in strict conformance with all listed references. In the case of any conflict or discrepancy, the more stringent requirements shall apply.

- .1 Canadian Environmental Protection Act

1.3 Related Sections

- .1 Not used.

1.4 Submittals

- .1 Contractor shall submit an Environmental Protection Plan.

- .1 Deadline:

- .1 With Construction Plan

- .2 Deliverables:

- .1 Submit a plan addressing procedures to be implemented to mitigate any negative impact on the environment. Detail:

- .1 Equipment features (age, spill containment);
- .2 Staging, refueling, and cleaning areas;
- .3 Clean-up and/or containment procedures (including concrete/grout)
- .4 Waste disposal methods and sites; and,
- .5 Sedimentation control measures.

PART 2 - PRODUCTS

2.1 General

- .1 Avoid use of hazardous products. Use environmentally friendly products where practical.



PART 3 - EXECUTION

3.1 Construction Area

- .1 Confine construction activities to as small an area as practical.
- .2 Establish material storage, cleaning, and refueling areas where impacts to the surrounding environment will be negligible or readily mitigated.
- .3 Exclusionary silt fence shall be installed by May 1 to ensure turtles do not nest within construction area.

3.2 Stockpiling of Materials

- .1 Materials must be stockpiled as far from the shoreline as practical. Tarps must be used to control dust and run-off.
- .2 Stockpiled excavated materials shall be skirted using filter fabric to control run-off of fines during rain.

3.3 Disposal of Wastes

- .1 Clean-up the site at the end of each working day.
- .2 All waste material to be disposed of in a legal manner at a site approved by local authorities. Transporter/hauler must be appropriately licensed.
 - .1 Recycle or reuse materials where possible.
- .3 Fires and burning of rubbish on site is not permitted.
- .4 Do not bury rubbish and waste materials on site.

3.4 Clearing and Grubbing

- .1 Only clear vegetation that interferes with construction.
- .2 Vegetation clearing shall occur outside of breeding bird season, April 1 to July 31.

3.5 Drainage

- .1 Provide temporary drainage and pumping as necessary to keep excavations and site free from water.
 - .1 Suspend works during periods of heavy rainfall and add temporary covers to discourage run-off.
 - .2 Water pumped from excavation shall be adequately treated to ensure that water returning to the watercourse contains minimal fines. Procedures anticipated for preventing the pumping of fines shall be identified in the environmental protection plan, and may include the following:



- .1 Use of filter bags;
- .2 Straw bale check dams or silt fence;
- .3 Discharge through naturally occurring vegetation.
- .3 The means for controlling silt run-off shall be dependent on the site and the quantity of water pumped, and shall be to the discretion of the CCG site staff.
- .4 Sedimentation control measures shall be inspected and improved/cleaned/replaced as necessary.

3.6 Pollution Control

- .1 Provide methods, means, and facilities to prevent the contamination of soil, water, and atmosphere from the discharge of pollutants produced by construction operations.
- .2 Vehicles, machinery, and equipment shall be in good repair, equipped with emission controls as applicable and operated within regulatory requirements.
- .3 Abide by local noise by-laws.
- .4 Avoid unnecessary idling of vehicles or heavy machinery.
- .5 Limit use of equipment around the shoreline where possible.
- .6 Implement and maintain dust and particulate control measures in accordance with provincial requirements:
 - .1 All bulk material haul equipment shall be appropriately tarped. Watertight vehicles shall be used to haul wet materials.
 - .7 Designate a cleaning area for tools to limit water use and runoff. Do not allow deleterious materials to enter waterways. Ensure emptied containers are sealed and stored safely for disposal.
 - .8 The Contractor shall take all necessary precautions to guard against the release of any noxious substance or pollutant to the environment. In the event of any spill the Contractor shall take immediate action to control the release and mitigate any impact.
- .1 Materials and equipment to intercept, contain, and clean-up any spill or other release shall be maintained on site throughout the construction period and must be readily accessible at all times.
- .2 Any uncontrolled release of a known contaminant (spills, fire/smoke) shall be reported to appropriate Provincial Authority and CCG. Spills of deleterious substances to be immediately contained and cleaned up in accordance with provincial regulatory requirements.
- .3 Provincial Authority: Ontario Spills Action Centre 1-800-268-6060



Fisheries and Oceans
Canada

Pêches et Océans
Canada

Canadian
Coast Guard

Garde côtière
canadienne



3.7 Traffic

- .1 Minimize soil compaction by driving, parking vehicles, and walking, etc. on existing paved roadways/laneways. If soil is impacted by compaction, compensate by restoring areas with new soil, as required.
- .2 Avoid the use of heavy machinery in areas of sensitive slopes. Avoid using machinery on land during wet weather.



SECTION: 014500 QUALITY ASSURANCE AND CONTROL

PART 1 - GENERAL

1.1 Inspection

- .1 CCG PA or their representative shall have access to the work at all times. If parts of the work are prepared off-site or in a shop, access shall be given to such work throughout the duration of the project.
- .2 In the event the work must be submitted to special testing, inspection or approvals prescribed by these specifications or provided for in work-site regulations, the request for inspection must be made without unreasonable delay.
- .3 The below list identifies key milestones where the Canadian Coast Guard will require an opportunity to take samples/inspect:
 - .1 Subgrade verification: CCG will inspect the subgrade upon completion of the excavation.
 - .2 Concrete testing: CCG will test concrete for air, slump, and strength during the pour.
 - .3 Final completion: CCG will conduct a final inspection upon completion. This will include the commissioning of the lantern equipment.

1.2 Procedures

- .1 Provide CCG PA with advance notice whenever testing is required in accordance with these specifications, so that all parties involved can be present.
- .2 Provide necessary manpower and installations for obtaining and handling samples and material on site.
- .3 Provide access to site if the site is of remote nature whereby the Contractor is responsible for providing access to the site.

1.3 Rejected Work

- .1 Remove defective work, whether incorporated into the work or not, which has been rejected by CCG PA as failing to comply with the contract documents. Replace or re-execute in accordance with the Contract Documents.

1.4 Tests and Mixture Formulas

- .1 Supply test reports and required mixture formulas.

1.5 Factory Tests

- .1 Submit test certificates as prescribed in the relevant section of the specifications.



Fisheries and Oceans
Canada

Pêches et Océans
Canada

Canadian
Coast Guard

Garde côtière
canadienne



1.6 Acceptance of Work

- .1 CCG PA will make acceptance visits of work executed by the Contractor at the critical milestones identified in the following sections.
- .2 The Contractor is to inform CCG PA at least three [3] working days before achieving these milestones to allow time for inspection to be coordinated.
- .3 All work shall be completed in compliance with these specifications before requesting inspection. If the work is not completed or deemed non-compliant, the Contractor shall be responsible for all costs incurred for subsequent inspections.



SECTION: 016100 COMMON PRODUCT REQUIREMENTS

PART 1 - GENERAL

1.1 General

- .1 Secure CCG PA's approval of all products to be incorporated into the works. Work shall not commence until product data and/or samples have received written approval.
- .2 Supply and/or fabricate material and equipment of prescribed quality, with performance conforming to these specifications, references and industry standards.
- .3 Use new material and equipment unless otherwise specified.
- .4 Ensure replacement parts may be readily procured.
- .5 Use products from one manufacturer for material and equipment of same type or classification, unless otherwise specified.

1.2 Manufacturer's Instructions

- .1 Unless otherwise specified, comply with manufacturer's latest printed instructions for materials and installation methods.
- .2 Notify CCG PA in writing of any conflict between these specifications and manufacturer's instructions; CCG PA will designate which document is to be followed.

1.3 Compliance

- .1 When material or equipment is specified by standard or performance specifications, upon request of CCG PA, obtain an independent testing laboratory report from the manufacturer, stating that material or equipment meets or exceeds specified requirements.

1.4 Substitution

- .1 Where specific products have been specified, proposals for substitution may only be submitted after award of contract. Such requests must include statements of respective costs of items originally specified and the proposed substitution.
- .2 No substitutions will be permitted without prior written approval of CCG PA. substitutions will be considered by CCG PA only when:
 - .1 Materials specified in Contract Documents are not available; or,
 - .2 Delivery date of materials selected from those materials specified would unduly delay completion of contract; or,
 - .3 Alternative materials to those specified which are brought to the attention of, and are considered by CCG PA as equivalent to the material specified. Where the value of such materials is less than the material specified, the difference is to be credited from the Contract amount.



Fisheries and Oceans
Canada

Pêches et Océans
Canada

Canadian
Coast Guard

Garde côtière
canadienne



- .3 Should the proposed substitution be accepted either in whole, or in part, the Contractor must assume full responsibility and costs when such substitution affects other work on the project including any and all design or drawing changes required as a result of substitution.

1.5 Submittals

- .1 Provide product specifications and/or samples upon request from CCG PA.



SECTION: 024116 DEMOLITION

PART 1 - GENERAL

1.1 Scope of Work

- .1 Work under this section consists of the provision of all labour, materials, and equipment necessary to:
 - .1 Remove and dispose of the existing rear range;
 - .2 Remove foundation of existing range to grade;
 - .3 Disposal of all waste at a licensed waste disposal facility.

1.2 References

- .1 Work under this section shall be undertaken in strict conformance with all listed references. In the case of any conflict or discrepancy, the more stringent requirements shall apply.
 - .1 Canada Labour Code Part II
 - .2 NRC-CNRC National Building Code of Canada
 - .3 Ontario Occupational Health and Safety Act
 - .4 CSA S350-[M2980(R1998)], Code of Practiced Safety in Demolition of Structures

1.3 Submittals

- .1 Contractor to provide demolition plan.
 - .1 Deadline:
 - .1 With Construction Plan.
 - .2 Deliverables:
 - .1 Method of demolition including all associated tasks and schedule;
 - .2 Methods for protecting the site from demolition debris.
 - .3 The ultimate disposal location of all waste materials and debris.
 - .1 Include documentation detailing regulatory approval for waste disposal facility and transporter
- .2 Work under this section shall not proceed until written approval of the demolition plan has been received from the Coast Guard.



- .3 Submit copies of certified receipts from the disposal sites for all materials removed from the work site upon request.

1.4 Existing Conditions

- .1 Existing range has reached its life expectancy. Contractor must insure the range is dismantled and demolished in a safe manner.

- .1 Photos of the existing range are included in Appendix B1.

PART 2 - PRODUCTS

- 2.1 Not Used

PART 3 - EXECUTION

3.1 General

- .1 Work under this section shall be continuous and proceed without interruption unless otherwise approved by Coast Guard.
- .2 Towers shall be dismantled in place. Towers shall not be felled without the specific authorization of Coast Guard.
- .3 Demolition work shall not commence until the Canadian Coast Guard has verified and commissioned the new range and associated equipment. The contractor shall allow for a full day after tower erection for the light commissioning work.

3.2 Protection

- .1 Prevent movement, settlement or damage of adjacent structures/vegetation.
- .2 Implement effective controls to catch/collect all tower debris during demolition, specifically paint.
- .3 Implement effective controls to prevent injury to workers, mariners, motorists, and pedestrians.

3.3 Preparation

- .1 Erect warning signs and barricades.
- .2 Ensure all environmental protection/mitigation measures are in place.
- .3 Ensure facilities have been de-energized.
- .4 Ensure all items identified for salvage have been removed and stored.

3.4 Demolition

- .1 Demolish existing steel structures in their entirety.



Fisheries and Oceans
Canada

Pêches et Océans
Canada

Canadian
Coast Guard

Garde côtière
canadienne



- .2 Demolish foundations flush to grade. Any concrete piers, anchor bolts or other protruding members shall be cut flush to grade.
- .3 Ensure that demolition does not adversely affect adjacent watercourses, groundwater and wildlife, or contribute to excess air and noise pollution.
- .4 Ensure demolition is undertaken safely. If at any period during demolition the safety of the Contractor's staff cannot be maintained, take preventative measures, stop work and notify Coast Guard.

3.5 Disposal

- .1 All material is to be disposed of off-site at a licensed disposal/recycling facility.

3.6 Restoration

- .1 The site in its entirety must be restored to an equal or greater condition after completion of construction.



SECTION: 033000 CONCRETE WORK

PART 1 - GENERAL

1.1 Scope of Work

- .1 Work of this section includes the supply of all labour, material, and equipment, necessary to complete the following:
 - .1 Design and install two [2] suitable reinforced concrete foundations to support the towers (Section 133613)
 - .1 Design must be completed in consideration of the geotechnical report included in Appendix B4
 - .2 Foundations must be designed to resist all anticipated dead and live loads, provided by the project engineer
 - .2 Installation of bearing grout between completed foundation and tower base/anchor plate
 - .3 Any and all provisions necessary to ensure that the anticipated performance of the placed concrete will be obtained if work is undertaken in cold weather.

1.2 References

- .1 Work under this section shall be undertaken in strict conformance with all listed references. In the case of any conflict or discrepancy, the more stringent requirements shall apply.
 - .1 Canada Labour Code Part II
 - .2 NRC-CNRC National Building Code of Canada
 - .3 Ontario Occupational Health and Safety Act and Regulations
 - .4 CAN/CSA A23.1 Concrete Materials and Methods of Concrete Construction
 - .5 CAN/CSA A23.2 Methods of Test and Standard Practices for Concrete
 - .6 CAN/CSA-G30.18 Billet Steel Bars for Concrete Reinforcement
 - .7 CAN/CSA S269.3 Concrete Formwork
 - .8 ACI Specification 306 Cold Weather Concreting (if relevant)

1.3 Performance Requirements

- .1 The foundation shall be designed to perform as would be reasonable expected for a life of fifty [50] years.



1.4 Submittals

- .1 The following submittals are to be provided to the CCG PA:
- .2 Foundation Design:
 - .1 Deadline: with Construction Plan
 - .2 Deliverables:
 - .1 Engineered drawings stamped and signed by an engineer licensed to practice in the Province of Ontario
 - .1 Drawings must detail:
 - .1 Plan, elevation and relevant section views of the proposed installation;
 - .2 Any pertinent commentary concerning construction of the proposed foundation and anchorage element of the proposed facility
 - .2 Summary Report.(if necessary)
 - .1 The summary report shall contain all additional technical references and requirements not otherwise detailed within the engineered drawings.
- .3 Concrete Placement Plan:
 - .1 Deadline:
 - .1 With Construction Plan
 - .2 Deliverables:
 - .1 Provide high level summary of mix properties and admixtures to demonstrate compliance with CCG criteria and completed foundation design;
 - .2 Provide MSDS, (pre-mixed products only).
 - .3 Concrete placement methods and curing procedures, detail:
 - .1 Source of concrete, including mix plan;
 - .2 Shop drawings for formwork and false-work;
 - .3 Placement methods and procedures to control consolidation/segregation;
 - .4 Location of necessary cold joints;
 - .5 Finishing procedures;
 - .6 Mill test certificates for rebar, piles or any other steel used in the foundations;



- .7 Curing methods and schedule;
 - .8 Strength requirements for structural stability (removal of forms);
 - .9 Clean-up procedures;
 - .10 Mitigation measures to account for hot or cold temperatures where reasonably anticipated during the construction period.
- .4 Maintenance Package
- .1 Deadline:
 - .1 No later than 21 days following contract award
 - .2 Deliverables:
 - .1 Contractor to provide concrete test results demonstrating sufficiency of concrete to engineer's specification.
- .5 As-built and Quality Control
- .1 Deadline:
 - .1 28 days following completion of construction activities
 - .2 Deliverables:
 - .1 Red-lined drawings showing all changes from the sealed design drawings (if any);
 - .2 Confirmation of subgrade verification;
 - .3 Concrete test results.
- 1.5 Quality Assurance
- .1 CCG's minimum inspection requirements are detailed below. The Contractor shall be responsible to notify CCG of the date and time that the works may be inspected. Notice must be provided no less than three [3] working days in advance to permit scheduling of quality assurance testing. All deficiencies in the works identified at the time of inspection shall be remedied to the satisfaction of CCG, by the Contractor at their expense. Work shall not progress until inspections have been completed and the Contractor has been provided with written notice to proceed with the works.
 - .1 Upon completion of formwork and placement of reinforcement.
 - .2 During execution of concrete placement.
 - .2 The Contractor shall be responsible to arrange for concrete testing on site the day of the pour. This shall include at minimum a test for slump, air entrainment and strength (three [3] cylinders, one [1] 7-day, and two [2] 28-day).



- .1 Extra concrete cylinders shall be cast and broken to determine foundation strength prior to tower erection. This will be coordinated by CCG staff upon request from the Contractor.
- .2 Testing is to be completed by a third-party independent Consultant and is to be completed by a certified technician in accordance with CSA Code A23.2.

PART 2 - MATERIALS

2.1 General

- .1 All materials shall conform to requirements of CAN/CSA-A23.1.

2.2 Formwork

- .1 Shall be in accordance with CAN/CSA S269.3

2.3 Concrete

- .1 Concrete shall possess the minimum characteristic detailed in the Contract Drawings.
- .1 For clarity, concrete employed may be commercially available pre-batched and prepackaged mix or locally available ready-mix concrete.

2.4 Water

- .1 Water utilized for the production concrete must be potable, unless otherwise approved in writing by CCG PA.

2.5 Reinforcement

- .1 Shall be as detailed in the submitted foundation design
- .2 Reinforcing steel must be as mandated in CAN/CSA A23.1
 - .1 Grade 400W unless otherwise identified in the Contract Drawings.
 - .1 All bars shall be deformed, uncoated unless otherwise identified in the Contract Drawings.
- .3 Bar supports must be as mandated in CAN/CSA A23.1, 6.6.7.2.

PART 3 - EXECUTION

3.1 General

- .1 Concrete must be placed, finished, and cured in accordance with the Contractor's submitted construction plan.
- .1 Ensure that the top of the concrete is no less than 150mm (6in) above the surrounding grade, unless otherwise approved in writing.



- .2 Installation shall be undertaken in accordance with the Contractor's engineered drawings and accompanying materials as contained in the Contractor's Summary Report.
- .3 Locations shall be in conformance with surveyed positions detailed in Appendix B3. Installation of the towers and foundations must not disturb the integrity of the existing facilities or the continued operation of the existing light station.

3.2 Design

- .1 Design shall be completed in conjunction with the engineered geotechnical investigation and shall be overseen by a qualified Professional Engineer licensed to practice in Ontario, with a minimum of five [5] years' experience in foundation design.
- .2 Design shall clearly identify the location and use of the foundation.
- .3 Design shall clearly identify all climactic loads used in the design of the foundations. The foundations shall be designed to resist all loads specified in the National Building Code of Canada, 2005, and the User's Guide – NBC 2005 Structural Commentaries (Part 4), as well as maximum dead loads caused by all equipment installed in or on the towers as described in these specifications and plans.
- .4 Design shall include any material or construction specification deemed important to the design engineer.
- .5 Exposed edges must be chamfered.

3.3 Preparation

- .1 Preparation shall not commence until bearing surfaces have been inspected by CCG PA.
- .2 Remove all loose and deleterious material.
- .3 Construct forms as detailed in the submitted construction plan.
- .4 Place reinforcement in accordance with Contract Drawings.
- .5 If the rebar cage as detailed is not strong enough to maintain the designed shape, the contractor is responsible for installing additional reinforcement to keep the cage in shape during construction.
- .1 The cage must be adequately supported to carry the weight of a worker, if the contractor intends on walking on the rebar.
- .6 Concrete cover must be as indicated in the Contractor's approved foundation drawings.

3.4 Placement

- .1 Concrete placement shall not commence until formwork and reinforcement have been inspected by CCG PA.
- .2 Contractor shall place finish and cure concrete as per CAN/CSA A23.1 making all adjustments necessary to account for climatic conditions anticipated during the curing period.



- .3 Concrete shall be placed in one continuous pour.
 - .1 The development of cold joints shall be avoided. Alternatively, cold joints must be previously approved in writing by CCG.
- .4 Finish exposed concrete surfaces to provide a lightly brushed non-skid surface.
- .5 Cut control joints where specified.
- .6 Contractor shall provide samples as required during placement operation for the performance of quality assurance testing.
- .7 Concrete shall be finished so as to slope gently away from the center of the slab. No water shall pond on the finished surface.
- .8 All exposed 90° edges shall be chamfered.

3.5 Curing

- .1 Shall be undertaken in accordance with CAN/CSA A23.1 and the Contractor's approved Construction Plan.
 - .1 Curing regimen employed must take into account local climatic conditions reasonably anticipated to occur during the curing period.

3.6 Grout

- .1 Supply and install load bearing grout between the top of the completed foundation and the tower base/anchor plate.
 - .1 Edges of grout shall be chamfered.



SECTION: 133613 METAL TOWERS

PART 1 - GENERAL

1.1 Scope of Work

- .1 Work under this section includes the supply of all labour, material, and equipment required to complete:
 - .1 Fabrication of two [2] new metal aid to navigation (AtoN) towers as detailed in Appendix B3, complete with:
 - .1 Working platform c/w cotterman gate, and one D-Ring,
 - .2 Lantern mount,
 - .3 Climbing system, including fixed ladder, fall arrest system, and anti-climb system
 - .2 Transportation of the tower and all associated hardware to site from the designated staging area;
 - .3 The installation of the tower detailed in the appended Contract Drawings;
 - .4 Transportation to site of the navigational day-mark;
 - .5 The installation of the navigational day-mark.
- .2 Work of this section excludes:
 - .1 Supply of the navigational day-mark and lanterns, and associated hardware, by CCG.

1.2 References

- .1 Work under this section shall be undertaken in strict conformance with all listed references. In the case of any conflict or discrepancy, the more stringent requirements shall apply.
 - .1 Canada Labour Code Part II
 - .2 NRC-CNRC National Building Code of Canada
 - .3 CSA S37-01 – Antenna Towers and Antenna Supporting Structures
 - .4 CAN/CSA S16.1 – Limit States Design of Steel Structures
 - .5 CAN/CSA G164 – Hot Dip Galvanizing of Irregularly Shaped Articles

1.3 Submittals

- .1 Submittals shall be forwarded to Coast Guard in accordance with the provisions of section 013530.



- .1 Erection Plan:
 - .1 Deadline:
 - .1 With Construction Plan.
 - .2 Deliverables:
 - .1 Plan must clearly demonstrate procedures and methods to be employed to:
 - .1 Erect the tower;
 - .2 Monitor that turn of nut has been completed;
 - .3 Field remedies to address any damage to the coating system incurred during transportation and erection;
 - .4 Contractor shall submit a shop drawing of the anti-climb that they propose to supply;
 - .5 CCG reserves the right to request additional documentation verifying the suitability of the proposed labour and equipment anticipated to be employed in the erection of the tower. Certification required may include:
 - .1 Crane/helicopter capacity.
 - .3 As-Built Drawings:
 - .1 Deadline:
 - .1 With maintenance plan.
 - .2 Deliverables:
 - .1 A complete set of as-built drawings detailing any and all amendments or revisions to the previously submitted design drawings or documentation indicating final works are as detailed in design drawings.
 - .2 Provide one [1] electronic copy (.pdf) format or one [1] hard copy
 - .2 Mill sheets for the steel and proof of WCB certification.
- 1.4 Quality Assurance
- .1 Coast Guards minimum inspection requirements are detailed below. The Contractor shall be responsible to notify Coast Guard of the date and time that the works may be inspected. Notice must be provided no less than three [3] working days in advance to permit schedule of quality assurance testing. All deficiencies in the works identified at the time of inspection shall be remedied to the satisfaction of CCG, by the Contractor at their expense. Work shall not progress until the inspections have been completed and the Contractor has been provided with written notice to proceed with the works:



- .1 Prior to galvanization of fabrication
- .2 During erection to confirm turn of nut procedures are being followed.
- .3 Upon completion of the work after cleaning has been carried out;

PART 2 - PRODUCTS

2.1 Materials

.1 Steel:

- .1 As specified in the Contract Drawings.

.2 Coatings:

.1 Galvanizing:

- .1 All materials, structural steel, pipe and fittings, including bolts, nuts and washers shall be hot dip galvanized to the requirement of the National Building Code, CAN/CSA S16.1, and CSA-G164 and as otherwise specified herein.

.3 Bolts, Nuts, Washers:

- .1 As specified in Contract Drawings, and supplied by CCG.
- .2 Anchor bolts must be as indicated in the approved engineering drawings/construction plan, provided by the contractor.
 - .1 Anchor bolts must possess sufficient threaded length above the top of the foundation to allow configuration specified in above mentioned engineering drawings.

.4 Miscellaneous Materials:

.1 Fall Restraint System.

- .1 Tylon TSF Cougar Rail safety rail, supplied by CCG.

.2 Cotterman Gate:

- .1 Tower shall be supplied with a fully functioning, automatically closing Cotterman gate installed between the upper platform and the step-off platform.

- .1 Model AG2440SS – 24" – 40" stainless steel

.3 Anti-Climb System

- .1 Towers shall be equipped with an anti-climb system.
- .2 The contractor shall be responsible for developing a design and submitting drawings for the proposed anti-climb system for approval by the CCG.



- .3 Requirements of the proposed design include:
 - .1 Shall prevent climbers from using the bottom 10' of the ladder;
 - .2 A method of locking the anti-climb;
 - .3 A hinged operation for opening the anti-climb;
 - .4 All components must be hot-dip galvanized.
- .4 Base grout:
 - .1 Non shrink, gassing, cementitious grout.
 - .1 Sika M-Bed Standard, or equal.

PART 3 - EXECUTION

3.1 Design Requirements

- .1 Location shall be in conformance with surveyed positions detailed in Appendix B3. Installation of the towers and foundations must not disturb the integrity of the existing facilities or the continued operation of the existing light station.

3.2 Fabrication

- .1 Fabrication will be completed by the contractor. This will include everything shown on the drawing which comprises the tower.

3.3 Protective Coatings

- .1 Galvanizing:
 - .1 The tower and all hardware are hot-dip galvanized. The contractor shall be prepared to make repairs to the coating as needed.

3.4 Handling of Materials and Transportation

- .1 The Contractor shall take all necessary precautions to avoid damage to the tower members or to tower coating during transport, unloading, and erection. All components or damaged members shall be replaced to the satisfaction of CCG at the expense of the Contractor.
- .2 It is the responsibility of the Contractor to ensure that the tower sections, particularly the joints, are protected from bending and alignment damage.
- .3 The Contractor will be asked to identify how he would like the tower packaged for shipping shortly after award. This will be coordinated by CCG.

3.5 Site Preparation

- .1 Complete installation of all foundation elements prior to tower erection.



Fisheries and Oceans
Canada

Pêches et Océans
Canada

Canadian
Coast Guard

Garde côtière
canadienne



.2 Adjust supporting/levelling nuts to uniform elevation.

3.6 Erection

.1 Erect tower in accordance with submitted plan.

.2 Preserve the electrical continuity between all sections.

.3 Grout between tower base and prepared concrete foundation.

.4 All bolted connections shall be made following the turn of nut procedure.



SECTION: 310000 EARTHWORK

PART 1 - GENERAL

1.1 General

- .1 Work of this section includes the supply of all labour, materials and equipment required to complete:
 - .1 The excavation for the installation of tower base foundation, including:
 - .1 Stripping and stockpiling of existing topsoil or granular materials to expose subgrade;
 - .2 Backfilling of the excavation, including:
 - .1 Supply of all required materials;
 - .2 Placement and/or compaction of granular material.
 - .2 The restoration of all disturbed areas within the work site
 - .3 Clearing of vegetation to allow for a clear line of sight to the range
 - .4 Design and implementation of an access-way from Harbour Road to and connecting the towers
 - .1 Installation of a culvert style entrance into the property
 - .2 Placement of granular material as necessary to access towers

1.2 References

- .1 Work under this section shall be undertaken in strict conformance with all listed references. In the case of any conflict or discrepancy, the more stringent requirements shall apply.
 - .1 Canada Labour Code Part II
 - .2 NRC-CNRC National Building Code of Canada
 - .3 Ontario Occupational Health and Safety Act and Regulations
 - .4 CAN/CSA-A23.1-04 Concrete Materials and Methods of Concrete Construction
 - .5 Any and all other Provincial/Territorial Regulations and Policies; Worker's Compensation Board Policies; Local municipal regulations; pertaining to work of this section.

1.3 Submittals

- .1 Submittals shall be provided to CCG in accordance with the provisions of section 013530.
 - .1 Construction Procedures:



.1 Deadline: with Construction Plan.

.2 Deliverables:

.1 Written Plan: Excavation and backfill procedures detail:

- .1 Proposed side slopes and control measures
- .2 Dewatering measures, if necessary
- .3 Measures to be taken to prevent exposed soils from freezing
- .4 Stockpile locations and methods for controlling erosion
- .5 Backfill placement: document equipment and procedures. Provide methods for undertaking backfill placement in cold weather, if reasonably anticipated
- .6 Include shop drawings of any shoring or bracing required. Drawings must be stamped by a licensed professional engineer
- .7 Access point creation proposal, including relevant permits for curb and fence alteration from all pertinent authorities

.1 Proposal shall include for culvert crossing, removal of existing fence, installation of new gate, and creation of a graveled path suitable for standard motor vehicles.

.2 Culvert Crossing Design Package:

.1 Deadline: with Construction Plan

.2 Deliverables:

.1 Engineered drawings stamped and signed by a professional engineer licensed to practice in Ontario

.1 Drawings must detail:

- .1 Plan, elevation and relevant section views of the proposed installation;
- .2 Any pertinent commentary concerning construction and installation of the culvert crossing and access way (materials, etc)

1.4 Existing Condition

- .1 A geotechnical investigation has been completed at this site and a copy of the report is included in Appendix B4.
- .2 Prior to commencing excavation, document the condition of all existing structures, landscaping, roadways, and other adjacent facilities anticipated to be impacted by the work.



.3 Before commencing work under this section, the Contractor must establish the location of all buried services that may interfere with the execution of work.

.4 All work of this section shall be witnessed by Coast Guard or its representative; unless permission is received in writing otherwise.

1.5 Quality Assurance

.1 CCG's minimum inspection requirements are detailed below. The Contractor shall be responsible to notify CCG of the date and time that the works may be inspected. Notice must be provided no less than three [3] working days in advance to permit scheduling of quality assurance testing. All deficiencies in the works identified at the time of inspection shall be remedied to the satisfaction of CCG, by the Contractor at their expense. Work shall not progress until inspections have been completed and the Contractor has been provided with written notice to proceed with the works.

.1 Bearing surfaces prior to backfill or formwork placement.

PART 2 - PRODUCTS

2.1 General

.1 All materials described in this section shall be supplied by the Contractor.

2.2 Water

.1 Shall be free of deleterious materials.

2.3 Backfill

.1 Backfill must consist of stockpiled native (excavated) materials.

.2 Backfill must not be frozen.

2.4 Granular Materials

.1 Shall be as per the approved design drawings.

2.5 Filter fabric

.1 Shall be as per the approved design drawings.

2.6 Culvert

.1 Shall be as per the approved design drawings.



PART 3 - EXECUTION

3.1 Site Preparation

- .1 Prior to commencing excavation, document the condition of all existing structures, landscaping, roadways, and other adjacent facilities anticipated to be impacted by the work.
- .2 Install any features required to protect existing infrastructure.

3.2 Excavation

- .1 Strip topsoil over areas impacted by new construction. Stockpile materials on-site
- .2 Side slopes must be maintained around the perimeter of the excavation in accordance with provincial legislation.
- .3 Take all reasonable precautions to minimize the disturbance of the existing vegetation.
- .4 Install measures as detailed in Construction Plan to prevent excavation from freezing.

3.3 Backfill

- .1 Ensure that surrounding soil is unfrozen or take measures to thaw frozen materials.
- .2 Backfill to be placed in uniform lifts to a maximum depth of 0.2m (8") and compacted to 95% SPMDD.

3.4 Installation of the Culvert entrance

- .1 Culvert style entrance into the property shall be installed as per the approved design drawings.
- .2 Contractor shall ensure that the do not negatively affect the:
 - .1 Backfill around new foundation;
 - .2 Spread remaining soils on site to the discretion of the CCG staff representative on-site

3.5 Installation of filter fabric and/or granular for the laneway.

- .1 After subgrade has been excavated and is clear of all deleterious or undesirable material the contractor shall lay down the filter fabric as per the design drawings.
- .2 Filter fabric shall be installed as per manufacturer's instructions.
- .3 There shall be no gaps or rips in the cloth.
- .4 Granular materials shall be installed in lifts as specified in the contract documents and each lift shall be compacted as specified.



3.6 Restoration

- .1 Restore all disturbed areas within work area and along haul routes. Fill and grade all ruts. Ensure positive drainage away from completed and existing foundations.
- .2 Excavated materials shall not be removed from site, but shall be used given the following priority:
 - .1 Backfill around new foundation;
 - .2 Spread remaining soils on site to the discretion of the CCG staff representative on-site.

3.7 Brushing

- .1 Clear property on range line to a height of vegetation not greater than 6".
 - .1 No grubbing is required
 - .2 The area of work will extend from around the base of the rear tower to the water's edge and shall be approximately 45m wide and 200m long.
 - .1 See attached survey in Appendix B3 for brushing lines.
 - .2 CCG staff will work with the Contractor to identify the area to be cleared.
- .3 Chip all brushed or felled material on site. Alternatively the Contractor may transport all material offsite, to a licensed recycling/disposal facility.



Fisheries and Oceans
Canada

Pêches et Océans
Canada

Canadian
Coast Guard

Garde côtière
canadienne



APPENDIX B1 – SITE LOCATION AND PHOTOGRAPHS



Fisheries and Oceans
Canada

Pêches et Océans
Canada

Canadian
Coast Guard

Garde côtière
canadienne

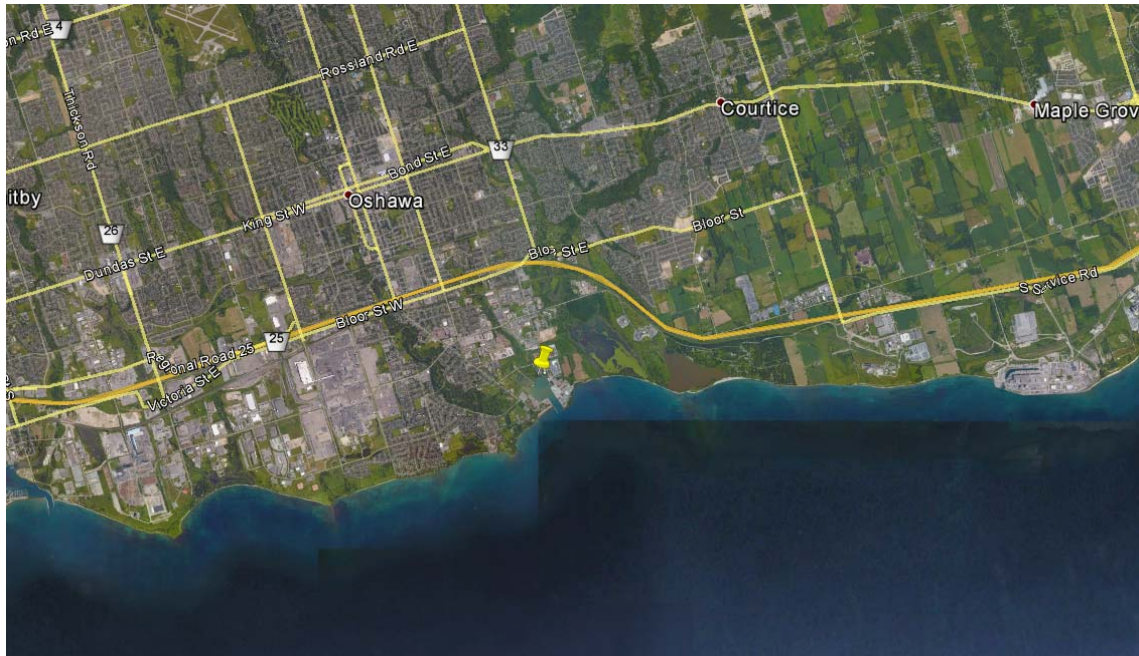

Figure 1: Project Site
Oshawa Harbour Proposed Range
43°52'12"N - 78°49'35"W



Figure 2: Project Site



Fisheries and Oceans
Canada

Pêches et Océans
Canada

Canadian
Coast Guard

Garde côtière
canadienne

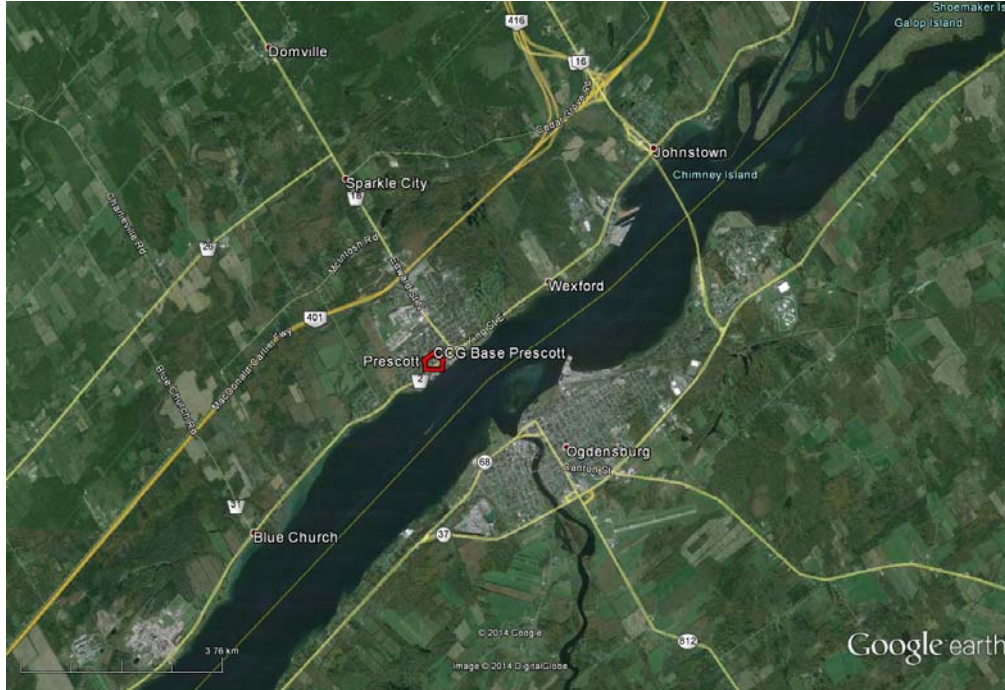

Figure 3: Coast Guard Staging Area
CCG Base Prescott
401 King Street West Prescott, ON K0E 1T0
44°42'23.16"N - 75°31'3.22"W

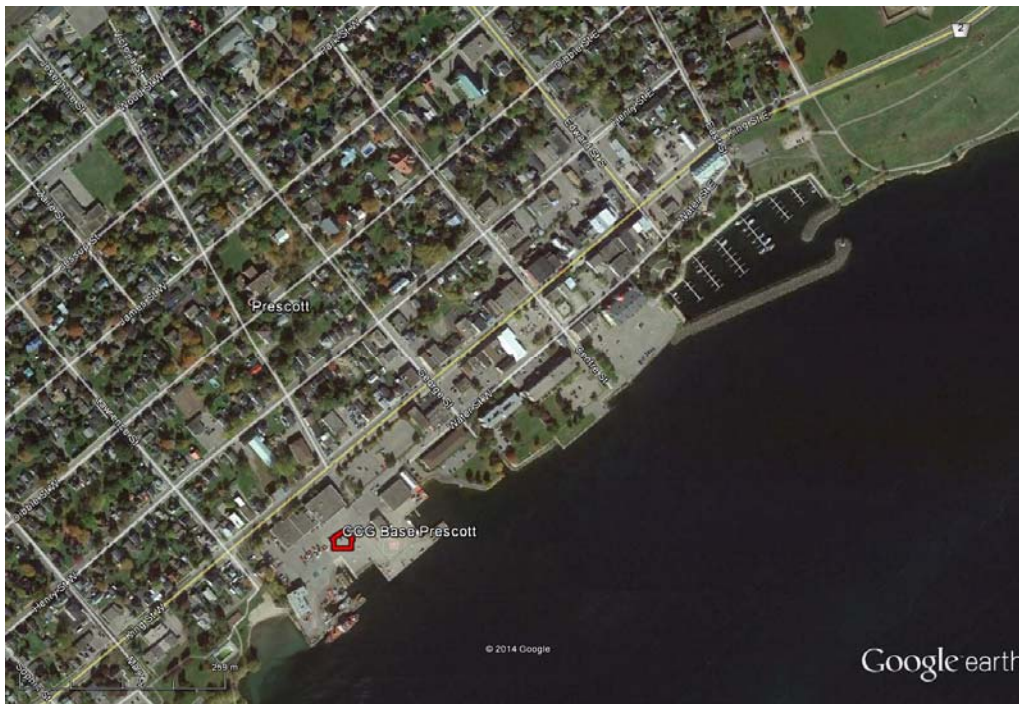

Figure 4: Coast Guard Staging Area



Fisheries and Oceans
Canada

Pêches et Océans
Canada

Canadian
Coast Guard

Garde côtière
canadienne



Figure 5: Existing Tower to be Demolished



Fisheries and Oceans
Canada

Pêches et Océans
Canada

Canadian
Coast Guard

Garde côtière
canadienne



Figure 6: Approximate Site View
Looking from front range to rear range



Fisheries and Oceans
Canada

Pêches et Océans
Canada

Canadian
Coast Guard

Garde côtière
canadienne



APPENDIX B2 – SUMMARY OF CONTRACT SUBMITTALS



Fisheries and Oceans
Canada

Pêches et Océans
Canada

Canadian
Coast Guard

Garde côtière
canadienne



Following Contract Award	
Submission Description	Section(s)
Deadline: 30 working days following award	
Design Package:	033000, 310000
Deadline: 20 working days following award	
Detailed schedule: Project Participant listing:	011100
Deadline: 10 working days prior to mobilization	
Proof of registration with Ontario WSIB Construction Plan – Final Submission	
a) Complete listing of personnel (inc. subcontractors)	011100
b) Final project specific safety plan	013530
c) Project environmental protection program	013543
d) Detailed demolition plan	024116
e) Concrete construction plan (include Concrete Mix Parameters)	033000
f) Tower plan (including anti-climb shop drawings)	133613
Deadline: 21 calendar days following acceptance of the works	
Waste disposal receipts:	024116
As-built drawings:	133613, 033000
Concrete test results:	033000



Fisheries and Oceans
Canada

Pêches et Océans
Canada

Canadian
Coast Guard

Garde côtière
canadienne



APPENDIX B3 – DRAWINGS

HARBOUR ROAD
 PIN 16380 -- 0003



ELEVATIONS
 Elevations are geodetic and referred to City of Oshawa Bench Mark 67U020 and having a geodetic elevation of 76.145m.

BEARING NOTES
 Bearings are UTM Grid, derived from observed reference points A and B, by Real Time Network observations, UTM Zone 17, NAD83(CSR5)(2010).

DISTANCE NOTES - METRIC
 Distances and coordinates are in metres and can be converted to feet by dividing by 0.3048.

CONTOURS
 Contours shown hereon are drawn at 0.50 metre intervals.

SEE DETAIL 'A'

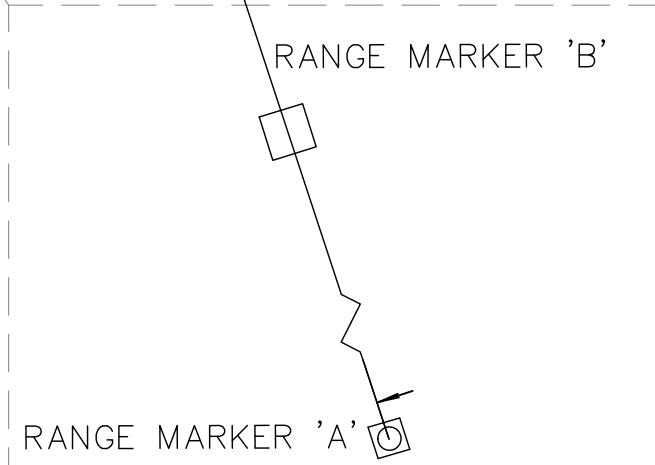
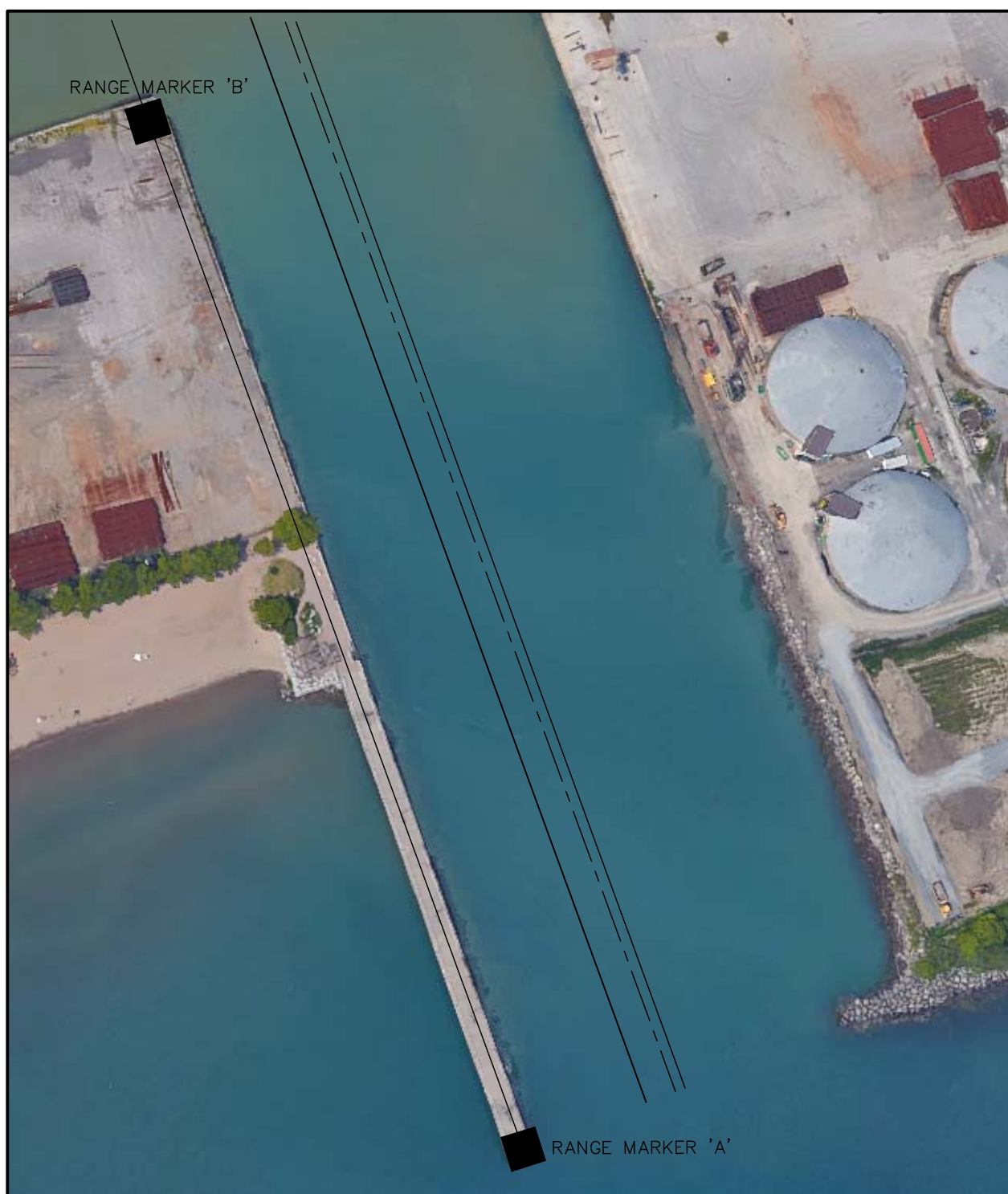

Services techniques
Systèmes électroniques et informatiques
Informations techniques et graphiques
101 Ave. Champlain, 1000 100
Québec (Québec) G1K 7H7

NOTES

- CAPACITÉ DE LA STRUCTURE AUX POINTS D'ANCRAGE =18 KN
- ANNEAUX DE SÉCURITÉ "D-RING":
- CAPACITÉ MAXIMALE = 140 kg.
- HAUTEUR DE CHUTE LIBRE MAXIMALE = 1.8m.
- JAMAIS PLUS D'UN SYSTÈME DE PROTECTION PERSONNEL À LA FOIS
- L'ÉCHELLE DOIT ÊTRE MUNIE D'UN RAIL DE SÉCURITÉ "MILLER SHURE TRACK" (OU UN ÉQUIVALENT APPROUVÉ PAR LA GCC) AVEC TOUTE LA QUINCAILLERIE REQUISE POUR SON INSTALLATION.
- NUANCE D'ACIER:
- TOUTS LES ÉLÉMENTS 300 Mpa SAUF LES ÉLÉMENTS SUIVANTS:
- LES CORNIÈRES: 350 Mpa
- LES PROFILS W: 350 Mpa
- TOUS LES BOULONS SELON ASTM A-325, TYPE 1.
- TOUTES LES RONDELLES DE BLOCAGE SELON ASME B18.21.1
- TOUS LES ESPACEURS ANNULAIRES SELON ANSI B18.22.1
- LONGUEUR DES BOULONS:
- 2" LG POUR BOULON 3/4", S.I.C.
- 1 1/2" LG POUR BOULON 1/2", S.I.C.
- TOUTES LES QUANTITÉS DE BOULON INCLUENT UN SURPLUS DE 5 %.
- CAPACITY OF THE STRUCTURE AT ANCHOR POINTS =18 KN
- SECURITY RINGS "D-RING":
- MAXIMUM CAPACITY = 140 kg.
- MAXIMUM FALLING HEIGHT = 1.8m.
- NEVER MORE THAN ONE PERSONAL SECURITY SYSTEM AT THE SAME TIME
- THE LADDER SHOULD BE EQUIPPED WITH A SAFETY RAIL "MILLER SHURE TRACK" MODEL 8631 (OR EQUIVALENT APPROVED BY CGC) WITH ALL HARDWARE REQUIRED FOR MOUNTING.
- STEEL GRADE:
- ALL MEMBERS 300 Mpa EXCEPT FOR:
- ANGLES: 350 Mpa
- W SHAPE: 350 Mpa
- ALL BOLTS ACCORDING TO ASTM A-325, TYPE 1.
- ALL LOCK WASHERS ACCORDING TO ASME B18.21.1
- ALL RING FILLS ACCORDING TO ANSI B18.22.1
- BOLT LENGTH:
- 2" LG FOR 3/4" BOLT, U.N.
- 1 1/2" LG FOR 1/2" BOLT, U.N.
- ALL BOLT QUANTITIES INCLUDE 5 % EXTRA.

△	MISE À JOUR	SLJ	2014.02.12
△	PIÈCES AJOUTÉES / ADDED MATERIAL	GCC	2010.11.30
2	NOTES CHANGÉES / NOTES CHANGED	M.V.	2008.03.23
1	M122 ADDED/M122 AJOUTÉ	M.V.	2008.03.13

Atteintes de détail

En fonction des besoins, les détails ont été réalisés à l'échelle 1:1.

En fonction des besoins, les détails ont été réalisés à l'échelle 1:1.

En fonction des besoins, les détails ont été réalisés à l'échelle 1:1.

Garde côtière, Région Laurentienne
Services Techniques
Systèmes électroniques et informatiques
Informations Techniques et Graphiques

TOUR D'ACIER À CLAIRE-VOIE
TOUR DE 3.05m (10pi) @ 24.2m (80pi)

TOUR DE 6.12m (20pi)
PLAN DE MONTAGE

P-C.GAGNON, Ing. 2003/05/30

MICHEL VACHON 2006/02/05

MICHEL VACHON 2006/02/05

1 = 40

BILL OF MATERIAL / LISTE DE MATÉRIEL			
MRK MQE	QTY QTE	DESCRIPTION DESCRIPTION	WEIGHT MASSE
M001		Parts were not ordered yet	
B002	4	BASE ASS./ASS. BASE	156.0
V010	4	L-76x76x9.5x3038	139.2
V012	4	L-76x76x9.5x3038	134.4
X022	26	L-76x76x7.9x1450	330.2
X023	3	FB-6.4x51x1525	12.0
X027	3	L-76x76x7.9x1525	40.2
H029	9	L-76x76x7.9x925	72.9
H030	3	L-76x76x7.9x925	24.3
H031	1	L-127x127x7.9x1049	16.6
H032	3	L-127x127x7.9x1049	49.8
P033	1	L-76x76x7.9x549	5.2
P034	1	L-76x76x7.9x1199	11.3
P035	1	L-76x76x7.9x1500	14.1
P036	1	L-76x76x7.9x2132	20.1
P045	1	L-76x76x7.9x909	8.6
P046	1	L-152x89x7.9x644	9.7
P047	1	L-76x76x7.9x909	8.6
P048	1	L-76x76x7.9x1033	9.7
P049	2	L-76x76x7.9x755	14.2
P050	1	L-51x51x6.4x1082	5.3
P051	1	L-51x51x6.4x1082	5.3
P052	1	L-51x51x6.4x644	3.2
P053	1	L-102x76x7.9x1499	16.6
P054	1	L-51x51x6.4x1179	5.8
P056	1	FB-6.4x102x2122	11.1
P057	2	FB-6.4x102x1179	12.4
P058	1	FB-6.4x102x539	2.8
P059	1	FB-6.4x51x2122	5.6
P060	1	FB-6.4x51x1179	3.1
P061	1	FB-6.4x51x644	1.7
P062	1	FB-6.4x51x539	1.4
P069	2	FB-9.5x127x270	4.2
P070			
P071			
P072			
P073			
P074			
P075			
P076			
P077			
P078			
E081	3	FB-6.4x51x259	2.7
E082	3	FB-6.4x51x508	3.9
M083	3	FB-6.4x51x377	3.0
E084	1	FB-6.4x51x315	0.8
E086	2	FB-6.4x51x259	1.4
E087	1	LADDER/ÉCHELLE#2915	31.7
E088	1	LADDER/ÉCHELLE#3035	32.3
P090	1	GRATING/CAIL. 548x1173	28.8
P091	1	GRATING/CAIL. 608x2110	57.5
E094	1	L-152.4x89x7.9x414	12.0
M100	4	FB-9.5x152x446	18.0
M101	6	FB-9.5x254x335	39.6
M102	7	FB-9.5x305x662	95.2
M103	16	FB-9.5x305x600	227.2
M108	1	PL-9.5x415x662	18.0
M119		Pre-fabricated door ordered, door parts were not ordered and can be ignored	
M120			
M121			
E123	10	FB-9.5x51x390	-
E124	8	FIXATION POUR BOITE	-
E125	2	FIXATION POUR CAPTEUR	-
A5	5	D-RING "SALA" #2101630	2.5
B5		Not ordered and can be ignored	
	4	S.S. BOLTS/BOULONS INOXYDABLES 3/16" X 3/4" WITH/WEC NUTS & WASH./ECROUS & ROND.	
	229	BOLTS/BOULONS 3/4" X 2"	62.3
	214	BOLTS/BOULONS 3/4" X 2 1/4"	61.9
	9	BOLTS/BOULONS 3/4" X 2 1/2"	2.7
	452	LOCK W./R. DE BLOCAGE 3/4"	13.4
	14	R. FILLS/ESPACEURS 3/4" X 9.5	1.3
	2	R. FILLS/ESPACEURS 3/4" X 7.9	0.2
	100	BOLTS/BOULONS 1/2" X 1 1/2"	9.0
	20	BOLTS/BOULONS 1/2" X 1 3/4"	1.9
	5	BOLTS/BOULONS 1/2" X 2"	0.5
	3	BOLTS/BOULONS 1/2" X 2 3/4"	0.4
	128	LOCK W./R. DE BLOCAGE 1/2"	1.2
	4	R. FILLS/ESPACEURS 1/2" X 7.9	0.2
	20	CLIPS/ATTACHES TYPE "D-19"	0.5
	20	BOLTS/BOULONS 5/16" X 2 1/2"	0.5
TOTAL WEIGHT / MASSE TOTALE :			1991.3 kg

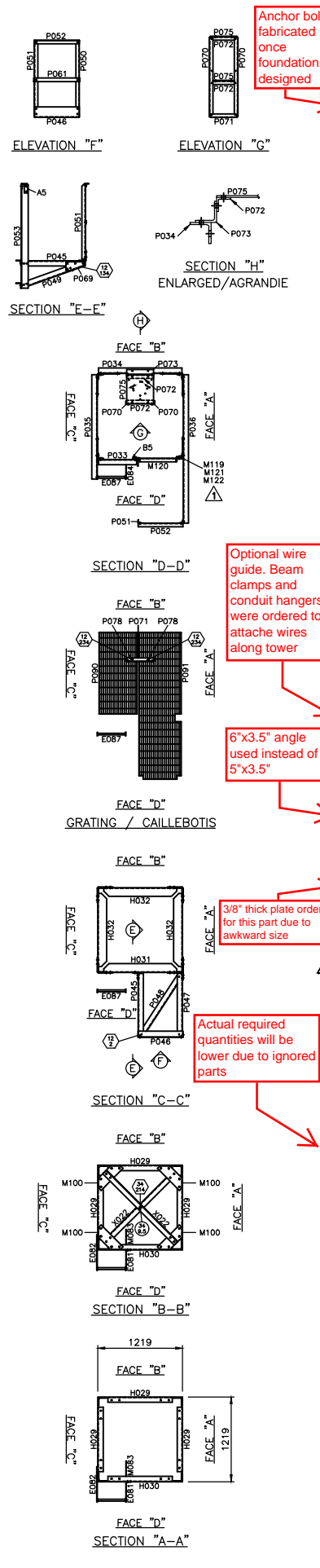
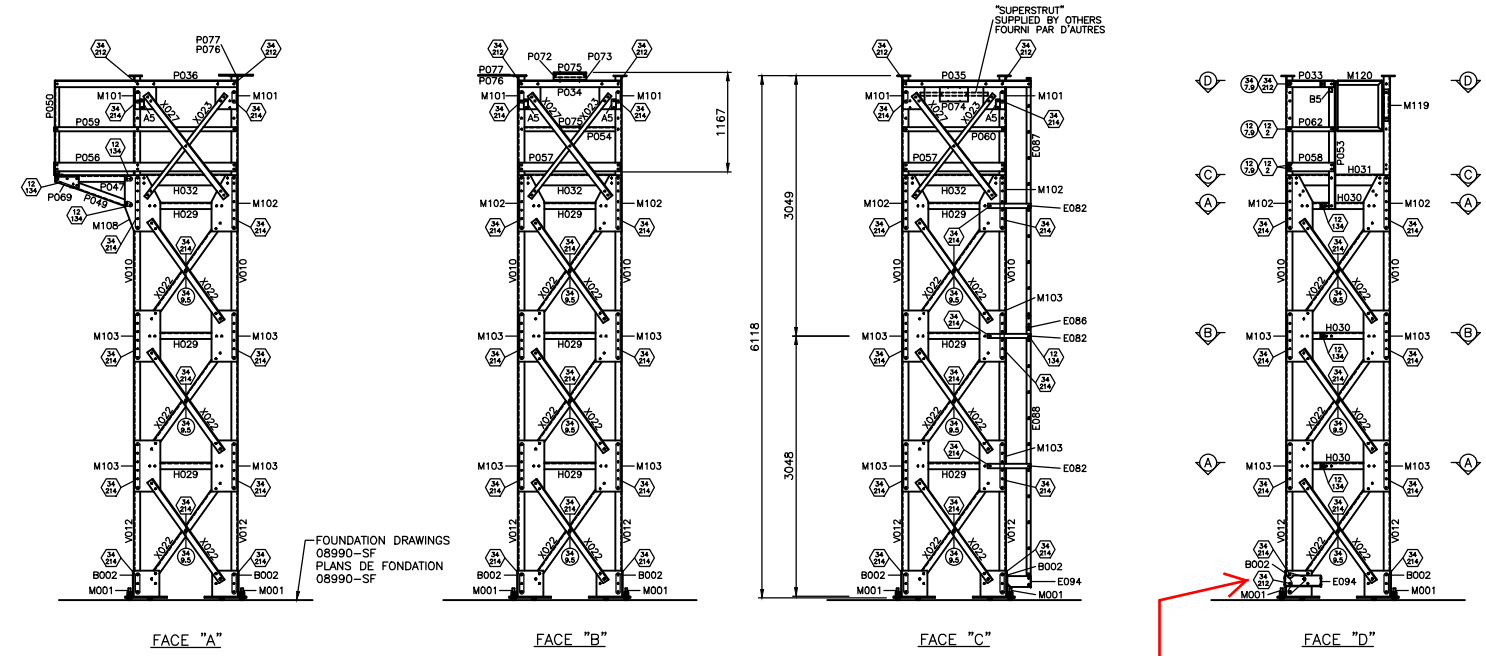

Ordered 5 of these extra long (2 3/4") bolts for this hole
NOTE: Anti-climb method yet to be chosen

Anchor bolts fabricated once foundation is designed

Optional wire guide. Beam clamps and conduit hangers were ordered to attach wires along tower

6"x3.5" angle used instead of 5"x3.5"

3/8" thick plate ordered for this part due to awkward size

Actual required quantities will be lower due to ignored parts

These parts make up the light support and swing stage support, they were not ordered and can be ignored

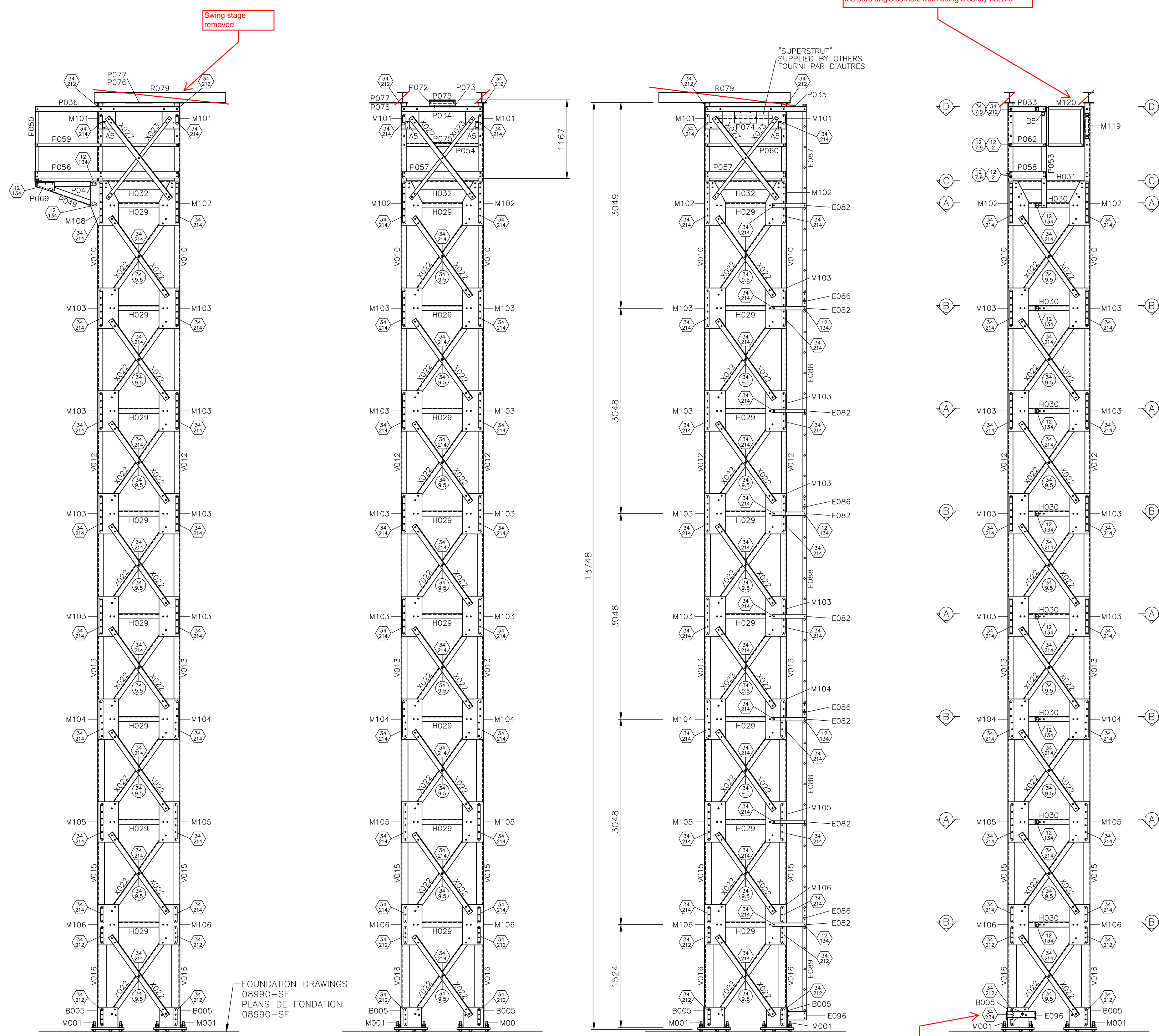

Swing stage removed

NOTE: The drawings for part V010 calls for a flat bar square to be welded to the top of the angle. Since no swing stage will be installed, this flat bar was not ordered and is not required, however the angles must be either shortened or covered in such a way to stop the bare angle corners from being a safety hazard.

Ordered 5 of these extra long (2'3/4") bolts for this hole
NOTE: Anti-climb method yet to be chosen

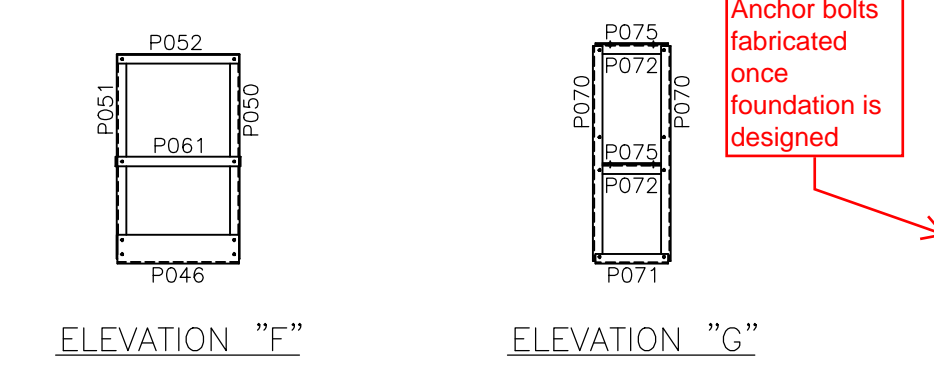

Anchor bolts fabricated once foundation is designed

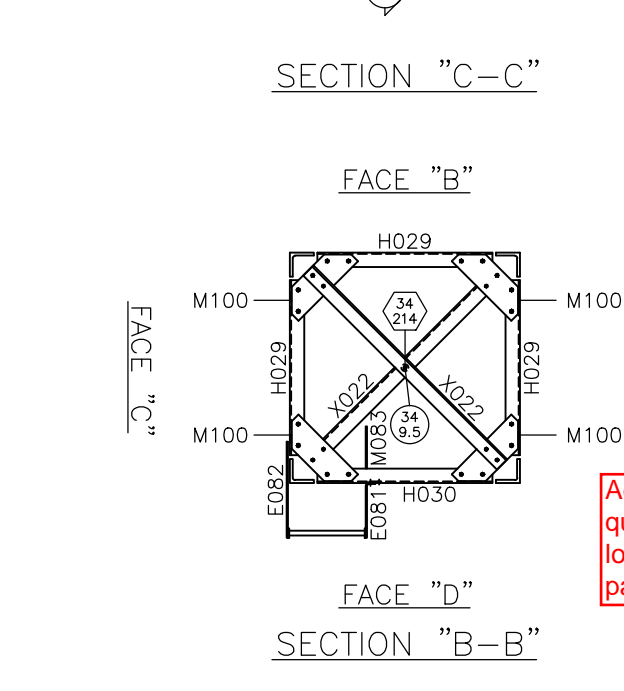
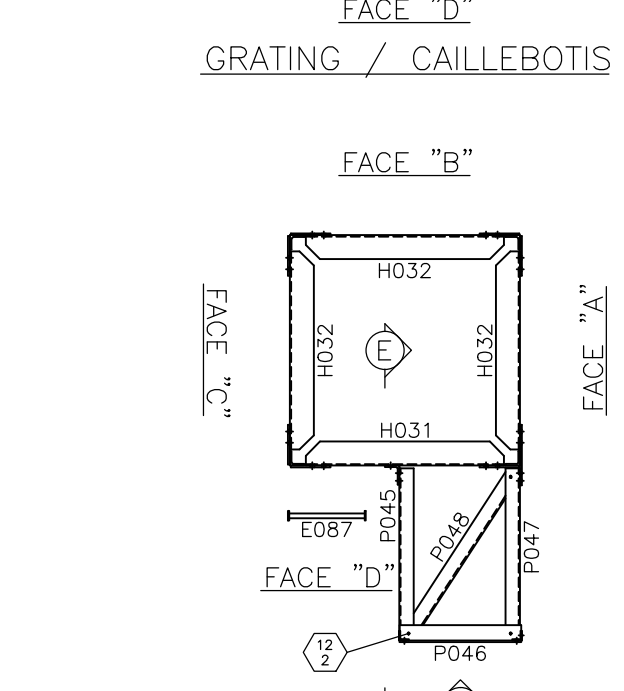
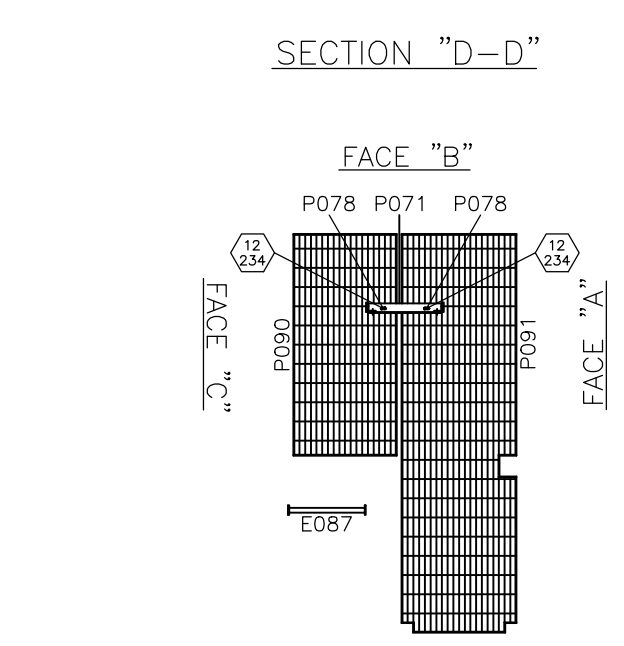
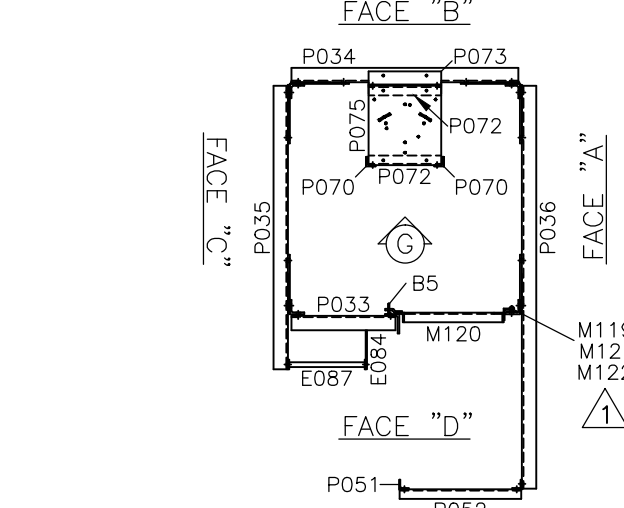
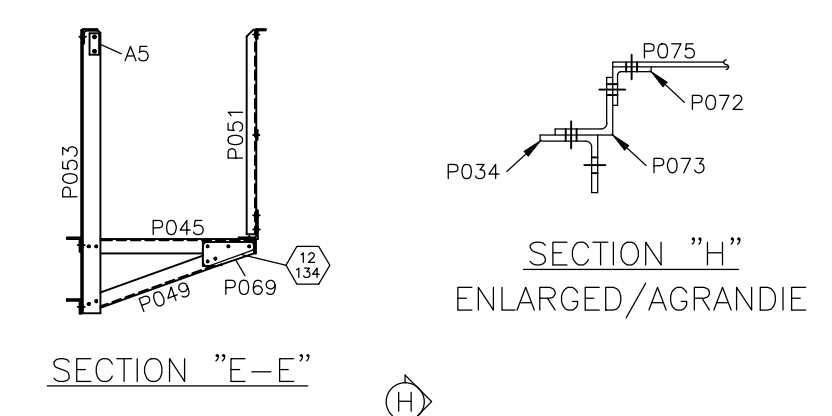

Optional wire guide. Beam clamps and conduit hangers were ordered to attach wires along tower

3/8" thick plate order for this part due to awkward size

Actual required quantities will be lower due to ignored parts

BILL OF MATERIAL / LISTE DE MATÉRIEL			
MRK	QTY	DESCRIPTION	WEIGHT
MQE	QTÉ	DESCRIPTION	MASSE
M001	16	Parts were not ordered yet	
B005	4	BASE ASS./ASS. BASE	215.2
V010	4	L-76x76x9.5x3038	139.2
V012	4	L-76x76x9.5x3038	134.4
V013	4	L-89x89x9.5x3038	158.4
V015	4	L-102x102x12.7x3038	240.0
V016	4	L-127x127x15.9x1514	240.0
X022	72	L-76x76x7.9x1450	914.4
X023	3	FB-6.4x51x1525	12.0
X027	3	L-76x76x7.9x1525	40.2
H029	24	L-76x76x7.9x925	194.4
H030	8	L-76x76x7.9x925	64.8
H031	1	L-127x127x7.9x1049	16.6
H032	3	L-127x127x7.9x1049	49.8
P033	1	L-76x76x7.9x949	5.2
P034	1	L-76x76x7.9x1199	11.3
P035	1	L-76x76x7.9x1500	14.1
P036	1	L-76x76x7.9x2132	20.1
P045	1	L-76x76x7.9x909	8.6
P046	1	L-152x89x7.9x644	9.7
P047	1	L-76x76x7.9x909	8.6
P048	1	L-76x76x7.9x1033	9.7
P049	2	L-76x76x7.9x755	14.2
P050	1	L-51x51x6.4x1082	5.3
P051	1	L-51x51x6.4x1082	5.3
P052	1	L-51x51x6.4x644	3.2
P053	1	L-102x76x7.9x1499	16.6
P054	1	L-51x51x6.4x1179	5.8
P056	1	FB-6.4x102x2122	11.1
P057	2	FB-6.4x102x1179	12.4
P058	1	FB-6.4x102x539	2.8
P059	1	FB-6.4x51x2122	5.6
P060	1	FB-6.4x51x1179	3.1
P061	1	FB-6.4x51x644	1.7
P062	1	FB-6.4x51x539	1.4
P069	2	FB-9.5x127x270	4.2
P070		These parts make up the light support and swing stage support, they were not ordered and can be ignored	
P071			
P072			
P073			
P074			
P075			
P076			
P077			
P078			
R079			
E081	8	FB-6.4x51x259	7.2
E082	8	FB-6.4x51x508	10.4
M083	8	FB-6.4x51x377	8.0
E084	1	FB-6.4x51x315	0.8
E086	8	FB-6.4x51x259	5.6
E087	1	LADDER/ÉCHELLEx2915	31.7
E088	3	LADDER/ÉCHELLEx3035	96.9
E089	1	LADDER/ÉCHELLEx1511	16.1
P090	1	GRATING/CAIL. 548x1173	28.8
P091	1	GRATING/CAIL. 608x2110	57.5
E096	1	L-127x89x7.9x414	10.9
M100	16	FB-9.5x152x446	72.0
M101	6	FB-9.5x254x335	39.6
M102	7	FB-9.5x305x510	95.2
M103	32	FB-9.5x305x600	454.4
M104	8	FB-9.5x305x600	113.6
M105	8	FB-9.5x305x600	113.6
M106	8	FB-9.5x305x600	113.6
M108	1	PL-9.5x415x662	18.0
M119	1		
M120	1	Pre-fabricated door ordered, door parts were not ordered and can be ignored	
M121	1		
M122	1		
E123	10	These parts were not ordered and can be ignored	
E124	8		
E125	2		
A5	5	D-RING "SALA" #2101630	2.5
B5	1	Not ordered and can be ignored	
	4	S.S. BOLTS/BOULONS INOXYDABLES 3/16" X 3/4" WITH/AVEC NUTS & WASH./ECROUS & ROND.	
	552	BOLTS/BOULONS 3/4" X 2"	150.2
	446	BOLTS/BOULONS 3/4" X 2 1/4"	129.0
	75	BOLTS/BOULONS 3/4" X 2 1/2"	22.8
	2	BOLTS/BOULONS 3/4" X 2 3/4"	0.6
	1075	LOCK W./R. DE BLOCAGE 3/4"	31.9
	38	R. FILLS/ESPACEURS 3/4" X 9.5	3.6
	2	R. FILLS/ESPACEURS 3/4" X 7.9	0.2
	141	BOLTS/BOULONS 1/2" X 1 1/2"	12.7
	32	BOLTS/BOULONS 1/2" X 1 3/4"	3.1
	5	BOLTS/BOULONS 1/2" X 2"	0.5
	3	BOLTS/BOULONS 1/2" X 2 3/4"	0.4
	181	LOCK W./R. DE BLOCAGE 1/2"	1.7
	4	R. FILLS/ESPACEURS 1/2" X 7.9	0.2
	20	CLIPS/ATTACHES TYPE "D-19"	0.5
	20	BOLTS/BOULONS 5/16" X 2 1/2"	0.5
TOTAL WEIGHT / MASSE TOTALE :			4430.9 kg

Pêches et Océans / Fisheries and Oceans
Canada / Canada

Garde côtière / Coast Guard

Services techniques / Systèmes électroniques et informatiques / Informations techniques et graphiques

101 Boul. Champblain (dépot 18) / Québec (Québec) G1K 7Y7

NOTES

- CAPACITÉ DE LA STRUCTURE AUX POINTS D'ANCRAGE = 18 kN
- ANNEAU DE SÉCURITÉ "D-RING": -CAPACITÉ MAXIMALE = 140 kg.
- HAUTEUR DE CHUTE LIBRE MAXIMALE = 1.8m.
- JAMAIS PLUS D'UN SYSTÈME DE PROTECTION PERSONNEL À LA FOIS AVEC TOUTE LA QUINCAILLERIE REQUISE POUR SON INSTALLATION.
- NUANCE D'ACIER: TOUS LES ÉLÉMENTS 300 Mpa SAUF LES ÉLÉMENTS SUIVANTS: LES CORNIÈRES: 350 Mpa LES PROFILÉS W: 350 Mpa
- TOUS LES BOULONS SELON ASTM A-325, TYPE 1.
- TOUTES LES RONDELLES DE BLOCAGE SELON ASME B18.21.1
- TOUS LES ESPACEURS ANNULAIRES SELON ANSI B18.22.1
- LONGUEUR DES BOULONS: 2" LG POUR BOULON 3/4", S.I.C. 1 1/2" LG POUR BOULON 1/2", S.I.C.
- TOUTES LES QUANTITÉS DE BOULON INCLUENT UN SURPLUS DE 5 %.
- CAPACITY OF THE STRUCTURE AT ANCHOR POINTS = 18 kN
- SECURITY RINGS "D-RING": -MAXIMUM CAPACITY = 140 kg.
- MAXIMUM FALLING HEIGHT = 1.8m.
- NEVER MORE THAN ONE PERSONAL SECURITY SYSTEM AT THE SAME TIME.
- THE LADDER SHOULD BE EQUIPPED WITH A SAFETY RAIL "DBI-SALA LAD-SAF" MODEL OR EQUIVALENT APPROVED BY CGC) WITH ALL HARDWARE REQUIRED FOR MOUNTING.
- STEEL GRADE: ALL MEMBERS 300 Mpa EXCEPT FOR: ANGLES: 350 Mpa W SHAPE: 350 Mpa
- ALL BOLTS ACCORDING TO ASTM A-325, TYPE 1.
- ALL LOCK WASHERS ACCORDING TO ASME B18.21.1
- ALL RING FILLS ACCORDING TO ANSI B18.22.1
- BOLT LENGTH: 2" LG FOR 3/4" BOLT, U.N. 1 1/2" LG FOR 1/2" BOLT, U.N.
- ALL BOLT QUANTITIES INCLUDE 5 % EXTRA.

Revision	Description	Par/By	Date
1	M122 ADDED/M122 AJOUTÉ	M.V.	2006.03.13

Tour de 13.5m (45pi) PLAN DE MONTAGE

Conçu par: P-C.GAGNON, ing. / 2003/05/30

Dessiné par: MICHEL VACHON / 2006/02/06

Vérifié par: MICHEL VACHON / 2006/02/06

Approuvé par:

No. dossier: 08990 / Echelle: 1 = 40

No. dessin: / No. feuille:

HEIGHT OF TOWER / HAUTEUR DE LA TOUR	10'	15'	20'	25'	30'	35'	40'	45'	50'	55'	60'	65'	70'	75'	80'
QUANTITY REQUIRED / QUANTITÉ REQUISE	8	8	8	8	8	16	16	16	24	24	24	24	32	32	32
ERECTION DRAWING / DESSIN DE MONTAGE	08990-SM-01	08990-SM-02	08990-SM-03	08990-SM-04	08990-SM-05	08990-SM-06	08990-SM-07	08990-SM-08	08990-SM-09	08990-SM-10	08990-SM-11	08990-SM-12	08990-SM-13	08990-SM-14	08990-SM-15

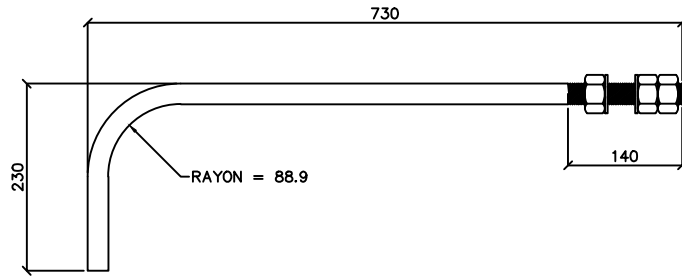

WEIGHT / MASSE: 4.4 Kg

QTY	MRK	DESCRIPTION	LENGTH	GRADE	REMARK	WEIGHT	QTY	MRK	DESCRIPTION	LENGTH	GRADE	REMARK	WEIGHT
QTÉ	MQE	DESCRIPTION	LONG.	NUANCE	REMARQUE	MASSE	QTÉ	MQE	DESCRIPTION	LONG.	NUANCE	REMARQUE	MASSE
-	M001	● 25.4 Ø X	890	A-325	BEND / PLIÉE	3.7							
					C/W / C/A								
					3 NUTS / ÉCROUS	0.6							
					2 WASH. / ROND.	0.1							

-	-	-
No	REVISION	DATE
	Pêches et Océans Canada	Fisheries and Oceans Canada
	Garde côtière	Coast Guard
	DESSIN MICHEL VACHON INC. DESSIN DE STRUCTURES MÉTALLIQUES TÉLÉPHONE: (418) 636-8386 TÉLÉCOPIER: (418) 636-7888	
STEEL TOWERS / TOURS D'ACIER		
MATERIAL: MATÉRIEL:	ASTM	HOLE: TROUS:
DRAWN: DESSINÉ:	M. VACHON	CHECKED: VÉRIFIÉ:
SCALE: ÉCHELLE:	1 = 5	FILE: DOSSIER:
		DATE: DATE:
		DRAWING: DESSIN:
		2005/11/29
		M001

HEIGHT OF TOWER / HAUTEUR DE LA TOUR	10'	15'	20'	25'	30'	35'	40'	45'	50'	55'	60'	65'	70'	75'	80'
QUANTITY REQUIRED / QUANTITÉ REQUISE	0	0	0	4	4	0	0	0	0	0	0	0	0	0	0
ERECTION DRAWING / DESSIN DE MONTAGE	08990-SM-01	08990-SM-02	08990-SM-03	08990-SM-04	08990-SM-05	08990-SM-06	08990-SM-07	08990-SM-08	08990-SM-09	08990-SM-10	08990-SM-11	08990-SM-12	08990-SM-13	08990-SM-14	08990-SM-15

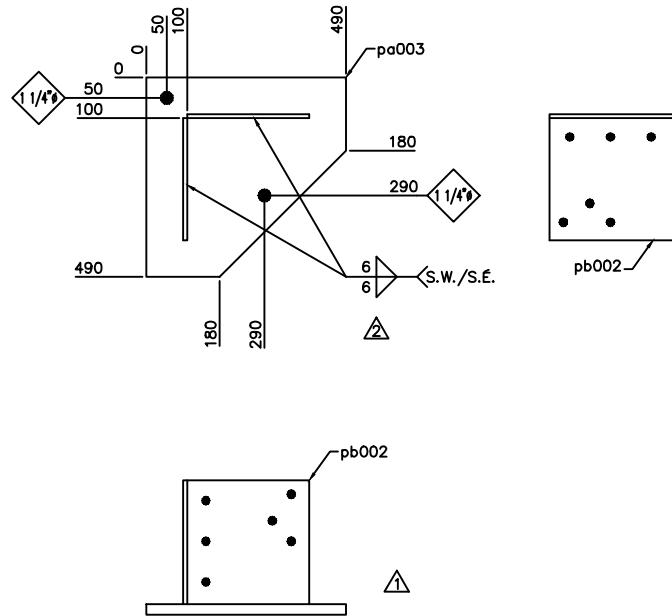

WEIGHT / MASSE: 53.8 Kg

QTY	MRK	DESCRIPTION	LENGTH	GRADE	REMARK	WEIGHT	QTY	MRK	DESCRIPTION	LENGTH	GRADE	REMARK	WEIGHT
QTÉ	MQE	DESCRIPTION	LONG.	NUANCE	REMARQUE	MASSE	QTÉ	MQE	DESCRIPTION	LONG.	NUANCE	REMARQUE	MASSE
1	pa003	PL 25.4 X 490	490	300W	ASS. #B003	39.6							
2	pb002	FB 9.53 X 305	300	300W		14.2							

2	SOUDEURE REVISÉE	2006/02/09			
1	SOUDEURE VERTICALE ENLEVÉE	2006/01/13			
No	REVISION	DATE			
Pêches et Océans Canada Fisheries and Oceans Canada Garde côtière Coast Guard					
DESSIN MICHEL VACHON INC. DESSIN DE STRUCTURES MÉTALLIQUES TÉLÉPHONE: (418) 636-8386 TÉLÉCOPIEUR: (418) 636-7988					
STEEL TOWERS / TOURS D'ACIER					
MATERIAL:	G40.21M	HOLE:	13/16" ø	U.S. FINISH:	GALV.
MATÉRIEL:		TROUS:		S.N. FINI:	
DRAWN:	M.VACHON	CHECKED:	M.VACHON	DATE:	2005/11/30
DESSINÉ:		VÉRIFIÉ:		DATE:	
SCALE:	1 = 10	FILE:	08990-SA	DRAWING:	B003/2
ÉCHELLE:		DOSSIER:		DESSIN:	

HEIGHT OF TOWER / HAUTEUR DE LA TOUR	10'	15'	20'	25'	30'	35'	40'	45'	50'	55'	60'	65'	70'	75'	80'
QUANTITY REQUIRED / QUANTITÉ REQUISE	0	0	0	0	0	0	0	0	4	4	4	0	0	0	0
ERECTION DRAWING / DESSIN DE MONTAGE	08990-SM-01	08990-SM-02	08990-SM-03	08990-SM-04	08990-SM-05	08990-SM-06	08990-SM-07	08990-SM-08	08990-SM-09	08990-SM-10	08990-SM-11	08990-SM-12	08990-SM-13	08990-SM-14	08990-SM-15

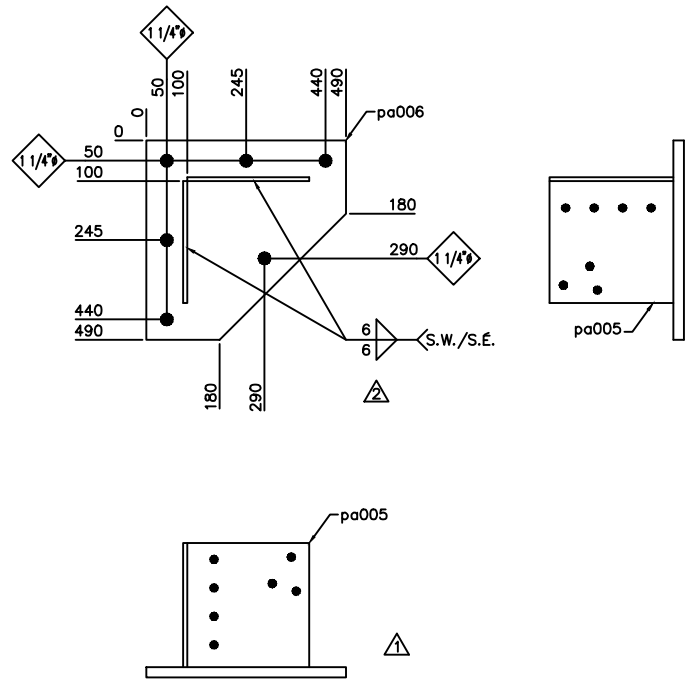

WEIGHT / MASSE: 53.8 Kg

QTY QTÉ	MRK MQE	DESCRIPTION	LENGTH LONG.	GRADE NUANCE	REMARK REMARQUE	WEIGHT MASSE	QTY QTÉ	MRK MQE	DESCRIPTION	LENGTH LONG.	GRADE NUANCE	REMARK REMARQUE	WEIGHT MASSE
1	pa006	PL 25.4 X 490	490	300W	ASS. #B006	39.6							
2	pa005	FB 9.53 X 305	300	300W		14.2							

2	SOUDEURE REVISÉE	2006/02/09		
1	SOUDEURE VERTICALE ENLEVÉE	2006/01/13		
No	REVISION	DATE		
Pêches et Océans / Fisheries and Oceans Canada / Canada Garde côtière / Coast Guard				
DESSIN MICHEL VACHON INC. DESSIN DE STRUCTURES MÉTALLIQUES TÉLÉPHONE: (418) 638-6386 TÉLÉCOPIEUR: (418) 638-7888				
STEEL TOWERS / TOURS D'ACIER				
MATERIAL: MATÉRIEL:	G40.21M	FINISH: FINI:	GALV.	
HOLES: TROUS:	13/16" ø	U.A. S.N.		
DRAWN: DESSINÉ:	M. VACHON	CHECKED: VÉRIFIÉ:	M. VACHON	
SCALE: ÉCHELLE:	1 = 10	DATE: DATE:	2005/11/30	
	FILE: DOSSIER:	08990-SA	DRAWING: DESSIN:	B006/2

HEIGHT OF TOWER / HAUTEUR DE LA TOUR	10'	15'	20'	25'	30'	35'	40'	45'	50'	55'	60'	65'	70'	75'	80'
QUANTITY REQUIRED / QUANTITÉ REQUISE	4	4	4	4	4	4	4	4	4	4	4	4	4	4	4
ERECTION DRAWING / DESSIN DE MONTAGE	08990-SM-01	08990-SM-02	08990-SM-03	08990-SM-04	08990-SM-05	08990-SM-06	08990-SM-07	08990-SM-08	08990-SM-09	08990-SM-10	08990-SM-11	08990-SM-12	08990-SM-13	08990-SM-14	08990-SM-15

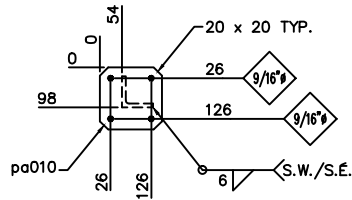
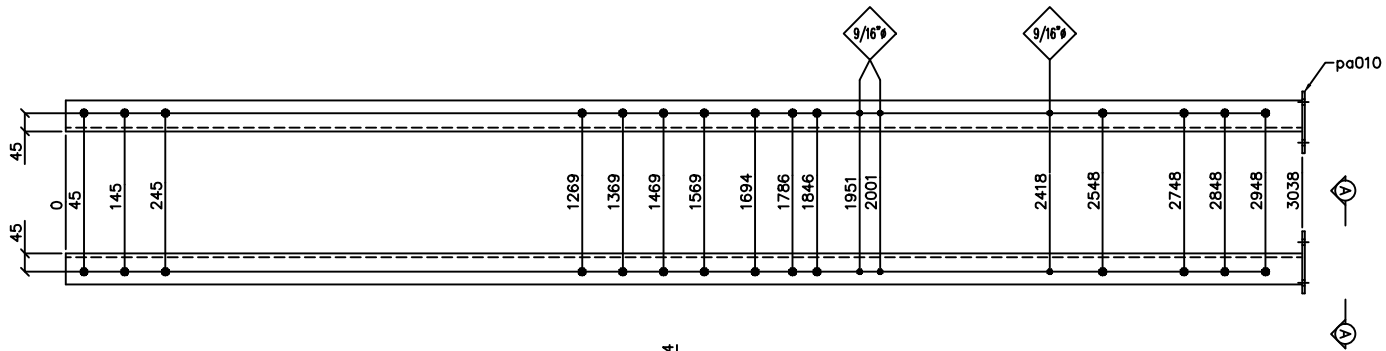

VIEW A-A / VUE A-A

WEIGHT / MASSE: 34.8 Kg

QTY	MRK	DESCRIPTION	LENGTH	GRADE	REMARK	WEIGHT	QTY	MRK	DESCRIPTION	LENGTH	GRADE	REMARK	WEIGHT
QTÉ	MQE	DESCRIPTION	LONG.	NUANCE	REMARQUE	MASSE	QTÉ	MQE	DESCRIPTION	LONG.	NUANCE	REMARQUE	MASSE
1	O10	L 76 76	9.53	3038	350W	33.6							
1	pa010	FB 6.35 X 152	152	300W	ASS. #V010	1.2							

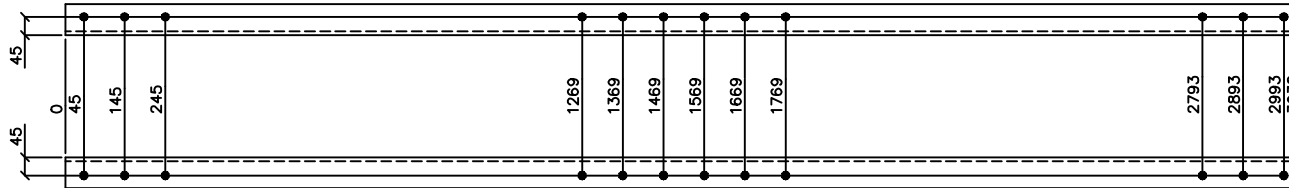

No	REVISION	DATE			
Pêches et Océans Canada		Fisheries and Oceans Canada			
Garde côtière		Coast Guard			
DESSIN MICHEL VACHON INC. DESSIN DE STRUCTURES MÉTALLIQUES TÉLÉPHONE: (418) 638-4386 TÉLÉCOPIEUR: (418) 638-7888					
STEEL TOWERS / TOURS D'ACIER					
MATERIAL:	G40.21M	HOLES:	13/16" Ø	U.N. FINISH:	GALV.
DRAWN:	M. VACHON	CHECKED:	M. VACHON	DATE:	2005/12/01
SCALE:	1 = 10	FILES:	08990-SA	DRAWING:	V010
ÉCHELLE:		DOSSIER:		DESSIN:	

HEIGHT OF TOWER / HAUTEUR DE LA TOUR	10'	15'	20'	25'	30'	35'	40'	45'	50'	55'	60'	65'	70'	75'	80'
QUANTITY REQUIRED / QUANTITÉ REQUISE	0	0	4	4	8	4	4	4	4	4	4	8	8	8	8
ERECTION DRAWING / DESSIN DE MONTAGE	08990-SM-01	08990-SM-02	08990-SM-03	08990-SM-04	08990-SM-05	08990-SM-06	08990-SM-07	08990-SM-08	08990-SM-09	08990-SM-10	08990-SM-11	08990-SM-12	08990-SM-13	08990-SM-14	08990-SM-15



WEIGHT / MASSE: 33.6 Kg

QTY	MRK	DESCRIPTION	LENGTH	GRADE	REMARK	WEIGHT	QTY	MRK	DESCRIPTION	LENGTH	GRADE	REMARK	WEIGHT
QTÉ	MQE	DESCRIPTION	LONG.	NUANCE	REMARQUE	MASSE	QTÉ	MQE	DESCRIPTION	LONG.	NUANCE	REMARQUE	MASSE
1	V012	L 76 76	9.53	3038	350W	33.6							

-	-	-
No	REVISION	DATE
	Pêches et Océans Canada	Fisheries and Oceans Canada
	Garde côtière	Coast Guard
	DESSIN MICHEL VACHON INC. DESSIN DE STRUCTURES MÉTALLIQUES TÉLÉPHONE: (418) 636-8386 TÉLÉCOPIER: (418) 636-7888	
STEEL TOWERS / TOURS D'ACIER		
MATERIAL: MATÉRIEL:	G40.21M	HOLE: TROUS:
13/16" ø	U.S. FINISH: P.NE:	GALV.
DRAWN: DESSINÉ:	M. VACHON	CHECKED: VÉRIFIÉ:
M. VACHON	M. VACHON	DATE: DATE:
2005/12/05		
SCALE: ÉCHELLE:	1 = 10	FILE: DOSSIER:
08990-SA	DRAWING: DESSIN:	V012 / 0

HEIGHT OF TOWER / HAUTEUR DE LA TOUR	10'	15'	20'	25'	30'	35'	40'	45'	50'	55'	60'	65'	70'	75'	80'
QUANTITY REQUIRED / QUANTITÉ REQUISE	8	18	26	36	44	54	62	72	80	90	98	0	0	0	0
ERECTION DRAWING / DESSIN DE MONTAGE	08990-SM-01	08990-SM-02	08990-SM-03	08990-SM-04	08990-SM-05	08990-SM-06	08990-SM-07	08990-SM-08	08990-SM-09	08990-SM-10	08990-SM-11	08990-SM-12	08990-SM-13	08990-SM-14	08990-SM-15

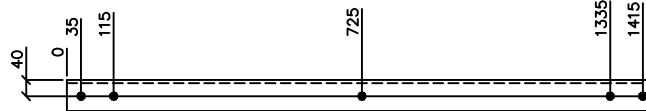

WEIGHT / MASSE: 12.7 Kg

QTY	MRK	DESCRIPTION			LENGTH	GRADE	REMARK	WEIGHT	QTY	MRK	DESCRIPTION			LENGTH	GRADE	REMARK	WEIGHT
QTÉ	MQE	DESCRIPTION			LONG.	NUANCE	REMARQUE	MASSE	QTÉ	MQE	DESCRIPTION			LONG.	NUANCE	REMARQUE	MASSE
1	X022	L	76	76	7.94	1450	350W	12.7									

1	GRADE CHANGED/NUANCE CHANGÉE	2006/03/22				
No	REVISION	DATE				
	Pêches et Océans Canada	Fisheries and Oceans Canada				
	Garde côtière	Coast Guard				
	DESSIN MICHEL VACHON INC. DESSIN DE STRUCTURES MÉTALLIQUES TÉLÉPHONE: (418) 636-8386 TÉLÉCOPIER: (418) 636-7888					
STEEL TOWERS / TOURS D'ACIER						
MATERIAL: MATÉRIEL:	G40.21M	HOLE: TROUS:	13/16" ø	U.S. S.N.	FINISH: FINI:	GALV.
DRAWN: DESSINÉ:	M. VACHON	CHECKED: VÉRIFIÉ:	M. VACHON	DATE:	2005/12/05	
SCALE: ÉCHELLE:	1 = 10	FILE: DOSSIER:	08990-SA	DRAWING: DESSIN:	X022	

HEIGHT OF TOWER / HAUTEUR DE LA TOUR	10'	15'	20'	25'	30'	35'	40'	45'	50'	55'	60'	65'	70'	75'	80'
QUANTITY REQUIRED / QUANTITÉ REQUISE	3	3	3	3	3	3	3	3	3	3	3	0	0	0	0
ERECTION DRAWING / DESSIN DE MONTAGE	08990-SM-01	08990-SM-02	08990-SM-03	08990-SM-04	08990-SM-05	08990-SM-06	08990-SM-07	08990-SM-08	08990-SM-09	08990-SM-10	08990-SM-11	08990-SM-12	08990-SM-13	08990-SM-14	08990-SM-15

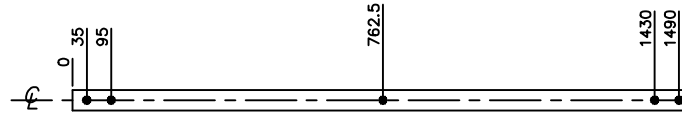

WEIGHT / MASSE: 4.0 Kg

QTY QTÉ	MRK MQE	DESCRIPTION	LENGTH LONG.	GRADE NUANCE	REMARK REMARQUE	WEIGHT MASSE	QTY QTÉ	MRK MQE	DESCRIPTION	LENGTH LONG.	GRADE NUANCE	REMARK REMARQUE	WEIGHT MASSE
1	X023	FL 6.35 X 51	1525	300W		4.0							

-	-	-
No	REVISION	DATE
	Pêches et Océans Canada	Fisheries and Oceans Canada
	Garde côtière	Coast Guard
	DESSIN MICHEL VACHON INC. DESSIN DE STRUCTURES MÉTALLIQUES TÉLÉPHONE: (418) 636-8386 TÉLÉCOPIER: (418) 636-7888	
STEEL TOWERS / TOURS D'ACIER		
MATERIAL: MATERIEL:	G40.21M	HOLE: TROUS:
DRW: DESSINÉ:	M. VACHON	CHEKED: VÉRIFIÉ:
SCALE: ÉCHELLE:	1 = 10	FILE: DOSSIER:
		DATE: DATE:
		FINISH: FINI:
		DATE: DATE:
		DRAWING: DESSIN:
		X023 / 0

HEIGHT OF TOWER / HAUTEUR DE LA TOUR	10'	15'	20'	25'	30'	35'	40'	45'	50'	55'	60'	65'	70'	75'	80'
QUANTITY REQUIRED / QUANTITÉ REQUISE	3	3	3	3	3	3	3	3	3	3	3	0	0	0	0
ERECTION DRAWING / DESSIN DE MONTAGE	08990-SM-01	08990-SM-02	08990-SM-03	08990-SM-04	08990-SM-05	08990-SM-06	08990-SM-07	08990-SM-08	08990-SM-09	08990-SM-10	08990-SM-11	08990-SM-12	08990-SM-13	08990-SM-14	08990-SM-15

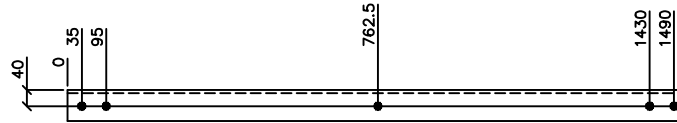

WEIGHT / MASSE: 13.4 Kg

QTY	MRK	DESCRIPTION			LENGTH	GRADE	REMARK	WEIGHT	QTY	MRK	DESCRIPTION			LENGTH	GRADE	REMARK	WEIGHT
QTÉ	MQE				LONG.	NUANCE	REMARQUE	MASSE	QTÉ	MQE			LONG.	NUANCE	REMARQUE	MASSE	
1	X027	L	76	76	7.94	1525	350W	13.4									

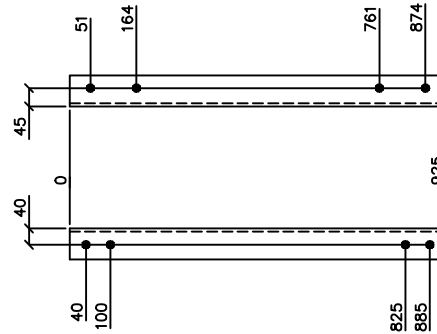

1	GRADE CHANGED/NUANCE CHANGÉE	2006/03/22					
No	REVISION	DATE					
	Pêches et Océans Canada	Fisheries and Oceans Canada					
	Garde côtière	Coast Guard					
	DESSIN MICHEL VACHON INC. DESSIN DE STRUCTURES MÉTALLIQUES TÉLÉPHONE: (418) 636-4386 TÉLÉCOPIER: (418) 636-7888						
STEEL TOWERS / TOURS D'ACIER							
MATERIAL:	G40.21M	HOLE:	13/16" ø	U.I.:	S.N.	FINISH:	GALV.
MATÉRIEL:		TROUS:		U.I.:	S.N.	FINISH:	
DRAWN:	M.VACHON	CHECKED:	M.VACHON	DATE:	2005/12/05		
DESSINÉ:		VÉRIFIÉ:		DATE:			
SCALE:	1 = 10	FILE:	08990-SA	DRAWING:	X027		
ÉCHELLE:		DOSSIER:		DESSIN:			

HEIGHT OF TOWER / HAUTEUR DE LA TOUR	10'	15'	20'	25'	30'	35'	40'	45'	50'	55'	60'	65'	70'	75'	80'
QUANTITY REQUIRED / QUANTITÉ REQUISE	3	6	9	12	15	18	21	24	27	30	33	0	0	0	0
ERECTION DRAWING / DESSIN DE MONTAGE	08990-SM-01	08990-SM-02	08990-SM-03	08990-SM-04	08990-SM-05	08990-SM-06	08990-SM-07	08990-SM-08	08990-SM-09	08990-SM-10	08990-SM-11	08990-SM-12	08990-SM-13	08990-SM-14	08990-SM-15



WEIGHT / MASSE: 8.1 Kg

QTY	MRK	DESCRIPTION			LENGTH	GRADE	REMARK	WEIGHT	QTY	MRK	DESCRIPTION			LENGTH	GRADE	REMARK	WEIGHT
QTÉ	MQE				LONG.	NUANCE	REMARQUE	MASSE	QTÉ	MQE			LONG.	NUANCE	REMARQUE	MASSE	
1	H029	L	76	76	7.94	925	350W	8.1									

1	GRADE CHANGED/NUANCE CHANGÉE	2006/03/22					
No	REVISION	DATE					
	Pêches et Océans Canada	Fisheries and Oceans Canada					
	Garde côtière	Coast Guard					
	DESSIN MICHEL VACHON INC. DESSIN DE STRUCTURES MÉTALLIQUES TÉLÉPHONE: (418) 638-4386 TÉLÉCOPIEUR: (418) 638-7888						
STEEL TOWERS / TOURS D'ACIER							
MATERIAL:	G40.21M	HOLES:	13/16" ø	U.N.:	S.N.	FINISH:	GALV.
DRAWN:	M.VACHON	CHECKED:	M.VACHON	DATE:	2005/12/06		
SCALE:	1 = 10	FILES:	08990-SA	DRAWING:	H029		
ÉCHELLE:		DOSSIER:		DESSIN:			

HEIGHT OF TOWER / HAUTEUR DE LA TOUR	10'	15'	20'	25'	30'	35'	40'	45'	50'	55'	60'	65'	70'	75'	80'
QUANTITY REQUIRED / QUANTITÉ REQUISE	1	2	3	4	5	6	7	8	9	10	11	0	0	0	0
ERECTION DRAWING / DESSIN DE MONTAGE	08990-SM-01	08990-SM-02	08990-SM-03	08990-SM-04	08990-SM-05	08990-SM-06	08990-SM-07	08990-SM-08	08990-SM-09	08990-SM-10	08990-SM-11	08990-SM-12	08990-SM-13	08990-SM-14	08990-SM-15

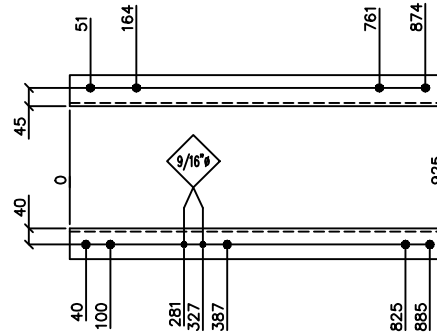

WEIGHT / MASSE: 8.1 Kg

QTY	MRK	DESCRIPTION	LENGTH	GRADE	REMARK	WEIGHT	QTY	MRK	DESCRIPTION	LENGTH	GRADE	REMARK	WEIGHT
QTÉ	MQE	DESCRIPTION	LONG.	NUANCE	REMARQUE	MASSE	QTÉ	MQE	DESCRIPTION	LONG.	NUANCE	REMARQUE	MASSE
1	H030	L 76 76	7.94	925	350W	8.1							

1	GRADE CHANGED / NUANCE CHANGÉE	2006/03/22
No	REVISION	DATE
	Pêches et Océans Canada	Fisheries and Oceans Canada
	Garde côtière	Coast Guard
	DESSIN MICHEL VACHON INC. DESSIN DE STRUCTURES METALLIQUES TÉLÉPHONE: (418) 636-4386 TÉLÉCOPIER: (418) 636-7888	
STEEL TOWERS / TOURS D'ACIER		
MATERIAL:	G40.21M	H030
MATÉRIEL:		
DRW:	M.VACHON	CHK:
DESSINÉ:		VÉRIFIÉ:
SCALE:	1 = 10	FILE:
ÉCHELLE:		DOSSIER:
		DATE:
		DESSIN:

HEIGHT OF TOWER / HAUTEUR DE LA TOUR	10'	15'	20'	25'	30'	35'	40'	45'	50'	55'	60'	65'	70'	75'	80'
QUANTITY REQUIRED / QUANTITÉ REQUISE	1	1	1	1	1	1	1	1	1	1	1	0	0	0	0
ERECTION DRAWING / DESSIN DE MONTAGE	08990-SM-01	08990-SM-02	08990-SM-03	08990-SM-04	08990-SM-05	08990-SM-06	08990-SM-07	08990-SM-08	08990-SM-09	08990-SM-10	08990-SM-11	08990-SM-12	08990-SM-13	08990-SM-14	08990-SM-15

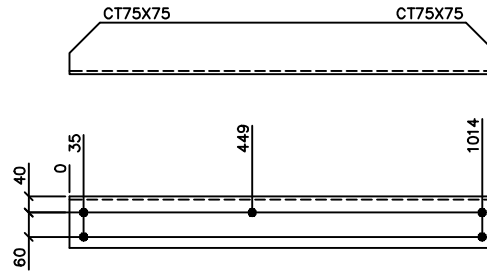

WEIGHT / MASSE: 16.6 Kg

QTY	MRK	DESCRIPTION	LENGTH	GRADE	REMARK	WEIGHT	QTY	MRK	DESCRIPTION	LENGTH	GRADE	REMARK	WEIGHT
QTÉ	MQE	DESCRIPTION	LONG.	NUANCE	REMARQUE	MASSE	QTÉ	MQE	DESCRIPTION	LONG.	NUANCE	REMARQUE	MASSE
1	H031	L 127 127	7.94	1049	350W	16.6							

1	GRADE CHANGED/NUANCE CHANGÉE	2006/03/22					
No	REVISION	DATE					
	Pêches et Océans Canada	Fisheries and Oceans Canada					
	Garde côtière	Coast Guard					
	DESSIN MICHEL VACHON INC. DESSIN DE STRUCTURES MÉTALLIQUES TÉLÉPHONE: (418) 636-8386 TÉLÉCOPIER: (418) 636-7888						
STEEL TOWERS / TOURS D'ACIER							
MATERIAL:	G40.21M	HOLE:	13/16" ø	U.N.:	S.N.	FINISH:	GALV.
MATÉRIEL:		TROUS:		U.N.:	S.N.	FINI:	
DRAWN:	M.VACHON	CHECKED:	M.VACHON	DATE:	2005/12/06		
DESSINÉ:		VÉRIFIÉ:		DATE:			
SCALE:	1 = 10	FILE:	08990-SA	DRAWING:	H031		
ÉCHELLE:		DOSSIER:		DESSIN:			

HEIGHT OF TOWER / HAUTEUR DE LA TOUR	10'	15'	20'	25'	30'	35'	40'	45'	50'	55'	60'	65'	70'	75'	80'
QUANTITY REQUIRED / QUANTITÉ REQUISE	3	3	3	3	3	3	3	3	3	3	0	0	0	0	0
ERECTION DRAWING / DESSIN DE MONTAGE	08990-SM-01	08990-SM-02	08990-SM-03	08990-SM-04	08990-SM-05	08990-SM-06	08990-SM-07	08990-SM-08	08990-SM-09	08990-SM-10	08990-SM-11	08990-SM-12	08990-SM-13	08990-SM-14	08990-SM-15

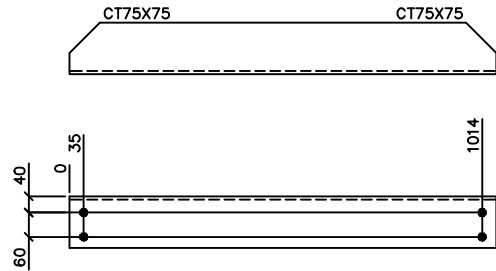

WEIGHT / MASSE: 16.6 Kg

QTY	MRK	DESCRIPTION	LENGTH	GRADE	REMARK	WEIGHT	QTY	MRK	DESCRIPTION	LENGTH	GRADE	REMARK	WEIGHT
QTÉ	MQE	DESCRIPTION	LONG.	NUANCE	REMARQUE	MASSE	QTÉ	MQE	DESCRIPTION	LONG.	NUANCE	REMARQUE	MASSE
1	H032	L 127 127	7.94	1049	350W	16.6							

1	GRADE CHANGED/NUANCE CHANGÉE	2006/03/22					
No	REVISION	DATE					
	Pêches et Océans Canada	Fisheries and Oceans Canada					
	Garde côtière	Coast Guard					
	DESSIN MICHEL VACHON INC. DESSIN DE STRUCTURES MÉTALLIQUES TÉLÉPHONE: (418) 636-8386 TÉLÉCOPIER: (418) 636-7888						
STEEL TOWERS / TOURS D'ACIER							
MATERIAL:	G40.21M	HOLE:	13/16" ø	U.N.:	S.N.	FINISH:	GALV.
DRAWN:	M.VACHON	CHECKED:	M.VACHON	DATE:	2005/12/06		
SCALE:	1 = 10	FILE:	08990-SA	DRAWING:	H032		
ÉCHELLE:		DOSSIER:		DESSIN:			

HEIGHT OF TOWER / HAUTEUR DE LA TOUR	10'	15'	20'	25'	30'	35'	40'	45'	50'	55'	60'	65'	70'	75'	80'
QUANTITY REQUIRED / QUANTITÉ REQUISE	1	1	1	1	1	1	1	1	1	1	1	0	0	0	0
ERECTION DRAWING / DESSIN DE MONTAGE	08990-SM-01	08990-SM-02	08990-SM-03	08990-SM-04	08990-SM-05	08990-SM-06	08990-SM-07	08990-SM-08	08990-SM-09	08990-SM-10	08990-SM-11	08990-SM-12	08990-SM-13	08990-SM-14	08990-SM-15

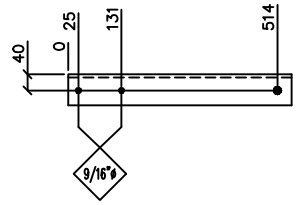

WEIGHT / MASSE: 5.2 Kg

QTY	MRK	DESCRIPTION	LENGTH	GRADE	REMARK	WEIGHT	QTY	MRK	DESCRIPTION	LENGTH	GRADE	REMARK	WEIGHT
QTÉ	MQE	DESCRIPTION	LONG.	NUANCE	REMARQUE	MASSE	QTÉ	MQE	DESCRIPTION	LONG.	NUANCE	REMARQUE	MASSE
1	P033	L 76 76 7.94	549	350W		5.2							

2	GRADE CHANGED/NUANCE CHANGÉE	2006/03/22					
1	NOUVELLE DÉSIGNATION	2006/01/19					
No	REVISION	DATE					
	Pêches et Océans Canada	Fisheries and Oceans Canada					
	Garde côtière	Coast Guard					
	DESSIN MICHEL VACHON INC. DESSIN DE STRUCTURES MÉTALLIQUES TÉLÉPHONE: (418) 636-8386 TÉLÉCOPIER: (418) 636-7988						
STEEL TOWERS / TOURS D'ACIER							
MATERIAL:	G40.21M	HOLE:	13/16" ø	U.N.:	S.N.	FINISH:	GALV.
MATÉRIEL:		TROUS:		U.N.:	S.N.	FINISH:	
DRAWN:	M.VACHON	CHECKED:	M.VACHON	DATE:	2005/12/06		
DESSINÉ:		VÉRIFIÉ:		DATE:			
SCALE:	1 = 10	FILE:	08990-SA	DRAWING:	P033		
ÉCHELLE:		DOSSIER:		DESSIN:			

HEIGHT OF TOWER / HAUTEUR DE LA TOUR	10'	15'	20'	25'	30'	35'	40'	45'	50'	55'	60'	65'	70'	75'	80'
QUANTITY REQUIRED / QUANTITÉ REQUISE	1	1	1	1	1	1	1	1	1	1	1	0	0	0	0
ERECTION DRAWING / DESSIN DE MONTAGE	08990-SM-01	08990-SM-02	08990-SM-03	08990-SM-04	08990-SM-05	08990-SM-06	08990-SM-07	08990-SM-08	08990-SM-09	08990-SM-10	08990-SM-11	08990-SM-12	08990-SM-13	08990-SM-14	08990-SM-15

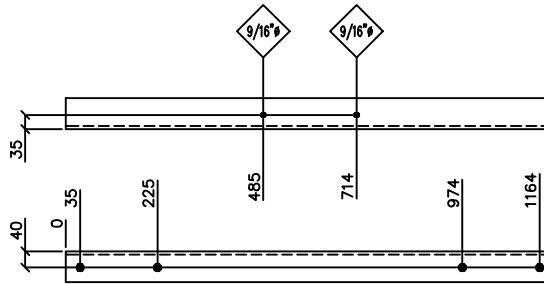

2	GRADE CHANGED/NUANCE CHANGÉE	2006/03/22
1	NOUVELLE DÉSIGNATION	2006/01/19

No	REVISION	DATE
	 Pêches et Océans Canada	Fisheries and Oceans Canada
	Garde côtière	Coast Guard

WEIGHT / MASSE: 11.3 Kg

QTY QTÉ	MRK MQE	DESCRIPTION	LENGTH LONG.	GRADE NUANCE	REMARK REMARQUE	WEIGHT MASSE	QTY QTÉ	MRK MQE	DESCRIPTION	LENGTH LONG.	GRADE NUANCE	REMARK REMARQUE	WEIGHT MASSE
1	P034	L 76 76	7.94	1199	350W	11.3							

 **DESSIN MICHEL VACHON INC.**
DESSIN DE STRUCTURES MÉTALLIQUES
TÉLÉPHONE: (418) 636-4386
TÉLÉCOPIER: (418) 636-7888

STEEL TOWERS / TOURS D'ACIER

MATERIAL: MATÉRIEL:	G40.21M	HOLES: TROUS:	13/16" ø	U.S. S.N.	FINISH: FINI:	GALV.
DRAWN: DESSINÉ:	M.VACHON	CHECKED: VÉRIFIÉ:	M.VACHON	DATE: DATE:	2005/12/06	
SCALE: ÉCHELLE:	1 = 10	FILE: DOSSIER:	08990-SA	DRAWING: DESSIN:	P034 / 2	

HEIGHT OF TOWER / HAUTEUR DE LA TOUR	10'	15'	20'	25'	30'	35'	40'	45'	50'	55'	60'	65'	70'	75'	80'
QUANTITY REQUIRED / QUANTITÉ REQUISE	1	1	1	1	1	1	1	1	1	1	1	0	0	0	0
ERECTION DRAWING / DESSIN DE MONTAGE	08990-SM-01	08990-SM-02	08990-SM-03	08990-SM-04	08990-SM-05	08990-SM-06	08990-SM-07	08990-SM-08	08990-SM-09	08990-SM-10	08990-SM-11	08990-SM-12	08990-SM-13	08990-SM-14	08990-SM-15

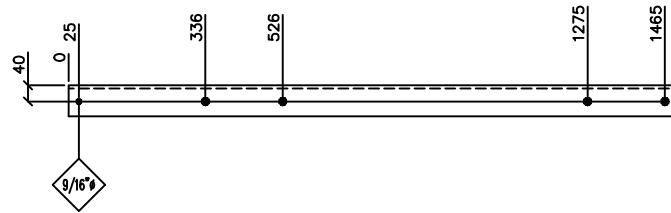

WEIGHT / MASSE: 14.1 Kg

QTY QTÉ	MRK MQE	DESCRIPTION	LENGTH LONG.	GRADE NUANCE	REMARK REMARQUE	WEIGHT MASSE	QTY QTÉ	MRK MQE	DESCRIPTION	LENGTH LONG.	GRADE NUANCE	REMARK REMARQUE	WEIGHT MASSE
1	P035	L 76 76 7.94	1500	350W		14.1							

2	GRADE CHANGED/NUANCE CHANGÉE	2006/03/22				
1	NOUVELLE DÉSIGNATION	2006/01/19				
No	REVISION	DATE				
	Pêches et Océans Canada	Fisheries and Oceans Canada				
	Garde côtière	Coast Guard				
	DESSIN MICHEL VACHON INC. DESSIN DE STRUCTURES MÉTALLIQUES TÉLÉPHONE: (418) 636-8386 TÉLÉCOPIER: (418) 636-7988					
STEEL TOWERS / TOURS D'ACIER						
MATERIAL: MATÉRIEL:	G40.21M	HOLES: TROUS:	13/16" ø	U.S. S.N.	FINISH: FINI:	GALV.
DRAWN: DESSINÉ:	M. VACHON	CHECKED: VÉRIFIÉ:	M. VACHON	DATE:	2005/12/06	
SCALE: ÉCHELLE:	1 = 10	FILE: DOSSIER:	08990-SA	DRAWING: DESSIN:	P035 / 2	

HEIGHT OF TOWER / HAUTEUR DE LA TOUR	10'	15'	20'	25'	30'	35'	40'	45'	50'	55'	60'	65'	70'	75'	80'
QUANTITY REQUIRED / QUANTITÉ REQUISE	1	1	1	1	1	1	1	1	1	1	1	0	0	0	0
ERECTION DRAWING / DESSIN DE MONTAGE	08990-SM-01	08990-SM-02	08990-SM-03	08990-SM-04	08990-SM-05	08990-SM-06	08990-SM-07	08990-SM-08	08990-SM-09	08990-SM-10	08990-SM-11	08990-SM-12	08990-SM-13	08990-SM-14	08990-SM-15

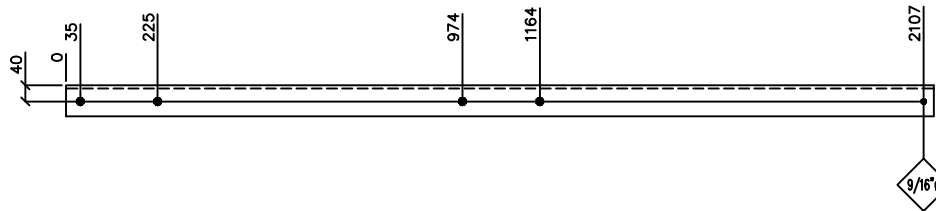

2	GRADE CHANGED/NUANCE CHANGÉE	2006/03/22
1	NOUVELLE DÉSIGNATION	2006/01/19

No	REVISION	DATE
	Pêches et Océans Canada	Fisheries and Oceans Canada
	Garde côtière	Coast Guard

DESSIN MICHEL VACHON INC.
DESSIN DE STRUCTURES MÉTALLIQUES
TÉLÉPHONE: (418) 636-8386
TÉLÉCOPIER: (418) 636-7988

WEIGHT / MASSE: 20.1 Kg

QTY	MRK	DESCRIPTION	LENGTH	GRADE	REMARK	WEIGHT	QTY	MRK	DESCRIPTION	LENGTH	GRADE	REMARK	WEIGHT
QTÉ	MQE	DESCRIPTION	LONG.	NUANCE	REMARQUE	MASSE	QTÉ	MQE	DESCRIPTION	LONG.	NUANCE	REMARQUE	MASSE
1	P036	L 76 76 7.94	2132	350W		20.1							

STEEL TOWERS / TOURS D'ACIER			
MATERIAL:	G40.21M	HOLES:	13/16" ø
MATÉRIEL:		TROUS:	U.S. FINISH:
DRAWN:	M.VACHON	CHECKED:	M.VACHON
DESSINÉ:		VÉRIFIÉ:	
SCALE:	1 = 10	FILE:	08990-SA
ÉCHELLE:		DOSSIER:	
		DATE:	2005/12/06
		DESSIN:	P036/2

HEIGHT OF TOWER / HAUTEUR DE LA TOUR	10'	15'	20'	25'	30'	35'	40'	45'	50'	55'	60'	65'	70'	75'	80'
QUANTITY REQUIRED / QUANTITÉ REQUISE	1	1	1	1	1	1	1	1	1	1	1	1	1	1	1
ERECTION DRAWING / DESSIN DE MONTAGE	08990-SM-01	08990-SM-02	08990-SM-03	08990-SM-04	08990-SM-05	08990-SM-06	08990-SM-07	08990-SM-08	08990-SM-09	08990-SM-10	08990-SM-11	08990-SM-12	08990-SM-13	08990-SM-14	08990-SM-15

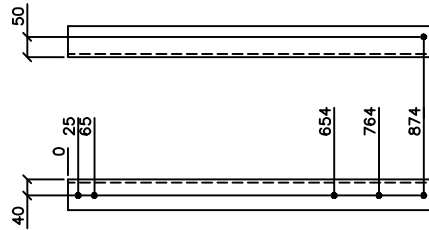

WEIGHT / MASSE: 8.6 Kg

QTY	MRK	DESCRIPTION			LENGTH	GRADE	REMARK	WEIGHT	QTY	MRK	DESCRIPTION			LENGTH	GRADE	REMARK	WEIGHT
QTE	MQE				LONG.	NUANCE	REMARQUE	MASSE	QTE	MQE			LONG.	NUANCE	REMARQUE	MASSE	
1	P045	L	76	76	7.94	909	350W	8.6									

1	GRADE CHANGED/NUANCE CHANGÉE	2006/03/22					
No	REVISION	DATE					
	Pêches et Océans Canada	Fisheries and Oceans Canada					
	Garde côtière	Coast Guard					
	DESSIN MICHEL VACHON INC. DESSIN DE STRUCTURES MÉTALLIQUES TÉLÉPHONE: (418) 636-4386 TÉLÉCOPIER: (418) 636-7888						
STEEL TOWERS / TOURS D'ACIER							
MATERIAL:	G40.21M	HOLE:	9/16" ø	U.I.:	S.N.	FINISH:	GALV.
DRAWN:	M.VACHON	CHECKED:	M.VACHON	DATE:	2005/12/08		
SCALE:	1 = 10	FILE:	08990-SA	DRAWING:	P045		
ÉCHELLE:		DOSSIER:		DESSIN:			

HEIGHT OF TOWER / HAUTEUR DE LA TOUR	10'	15'	20'	25'	30'	35'	40'	45'	50'	55'	60'	65'	70'	75'	80'
QUANTITY REQUIRED / QUANTITÉ REQUISE	1	1	1	1	1	1	1	1	1	1	1	1	1	1	1
ERECTION DRAWING / DESSIN DE MONTAGE	08990-SM-01	08990-SM-02	08990-SM-03	08990-SM-04	08990-SM-05	08990-SM-06	08990-SM-07	08990-SM-08	08990-SM-09	08990-SM-10	08990-SM-11	08990-SM-12	08990-SM-13	08990-SM-14	08990-SM-15

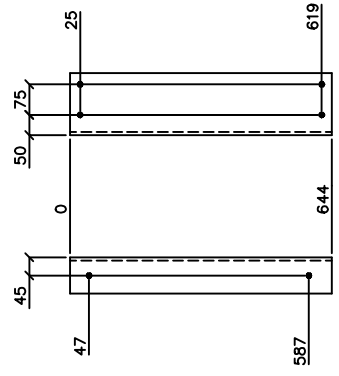

WEIGHT / MASSE: 9.7 Kg

QTY	MRK	DESCRIPTION	LENGTH	GRADE	REMARK	WEIGHT	QTY	MRK	DESCRIPTION	LENGTH	GRADE	REMARK	WEIGHT
QTÉ	MQE	DESCRIPTION	LONG.	NUANCE	REMARQUE	MASSE	QTÉ	MQE	DESCRIPTION	LONG.	NUANCE	REMARQUE	MASSE
1	P046	L 152 89 7.94	644	350W		9.7							

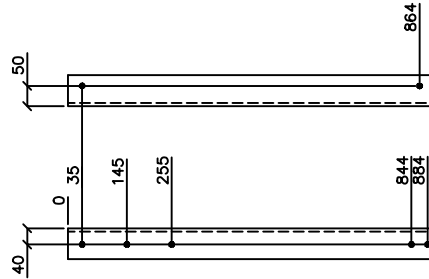

1	GRADE CHANGED / NUANCE CHANGÉE	2006/03/22				
No	REVISION	DATE				
	Pêches et Océans Canada	Fisheries and Oceans Canada				
	Garde côtière	Coast Guard				
	DESSIN MICHEL VACHON INC. DESSIN DE STRUCTURES MÉTALLIQUES TÉLÉPHONE: (418) 636-4386 TÉLÉCOPIEUR: (418) 636-7988					
STEEL TOWERS / TOURS D'ACIER						
MATERIAL:	G40.21M	HOLE:	9/16" ø	U.S. S.N.:	FINISH:	GALV.
DRAWN:	M. VACHON	CHECKED:	M. VACHON	DATE:	2005/12/08	
SCALE:	1 = 10	FILE:	08990-SA	DRAWING:	P046	
ÉCHELLE:		DOSSIER:		DESSIN:		

HEIGHT OF TOWER / HAUTEUR DE LA TOUR	10'	15'	20'	25'	30'	35'	40'	45'	50'	55'	60'	65'	70'	75'	80'
QUANTITY REQUIRED / QUANTITÉ REQUISE	1	1	1	1	1	1	1	1	1	1	1	1	1	1	1
ERECTION DRAWING / DESSIN DE MONTAGE	08990-SM-01	08990-SM-02	08990-SM-03	08990-SM-04	08990-SM-05	08990-SM-06	08990-SM-07	08990-SM-08	08990-SM-09	08990-SM-10	08990-SM-11	08990-SM-12	08990-SM-13	08990-SM-14	08990-SM-15



WEIGHT / MASSE: 8.6 Kg

QTY	MRK	DESCRIPTION	LENGTH	GRADE	REMARK	WEIGHT	QTY	MRK	DESCRIPTION	LENGTH	GRADE	REMARK	WEIGHT
QTÉ	MQE	DESCRIPTION	LONG.	NUANCE	REMARQUE	MASSE	QTÉ	MQE	DESCRIPTION	LONG.	NUANCE	REMARQUE	MASSE
1	P047	L 76 76 7.94	909	350W		8.6							

1	GRADE CHANGED/NUANCE CHANGÉE	2006/03/22
No	REVISION	DATE
	Pêches et Océans Canada	Fisheries and Oceans Canada
	Garde côtière	Coast Guard
	DESSIN MICHEL VACHON INC. DESSIN DE STRUCTURES MÉTALLIQUES TÉLÉPHONE: (418) 636-4386 TÉLÉCOPIEUR: (418) 636-7888	
STEEL TOWERS / TOURS D'ACIER		
MATERIAL:	G40.21M	Holes: 9/16" ø
MATÉRIEL:		TROUS: 9/16" ø
U.S. FINISH:		S.A. FINISH:
DATE:	2005/12/08	DATE:
DATE:	2005/12/08	DATE:
SCALE:	1 = 10	FILE:
ÉCHELLE:	1 = 10	DOSSIER:
		08990-SA
		DRAWING:
		DESSIN:
		P047

HEIGHT OF TOWER / HAUTEUR DE LA TOUR	10'	15'	20'	25'	30'	35'	40'	45'	50'	55'	60'	65'	70'	75'	80'
QUANTITY REQUIRED / QUANTITÉ REQUISE	1	1	1	1	1	1	1	1	1	1	1	1	1	1	1
ERECTION DRAWING / DESSIN DE MONTAGE	08990-SM-01	08990-SM-02	08990-SM-03	08990-SM-04	08990-SM-05	08990-SM-06	08990-SM-07	08990-SM-08	08990-SM-09	08990-SM-10	08990-SM-11	08990-SM-12	08990-SM-13	08990-SM-14	08990-SM-15

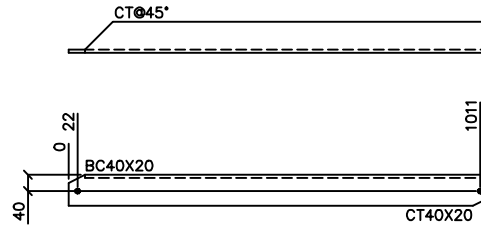

WEIGHT / MASSE: 9.7 Kg

QTY	MRK	DESCRIPTION	LENGTH	GRADE	REMARK	WEIGHT	QTY	MRK	DESCRIPTION	LENGTH	GRADE	REMARK	WEIGHT
QTÉ	MQE	DESCRIPTION	LONG.	NUANCE	REMARQUE	MASSE	QTÉ	MQE	DESCRIPTION	LONG.	NUANCE	REMARQUE	MASSE
1	P048	L 76 76 7.94	1033	350W	CLIP/CIS.	9.7							

1	GRADE CHANGED/NUANCE CHANGÉE	2006/03/22
No	REVISION	DATE
	Pêches et Océans Canada	Fisheries and Oceans Canada
	Garde côtière	Coast Guard
	DESSIN MICHEL VACHON INC. DESSIN DE STRUCTURES MÉTALLIQUES TÉLÉPHONE: (418) 638-6386 TÉLÉCOPIEUR: (418) 638-7888	
STEEL TOWERS / TOURS D'ACIER		
MATERIAL:	G40.21M	HOLES: 9/16" U.N. FINISH: GALV.
DESIGNÉ:	M. VACHON	CHECKED: M. VACHON DATE: 2005/12/08
SCALE: 1 = 10	FILE: 08990-SA	DRAWING: P048

HEIGHT OF TOWER / HAUTEUR DE LA TOUR	10'	15'	20'	25'	30'	35'	40'	45'	50'	55'	60'	65'	70'	75'	80'
QUANTITY REQUIRED / QUANTITÉ REQUISE	2	2	2	2	2	2	2	2	2	2	2	2	2	2	2
ERECTION DRAWING / DESSIN DE MONTAGE	08990-SM-01	08990-SM-02	08990-SM-03	08990-SM-04	08990-SM-05	08990-SM-06	08990-SM-07	08990-SM-08	08990-SM-09	08990-SM-10	08990-SM-11	08990-SM-12	08990-SM-13	08990-SM-14	08990-SM-15

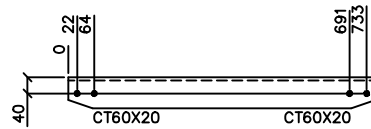

WEIGHT / MASSE: 7.1 Kg

QTY	MRK	DESCRIPTION	LENGTH	GRADE	REMARK	WEIGHT	QTY	MRK	DESCRIPTION	LENGTH	GRADE	REMARK	WEIGHT
QTÉ	MQE	DESCRIPTION	LONG.	NUANCE	REMARQUE	MASSE	QTÉ	MQE	DESCRIPTION	LONG.	NUANCE	REMARQUE	MASSE
1	P049	L 76 76 7.94	755	350W	CLIP/CIS.	7.1							

1	GRADE CHANGED/NUANCE CHANGÉE	2006/03/22			
No	REVISION	DATE			
	Pêches et Océans Canada	Fisheries and Oceans Canada			
	Garde côtière	Coast Guard			
	DESSIN MICHEL VACHON INC. DESSIN DE STRUCTURES MÉTALLIQUES TÉLÉPHONE: (418) 636-4386 TÉLÉCOPIEUR: (418) 636-7888				
STEEL TOWERS / TOURS D'ACIER					
MATERIAL:	G40.21M	HOLE:	9/16" ø	U.S. FINISH:	GALV.
DRAWN:	M.VACHON	CHECKED:	M.VACHON	DATE:	2005/12/08
SCALE:	1 = 10	FILE:	08990-SA	DRAWING:	P049
ÉCHELLE:		DOSSIER:		DESSIN:	

HEIGHT OF TOWER / HAUTEUR DE LA TOUR	10'	15'	20'	25'	30'	35'	40'	45'	50'	55'	60'	65'	70'	75'	80'
QUANTITY REQUIRED / QUANTITÉ REQUISE	1	1	1	1	1	1	1	1	1	1	1	1	1	1	1
ERECTION DRAWING / DESSIN DE MONTAGE	08990-SM-01	08990-SM-02	08990-SM-03	08990-SM-04	08990-SM-05	08990-SM-06	08990-SM-07	08990-SM-08	08990-SM-09	08990-SM-10	08990-SM-11	08990-SM-12	08990-SM-13	08990-SM-14	08990-SM-15

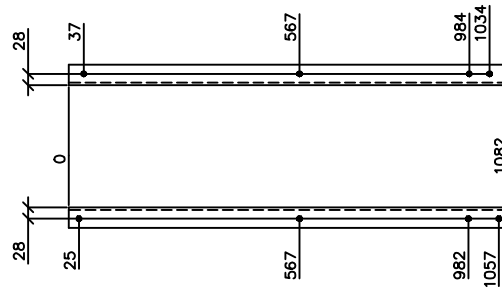

WEIGHT / MASSE: 5.3 Kg

QTY	MRK	DESCRIPTION	LENGTH	GRADE	REMARK	WEIGHT	QTY	MRK	DESCRIPTION	LENGTH	GRADE	REMARK	WEIGHT
QTÉ	MQE	DESCRIPTION	LONG.	NUANCE	REMARQUE	MASSE	QTÉ	MQE	DESCRIPTION	LONG.	NUANCE	REMARQUE	MASSE
1	P050	L 51 51	6.35	1082	350W	5.3							

1	GRADE CHANGED/NUANCE CHANGÉE	2006/03/22
No	REVISION	DATE
	Pêches et Océans Canada	Fisheries and Oceans Canada
	Garde côtière	Coast Guard
	DESSIN MICHEL VACHON INC. DESSIN DE STRUCTURES MÉTALLIQUES TÉLÉPHONE: (418) 636-4386 TÉLÉCOPIER: (418) 636-7988	
STEEL TOWERS / TOURS D'ACIER		
MATERIAL:	G40.21M	Holes: 9/16" ø
MATÉRIEL:		TROUS:
U.S. FINISH:		S.I. FINISH:
DATE:	2005/12/08	DATE:
DATE:		DATE:
FILE:	08990-SA	FILE:
DOSSIER:		DOSSIER:
SCALE:	1 = 10	SCALE:
ÉCHELLE:		ÉCHELLE:
DRAWING:	P050	DRAWING:
DESSIN:		DESSIN:

HEIGHT OF TOWER / HAUTEUR DE LA TOUR	10'	15'	20'	25'	30'	35'	40'	45'	50'	55'	60'	65'	70'	75'	80'
QUANTITY REQUIRED / QUANTITÉ REQUISE	1	1	1	1	1	1	1	1	1	1	1	1	1	1	1
ERECTION DRAWING / DESSIN DE MONTAGE	08990-SM-01	08990-SM-02	08990-SM-03	08990-SM-04	08990-SM-05	08990-SM-06	08990-SM-07	08990-SM-08	08990-SM-09	08990-SM-10	08990-SM-11	08990-SM-12	08990-SM-13	08990-SM-14	08990-SM-15

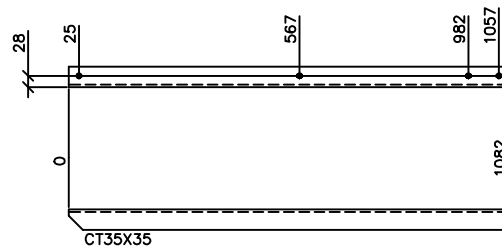

WEIGHT / MASSE: 5.3 Kg

QTY	MRK	DESCRIPTION			LENGTH	GRADE	REMARK	WEIGHT	QTY	MRK	DESCRIPTION			LENGTH	GRADE	REMARK	WEIGHT
QTÉ	MQE	DESCRIPTION			LONG.	NUANCE	REMARQUE	MASSE	QTÉ	MQE	DESCRIPTION			LONG.	NUANCE	REMARQUE	MASSE
1	P051	L	51	51	6.35	1082	350W	CLIP/CIS.	5.3								

1	GRADE CHANGED/NUANCE CHANGÉE	2006/03/22					
No	REVISION	DATE					
	Pêches et Océans Canada	Fisheries and Oceans Canada					
	Garde côtière	Coast Guard					
	DESSIN MICHEL VACHON INC. DESSIN DE STRUCTURES MÉTALLIQUES TÉLÉPHONE: (418) 636-4386 TÉLÉCOPIER: (418) 636-7888						
STEEL TOWERS / TOURS D'ACIER							
MATERIAL:	G40.21M	HOLE:	9/16" ø	U.N.:	S.N.	FINISH:	GALV.
MATÉRIEL:		TROUS:		U.N.:	S.N.	FINI:	
DRAWN:	M.VACHON	CHECKED:	M.VACHON	DATE:	2005/12/08		
DESSINÉ:		VÉRIFIÉ:		DATE:			
SCALE:	1 = 10	FILE:	08990-SA	DRAWING:	P051/1		
ÉCHELLE:		DOSSIER:		DESSIN:			

HEIGHT OF TOWER / HAUTEUR DE LA TOUR	10'	15'	20'	25'	30'	35'	40'	45'	50'	55'	60'	65'	70'	75'	80'
QUANTITY REQUIRED / QUANTITÉ REQUISE	1	1	1	1	1	1	1	1	1	1	1	1	1	1	1
ERECTION DRAWING / DESSIN DE MONTAGE	08990-SM-01	08990-SM-02	08990-SM-03	08990-SM-04	08990-SM-05	08990-SM-06	08990-SM-07	08990-SM-08	08990-SM-09	08990-SM-10	08990-SM-11	08990-SM-12	08990-SM-13	08990-SM-14	08990-SM-15



WEIGHT / MASSE: 3.2 Kg

QTY	MRK	DESCRIPTION		LENGTH	GRADE	REMARK	WEIGHT	QTY	MRK	DESCRIPTION		LENGTH	GRADE	REMARK	WEIGHT
QTÉ	MQE			LONG.	NUANCE	REMARQUE	MASSE	QTÉ	MQE			LONG.	NUANCE	REMARQUE	MASSE
1	P052	L	51 51	6.35	644	350W	3.2								

1	GRADE CHANGED/NUANCE CHANGÉE	2006/03/22					
No	REVISION	DATE					
	Pêches et Océans Canada	Fisheries and Oceans Canada					
	Garde côtière	Coast Guard					
	DESSIN MICHEL VACHON INC. DESSIN DE STRUCTURES MÉTALLIQUES TÉLÉPHONE: (418) 636-4386 TÉLÉCOPIER: (418) 636-7888						
STEEL TOWERS / TOURS D'ACIER							
MATERIAL:	G40.21M	HOLE:	9/16" ø	U.I.:	S.N.	FINISH:	GALV.
MATÉRIEL:		TROUS:		U.I.:	S.N.	FINISH:	
DRAWN:	M.VACHON	CHECKED:	M.VACHON	DATE:	2005/12/08		
DESSINÉ:		VÉRIFIÉ:		DATE:			
SCALE:	1 = 10	FILE:	08990-SA	DRAWING:	P052		
ÉCHELLE:		DOSSIER:		DESSIN:			

HEIGHT OF TOWER / HAUTEUR DE LA TOUR	10'	15'	20'	25'	30'	35'	40'	45'	50'	55'	60'	65'	70'	75'	80'
QUANTITY REQUIRED / QUANTITÉ REQUISE	1	1	1	1	1	1	1	1	1	1	1	1	1	1	1
ERECTION DRAWING / DESSIN DE MONTAGE	08990-SM-01	08990-SM-02	08990-SM-03	08990-SM-04	08990-SM-05	08990-SM-06	08990-SM-07	08990-SM-08	08990-SM-09	08990-SM-10	08990-SM-11	08990-SM-12	08990-SM-13	08990-SM-14	08990-SM-15

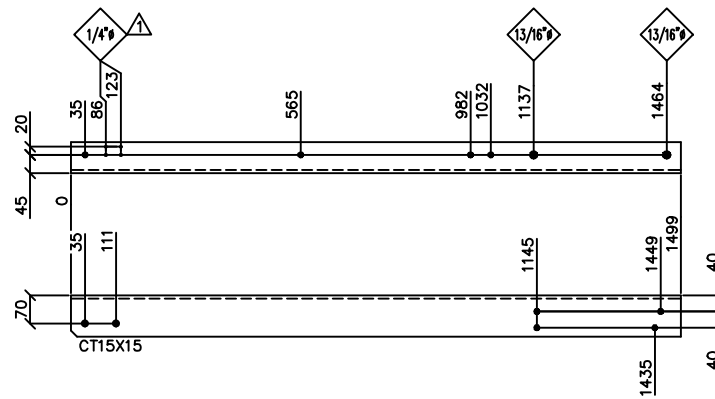

WEIGHT / MASSE: 16.6 Kg

QTY	MRK	DESCRIPTION	LENGTH	GRADE	REMARK	WEIGHT	QTY	MRK	DESCRIPTION	LENGTH	GRADE	REMARK	WEIGHT
QTÉ	MQE	DESCRIPTION	LONG.	NUANCE	REMARQUE	MASSE	QTÉ	MQE	DESCRIPTION	LONG.	NUANCE	REMARQUE	MASSE
1	P053	L 102 76 7.94	1499	350W	CLIP/CIS.	16.6							

2	GRADE CHANGED/NUANCE CHANGÉE	2006/03/22
1	HOLES ADDED/TROUS AJOUTÉS	2006/01/23
No	REVISION	DATE

 Pêches et Océans Canada
 Fisheries and Oceans Canada
 Garde côtière Coast Guard

 **DESSIN MICHEL VACHON INC.**
 DESSIN DE STRUCTURES MÉTALLIQUES
 TÉLÉPHONE: (418) 636-8386
 TÉLÉCOPIEUR: (418) 636-7888

STEEL TOWERS / TOURS D'ACIER

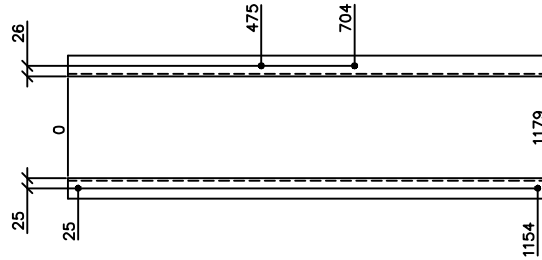

MATERIAL: G40.21M	HOLES: 9/16" Ø	U.S. FINISH: GALV.
MATÉRIEL:	TROUS:	S.N. FINI:
DRAWN: M. VACHON	CHECKED: M. VACHON	DATE: 2005/12/08
DESSINÉ:	VÉRIFIÉ:	DATE:
SCALE: 1 = 10	FILE: 08990-SA	DRAWING: P053/2
ÉCHELLE:	DOSSIER:	DESSIN:

HEIGHT OF TOWER / HAUTEUR DE LA TOUR	10'	15'	20'	25'	30'	35'	40'	45'	50'	55'	60'	65'	70'	75'	80'
QUANTITY REQUIRED / QUANTITÉ REQUISE	1	1	1	1	1	1	1	1	1	1	1	0	0	0	0
ERECTION DRAWING / DESSIN DE MONTAGE	08990-SM-01	08990-SM-02	08990-SM-03	08990-SM-04	08990-SM-05	08990-SM-06	08990-SM-07	08990-SM-08	08990-SM-09	08990-SM-10	08990-SM-11	08990-SM-12	08990-SM-13	08990-SM-14	08990-SM-15



WEIGHT / MASSE: 5.8 Kg

QTY	MRK	DESCRIPTION	LENGTH	GRADE	REMARK	WEIGHT	QTY	MRK	DESCRIPTION	LENGTH	GRADE	REMARK	WEIGHT
QTÉ	MQE	DESCRIPTION	LONG.	NUANCE	REMARQUE	MASSE	QTÉ	MQE	DESCRIPTION	LONG.	NUANCE	REMARQUE	MASSE
1	P054	L 51 51	6.35	1179	350W	5.8							

1	GRADE CHANGED/NUANCE CHANGÉE	2006/03/22				
No	REVISION	DATE				
	Pêches et Océans Canada	Fisheries and Oceans Canada				
	Garde côtière	Coast Guard				
	DESSIN MICHEL VACHON INC. DESSIN DE STRUCTURES MÉTALLIQUES TÉLÉPHONE: (418) 636-4386 TÉLÉCOPIER: (418) 636-7888					
STEEL TOWERS / TOURS D'ACIER						
MATERIAL: MATERIEL:	G40.21M	HOLE: TROUS:	9/16" ø	U.S. S.N.	FINISH: FINI:	GALV.
DRAWN: DESSINÉ:	M. VACHON	CHECKED: VÉRIFIÉ:	M. VACHON	DATE: DATE:	2005/12/08	
SCALE: ÉCHELLE:	1 = 10	FILE: DOSSIER:	08990-SA	DRAWING: DESSIN:	P054 / 	

HEIGHT OF TOWER / HAUTEUR DE LA TOUR	10'	15'	20'	25'	30'	35'	40'	45'	50'	55'	60'	65'	70'	75'	80'
QUANTITY REQUIRED / QUANTITÉ REQUISE	1	1	1	1	1	1	1	1	1	1	1	0	0	0	0
ERECTION DRAWING / DESSIN DE MONTAGE	08990-SM-01	08990-SM-02	08990-SM-03	08990-SM-04	08990-SM-05	08990-SM-06	08990-SM-07	08990-SM-08	08990-SM-09	08990-SM-10	08990-SM-11	08990-SM-12	08990-SM-13	08990-SM-14	08990-SM-15

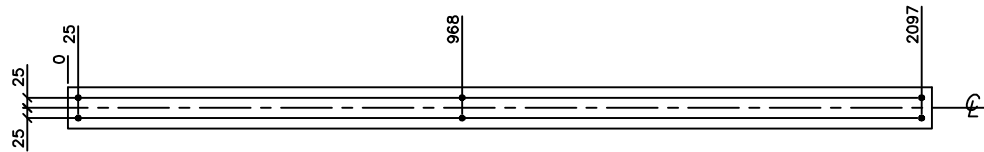

WEIGHT / MASSE: 11.1 Kg

QTY	MRK	DESCRIPTION			LENGTH	GRADE	REMARK	WEIGHT	QTY	MRK	DESCRIPTION			LENGTH	GRADE	REMARK	WEIGHT
QTÉ	MQE				LONG.	NUANCE	REMARQUE	MASSE	QTÉ	MQE			LONG.	NUANCE	REMARQUE	MASSE	
1	P056	FB	6.35	X	102	2122	300W	11.1									

-	-	-
No	REVISION	DATE
	Pêches et Océans Canada	Fisheries and Oceans Canada
	Garde côtière	Coast Guard
	DESSIN MICHEL VACHON INC. DESSIN DE STRUCTURES MÉTALLIQUES TÉLÉPHONE: (418) 636-8386 TÉLÉCOPIEUR: (418) 636-7888	
STEEL TOWERS / TOURS D'ACIER		
MATERIAL: MATÉRIEL:	G40.21M	HOLE: TROUS:
DRAWN: DESSINÉ:	M. VACHON	CHECKED: VÉRIFIÉ:
SCALE: ÉCHELLE:	1 = 10	DATE: DATE:
		FILE: DOSSIER:
		DRAWING: DESSIN:

HEIGHT OF TOWER / HAUTEUR DE LA TOUR	10'	15'	20'	25'	30'	35'	40'	45'	50'	55'	60'	65'	70'	75'	80'
QUANTITY REQUIRED / QUANTITÉ REQUISE	1	1	1	1	1	1	1	1	1	1	1	0	0	0	0
ERECTION DRAWING / DESSIN DE MONTAGE	08990-SM-01	08990-SM-02	08990-SM-03	08990-SM-04	08990-SM-05	08990-SM-06	08990-SM-07	08990-SM-08	08990-SM-09	08990-SM-10	08990-SM-11	08990-SM-12	08990-SM-13	08990-SM-14	08990-SM-15

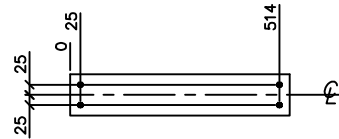

WEIGHT / MASSE: 2.8 Kg

QTY	MRK	DESCRIPTION			LENGTH	GRADE	REMARK	WEIGHT	QTY	MRK	DESCRIPTION			LENGTH	GRADE	REMARK	WEIGHT
QTÉ	MQE	DESCRIPTION	LONG.	NUANCE	REMARQUE	MASSE	QTÉ	MQE	DESCRIPTION	LONG.	NUANCE	REMARQUE	MASSE				
1	P058	FB 6.35 X 102	539	300W		2.8											

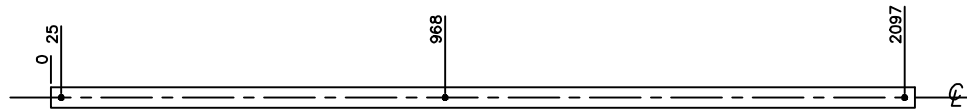

-	-	-					
No	REVISION	DATE					
	Pêches et Océans Canada	Fisheries and Oceans Canada					
	Garde côtière	Coast Guard					
 DESSIN MICHEL VACHON INC. DESSIN DE STRUCTURES MÉTALLIQUES TÉLÉPHONE: (418) 636-4386 TÉLÉCOPIEUR: (418) 636-7988							
STEEL TOWERS / TOURS D'ACIER							
MATERIAL:	G40.21M	HOLE:	9/16" ⌀	U.I.:	S.N.	FINISH:	GALV.
DRAWN:	M.VACHON	CHECKED:	M.VACHON	DATE:	2005/12/08		
SCALE:	1 = 10	FILE:	08990-SA	DRAWING:	P058 / 0		

HEIGHT OF TOWER / HAUTEUR DE LA TOUR	10'	15'	20'	25'	30'	35'	40'	45'	50'	55'	60'	65'	70'	75'	80'
QUANTITY REQUIRED / QUANTITÉ REQUISE	1	1	1	1	1	1	1	1	1	1	1	0	0	0	0
ERECTION DRAWING / DESSIN DE MONTAGE	08990-SM-01	08990-SM-02	08990-SM-03	08990-SM-04	08990-SM-05	08990-SM-06	08990-SM-07	08990-SM-08	08990-SM-09	08990-SM-10	08990-SM-11	08990-SM-12	08990-SM-13	08990-SM-14	08990-SM-15



WEIGHT / MASSE: 5.6 Kg

QTY QTÉ	MRK MQE	DESCRIPTION	LENGTH LONG.	GRADE NUANCE	REMARK REMARQUE	WEIGHT MASSE	QTY QTÉ	MRK MQE	DESCRIPTION	LENGTH LONG.	GRADE NUANCE	REMARK REMARQUE	WEIGHT MASSE
1	P059	FB 6.35 X 51	2122	300W		5.6							

-	-	-
No	REVISION	DATE
	Pêches et Océans Canada	Fisheries and Oceans Canada
	Garde côtière	Coast Guard
	DESSIN MICHEL VACHON INC. DESSIN DE STRUCTURES MÉTALLIQUES TÉLÉPHONE: (418) 636-8386 TÉLÉCOPIER: (418) 636-7888	
STEEL TOWERS / TOURS D'ACIER		
MATERIAL: MATÉRIEL:	G40.21M	HOLE: TROUS:
DRAWN: DESSINÉ:	M. VACHON	CHECKED: VÉRIFIÉ:
SCALE: ÉCHELLE:	1 = 10	DATE: DATE:
		FILE: DOSSIER:
		DRAWING: DESSIN:
		2005/12/08
		08990-SA
		P059 / 

HEIGHT OF TOWER / HAUTEUR DE LA TOUR	10'	15'	20'	25'	30'	35'	40'	45'	50'	55'	60'	65'	70'	75'	80'
QUANTITY REQUIRED / QUANTITÉ REQUISE	1	1	1	1	1	1	1	1	1	1	1	1	1	1	1
ERECTION DRAWING / DESSIN DE MONTAGE	08990-SM-01	08990-SM-02	08990-SM-03	08990-SM-04	08990-SM-05	08990-SM-06	08990-SM-07	08990-SM-08	08990-SM-09	08990-SM-10	08990-SM-11	08990-SM-12	08990-SM-13	08990-SM-14	08990-SM-15



WEIGHT / MASSE: 3.1 Kg

QTY	MRK	DESCRIPTION	LENGTH	GRADE	REMARK	WEIGHT	QTY	MRK	DESCRIPTION	LENGTH	GRADE	REMARK	WEIGHT
QTÉ	MQE	DESCRIPTION	LONG.	NUANCE	REMARQUE	MASSE	QTÉ	MQE	DESCRIPTION	LONG.	NUANCE	REMARQUE	MASSE
1	P060	FB 6.35 X 51	1179	300W		3.1							

-	-	-					
No	REVISION	DATE					
	Pêches et Océans Canada	Fisheries and Oceans Canada					
	Garde côtière	Coast Guard					
	DESSIN MICHEL VACHON INC. DESSIN DE STRUCTURES MÉTALLIQUES TÉLÉPHONE: (418) 636-4386 TÉLÉCOPIER: (418) 636-7888						
STEEL TOWERS / TOURS D'ACIER							
MATERIAL:	G40.21M	HOLE:	9/16" ø	U.N.:	S.N.	FINISH:	GALV.
DRAWN:	M. VACHON	CHECKED:	M. VACHON	DATE:	2005/12/08		
SCALE:	1 = 10	FILE:	08990-SA	DRAWING:	P060 /		
ÉCHELLE:		DOSSIER:		DESSIN:			

HEIGHT OF TOWER / HAUTEUR DE LA TOUR	10'	15'	20'	25'	30'	35'	40'	45'	50'	55'	60'	65'	70'	75'	80'
QUANTITY REQUIRED / QUANTITÉ REQUISE	1	1	1	1	1	1	1	1	1	1	1	0	0	0	0
ERECTION DRAWING / DESSIN DE MONTAGE	08990-SM-01	08990-SM-02	08990-SM-03	08990-SM-04	08990-SM-05	08990-SM-06	08990-SM-07	08990-SM-08	08990-SM-09	08990-SM-10	08990-SM-11	08990-SM-12	08990-SM-13	08990-SM-14	08990-SM-15



WEIGHT / MASSE: 1.4 Kg

QTY	MRK	DESCRIPTION			LENGTH	GRADE	REMARK	WEIGHT	QTY	MRK	DESCRIPTION			LENGTH	GRADE	REMARK	WEIGHT
QTÉ	MQE	DESCRIPTION	LONG.	NUANCE	REMARQUE	MASSE	QTÉ	MQE	DESCRIPTION	LONG.	NUANCE	REMARQUE	MASSE				
1	P062	FB	6.35	X	51	539	300W	1.4									

-	-	-					
No	REVISION	DATE					
	Pêches et Océans Canada	Fisheries and Oceans Canada					
	Garde côtière	Coast Guard					
DESSIN MICHEL VACHON INC. DESSIN DE STRUCTURES MÉTALLIQUES TÉLÉPHONE: (418) 636-8386 TÉLÉCOPIEUR: (418) 636-7888							
STEEL TOWERS / TOURS D'ACIER							
MATERIAL:	G40.21M	HOLE:	9/16" ø	U.I.:	SIN.	FINISH:	GALV.
DRAWN:	M.VACHON	CHECKED:	M.VACHON	DATE:	2005/12/08		
SCALE:	1 = 10	FILE:	08990-SA	DRAWING:	P062 /		
ÉCHELLE:		DOSSIER:		DESSIN:			

HEIGHT OF TOWER / HAUTEUR DE LA TOUR	10'	15'	20'	25'	30'	35'	40'	45'	50'	55'	60'	65'	70'	75'	80'
QUANTITY REQUIRED / QUANTITÉ REQUISE	2	2	2	2	2	2	2	2	2	2	2	2	2	2	2
ERECTION DRAWING / DESSIN DE MONTAGE	08990-SM-01	08990-SM-02	08990-SM-03	08990-SM-04	08990-SM-05	08990-SM-06	08990-SM-07	08990-SM-08	08990-SM-09	08990-SM-10	08990-SM-11	08990-SM-12	08990-SM-13	08990-SM-14	08990-SM-15

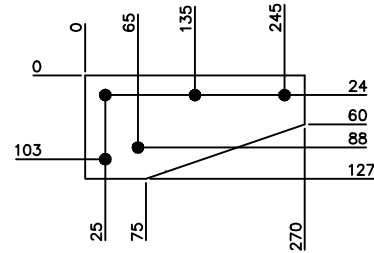

WEIGHT / MASSE: 2.1 Kg

QTY	MRK	DESCRIPTION	LENGTH	GRADE	REMARK	WEIGHT	QTY	MRK	DESCRIPTION	LENGTH	GRADE	REMARK	WEIGHT
QTÉ	MQE	DESCRIPTION	LONG.	NUANCE	REMARQUE	MASSE	QTÉ	MQE	DESCRIPTION	LONG.	NUANCE	REMARQUE	MASSE
1	P069	FB 9.53 X	127	270	300W	2.1							

-	-	-					
No	REVISION	DATE					
	Pêches et Océans Canada	Fisheries and Oceans Canada					
	Garde côtière	Coast Guard					
	DESSIN MICHEL VACHON INC. DESSIN DE STRUCTURES MÉTALLIQUES TÉLÉPHONE: (418) 636-8386 TÉLÉCOPIEUR: (418) 636-7888						
STEEL TOWERS / TOURS D'ACIER							
MATERIAL:	G40.21M	HOLE:	9/16" ø	U.N.:	S.N.	FINISH:	GALV.
MATÉRIEL:		TROUS:		U.N.:	S.N.	FINI:	
DRAWN:	M. VACHON	CHECKED:	M. VACHON	DATE:	2005/12/08		
DESSINÉ:		VÉRIFIÉ:		DATE:			
SCALE:	1 = 5	FILE:	DOSSIER:	08990-SA	DRAWING:	DESSIN:	P069 / 0
ÉCHELLE:		DOSSIER:					

HEIGHT OF TOWER / HAUTEUR DE LA TOUR	10'	15'	20'	25'	30'	35'	40'	45'	50'	55'	60'	65'	70'	75'	80'
QUANTITY REQUIRED / QUANTITÉ REQUISE	1	2	3	4	5	6	7	8	9	10	11	12	13	14	15
ERECTION DRAWING / DESSIN DE MONTAGE	08990-SM-01	08990-SM-02	08990-SM-03	08990-SM-04	08990-SM-05	08990-SM-06	08990-SM-07	08990-SM-08	08990-SM-09	08990-SM-10	08990-SM-11	08990-SM-12	08990-SM-13	08990-SM-14	08990-SM-15

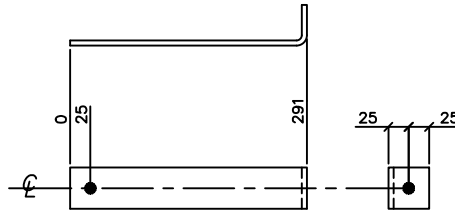

WEIGHT / MASSE: 0.9 Kg

QTY	MRK	DESCRIPTION	LENGTH	GRADE	REMARK	WEIGHT	QTY	MRK	DESCRIPTION	LENGTH	GRADE	REMARK	WEIGHT
QTÉ	MQE	DESCRIPTION	LONG.	NUANCE	REMARQUE	MASSE	QTÉ	MQE	DESCRIPTION	LONG.	NUANCE	REMARQUE	MASSE
1	E081	FB 6.35 X 51	331	300W		0.9							

1	NOUVELLE DÉSIGNATION	2006/01/19					
No	REVISION	DATE					
	Pêches et Océans Canada Garde côtière	Fisheries and Oceans Canada Coast Guard					
	DESSIN MICHEL VACHON INC. DESSIN DE STRUCTURES MÉTALLIQUES TÉLÉPHONE: (418) 636-8386 TÉLÉCOPIEUR: (418) 636-7888						
	STEEL TOWERS / TOURS D'ACIER						
MATERIAL:	G40.21M	HOLE:	9/16" ø	U.N.:	S.N.	FINISH:	GALV.
DRAWN:	M.VACHON	CHECKED:	M.VACHON	DATE:	2005/12/14		
DESSINÉ:	M.VACHON	VÉRIFIÉ:	M.VACHON	DATE:	2005/12/14		
SCALE:	1 = 5	FILE:	DOSSIER:	08990-SA	DRAWING:	E081/A	
ÉCHELLE:	1 = 5	DOSSIER:	08990-SA		DESSIN:	E081/A	

HEIGHT OF TOWER / HAUTEUR DE LA TOUR	10'	15'	20'	25'	30'	35'	40'	45'	50'	55'	60'	65'	70'	75'	80'
QUANTITY REQUIRED / QUANTITÉ REQUISE	1	2	3	4	5	6	7	8	9	10	11	0	0	0	0
ERECTION DRAWING / DESSIN DE MONTAGE	08990-SM-01	08990-SM-02	08990-SM-03	08990-SM-04	08990-SM-05	08990-SM-06	08990-SM-07	08990-SM-08	08990-SM-09	08990-SM-10	08990-SM-11	08990-SM-12	08990-SM-13	08990-SM-14	08990-SM-15

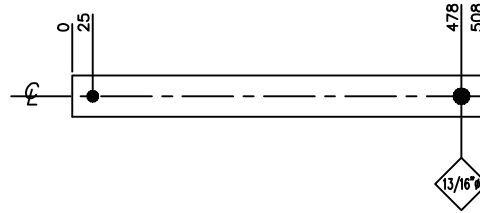

WEIGHT / MASSE: 1.3 Kg

QTY QTÉ	MRK MQE	DESCRIPTION	LENGTH LONG.	GRADE NUANCE	REMARK REMARQUE	WEIGHT MASSE	QTY QTÉ	MRK MQE	DESCRIPTION	LENGTH LONG.	GRADE NUANCE	REMARK REMARQUE	WEIGHT MASSE
1	E082	FB 6.35 X 51	508	300W		1.3							

1	NOUVELLE DÉSIGNATION	2006/01/19				
No	REVISION	DATE				
	Pêches et Océans Canada	Fisheries and Oceans Canada				
	Garde côtière	Coast Guard				
	DESSIN MICHEL VACHON INC. DESSIN DE STRUCTURES MÉTALLIQUES TÉLÉPHONE: (418) 636-4386 TÉLÉCOPIER: (418) 636-7888					
STEEL TOWERS / TOURS D'ACIER						
MATERIAL: MATÉRIEL:	G40.21M	HOLE: TROUS:	9/16" ø	U.N. S.N.	FINISH: FINI:	GALV.
DRAWN: DESSINÉ:	M. VACHON	CHECKED: VÉRIFIÉ:	M. VACHON	DATE: DATE:	2005/12/14	
SCALE: ÉCHELLE:	1 = 5	FILE: DOSSIER:	08990-SA	DRAWING: DESSIN:	E082 / A	

HEIGHT OF TOWER / HAUTEUR DE LA TOUR	10'	15'	20'	25'	30'	35'	40'	45'	50'	55'	60'	65'	70'	75'	80'
QUANTITY REQUIRED / QUANTITÉ REQUISE	1	2	3	4	5	6	7	8	9	10	11	12	13	14	15
ERECTION DRAWING / DESSIN DE MONTAGE	08990-SM-01	08990-SM-02	08990-SM-03	08990-SM-04	08990-SM-05	08990-SM-06	08990-SM-07	08990-SM-08	08990-SM-09	08990-SM-10	08990-SM-11	08990-SM-12	08990-SM-13	08990-SM-14	08990-SM-15

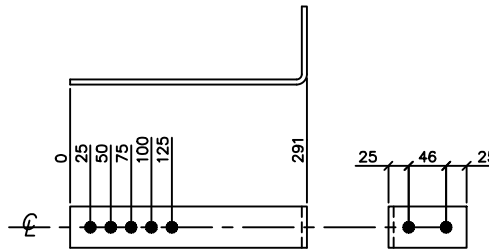

WEIGHT / MASSE: 1.0 Kg

QTY	MRK	DESCRIPTION	LENGTH	GRADE	REMARK	WEIGHT	QTY	MRK	DESCRIPTION	LENGTH	GRADE	REMARK	WEIGHT
QTÉ	MQE	DESCRIPTION	LONG.	NUANCE	REMARQUE	MASSE	QTÉ	MQE	DESCRIPTION	LONG.	NUANCE	REMARQUE	MASSE
1	M083	FB 6.35 X 51	377	300W		1.0							

-	-	-
No	REVISION	DATE
	Pêches et Océans Canada	Fisheries and Oceans Canada
	Garde côtière	Coast Guard
	DESSIN MICHEL VACHON INC. DESSIN DE STRUCTURES MÉTALLIQUES TÉLÉPHONE: (418) 636-8386 TÉLÉCOPIEUR: (418) 636-7888	
STEEL TOWERS / TOURS D'ACIER		
MATERIAL: MATÉRIEL:	G40.21M	HOLE: TROUS:
DRAWN: DESSINÉ:	M. VACHON	CHECKED: VÉRIFIÉ:
SCALE: ÉCHELLE:	1 = 5	FILE: DOSSIER:
		DATE: DATE:
		DRAWING: DESSIN:
		M083 /
		FINISH: FINI:
		GALV.
		2005/12/14
		08990-SA

HEIGHT OF TOWER / HAUTEUR DE LA TOUR	10'	15'	20'	25'	30'	35'	40'	45'	50'	55'	60'	65'	70'	75'	80'
QUANTITY REQUIRED / QUANTITÉ REQUISE	1	1	1	1	1	1	1	1	1	1	1	2	2	2	2
ERECTION DRAWING / DESSIN DE MONTAGE	08990-SM-01	08990-SM-02	08990-SM-03	08990-SM-04	08990-SM-05	08990-SM-06	08990-SM-07	08990-SM-08	08990-SM-09	08990-SM-10	08990-SM-11	08990-SM-12	08990-SM-13	08990-SM-14	08990-SM-15

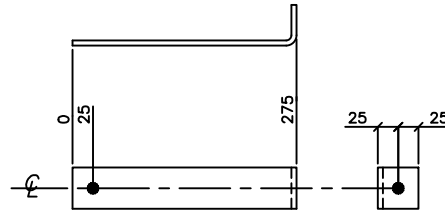

WEIGHT / MASSE: 0.8 Kg

QTY	MRK	DESCRIPTION			LENGTH	GRADE	REMARK	WEIGHT	QTY	MRK	DESCRIPTION			LENGTH	GRADE	REMARK	WEIGHT
QTÉ	MQE	DESCRIPTION	LONG.	NUANCE	REMARQUE	MASSE	QTÉ	MQE	DESCRIPTION	LONG.	NUANCE	REMARQUE	MASSE				
1	E084	FB 6.35 X 51	315	300W		0.8											

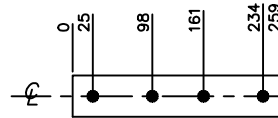

1	NOUVELLE DÉSIGNATION	2006/01/19					
No	REVISION	DATE					
	Pêches et Océans Canada	Fisheries and Oceans Canada					
	Garde côtière	Coast Guard					
	DESSIN MICHEL VACHON INC. DESSIN DE STRUCTURES MÉTALLIQUES TÉLÉPHONE: (418) 636-8386 TÉLÉCOPIER: (418) 636-7988						
STEEL TOWERS / TOURS D'ACIER							
MATERIAL:	G40.21M	HOLE:	9/16" ø	U.N.:	S.N.	FINISH:	GALV.
DRAWN:	M.VACHON	CHECKED:	M.VACHON	DATE:	2005/12/14		
DESSINÉ:	M.VACHON	VÉRIFIÉ:	M.VACHON	DATE:	2005/12/14		
SCALE:	1 = 5	FILE:	DOSSIER:	08990-SA	DRAWING:	DESIGN:	E084
ÉCHELLE:	1 = 5	DOSSIER:	08990-SA		DESIGN:	E084	

HEIGHT OF TOWER / HAUTEUR DE LA TOUR	10'	15'	20'	25'	30'	35'	40'	45'	50'	55'	60'	65'	70'	75'	80'
QUANTITY REQUIRED / QUANTITÉ REQUISE	0	2	2	4	4	6	6	8	8	10	10	12	12	14	14
ERECTION DRAWING / DESSIN DE MONTAGE	08990-SM-01	08990-SM-02	08990-SM-03	08990-SM-04	08990-SM-05	08990-SM-06	08990-SM-07	08990-SM-08	08990-SM-09	08990-SM-10	08990-SM-11	08990-SM-12	08990-SM-13	08990-SM-14	08990-SM-15



WEIGHT / MASSE: 0.7 Kg

QTY	MRK	DESCRIPTION			LENGTH	GRADE	REMARK	WEIGHT	QTY	MRK	DESCRIPTION			LENGTH	GRADE	REMARK	WEIGHT
QTÉ	MQE				LONG.	NUANCE	REMARQUE	MASSE	QTÉ	MQE			LONG.	NUANCE	REMARQUE	MASSE	
1	E086	FB	6.35	X	51	259	300W	0.7									

1	NOUVELLE DÉSIGNATION	2006/01/19				
No	REVISION	DATE				
	Pêches et Océans Canada	Fisheries and Oceans Canada				
	Garde côtière	Coast Guard				
	DESSIN MICHEL VACHON INC. DESSIN DE STRUCTURES MÉTALLIQUES TÉLÉPHONE: (418) 636-8386 TÉLÉCOPIER: (418) 636-7888					
STEEL TOWERS / TOURS D'ACIER						
MATERIAL: MATÉRIEL:	G40.21M	HOLE: TROUS:	9/16" ø	U.N. S.N.	FINISH: FINI:	GALV.
DRAWN: DESSINÉ:	M. VACHON	CHECKED: VÉRIFIÉ:	M. VACHON	DATE:	2005/12/14	
SCALE: ÉCHELLE:	1 = 5	FILE: DOSSIER:	08990-SA	DRAWING: DESSIN:	E086 / A	

HEIGHT OF TOWER / HAUTEUR DE LA TOUR	10'	15'	20'	25'	30'	35'	40'	45'	50'	55'	60'	65'	70'	75'	80'
QUANTITY REQUIRED / QUANTITÉ REQUISE	1	1	1	1	1	1	1	1	1	1	1	1	1	1	1
ERECTION DRAWING / DESSIN DE MONTAGE	08990-SM-01	08990-SM-02	08990-SM-03	08990-SM-04	08990-SM-05	08990-SM-06	08990-SM-07	08990-SM-08	08990-SM-09	08990-SM-10	08990-SM-11	08990-SM-12	08990-SM-13	08990-SM-14	08990-SM-15

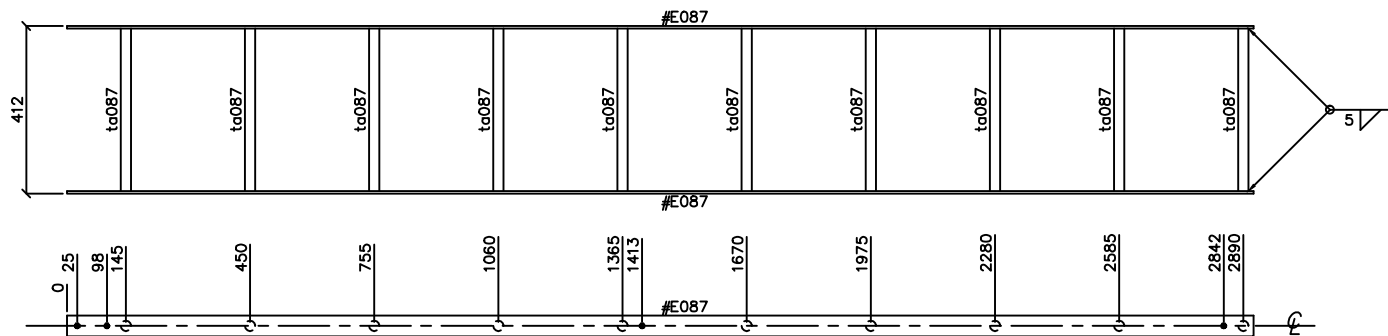

WEIGHT / MASSE: 31.7 Kg

QTY	MRK	DESCRIPTION	LENGTH	GRADE	REMARK	WEIGHT	QTY	MRK	DESCRIPTION	LENGTH	GRADE	REMARK	WEIGHT
QTE	MQE	DESCRIPTION	LONG.	NUANCE	REMARQUE	MASSE	QTE	MQE	DESCRIPTION	LONG.	NUANCE	REMARQUE	MASSE
2	E087	FB 6.35 X 51	2915	300W	ASS. #E087	15.3							
10	ta087	● 25.4 ø X	399	300W		16.4							

-	-	-
No	REVISION	DATE
	Pêches et Océans Canada	Fisheries and Oceans Canada
	Garde côtière	Coast Guard
DESSIN MICHEL VACHON INC. DESSIN DE STRUCTURES METALLIQUES TELEPHONE: (418) 638-8388 TELECOPIEUR: (418) 638-7888		
STEEL TOWERS / TOURS D'ACIER		
MATERIAL: G40.21M	HOLES: 9/16" ø	U.N. FINISH: GALV.
DRAWN: M. VACHON	CHECKED: M. VACHON	DATE: 2005/12/15
SCALE: 1 = 10	FILE: 08990-SA	DRAWING: E087

HEIGHT OF TOWER / HAUTEUR DE LA TOUR	10'	15'	20'	25'	30'	35'	40'	45'	50'	55'	60'	65'	70'	75'	80'
QUANTITY REQUIRED / QUANTITÉ REQUISE	0	0	1	1	2	2	3	3	4	4	5	5	6	6	7
ERECTION DRAWING / DESSIN DE MONTAGE	08990-SM-01	08990-SM-02	08990-SM-03	08990-SM-04	08990-SM-05	08990-SM-06	08990-SM-07	08990-SM-08	08990-SM-09	08990-SM-10	08990-SM-11	08990-SM-12	08990-SM-13	08990-SM-14	08990-SM-15

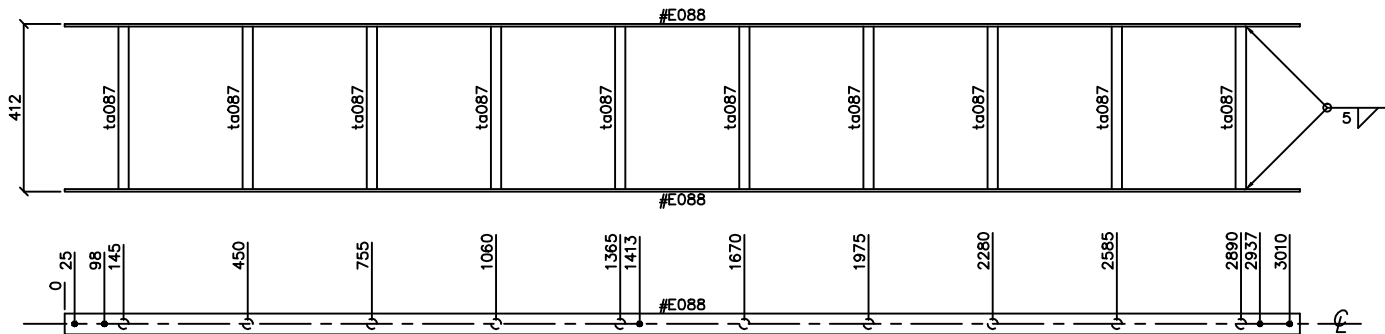

WEIGHT / MASSE: 32.3 Kg

QTY	MRK	DESCRIPTION	LENGTH	GRADE	REMARK	WEIGHT	QTY	MRK	DESCRIPTION	LENGTH	GRADE	REMARK	WEIGHT
QTÉ	MQE	DESCRIPTION	LONG.	NUANCE	REMARQUE	MASSE	QTÉ	MQE	DESCRIPTION	LONG.	NUANCE	REMARQUE	MASSE
2	E088	FB 6.35 X 51	3035	300W	ASS. #E088	15.9							
10	ta087	● 25.4 Ø X	399	300W		16.4							

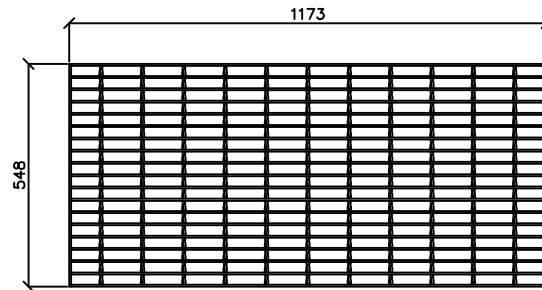

-	-	-
No	REVISION	DATE
	Pêches et Océans Canada	Fisheries and Oceans Canada
	Garde côtière	Coast Guard
	DESSIN MICHEL VACHON INC. DESSIN DE STRUCTURES MÉTALLIQUES TÉLÉPHONE: (418) 638-8386 TÉLÉCOPIER: (418) 638-7988	
STEEL TOWERS / TOURS D'ACIER		
MATERIAL:	G40.21M	HOLE:
MATÉRIEL:		TROUS:
U.S. FINISH:		S.I. FINISH:
DATE:	2005/12/15	DATE:
DATE:		DATE:
SCALE:	1 = 10	FILE:
ÉCHELLE:		DOSSIER:
		08990-SA
		DESSIN:
		E088

HEIGHT OF TOWER / HAUTEUR DE LA TOUR	10'	15'	20'	25'	30'	35'	40'	45'	50'	55'	60'	65'	70'	75'	80'
QUANTITY REQUIRED / QUANTITÉ REQUISE	1	1	1	1	1	1	1	1	1	1	1	0	0	0	0
ERECTION DRAWING / DESSIN DE MONTAGE	08990-SM-01	08990-SM-02	08990-SM-03	08990-SM-04	08990-SM-05	08990-SM-06	08990-SM-07	08990-SM-08	08990-SM-09	08990-SM-10	08990-SM-11	08990-SM-12	08990-SM-13	08990-SM-14	08990-SM-15



WEIGHT / MASSE: 28.8 Kg

QTY	MRK	DESCRIPTION	LENGTH	GRADE	REMARK	WEIGHT	QTY	MRK	DESCRIPTION	LENGTH	GRADE	REMARK	WEIGHT
QTÉ	MQE	DESCRIPTION	LONG.	NUANCE	REMARQUE	MASSE	QTÉ	MQE	DESCRIPTION	LONG.	NUANCE	REMARQUE	MASSE
1	P090	GRA.	4.76	31.8	548	1173	30-102	SERRATED/DENTELÉ					28.8

-	-	-
No	REVISION	DATE
	Pêches et Océans Canada	Fisheries and Oceans Canada
	Garde côtière	Coast Guard
	DESSIN MICHEL VACHON INC. DESSIN DE STRUCTURES MÉTALLIQUES TÉLÉPHONE: (418) 636-8386 TÉLÉCOPIEUR: (418) 636-7988	
STEEL TOWERS / TOURS D'ACIER		
MATERIAL: MATÉRIEL:	G40.21M	H.OLES: TROUS:
U.N. S.N.	-	FINISH: FINI:
		GALV.
DRAWN: DESSINÉ:	M. VACHON	CHECKED: VÉRIFIÉ:
		M. VACHON
SCALE: ÉCHELLE:	1 = 10	DATE: DATE:
		2005/12/15
FILE: DOSSIER:	08990-SA	DRAWING: DESSIN:
		P090

HEIGHT OF TOWER / HAUTEUR DE LA TOUR	10'	15'	20'	25'	30'	35'	40'	45'	50'	55'	60'	65'	70'	75'	80'
QUANTITY REQUIRED / QUANTITÉ REQUISE	1	1	1	1	1	1	1	1	1	1	1	0	0	0	0
ERECTION DRAWING / DESSIN DE MONTAGE	08990-SM-01	08990-SM-02	08990-SM-03	08990-SM-04	08990-SM-05	08990-SM-06	08990-SM-07	08990-SM-08	08990-SM-09	08990-SM-10	08990-SM-11	08990-SM-12	08990-SM-13	08990-SM-14	08990-SM-15

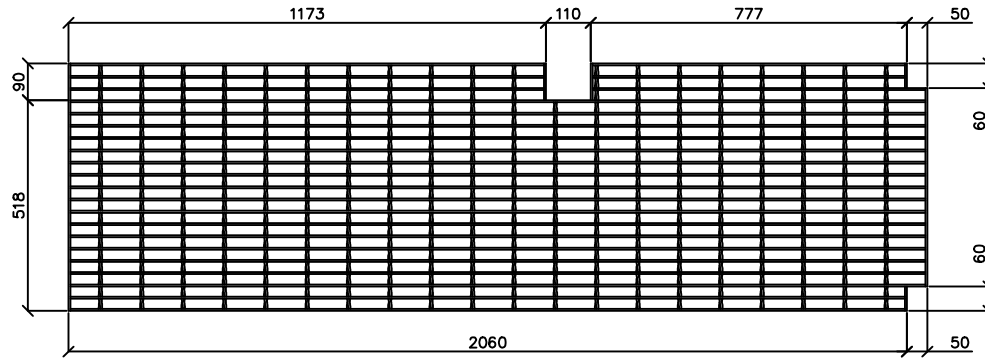

WEIGHT / MASSE: 57.5 Kg

QTY QTÉ	MRK MQE	DESCRIPTION	LENGTH LONG.	GRADE NUANCE	REMARK REMARQUE	WEIGHT MASSE	QTY QTÉ	MRK MQE	DESCRIPTION	LENGTH LONG.	GRADE NUANCE	REMARK REMARQUE	WEIGHT MASSE
1	P091	GRA.	4.76	31.8	608	2110	30-102	SERRATED/DENTELÉ					57.5

-	-	-
No	REVISION	DATE
	Pêches et Océans Canada	Fisheries and Oceans Canada
	Garde côtière	Coast Guard
	DESSIN MICHEL VACHON INC. DESSIN DE STRUCTURES MÉTALLIQUES TÉLÉPHONE: (418) 636-8386 TÉLÉCOPIEUR: (418) 636-7988	
STEEL TOWERS / TOURS D'ACIER		
MATERIAL: MATÉRIEL:	G40.21M	HOLES: TROUS:
DRAWN: DESSINÉ:	M. VACHON	CHECKED: VÉRIFIÉ:
SCALE: ÉCHELLE:	1 = 10	DATE: DATE:
		FILE: DOSSIER:
		DRAWING: DESSIN:
		2005/12/15
		P091

HEIGHT OF TOWER / HAUTEUR DE LA TOUR	10'	15'	20'	25'	30'	35'	40'	45'	50'	55'	60'	65'	70'	75'	80'
QUANTITY REQUIRED / QUANTITÉ REQUISE	1	1	1	1	1	0	0	0	0	0	0	0	0	0	0
ERECTION DRAWING / DESSIN DE MONTAGE	08990-SM-01	08990-SM-02	08990-SM-03	08990-SM-04	08990-SM-05	08990-SM-06	08990-SM-07	08990-SM-08	08990-SM-09	08990-SM-10	08990-SM-11	08990-SM-12	08990-SM-13	08990-SM-14	08990-SM-15

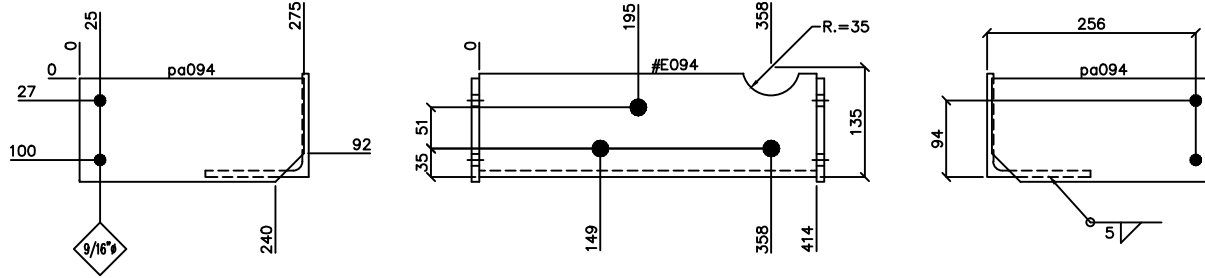

2	GRADE CHANGED/NUANCE CHANGÉE	2006/03/22
1	NEW MARK/NOUVELLE MARQUE	2006/01/23

No	REVISION	DATE
	Pêches et Océans / Fisheries and Oceans Canada	
	Garde côtière / Coast Guard	

WEIGHT / MASSE: 12.0 Kg

QTY	MRK	DESCRIPTION	LENGTH	GRADE	REMARK	WEIGHT	QTY	MRK	DESCRIPTION	LENGTH	GRADE	REMARK	WEIGHT
QTÉ	MQE	DESCRIPTION	LONG.	NUANCE	REMARQUE	MASSE	QTÉ	MQE	DESCRIPTION	LONG.	NUANCE	REMARQUE	MASSE
1	E094	L 127 127	7.94	414	350W	6.6							
2	pa094	FB 9.53 X 127	275	300W	ASS. #E094	5.4							

DESSIN MICHEL VACHON INC.
DESSIN DE STRUCTURES MÉTALLIQUES
TÉLÉPHONE: (418) 636-8386
TÉLÉCOPIER: (418) 636-7988

STEEL TOWERS / TOURS D'ACIER

MATERIAL: G40.21M	HOLES: 13/16" Ø	U.S. FINISH: GALV.
DRAWN: M. VACHON	CHECKED: M. VACHON	DATE: 2005/12/15
SCALE: 1 = 5	FILE: 08990-SA	DRAWING: E094

HEIGHT OF TOWER / HAUTEUR DE LA TOUR	10'	15'	20'	25'	30'	35'	40'	45'	50'	55'	60'	65'	70'	75'	80'
QUANTITY REQUIRED / QUANTITÉ REQUISE	0	0	0	0	0	0	0	1	1	1	1	0	0	0	0
ERECTION DRAWING / DESSIN DE MONTAGE	08990-SM-01	08990-SM-02	08990-SM-03	08990-SM-04	08990-SM-05	08990-SM-06	08990-SM-07	08990-SM-08	08990-SM-09	08990-SM-10	08990-SM-11	08990-SM-12	08990-SM-13	08990-SM-14	08990-SM-15

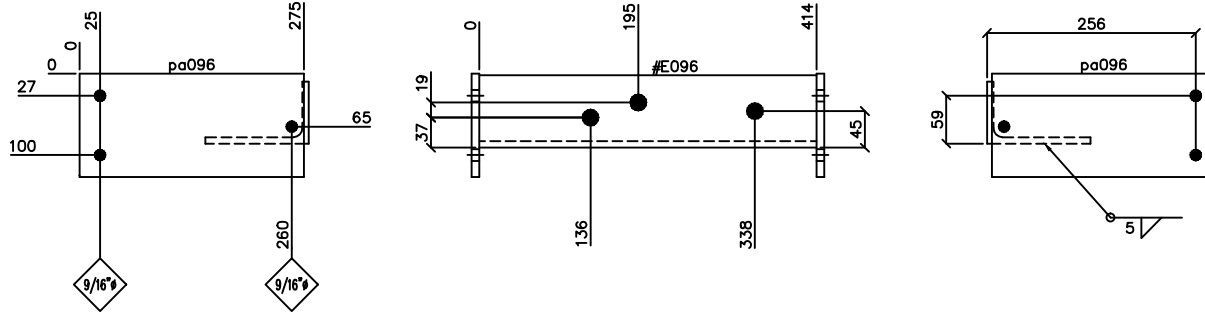

WEIGHT / MASSE: 10.9 Kg

QTY	MRK	DESCRIPTION	LENGTH	GRADE	REMARK	WEIGHT	QTY	MRK	DESCRIPTION	LENGTH	GRADE	REMARK	WEIGHT
QTÉ	MQE	DESCRIPTION	LONG.	NUANCE	REMARQUE	MASSE	QTÉ	MQE	DESCRIPTION	LONG.	NUANCE	REMARQUE	MASSE
1	E096	L 127 89	7.94	414	ASS. #E096	5.5							
2	pa096	FB 9.53 X 127	275	300W		5.4							

2	GRADE CHANGED/NUANCE CHANGÉE	2006/03/22					
1	NEW MARK/NOUVELLE MARQUE	2006/01/23					
No	REVISION	DATE					
Pêches et Océans Canada		Fisheries and Oceans Canada					
Garde côtière		Coast Guard					
DESSIN MICHEL VACHON INC. DESSIN DE STRUCTURES MÉTALLIQUES TÉLÉPHONE: (418) 636-8386 TÉLÉCOPIER: (418) 636-7988							
STEEL TOWERS / TOURS D'ACIER							
MATERIAL:	G40.21M	HOLE:	13/16" ø	U.I.:	S.N.	FINISH:	GALV.
DRAWN:	M. VACHON	CHECKED:	M. VACHON	DATE:	2005/12/16		
SCALE:	1 = 5	FILE:	DOSSIER:	08990-SA	DRAWING:	E096 / 2	

HEIGHT OF TOWER / HAUTEUR DE LA TOUR	10'	15'	20'	25'	30'	35'	40'	45'	50'	55'	60'	65'	70'	75'	80'
QUANTITY REQUIRED / QUANTITÉ REQUISE	0	4	4	8	8	12	12	16	16	20	20	24	24	28	28
ERECTION DRAWING / DESSIN DE MONTAGE	08990-SM-01	08990-SM-02	08990-SM-03	08990-SM-04	08990-SM-05	08990-SM-06	08990-SM-07	08990-SM-08	08990-SM-09	08990-SM-10	08990-SM-11	08990-SM-12	08990-SM-13	08990-SM-14	08990-SM-15

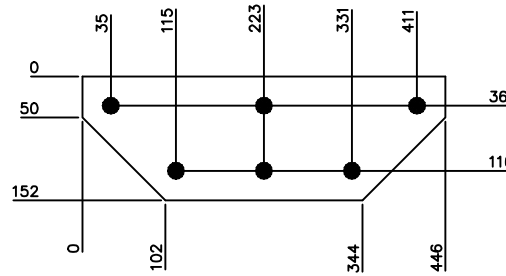

WEIGHT / MASSE: 4.5 Kg

QTY	MRK	DESCRIPTION	LENGTH	GRADE	REMARK	WEIGHT	QTY	MRK	DESCRIPTION	LENGTH	GRADE	REMARK	WEIGHT
QTÉ	MQE	DESCRIPTION	LONG.	NUANCE	REMARQUE	MASSE	QTÉ	MQE	DESCRIPTION	LONG.	NUANCE	REMARQUE	MASSE
1	M100	FB 9.53 X	152	446	300W	4.5							

-	-	-
No	REVISION	DATE
	Pêches et Océans Canada	Fisheries and Oceans Canada
	Garde côtière	Coast Guard
	DESSIN MICHEL VACHON INC. DESSIN DE STRUCTURES MÉTALLIQUES TÉLÉPHONE: (418) 636-8386 TÉLÉCOPIER: (418) 636-7988	
STEEL TOWERS / TOURS D'ACIER		
MATERIAL: MATÉRIEL:	G40.21M	HOLE: TROUS:
DRAWN: DESSINÉ:	M.VACHON	CHECKED: VÉRIFIÉ:
SCALE: ÉCHELLE:	1 = 5	FILE: DOSSIER:
		DATE: DATE:
		DRAWING: DESSIN:
		M100 /
		FINISH: FINI:
		GALV.

HEIGHT OF TOWER / HAUTEUR DE LA TOUR	10'	15'	20'	25'	30'	35'	40'	45'	50'	55'	60'	65'	70'	75'	80'
QUANTITY REQUIRED / QUANTITÉ REQUISE	6	6	6	6	6	6	6	6	6	6	6	0	0	0	0
ERECTION DRAWING / DESSIN DE MONTAGE	08990-SM-01	08990-SM-02	08990-SM-03	08990-SM-04	08990-SM-05	08990-SM-06	08990-SM-07	08990-SM-08	08990-SM-09	08990-SM-10	08990-SM-11	08990-SM-12	08990-SM-13	08990-SM-14	08990-SM-15

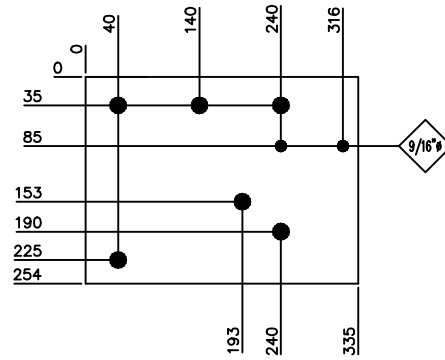

WEIGHT / MASSE: 6.6 Kg

QTY QTÉ	MRK MQE	DESCRIPTION	LENGTH LONG.	GRADE NUANCE	REMARK REMARQUE	WEIGHT MASSE	QTY QTÉ	MRK MQE	DESCRIPTION	LENGTH LONG.	GRADE NUANCE	REMARK REMARQUE	WEIGHT MASSE
1	M101	FB 9.53 X 254	335	300W		6.6							

-	-	-
No	REVISION	DATE
	Pêches et Océans Canada	Fisheries and Oceans Canada
	Garde côtière	Coast Guard
	DESSIN MICHEL VACHON INC. DESSIN DE STRUCTURES MÉTALLIQUES TÉLÉPHONE: (418) 636-4386 TÉLÉCOPIEUR: (418) 636-7888	
STEEL TOWERS / TOURS D'ACIER		
MATERIAL: MATÉRIEL:	G40.21M	HOLE: TROUS:
DRW: DESSINÉ:	M.VACHON	CHECKED: VÉRIFIÉ:
SCALE: ÉCHELLE:	1 = 5	FILE: DOSSIER:
		DATE: DATE:
		DRAWING: DESSIN:
		M101 /
		GALV.
		2005/12/16
		08990-SA

HEIGHT OF TOWER / HAUTEUR DE LA TOUR	10'	15'	20'	25'	30'	35'	40'	45'	50'	55'	60'	65'	70'	75'	80'
QUANTITY REQUIRED / QUANTITÉ REQUISE	7	7	7	7	7	7	7	7	7	7	7	0	0	0	0
ERECTION DRAWING / DESSIN DE MONTAGE	08990-SM-01	08990-SM-02	08990-SM-03	08990-SM-04	08990-SM-05	08990-SM-06	08990-SM-07	08990-SM-08	08990-SM-09	08990-SM-10	08990-SM-11	08990-SM-12	08990-SM-13	08990-SM-14	08990-SM-15

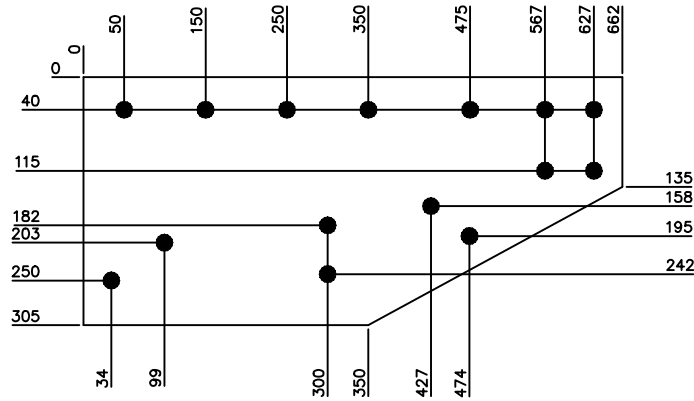

WEIGHT / MASSE: 13.6 Kg

QTY	MRK	DESCRIPTION	LENGTH	GRADE	REMARK	WEIGHT	QTY	MRK	DESCRIPTION	LENGTH	GRADE	REMARK	WEIGHT
QTÉ	MQE	DESCRIPTION	LONG.	NUANCE	REMARQUE	MASSE	QTÉ	MQE	DESCRIPTION	LONG.	NUANCE	REMARQUE	MASSE
1	M102	FB 9.53 X 305	662	300W		13.6							

-	-	-
No	REVISION	DATE
	Pêches et Océans Canada	Fisheries and Oceans Canada
	Garde côtière	Coast Guard
	DESSIN MICHEL VACHON INC. DESSIN DE STRUCTURES MÉTALLIQUES TÉLÉPHONE: (418) 636-4386 TÉLÉCOPIER: (418) 636-7888	
STEEL TOWERS / TOURS D'ACIER		
MATERIAL: MATERIEL:	G40.21M	HOLES: TROUS:
DRAWN: DESSINÉ:	M.VACHON	CHECKED: VÉRIFIÉ:
SCALE: ÉCHELLE:	1 = 5	FILE: DOSSIER:
		DATE: DATE:
		DRAWING: DESSIN:
		M102 /
		FINISH: FINI:
		GALV.

HEIGHT OF TOWER / HAUTEUR DE LA TOUR	10'	15'	20'	25'	30'	35'	40'	45'	50'	55'	60'	65'	70'	75'	80'
QUANTITY REQUIRED / QUANTITÉ REQUISE	0	8	16	24	32	32	32	32	32	32	32	0	0	0	0
ERECTION DRAWING / DESSIN DE MONTAGE	08990-SM-01	08990-SM-02	08990-SM-03	08990-SM-04	08990-SM-05	08990-SM-06	08990-SM-07	08990-SM-08	08990-SM-09	08990-SM-10	08990-SM-11	08990-SM-12	08990-SM-13	08990-SM-14	08990-SM-15

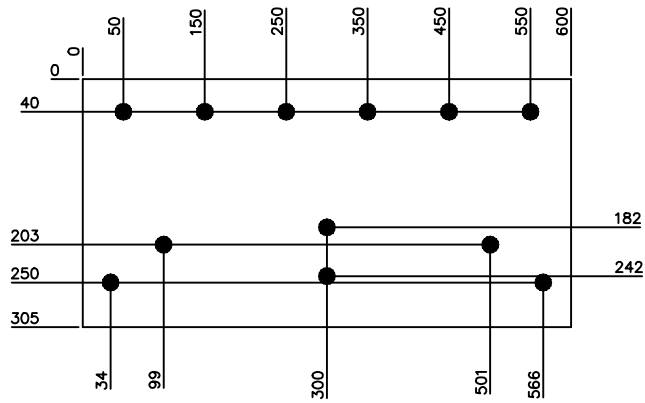

WEIGHT / MASSE: 14.2 Kg

QTY	MRK	DESCRIPTION			LENGTH	GRADE	REMARK	WEIGHT	QTY	MRK	DESCRIPTION			LENGTH	GRADE	REMARK	WEIGHT
QTÉ	MQE				LONG.	NUANCE	REMARQUE	MASSE	QTÉ	MQE			LONG.	NUANCE	REMARQUE	MASSE	
1	M103	FB	9.53	X	305	600	300W	14.2									

-	-	-					
No	REVISION	DATE					
	Pêches et Océans Canada	Fisheries and Oceans Canada					
	Garde côtière	Coast Guard					
	DESSIN MICHEL VACHON INC. DESSIN DE STRUCTURES MÉTALLIQUES TÉLÉPHONE: (418) 636-8386 TÉLÉCOPIER: (418) 636-7888						
STEEL TOWERS / TOURS D'ACIER							
MATERIAL:	G40.21M	HOLE:	13/16" ø	U.I.:	S.N.	FINISH:	GALV.
DRAWN:	M.VACHON	CHECKED:	M.VACHON	DATE:	2005/12/16		
SCALE:	1 = 5	FILE:	DOSSIER:	08990-SA	DRAWING:	DESSIN: M103 / 10	

HEIGHT OF TOWER / HAUTEUR DE LA TOUR	10'	15'	20'	25'	30'	35'	40'	45'	50'	55'	60'	65'	70'	75'	80'
QUANTITY REQUIRED / QUANTITÉ REQUISE	0	0	0	0	0	8	8	8	8	8	8	0	0	0	0
ERECTION DRAWING / DESSIN DE MONTAGE	08990-SM-01	08990-SM-02	08990-SM-03	08990-SM-04	08990-SM-05	08990-SM-06	08990-SM-07	08990-SM-08	08990-SM-09	08990-SM-10	08990-SM-11	08990-SM-12	08990-SM-13	08990-SM-14	08990-SM-15

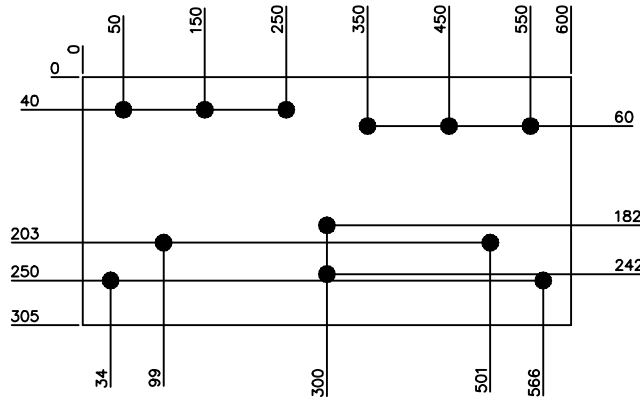

WEIGHT / MASSE: 14.2 Kg

QTY	MRK	DESCRIPTION	LENGTH	GRADE	REMARK	WEIGHT	QTY	MRK	DESCRIPTION	LENGTH	GRADE	REMARK	WEIGHT
QTÉ	MQE	DESCRIPTION	LONG.	NUANCE	REMARQUE	MASSE	QTÉ	MQE	DESCRIPTION	LONG.	NUANCE	REMARQUE	MASSE
1	M104	FB 9.53 X 305	600	300W		14.2							

-	-	-
No	REVISION	DATE
	Pêches et Océans Canada	Fisheries and Oceans Canada
	Garde côtière	Coast Guard
	DESSIN MICHEL VACHON INC. DESSIN DE STRUCTURES MÉTALLIQUES TÉLÉPHONE: (418) 636-4386 TÉLÉCOPIER: (418) 636-7888	
STEEL TOWERS / TOURS D'ACIER		
MATERIAL: MATERIEL:	G40.21M	HOLES: TROUS:
DRAWN: DESSINÉ:	M.VACHON	CHECKED: VÉRIFIÉ:
SCALE: ÉCHELLE:	1 = 5	FILE: DOSSIER:
		DATE: DATE:
		DRAWING: DESSIN:
		M104

HEIGHT OF TOWER / HAUTEUR DE LA TOUR	10'	15'	20'	25'	30'	35'	40'	45'	50'	55'	60'	65'	70'	75'	80'
QUANTITY REQUIRED / QUANTITÉ REQUISE	0	0	0	0	0	0	8	8	16	16	24	0	0	0	0
ERECTION DRAWING / DESSIN DE MONTAGE	08990-SM-01	08990-SM-02	08990-SM-03	08990-SM-04	08990-SM-05	08990-SM-06	08990-SM-07	08990-SM-08	08990-SM-09	08990-SM-10	08990-SM-11	08990-SM-12	08990-SM-13	08990-SM-14	08990-SM-15

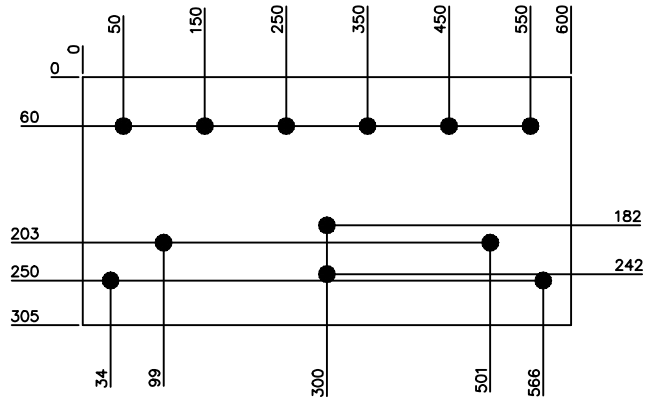

WEIGHT / MASSE: 14.2 Kg

QTY	MRK	DESCRIPTION			LENGTH	GRADE	REMARK	WEIGHT	QTY	MRK	DESCRIPTION			LENGTH	GRADE	REMARK	WEIGHT
QTÉ	MQE	FB	9.53	X	LONG.	NUANCE	REMARQUE	MASSE	QTÉ	MQE	FB	9.53	X	LONG.	NUANCE	REMARQUE	MASSE
1	M105	FB	9.53	X	305	600	300W	14.2									

-	-	-			
No	REVISION	DATE			
	Pêches et Océans Canada	Fisheries and Oceans Canada			
	Garde côtière	Coast Guard			
	DESSIN MICHEL VACHON INC. DESSIN DE STRUCTURES MÉTALLIQUES TÉLÉPHONE: (418) 636-8386 TÉLÉCOPIER: (418) 636-7888				
STEEL TOWERS / TOURS D'ACIER					
MATERIAL:	G40.21M	HOLE:	13/16" ø	U.S. FINISH:	GALV.
MATÉRIEL:		TROUS:		S.N. FINI:	
DRAWN:	M.VACHON	CHECKED:	M.VACHON	DATE:	2005/12/16
DESSINÉ:		VÉRIFIÉ:		DATE:	
SCALE:	1 = 5	FILE:	08990-SA	DRAWING:	M105
ÉCHELLE:		DOSSIER:		DESSIN:	

HEIGHT OF TOWER / HAUTEUR DE LA TOUR	10'	15'	20'	25'	30'	35'	40'	45'	50'	55'	60'	65'	70'	75'	80'
QUANTITY REQUIRED / QUANTITÉ REQUISE	0	0	0	0	0	0	0	8	8	8	8	0	0	0	0
ERECTION DRAWING / DESSIN DE MONTAGE	08990-SM-01	08990-SM-02	08990-SM-03	08990-SM-04	08990-SM-05	08990-SM-06	08990-SM-07	08990-SM-08	08990-SM-09	08990-SM-10	08990-SM-11	08990-SM-12	08990-SM-13	08990-SM-14	08990-SM-15

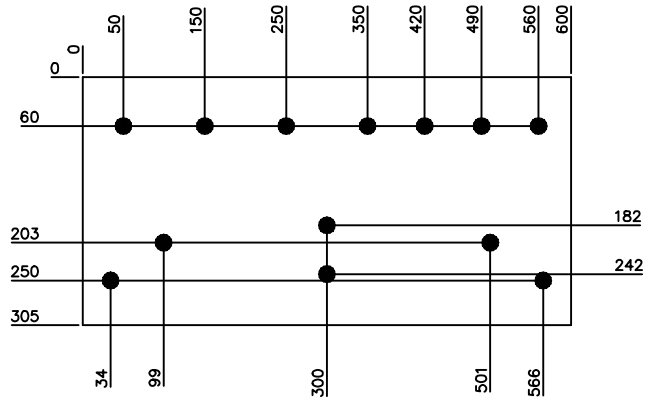

WEIGHT / MASSE: 14.2 Kg

QTY	MRK	DESCRIPTION			LENGTH	GRADE	REMARK	WEIGHT	QTY	MRK	DESCRIPTION			LENGTH	GRADE	REMARK	WEIGHT
QTÉ	MQE				LONG.	NUANCE	REMARQUE	MASSE	QTÉ	MQE			LONG.	NUANCE	REMARQUE	MASSE	
1	M106	FB	9.53	X	305	600	300W	14.2									

-	-	-				
No	REVISION	DATE				
	Pêches et Océans Canada	Fisheries and Oceans Canada				
	Garde côtière	Coast Guard				
	DESSIN MICHEL VACHON INC. DESSIN DE STRUCTURES MÉTALLIQUES TÉLÉPHONE: (418) 636-4386 TÉLÉCOPIER: (418) 636-7888					
STEEL TOWERS / TOURS D'ACIER						
MATERIAL:	G40.21M	HOLE:	13/16" ø	U.S. S.N.	FINISH:	GALV.
DRAWN:	M.VACHON	CHECKED:	M.VACHON	DATE:	2005/12/16	
SCALE:	1 = 5	FILE:	DOSSIER:	08990-SA	DRAWING:	M106 /

HEIGHT OF TOWER / HAUTEUR DE LA TOUR	10'	15'	20'	25'	30'	35'	40'	45'	50'	55'	60'	65'	70'	75'	80'
QUANTITY REQUIRED / QUANTITÉ REQUISE	1	1	1	1	1	1	1	1	1	1	1	0	0	0	0
ERECTION DRAWING / DESSIN DE MONTAGE	08990-SM-01	08990-SM-02	08990-SM-03	08990-SM-04	08990-SM-05	08990-SM-06	08990-SM-07	08990-SM-08	08990-SM-09	08990-SM-10	08990-SM-11	08990-SM-12	08990-SM-13	08990-SM-14	08990-SM-15

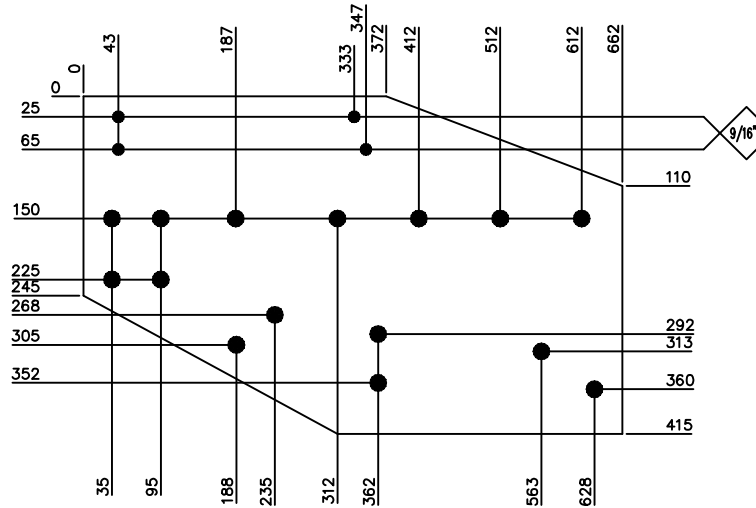

WEIGHT / MASSE: 18.0 Kg

QTY QTÉ	MRK MQE	DESCRIPTION	LENGTH LONG.	GRADE NUANCE	REMARK REMARQUE	WEIGHT MASSE	QTY QTÉ	MRK MQE	DESCRIPTION	LENGTH LONG.	GRADE NUANCE	REMARK REMARQUE	WEIGHT MASSE
1	M108	PL 9.53 X	415	662	300W	18.0							

-	-	-				
No	REVISION	DATE				
	Pêches et Océans Canada	Fisheries and Oceans Canada				
	Garde côtière	Coast Guard				
	DESSIN MICHEL VACHON INC. DESSIN DE STRUCTURES MÉTALLIQUES TÉLÉPHONE: (418) 636-8386 TÉLÉCOPIER: (418) 636-7988					
STEEL TOWERS / TOURS D'ACIER						
MATERIAL: MATÉRIEL:	G40.21M	HOLE: TROUS:	13/16" ø	U.S. S.N.	FINISH: FINI:	GALV.
DRAWN: DESSINÉ:	M. VACHON	CHECKED: VÉRIFIÉ:	M. VACHON	DATE:	2005/12/16	
SCALE: ÉCHELLE:	1 = 5	FILE: DOSSIER:	08990-SA	DRAWING: DESSIN:	M108 /	



Fisheries and Oceans
Canada

Pêches et Océans
Canada

Canadian
Coast Guard

Garde côtière
canadienne



APPENDIX B4 – GEOTECHNICAL INVESTIGATION REPORT



Geotechnical Investigation Proposed Aid to Navigation (ATON) Towers, LL 503 Oshawa Harbour Range Towers (Proposed FR and RR) Harbour Road, Oshawa, Ontario

Maritime and Civil Infrastructure, Integrated Technical Services

Central & Arctic Region

Canadian Coast Guard

Fisheries and Oceans Canada

520 Exmouth Street

Sarnia, Ontario N7T 8B1

May 11, 2016

65 Sunray Street, Whitby, Ontario, Canada

L1N 8Y3

11114483| 01 | Report No. 1

Table of Contents

1.	Introduction	1
2.	Purpose and Scope	1
3.	Field and Laboratory Procedures	2
4.	Subsurface Conditions	3
4.1	General	3
4.2	Borehole BH-1 (Proposed RR)	3
4.2.1	Topsoil	3
4.2.2	Silty Sand	3
4.2.3	Clayey Silt	4
4.2.4	Till	4
4.2.5	Groundwater	4
4.2.6	Inferred Bedrock / Practical Refusal	4
4.3	Borehole BH-2 (Proposed FR)	5
4.3.1	Topsoil	5
4.3.2	Fill	5
4.3.3	Peat	5
4.3.4	Silty Sand	5
4.3.5	Groundwater	5
5.	Discussion and Recommendations	6
5.1	General	6
5.2	Excavations and Groundwater Control	6
5.2.1	Excavations	6
5.2.2	Dewatering	7
5.3	Backfilling	7
5.4	Foundation Recommendations	7
5.4.1	Driven Steel Pile Foundation	8
5.4.2	Cast-in-Place Concrete Pile Foundation	8
5.4.3	Helical Pile	9
5.4.4	Adfreeze Forces	9
5.4.5	Lateral Pile Capacity	10
5.4.6	General Pile Recommendations	10
5.5	Seismic Site Class	11
5.6	Corrosion Potential	11
5.7	General Recommendations	13
5.7.1	Further Exploration	13
5.7.2	Subsoil Sensitivity	13
5.7.3	Winter Construction	13
5.7.4	Design Review and Construction Inspections	13
6.	Statement of Limitations	14

Enclosures

PLAN NO. 1 Test Hole Location Plan

Appendices

Appendix A: Borehole Logs

Appendix B: Physical Laboratory Data

Appendix C: Chemical Laboratory Data

1. Introduction

GHD Limited (GHD) has been retained by the Department of Fisheries and Oceans Canada (DFO, the Client) to conduct a geotechnical investigation for the Aid to Navigation (ATON) structures proposed to be installed at LL 503 – Oshawa Harbor Proposed Range Towers FR and RR in Oshawa, Ontario.

The authorization for the geotechnical investigation was provided through the DFO Purchase Order No. F2563-150056 dated February 24, 2016.

It is our understanding that the Sites are located onshore in Oshawa, Ontario, west of Farewell Street and north/south of Harbour Road, with coordinates as follows:

-) 43° 52' 11.74"N, 78° 49' 35.35"W (Proposed FR); and
-) 43° 52' 23.81"N, 78° 49' 45.49"W (Proposed RR).

Based on the Client's RFQ, it is our understanding that they intend to erect new ATON tower structures at both these locations, and that the towers will both be approximately 18m (60ft) latticed steel towers. GHD has reviewed the set of drawings provided in Appendix B of the RFQ. A review of the drawings indicate the tower will be supported on one of three foundations (depending on the ground conditions encountered): either cast-in-place concrete base slab founded on a compacted crushed stone pad, or additionally utilizing helical screw piles or dywidag micropiles advanced into bedrock.

2. Purpose and Scope

The purpose of the geotechnical investigation is to evaluate the subsurface soil and groundwater conditions to aid in the design of the proposed ATON structure foundations. The information contained herein must in no way be construed as an opinion of this site's environmental status.

The following scope of work was performed in order to accomplish the foregoing purposes.

1. Underground utility clearance at the borehole locations through Ontario One Call and a private utility locator prior to commencement of field geotechnical investigation program.
2. Drilling of two (2) boreholes to depths of 13.7 and 12.2 metres below existing grade (mbeg) using either a track mounted drill rig equipped with continuous flight solid stem augers and Standard Penetration Test (SPT) equipment, or a dynamic ram sounder equipped with SPT equipment;
3. Soil sampling using SPT sampling technique carried out in accordance with ASTM - D1586. SPT 'N'-values will be recorded during drilling. Sampling frequency to be 0.75 m interval up to 3 m bgs and 1.52 m depth interval thereafter, or as dictated by field conditions;
4. Field classification of all split spoon samples obtained by qualified geotechnical staff in accordance with ASTM D2488. Spilt spoon samples from borehole to be stored in air-tight containers;
5. Recording groundwater depth upon its first occurrence and upon completion of the borehole. Long term groundwater monitoring is beyond the scope of this investigation.

6. Physical laboratory analysis of soil samples was carried out including grain size analysis and moisture content tests.
7. Chemical analysis of soil samples was performed, testing for parameters related to corrosivity, consisting of pH, resistivity, redox potential, chlorides, sulphates, and sulfides.
8. The ground at the borehole locations was reinstated as close as possible to its original condition upon completion of the fieldwork. Abandonment of completed borehole with auger cuttings and bentonite pellets in accordance with the Ontario Regulation 903. Excess soil cuttings were stockpiled at the borehole location or spread around in its vicinity.
9. Geotechnical engineering analysis of acquired field and laboratory data have been compiled in this report outlining our findings, conclusions, and geotechnical engineering recommendations.

3. Field and Laboratory Procedures

A field investigation was conducted under the supervision of GHD staff on March 8 and 28, 2016. The work consisted of subsurface exploration by means of advancing and sampling a total of two (2) exploratory boreholes to depths of approximately 13.7 mbeg (BH-1) and 12.2 mbeg (BH-2).

A detailed log of each borehole was maintained and representative samples of the materials encountered in the boreholes were collected. A detailed log of each borehole is presented in Appendix A.

The boreholes were installed under the full time supervision of GHD's geotechnical representative, who logged the boreholes and observed groundwater conditions during and upon completion of the boreholes. Disturbed samples of the strata penetrated were obtained utilizing a 50 mm diameter split barrel sampler at depths intervals of no greater than 0.76 m up to 3 m bgs, and at no greater than 1.5 m depth intervals thereafter. The split-barrel sampler was advanced by dropping a 63.5 kg hammer from a height of 760 mm, in accordance with the standard penetration test (SPT) method as described in the American Society for Testing and Materials (ASTM) standard ASTM D1586. The results of SPT, reported as Penetration Index 'N' values are recorded on the borehole log, provided in Appendix B, at the corresponding depths. Borehole BH-1 was terminated at 13.7 mbeg due to split spoon and auger refusal. Borehole BH-2 was terminated at 12.2 mbeg in compact native soil.

Soil samples obtained from the boreholes were inspected in the field immediately upon retrieval for type, texture, and colour. All test holes were backfilled following completion of the fieldwork, in accordance with O.Reg. 903. All soil samples were sealed in clean plastic containers. All samples were transported to the GHD laboratory for further visual-tactile examination, and to select appropriate samples for laboratory analysis.

Groundwater measurements and observations were obtained from the open boreholes during the drilling operations. Groundwater data is presented on individual borehole logs.

Physical laboratory testing was completed on soil samples, and consisted of moisture content tests on all samples recovered and gradation analyses / hydrometers on a total of two (2) representative soil samples. The analytical results of the moisture content tests are plotted on the attached logs. The results of the gradation testing are incorporated into the borehole logs, and are presented graphically in Appendix B.

Chemical testing was performed by submitting two (2) soil samples for chemical properties to determine the potential for corrosion of buried steel structures and potential of sulphate attack on below-grade concrete structures. The soil samples were submitted under chain-of-custody to Caduceon Environmental Laboratories (CEL), an accredited laboratory by the Canadian Association for Laboratory Accreditation CALA. The samples were tested for pH, resistivity, redox potential, chlorides, sulphates, and sulfides. The analytical test results are discussed in Section 5.7 and the laboratory test result sheets are provided in Appendix C.

4. Subsurface Conditions

4.1 General

Based on our knowledge of the regional geology, the general subsurface conditions in the area are consist of overburden sand, silt, and clay. A review of the bedrock geology and the available water well record in the vicinity of the site indicates that the bedrock in the surrounding area is in the order of 10 m to 20m below the natural grades, and typically consists of shale or limestone bedrock.

Details of the subsurface conditions encountered at the sites are presented graphically on the borehole logs (Appendix A). It should be noted that the boundaries between the strata have been inferred from the borehole observations and non-continuous samples. They generally represent a transition from one soil type to another, and should not be inferred to represent an exact plane of geological change. Further, conditions may vary between and beyond the boreholes.

The boreholes encountered a surficial layer of topsoil over either native soils (BH-1) or fill (BH-2) overlying bedrock (inferred from practical refusal to further auger advancement in BH-1 at about 13.7 mbeg). Groundwater was encountered in the boreholes at depths of 1.2 mbeg and 1.5 mbeg (BH-1 and BH-2 respectively).

The following sections describe the major soil strata and subsurface conditions encountered during this investigation in more detail.

4.2 Borehole BH-1 (Proposed RR)

4.2.1 Topsoil

Both boreholes encountered a surficial layer of topsoil. The topsoil thickness was approximately 50mm in BH-1, and 125mm in BH-2.

4.2.2 Silty Sand

A layer of silty sand was observed immediately beneath the topsoil in borehole BH-1, and extended to a depth of about 2.1 mbeg. The upper zone (to 0.8 mbeg) contained some organic matter. The silty sand was generally brown in colour and existed in a loose to compact, moist in-situ state. Moisture content tests conducted on samples of the silty sand yielded values ranging from approximately 14 to 30 % moisture by weight.

4.2.3 Clayey Silt

A layer of clayey silt was encountered in borehole BH-1 immediately beneath the silty sand, and extended to a depth of about 7.3 mbeg. The clayey silt was brown grading to grey at about 3.7 mbeg, and existed in a firm to very soft in-situ state of consistency. Moisture content tests conducted on samples of the clayey silt yielded values ranging from approximately 16 to 41 % moisture by weight.

4.2.4 Till

A layer of sandy silt till was encountered immediately beneath the clayey silt in BH-1, and extended to about 13.4 mbeg. The till was grey to dark grey in colour, contained sandy silt with trace clay and gravel, and existed in a compact, moist in-situ condition. Moisture content tests conducted on samples of the till yielded values ranging from approximately 9 to 12 % moisture by weight. A grain size distribution analysis conducted on a representative sample of the till suggests the following composition: 8 % gravel, 38 % sand, and 54 % silt and clay-sized particles. A hydrometer test performed on the same sample indicates it contained about 30% particles between 5 and 75 um in size.

4.2.5 Groundwater

Groundwater observations and measurements were obtained from the open borehole during and upon completion of drilling operations. Groundwater seepage was first observed at about 2.1 mbeg in BH-1. Groundwater accumulation within the open borehole BH-1 was at 1.2 mbeg upon completion of the drilling operations. It must be noted that groundwater levels are transient and tend to fluctuate with the seasons, periods of precipitation, and temperature.

4.2.6 Inferred Bedrock / Practical Refusal

Practical refusal to further test hole advancement was encountered in borehole BH-1 at a depth of 13.7 mbeg. The cause of the practical refusal was inferred as bedrock (based on the nature of the refusal), but this was not confirmed by diamond coring as part of this investigation. The borehole log provides details regarding the depth of practical refusal encountered.

The depth at which practical refusal was encountered was interpreted by GHD as being the depth of competent bedrock for the purpose of logging the test holes. It is noted that bedrock typically exhibits a certain degree of weathering and/or fracturing in its upper zone. This weathering/fracturing effect can increase significantly in shale and limestone bedrock. Due to the penetrative nature of advancing test holes with drilling equipment, the borehole may have penetrated partly into the bedrock, (i.e., through this upper zone of more fractured / weathered bedrock) before encountering refusal. A layer of inferred fractured bedrock is illustrated on the BH-1 from 13.4 mbeg to the depth of refusal at 13.7 mbeg.

4.3 Borehole BH-2 (Proposed FR)

4.3.1 Topsoil

Both boreholes encountered a surficial layer of topsoil. The topsoil thickness was approximately 50mm in BH-1, and 125mm in BH-2.

4.3.2 Fill

A layer of fill material was encountered immediately beneath the topsoil in BH-2, and extended to a depth of 9.1 mbeg. The fill was a range of mixed soils, including sand and silt with organics. It was generally in a loose to very loose in-situ state of relative density. Moisture content tests performed on samples of the fill yielded values ranging from 18 to 57 % moisture by weight.

4.3.3 Peat

A layer of peat was encountered immediately beneath the fill in borehole BH-2, and extended to a depth of about 11.4 mbeg. This material was highly organic, and in a loose to compact in-situ state of relative density. Moisture content tests performed on samples of the peat yielded values ranging from 60 to 657 % moisture by weight.

4.3.4 Silty Sand

A layer of silty sand was encountered immediately beneath the peat in BH-2, and extended to the full depth of investigation (12.2 mbeg). The silty sand was dark grey in colour, contained silty sand with gravel and trace clay, and existed in a compact, wet in-situ condition. A moisture content test conducted on a sample of the silty sand yielded a value of approximately 15 % moisture by weight.

4.3.5 Groundwater

Groundwater observations and measurements were obtained from the open borehole during and upon completion of drilling operations. Groundwater seepage was first observed at about 1.5 mbeg in BH-2. Groundwater accumulation within the open borehole BH-2 was at 1.8 mbeg upon completion of the drilling operations. It must be noted that groundwater levels are transient and tend to fluctuate with the seasons, periods of precipitation, and temperature.

5. Discussion and Recommendations

5.1 General

The purpose of this geotechnical investigation was to determine the subsurface soil and groundwater conditions at the proposed tower structure locations and to provide geotechnical design and construction recommendations for their foundation systems.

Based on our understanding of the project, discussed in Section 1, and the subsurface soil and groundwater conditions at the borehole locations, the following geotechnical design and construction recommendations are provided for the proposed structures. The geotechnical design and construction recommendations in the following sections are provided for the guidance of the design engineer, and based on the subsurface conditions encountered at the borehole locations for BH-1 and BH-2 only. Contractors bidding on or undertaking the works should decide on their own investigation, and their own interpretation of the factual borehole result, so that they may draw their own conclusions how the sub-surface conditions may affect them.

5.2 Excavations and Groundwater Control

5.2.1 Excavations

Excavations for the pile cap/foundation slab for the proposed towers are expected to be shallow in the order of 1 to 1.5 m deep, and as such will be limited to the existing silty sand or fill deposits. Excavations must be carried out in accordance with the Occupational Health and Safety Act and Regulations for Construction Projects. These regulations designate four broad classifications of soils to stipulate appropriate measures for excavation safety. The undisturbed cohesive and cohesionless soil deposits found at the sites are considered generally as a Type 4 soil.

Where workmen must enter a trench or excavation carried deeper than 1.2 m, the trench or excavation must be suitably sloped and/or braced in accordance with the regulation requirements. The regulation stipulates maximum slopes of excavation by soil type as follows:

Maximum Slope Inclinations for Construction Excavations

Soil Type	Base of Slope	Maximum Slope Inclination
1	Within 1.2 metres of bottom of trench	1 horizontal to 1 vertical
2	Within 1.2 metres of bottom of trench	1 horizontal to 1 vertical
3	From bottom of trench	1 horizontal to 1 vertical
4	From bottom of trench	3 horizontal to 1 vertical

The soils encountered at the borehole locations can be classified as Type 4 soils when not affected by the groundwater seepage, in accordance with the OHSA regulations. Section 226 of the OHSA Regulations specifies maximum slope inclination of 3 horizontal to 1 vertical (3H:1V) for a Type 4 soil to the bottom of an excavation.

Minimum support system requirements for steeper excavations are stipulated in Sections 235 through 238 and 241 of the Act and Regulations and include provisions for timbering, shoring and moveable trench boxes.

5.2.2 Dewatering

Based on the borehole investigation, significant groundwater infiltration is not expected in the shallow excavations anticipated for underground utility construction. Groundwater seepage, if encountered, should be controlled by conventional sump pump methods provided with a filter liner in order to prevent migration of fines. Surface water should be directed away from open excavations. Spoil piles should be kept a minimum of 1 m away from the top of any excavation to prevent excess loading on excavation sidewalls.

5.3 Backfilling

Backfilling of excavations can be accomplished by reusing the excavated soils or similar fill material provided the moisture content is maintained within 2 % of optimum. Backfill materials used for site grading or backfilling should be placed in thin lifts not exceeding 200 mm and thoroughly compacted using a sheeps foot roller to a minimum of 95 percent SPMDD. Care will be required to separate these materials from the site stockpiles. Cobbles and boulders in excess of 150 mm diameter should be excluded from the soils used as backfill material.

All excavations must be widened sufficiently to accommodate the appropriate compaction equipment. Provided the trenches are backfilled with materials similar to the adjacent subgrade soils then frost tapers will not be required.

Backfilling operations should be carried out with the following minimum requirements:

-) adequate heavy vibratory compaction equipment is used to compact the material;
-) loose lift thickness should not exceed 200 mm;
-) the soils be at suitable moisture contents to achieve compaction to at least 95 % SPMDD or in settlement sensitive areas to at least 98 % SPMDD; and
-) general backfill materials to consist of earth fill comprised of inorganic soils, with no particle sizes greater than 150 mm, and containing no topsoil, organics, or other deleterious materials.

5.4 Foundation Recommendations

Due to variable, loose and soft to very soft, compressible, and generally unsuitable soil conditions extending to a depth of 7.3 mbeg (BH-1) and at least 11.4 mbeg (BH-2), a shallow conventional foundation system is not considered suitable for support of the proposed tower structures at either location. It is therefore recommended that the tower structures be supported on deep (pile) foundations. As already discussed the soft to very soft clayey silt (BH-1), and fill over peat (BH-2) are not considered suitable for support of any foundation system. It is recommended that the piles be supported on the bedrock.

It is noted that confirmation of depth to bedrock was not part of the scope of work specified by the Client. GHD terminated BH-1 at 13.7 mbeg due to split spoon and auger refusal, which is indicative of the bedrock. BH-2 was terminated at 12.2 mbeg before encountering dense soil or practical refusal due to time constraints. *It is therefore recommended that prior to finalizing any design or construction parameters for the Proposed FR Tower (at BH-2), deeper exploration be performed to assess the depth to practical refusal (inferred bedrock).*

Different types of piles such as steel driven piles, cast-in-place concrete piles or even helical piles can be considered depending upon the availability of specialist piling contractor for a particular piling system. All the discussed pile systems have their relative merits and demerits, for example, cost of mobilizing a pile-driving crane could be high. Due to the shallow groundwater conditions construction of cast in place augered piles may pose some difficulty. The proprietary helical (screw) piles are typically suitable for only relatively light loads.

Regardless of the deep foundation system selected, it is recommended that the construction tender request a per-unit rate for installation of the deep foundation system, to allow for any variations in the bedrock depth and corresponding depth of installation of each foundation element.

Design and construction recommendations for each of these three pile systems are provided in the following sections.

5.4.1 Driven Steel Pile Foundation

Steel pipe and H-sections are commercially available in various sizes, and can be used in pile foundations. The steel piles should be fitted with rock tips, and driven to refusal into the intact probable bedrock. A steel pile driven to refusal on bedrock can be designed for a Serviceability Limit State (SLS) and Ultimate Limit State Design (ULS) resistances 6,000 kPa. The ultimate capacity of a driven pile will be a function of the allowable stresses that can be resisted by its material with negligible settlement, as such same SLS and ULS capacities have been provided.

A pile must be isolated to a depth of 1.8 m from adjacent strata to prevent adfreeze induced uplift forces (see discussion in Section 5.3.4).

5.4.2 Cast-in-Place Concrete Pile Foundation

Cast-in-Place concrete piles socketed into probable bedrock can also be considered. For the installation of cast-in-place drilled piles/caissons, use of a temporary steel liner will be required in order to prevent caving in and neck formation of the drilled hole in the underlying very loose or very soft soils, and to cut off groundwater seepage.

If the use of a temporary steel liner is considered non-feasible, auger cast piles can be used. Auger cast piles are constructed by augering to the required bearing depth, using a continuous flight hollow stem auger in a continuous downward movement. Soil travels upward as the auger rotates, keeping the flights full of soil cuttings. Once the required depth is achieved, concrete is pumped under pressure through the interior of the hollow stem auger to the pile tip. The auger is slowly withdrawn and concrete is continuously pumped, ensuring there is no open, unsupported hole at any location in the vertical profile. Perched water, if encountered, could flow down the auger, however, the upward movement of soil at all times and the advance of the rising concrete minimizes water infiltration. A concrete head of at least 1 m should be maintained inside the hollow stems (auger-cast piles) or steel liner (drilled piles), at the time of concreting, in order to avoid voids and neck formation.

The cast-in-place concrete pile supported in an at least 0.5 m deep bedrock socket can be designed for an axial compression of 1,200 kPa for SLS and ULS design resistances. The ultimate capacity of a cast-in-place pile will be a function of the allowable stresses that can be resisted by its material with negligible settlement, as such same SLS and ULS capacities have been provided.

All piles must be installed under geotechnical supervision to ensure that the piles are constructed in accordance with the above recommendations.

5.4.3 Helical Pile

Given the presence of loose and very soft deposits at the sites, the use of helical piles (screw piles) designed and installed by a specialist turnkey contractor may be a suitable option for the relatively lightly loaded towers. The installation technique for helical piers is vibration free and does not require any dewatering.

The allowable axial (compression and uplift), and lateral capacity should be confirmed in writing by the installer. For preliminary design purposes a single helical pier with a series of 250 mm, 300 mm and 350 mm helix combination can be designed for a typical allowable axial pile capacity of 300 kN, when supported on the bedrock. The helical pile(s) should be torqued to the required capacity.

The helical piles should be installed in the presence of the geotechnical engineer to confirm that the appropriate torque has been achieved.

In order to provide for increased lateral stability, we recommend that the helical pile shaft be installed inside a PVC casing (minimum 150 mm diameter) and the interior of the casing grouted on completion.

5.4.4 Adfreeze Forces

Based on the Canadian Foundation Manual (4th Edition) uplift forces due to clayey soils freezing against concrete can exceed 60 kPa. It is therefore recommended that the top 1.8 m of the cast-in-place pile should be isolated from the surrounding soils by using a sonotube wrapped with poly material stapled at seams or other suitable means.

Pile caps should be totally supported on the pile and must not be in contact with the ground surface so that it is not subjected to uplift pressures due to frost-induced ground heave.

5.4.5 Lateral Pile Capacity

The lateral capacity of a single pile can be estimated using the horizontal modulus of subgrade reaction 'k' values provided in the following table:

Stratigraphic Unit	Modulus of Subgrade Reaction kPa/m
Very soft to soft Clay soils	5,000
Very loose Sand and Gravel	10,000
Very dense Sand and Gravel	50,000
Probable Bedrock	100,000

5.4.6 General Pile Recommendations

The actual pile capacities can vary over a large range due to many factors including but not limited to actual bearing stratum and construction practices used. The design parameters provided in this report should therefore be considered preliminary. It is recommended that a specialist piling-contractor should review the borehole logs and verify piling suitability and capacity based on piling experience under similar conditions.

The actual design pile capacities should be confirmed by dynamic pile analysis and testing carried out in accordance with ASTM D4945 for driven piles. For the cast in place concrete piles and helical piles static load tests (ASTM D 1143) should be carried out. It is recommended that 100 percent of the cast in place piles be tested for structural integrity using low strain methods (ASTM D 5882).

The group efficiency factor for the axial pile capacities can be taken as 1 for a pile group bearing into bedrock.

The piles must be installed under geotechnical supervision to ensure that the piles are constructed in accordance with the above recommendations.

5.5 Seismic Site Class

The 2006 Ontario Building Code (2006 OBC) requires the assignment of a Seismic Site Class for calculations of earthquake design forces and the structural design based on a two percent probability of exceedance in 50 years. According to the 2006 OBC, the Seismic Site Class is a function of soil profile, and is based on the average properties of the subsoil strata to a depth of 30 m below the ground surface. The 2006 OBC provides the following three methods to obtain the average properties for the top 30 m of the subsoil strata:

-) Average shear wave velocity;
-) Average Standard Penetration Test (SPT) values (uncorrected for overburden); or
-) Average undrained shear strength.

Based on the results of the recent geotechnical investigation, the boreholes extended to a maximum depth of 13.7 mbeg only, where practical refusal was encountered indicating likely bedrock, but remains unconfirmed as part of this investigation. The subsurface profile below 13.7 mbeg is therefore not known. For a preliminary design purposes, based on the criteria listed in Table 4.1.8.4.A. of the 2006 OBC and our knowledge of the regional geology, a Seismic Site Class 'E' is recommended for design purposes.

5.6 Corrosion Potential

Analytical testing was carried out on two (2) soil samples to assess corrosion potential of the subsurface soils. The samples tested were as follows:

-) BH-1 SS-4 (2.3 to 2.7 mbeg); and
-) BH-2 SS-5 (3.0 to 3.5 mbeg).

The soil samples were tested for pH, resistivity, chlorides, sulphides, sulphate, and redox potential. The test results are summarized in the following table. The detailed laboratory analytical report is provided in Appendix C.

Sample ID	BH-1	BH-2
	SS-4	SS-5
Depth (mbeg)	2.3 to 2.7	3.0 to 3.5
pH	7.69	7.00
Redox Potential (mV)	198	-133
Resistivity (ohm-cm)	3610	5570
Sulphide (mg/g)	<0.06*	2.26
Sulphate (mg/g)	40	40
Chloride (µg/g)	149	7

*detection limits

The American Water Works Association (AWWA) publication 'Polyethylene Encasement for Ductile-Iron Pipe Systems' ANSI/AWWA C105/A21.5-10 dated October 1, 2010 assigns points based on the results of the above tests. A soil that has a total point score of 10 or more is considered to be potentially corrosive to ductile iron pipe. Based on the results obtained for the samples submitted, seven points can be assigned due to continuously wet conditions caused by the shallow groundwater table and a negative redox potential (BH-2 sample). The results, however, indicate non corrosive conditions, therefore the site soils, represented by the analyzed samples, are not considered to be potentially corrosive.

Table 3 of the Canadian Standards Association (CSA) document A23.1-04/A23.2-04 'Concrete Materials and Methods of Concrete Construction/Methods of Test and Standard Practices for Concrete' divides the degree of exposure into the following three classes:

Degree (Class) of Exposure	Water Soluble (SO ₄) in Soil Sample (%)
Very Severe (S-1)	> 2.0
Severe (S-2)	0.20 – 2.0
Moderate (S-3)	0.10 – 0.20

A review of the analytical test results shows the sulfate content in the tested samples was found to be approximately 0.04 percent, which indicates the degree of exposure of the subsurface concrete structures to sulphate attack is low. Therefore normal Portland cement can be used for the below grade concrete structures.

5.7 General Recommendations

5.7.1 Further Exploration

Prior to finalizing any design or construction parameters upon which the bedrock depth is based, it is strongly recommended that further (deeper) exploration be performed at BH-2 (the Proposed FR location) to obtain the depth to refusal and as such assess the likely depth to bedrock at that location.

5.7.2 Subsoil Sensitivity

The native subsoils are susceptible to strength loss or deformation if saturated or disturbed by construction traffic. Therefore, where the subgrade consists of approved soil, care must be taken to protect the exposed subgrade from excess moisture and from construction traffic.

5.7.3 Winter Construction

The subsoil encountered across the site are frost-susceptible and freezing conditions could cause problems to the structure. As preventive measures, it is recommended that during winter construction, exposed surfaces intended to support the structural loads must be protected against freezing by means of loose straw and tarpaulins, heating, etc.

5.7.4 Design Review and Construction Inspections

GHD should be contacted to review and comment on the foundation and grading design details to confirm that the geotechnical requirements stated in this report are addressed.

Geotechnical inspections are required during construction operations for quality control and assurance (QA/QC) purposes. Inspection and testing services include verification of subgrade soil conditions below bases, slabs and footings, monitoring of fill placement, and general testing of geotechnical materials including fill and concrete.

6. Statement of Limitations

The attached Statement of Limitations is an integral part of this report. Should questions arise regarding any aspect of this report, please contact our office.

Sincerely,

GHD



Vincent Zappia, C.E.T.

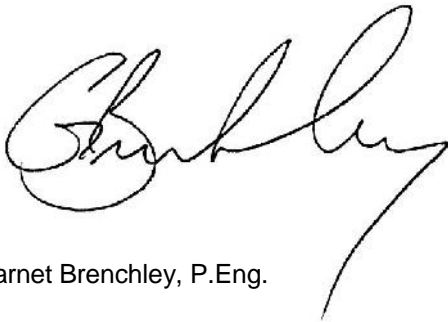

Garnet Brenchley, P.Eng.



STATEMENT OF LIMITATIONS

This report is intended solely for the Canadian Coast Guard / Fisheries and Oceans Canada and other parties explicitly identified in the report and is prohibited for use by others without GHD's prior written consent. This report is considered GHD's professional work product and shall remain the sole property of GHD. Any unauthorized reuse, redistribution of or reliance on the report shall be at the Client and recipient's sole risk, without liability to GHD. Client shall defend, indemnify and hold GHD harmless from any liability arising from or related to Client's unauthorized distribution of the report. No portion of this report may be used as a separate entity; it is to be read in its entirety and shall include all supporting drawings and appendices.

The recommendations made in this report are in accordance with our present understanding of the project, the current site use, ground surface elevations and conditions, and are based on the work scope approved by the Client and described in the report. The services were performed in a manner consistent with that level of care and skill ordinarily exercised by members of geotechnical engineering professions currently practicing under similar conditions in the same locality. No other representations, and no warranties or representations of any kind, either expressed or implied, are made. Any use which a third party makes of this report, or any reliance on or decisions to be made based on it, are the responsibility of such third parties.

All details of design and construction are rarely known at the time of completion of a geotechnical study. The recommendations and comments made in the study report are based on our subsurface investigation and resulting understanding of the project, as defined at the time of the study. We should be retained to review our recommendations when the drawings and specifications are complete. Without this review, GHD will not be liable for any misunderstanding of our recommendations or their application and adaptation into the final design.

By issuing this report, GHD is the geotechnical engineer of record. It is recommended that GHD be retained during construction of all foundations and during earthwork operations to confirm the conditions of the subsoil are actually similar to those observed during our study. The intent of this requirement is to verify that conditions encountered during construction are consistent with the findings in the report and that inherent knowledge developed as part of our study is correctly carried forward to the construction phases.

It is important to emphasize that a soil investigation is, in fact, a random sampling of a site and the comments included in this report are based on the results obtained at the two (2) test hole locations only. The subsurface conditions confirmed at the 2 test hole locations may vary at other locations. The subsurface conditions can also be significantly modified by construction activities on site (eg. excavation, dewatering and drainage, blasting, pile driving, etc.). These conditions can also be modified by exposure of soils or bedrock to humidity, dry periods or frost. Soil and groundwater conditions between and beyond the test locations may differ both horizontally and vertically from those encountered at the test locations and conditions may become apparent during construction which could not be detected or anticipated at the time of our investigation. Should any conditions at the site be encountered which differ from those found at the test locations, we request that we be notified immediately in order to permit a reassessment of our recommendations. If changed conditions are identified during construction, no matter how minor, the recommendations in this report shall be considered invalid until sufficient review and written assessment of said conditions by GHD is completed.

Enclosures



TEST HOLE LOCATION PLAN

*Geotechnical Investigation
Oshawa Harbour Range Towers
Oshawa, Ontario*

DATE: February, 2015

SCALE: ND

REF. NO.: 11114483-01

PLAN NO.: FIGURE 1



DRAWN BY: PB

CHECKED BY: VZ

Appendix A

Borehole Logs



BOREHOLE No.: BH-1
ELEVATION: Existing Grade

BOREHOLE REPORT

Page: 1 of 1

CLIENT: Department of Fisheries and Oceans Canada

PROJECT: Geotechnical Investigation - Oshawa Harbour Range Towers

LOGGED BY: P. Bodjona DATE: 8 March 2016

DRILLING COMPANY: Strong Soil Search METHOD: Solid Stem Augers and Split Spoons

NOTES:

LEGEND

- ☒ SS - SPLIT SPOON
- ▨ AS - AUGER SAMPLE
- ▧ ST - SHELBY TUBE
- ▩ CS - CORE SAMPLE
- ▼ - WATER LEVEL

UTM: 17T 674405E 4860089N

BOREHOLE LOG GEOTECH 11114483-01, 16-03-08, OSHAWA HARBOUR, BOREHOLE LOGS.GPJ, GEOLOGIC.GDT, 31/3/16

Depth	m Below Existing Grade	Stratigraphy	DESCRIPTION OF SOIL AND BEDROCK	Type and Number	Recovery	Moisture Content	Blows per 6 in. / 15 cm	Penetration Index	Shear test (Cu) Sensitivity (S) Water content (%) Atterberg limits (%)										COMMENTS
									10	20	30	40	50	60	70	80	90		
	0.0		GROUND SURFACE		%	%		N	10	20	30	40	50	60	70	80	90		
1	0.1		TOPSOIL (50 mm)	SS-1	67	14	3	14											
2	0.8		SILTY SAND- Brown Silty Sand, With ORGANICS, Moist, Compact	SS-2	56	20	2	5	×	○									
3	1.0		Brown Silty Sand, Trace Clay, Moist, Loose	SS-3	89	30	2	2										▼ WL - 1.2 m 3/8/2016	
4	2.1		CLAYEY SILT- Brown Clayey Silt, Moist, Firm	SS-4	100	30	3	9	×	○									
5	2.1			SS-5	83	33	3	3										Groundwater seepage first encountered at 2.1 m	
6	3.0			SS-6	89	41	2	2	×	○									
7	3.7		Grey Clayey Silt / Silty Clay, Wet, Very Soft	SS-7	100	16	2	2											
8	3.7			SS-8	100	12	2	2											
9	5.0		TILL - Grey Sandy Silt, Trace Clay, Trace Gravel, Wet, Compact	SS-9	83	9	1	2	×	○									
10	5.0			SS-10	89	11	1	1											
11	6.0			SS-11	50	10	0	0	×	○									
12	6.0			SS-12	100	15	0	0											
13	7.3			SS-13	83	9	0	0											
14	7.3			SS-14	89	11	3	7											
15	8.0			SS-15	50	10	8	15	×	○									
16	8.0			SS-16	89	11	3	8											
17	9.0			SS-17	50	10	12	23	○	×									
18	9.0			SS-18	89	11	10	13											
19	10.0			SS-19	50	10	8	25	○	×									
20	10.4		Dark Grey Silty Sand, With Gravel, Trace Clay, Moist, Compact	SS-20	89	11	12	25											
21	10.4			SS-21	50	10	13	24	○	×									
22	10.4			SS-22	89	11	12	25											
23	11.0			SS-23	50	10	13	24	○	×									
24	11.0			SS-24	89	11	12	25											
25	12.0			SS-25	50	10	13	24	○	×									
26	12.0			SS-26	89	11	12	25											
27	13.0			SS-27	50	10	11	24	○	×									
28	13.0			SS-28	89	11	12	25											
29	13.4		BEDROCK- (Inferred) Grey Weathered Shale	SS-29	100	15	50=1	100+	○										
30	13.7		END OF BOREHOLE	SS-30	100	15	50=1	100+											
31	14.0			SS-31	100	15	50=1	100+											
32	14.0			SS-32	100	15	50=1	100+											
33	15.0			SS-33	100	15	50=1	100+											

SS-3:
 8% Gravel
 38% Sand
 54% Silt and Clay
 30% between
 5-75 µm
 Borehole Caved
 to 12.2 m
 Refusal to further
 advancement of
 the augers.
 Bedrock Inferred

Appendix B

Physical Laboratory Data



Particle-Size Analysis of Soils (Geotechnical)
(USCS) (ASTM D422)

Client: Department of Fisheries and Oceans Canada Lab no.: SS-D-16-11

Project/Site: Oshawa Harbour Range Towers Project no.: 11114483-01

Borehole no.: BH 1 Sample no.: SS 10

Depth: 10.7 - 11.1 m Enclosure: B-1

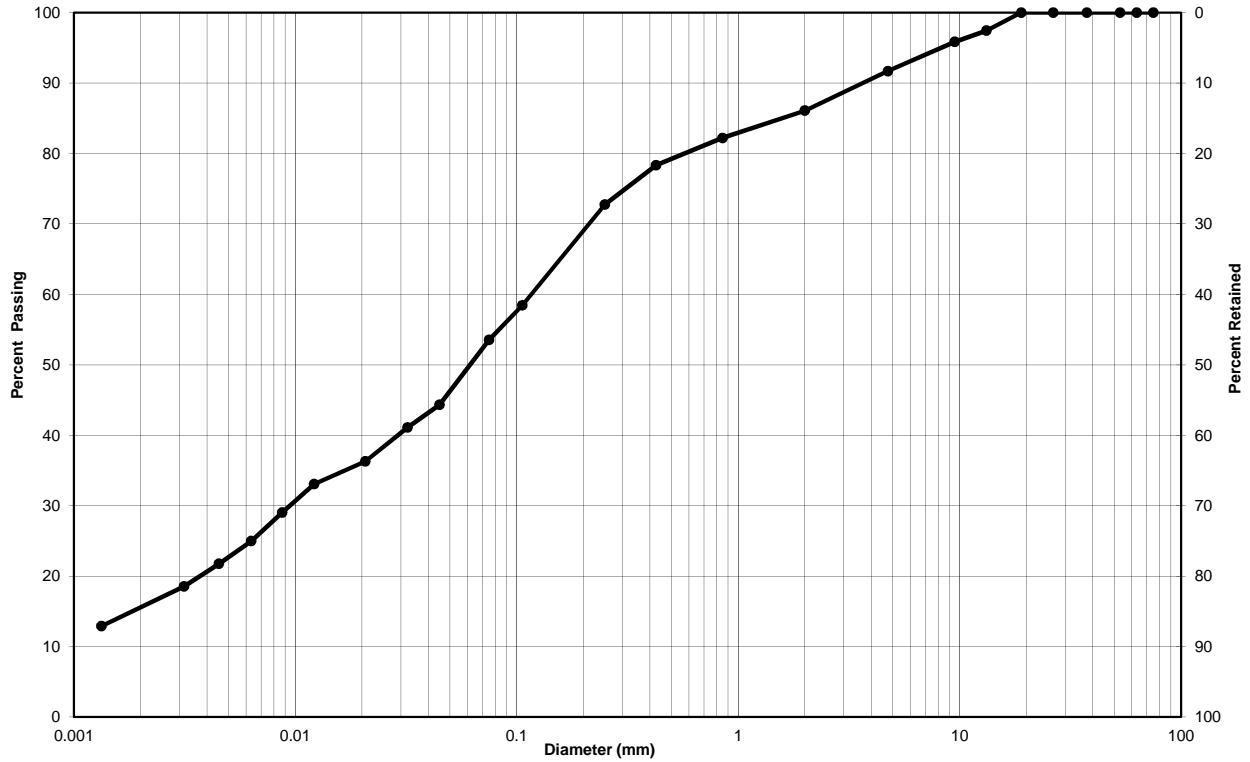

Clay & Silt	Sand			Gravel	
	Fine	Medium	Coarse	Fine	Coarse
Unified Soil Classification System					

Soil Description	Gravel	Sand	Clay & Silt
BH 1, SS 10	8	38	54

Remarks:

Performed by: [Signature] Date: March 16, 2016

Verified by: [Signature] Date: March 16, 2016



Particle-Size Analysis of Soils (Geotechnical)
(USCS) (ASTM D422)

Client:	Department of Fisheries and Oceans Canada	Lab no.:	SS-D-16-14
Project/Site:	Oshawa Harbour Range Towers	Project no.:	11114483-01

Borehole no.:	BH 2	Sample no.:	SS 12
Depth:	8.3 - 9.1 m	Enclosure:	B-2

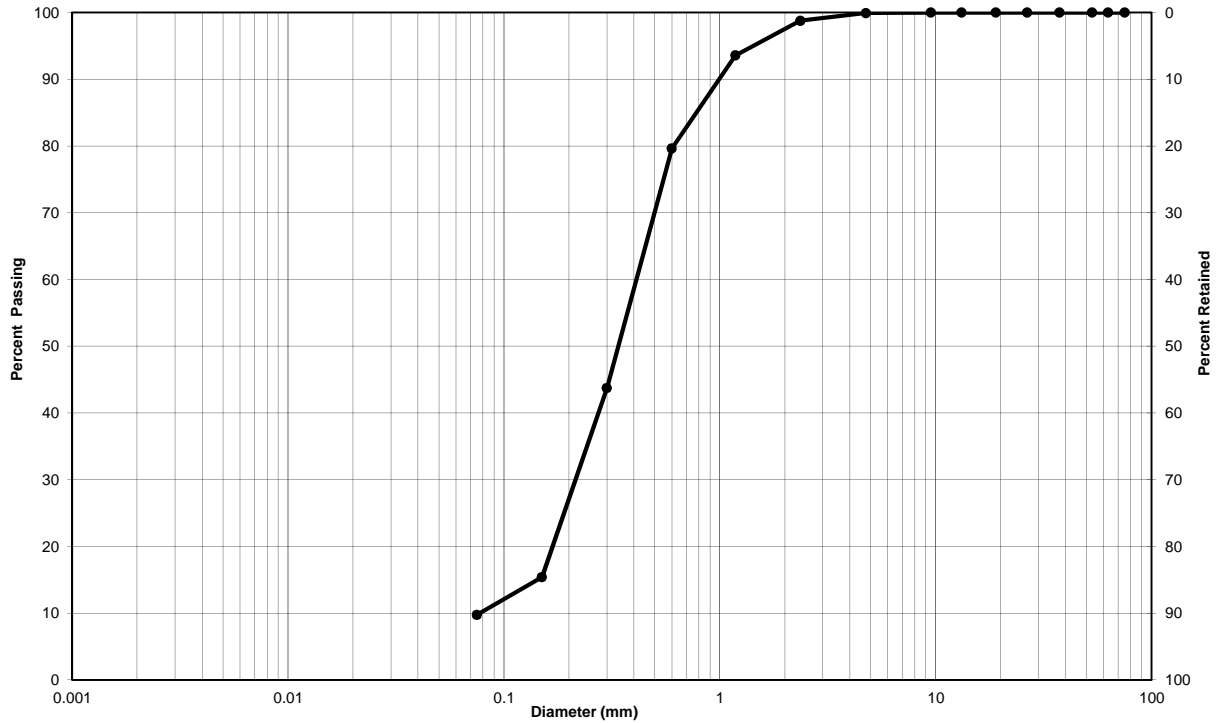

Clay & Silt	Sand			Gravel	
	Fine	Medium	Coarse	Fine	Coarse
Unified Soil Classification System					

Soil Description	Gravel	Sand	Clay & Silt
BH 2, SS 12	0	90	10

Remarks: _____

Performed by:		Date:	April 4, 2016
Verified by:		Date:	April 4, 2016

Appendix C

Chemical Laboratory Data

C.O.C.: G50439

REPORT No. B16-05897

Report To:

GHD Limited
 651 Colby Drive,
 Waterloo Ontario N2V 1C2 Canada

Attention: Pidenam Bodjona

Caduceon Environmental Laboratories

110 West Beaver Creek Rd Unit 14

Richmond Hill ON L4B 1J9

Tel: 289-475-5442

Fax: 289-562-1963

DATE RECEIVED: 10-Mar-16

JOB/PROJECT NO.: Oshawa Harbour/11114483-01

DATE REPORTED: 16-Mar-16

P.O. NUMBER:

SAMPLE MATRIX: Soil

WATERWORKS NO.

Client I.D.	BH-1, SS-4		
Sample I.D.	B16-05897-1		
Date Collected	08-Mar-16		

Parameter	Units	R.L.	Reference Method	Date/Site Analyzed			
pH @25°C	pH Units		MOEE 3137	11-Mar-16/R	7.69		
Resistivity	ohms·cm	1	MOEE3138	11-Mar-16/R	3610		
REDOX potential	mV		In-House	11-Mar-16/R	198		
Chloride	µg/g	5	SM4110C	14-Mar-16/O	149		
Sulphate	µg/g	10	SM4110C	14-Mar-16/O	40		
Sulfide	µg/g	0.06	In-House	16-Mar-16	< 0.06	¹	

¹ subcontracted to Testmark Labs.



Christine Burke
 Lab Supervisor

R.L. = Reporting Limit

Test methods may be modified from specified reference method unless indicated by an *

Site Analyzed=K-Kingston,W-Windsor,O-Ottawa,R-Richmond Hill

The analytical results reported herein refer to the samples as received. Reproduction of this analytical report in full or in part is prohibited without prior consent from Caduceon Environmental Laboratories.

C.O.C.: G50473

REPORT No. B16-07662

Report To:

GHD Limited
 651 Colby Drive,
 Waterloo Ontario N2V 1C2 Canada

Attention: Vincent Zappia

Caduceon Environmental Laboratories

110 West Beaver Creek Rd Unit 14
 Richmond Hill ON L4B 1J9
 Tel: 289-475-5442
 Fax: 289-562-1963

DATE RECEIVED: 30-Mar-16
 DATE REPORTED: 04-Apr-16
 SAMPLE MATRIX: Soil

JOB/PROJECT NO.: Oshawa Harbour/11114483-01
 P.O. NUMBER:
 WATERWORKS NO.

Client I.D.	BH-2, SS-5		
Sample I.D.	B16-07662-1		
Date Collected	28-Mar-16		

Parameter	Units	R.L.	Reference Method	Date/Site Analyzed			
pH @25°C	pH Units		MOEE 3137	31-Mar-16/R	7.00		
Resistivity	ohms·cm	1	MOEE3138	31-Mar-16/R	5570		
REDOX potential	mV		In-House	31-Mar-16/R	-133		
Chloride	µg/g	5	SM4110C	01-Apr-16/O	7		
Sulphate	µg/g	10	SM4110C	01-Apr-16/O	40		
Sulfide	µg/g	0.2	In-House	01-Apr-16	2.26	¹	

¹ Subcontracted to Testmark Labs



Christine Burke
 Lab Manager

R.L. = Reporting Limit
 Test methods may be modified from specified reference method unless indicated by an *
 Site Analyzed=K-Kingston,W-Windsor,O-Ottawa,R-Richmond Hill

The analytical results reported herein refer to the samples as received. Reproduction of this analytical report in full or in part is prohibited without prior consent from Caduceon Environmental Laboratories.