

PANEL NAME	PANEL DWG	QUANTITY	WIDTH	HEIGHT	PANEL THICKNESS	STRUCTURE DWG	FOOTING DWG	QUANTITY
<i>NOM DES PANNEAUX</i>	<i>DESSINS DES PANNEAUX</i>	<i>QUANTITÉ</i>	<i>LARGEUR</i>	<i>HAUTEUR</i>	<i>ÉPAISSEUR DU PANNEAU</i>	<i>DESSIN DE STRUCTURE</i>	<i>DESSIN D'ANCRAGE</i>	<i>QUANTITÉ</i>
OL-1	SA-PL-A-01	1	72" (PO)	20" (PO)	0.25" (PO)	SA-GA	SA-FT-ASSY	2
OL-2	SA-PL-A-01	1	72" (PO)	20" (PO)	0.25" (PO)	SA-GA	SA-FT-ASSY	2
OL-3	SA-PL-A-01	1	72" (PO)	20" (PO)	0.25" (PO)	SA-GA	SA-FT-ASSY	2
OL-4	SA-PL-A-01	1	72" (PO)	20" (PO)	0.25" (PO)	SA-GA	SA-FT-ASSY	2
OL-5	SA-PL-A-01	1	72" (PO)	20" (PO)	0.25" (PO)	SA-GA	SA-FT-ASSY	2
OL-6	SA-PL-A-01	1	72" (PO)	20" (PO)	0.25" (PO)	SA-GA	SA-FT-ASSY	2
OCC-1-1	WB-PL-A-01	1	55.5" (PO)	20" (PO)	0.25" (PO)	WB-GA	N/A / S.O.	N/A / S.O.
OCC-1-2	WB-PL-A-02	1	77" (PO)	20" (PO)	0.25" (PO)	WB-GA	N/A / S.O.	N/A / S.O.
OCC-1-3	WB-PL-A-03	1	40" (PO)	20" (PO)	0.25" (PO)	WB-GA	N/A / S.O.	N/A / S.O.
OCC-1-4	WB-PL-A-04	1	92" (PO)	20" (PO)	0.25" (PO)	WB-GA	N/A / S.O.	N/A / S.O.
OCC-1-5	WB-PL-A-05	1	68" (PO)	20" (PO)	0.25" (PO)	WB-GA	N/A / S.O.	N/A / S.O.
OCC-1-6	WB-PL-A-06	1	87.5" (PO)	20" (PO)	0.25" (PO)	WB-GA	N/A / S.O.	N/A / S.O.
PR-1	SA-PL-A-01	1	72" (PO)	20" (PO)	0.25" (PO)	SA-GA	SA-FT-ASSY	2
PR-2	SA-PL-A-01	1	72" (PO)	20" (PO)	0.25" (PO)	SA-GA	SA-FT-ASSY	2
PR-3	SA-PL-A-01	1	72" (PO)	20" (PO)	0.25" (PO)	SA-GA	SA-FT-ASSY	2
PR-4	SA-PL-A-01	1	72" (PO)	20" (PO)	0.25" (PO)	SA-GA	SA-FT-ASSY	2
LD-1-1	SA-PL-A-02	1	60.75" (PO)	20" (PO)	0.25" (PO)	SA-GA	SA-FT-ASSY	2
LD-1-2	SA-PL-A-03	1	52" (PO)	20" (PO)	0.25" (PO)	SA-GA	SA-FT-ASSY	2
LD-1-3	SA-PL-A-04	1	85.25"	20" (PO)	0.25" (PO)	SA-GA	SA-FT-ASSY	2
DL-1	SA-PL-A-01	1	72" (PO)	20" (PO)	0.25" (PO)	SA-GA	SA-FT-ASSY	2
DL-2	SA-PL-A-01	1	72" (PO)	20" (PO)	0.25" (PO)	SA-GA	SA-FT-ASSY	2
CEF-1	SA-PL-A-01	1	72" (PO)	20" (PO)	0.25" (PO)	SA-GA	SA-FT-ASSY	2
CEF-2	SA-PL-A-05	1	46" (PO)	20" (PO)	0.25" (PO)	SA-GA	SA-FT-ASSY	2
CEF-3	SA-PL-A-01	1	72" (PO)	20" (PO)	0.25" (PO)	SA-GA	SA-FT-ASSY	2
HW-1-1	SO-PL-A-01	1	75" (PO)	20" (PO)	0.25" (PO)	SO-GA	N/A / S.O.	N/A / S.O.
HW-1-2	SO-PL-A-02	1	34.5" (PO)	14" (PO)	0.25" (PO)	SO-GA	N/A / S.O.	N/A / S.O.
HW-1-3	SO-PL-A-03	1	88.5" (PO)	14" (PO)	0.25" (PO)	SO-GA	N/A / S.O.	N/A / S.O.
HW-2	SO-PL-A-04	1	47.25" (PO)	14" (PO)	0.25" (PO)	SO-GA	N/A / S.O.	N/A / S.O.
HW-3	SO-PL-A-04	1	47.25" (PO)	14" (PO)	0.25" (PO)	SO-GA	N/A / S.O.	N/A / S.O.
HW-4	SO-PL-A-05	1	50" (PO)	14" (PO)	0.25" (PO)	SO-GA	N/A / S.O.	N/A / S.O.
HW-5	SO-PL-A-04	1	47.25" (PO)	14" (PO)	0.25" (PO)	SO-GA	N/A / S.O.	N/A / S.O.

NOTE: PANELS AND FOOTINGS PRODUCED BY OTHERS. LISTED HERE FOR REFERENCE ONLY.

REMARQUE : LES PANNEAUX ET SURFACES SONT PRODUITS PAR DES TIERS; ILS SONT FOURNIS À TITRE DE RÉFÉRENCE UNIQUEMENT.

NOTE / NOTE :

LOCATION NAMES / NOMS DE LIEUX :

OL: OTTAWA LOCKS / ÉCLUSES D'OTTAWA

OCC: OTTAWA CONVENTION CENTER / CENTRE DES CONGRÈS D'OTTAWA

PR: PRETORIA / PRETORIA

LD: LANSDOWNE / LANSDOWNE

DL: DOW'S LAKE / LAC DOW

CEF: CENTRAL EXPERIMENTAL FARM / FERME EXPÉRIMENTALE CENTRALE

HL: HARTWELLS LOCKS / ÉCLUSE HARTWELL

FRAMING TYPES / :

SA: STAND-ALONE / AUTO-PORTANT

WB: WALL BRACKET / FIXATION MURALE

SO: STAND-OFF / MONTAGE DÉPORTÉ

RIDEAU CANAL PROMENADE: GENERAL ASSEMBLY PANEL IDENTIFICATION
 / **PROMENADE DU CANAL-RIDEAU : ASSEMBLAGE GÉNÉRAL IDENTIFICATION DU PANNEAU**



DRAWN BY / DESSIN PAR : CARRIE HURST

DATE: 05MAY17
DATE : 05MAI17

REVISIONS/RÉVISIONS :

DRAWING / DESSIN :

REVISED / RÉVISÉ PAR :

DATE:

UNIT: INCHES [mm] UNITÉ : POUCES [mm]

SCALE/ÉCHELLE :

SHEET / FEUILLE : 1

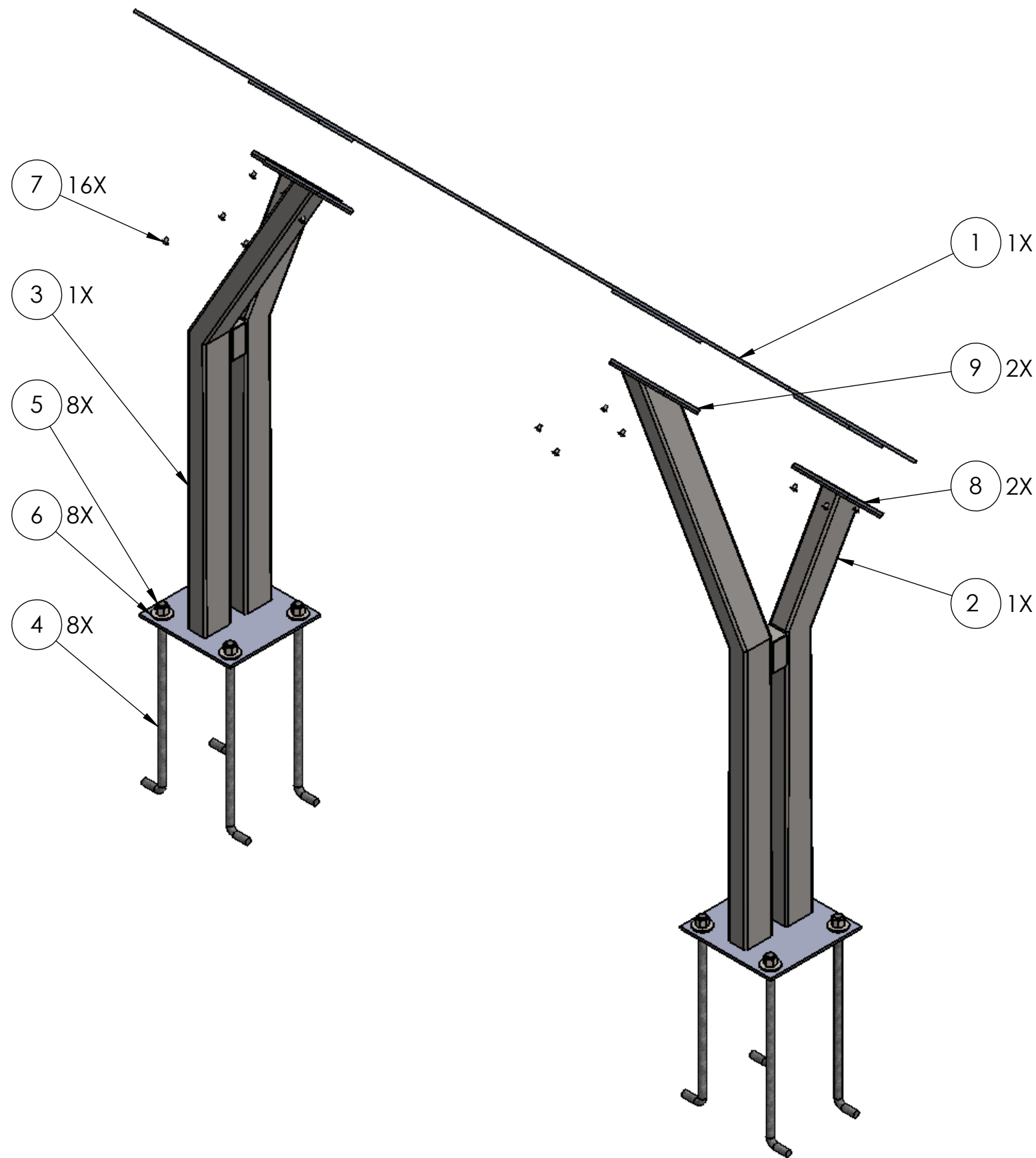

ITEM ART.	NAME NOM	DWG DESSIN	QUANTITY QUANTITÉ
1	GRAPHIC PANEL ASSY - BY OTHERS / ASS. PANNEAU GRAPHIQUE - PAR DES TIERS	SA-PL-A-#	1
2	LEFT LEG ASSY / ASS. PATTE GAUCHE	SA-LL-A-01	1
3	RIGHT LEG ASSY / ASS. PATTE DROITE	SA-RL-A-01	1
4	FOOTING - BY OTHERS / ANCRAGE - PAR DES TIERS	SA-FT-TMT-01	8
5	PLATE NUTS 5/8"-11 - BY OTHERS / ÉCROUS D'ANCRAGE 0,5PO-11	N/A / S.O.	8
6	PLATE WASHERS 5/8" - BY OTHERS / RONDELLE 5/8 PO - PAR DES TIERS	N/A / S.O.	8
7	PANEL BOLTS 1/4"-20 x 0.375" - BY OTHERS / BOULONS DE PANNEAU 0,25PO-20 x 0,375PO - PAR DES TIERS	N/A / S.O.	16
8	NYLON WASHER - 1 - BY OTHERS / RONDELLE NYLON - 1- PAR DES TIERS	SA-WA-PT-01	2
9	NYLON WASHER - 2 - BY OTHERS / RONDELLE NYLON - 2- PAR DES TIERS	SA-WA-PT-02	2

RIDEAU CANAL PROMENADE: GENERAL ASSEMBLY STAND-ALONE PANEL
/ PROMENADE DU CANAL-RIDEAU : ASSEMBLAGE GÉNÉRAL PANNEAU
AUTO-PORTANT



Canadian
Heritage

Patrimoine
canadien

Canada

DRAWN BY / DESSIN PAR : CARRIE HURST

DATE: 05MAY17
DATE : 05MAI17

REVISIONS/RÉVISIONS :

DRAWING / DESSIN :

REVISED / RÉVISÉ PAR :

DATE:

SA-GA-01

UNIT: INCHES [mm] UNITÉ : POUCES [mm]

SCALE/ÉCHELLE : 1 : 10

SHEET / FEUILLE : 2

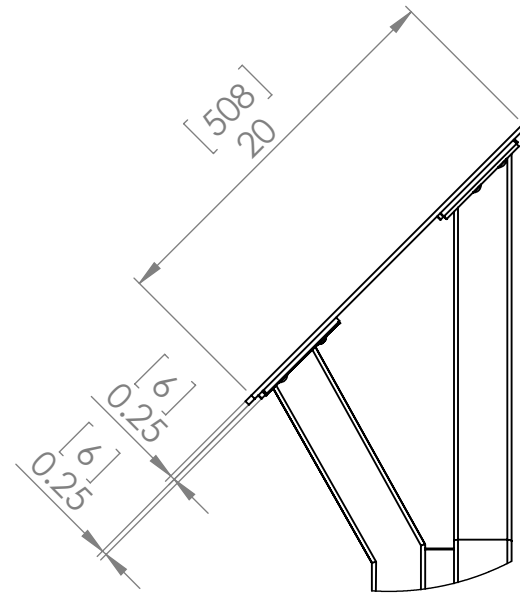
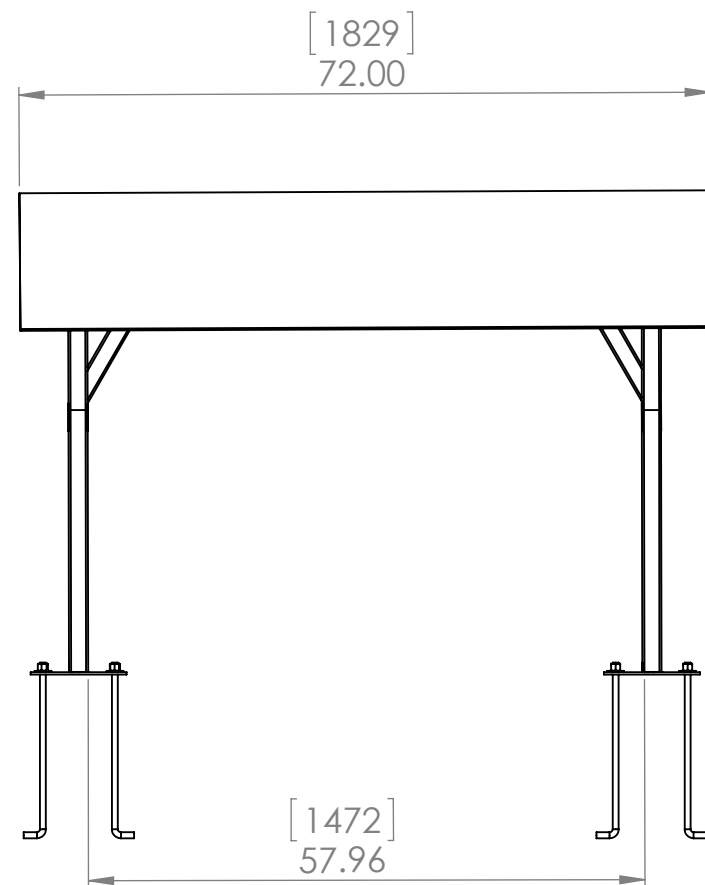
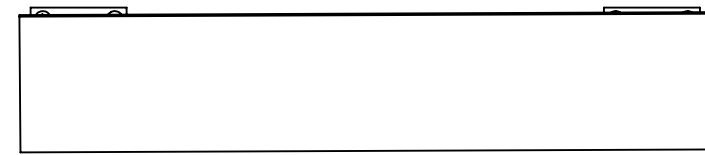

DETAIL A
SCALE 1 : 10
DÉTAIL A
ÉCHELLE 1:10

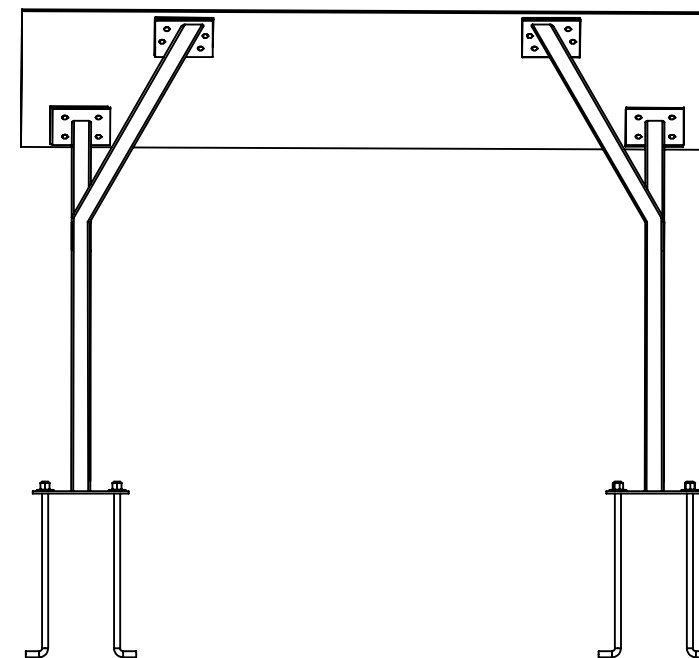
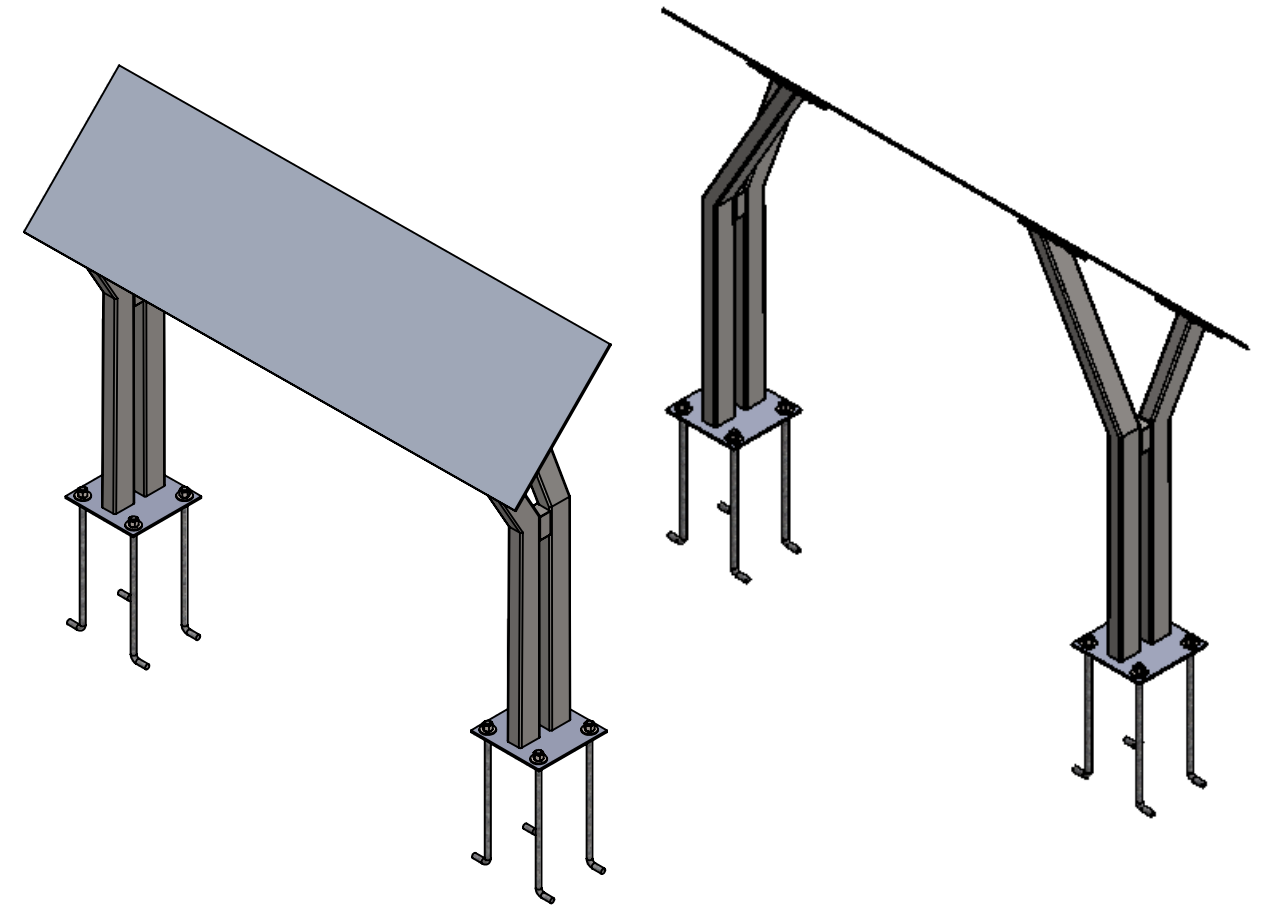
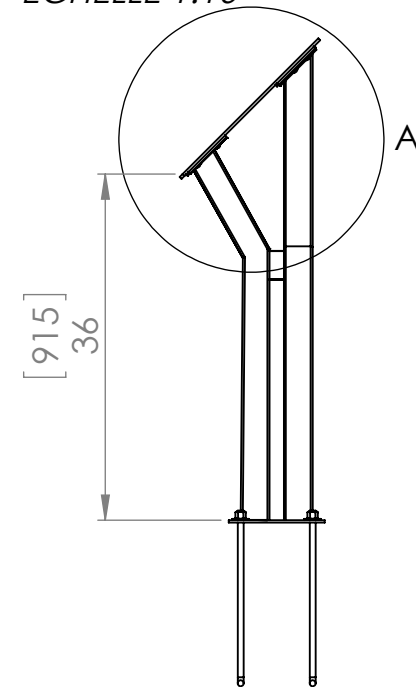

RIDEAU CANAL PROMENADE: GENERAL ASSEMBLY STAND-ALONE PANEL
/ PROMENADE DU CANAL-RIDEAU : ASSEMBLAGE GÉNÉRAL PANNEAU AUTO-PORTANT



DRAWN BY / DESSIN PAR : CARRIE HURST

DATE: 05MAY17
DATE : 05MAI17

REVISIONS / RÉVISIONS :

DRAWING / DESSIN :

REVISED / RÉVISÉ PAR :

DATE:

SA-GA-02

UNIT: INCHES [mm] UNITÉ : POUCES [mm]

SCALE/ÉCHELLE : 1 : 20

SHEET / FEUILLE : 3

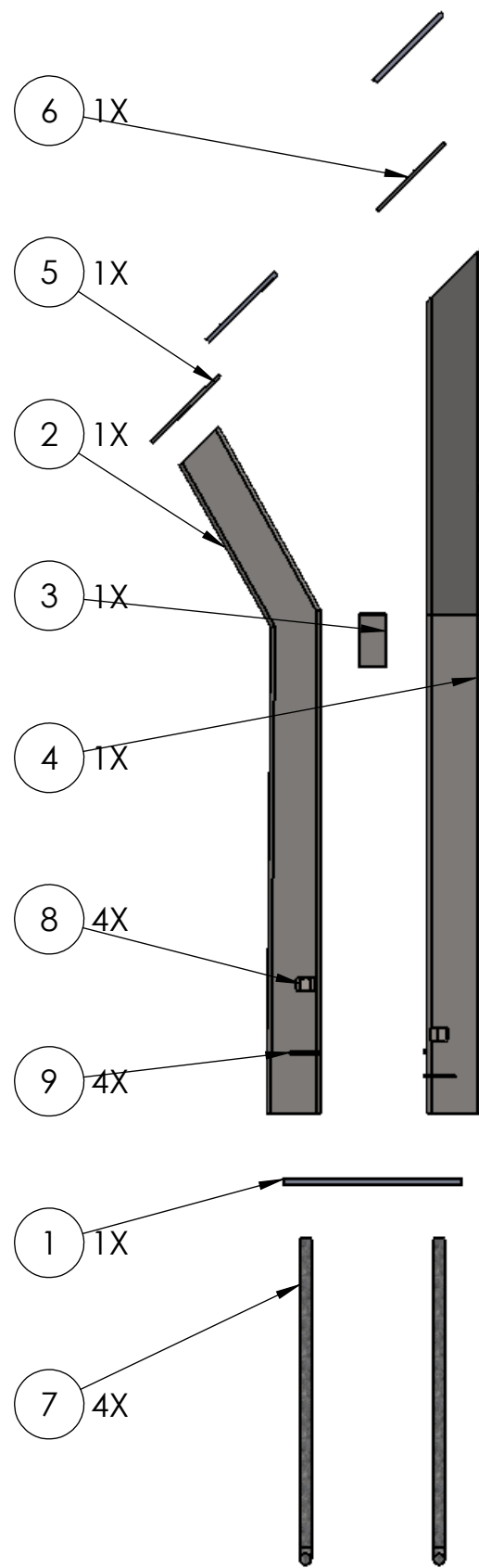

ITEM ART.	NAME NOM	DWG DESSIN	QTY QUANTITÉ
1	LEG-BASE / PATTE - BASE	L-01	1
2	LEG-FRONT / PATTE - AVANT	L-02	1
3	LEG-MID / PATTE - CENTRE	L-03	1
4	LEG-L-BACK / PATTE - G - ARRIÈRE	L-04	1
5	LEG-PANEL-PLATE-F / PATTE - PANNEAU - PLAQUE - AV.	L-06	1
6	LEG-PANEL-PLATE-R / PATTE - PANNEAU - PLAQUE - ARR.	L-07	1
7	CONCRETE FOOTING ROD:DESC: Grade 55 Hot Dipped Galvanized Length of Bend: 1" Length of Thread: 2" NOTE: RODS ARE NOT PART OF METAL FABRCIATION - THEY WILL BE SUPPLIED AND INSTALLED BY NCC LA CONTRACTOR / TIGE DE BASE DE BÉTON : DESCR. : classe 55 Galvanisé par immersion à chaud Longueur du cintrage : 1 po Longueur du filetage : 2 po REMARQUE : LES TIGES SONT EXCLUES DE LA FABRICATION DES ÉLÉMENTS EN MÉTAL - ELLES SERONT FOURNIES ET INSTALLÉES PAR UN ENTREPRENEUR DE LA CCN	N/A	4
8	5/8" GALVANIZED HEAVY NUT / ÉCROU GALVANISÉ LARGE 0, 625 PO	N/A	4
9	5/8" STAINLESS STEEL WASHER / RONDELLE EN ACIER INOXYDABLE 0,625 PO	N/A	4

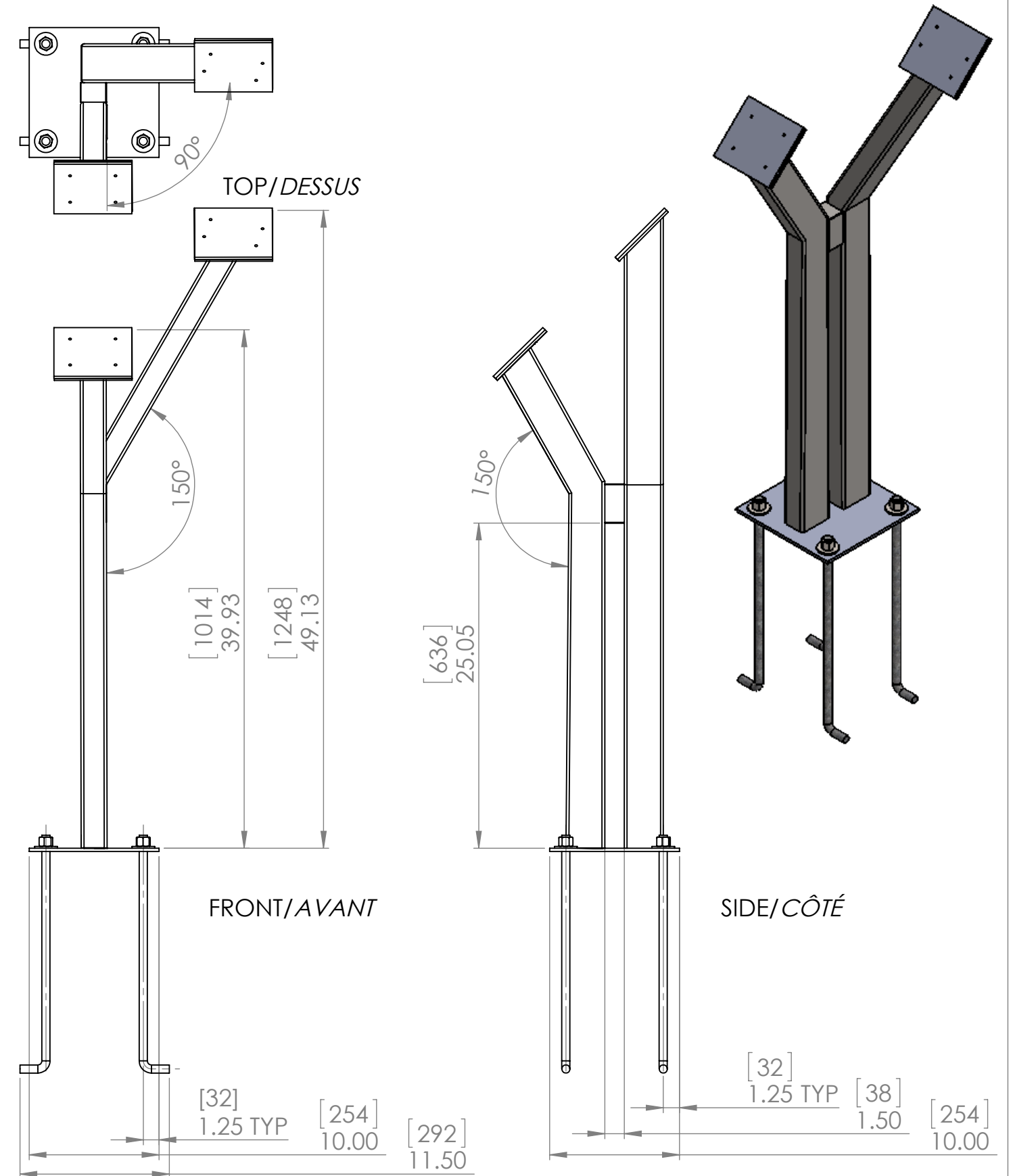

RIDEAU CANAL PROMENADE: GENERAL ASSEMBLY LEFT LEG ASSEMBLY
/ PROMENADE DU CANAL-RIDEAU : ASSEMBLAGE GÉNÉRAL ASSEMBLAGE
PATTE GAUCHE

DRAWN BY / DESSIN PAR : CARRIE HURST

DATE: 05MAY17
DATE : 05MAI17

REVISIONS/RÉVISIONS :

DRAWING / DESSIN :
SA-LL-A-01

REVISED / RÉVISÉ PAR :

DATE:



UNIT: INCHES [mm] UNITÉ : POUCES [mm]

SCALE/ÉCHELLE : 1:10

SHEET / FEUILLE : 4

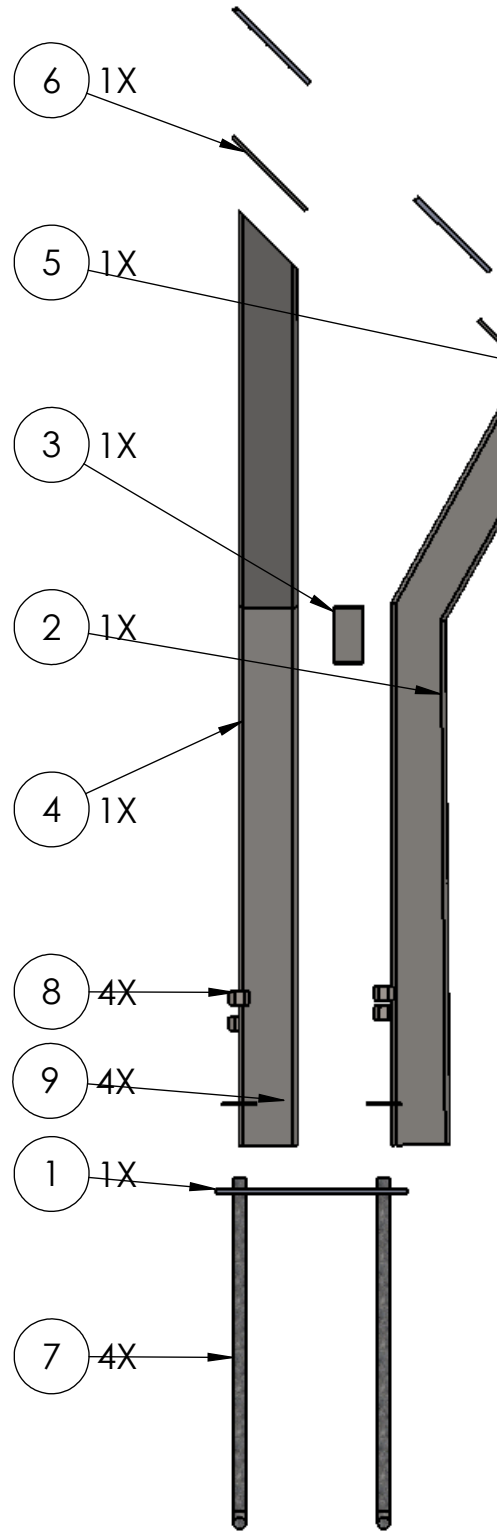

ITEM	NAME	DWG	QTY
ART.	NOM	DESSIN	QUANTITÉ
1	LEG-BASE / PATTE - BASE	L-01	1
2	LEG-FRONT / PATTE - AVANT	L-02	1
3	LEG-MID / PATTE - CENTRE	L-03	1
4	LEG-R-BACK / PATTE - D - ARRIÈRE	L-05	1
5	LEG-PANEL-PLATE-F	L-06	1
6	LEG-PANEL-PLATE-R	L-07	1
7	CONCRETE FOOTING ROD:DESC: Grade 55 Hot Dipped Galvanized Length of Bend: 1" Length of Thread: 2" NOTE: RODS ARE NOT PART OF METAL FABRCIATION - THEY WILL BE SUPPLIED AND INSTALLED BY NCC LA CONTRACTOR / TIGE DE BASE DE BÉTON : DESCR. : classe 55 Galvanisé par immersion à chaud Longueur du cintrage : 1 po Longueur du filetage : 2 po REMARQUE : LES TIGES SONT EXCLUES DE LA FABRICATION DES ÉLÉMENTS EN MÉTAL - ELLES SERONT FOURNIES ET INSTALLÉES PAR UN ENTREPRENEUR DE LA CCN		4
8	5/8" GALVANIZED HEAVY NUT / ÉCROU GALVANISÉ LARGE 0,625 PO		4
9	5/8" STAINLESS STEEL WASHER / RONDELLE EN ACIER INOXYDABLE 0,625 PO		4

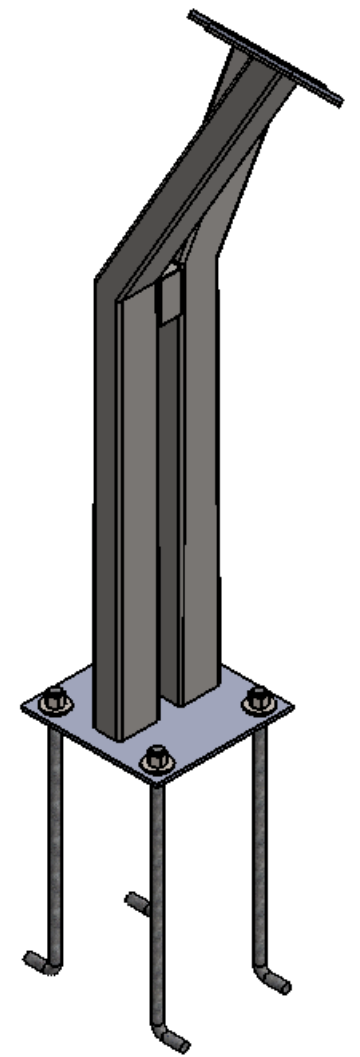
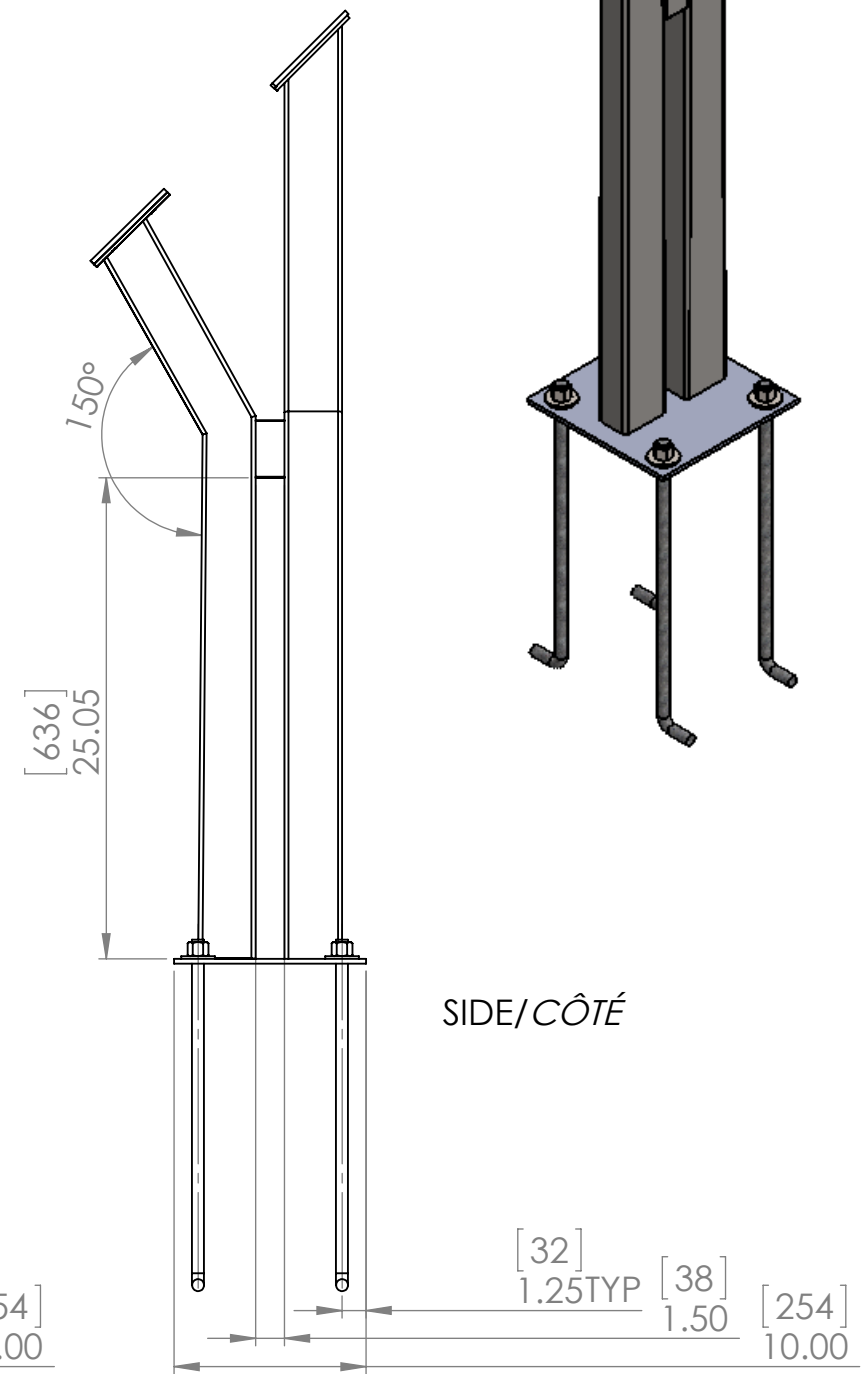
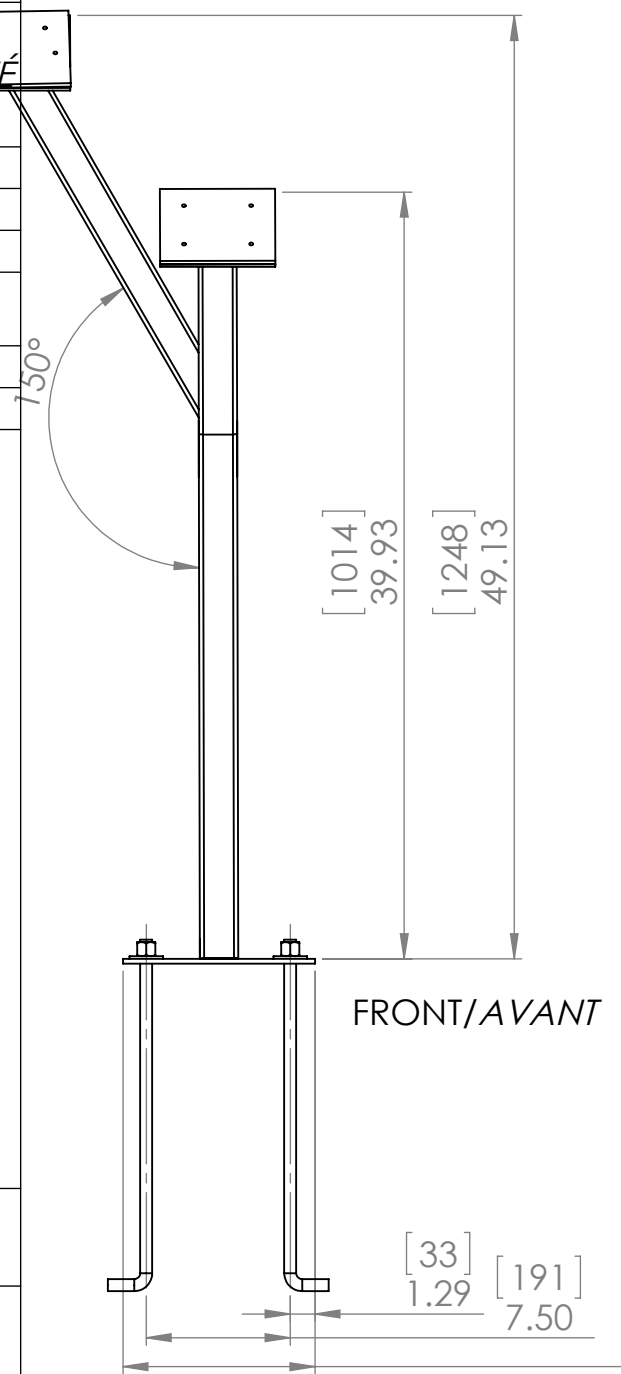
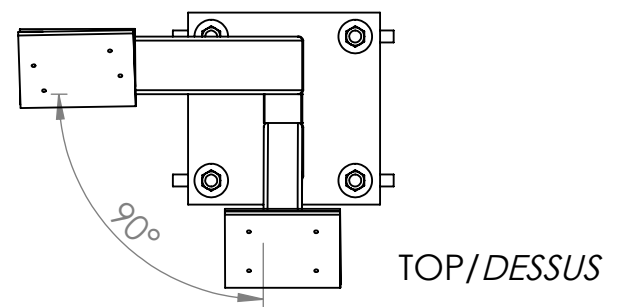

RIDEAU CANAL PROMENADE: GENERAL ASSEMBLY RIGHT LEG ASSEMBLY
/ PROMENADE DU CANAL-RIDEAU : ASSEMBLAGE GÉNÉRAL ASSEMBLAGE
PATTE DROITE



DRAWN BY / DESSIN PAR : CARRIE HURST

DATE: 05MAY17
DATE : 05MAI17

REVISIONS/RÉVISIONS :

DRAWING / DESSIN :
SA-RL-A-01

REVISED / RÉVISÉ PAR :

DATE:

UNIT: INCHES [mm] UNITÉ : POUCES [mm]

SCALE/ÉCHELLE :

SHEET / FEUILLE : 5

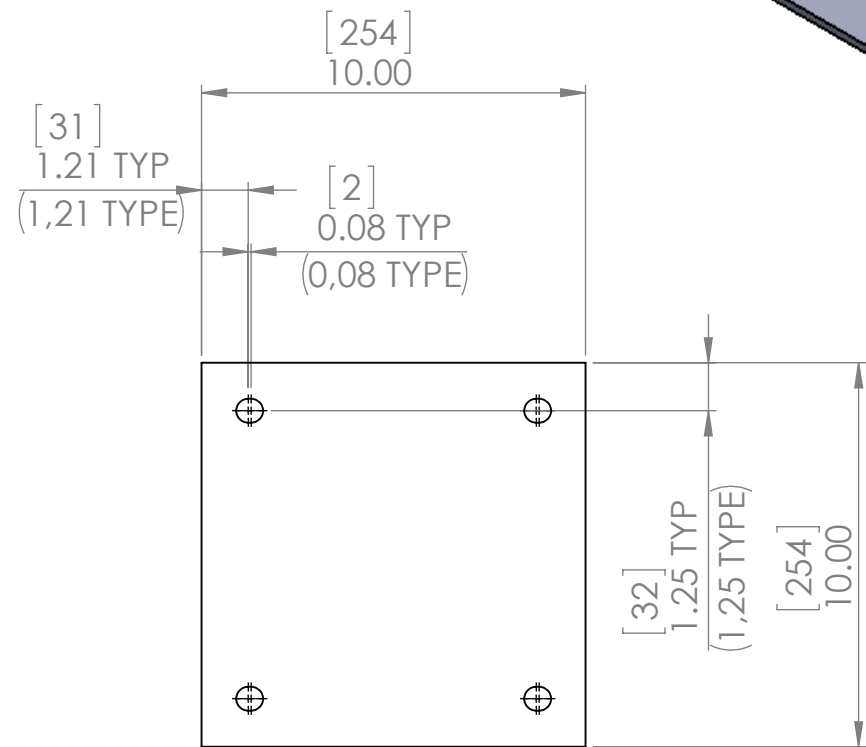
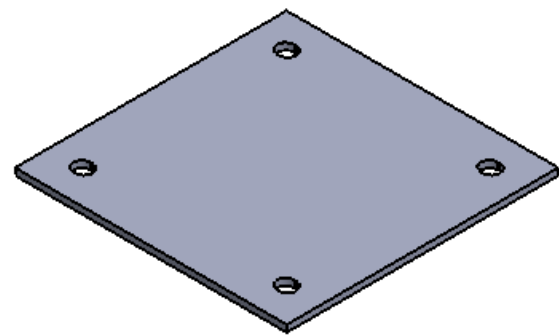

TOP/DESSUS

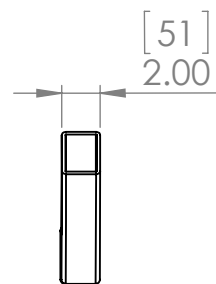

TOP/DESSUS

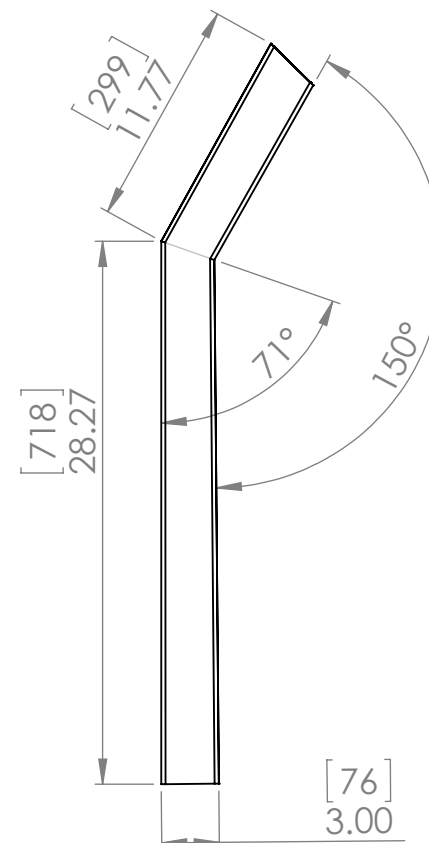
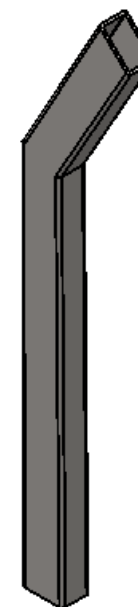

SIDE/CÔTÉ

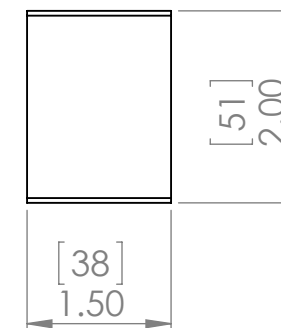

TOP/DESSUS

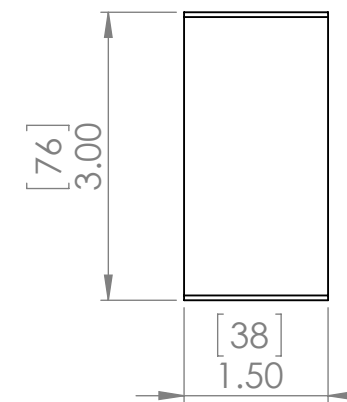
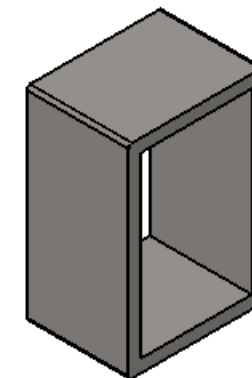

FRONT/AVANT

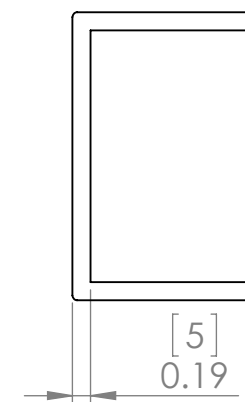

SIDE/CÔTÉ



FRONT/AVANT



SIDE/CÔTÉ

DWG: L-01
DESC: LEG BASE
SCALE: 1:10
MATERIAL: 0.25" STAINLESS STEEL
FINISH: MILL FINISH

DESS.: L-01
DESCR.: BASE DE PATTE
ÉCHELLE: 1:10
MATÉRIAU: ACIER INOXYDABLE 0,25 PO
FINI: BRUT

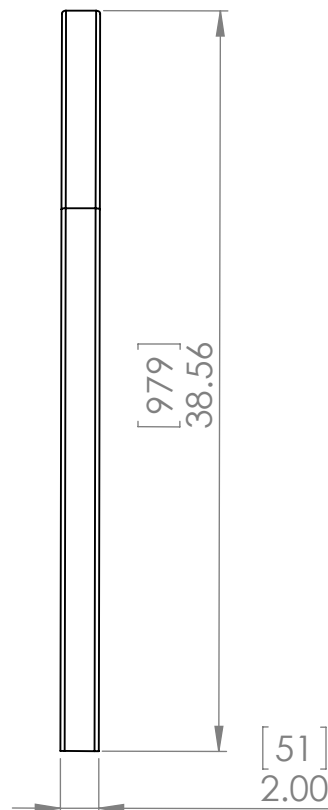

FRONT/AVANT

DWG: L-02
DESC: LEG FRONT
SCALE: 1:10
MATERIAL: 3" X 2"
WALL THICKNESS 0.188"
FINISH: BRUSH POLISHED

DESS.: L-02
DESCR.: AVANT DE PATTE
ÉCHELLE: 1:10
MATÉRIAU: 3 PO X 2 PO,
ÉPAISSEUR DE
PAROI 0,188 PO
FINI: BROSSÉ

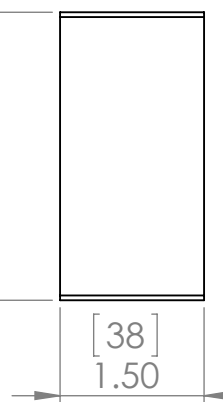

FRONT/AVANT

DWG: L-03
DESC: LEG MIDDLE
SCALE: 1:2
MATERIAL: 3" X 2"
WALL THICKNESS 0.188"
FINISH: BRUSH POLISHED

DESS.: L-03
DESCR.: PIÈCE CENTRE DE PATTE
ÉCHELLE: 1:2
MATÉRIAU: 3 PO X 2 PO,
ÉPAISSEUR DE
PAROI 0,188 PO
FINI: BROSSÉ

RIDEAU CANAL PROMENADE: UNIVERSAL LEG PARTS
/ PROMENADE DU CANAL-RIDEAU : DE PATTE UNIVERSELLES

DRAWN BY / DESSIN PAR : CARRIE HURST

DATE: 05MAY17
DATE : 05MAI17

REVISIONS/RÉVISIONS :

DRAWING / DESSIN :

REVISED / RÉVISÉ PAR :

DATE:

L-01 L-02 L-03

UNIT: INCHES [mm] UNITÉ: POUCES [mm]

SCALE/ÉCHELLE :

SHEET / FEUILLE : 6



Canadian Heritage
Patrimoine canadien



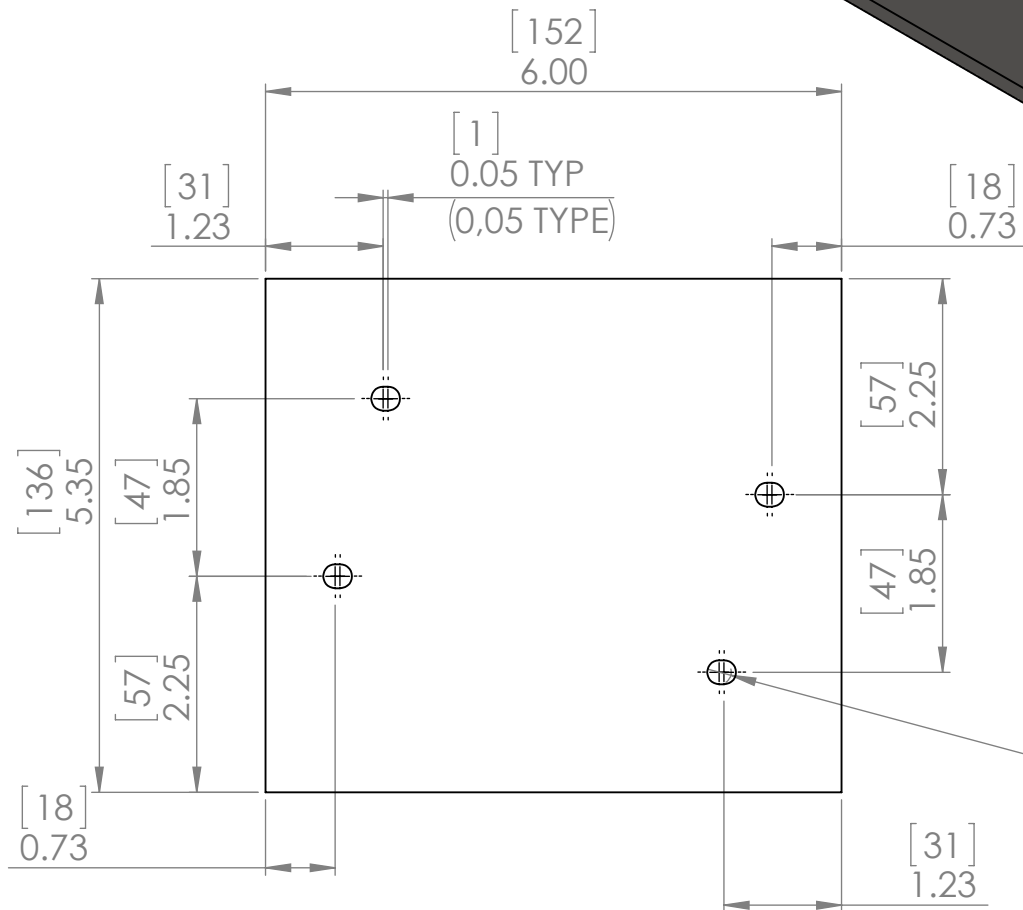

TOP/DESSUS

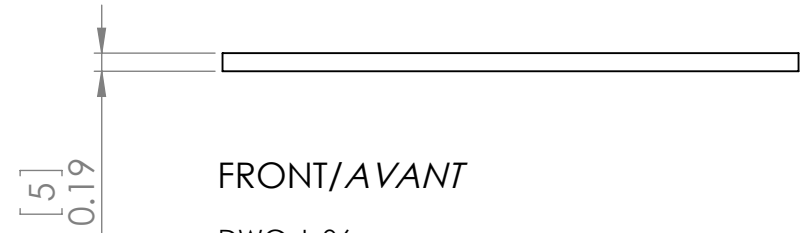

FRONT/AVANT

DWG: L-06
 DESC: LEG-PANEL-PLATE-FRONT
 SCALE: 1:2
 MATERIAL: 0.19" STAINLESS STEEL PLATE
 FINISH: BRUSH POLISH COSMETIC SIDE

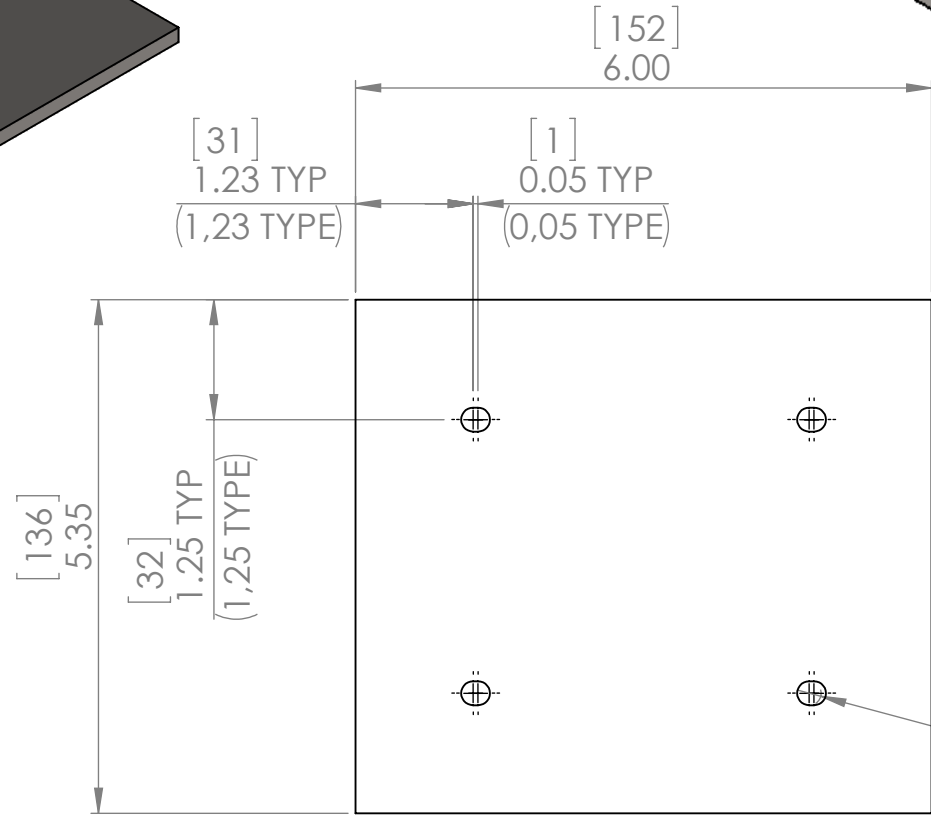
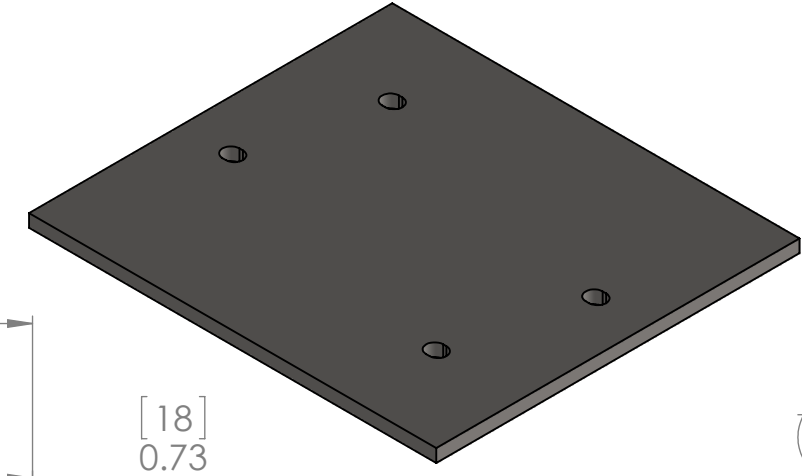

TOP/DESSUS

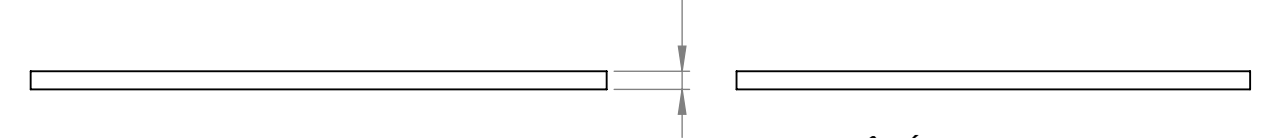

FRONT/AVANT

DWG: L-07
 DESC: LEG-PANEL-PLATE-REAR
 SCALE: 1:2
 MATERIAL: 0.19" STAINLESS STEEL PLATE
 FINISH: BRUSH POLISH COSMETIC SIDE

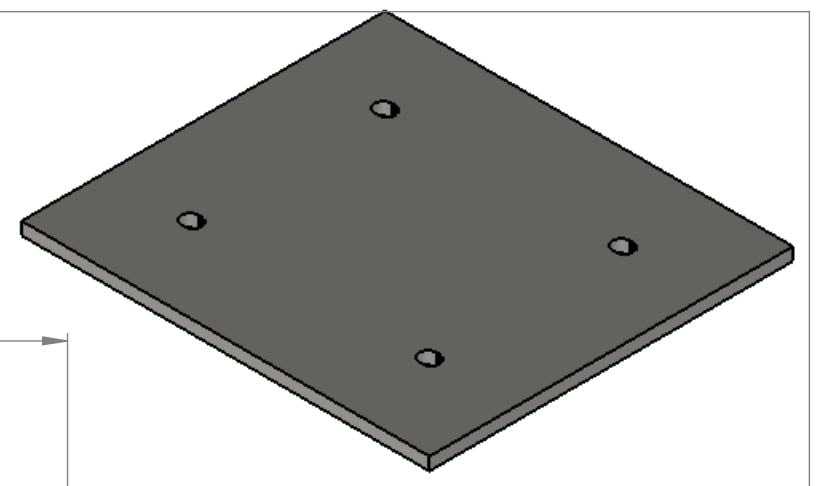

SIDE/CÔTÉ

DESS. : L-07
 DESCR. : PATTE-PANNEAU-PLAQUE-ARRIÈRE
 ÉCHELLE : 1:2
 MATÉRIAU : PLAQUE EN ACIER INOXYDABLE
 0,19 PO
 FINI : CÔTÉ APPARENT BROSSÉ

RIDEAU CANAL PROMENADE: UNIVERSAL LEG PARTS
 / PROMENADE DU CANAL-RIDEAU : DE PATTE UNIVERSELLES



DRAWN BY / DESSIN PAR : CARRIE HURST
 DATE: 05MAY17
 DATE : 05MAI17
 REVISED / RÉVISÉ PAR :
 UNIT: INCHES [mm] UNITÉ : POUCES [mm]

SCALE/ÉCHELLE :

REVISIONS/RÉVISIONS :

DRAWING / DESSIN :
 L-06 L-07
 SHEET / FEUILLE : 7

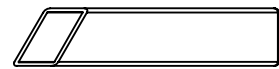

TOP/DESSUS

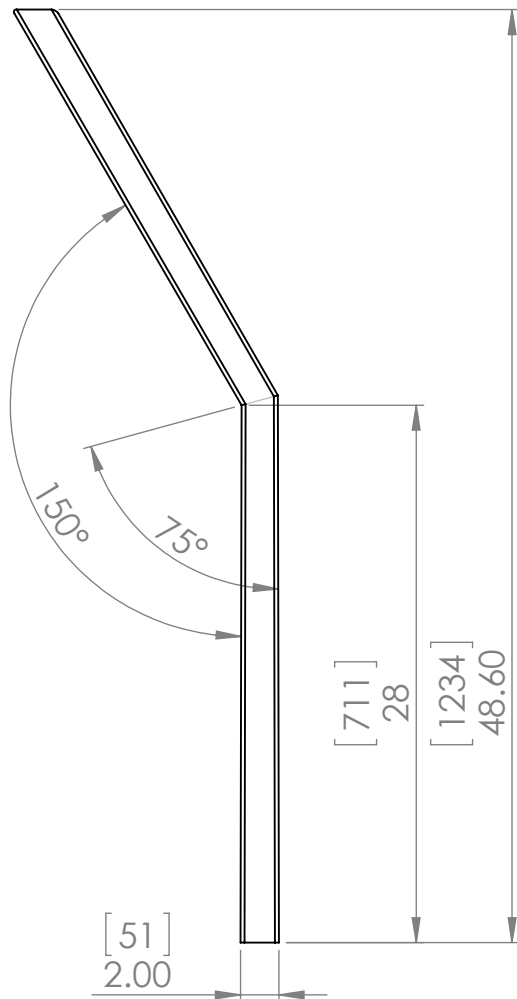

FRONT/AVANT

DWG: L-04
 DESC: LEG LEFT BACK
 SCALE: 1:10
 MATERIAL: 3" X 2" WALL THICKNESS 0.188"
 FINISH: BRUSH POLISHED

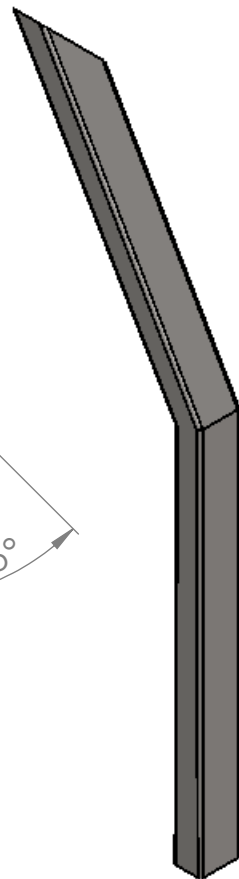

TOP/DESSUS

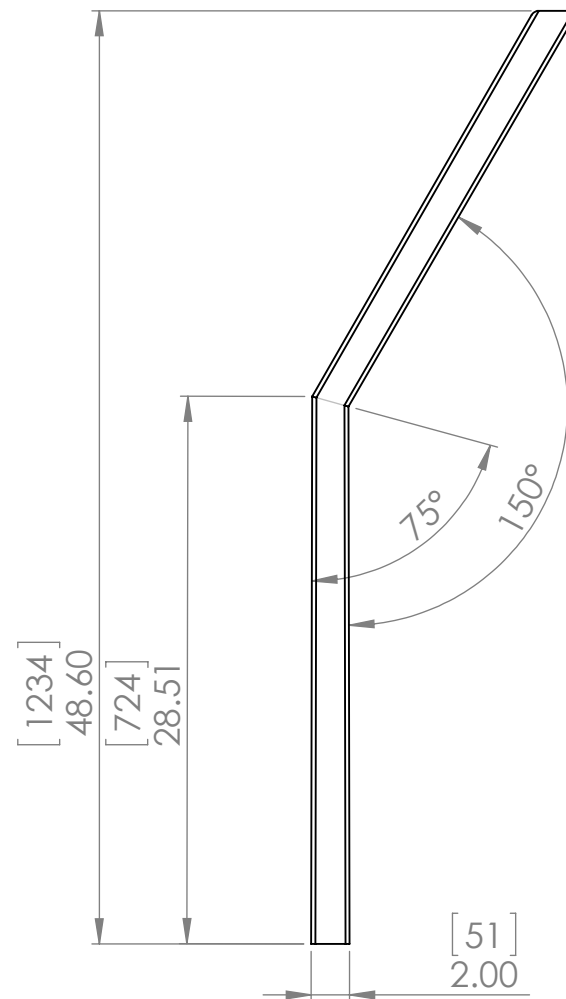

FRONT/AVANT

DWG: L-05
 DESC: LEG RIGHT BACK
 SCALE: 1:10
 MATERIAL: 3" X 2" WALL THICKNESS 0.188"
 FINISH: BRUSH POLISHED

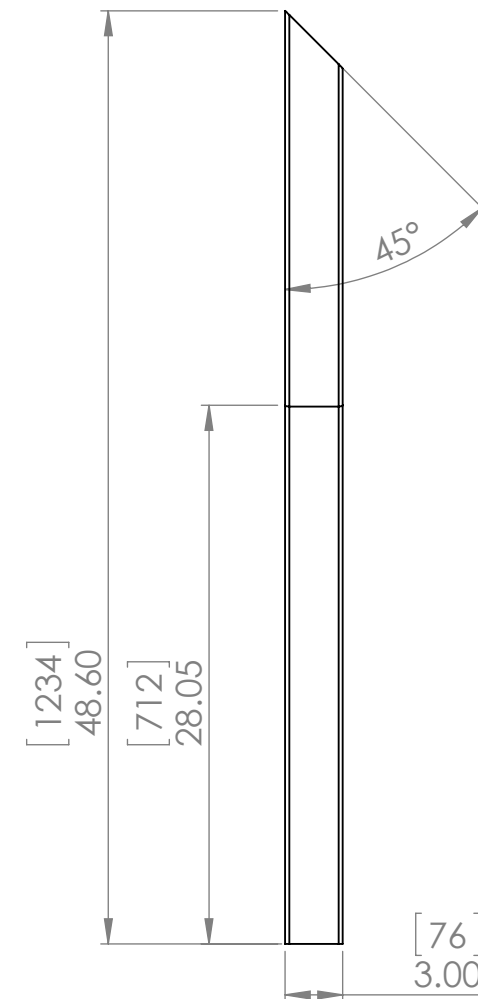
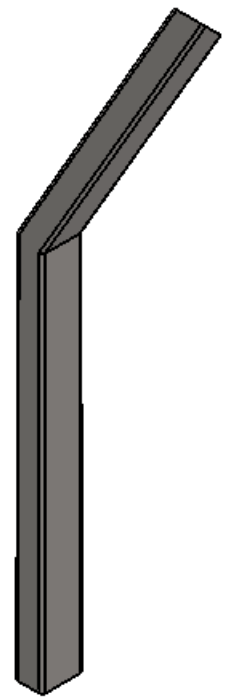

SIDE/CÔTÉ

DESS.: L-05
 DESCR.: PATTE ARRIÈRE DROITE
 ÉCHELLE: 1:10
 MATÉRIAU: 3 PO X 2 PO, ÉPAISSEUR DE PAROI 0,188 PO
 FINI: BROSSÉ

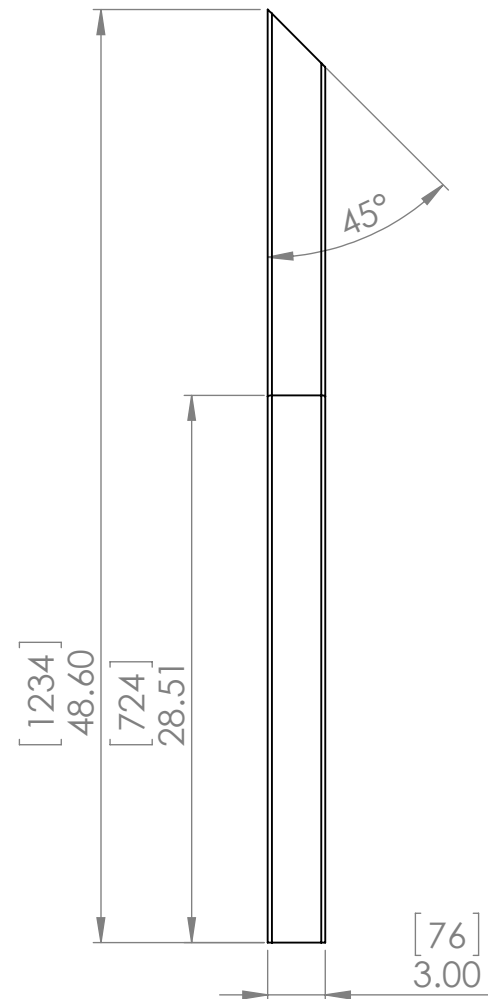

SIDE/CÔTÉ

DESS.: L-04
 DESCR.: PATTE ARRIÈRE GAUCHE
 ÉCHELLE: 1:10
 MATÉRIAU: 3 PO X 2 PO, ÉPAISSEUR DE PAROI 0,188 PO
 FINI: BROSSÉ

RIDEAU CANAL PROMENADE: PARTS BACK LEFT AND BACK RIGHT LEG
/ PROMENADE DU CANAL-RIDEAU : DES PATTES ARRIÈRE GAUCHE ET DROITE

DRAWN BY / DESSIN PAR : CARRIE HURST

DATE: 05MAY17
 DATE : 05MAI17

REVISIONS/RÉVISIONS :

DRAWING / DESSIN :

REVISED / RÉVISÉ PAR :

DATE:

L-04 L-05

UNIT: INCHES [mm] UNITÉ : POUCES [mm]

SCALE/ÉCHELLE :

SHEET / FEUILLE : 8



Canadian Heritage

Patrimoine canadien



1 1X

2 2X

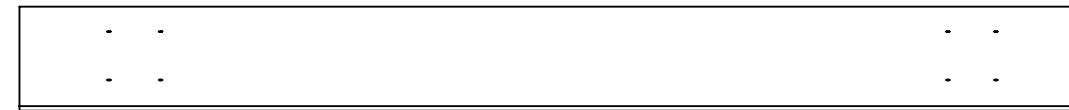
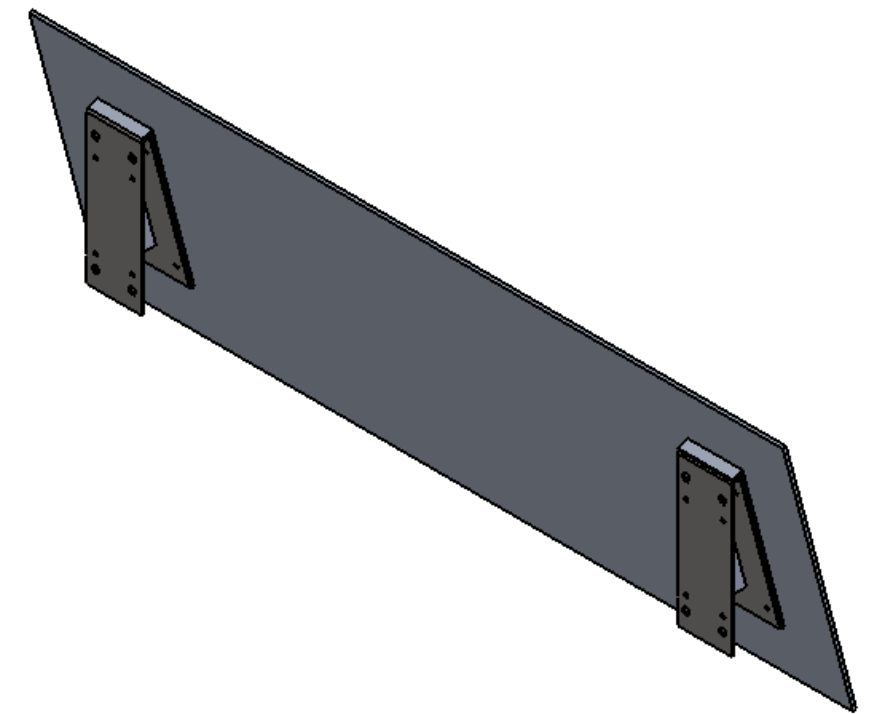
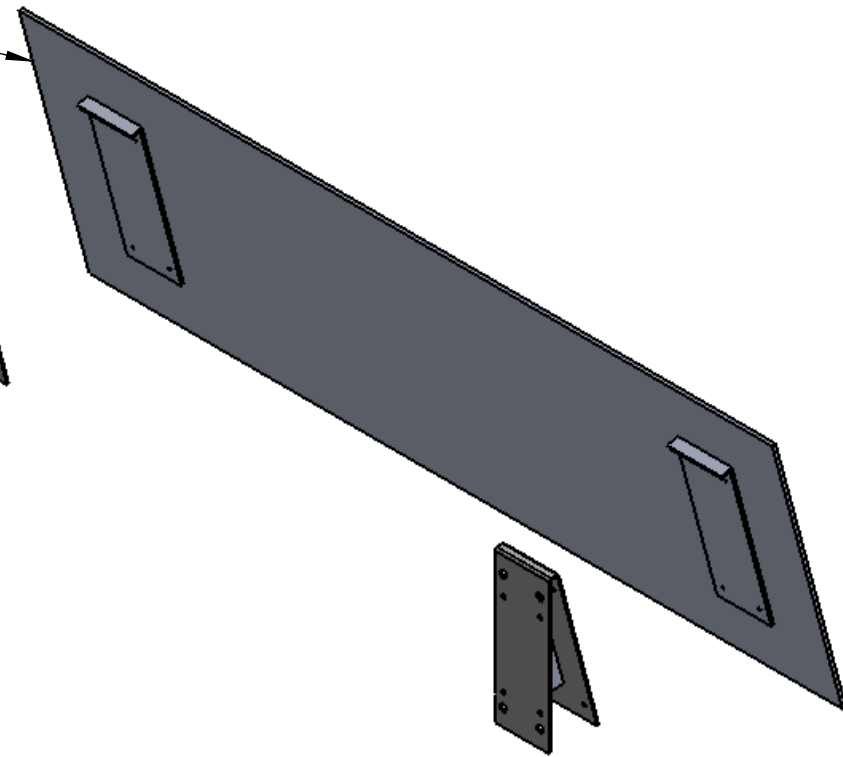

[102]
4.00 TYP
(4,00 TYPE)



[96]
3.80 TYP
(3,80 TYPE)

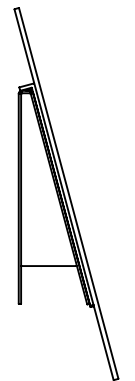

ITEM	NAME	DWG	QTY
ART.	NOM	DESSIN	QUANTITÉ
1	GRAPHIC PANEL ASSY - BY OTHERS / ASS. PANNEAU GRAPHIQUE - PAR DES TIERS	WB-PL-A	1
2	WALL BRACKET ASSY / ASSEMBLAGE DU SUPPORT MURAL	WB-PL-GA	2

RIDEAU CANAL PROMENADE: GENERAL ASSEMBLY WALL BRACKET AND PANEL
/ PROMENADE DU CANAL-RIDEAU : ASSEMBLAGE GÉNÉRAL - PANNEAU ET SUPPORT MURAL



DRAWN BY / DESSIN PAR : CARRIE HURST

DATE: 05MAY17
DATE : 05MAI17

REVISIONS/RÉVISIONS :

DRAWING / DESSIN :

REVISED / RÉVISÉ PAR :

DATE:

WB-GA-01

UNIT: INCHES [mm] UNITÉ : POUCES [mm]

SCALE/ÉCHELLE :

SHEET / FEUILLE : 9

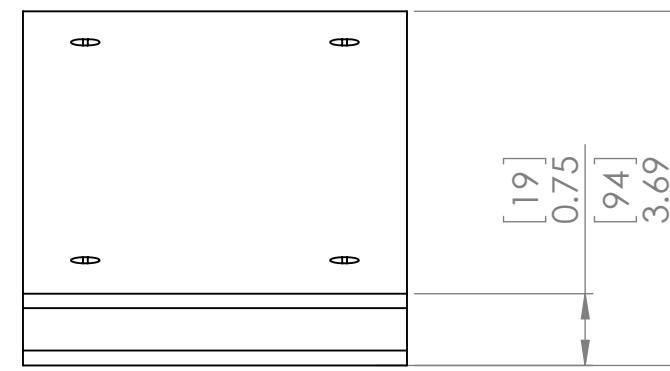
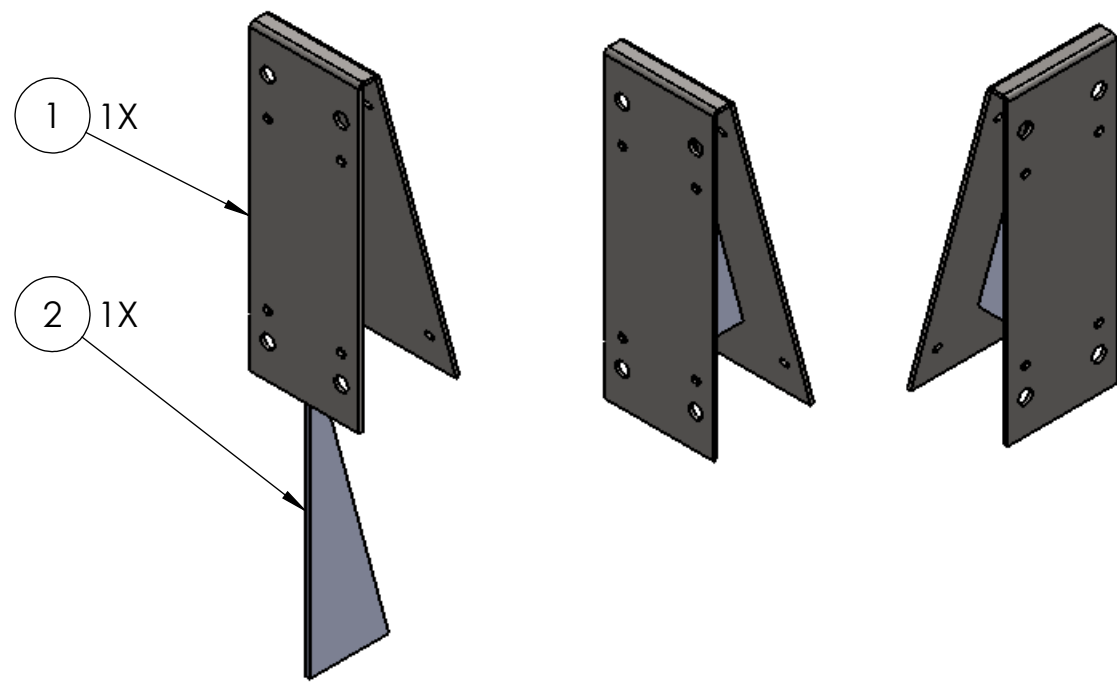

TOP / DESSUS

[102]
4.00

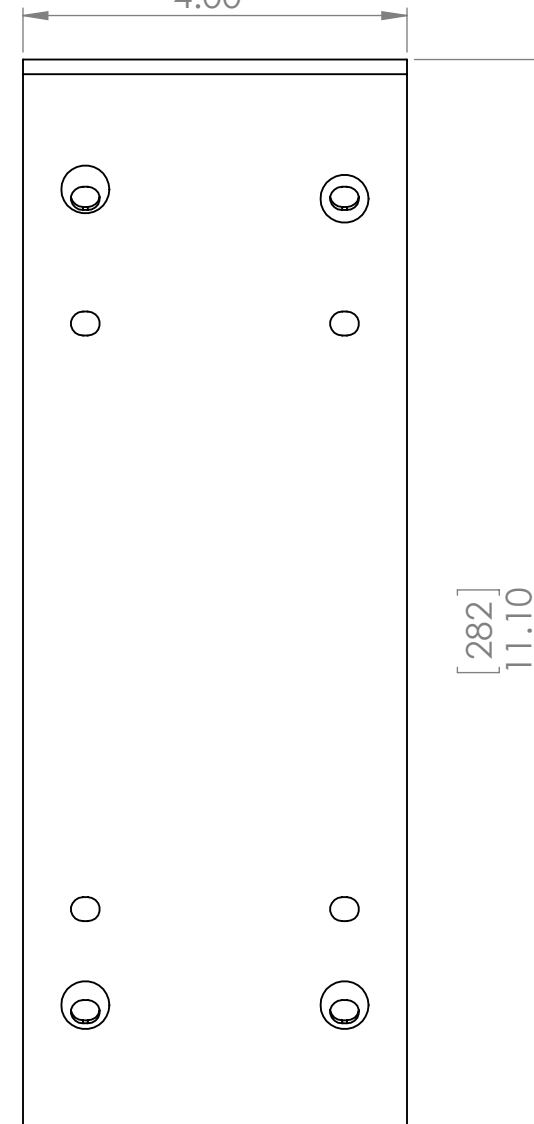

FRONT/ AVANT

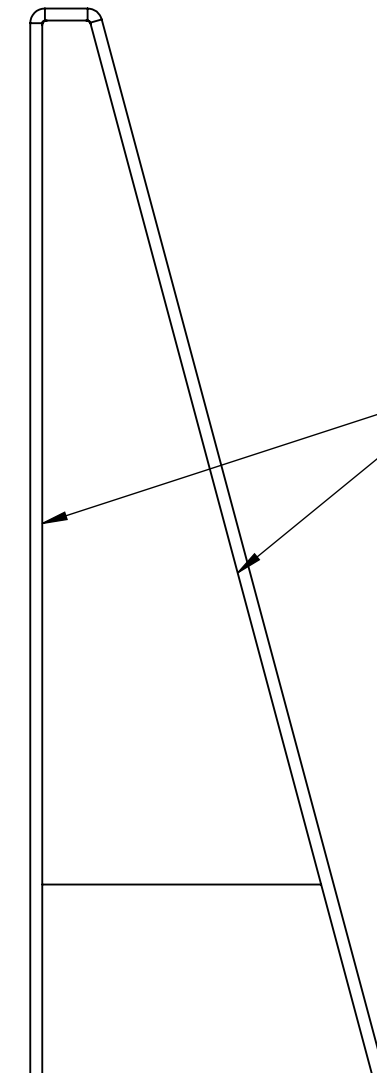

SIDE / CÔTÉ

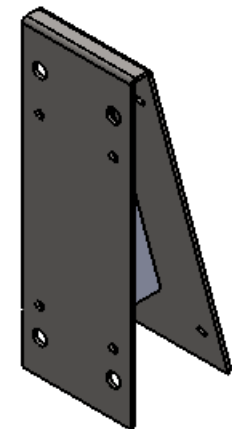

WELD GUSSET TO BRACKET
BOTH SIDES OF GUSSET /
SOUDER LE GOUSSET
AU SUPPORT
DE CHAQUE CÔTÉ
DU GOUSSET

ITEM ART.	NAME NOM	DWG DESSIN	QUANTITY QUANTITÉ
1	WALL BRACKET / SUPPORT MURAL	WB-PT-01	1
2	GUSSET / GOUSSET	WB-PT-02	1

RIDEAU CANAL PROMENADE: GENERAL ASSEMBLY WALL BRACKET
/ PROMENADE DU CANAL-RIDEAU : ASSEMBLAGE GÉNÉRAL - SUPPORT

DRAWN BY / DESSIN PAR : CARRIE HURST

DATE: 05MAY17
DATE : 05MAI17

REVISIONS/RÉVISIONS :

DRAWING / DESSIN :

WB-GA-01

REVISED / RÉVISÉ PAR :

DATE:

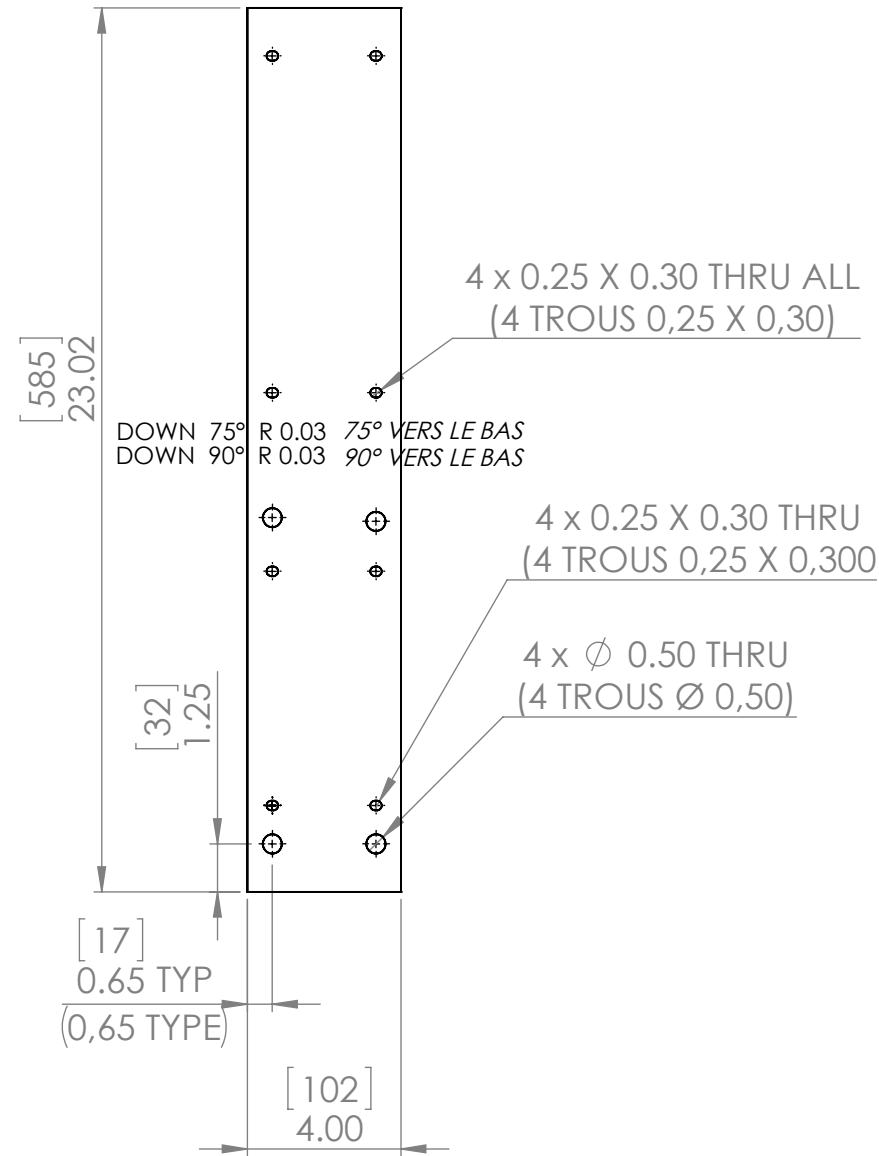
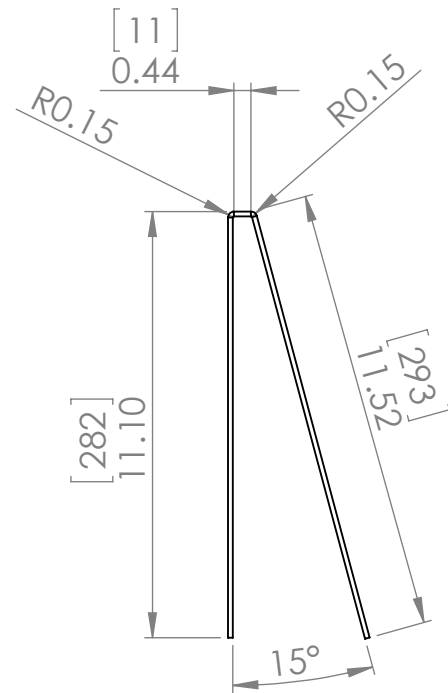
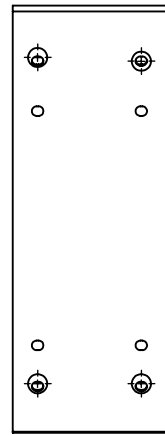
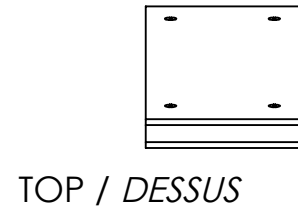

TOP / DESSUS



FRONT / AVANT

DWG:WB-PT-02
 DESC: GUSSET
 SCALE: 1:5
 MATERIAL: 0.19" STAINLESS STEEL PLATE
 FINISH: BRUSH POLISH COSMETIC SIDE

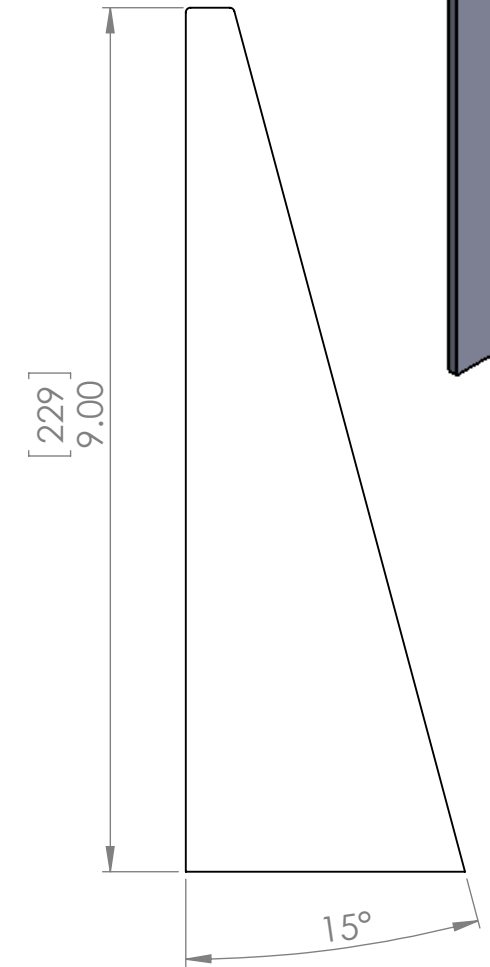

SIDE / CÔTÉ

DESS.:WB-PT-02
 DESCR.: GOUSSET
 ÉCHELLE: 1:5
 MATÉRIAU: PLAQUE EN ACIER INOXYDABLE 0,19 PO
 SIDE FINI: CÔTÉ APPARENT BROSSÉ

RIDEAU CANAL PROMENADE: WALL BRACKET PARTS
/ PROMENADE DU CANAL-RIDEAU: PIÈCES DU SUPPORT MURAL

DRAWN BY / DESSIN PAR : CARRIE HURST

DATE: 05MAY17
 DATE : 05MAI17

REVISIONS/RÉVISIONS:

DRAWING / DESSIN :

WB-PT-01 WB-PT-02

REVISED / RÉVISÉ PAR :

DATE: