

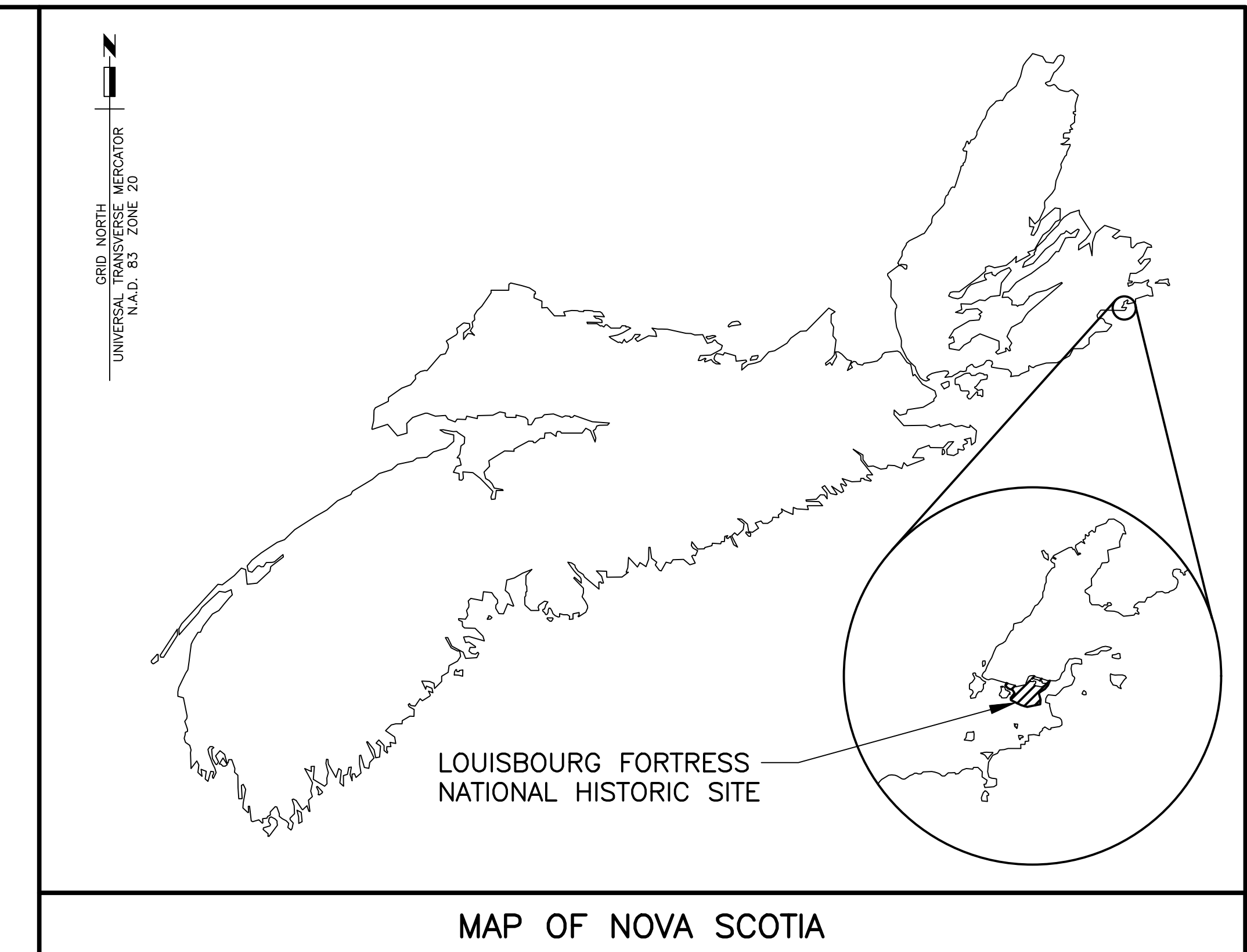

Parcs
Canada



MAP OF NOVA SCOTIA

BARRIER BEACH GROYNES AND RENOURISHMENT FORTRESS OF LOUISBOURG NATIONAL HISTORIC SITE LOUISBOURG, N.S.

DRAWING LIST

C-1	EXISTING CONDITIONS
C-2	BARRIER BEACH STABILIZATION
C-3	TYPICAL GROYS SECTION
C-4	TYPICAL BEACH FILL AND GROYS SECTIONS
C-5	CLEARED ARCHAEOLOGY AREAS

PROJECT NO. 578

**Canada**

ISSUED FOR TENDER
AUGUST 22, 2017

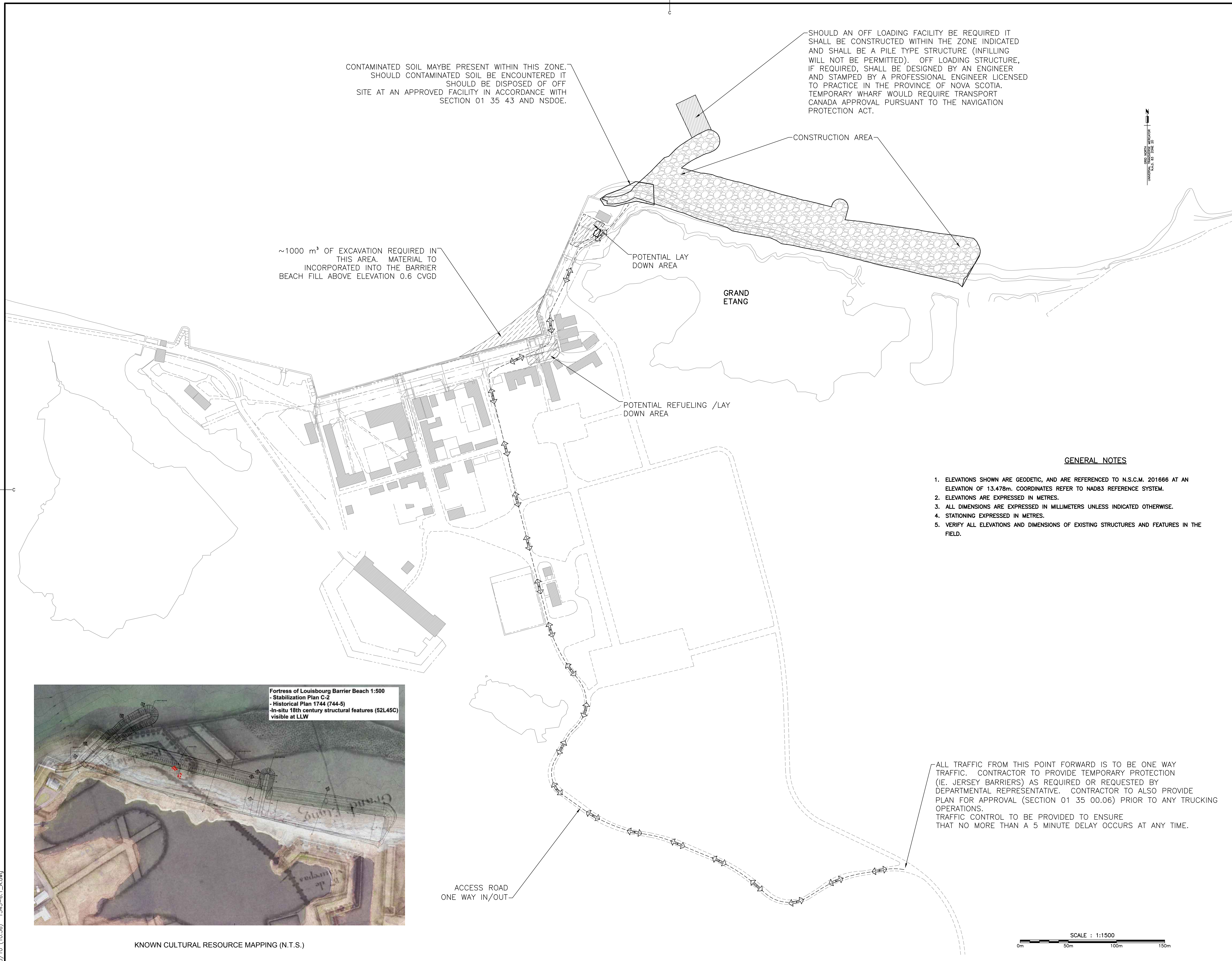

CONTAMINATED SOIL MAYBE PRESENT WITHIN THIS ZONE. SHOULD CONTAMINATED SOIL BE ENCOUNTERED IT SHOULD BE DISPOSED OF OFF SITE AT AN APPROVED FACILITY IN ACCORDANCE WITH SECTION 01 35 43 AND NSDOE.

SHOULD AN OFF LOADING FACILITY BE REQUIRED IT SHALL BE CONSTRUCTED WITHIN THE ZONE INDICATED AND SHALL BE A PILE TYPE STRUCTURE (INFILLING WILL NOT BE PERMITTED). OFF LOADING STRUCTURE, IF REQUIRED, SHALL BE DESIGNED BY AN ENGINEER AND STAMPED BY A PROFESSIONAL ENGINEER LICENSED TO PRACTICE IN THE PROVINCE OF NOVA SCOTIA. TEMPORARY WHARF WOULD REQUIRE TRANSPORT CANADA APPROVAL PURSUANT TO THE NAVIGATION PROTECTION ACT.

~1000 m³ OF EXCAVATION REQUIRED IN THIS AREA. MATERIAL TO INCORPORATED INTO THE BARRIER BEACH FILL ABOVE ELEVATION 0.6 CVGD

POTENTIAL LAY DOWN AREA

POTENTIAL REFUELING /LAY DOWN AREA

GRAND ETANG

ACCESS ROAD ONE WAY IN/OUT

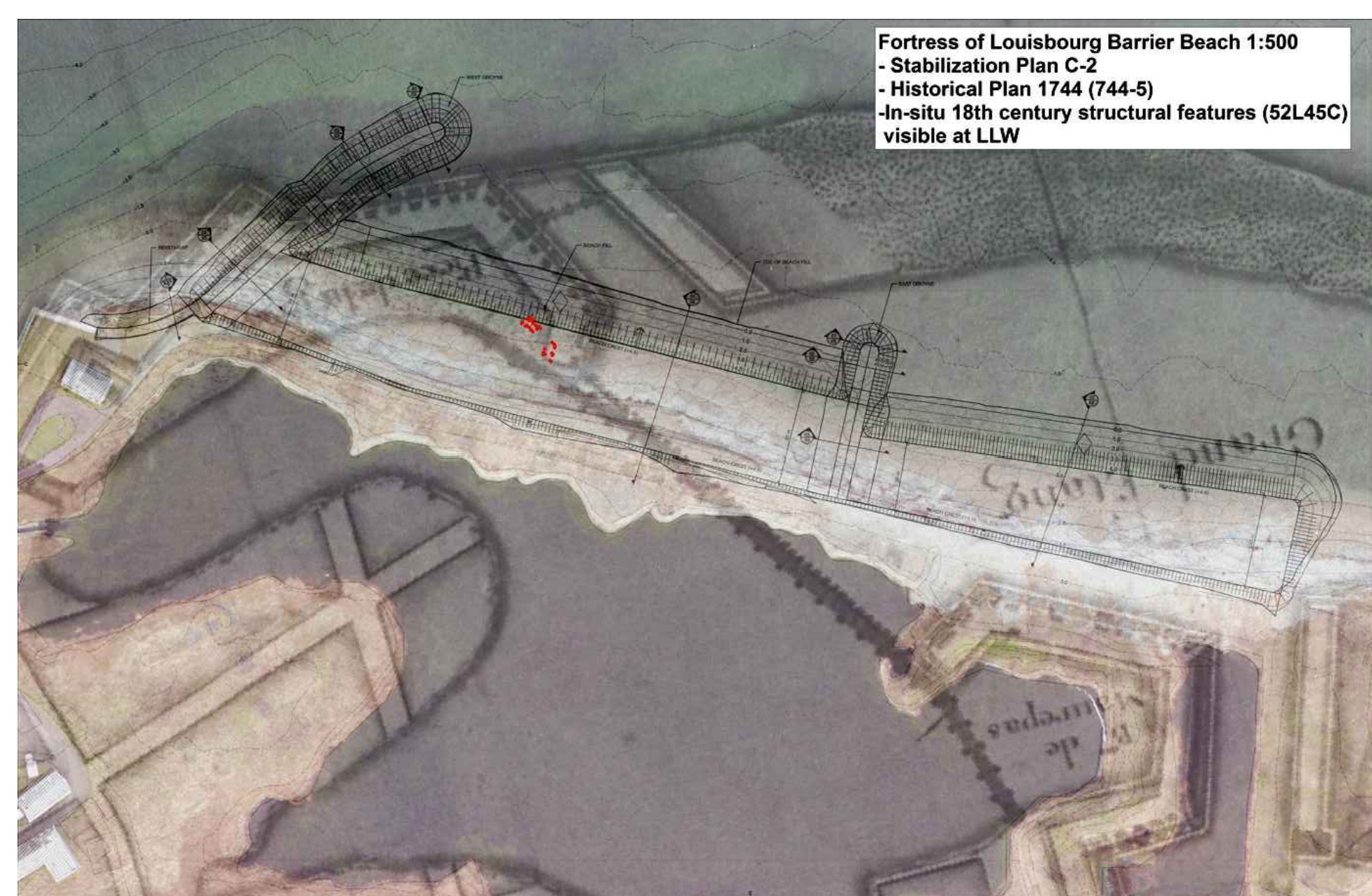

GENERAL NOTES

1. ELEVATIONS SHOWN ARE GEODETIC, AND ARE REFERENCED TO N.S.C.M. 201666 AT AN ELEVATION OF 13.478m. COORDINATES REFER TO NAD83 REFERENCE SYSTEM.
2. ELEVATIONS ARE EXPRESSED IN METRES.
3. ALL DIMENSIONS ARE EXPRESSED IN MILLIMETERS UNLESS INDICATED OTHERWISE.
4. STATIONING EXPRESSED IN METRES.
5. VERIFY ALL ELEVATIONS AND DIMENSIONS OF EXISTING STRUCTURES AND FEATURES IN THE FIELD.

ALL TRAFFIC FROM THIS POINT FORWARD IS TO BE ONE WAY TRAFFIC. CONTRACTOR TO PROVIDE TEMPORARY PROTECTION (IE. JERSEY BARRIERS) AS REQUIRED OR REQUESTED BY DEPARTMENTAL REPRESENTATIVE. CONTRACTOR TO ALSO PROVIDE PLAN FOR APPROVAL (SECTION 01 35 00.06) PRIOR TO ANY TRUCKING OPERATIONS. TRAFFIC CONTROL TO BE PROVIDED TO ENSURE THAT NO MORE THAN A 5 MINUTE DELAY OCCURS AT ANY TIME.

KNOWN CULTURAL RESOURCE MAPPING (N.T.S.)

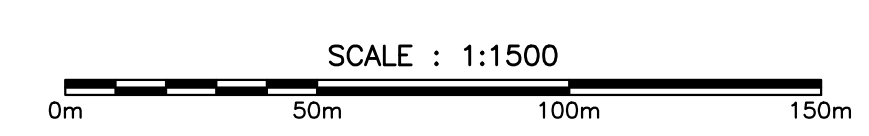

Parcs Canada / Parks Canada

GEMTEC EASTERN JV

Baird
W.F. Baird & Associates
Coastal Engineers Ltd.

LEGEND

	ONE LANE / ONE WAY TRAFFIC
	ONE LANE / TWO WAY TRAFFIC

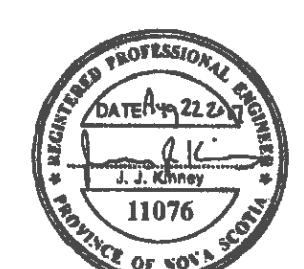

A	ISSUED FOR TENDER	AUG 2017
revisions		date

project: **BARRIER BEACH GROYNES AND RENOURISHMENT**
FORTRESS OF LOUISBOURG
NATIONAL HISTORIC SITE
LOUISBOURG, NS

drawing: **EXISTING CONDITIONS**

designed	JJK	conçu
date	AUG 22, 2017	
drawn	JJK	dessiné
date	AUG 22, 2017	
approved	CK	approuvé
date	AUG 22, 2017	

Tender	AD	Submission
AD	Parcs Project Manager	Administrateur de projets Parcs
project number	578	no. du projet
drawing no.	C-1	no. du dessin

17/03/10 (10:56) 1545-6_1_A.dwg

PWGS C B1 (2004)

E-DRM/GDD-E: C-1

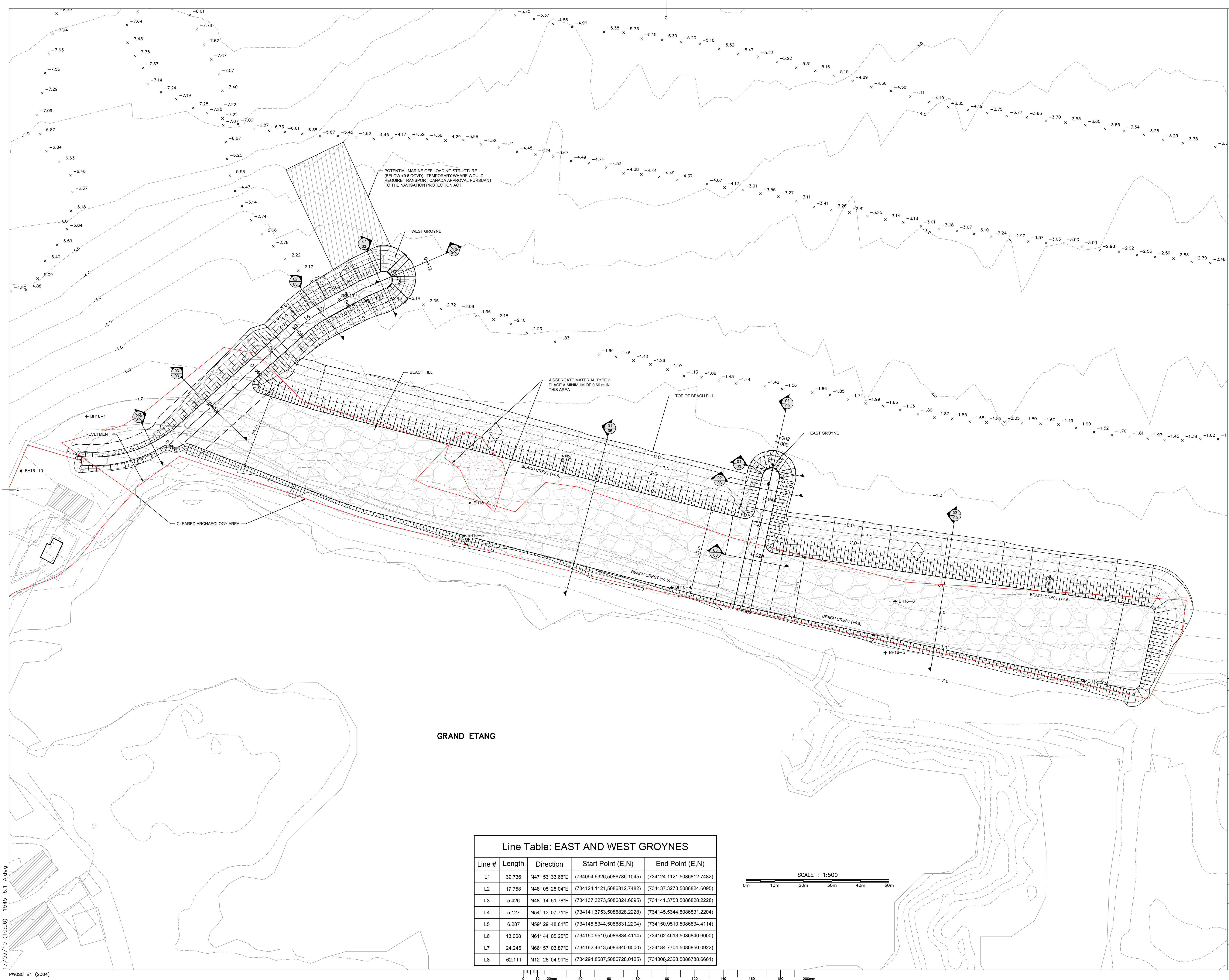

GRAND ETANG

Line Table: EAST AND WEST GROYNES

Line #	Length	Direction	Start Point (E,N)	End Point (E,N)
L1	39.736	N47° 53' 33.66"E	(734094.6326,5086786.1045)	(734124.1121,5086812.7482)
L2	17.758	N48° 05' 25.04"E	(734124.1121,5086812.7482)	(734137.3273,5086824.6095)
L3	5.426	N48° 14' 51.78"E	(734137.3273,5086824.6095)	(734141.3753,5086828.2228)
L4	5.127	N54° 13' 07.71"E	(734141.3753,5086828.2228)	(734145.5344,5086831.2204)
L5	6.287	N59° 29' 48.81"E	(734145.5344,5086831.2204)	(734150.9510,5086834.4114)
L6	13.068	N61° 44' 05.25"E	(734150.9510,5086834.4114)	(734162.4613,5086840.6000)
L7	24.245	N66° 57' 03.87"E	(734162.4613,5086840.6000)	(734184.7704,5086850.0922)
L8	62.111	N12° 26' 04.91"E	(734294.8587,5086728.0125)	(734308.2328,5086788.6661)

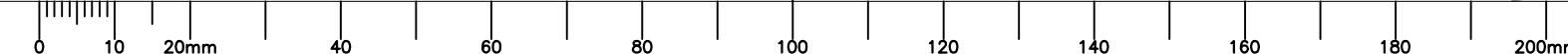
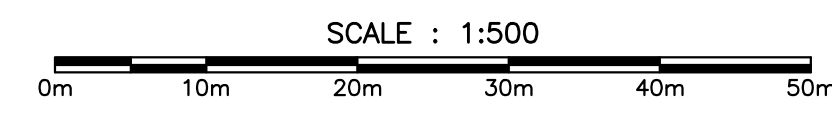

NOTES

- ELEVATIONS SHOWN ARE GEODETIC CGVD28, AND ARE REFERENCED TO N.S.C.M. 201666 AT AN ELEVATION OF 13.478 m. COORDINATES REFER TO NAD83 REFERENCE SYSTEM.
- THE OFFSET FROM CHART DATUM (CD) TO GEODETIC DATUM CGVD28 IS 0.91 M (I.E., 0.91 M CD = 0.0 M CGVD28).

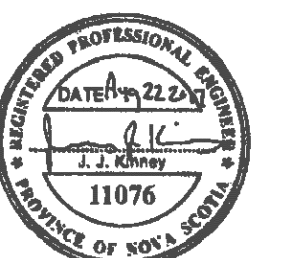

A	ISSUED FOR TENDER	AUG 2017
---	-------------------	----------

revisions		date
project		project

BARRIER BEACH GROYNES AND RENOURISHMENT FORTRESS OF LOUISBOURG NATIONAL HISTORIC SITE LOUISBOURG, NS

drawing design

BARRIER BEACH STABILIZATION

designed JJK	conçu
--------------	-------

date AUG 22, 2017	
-------------------	--

drawn JJK	dessiné
-----------	---------

date AUG 22, 2017	
-------------------	--

approved CK	approuvé
-------------	----------

date AUG 22, 2017	
-------------------	--

Tender	Submission
--------	------------

AD	Administrateur de projets
----	---------------------------

Parcs Project Manager	Administrateur de projets
-----------------------	---------------------------

project number	no. du projet
----------------	---------------

578

drawing no.	no. du dessin
-------------	---------------

C-2

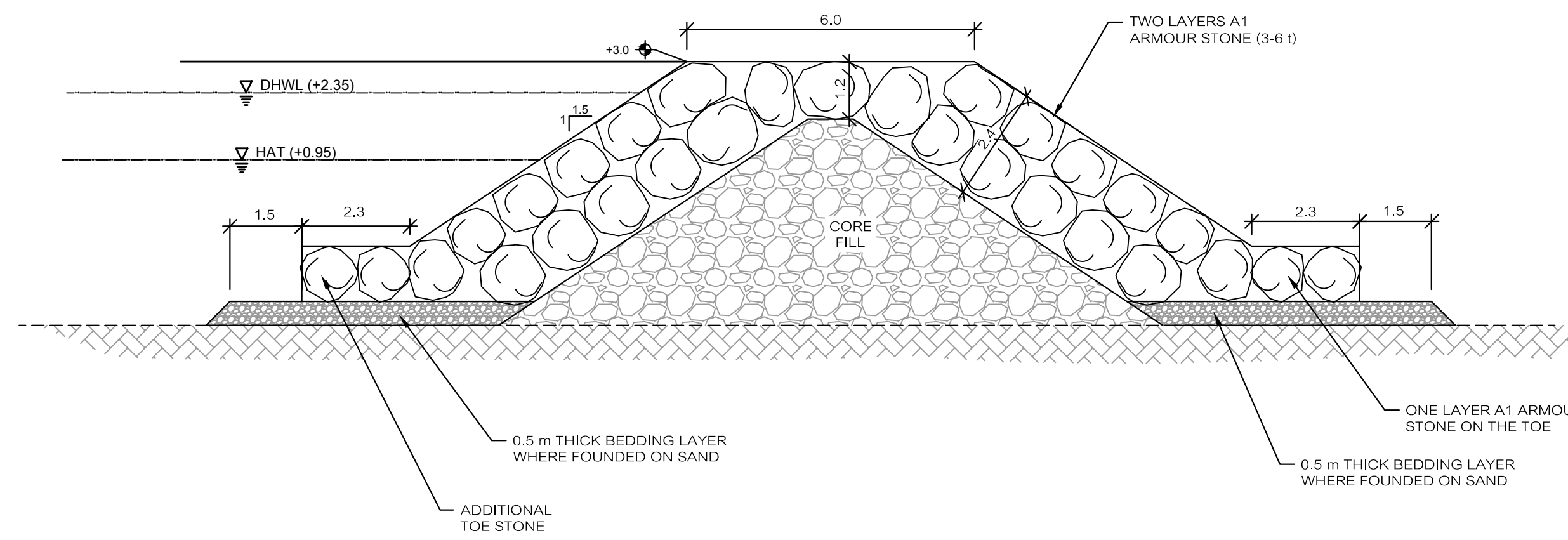

01 HEAD SECTION

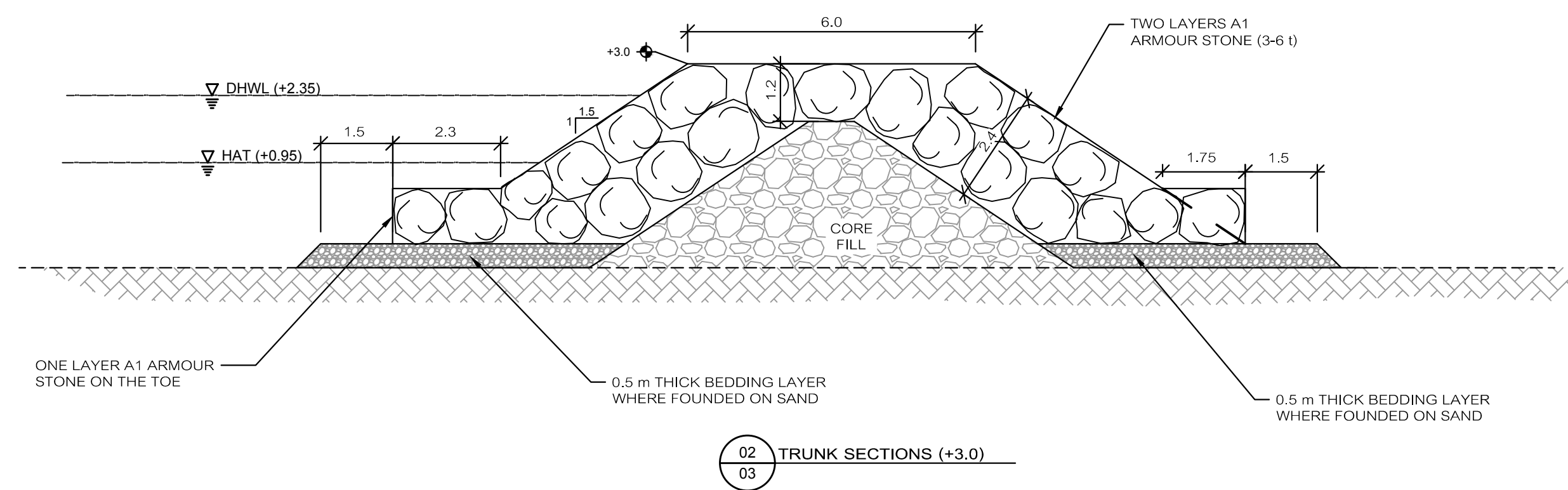

02 TRUNK SECTIONS (+3.0)

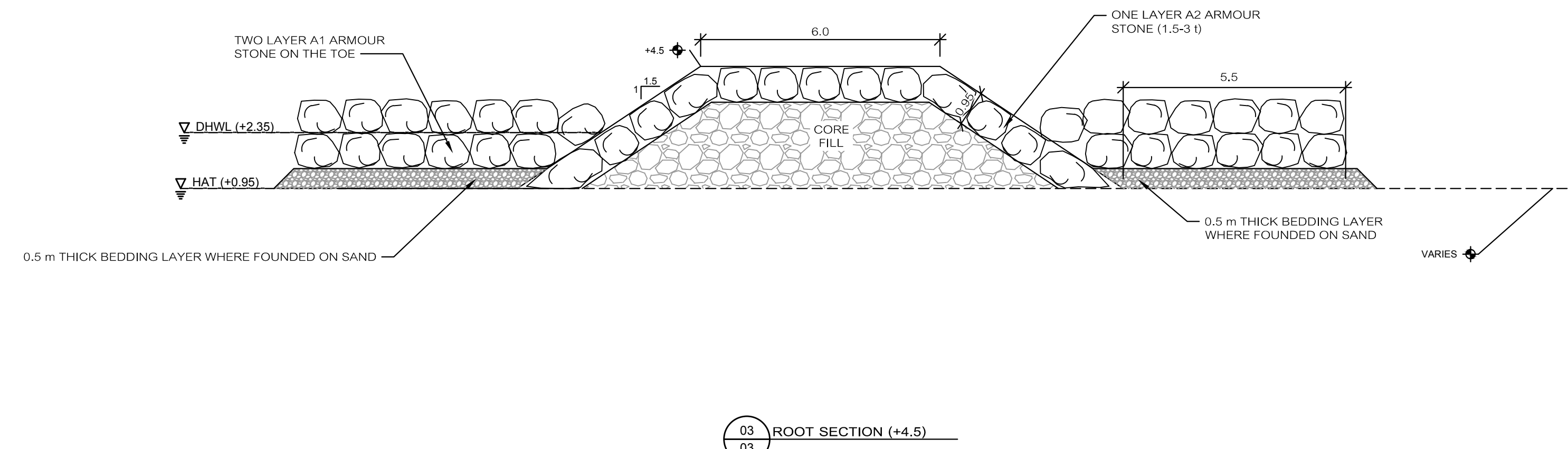

03 ROOT SECTION (+4.5)

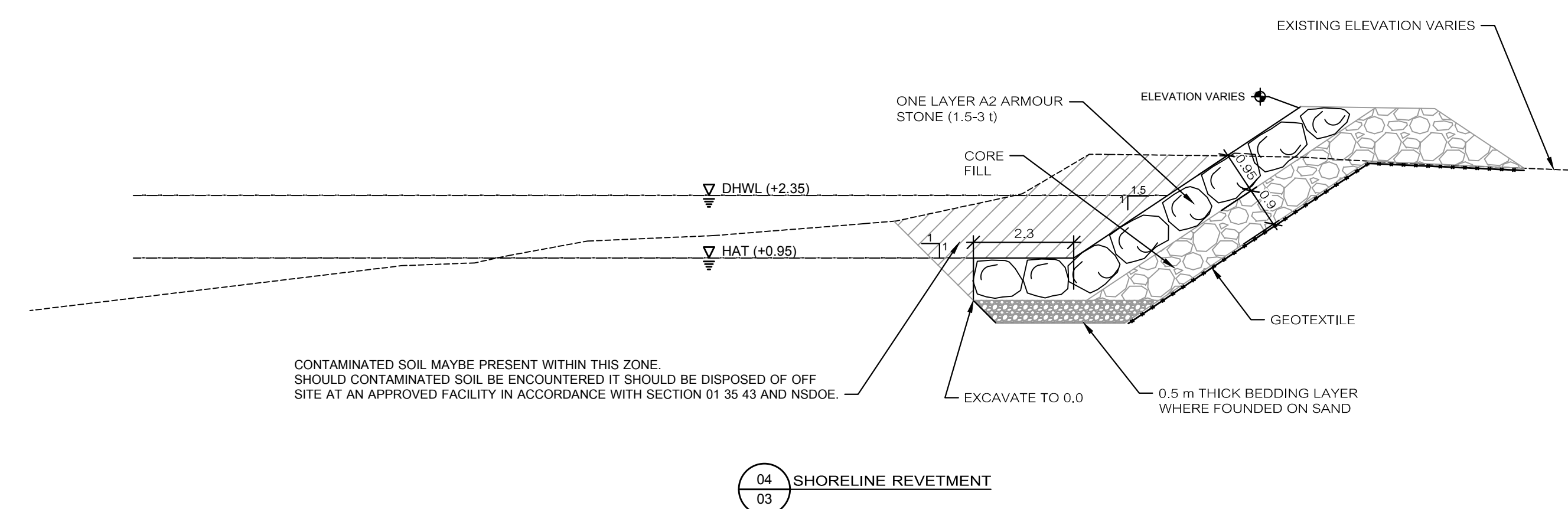

04 SHORELINE REVETMENT

SCALE : 1:100
0m 1m 2m 3m 4m 5m 6m 7m 8m 9m 10m

NOTES:

- ELEVATIONS SHOWN ARE GEODETIC CGVD28, AND ARE REFERENCED TO N.S.C.M. 201666 AT AN ELEVATION OF 13.478 m. COORDINATES REFER TO NAD83 REFERENCE SYSTEM.
- THE OFFSET FROM CHART DATUM (CD) TO GEODETIC DATUM CGVD28 IS 0.91 M (I.E. 0.91 M CD = 0.0 M CGVD28).

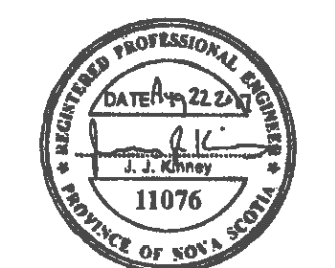

A	ISSUED FOR TENDER	AUG 2017
revisions		date
project		projet

**BARRIER BEACH
GROYNES AND RENOURISHMENT
FORTRESS OF LOUISBOURG
NATIONAL HISTORIC SITE
LOUISBOURG, NS**

TYPICAL GROYNES
SECTIONS

designed	JKK	conçu
date	AUG 22, 2017	
drawn	JKK	dessiné
date	AUG 22, 2017	
approved	CK	approuvé
date	AUG 22, 2017	
Tender	AD	Submission
Parks Project Manager	Administrateur de projets Parks	
project number	578	no. du projet
drawing no.	C-3	no. du dessin

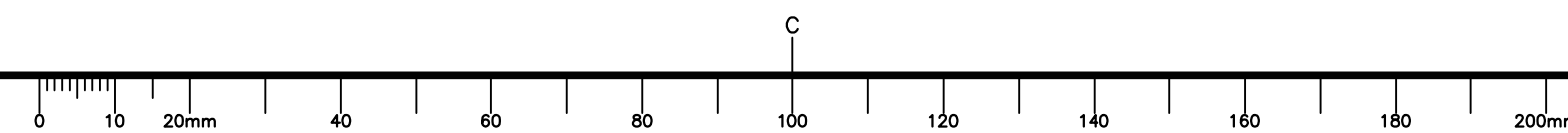

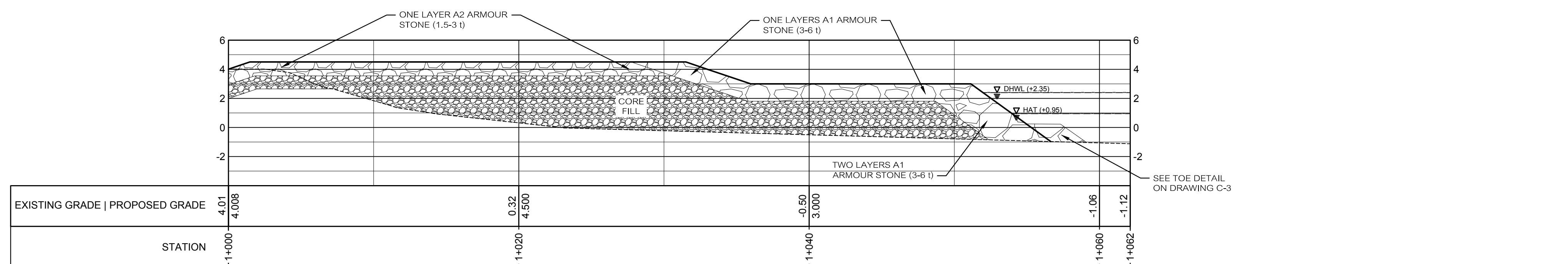
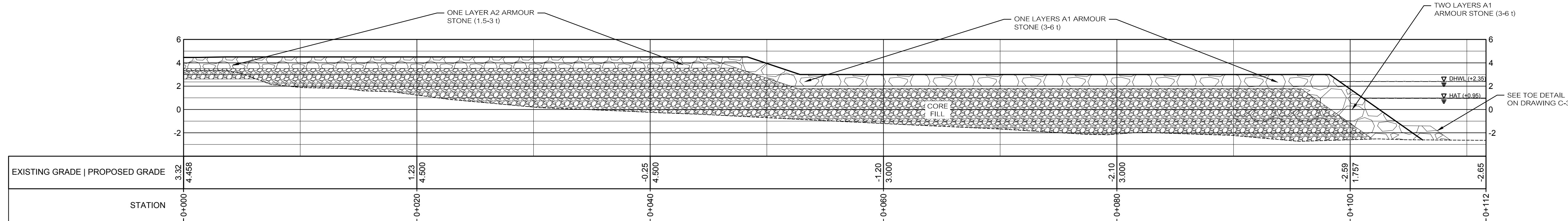
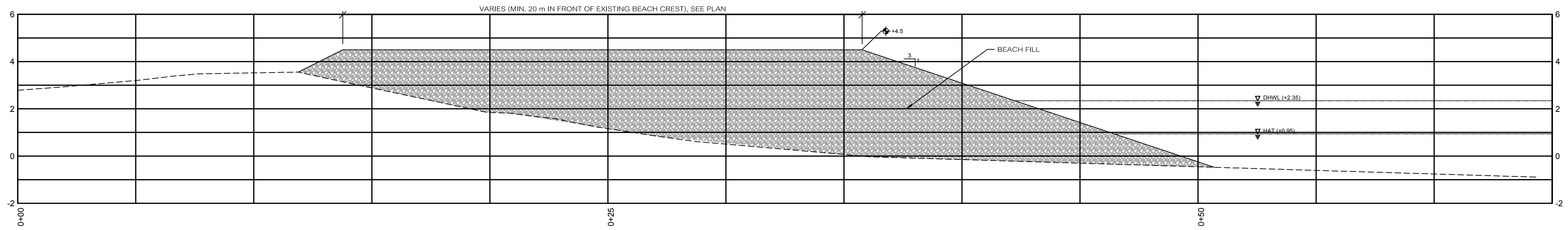
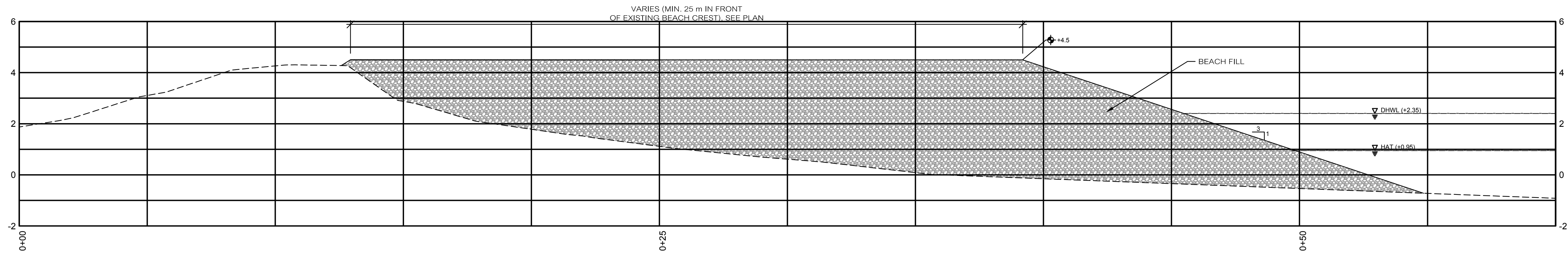

- NOTES:**
- ELEVATIONS SHOWN ARE GEODETIC CGVD28, AND ARE REFERENCED TO N.S.C.M. 201666 AT AN ELEVATION OF 13.478 m. COORDINATES REFER TO NAD83 REFERENCE SYSTEM.
 - THE OFFSET FROM CHART DATUM (CD) TO GEODETIC DATUM CGVD28 IS 0.91 M (I.E. 0.91 M CD = 0.0 M CGVD28).



revisions	ISSUED FOR TENDER	date
A	ISSUED FOR TENDER	AUG 2017
project		project

BARRIER BEACH GROYNES AND RENOURISHMENT FORTRESS OF LOUISBOURG NATIONAL HISTORIC SITE LOUISBOURG, NS

TYPICAL BEACH FILL AND GROYNES SECTIONS

designed	JJK	conçu
date	AUG 22, 2017	
drawn	JJK	dessiné
date	AUG 22, 2017	
approved	CK	approuvé
date	AUG 22, 2017	
Tender	AD	Submission
Parks Project Manager	Administrateur de projets Parks	
project number	578	no. du projet

578

C-4

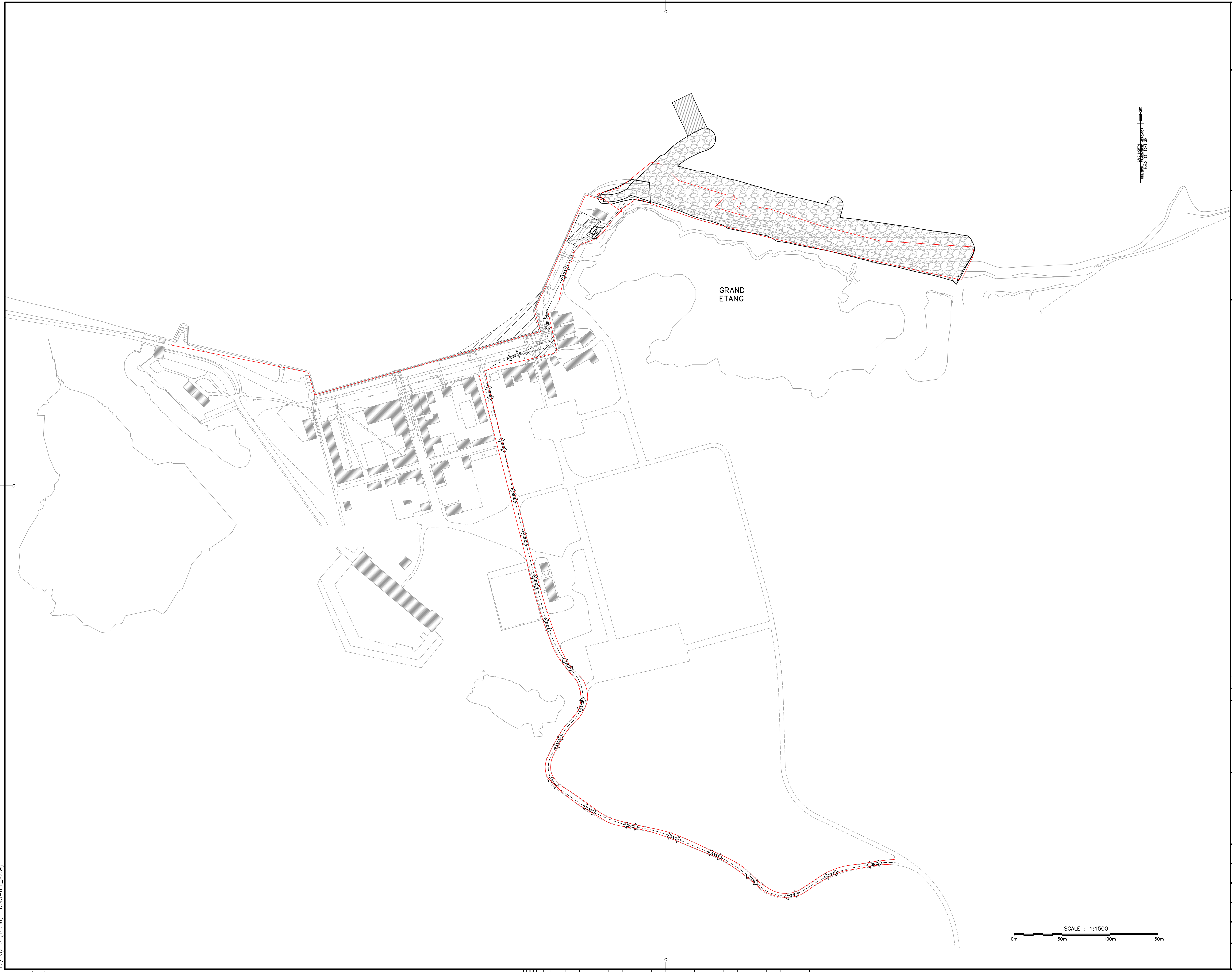

LEGEND

— CLEARED ARCHAEOLOGY AREAS

NOTE:
CONTRACTOR IS TO HAVE THE
CLEARED ARCHAEOLOGY MARKED
(SURVEY STAKES MINIMUM OF 1.2 m IN
HEIGHT WITH FLAGGING) AT 5.0 m
INTERVALS ALONG THE ROADWAY ALL
THE WAY TO THE BARRIER BEACH.

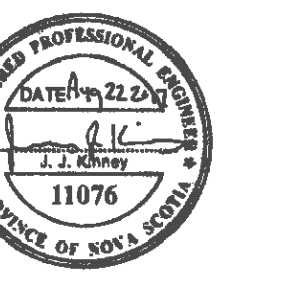

A	ISSUED FOR TENDER	AUG 2017
revisions		date

project project
**BARRIER BEACH
 GROYNES AND RENOURISHMENT
 FORTRESS OF LOUISBOURG
 NATIONAL HISTORIC SITE
 LOUISBOURG, NS**

drawing dessin
CLEARED ARCHAEOLOGY AREAS

designed	JJK	conçu
date	AUG 22, 2017	
drawn	JJK	dessiné
date	AUG 22, 2017	
approved	CK	approuvé
date	AUG 22, 2017	

Tender	Soumission	
AD	Parcs Project Manager	Administrateur de projets Parcs
project number	578	no. du projet
drawing no.	C-5	no. du dessin

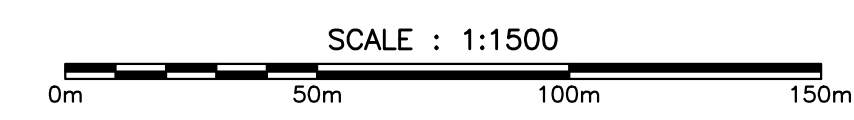

17/03/10 (10:56) 1545-6_1_A.dwg

