



RETURN BIDS TO:

RETOURNER LES SOUMISSIONS À:

Public Works and Government Services Canada
ATB Place North Tower
10025 Jasper Ave./10025 ave. Jasper
5th floor/5e étage
Edmonton
Alberta
T5J 1S6
Bid Fax: (780) 497-3510

**SOLICITATION AMENDMENT
MODIFICATION DE L'INVITATION**

The referenced document is hereby revised; unless otherwise indicated, all other terms and conditions of the Solicitation remain the same.

Ce document est par la présente révisé; sauf indication contraire, les modalités de l'invitation demeurent les mêmes.

Comments - Commentaires

**Vendor/Firm Name and Address
Raison sociale et adresse du
fournisseur/de l'entrepreneur**

Issuing Office - Bureau de distribution

Public Works and Government Services Canada
ATB Place North Tower
10025 Jasper Ave./10025 ave Jasper
5th floor/5e étage
Edmonton
Alberta
T5J 1S6

Title - Sujet Energy Retrofit, Couotts POE	
Solicitation No. - N° de l'invitation EP922-180663/A	Amendment No. - N° modif. 001
Client Reference No. - N° de référence du client CBSA-EP922-180663	Date 2017-12-06
GETS Reference No. - N° de référence de SEAG PW-\$PWU-066-11263	
File No. - N° de dossier PWU-7-40182 (066)	CCC No./N° CCC - FMS No./N° VME
Solicitation Closes - L'invitation prend fin at - à 02:00 PM on - le 2017-12-19	Time Zone Fuseau horaire Mountain Standard Time MST
F.O.B. - F.A.B. Plant-Usine: <input type="checkbox"/> Destination: <input type="checkbox"/> Other-Autre: <input type="checkbox"/>	
Address Enquiries to: - Adresser toutes questions à: Lee, Mony	Buyer Id - Id de l'acheteur pww066
Telephone No. - N° de téléphone (780) 224-6675 ()	FAX No. - N° de FAX (780) 497-3510
Destination - of Goods, Services, and Construction: Destination - des biens, services et construction:	

Instructions: See Herein

Instructions: Voir aux présentes

Delivery Required - Livraison exigée	Delivery Offered - Livraison proposée
Vendor/Firm Name and Address Raison sociale et adresse du fournisseur/de l'entrepreneur	
Telephone No. - N° de téléphone Facsimile No. - N° de télécopieur	
Name and title of person authorized to sign on behalf of Vendor/Firm (type or print) Nom et titre de la personne autorisée à signer au nom du fournisseur/ de l'entrepreneur (taper ou écrire en caractères d'imprimerie)	
Signature	Date

SOLICITATION AMENDMENT No. 001

The following questions and answers are address to the specifications for clarification purposes only.

Question 1. Anticipated start and/or completion dates?

Response: Anticipated start date can be January 15, 2018. March 31 will be the end date of the project.

Question 2. Are the new light fixtures owner supplied or contractor supplied?

Response: The lights will be contractor supplied.

Question 3. If the fixtures are contractor supplied I would like to see **cut sheets on the existing fixtures** to make sure the new fixtures are able to adapt to the space if recessed, or be able to mount on the brackets in the case of pole mounted fixtures.

Response: See attached original as-built plan. It has existing specs for the lights.

Question 4. If the contractor is supplying the fixtures is it the intent to replace the entire fixture or to retrofit the existing housing with LED components?

Response: Replace the entire fixture.

Question 5. What is the height of the pole lights? The drawings say they are 10 M poles but I am sure they are much taller than that.

Response: The poles are actually 20m high. The drawings show 10m, but will be replaced and updated to match what is standing.

Question 6. Have there been any specific fixtures specified for this job? Make/model #'s

Response: A performance spec has been provided, not a specific fixture. Contractor will submit cut sheets and shop drawings to confirm that they can be used.

All other terms and conditions of the Invitation to Tender remain unchanged.

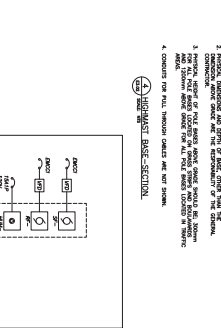
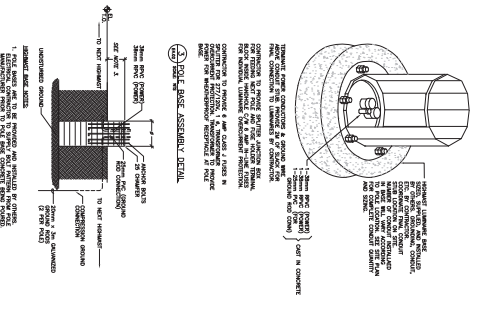
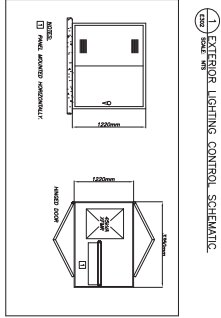
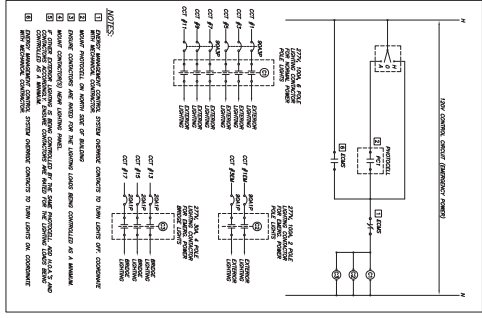

LIST OF MATERIALS FOR PANEL - LABR-1

QTY	DESCRIPTION	UNIT	QTY	DESCRIPTION	UNIT	QTY	DESCRIPTION	UNIT
1
2
3
4
5
6
7
8
9
10
11
12
13
14
15
16
17
18
19
20
21
22
23
24

LIST OF MATERIALS FOR PANEL - LABR-2

QTY	DESCRIPTION	UNIT	QTY	DESCRIPTION	UNIT	QTY	DESCRIPTION	UNIT
1
2
3
4
5
6
7
8
9
10
11
12
13
14
15
16
17
18
19
20
21
22
23
24

LIST OF MATERIALS FOR PANEL - LABR-3

QTY	DESCRIPTION	UNIT	QTY	DESCRIPTION	UNIT	QTY	DESCRIPTION	UNIT
1
2
3
4
5
6
7
8
9
10
11
12
13
14
15
16
17
18
19
20
21
22
23
24

LIST OF MATERIALS FOR PANEL - LABR-4

QTY	DESCRIPTION	UNIT	QTY	DESCRIPTION	UNIT	QTY	DESCRIPTION	UNIT
1
2
3
4
5
6
7
8
9
10
11
12
13
14
15
16
17
18
19
20
21
22
23
24

LIST OF MATERIALS FOR PANEL - LABR-5

QTY	DESCRIPTION	UNIT	QTY	DESCRIPTION	UNIT	QTY	DESCRIPTION	UNIT
1
2
3
4
5
6
7
8
9
10
11
12
13
14
15
16
17
18
19
20
21
22
23
24

Earth Tech

7000 16th Street, Suite 100
 Denver, CO 80202
 (303) 751-1000
 www.earthtech.com

US / CANADA

PROJECT TITLE: SHARED PORT OF ENTRY
 CONTRACT NUMBER: 03-0000000000000000
 CONTRACT BRIDGE NUMBER: 03-0000000000000000
 CONTRACT NUMBER: 03-0000000000000000
 CONTRACT BRIDGE NUMBER: 03-0000000000000000

GENERAL SERVICES ADMINISTRATION
 ROBERT MONROE REGION
 JOINTLY WITH
 CANADA CUSTOMS AND REVENUE AGENCY

PROPERTY OF
 CUSTOMERS
 FOR OFFICIAL USE ONLY

BUILDING TITLE: MAIN PORT BUILDING
 UNIT: MRB-AH1

DESIGN: CHAMBERLAIN DATE: MARCH 2001
 SCALE: N.T.S.
 SHEET NO.: E3.02

BIRD MANAGEMENT LIMITED

201 GUYANA AVENUE, SUITE 200
 DENVER, COLORADO 80202
 (303) 751-1000
 www.birdmanagement.com

201 GUYANA AVENUE, SUITE 200
 DENVER, COLORADO 80202
 (303) 751-1000
 www.birdmanagement.com

201 GUYANA AVENUE, SUITE 200
 DENVER, COLORADO 80202
 (303) 751-1000
 www.birdmanagement.com

US / CANADA

PROJECT TITLE: SHARED PORT OF ENTRY
 CONTRACT NUMBER: 03-0000000000000000
 CONTRACT BRIDGE NUMBER: 03-0000000000000000
 CONTRACT NUMBER: 03-0000000000000000
 CONTRACT BRIDGE NUMBER: 03-0000000000000000

GENERAL SERVICES ADMINISTRATION
 ROBERT MONROE REGION
 JOINTLY WITH
 CANADA CUSTOMS AND REVENUE AGENCY

PROPERTY OF
 CUSTOMERS
 FOR OFFICIAL USE ONLY

BUILDING TITLE: MAIN PORT BUILDING
 UNIT: MRB-AH1

DESIGN: CHAMBERLAIN DATE: MARCH 2001
 SCALE: N.T.S.
 SHEET NO.: E3.02

US / CANADA

PROJECT TITLE: SHARED PORT OF ENTRY
 CONTRACT NUMBER: 03-0000000000000000
 CONTRACT BRIDGE NUMBER: 03-0000000000000000
 CONTRACT NUMBER: 03-0000000000000000
 CONTRACT BRIDGE NUMBER: 03-0000000000000000

GENERAL SERVICES ADMINISTRATION
 ROBERT MONROE REGION
 JOINTLY WITH
 CANADA CUSTOMS AND REVENUE AGENCY

PROPERTY OF
 CUSTOMERS
 FOR OFFICIAL USE ONLY

BUILDING TITLE: MAIN PORT BUILDING
 UNIT: MRB-AH1

DESIGN: CHAMBERLAIN DATE: MARCH 2001
 SCALE: N.T.S.
 SHEET NO.: E3.02

US / CANADA

PROJECT TITLE: SHARED PORT OF ENTRY
 CONTRACT NUMBER: 03-0000000000000000
 CONTRACT BRIDGE NUMBER: 03-0000000000000000
 CONTRACT NUMBER: 03-0000000000000000
 CONTRACT BRIDGE NUMBER: 03-0000000000000000

GENERAL SERVICES ADMINISTRATION
 ROBERT MONROE REGION
 JOINTLY WITH
 CANADA CUSTOMS AND REVENUE AGENCY

PROPERTY OF
 CUSTOMERS
 FOR OFFICIAL USE ONLY

BUILDING TITLE: MAIN PORT BUILDING
 UNIT: MRB-AH1

DESIGN: CHAMBERLAIN DATE: MARCH 2001
 SCALE: N.T.S.
 SHEET NO.: E3.02

US / CANADA

PROJECT TITLE: SHARED PORT OF ENTRY
 CONTRACT NUMBER: 03-0000000000000000
 CONTRACT BRIDGE NUMBER: 03-0000000000000000
 CONTRACT NUMBER: 03-0000000000000000
 CONTRACT BRIDGE NUMBER: 03-0000000000000000

GENERAL SERVICES ADMINISTRATION
 ROBERT MONROE REGION
 JOINTLY WITH
 CANADA CUSTOMS AND REVENUE AGENCY

PROPERTY OF
 CUSTOMERS
 FOR OFFICIAL USE ONLY

BUILDING TITLE: MAIN PORT BUILDING
 UNIT: MRB-AH1

DESIGN: CHAMBERLAIN DATE: MARCH 2001
 SCALE: N.T.S.
 SHEET NO.: E3.02