

INVITATION TO TENDER

RETURN BIDS TO:

Bid Receiving / Agriculture and Agri-Food Canada

Agriculture and Agri-Food Canada
 K. W. Neatby Building
 Security Desk, Main Lobby
 960 Carling Avenue
 Ottawa, Ontario, K1A 0C6
 Attention: Gabrielle Raina Rees

TENDER TO:

Agriculture and Agri-Food Canada

We hereby offer to sell to Her Majesty the Queen in right of Canada, in accordance with the terms and conditions set out herein, referred to herein or attached hereto, the construction listed herein and on any attached sheets at the price(s) set out therefor.

Comments

Title Replacement of 40 Ton Chiller in Penthouse - Building 22	
Solicitation No. 17-1221	Date 2017-12-15
Client Reference No. CEF17 0014	
File No. 17-1221	
Solicitation Closes: Monday, January 8, 2018, at 02:00 PM, EST.	
F.O.B. <input type="radio"/> Plant <input checked="" type="radio"/> Destination <input type="radio"/> Other	
Address Enquiries to: Gabrielle Raina Rees	
Title: Senior Contracting Officer	
Email: gabrielle.rees@agr.gc.ca	
Telephone Number Ext. 613 759-6157	Fax Number 613 759-7005
Destination Agriculture and Agri-Food Canada Central Experimental Farm, Building 22 960 Carling Avenue Ottawa, Ontario, K1A 0C6	

Instructions: See Herein

Delivery Required March 30, 2018	Delivery Offered
Vendor / Firm Name and Address	
Telephone Number Ext.	Fax Number
Name and title of person authorized to sign on behalf of Vendor / Firm (type or print)	
_____ Signature	_____ Date

ISSUING OFFICE

Agriculture and Agri-Food Canada
 K. W. Neatby Building
 960 Carling Avenue
 Ottawa, Ontario, K1A 0C6



TABLE OF CONTENTS

1. Invitation to Tender
2. Appendix "A" Instructions to Bidders
3. Appendix "B" Special Instructions to Bidders
4. Appendix "C" Bid and Acceptance Form
5. Appendix "D" Minor Work - General Conditions
6. Appendix "E" Technical Specifications & Plans
7. Appendix "F" Insurance Terms

Forms

- Certificate of Insurance
- T4-A Certification
- Subcontractors
- Former Public Servant



Appendix "A"

INSTRUCTIONS TO BIDDERS



INSTRUCTIONS TO BIDDERS

IB01	Completion of Bid
IB02	Identity or Legal Capacity of the Bidder
IB03	Applicable Taxes
IB04	Tax to Be Included
IB05	Capital Development and Redevelopment Charges
IB06	Registry and Pre-qualification of Floating Plant
IB07	Listing of Subcontractors and Suppliers
IB08	Bid Security Requirements
IB09	Submission of Bid
IB10	Revision of Bid
IB11	Acceptance of Bid
IB12	Bid Costs
IB13	Compliance with Applicable Laws
IB14	Approval of Alternative Materials
IB15	Income Tax Requirement
IB16	Contingency Fees
IB17	Status of the Bidder
IB18	Integrity Provisions - Bids Over \$10,000.00
IB19	Code of Conduct for Procurement - Bid

IB01 Completion of Bid

- 1) The bid shall be:
 - (a) submitted on the BID AND ACCEPTANCE FORM provided by AAFC or on a clear and legible reproduced copy of such BID AND ACCEPTANCE FORM that must be identical in content and format to the BID AND ACCEPTANCE FORM provided by AAFC;
 - (b) based on the Bid Documents listed in the SPECIAL INSTRUCTIONS TO BIDDERS;
 - (c) correctly completed in all respects;
 - (d) signed, with an original signature, by a duly authorized representative of the Bidder; and
 - (e) accompanied by any other document or documents specified elsewhere in the solicitation where it is stipulated that said documents are to accompany the bid.
- 2) Subject to paragraph 6) of IB11, any alteration to the pre-printed or pre-typed sections of the BID AND ACCEPTANCE FORM, or any condition or qualification placed upon the bid shall be cause for disqualification. Alterations, corrections, changes or erasures made to statements or figures entered on the BID AND ACCEPTANCE FORM by the Bidder shall be initialed by the person or persons signing the bid. Initials shall be original(s). Alterations, corrections, changes or erasures that are not initialed shall be deemed void and without effect.
- 3) Unless otherwise noted elsewhere in the Bid Documents, facsimile copies of bids are not acceptable.

INSTRUCTIONS TO BIDDERS (Continued)

IB02 Identity or Legal Capacity of the Bidder

- 1) In order to confirm the authority of the person or persons signing the bid or to establish the legal capacity under which the Bidder proposes to enter into Contract, any Bidder who carries on business in other than its own personal name shall, if requested by Canada, provide satisfactory proof of:
 - (a) such signing authority; and
 - (b) the legal capacity under which it carries on business;prior to contract award. Proof of signing authority may be in the form of a certified copy of a resolution naming the signatory(ies) that is (are) authorized to sign this bid on behalf of the corporation or partnership. Proof of legal capacity may be in the form of a copy of the articles of incorporation or the registration of the business name of a sole proprietor or partnership.

IB03 Applicable Taxes

- 1) Bidders are not to include any amounts for Applicable Taxes (Goods and Services Tax (GST), Harmonized Sales Tax (HST) or Quebec Sales Tax (QST), whichever is applicable. Any amount levied in respect of Applicable Taxes shall be billed as a separate item in a progress claim submitted by the Contractor, and shall be paid to the Contractor in addition to the amount approved by Canada for work performed under the Contract. The Contractor shall be required to remit the appropriate amount to the appropriate tax authority in accordance with the applicable legislation.

IB04 Tax to Be Included

- 1) The Contractor is not entitled to use Canada's exemptions from any tax, such as provincial sales taxes, unless otherwise specified by law. The Contractor must pay applicable provincial sales tax, ancillary taxes, and any commodity tax, on taxable goods or services used or consumed in the performance of the Contract (in accordance with applicable legislation), including for material incorporated into real property.

IB05 Capital Development and Redevelopment Charges

- 1) For the purposes of GC1.5 in the General Conditions of the Contract, only fees or charges directly related to the processing and issuing of building permits shall be included. The Bidder shall not include any monies in the bid amount for special municipal development, redevelopment or other fees or charges which a municipal authority may seek as a prerequisite to the issuance of building permits.

IB06 Registry and Pre-qualification of Floating Plant

- 1) Dredges or other floating plant to be used in the performance of the Work must be of Canadian registry. For dredges or other floating plant that are not of Canadian make or manufacture, the Bidder must obtain a certificate of qualification from Industry Canada and this certificate must accompany the bid. Plant so qualified by Industry Canada may be accepted on this project.

IB07 Listing of Subcontractors and Suppliers

- 1) Notwithstanding any list of Subcontractors that the Bidder may be required to submit as part of the bid, the Bidder submitting the lowest acceptable bid shall, within 48 hours of receipt of a notice to do so, submit all information requested in the said notice including the names of Subcontractors and Suppliers for the part or parts of the Work listed. Failure to do so may result in the disqualification of its bid.

INSTRUCTIONS TO BIDDERS (Continued)

IB08 Bid Security Requirements

- 1) **NO** bid security is required for this solicitation notice.

IB09 Submission of Bid

- 1) The BID AND ACCEPTANCE FORM, duly completed, shall be enclosed and sealed in an envelope provided by the Bidder, and shall be addressed and submitted to the office designated on the Front Page of the BID AND ACCEPTANCE FORM for the receipt of bids. The bid must be received on or before the date and time set for solicitation closing.
- 2) Unless otherwise specified in the SPECIAL INSTRUCTIONS TO BIDDERS
 - (a) the bid shall be in Canadian currency;
 - (b) exchange rate fluctuation protection is not offered; and
 - (c) any request for exchange rate fluctuation protection shall not be considered.
- 3) Prior to submitting the bid, the Bidder shall ensure that the following information is clearly printed or typed on the face of the bid envelope:
 - (a) Solicitation/File Number;
 - (b) Name of Bidder;
 - (c) Return address; and
 - (d) Closing Date and Time.
- 4) Subject to paragraph 6) of IB11, failure to comply with paragraphs 1), 2) and 3) of IB09 shall render the bid liable to disqualification. Timely and correct delivery of bids is the sole responsibility of the Bidder.

IB10 Revision of Bid

- 1) A bid submitted in accordance with these instructions may be revised by letter or facsimile provided the revision is received at the office designated for the receipt of bids, on or before the date and time set for the closing of the bid. The letter or facsimile shall:
 - (a) be on the Bidder's letterhead or bear a signature that identifies the Bidder;
 - (b) for the lump sum portion of a bid, clearly identify the amount of the current revision. The total aggregate sum of all revisions submitted, including the current revision, shall be shown separately; and
 - (c) for the Price Per Unit portion of a bid, clearly identify the change(s) in the Price(s) per Unit and the specific Item(s) to which each change applies. If a revision is to be applied to a specific Item that was previously amended then, in addition to the amount of the current revision, the total aggregate sum of all revisions submitted, including the current revision, for that Item shall be shown separately.
- 2) A letter or facsimile submitted to confirm an earlier revision shall be clearly identified as "CONFIRMATION ONLY" for each contemplated change.
- 3) Failure to comply with any of the above provisions shall result in the rejection of the non-compliant revision(s) only. The bid shall be evaluated based on the original bid submitted and all other compliant revision(s).

IB11 Acceptance of Bid

- 1) Canada may accept any bid, whether it is the lowest or not, or may reject any or all bids.
- 2) Without limiting the generality of paragraph 1) of IB11, Canada may reject a bid if any of the following circumstances is present:

INSTRUCTIONS TO BIDDERS (Continued)

- (a) the Bidder, or any employee or subcontractor included as part of the bid, has been convicted under section 121 ("Frauds on the government" & "Contractor subscribing to election fund"), 124 ("Selling or purchasing office"), 380 ("Fraud committed against Her Majesty") or 418 ("Selling defective stores to Her Majesty") of the Criminal Code of Canada; or under paragraph 80(1)(d) ("False entry, certificate of return"), subsection 80(2) ("Fraud against Her Majesty") or Section 154.01 ("Fraud against Her Majesty") of the *Financial Administration Act*;
 - (b) the Bidder's bidding privileges are suspended or are in the process of being suspended;
 - (c) the bidding privileges of any employee or subcontractor included as part of the bid are suspended or are in the process of being suspended, which suspension or pending suspension would render that employee or subcontractor ineligible to bid on the Work, or the portion of the Work the employee or subcontractor is to perform;
 - (d) with respect to current or prior transactions with Canada
 - (i) the Bidder is bankrupt or if, for whatever reason, its activities are rendered inoperable for an extended period;
 - (ii) evidence, satisfactory to Canada, of fraud, bribery, fraudulent misrepresentation or failure to comply with any law protecting individuals against any manner of discrimination, has been received with respect to the Bidder, any of its employees or any subcontractor included as part of its bid;
 - (iii) Canada has exercised, or intends to exercise, the contractual remedy of taking the work out of the contractor's hands with respect to a contract with the Bidder, any of its employees or any subcontractor included as part of its bid; or
 - (iv) Canada determines that the Bidder's performance on other contracts is sufficiently poor to jeopardize the successful completion of the requirement being bid on.
- 3) In assessing the Bidder's performance on other contracts pursuant to subparagraph 2)(d)(iv) of IB11, Canada may consider, but not be limited to, such matters as:
- (a) the quality of workmanship in performing the Work;
 - (b) the timeliness of completion of the Work;
 - (c) the overall management of the Work and its effect on the level of effort demanded of the department and its representative; and
 - (d) the completeness and effectiveness of the Contractor's safety program during the performance of the Work.
- 4) Without limiting the generality of paragraphs 1), 2) and 3) of IB11, Canada may reject any bid based on an unfavourable assessment of the:
- (a) adequacy of the bid price to permit the work to be carried out and, in the case of a bid providing prices per unit or a combination of lump sum and prices per unit, whether each such price reasonably reflects the cost of performing the part of the work to which that price applies;
 - (b) Bidder's ability to provide the necessary management structure, skilled personnel, experience and equipment to perform competently the work under the Contract; and
 - (c) Bidder's performance on other contracts.
- 5) If Canada intends to reject a bid pursuant to a provision of paragraphs 1), 2), 3) or 4) of IB11, other than subparagraph 2)(b) of IB11, Canada shall so inform the Bidder and provide the Bidder ten (10) days within which to make representations, prior to making a final decision on the bid rejection.
- 6) Canada may waive informalities and minor irregularities in bids received if Canada determines that the variation of the bid from the exact requirements set out in the Bid Documents can be corrected or waived without being prejudicial to other Bidders.

INSTRUCTIONS TO BIDDERS (Continued)

IB12 Bid Costs

- 1) No payment will be made for costs incurred in the preparation and submission of a bid in response to the bid solicitation. Costs associated with preparing and submitting a bid, as well as any costs incurred by the Bidder associated with the evaluation of the bid, are the sole responsibility of the Bidder.

IB13 Compliance with Applicable Laws

- 1) By submission of a bid, the Bidder certifies that the Bidder has the legal capacity to enter into a contract and is in possession of all valid licences, permits, registrations, certificates, declarations, filings, or other authorizations necessary to comply with all federal, provincial and municipal laws and regulations applicable to the submission of the bid and entry into any ensuing contract for the performance of the work.
- 2) For the purpose of validating the certification in paragraph 1) of IB13, a Bidder shall, if requested, provide a copy of every valid licence, permit, registration, certificate, declaration, filing or other authorization listed in the request, and shall provide such documentation within the time limit(s) set out in the said request.
- 3) Failure to comply with the requirements of paragraph 2) of IB13 shall result in disqualification of the bid.

IB14 Approval of Alternative Materials

- 1) When materials are specified by trade names or trademarks, or by manufacturers' or suppliers' names, the bid shall be based on use of the named materials. During the bid period, alternative materials may be considered provided full technical data is received in writing by the Contracting Officer at least 10 calendar days prior to the bid closing date.

IB15 Income Tax Requirement

- 1) Payments made under applicable contracts must be reported by Canada for taxation purposes. To comply with this requirement, the successful bidder shall provide to Canada immediately upon award: its legal name; address; and Revenue Canada identifier (SIN, BN, GST/HST, T2N number) as is applicable.

IB16 Contingency Fees

- 1) The Bidder declares that the Bidder has not, directly or indirectly, paid or agreed to pay, and will not, directly or indirectly, pay a contingency fee to any individual for the solicitation, negotiation or obtaining of the contract if the payment of the fee would require the individual to file a return under section 5 of the *Lobbying Act*.

IB17 Status of the Bidder

- 1) The Bidder declares that the Bidder has not been convicted of an offence, other than an offence for which a pardon has been granted, under section 121, 124 or 418 of the *Criminal Code*.

IB18 Integrity Provisions - Bids Over \$10,000.00

INSTRUCTIONS TO BIDDERS (Continued)

- 1) Ineligibility and Suspension Policy (the "Policy"), and all related Directives, are incorporated by reference into, and form a binding part of the procurement process. The Supplier must comply with the Policy and Directives, which can be found at [Ineligibility and Suspension Policy](#).
- 2) Under the Policy, charges and convictions of certain offences against a Supplier, its affiliates or first tier subcontractors, and other circumstances, will or may result in a determination by Public Works and Government Services Canada (PWGSC) that the Supplier is ineligible to enter, or is suspended from entering into a contract with Canada. The list of ineligible and suspended Suppliers is contained in PWGSC's Integrity Database. The Policy describes how enquiries can be made regarding the ineligibility or suspension of Suppliers.
- 3) In addition to all other information required in the procurement process, the Supplier must provide the following:
 - a. by the time stated in the Policy, all information required by the Policy described under the heading "Information to be Provided when Bidding, Contracting or Entering into a Real Property Agreement"; and
 - b. with its bid / quote / proposal, a complete list of all foreign criminal charges and convictions pertaining to itself, its affiliates and its proposed first tier subcontractors that, to the best of its knowledge and belief, may be similar to one of the listed offences in the Policy. The list of foreign criminal charges and convictions must be submitted using an Integrity Declaration Form, which can be found at [Declaration form for procurement](#).
- 4) Subject to subsection 5, by submitting a bid / quote / proposal in response a request by AAFC, the Supplier certifies that:
 - a. it has read and understands the [Ineligibility and Suspension Policy](#);
 - b. it understands that certain domestic and foreign criminal charges and convictions, and other circumstances, as described in the Policy, will or may result in a determination of ineligibility or suspension under the Policy;
 - c. it is aware that Canada may request additional information, certifications, and validations from the Supplier or a third party for purposes of making a determination of ineligibility or suspension;
 - d. it has provided with its bid / quote / proposal a complete list of all foreign criminal charges and convictions pertaining to itself, its affiliates and its proposed first tier subcontractors that, to the best of its knowledge and belief, may be similar to one of the listed offences in the Policy;
 - e. none of the domestic criminal offences, and other circumstances, described in the Policy that will or may result in a determination of ineligibility or suspension, apply to it, its affiliates and its proposed first tier subcontractors; and
 - f. it is not aware of a determination of ineligibility or suspension issued by PWGSC that applies to it.
- 5) Where a Supplier is unable to provide any of the certifications required by subsection 4, it must submit with its bid/ quote / proposal a completed Integrity Declaration Form, which can be found at [Declaration form for procurement](#).
- 6) Canada will declare non-responsive any bid / quote / proposal in respect of which the information requested is incomplete or inaccurate, or in respect of which the information contained in a certification or declaration is found by Canada to be false or misleading in any respect. If Canada

INSTRUCTIONS TO BIDDERS (Continued)

establishes after award of the Contract that the Supplier provided a false or misleading certification or declaration, Canada may terminate the Contract for default. Pursuant to the Policy, Canada may also determine the Supplier to be ineligible for award of a contract for providing a false or misleading certification or declaration.

Ineligibility and Suspension Policy - <http://www.tpsgc-pwgsc.gc.ca/ci-if/politique-policy-eng.html>

Declaration form for procurement - <http://www.tpsgc-pwgsc.gc.ca/ci-if/declaration-eng.html>

IB19 Code of Conduct for Procurement - Bid

- 1) The Code of Conduct for Procurement provides that Bidders must respond to bid solicitations in an honest, fair and comprehensive manner, accurately reflect their capacity to satisfy the requirements set out in the bid solicitation and resulting contract, submit bids and enter into contracts only if they will fulfill all obligations of the Contract. By submitting a bid, the Bidder is certifying that it is complying with the Code of Conduct for Procurement. Failure to comply with the Code of Conduct for Procurement may render the bid non-responsive.



Appendix "B"

SPECIAL INSTRUCTIONS TO BIDDERS

SPECIAL INSTRUCTIONS TO BIDDERS

- SI01 Bid Documents
- SI02 Enquiries during the Solicitation Period
- SI03 Mandatory Site Visit
- SI04 Revision of Bid
- SI05 Bid Results
- SI06 Bid Validity Period
- SI07 Construction Documents
- SI08 Personnel Security Requirements
- SI09 Integrity Provisions - Declaration of Convicted Offences

SI01 BID DOCUMENTS

- 1) The following are the bid documents:
 - (a) SPECIAL INSTRUCTIONS TO BIDDERS;
 - (b) INSTRUCTIONS TO BIDDERS - Form A5319-E; and,
 - (c) BID AND ACCEPTANCE FORM - Form A5312-E and any attachments thereto.

Canada reserves the right to revise or amend the Bid Documents prior to the date set for opening bids. Such revisions or amendments, if any, will be announced by an addendum or addenda to the documents.

Submission of a bid constitutes acknowledgement that the Bidder has read and agrees to be bound by these documents.

SI02 ENQUIRIES DURING THE SOLICITATION PERIOD

- 1) Enquiries regarding this bid must be submitted in writing to the Contracting Officer. The Contracting Officer for the purpose of this bid is:

Gabrielle Raina Rees
Agriculture and Agri-Food Canada
960 Carling Avenue
Ottawa, Ontario, K1A 0C6

Email: gabrielle.rees@agr.gc.ca
Telephone: (613) 759-6157
- 2) Except for the approval of alternative materials as described in IB14 of the INSTRUCTIONS TO BIDDERS, enquiries should be received no later than five (5) calendar days prior to the date set for solicitation closing to allow sufficient time to provide a response. Enquiries received after that time may not result in an answer being provided.
- 3) To ensure consistency and quality of the information provided to Bidders, the Contracting Officer shall examine the content of the enquiry and shall decide whether or not to issue an amendment.
- 4) All enquiries and other communications related to this bid sent throughout the solicitation period are to be directed ONLY to the Contracting Officer. Non-compliance with this requirement during the solicitation period can, for that reason alone, result in disqualification of a bid.

SPECIAL INSTRUCTIONS TO BIDDERS (Continued)

SI03 MANDATORY SITE VISIT

- 1) Before submitting their bid, the Contractor shall examine the jobsite, construction and storage areas, compare drawings and specifications with existing conditions, and fully satisfy themselves as to all data and matters required for the completion of the contract.
- 2) There will be a site visit on Wednesday, December, 20, 2017 at 10:00 AM PM EST.

Interested bidders are to meet at:

Agriculture and Agri-Food Canada
Central Experimental Farm
K. W. Neatby Building, Security Desk, Main Lobby
960 Carling Avenue
Ottawa, Ontario, K1A 0C6
Attention: Tom Pucci

The site visit for this project is MANDATORY. The representative of the bidder will be required to sign the Site Visit Attendance Sheet at the site visit. Bids submitted by Bidders who have not signed the attendance sheet will not be accepted.

SI04 REVISION OF BID

- 1) A bid may be revised by letter or facsimile in accordance with IB10 of the INSTRUCTIONS TO BIDDERS. The facsimile number for receipt of revisions is: 613 759-7005.

SI05 BID RESULTS

- 1) Following bid closing, bid results may be obtained from the bid receiving office by email at gabriel.e.rees@agr.gc.ca.

SI06 BID VALIDITY PERIOD

- 1) Canada reserves the right to seek an extension to the bid validity period prescribed in Clause 4 of the BID AND ACCEPTANCE FORM. Upon notification in writing from Canada, Bidders shall have the option to either accept or reject the proposed extension.

SI07 CONSTRUCTION DOCUMENTS

- 1) The successful contractor will be provided with one paper copy of the sealed and signed drawings, the specifications and the amendments upon acceptance of the offer. Additional copies, up to a maximum of zero (0), will be provided free of charge upon request by the Contractor. Obtaining more copies shall be the responsibility of the Contractor including costs.

SPECIAL INSTRUCTIONS TO BIDDERS (Continued)

SI08 PERSONNEL SECURITY REQUIREMENTS

1) The successful Bidder's personnel, as well as any subcontractor and its personnel, who are required to perform any part of the work pursuant to the subsequent contract, must meet the following contract security requirements:

- Personnel who are required to perform any part of the work must EACH hold a valid personnel security screening at the level of RELIABILITY STATUS, granted or approved by Agriculture and Agri-Food Canada. Until the security screening of the personnel has been completed satisfactorily by Agriculture and Agri-Food Canada, the Contractor/Subcontractor personnel MAY NOT perform contract work. Each of the proposed staff must complete "Security Clearance Form" (TBS 330-23E) upon request from Canada.

Cost for security screening - The program does not charge for its screening services. However, your organization must cover any costs needed to comply with the security requirements of a government contract. For example, these costs might include the purchase of file cabinets to safely store Secret documents. They might also include the fees charged by third-party service providers to take and submit fingerprints electronically.

SI09 INTEGRITY PROVISIONS – DECLARATION OF CONVICTED OFFENCES

As applicable, pursuant to IB18 of the Declaration of Convicted Offences, paragraph 10 (copied below) of the General Instruction AAFC / AAC5319, the Bidder must provide with its bid, a completed *Declaration Form*, to be given further consideration in the procurement process.

Declaration of Convicted Offences

Where a Bidder or its Affiliate is unable to certify that it has not been convicted of any of the offences referenced under the Canadian Offences Resulting in Legal Incapacity, the Canadian Offences and the Foreign Offences subsections, the Bidder must provide with its bid the completed [Declaration Form](#), to be given further consideration in the procurement process.



Appendix "C"

BID AND ACCEPTANCE FORM

BID AND ACCEPTANCE FORM
CONSTRUCTION CONTRACT - MINOR WORKS

Solicitation / File Number: 17-1221
Project: Replacement of 40 Ton Chiller in Penthouse - Building 22
Contract:

MAIL OR DELIVER BID TO:
Agriculture and Agri-Food Canada
K.W. Neatby Building, Security Desk, Main Lobby
960 Carling Avenue
Ottawa, Ontario, K1A 0C6
Attention: Gabrielle Raina Rees

BID CLOSING TIME:
Monday, January 08, 2018
Day of week Month Day Year
at 02:00 AM PM local time.

DESCRIPTION OF WORKS:
Replacement of 40 Ton Chiller in Penthouse of Building 22 located at the Central Experimental Farm in Ottawa, Ontario.

INSTRUCTIONS TO BIDDERS:
Bidders shall be governed by the following instructions:
- SPECIAL INSTRUCTIONS TO BIDDERS - Form AAFC / AAC5318-E
- INSTRUCTIONS TO BIDDERS - Form AAFC / AAC5319-E

The following additional documents form an attachment to this BID AND ACCEPTANCE FORM:
 List of Subcontractors

OFFER AND AGREEMENT

1. The undersigned bidder (hereinafter called the "Contractor") hereby offers to Her Majesty the Queen in right of Canada, as represented by the Minister of Agriculture and Agri-Food (hereinafter called "Canada"), to furnish all necessary labour, plant and material and to execute and complete in a satisfactory and workmanlike manner all the work required under this contract for the consideration of the unit or lump sum price or prices set forth in the Price Table below. The Contractor agrees that these prices include all applicable provincial sales taxes, ancillary taxes and any commodity tax. Note: Do not include Applicable Taxes (GST/HST/QST) as defined in the General Conditions in price(s).

PRICE TABLE					
Item	Class of Labour, Plant, or Material	Unit of Measurement	Estimated Total Quantity	Price Per Unit	Estimated Total Price
01		LUMP SUM			
NOTE: Both price per unit and estimated total price must be filled in for each item in the Price Table. All estimated total prices will be subject to verification by Canada. In case of variation between the price per unit and the estimated total price, the price per unit will be considered to be the price bid.				Total Bid	

- The Contractor shall perform and complete the Work on or before 2018-03-30.
- The Contractor hereby acknowledges receipt of the following addenda to the bid documents (give number and date of each):
Addenda numbers: _____ Dates: _____
- The Contractor agrees that this offer: supersedes and cancels all communications, negotiations, and agreements relating to the work other than contained in this completed bid or any amendment incorporated by mutual agreement between the Contractor and Canada before acceptance of this Offer and Agreement; is irrevocable for 30 days after the Bid Closing Time shown hereon.
- The Contractor agrees, that the complete bid together with and subject to all the provisions contained herein shall, when accepted and executed on behalf of Canada, constitute a binding contract between the Contractor and Canada.
- The following additional documents form an attachment to a binding contract:
 - GENERAL CONDITIONS FOR MINOR WORKS - Form AAFC / AAC5316-E
 - Specifications
 - Insurance Terms

BID AND ACCEPTANCE FORM (Continued)

CONTRACTOR'S FULL BUSINESS NAME (Please print or type)

--

CONTRACTOR'S BUSINESS ADDRESS (for all purposes of or incidental to the contract)

Unit/Suite/Apt.	Street number	Number suffix	Street name	Street type	Street direction	
PO Box or Route Number		Municipality (City, Town, etc.)			Province	Postal code
Telephone number	Ext.	Facsimile number	E-mail (optional)		GST/HST number	

Attested to and Delivered on Behalf of the Contractor this _____ day of _____, _____.
MonthYear

CONTRACTOR'S or, where applicable, SIGNING OFFICER'S SIGNATURE(S)	TITLE(S)	In the presence of: WITNESS SIGNATURE(S)

NOTE: Corporate Firms shall affix their Corporate Seal if applicable.

(FOR DEPARTMENTAL USE ONLY)

Accepted and Executed on Behalf of Canada this _____ day of _____, _____.
MonthYear

SIGNATURE	TITLE	In the presence of: WITNESS SIGNATURE

Bid opened in _____ on _____, _____ at _____ AM PM local time.
LocationDay of weekMonthDayYear

in the presence of _____

BID AND ACCEPTANCE FORM (Continued)

INTEGRITY PROVISIONS - LIST OF NAMES
(complete if your bid exceeds \$10,000.00)

If the required list of names has not been received by the time the evaluation of bids is completed, Canada will inform the Bidder of a time frame within which to provide the information. Failure to provide the names within the time frame specified will render the bid non-responsive. Providing the required names is a mandatory requirement for contract award.

Bidders who are incorporated, including those bidding as a joint venture, must provide a complete list of names of all individuals who are currently directors of the Bidder.

Bidders bidding as sole proprietorship, as well as those bidding as a joint venture, must provide the name of the owner(s).

Bidders bidding as societies, firms or partnerships do not need to provide lists of names.



Appendix "D"

MINOR WORK - GENERAL CONDITIONS



TABLE OF CONTENTS GENERAL CONDITIONS FOR MINOR WORKS

GC 1	GENERAL PROVISIONS
GC 1.1	Definition
GC 1.2	Contract Documents
GC 1.3	Assignment
GC 1.4	Subcontracting
GC 1.5	Laws, Permits and Taxes
GC 1.6	Former Public Office Holders
GC 1.7	Status of the Contractor
GC 1.8	Contingency Fees
GC 1.9	Disclosure of Basic Information
GC 1.10	Integrity Provisions - Contracts over \$10,000.00
GC 1.11	Code of Conduct for Procurement - Contracts over \$10,000.00
GC 2	ADMINISTRATION OF THE CONTRACT
GC 2.1	Departmental Representative's Rights and Obligations
GC 2.2	Contractor's Superintendent and Workers
GC 2.3	Records to be Kept by the Contractor
GC 2.4	Notices
GC 3	EXECUTION OF THE WORK
GC 3.1	Material, Plant and Real Property Become the Property of Canada
GC 3.2	Cooperation With Other Contractors
GC 3.3	Use of the Work and Cleanup of Site
GC 3.4	Warranty and Rectification of Defects
GC 4	PROTECTION, HEALTH AND SAFETY
GC 4.1	Material, Plant and Real Property Supplied by Canada
GC 4.2	Construction Safety
GC 5	TERMS OF PAYMENT
GC 5.1	Definitions
GC 5.2	Payment - General Provisions
GC 5.3	Progress Payments
GC 5.4	Interest on Overdue Accounts
GC 5.5	Payment in the Event of Termination
GC 5.6	Final Completion
GC 5.7	Determination of Price
GC 5.8	Claims Against and Obligations of the Contractor or Subcontractor
GC 6	CHANGES IN THE WORK
GC 6.1	Changes in the Work
GC 6.2	Changes in Subsurface Conditions and Delays by Canada
GC 6.3	Extension of Time
GC 7	DEFAULT, SUSPENSION OR TERMINATION OF CONTRACT
GC 7.1	Taking the Work Out of the Contractor's Hands
GC 7.2	Effect of Taking the Work Out of the Contractor's Hands
GC 7.3	Suspension of the Contract
GC 7.4	Termination of the Contract
GC 8	DISPUTE RESOLUTION
GC 9	INDEMNIFICATION AND INSURANCE
GC 9.1	Indemnification
GC 9.2	Insurance Contracts
GC 9.3	Insurance Proceeds

GENERAL CONDITIONS FOR MINOR WORKS

GC 1 GENERAL PROVISIONS

GC 1.1 Definition

- "Applicable Taxes" means the Goods and Services Tax (GST), the Harmonized Sales Tax (HST), and any provincial tax, by law, payable by Canada such as, the Quebec Sales Tax (QST) as of April 1, 2013.
- "Canada", "Her Majesty" means Her Majesty, the Queen in right of Canada;
- "Contract" means the contract documents referred to as such therein and every other document specified or referred to in any of them as forming part of the Contract, all as amended by agreement of the parties;
- "Contractor" means a person, with whom Canada enters into a Contract to do the Work;
 - "Departmental Representative" means the person designated in the Contract, or by written notice to the Contractor, to act as the Departmental Representative for the purposes of the Contract, and includes a person, designated and authorized in writing by the Departmental Representative to the Contractor;
- "Material" includes all commodities, articles, machinery, equipment, fixtures and things required to be furnished in accordance with the Contract for incorporation into the Work;
- "Person" includes, unless there is an express stipulation in the Contract to the contrary, any partnership, proprietorship, firm, joint venture, consortium or corporation;
- "Plant" includes all tools, implements, machinery, vehicles, structures, equipment, articles and things that are necessary for the performance of the Contract, other than Material and those tools customarily provided by a trades person in practicing a trade;
- "Work" means everything that is necessary to be done, furnished or delivered by the Contractor to perform the Contract in accordance with the Contract Documents;

GC 1.2 Contract Documents

1. In interpreting the Contract, in the event of discrepancies or conflicts between anything in the Drawings and Specifications or Scope of Work and the General Conditions, the General Conditions govern.
2. In interpreting the Drawings and Specifications, in the event of discrepancies or conflicts between:
 - (a) the Drawings and Specifications, the Specifications govern;
 - (b) the Drawings, the Drawings with the largest scale govern; and
 - (c) figured dimensions and scaled dimensions, the figured dimensions govern.

GC 1.3 Assignment

1. This Contract shall not be assigned without the written consent of Canada.

GC 1.4 Subcontracting

1. The Contractor shall:
 - (a) not subcontract the whole or any part of the Work without the written consent of the Departmental Representative except for subcontracts specified in the Contract; and
 - (b) ensure that all subcontracts entered into at any tier shall incorporate all the terms and conditions of the Contract that can reasonably be applied thereto.

GENERAL CONDITIONS FOR MINOR WORKS (Continued)

GC 1.5 Laws, Permits and Taxes

1. The Contractor shall comply with all legislative and regulatory provisions whether federal, provincial, territorial or municipal applicable to the performance of the Work and shall require compliance therewith by all of its subcontractors and suppliers at any tier as if the Work were being performed for an owner other than Canada.
2. Unless otherwise provided for in the Contract, the Contractor shall obtain all permits and hold all certificates and licenses required for the performance of the Work.
3. Applicable Taxes will be paid by Canada at time when a progress payment is being made. It is the sole responsibility of the Contractor to charge Applicable Taxes at the correct rate in accordance with applicable legislation. The Contractor agrees to remit to appropriate tax authorities any amounts of Applicable Taxes paid or due.
4. The Contractor is not entitled to use Canada's exemptions from any tax, such as provincial sales taxes, unless otherwise specified by law. The Contractor must pay applicable provincial sales tax, ancillary taxes, and any commodity tax, on taxable goods or services used or consumed in the performance of the Contract (in accordance with applicable legislation), including for material incorporated into real property.

GC 1.6 Former Public Office Holders

1. No former public office holder who is not in compliance with the post-employment provisions of the Conflict of Interest and Post-Employment Code for Public Office Holders shall derive a direct benefit from the Contract.

GC 1.7 Status of the Contractor

1. The Contractor is engaged as an independent Contractor for the sole purpose of performing the Work. Neither the Contractor nor any of its personnel is engaged as an employee, servant or agent of Canada. The Contractor is responsible for all deductions and remittances required by law in relation to its employees including those required for Canada or Quebec Pension Plans, employment insurance, workers' compensation, and income tax.
2. The Contractor declares that the Contractor has not been convicted of an offence, other than an offence for which a pardon has been granted, under section 121, 124 or 418 of the Criminal Code.

GC 1.8 Contingency Fees

1. The Contractor declares that the Contractor has not, directly or indirectly, paid or agreed to pay, and will not, directly or indirectly, pay a contingency fee to any individual for the solicitation, negotiation or obtaining of the contract if the payment of the fee would require the individual to file a return under section 5 of the *Lobbying Act*.

GC 1.9 Disclosure of Basic Information

1. The Contractor consents, in the case of a contract that has a value in excess of \$10,000, to the public disclosure of basic information, other than information described in any of paragraphs 20(1)(a) to (d) of the Access to Information Act, relating to the contract.

GENERAL CONDITIONS FOR MINOR WORKS (Continued)

GC 1.10 Integrity Provisions - Contracts over \$10,000.00

- 1) The Ineligibility and Suspension Policy (the "Policy") and all related Directives are incorporated into, and form a binding part of the Contract. The Contractor must comply with the provisions of the Policy and Directives, which can be found on Public Works and Government Services Canada's website at Ineligibility and Suspension Policy. (<http://www.tpsgc-pwgsc.gc.ca/ci-if/politique-policy-eng.html>).

GC 1.11 Code of Conduct for Procurement - Contracts Over \$10,000.00

- 1) The Contractor agrees to comply with the Code of Conduct (<http://www.tpsgc-pwgsc.gc.ca/app-acq/cndt-cndct/contexte-context-eng.html>) for Procurement and to be bound by its terms for the period of the Contract.

GC 2 ADMINISTRATION OF THE CONTRACT

GC 2.1 Departmental Representative's Rights and Obligations

1. The Departmental Representative shall:
 - (a) have access to the Work at all times;
 - (b) decide questions regarding what has been done or what the Contractor is required to do;
 - (c) decide questions regarding the acceptability of the quality or quantity of any Labour, Plant or Material used or consumed in the execution of the Work; and
 - (d) decide questions regarding the timing and scheduling of the Work.

GC 2.2 Contractor's Superintendent and Workers

1. The Contractor shall keep a competent superintendent and capable and skilled workers on the site of the Work at all times during the progress of the Work. If, in the opinion of the Departmental Representative, the superintendent or the workers are deemed to be unacceptable because of incompetence, improper conduct or security risk, they shall be removed from the site of the Work and replaced forthwith.

GC 2.3 Records to be Kept by the Contractor

1. The Contractor shall maintain and keep intact complete records relating to the Work together with all tender calls, quotations, contracts, correspondence, invoices and any payment of fees or other compensation for the solicitation, negotiating or obtaining of the contract until the expiration of two (2) years after the date that a Certificate of Completion is issued or the final invoice is paid if no Certificate of Completion is issued. The Contractor shall, upon request from the Departmental Representative, make said records available for copy, audit or inspection to any person(s) acting on behalf of Canada.
2. The Contractor shall cause all Subcontractors, and all other Persons or entities directly or indirectly involved with the Work, to comply with the requirements of GC 2.3.1.

GC 2.4 Notices

1. Any notice shall be in writing and may be delivered by hand, by courier, by registered or regular mail, or by facsimile or other electronic means that provides a paper record of the text of the notice. The notice shall be addressed to the party for whom it is intended at the address in the Contract or at the last address from which the sender has received notice in accordance with this

GENERAL CONDITIONS FOR MINOR WORKS (Continued)

section. Any notice shall be deemed to be effective on the day it is received at that address or four (4) days after being sent, whichever is the earlier.

GC 3 EXECUTION OF THE WORK

GC 3.1 Material, Plant, and Real Property Become the Property of Canada

1. All Material and Plant used or consumed for the purposes of the Work shall be the property of Canada. The Material and Plant shall be used only for the purposes of the Work, and shall not be removed from the site of the Work until so approved by the Departmental Representative.
2. The Contractor shall be liable for all loss or damage to Material or Plant that is the property of Canada by virtue of this section.

GC 3.2 Cooperation with Other Contractors

1. The Contractor shall cooperate fully with other contractors or workers sent onto the site of the Work by the Departmental Representative.
2. If, at the time the Contract was executed: the Contractor could not have reasonably foreseen the sending of other contractors or workers onto the site of the Work; and, the Contractor incurs extra costs in complying with GC 3.2.1; and, the Contractor gives written notice of claim for the extra costs within ten (10) days from the date upon which the other contractors or workers were sent onto the site of the Work; then, Canada shall pay an additional amount to the Contractor, calculated pursuant to GC 5.7.

GC 3.3 Use of the Work and Cleanup of Site

1. The Contractor shall maintain the site of the Work in a tidy condition and free from the accumulation of waste material throughout the duration of the Contract.
2. Before the Departmental Representative issues the Certificate of Completion or approves payment of the final invoice, the Contractor shall remove all materials, tools, construction machinery, equipment, waste products and debris from the site of the Work.
3. Where the Work affects occupied portions of a building, the Contractor shall ensure continuity of all building services and shall ensure safe access for all persons requiring access to said building.

GC 3.4 Warranty and Rectification of Defects

1. Without restricting any warranty or guarantee implied or imposed by law or any extended warranty specified in the Contract, the Contractor shall, upon notice from the Departmental Representative and at its own expense, rectify all defects which appear in the Work within twelve (12) months from the date of issuance of the Certificate of Completion pursuant to GC 5.6.1, or from the date of the negotiable instrument issued as final payment if a Certificate of Completion is not issued, whichever is applicable.
2. The notice referred to in GC 3.4.1 shall be in writing and shall include the number of days within which the defect or fault is to be rectified.
3. The Contractor shall transfer and assign, to Canada, any subcontractor, manufacturer or supplier extended warranties or guarantees implied or imposed by law or contained in the contract documents covering periods beyond the twelve (12) months stipulated above. Extended

GENERAL CONDITIONS FOR MINOR WORKS (Continued)

warranties or guarantees referred to herein shall not extend the twelve (12) month period whereby the Contractor must rectify and make good any defect or fault that appears in the work or comes to the attention of Canada.

GC 4 PROTECTION, HEALTH AND SAFETY

GC 4.1 Material, Plant and Real Property Supplied by Canada

1. The Contractor, having care, custody and control of the Work and its site, shall be responsible for any loss or damage, excluding reasonable wear and tear, to any property of Canada arising out of the performance of the Work whether or not such loss arises from causes beyond the Contractor's control.

GC 4.2 Construction Safety

1. The Contractor shall be responsible for the health and safety of all persons granted access to the site of the Work and for initiating, maintaining and supervising all safety inspections, precautions and programs in connection with the performance of the Work in accordance with the health and safety legislation in force in the Province where the Work is being performed.

GC 5 TERMS OF PAYMENT

GC 5.1 Definitions

For the purposes of this section:

- Payment Period means a period of thirty (30) days or such other longer period as may be agreed between the Contractor and the Departmental Representative.
- An amount is Due and Payable when it is due and payable by Canada to the Contractor in accordance with the terms of the Contract.
- An amount is Overdue when it remains unpaid after the day upon which it is due and payable.
- Date of Payment means the date of the negotiable instrument of an amount due and payable by the Receiver General for Canada.
- Fixed Price Arrangement means that part of the Contract that prescribes a lump sum as payment for performance of the Work to which it relates.
- Unit Price Arrangement means that part of the Contract that prescribes the product of a Price Per Unit multiplied by a number of Units of Measurement of a Class as payment for performance of the Work to which it relates.
- Price Table means the table set out in the BID AND ACCEPTANCE FORM.
- Bank Rate means the rate of interest established from time to time by the Bank of Canada as the minimum rate at which the Bank of Canada makes short term advances to members of the Canadian Payments Association.
- Average Bank Rate means the simple arithmetic mean of the Bank Rates in effect at 4:00 pm Eastern Time each day during the calendar month which immediately precedes the calendar month in which payment is made.
- Duration of the Work means the number of calendar days required to complete the Work, commencing on the first day following receipt by the Contractor of the fully executed Contract and ending the day on which the Departmental Representative verifies that the Work has been satisfactorily completed.

GC 5.2 Payment - General Provisions

GENERAL CONDITIONS FOR MINOR WORKS (Continued)

1. It is a condition precedent to Canada's obligation under GC 5.3.5 that the Contractor has made and delivered to the Departmental Representative, a statutory declaration as described in GC 5.2.2.
2. A statutory declaration in a form acceptable to Canada shall contain a declaration that the Contractor has complied with all lawful obligations with respect to workers and that all lawful obligations towards Subcontractors and Suppliers in respect of the Work under the Contract have been fully discharged.
3. A payment by Canada pursuant to this section shall not be construed as evidence that the Work is satisfactory or in accordance with the Contract.
4. Delay in making payment by Canada under the Contract shall not constitute a breach of Contract.
5. Without limiting any right of setoff or deduction given or implied by law or elsewhere in the Contract, Canada may retain from amounts payable to the Contractor under the Contract, any amount payable to Canada by the Contractor under the Contract or any other current contract.
6. No additional payment shall be made for delays where the cause of the delay was under the control of the Contractor.
7. Except as provided for in these General Conditions, the amount payable to the Contractor under the Contract shall not be increased or decreased by reason of any increase or decrease in cost of the Work brought about by any increase in the cost of Labour, Plant or Material.
8. In the event of a change, including a new imposition or repeal of any tax, customs or other duty, charge, or any similar imposition that is imposed under sales or excise tax legislation of the Government of Canada or any Provincial or Territorial legislation, affects the cost of the Work to the Contractor, and occurs after the date of submission by the Contractor of the Contractor's bid, the contract amount shall be adjusted by an amount equal to the increased or decreased cost to the Contractor, which amount shall be determined through a detailed examination of the Contractor's records.
9. It is a term of every contract providing for the payment of any money by Her Majesty that payment under that contract is subject to there being an appropriation for the particular service for the fiscal year in which any commitment under that contract would come in course of payment. Section 40, *Financial Administration Act*, R.S., 1985, c. F-11, s. 40.

GC 5.3 Progress Payments

1. Where the duration of the Work is greater than thirty (30) days, the Contractor shall be entitled to receive monthly progress payments upon submitting a progress claim in a form approved by the Departmental Representative. Where the duration of the Work is less than thirty (30) days, the Contractor shall submit a progress claim after the Work is complete.
2. On the expiration of a Payment Period, the Contractor shall deliver to the Departmental Representative:
 - (a) a written progress claim that fully describes any part of the Work that has been satisfactorily completed and any Material that was delivered to the site of the Work but not incorporated into the Work during the Payment Period for which the progress claim relates;
 - (b) a completed and signed statutory declaration as described in GC 5.2.2; and

GENERAL CONDITIONS FOR MINOR WORKS (Continued)

- (c) in the case of the initial progress claim and the request for final payment, satisfactory evidence of compliance with workers compensation legislation that is applicable to the place of the Work.
- 3. Not later than ten (10) days after receipt of a progress claim properly submitted in accordance with GC 5.3.2, the Departmental Representative shall issue a progress report, a copy of which shall be given to the Contractor.
- 4. A progress report shall indicate the value of the part of the Work and Material described in the progress claim that, in the opinion of Canada:
 - (a) is in accordance with the Contract; and
 - (b) was not included in any other progress report related to the Contract.
- 5. Not later than thirty (30) days after the receipt by the Departmental Representative of a properly submitted progress claim and supporting documentation, Canada shall make a progress payment to the Contractor in an amount that is equal to one of the following:
 - (a) 90 percent of the value that is indicated in the progress report; or
 - (b) If the Departmental Representative is satisfied that the Work is substantially complete and is acceptable for use by Canada, 100 percent of the value of the Work and Material that is in accordance with the Contract, less amounts previously paid for under the Contract, less the amount equal to the estimated cost of completing the Work and the estimated cost of rectifying defects and faults in the Work as determined by the Departmental Representative; or
 - (c) If the Departmental Representative is satisfied that the Work is complete, 100 percent of the value of the Work that is in accordance with the Contract less amounts previously paid for under the Contract;plus Applicable Taxes and less the aggregate of any amounts payable to or costs and damages claimed by Canada or by a Claimant against the Contractor.
- 6. The Departmental Representative reserves the right to increase or decrease the quantities submitted by the Contractor if there is a disagreement between the Contractor's invoiced quantities and the quantities shown in the records maintained at the site of the Work.
- 7. Subject to GC 5.3.8, GC 5.3.9 and GC 5.3.10, the Departmental Representative and the Contractor may, by an agreement in writing, amend a Price Per Unit as set out in the Price Table for any Class of Labour, Plant or Material provided the Certificate of Measurement shows that the Authorized Quantity of the Class of Labour, Plant or Material actually performed, used or supplied by the Contractor in performing the Work is:
 - (a) less than 85 percent of the Estimated Total Quantity; or
 - (b) in excess of 115 percent of the Estimated Total Quantity.
- 8. In no event shall the total amount of an Item set out in the Price Table that has been amended pursuant to GC 5.3.7 (a) exceed the amount that would have been Payable to the Contractor had the Estimated Total Quantity actually been performed, used, or supplied.
- 9. An amendment that is made necessary by GC 5.3.7 (b) shall apply only to the quantities that are in excess of 115 percent.
- 10. Where the Departmental Representative and the Contractor fail to agree on the amount of any adjustment to a Price Per Unit as contemplated by GC 5.3.7, the amended Price Per Unit shall be determined in accordance with GC 5.7.

GENERAL CONDITIONS FOR MINOR WORKS (Continued)

GC 5.4 Interest on Overdue Accounts

1. Canada shall be liable to pay, to the Contractor, simple interest at the Average Bank Rate plus 3 percent per annum on any amount that is Overdue. The interest shall apply from the date such amount becomes Overdue until the day prior to the Date of Payment inclusively.
2. Interest shall be paid to the Contractor without demand on Overdue payments, except, in respect to amounts which are less than fifteen (15) days Overdue, in which case, no interest shall be paid unless the Contractor so demands.
3. Canada shall not be liable to pay interest where Canada is not responsible for the delay in paying the Contractor.

GC 5.5 Payment in the Event of Termination

1. If the Contract is terminated pursuant to GC 7.4, Canada shall pay the Contractor:
 - (a) an amount, as agreed upon by the Contractor and the Departmental Representative, for all Labour, Plant and Material performed, used or supplied by the Contractor as at the date of termination plus
 - (i) any fully supported termination costs incurred by the Contractor, less
 - (ii) any amounts payable to or costs and damages claimed by Canada or by a Claimant, against the Contractor; or
 - (b) failing such an agreement, an amount calculated in accordance with GC 5.7.2.

GC 5.6 Final Completion

1. A Certificate of Completion shall be issued to the Contractor on the date on which the Work has been completed and the Contractor has complied with the Contract and all orders and directions made pursuant thereto, all to the satisfaction of the Departmental Representative.
2. Where the Contract is, in whole or in part, a Unit Price Arrangement, the Departmental Representative shall, at the same time as the issuance of the Certificate of Completion, issue a Certificate of Measurement setting out the Authorized Quantities used or employed in respect of the classes and units set out in the Price Table under the BID AND ACCEPTANCE FORM and any subsequent amendments thereto, such certificate to be binding upon the Contractor and Canada.

GC 5.7 Determination of Price

1. By mutual agreement:
 - (a) where a Lump Sum Arrangement applies to the Contract or a part thereof, the price of any change shall be the aggregate estimated cost of Labour, Plant and Material that is required for the change as agreed upon in writing by the Contractor and Canada, and include an allowance for overhead, margin and the risk of undertaking the work within the stipulated amount;
 - (b) where a Unit Price Arrangement applies to the Contract or a part thereof, the Contractor and Canada may, by agreement in writing, add Items, Units of Measurement, Estimated Total Quantities and Price Per Units to the Price Table;
 - (c) a Price Per Unit referred to in GC 5.7.1 (b) shall be determined on the basis of the aggregate estimated cost of Labour, Plant and Material that is required for the additional Item as agreed upon by the Contractor and Canada, and include an allowance for overhead, margin and the risk of undertaking the work;

GENERAL CONDITIONS FOR MINOR WORKS (Continued)

- (d) to facilitate approval of the price of the additional Item, the Contractor shall submit a cost estimate breakdown identifying, as a minimum, the estimated cost of Labour, Plant, Material, each subcontract amount, and the amount of the appropriate percentage allowance;
- (e) if no agreement can be reached as contemplated in GC5.7.1 (a), the price shall be determined in accordance with GC 5.7.2; and
- (f) if no agreement can be reached as contemplated in GC 5.7.1 (b) and GC 5.7.1 (c), the Departmental Representative shall determine the Class and the Unit of Measurement of the Item of Labour, Plant or Material and the Price Per Unit shall be determined in accordance with GC 5.7.2.

2. Following Completion of the Additional Work

- (a) Where it is not possible to predetermine, or where there is failure to agree upon the price of a change in the Work, the price of the change shall be equal to the aggregate of:
 - (i) all reasonable and proper amounts actually expended or legally payable by the Contractor in respect of the Labour, Plant and Material that fall within one of the classes of expenditure described in GC 5.7.2(b), that are directly attributable to the performance of the Contract; plus
 - (ii) an allowance for profit and all other expenditures or costs equal to 10 percent of the sum of the amounts referred to in GC 5.7.2 (a)(i); plus
 - (iii) interest, if any, paid by the Contractor on the amounts determined under GC 5.7.2 (a)(i) and (ii), calculated in accordance with GC 5.4.
- (b) The cost of Labour, Plant and Material referred to in GC 5.7.2 (a) shall be limited to the following categories of expenditure:
 - (i) payments to Subcontractors and suppliers;
 - (ii) wages, salaries and traveling expenses of employees of the Contractor located at the site of the Work and that portion of wages, salaries, bonuses, living and traveling expenses of personnel of the Contractor generally employed at the head office or at a general office of the Contractor provided they are actually and properly engaged on the Work under the Contract;
 - (iii) assessments payable under any statutory authority relating to workers' compensation, employment insurance, pension plan or holidays with pay, provincial health or insurance plans, environmental reviews, and GST/HST collection costs;
 - (iv) rent that is paid for Plant, or an amount equivalent to the said rent if the Plant is owned by the Contractor, that is necessary for and used in the performance of the Work, if the rent or the equivalent amount is reasonable and use of that Plant had been approved by the Departmental Representative;
 - (v) payments for maintaining and operating Plant necessary for and used in the performance of the Work, and payments for effecting repairs thereto that, in the opinion of the Departmental Representative, are necessary for the proper performance of the Contract, other than payments for any repairs to the Plant arising out of defects existing before its allocation to the Work;
 - (vi) payments for Material that is necessary for and incorporated in the Work, or that is necessary for and consumed in the performance of the Contract;
 - (vii) payments for preparation, delivery, handling, erection, installation, inspection, protection and removal of the Plant and Material necessary for and used in the performance of the Contract; and
 - (viii) any other payments made by the Contractor with the approval of the Departmental Representative that are necessary for the performance of the Contract in accordance with the Contract Documents.

GC 5.8 Claims Against and Obligations of the Contractor or Subcontractor

GENERAL CONDITIONS FOR MINOR WORKS (Continued)

1. The Contractor shall ensure that all its lawful obligations arising out of the performance of the Work are discharged and satisfied at least as often as the Contract requires Canada to pay the Contractor. The Contractor shall provide the Departmental Representative with a Statutory Declaration, as referred to in GC 5.2.2. If any third party claims and outstanding obligations exist under the Contract, a Statutory Declaration shall also be accompanied by letter documentation that clearly identifies the existence and condition of any third party disputed claims and outstanding obligations.
2. In order to discharge lawful obligations of and satisfy lawful claims against the Contractor or a Subcontractor arising out of the performance of the Work, Canada may:
 - (a) pay an amount from money that is due and payable to the Contractor pursuant to the Contract directly to the claimant against the Contractor or the Subcontractor; or
 - (b) withhold from any amount that is due and payable to the Contractor pursuant to the Contract the full amount of the claim or any portion thereof. Monies withheld for this purpose shall not be subject to any interest payment in the event such claims are rejected.
3. The amount referred to in GC 5.8.2 (a) shall be that amount which the Contractor would have been obliged to pay to such claimant had the provisions of the Provincial or Territorial lien legislation, or in the province of Quebec, the law relating to mortgage, been applicable to the Work. Any such claimant need not comply with the provisions of such legislation setting out the steps by way of notice, registration, or otherwise as might have been necessary to preserve or perfect any claim for lien or mortgage which the claimant might have had.
4. For the purposes of GC 5.8, a claim shall be considered lawful when it is so determined:
 - (a) by a court of competent jurisdiction;
 - (b) by an arbitrator duly appointed to arbitrate the said claim; or
 - (c) by written notice delivered to the Departmental Representative and signed by the Contractor authorizing payment of the said claim(s).
5. A payment made pursuant to GC 5.8.2 is, to the extent of the payment, a discharge of Canada's liability to the Contractor under the Contract and may be deducted from any amount payable to the Contractor under the Contract.
6. GC 5.8.2 shall only apply to claims and obligations where:
 - (a) the notification of which has set forth the amount claimed to be owing and the person who by Contract is primarily liable;
 - (b) the notification or a copy of the notification was received by the Departmental Representative in writing before final payment is made to the Contractor and within one hundred and twenty (120) days of the date on which the claimant:
 - (i) should have been paid in full under the claimant's Contract with the Contractor or Subcontractor where the claim is for money that was lawfully required to be held back from the claimant; or
 - (ii) performed the last of the labour or furnished the last of the Plant or Material pursuant to the claimant's Contract with the Contractor or Subcontractor where the claim is not for money referred to in GC 5.8.6 (b)(i); and
 - (c) the proceedings to determine the right to payment for the claim shall have commenced within one year from the date that the notice referred to in GC 5.8.6 (b) was received by the Department Representative.
7. The Departmental Representative shall inform the Contractor in writing of receipt of any notification of claim and of the intention of Canada to withhold funds pursuant to GC 5.8.2. The Contractor may, at any time thereafter and until payment is made to the claimant, post with Canada, security in the form of a Claimant's Payment Bond acceptable to Canada and in an

GENERAL CONDITIONS FOR MINOR WORKS (Continued)

amount equal to the value of the said claim. Upon receipt of such security Canada shall release to the Contractor any funds which would be otherwise payable to the Contractor, that were withheld pursuant to the provisions of GC 5.8.2.

GC 6 CHANGES IN THE WORK

GC 6.1 Changes in the Work

1. Canada shall have the right to order additional Work, dispense with, or change the whole or any part of the Work described in the Drawings and Specifications or Scope of the Work.
2. The Departmental Representative shall decide whether anything done or not done as a result of directions given under GC 6.1.1 has increased or decreased the cost of the Work to the Contractor and where the cost of the Work has increased or decreased, the amount payable under the Contract shall be increased or decreased by an amount calculated in accordance with GC5.7.
3. Any change in the terms of the Contract, other than changes that may be ordered by Canada or the Departmental Representative pursuant to GC 6.1.1, may be made only by agreement in writing between Canada and the Contractor.

GC 6.2 Changes in Subsurface Conditions and Delays by Canada

1. No extra payment shall be made to the Contractor for any extra expense, loss or damage for any reason unless Canada shall certify that such extra expense, loss or damage is directly attributable to:
 - (a) a substantial difference between the subsurface conditions as indicated in the Drawings and Specifications or Scope of Work and the actual conditions found at the site of the Work; or
 - (b) the neglect or delay by Canada, occurring after the date of award of the Contract:
 - (i) in providing any information or the doing of any act which Canada is required expressly by the Contract to do or as required by a known custom of the trade; or
 - (ii) in suspending the Work pursuant to GC 7.3.
2. The Contractor shall, within ten (10) days immediately after encountering such subsurface conditions or such neglect or delay, give written notice to the Departmental Representative of a claim for such extra expense, loss or damage. Failure to provide such written notice shall render the claim null and void.
3. The amount of any extra payment made under this section shall be calculated in accordance with GC 5.7.
4. If, in the opinion of the Departmental Representative, any difference in subsurface conditions referred to in GC 6.2.1 results in a savings to the Contractor, the amount of said savings shall be deducted from the Contract Amount owing to the Contractor.

GC 6.3 Extension of Time

1. Upon written application by the Contractor made before the date fixed for the completion of the Work, Canada may extend the time for completion of the Work if, in the opinion of Canada causes beyond the control of the Contractor have delayed its completion.
2. If the Contractor does not complete the Work by the day fixed for its completion, but completes it thereafter, the Contractor shall:

GENERAL CONDITIONS FOR MINOR WORKS (Continued)

- (a) pay all Canada's inspection costs relating to the Work incurred after the stipulated completion date; and
- (b) compensate Canada for any loss or damage resulting from the failure by the Contractor to complete the Work by the completion date fixed by the Contract.

Unless, in the opinion of Canada, such delay was due to causes beyond the control of the Contractor or it is in the public interest to waive the whole or any part of the payment.

GC 7 DEFAULT, SUSPENSION OR TERMINATION OF CONTRACT

GC 7.1 Taking the Work Out of the Contractor's Hands

1. By giving notice in writing to the Contractor, Canada may take all or any part of the Work out of the Contractor's hands, and may employ such means as Canada sees fit to have the Work completed if the Contractor:
 - (a) fails to remedy any delay in the commencement or default in the execution of the Work to the satisfaction of the Departmental Representative within six (6) days of Canada giving written notice to the Contractor to do so;
 - (b) defaults in the completion of any part of the Work within the time fixed by the Contract for its completion;
 - (c) becomes insolvent or commits an act of bankruptcy and has neither made a proposal to its creditors nor filed a notice of intention to make such a proposal pursuant to the *Bankruptcy and Insolvency Act*;
 - (d) abandons the Work;
 - (e) makes an assignment contrary to GC 1.3; and or
 - (f) otherwise fails to observe or perform any of the provisions of the Contract.
2. If the whole or any part of the Work is taken out of the Contractor's hands, the Contractor's right to any further payment that is due or accruing due under the Contract is extinguished.
3. The Contractor shall be liable to pay Canada, upon demand, an amount that is equal to the sum of all losses and damages incurred or sustained by Canada in respect of the Contractor's failure to complete the Work.
4. If the whole or any part of the Work that is taken out of the Contractor's hands pursuant to GC 7.1.1 is completed by Canada, the Departmental Representative shall calculate the amount, if any, of the holdback or progress claims that had accrued and was due prior to the date on which the Work was taken out of the Contractor's hands.
5. If it is determined that there is an amount that is not required for the purposes of having the Work performed or of compensating Canada for any other loss or damage incurred or sustained by reason of the Contractor's default, Canada may then pay the Contractor the amount determined not to be required pursuant to GC 7.1.4.

GC 7.2 Effect of Taking the Work Out of the Contractor's Hands

1. The taking of the Work or part thereof out of the Contractor's hands pursuant to GC 7.1.1 does not operate so as to relieve or discharge the Contractor from any obligations under the Contract or imposed upon the Contractor by law except the obligation to complete the performance of that part of the Work that was taken out of the Contractor's hands.
2. All Plant and Material and the interest of the Contractor in all real property, licenses, powers and privileges acquired, used, provided or consumed by the Contractor under the Contract shall continue to be the property of Canada without compensation to the Contractor.

GENERAL CONDITIONS FOR MINOR WORKS (Continued)

3. When the Departmental Representative certifies that any Plant, Material or any interest of the Contractor referred to in GC 7.2, is no longer required for the purpose of the Work, or that it is not in the interests of Canada to retain that Plant, Material or interest, it shall revert to the Contractor.

GC 7.3 Suspension of the Contract

1. Canada may, upon giving notice in writing to the Contractor, suspend the performance of the Work at any time. The Contractor shall comply with such notice immediately, subject to any conditions that may be stipulated in the notice.
2. If Canada suspends the Work for thirty (30) days or less the Contractor shall, subject to its remedy under GC 5.7, complete the Work when called upon to do so. If Canada suspends the Work for a period in excess of thirty (30) days, the Contractor may request that Canada terminate the Contract pursuant to GC 7.4.
3. It is the responsibility of the Contractor to mitigate all costs during the suspension period.

GC 7.4 Termination of the Contract

1. Canada may terminate the Contract at any time by giving notice of termination in writing to the Contractor and upon receipt of such notice the Contractor shall cease all operations in performance of the Contract, subject to any conditions that may be stipulated in the notice.
2. Termination under GC 7.4.1 shall not relieve the Contractor of any legal or contractual obligations other than that portion of Work that remains to be completed at the time of the termination.
3. Payment, in event of termination under this subsection, shall be made pursuant to the provision of GC 5.5.

GC 8 DISPUTE RESOLUTION

1. The Contractor may, within 10 days after the communication to the Contractor of any decision or direction referred to in GC2.1(b) and GC6.1, protest that decision or direction.
2. A protest referred to in GC8.1 shall be in writing, contain full reasons for the protest, be signed by the Contractor and be given to Canada.
3. If the Contractor gives a protest pursuant to GC8.2, any compliance by the Contractor with the decision or direction that was protested shall not be construed as an admission by the Contractor of the correctness of that decision or direction, or prevent the Contractor from taking whatever action the Contractor considers appropriate in the circumstances.
4. The giving of a protest by the Contractor pursuant to GC8.2 shall not relieve the Contractor from complying with the decision or direction that is the subject of the protest.
5. Subject to GC8.6, the Contractor shall take any action referred to in GC8.3 within 3 months after the date of the Certificate of Completion referred to in GC5.6 and not afterwards, except where it is otherwise provided by law.
6. The Contractor shall take any action referred to in GC8.3 resulting from a direction under GC3.4, within 3 months after the expiry of a warranty or guarantee period and not afterwards, except where it is otherwise provided by law.

GENERAL CONDITIONS FOR MINOR WORKS (Continued)

7. Subject to GC8.8, if Canada determines that the Contractor's protest is justified, Canada shall pay the Contractor the cost of the additional labour, Plant and Material necessarily incurred by the Contractor in carrying out the protested decision or direction.
8. Costs referred to in GC8.7 shall be calculated in accordance with GC5.7.

GC 9 INDEMNIFICATION AND INSURANCE

GC 9.1 Indemnification

1. The Contractor shall indemnify and save harmless Canada, its servants, agents and all those for whom Canada may be, in law, responsible, from and against all claims, demands, losses, damages, costs and legal proceedings by whomever made, sustained, brought or prosecuted, and in any manner based upon, occasioned by or attributed to the activities of the Contractor, the Contractor's employees, agents or persons for whom the Contractor is, in law, responsible for the performance or purported performance of the Contract, including an infringement or alleged infringement of a patent of invention or any other kind of intellectual property.
2. For the purpose of GC 9.1.1, activities include any act improperly carried out and any omission or delay in carrying out an act.
3. The Contractor's liability to indemnify or reimburse Canada under the Contract shall not affect or prejudice Canada from exercising any rights available to Canada at law or in equity.

GC 9.2 Insurance Contracts

1. The Contractor shall, at the Contractor's expense, obtain and maintain insurance contracts in respect of the work and shall provide evidence thereof to Canada in accordance with the requirements of the INSURANCE TERMS.
2. The insurance contracts referred to in GC 9.2.1 shall:
 - (a) be in a form, of the nature, in the amounts, for the periods and containing the terms and conditions specified in INSURANCE TERMS; and
 - (b) provide for the payment of claims under such insurance contracts in accordance with GC 9.3.

GC 9.3 Insurance Proceeds

1. In the case of a claim payable under a Builders Risk/Installation (All Risks) insurance contract maintained by the Contractor pursuant to GC 9.2, the proceeds of the claim shall be paid directly to Canada, and
 - (a) the monies so paid shall be held by Canada for the purposes of the Contract, or
 - (b) if Canada elects, shall be retained by Canada, in which event they vest in Canada absolutely.
2. In the case of a claim payable under a General Liability insurance contract maintained by the Contractor pursuant to GC 9.2, the proceeds of the claim shall be paid by the insurer directly to the claimant.
3. If an election is made pursuant to GC 9.3.1, Canada may cause an audit to be made of the accounts of the Contractor and of Canada in respect of the part of the work that was lost, damaged or destroyed for the purpose of establishing the difference, if any, between
 - (a) the aggregate of the amount of the loss or damage suffered or sustained by Canada, including any costs incurred in respect of the clearing and cleaning of the Work and its

GENERAL CONDITIONS FOR MINOR WORKS (Continued)

- site and any other amount that is payable by the Contractor to Canada under the Contract, minus any monies retained pursuant to GC 9.3.1 (b); and
- (b) the aggregate of the amounts payable by Canada to the Contractor pursuant to the Contract up to the date of the loss or damage.
4. A difference that is established pursuant to GC 9.3.3 shall be paid forthwith by the party who is determined by the audit to be the debtor to the party who is determined by the audit to be the creditor.
 5. When payment of a deficiency has been made pursuant to GC 9.3.4, all rights and obligations of Canada and the Contractor under the Contract shall, with respect only to the part of the work that was the subject of the audit referred to in GC 9.3.3, be deemed to have been expended and discharged.
 6. If an election is not made pursuant to GC 9.3.1 (b), the Contractor shall, subject to GC 9.3.7, clear and clean the work and its site and restore and replace the part of the work that was lost, damaged or destroyed at the Contractor's expense as if that part of the work had not yet been performed.
 7. When the Contractor clears and cleans the Work and its site and restores and replaces the work referred to in GC 9.3.6, Canada shall pay the Contractor out of the monies referred to in GC 9.3.1 so far as they will thereon to extend.
 8. Subject to GC 9.3.7, payment by Canada pursuant to GC 9.3.7 shall be made in accordance with the Contract but the amount of each payment shall be 100 percent of the amount claimed notwithstanding GC 5.3 a) and b).



Appendix "E"

TECHNICAL SPECIFICATIONS & PLANS

SPECIFICATIONS:

<i>Section No.</i>	<i>Section Title</i>	<i>Pages</i>
DIVISION 01	GENERAL REQUIREMENTS	
01 00 10	General instructions	5
01 33 00	Submittal Procedures	4
01 35 29 06	Health and safety requirements	4
01 74 11	Cleaning	2
01 78 00	Closeout Submittals	6
01 91 13	General Commissioning (Cx) Requirements	8
01 91 33	Commissioning (Cx) Forms	3
DIVISION 02	EXISTING CONDITIONS	
02 61 33	Hazardous Materials	4
DIVISION 23	HVAC	
23 05 01	Common Work Results for HVAC	3
23 05 54	Mechanical Identification	5
23 05 93	Testing, Adjusting, and Balancing for HVAC	4
23 64 26	Scroll water chillers	8
DIVISION 26	ELECTRICAL	
26 05 00	Electrical General Requirements	6
26 05 20	Wire and Box Connectors (0-1000V)	1
26 05 21	Wires and Cables (0-1000V)	2
26 05 28	Grounding - Secondary	2
26 05 31	Splitters, Junction, Pull Boxes, and Cabinets	1
26 05 34	Conduits, Conduit Fastenings, and Conduit Fittings	2
26 28 21	Moulded Case Circuit Breakers	1
26 28 23	Disconnect Switches – Fused and Non-fused	1

PLANS:

	<i>Dwg.No.</i>	<i>Drawing Title</i>
Mechanical:	M-1	CHILLER REPLACEMENT

END OF SECTION

Part 1 General

1.1 MINIMUM STANDARDS

- .1 Materials shall be new and work shall conform to the minimum applicable standards of the Canadian General Standards Board, the Canadian Standards Association, the National Building Code of Canada 2010 (NBC) and all applicable Provincial and Municipal codes. In the case of conflict or discrepancy the most stringent requirement shall apply.

1.2 PRECEDENCE

1.3 SITE LOCATES AND CLEARANCE NUMBERS

- .1 Be responsible for all costs associated with obtaining site locates or clearance numbers for all utilities within the work area, including those utilities considered privately owned.
- .2 Engage the services of private locator firm to undertake the private locates. All known locations of Federal underground utilities (“private utilities”) are indicated in the contract documents.
- .3 Provide copies of written correspondence from each respective underground utility agencies pertaining to their utility locates or work site clearance numbers.

1.4 TAXES

- .1 Pay all taxes properly levied by law (including Federal, Provincial and Municipal).

1.5 FEES, PERMITS, AND CERTIFICATES

- .1 Pay all fees and obtain all permits. Provide authorities with plans and information for acceptance certificates. Provide inspection certificates as evidence that work conforms to requirements of Authority having jurisdiction.

1.6 FIRE SAFETY REQUIREMENTS

- .1 Comply with the National Building Code of Canada 2010 (NBC) for fire safety in construction and the National Fire Code of Canada 2010 (NFC) for fire prevention, fire fighting and life safety in building in use.

1.7 HAZARDOUS MATERIALS

- .1 Comply with the requirements of the Workplace Hazardous Materials Information System (WHMIS) regarding use, handling, storage, and disposal of hazardous materials; and regarding labelling and the provision of Material Safety Data Sheets (MSDS) acceptable to Human Resources Development Canada, Labour Program.
- .2 For work in occupied buildings give the Departmental Representative 48 hours notice for work involving designated substances (Ontario Bill 208), hazardous substances (Canada Labour Code Part II Section 10)

1.8 WELDING AND CUTTING

- .1 At least 48 hours prior to commencing cutting or welding, provide to Departmental Representative:

- .1 Completed welding permit.
- .2 Return welding permit to Departmental Representative immediately upon completion of procedures for which permit was issued.
- .3 A firewatcher shall be assigned when welding or cutting operations are carried out in areas where combustible materials within 10m may be ignited by conduction or radiation.

1.9 FIELD QUALITY CONTROL

- .1 Carry out Work using qualified licensed workers or apprentices in accordance with Provincial Act respecting manpower vocational training and qualification.
- .2 Permit employees registered in Provincial apprenticeship program to perform specific tasks only if under direct supervision of qualified licensed workers.
- .3 Determine permitted activities and tasks by apprentices, based on level of training attended and demonstration of ability to perform specific duties.

1.10 TEMPORARY UTILITIES

- .1 Existing services required for the work, are not to be used by the Contractor. Contractor responsible to supply all portable generators as required to meet all power requirements of the equipment and machinery required to undertake the work.
- .2 All water requirements for execution of this contract are the responsibility of the contractor to provide from off-site sources.

1.11 REMOVED MATERIALS

- .1 Unless otherwise specified, materials for removal become the Contractor's property and shall be taken from site.

1.12 PROTECTION

- .1 Protect adjacent work against the spread of dust and dirt beyond the work areas.
- .2 Protect finished work against damage until take-over.
- .3 Protect operatives and other users of site from all hazards.

1.13 HOARDING

- .1 Erect temporary site enclosure around work site, including excavations.
- .2 Hoarding to be in full compliance with requirements of the Ontario Health and Safety Act and Regulations - 1990 (OHSA).
 - .1 Hoarding around the work site shall consist of: new 1.2m high snow fence wired to rolled steel "T" bar fence posts spaced at 2.4m o.c. complete with 2x4 lumber support for top of fence.
 - .2 In accordance with OHSA, where required, provide 1.8m high sturdy fence to protect personnel from hazards.
- .3 Keep site fenced off at all times from general public. Only remove portion of fence to provide opening to site to accommodate access, minimize duration of opening, and immediately close when not required.
- .4 Ensure site is fully enclosed when work force is not on site.
- .5 Continually monitor condition of hoarding and make good repairs.

1.14 USE OF SITE AND FACILITIES

- .1 Execute work with least possible interference or disturbance to the normal use of premises. Make arrangements with Departmental Representative to facilitate work as stated.
- .2 Maintain existing services to building and provide for personnel and vehicle access, including emergency vehicles.
- .3 Maintain vehicle and pedestrian access, including emergency vehicles to and from the site.
- .4 Where security is reduced by work provide temporary means to maintain security.

1.15 SANITARY FACILITIES

- .1 Provide sanitary facilities for work force in accordance with governing regulations and ordinances.
- .2 Post notices and take precautions as required by local health authorities. Keep area and premises in sanitary condition.
- .3 Location of portable facility to be approved by Departmental Representative on site.

1.16 SITE STORAGE

- .1 Storage and stockpile areas shall be equipped and maintained by the contractor.
 - .1 Storage and stockpile areas are to be contained entirely within the laydown/work area indicated.
 - .2 Contractor employee parking shall be contained within the indicated laydown/work area
- .2 Do not unreasonably encumber site with materials or equipment.
- .3 Move stored products or equipment, which interfere with operations of Departmental Representative or other contractors.
- .4 Obtain and pay for use of additional storage or work areas needed for operations.

1.17 CUT, PATCH AND MAKE GOOD

- .1 Cut existing surfaces as required to accommodate new work.
- .2 Remove all items so shown or specified.
- .3 Patch and make good surfaces cut, damaged or disturbed, to Departmental Representative's approval. Match existing material, colour, finish and texture.

1.18 EXAMINATION

- .1 Examine site and conditions likely to affect work and be familiar and conversant with existing conditions.

1.19 SIGNS

- .1 Provide common-use signs related to traffic control, information, instruction, use of equipment, public safety devices, etcetera, in both official languages or by the use of commonly understood graphic symbols to the Departmental Representative's approval.

- .2 No advertising will be permitted on this project.

1.20 ACCESS AND EGRESS

- .1 Design, construct and maintain temporary "access to" and "egress from" work areas, including stairs, runways, ramps or ladders, independent of finished surfaces and in accordance with relevant municipal, provincial and other regulations.

1.21 BUILDING SMOKING ENVIRONMENT

- .1 Smoking is not permitted in the Building. Obey smoking restrictions on building property.

1.22 DUST CONTROL

- .1 Prevent the spread of dust for the protection of workers, finished areas of work and public.

1.23 TESTING LABORATORY SERVICES

- .1 Departmental Representative will appoint and pay for costs of inspection and testing services, unless indicated otherwise.
- .2 Provide safe working areas and assist with testing procedures, including provisions for materials or services and co-ordination, as required by testing agency and as authorized by Departmental Representative.
- .3 Where tests indicate non-compliance with specifications, contractor to pay for initial test and all subsequent testing of work to verify acceptability of corrected work.

1.24 SCHEDULING

- .1 On award of contract submit bar chart construction schedule for work, indicating anticipated progress stages within time of completion. When schedule has been reviewed by the Departmental Representative, take necessary measures to complete work within scheduled time. Do not change schedule without notifying Departmental Representative.
- .2 Carry out work during "regular hour" Monday to Friday from 07:00 to 18:00 hours, unless otherwise indicated.
- .3 Carry out the following work during "off hours", as defined as Monday to Friday from 18:00 to 07:00 hours and anytime on Saturdays, Sundays, and statutory holidays:
 - .1 Building service interruptions.
 - .2 Connections of new water main to live water mains.
- .4 Give the Departmental Representative 96 hours notice for work to be carried out during "off hours".

1.25 COST BREAKDOWN

- .1 Before submitting first progress claim submit breakdown of Contract Amount in detail as directed by Departmental Representative and aggregating the Contract Amount. After approval by Departmental Representative cost breakdown will be used as the basis of progress payments.

Part 2 Products

2.1 **NOT USED**

Part 3 **Execution**

3.1 **NOT USED**

END OF SECTION

Part 1 General

1.1 ADMINISTRATIVE

- .1 Submit to Departmental Representative submittals listed for review. Submit promptly and in orderly sequence to not cause delay in Work. Failure to submit in ample time is not considered sufficient reason for extension of Contract Time and no claim for extension by reason of such default will be allowed.
- .2 Do not proceed with Work affected by submittal until review is complete.
- .3 Present shop drawings, product data, samples, and mock-ups in SI Metric units.
- .4 Where items or information is not produced in SI Metric units, converted values are acceptable. Review submittals prior to submission to Departmental Representative. This review represents that necessary requirements have been determined and verified, or will be, and that each submittal has been checked and co-ordinated with requirements of Work and Contract Documents. Submittals not stamped, signed, dated and identified as to specific project will be returned without being examined and considered rejected.
- .5 Notify Departmental Representative, in writing at time of submission, identifying deviations from requirements of Contract Documents stating reasons for deviations.
- .6 Verify field measurements and affected adjacent Work are co-ordinated.
- .7 Contractor's responsibility for errors and omissions in submission is not relieved by Departmental Representative's review of submittals.
- .8 Contractor's responsibility for deviations in submission from requirements of Contract Documents is not relieved by Departmental Representative's review.
- .9 Keep one (1) reviewed copy of each submission on site.

1.2 SHOP DRAWINGS AND PRODUCT DATA

- .1 The term "shop drawings" means drawings, diagrams, illustrations, schedules, performance charts, brochures, and other data which are to be provided by Contractor to illustrate details of a portion of Work.
- .2 Where requested in documents submit shop drawings bearing stamp and signature of qualified professional Engineer registered or licensed in the Province of Ontario.
- .3 Indicate materials, methods of construction and attachment or anchorage, erection diagrams, connections, explanatory notes and other information necessary for completion of Work. Where articles or equipment attach or connect to other articles or equipment, indicate that such items have been co-ordinated, regardless of Section under which adjacent items will be supplied and installed. Indicate cross-references to design drawings and specifications.
- .4 Allow 5 days for Departmental Representative's review of each submission.
- .5 Adjustments made on shop drawings by Departmental Representative are not intended to change Contract Price. If adjustments affect value of Work, state such in writing to Departmental Representative prior to proceeding with Work.
- .6 Make changes in shop drawings as Departmental Representative may require, consistent with Contract Documents. When resubmitting, notify Departmental Representative in writing of revisions other than those requested.

- .7 Accompany submissions with transmittal letter, in duplicate, containing:
 - .1 Date.
 - .2 Project title and number.
 - .3 Contractor's name and address.
 - .4 Identification and quantity of each shop drawing, product data and sample.
 - .5 Other pertinent data.
- .8 Submissions include:
 - .1 Date and revision dates.
 - .2 Project title and number.
 - .3 Name and address of:
 - .1 Subcontractor.
 - .2 Supplier/Manufacturer.
 - .4 Contractor's stamp, signed by Contractor's authorized representative certifying approval of submissions, verification of field measurements and compliance with Contract Documents.
 - .5 Details of appropriate portions of Work as applicable:
 - .1 Fabrication.
 - .2 Layout, showing dimensions, including identified field dimensions, and clearances.
 - .3 Setting or erection details.
 - .4 Capacities.
 - .5 Performance characteristics.
 - .6 Standards.
 - .7 Operating weight.
 - .8 Wiring diagrams.
 - .9 Single line and schematic diagrams.
 - .10 Relationship to adjacent work.
- .9 After Departmental Representative's review, distribute copies.
- .10 Submit electronic copy of shop drawings for each requirement requested in specification Sections and as Departmental Representative may reasonably request.
- .11 Submit electronic copies of product data sheets or brochures for requirements requested in specification Sections and as requested by Departmental Representative where shop drawings will not be prepared due to standardized manufacture of product.
- .12 Submit electronic copies of test reports for requirements requested in specification Sections and as requested by Departmental Representative.
 - .1 Report signed by authorized official of testing laboratory that material, product, or system identical to material, product, or system to be provided has been tested in accord with specified requirements.
 - .2 Testing must have been performed within three (3) years of date of contract award for project.
- .13 Submit electronic copies of certificates for requirements requested in specification Sections and as requested by Departmental Representative.

- .1 Statements printed on manufacturer's letterhead and signed by responsible officials of manufacturer of product, system, or material attesting that product, system, or material meets specification requirements.
- .2 Certificates must be dated after award of project contract complete with project name.
- .14 Submit electronic copies of manufacturers instructions for requirements requested in specification Sections and as requested by Departmental Representative.
 - .1 Pre-printed material describing installation of product, system, or material, including special notices and Material Safety Data Sheets concerning impedances, hazards, and safety precautions.
- .15 Submit electronic copies of Manufacturer's Field Reports for requirements requested in specification Sections and as requested by Departmental Representative. Documentation of the testing and verification actions taken by manufacturer's representative to confirm compliance with manufacturer's standards or instructions.
- .16 Submit electronic copies of Operation and Maintenance Data for requirements requested in specification Sections and as requested by Departmental Representative.
- .17 Delete information not applicable to project.
- .18 Supplement standard information to provide details applicable to project.
- .19 If upon review by Departmental Representative, no errors or omissions are discovered or if only minor corrections are made, reviewed shop drawings will be returned and fabrication and installation of Work may proceed. If shop drawings are rejected, a noted copy will be returned and resubmission of corrected shop drawings, through same procedure indicated above, must be performed before fabrication and installation of Work may proceed.

1.3 SAMPLES

- .1 Submit for review samples in duplicate as requested in respective specification Sections. Label samples with origin and intended use.
- .2 Deliver samples prepaid to Departmental Representative's site office.
- .3 Notify Departmental Representative, in writing, at time of submission of deviations in samples from requirements of Contract Documents.
- .4 Where colour, pattern or texture is criterion, submit full range of samples.
- .5 Adjustments made on samples by Departmental Representative are not intended to change Contract Price. If adjustments affect value of Work, state such in writing to Departmental Representative prior to proceeding with Work.
- .6 Make changes in samples, which Departmental Representative may require, consistent with Contract Documents.
- .7 Reviewed and accepted samples will become standard of workmanship and material against which installed Work will be verified.

1.4 PROGRESS PHOTOGRAPHS

- .1 Submit progress photographs.

1.5 CERTIFICATES AND TRANSCRIPTS

- .1 Immediately after award of Contract, submit Workers' Compensation Board status.

- .2 Submit transcription of insurance immediately after award of Contract.

Part 2 Products

2.1 NOT USED

- .1 Not Used.

Part 3 Execution

3.1 NOT USED

- .1 Not Used.

END OF SECTION

Part 1 General

1.1 REFERENCES

- .1 Province of Ontario
 - .1 Occupational Health and Safety Act, R.S.O. 1990 Updated 2005.

1.2 SUBMITTALS

- .1 Submit site-specific Health and Safety Plan: Within 5 days after date of Notice to Proceed and prior to commencement of Work. Health and Safety Plan must include:
 - .1 Results of site specific safety hazard assessment.
 - .2 Results of safety and health risk or hazard analysis for site tasks and operation found in work plan.
- .2 Submit 2 copies of Contractor's authorized representative's work site health and safety inspection reports to Departmental Representative weekly.
- .3 Submit copies of reports or directions issued by Federal, Provincial and Territorial health and safety inspectors.
- .4 Submit copies of incident and accident reports.
- .5 Submit WHMIS MSDS - Material Safety Data Sheets in accordance with Section 01 00 10 – General Instructions.
- .6 Personnel training requirements including, but not limited to, the following:
 - .1 Training and qualifications of personnel and alternates responsible for site safety and health.
 - .2 Training requirements for hazards present on site.
 - .3 Training for use of personal protective equipment.
- .7 Departmental Representative will review Contractor's site-specific Health and Safety Plan and provide comments to Contractor within 3 days after receipt of plan. Revise plan as appropriate and resubmit plan to Departmental Representative within 2 days after receipt of comments from Departmental Representative.
- .8 Departmental Representative's review of Contractor's final Health and Safety plan should not be construed as approval and does not reduce the Contractor's overall responsibility for construction Health and Safety.
- .9 On-site Contingency and Emergency Response Plan: address standard operating procedures to be implemented during emergency situations.

1.3 FILING OF NOTICE

- .1 File Notice of Project with Provincial authorities prior to beginning of Work.

1.4 SAFETY ASSESSMENT

- .1 Perform site specific safety hazard assessment related to project.

1.5 MEETINGS

- .1 Schedule and administer Health and Safety meeting with Departmental Representative prior to commencement of Work.

1.6 REGULATORY REQUIREMENTS

- .1 Comply with specified standards and regulations to ensure safe operations at site containing hazardous or toxic materials.

1.7 PROJECT/SITE CONDITIONS

- .1 Work at site will involve contact with:
 - .1 Vehicular Traffic.
 - .2 Heavy Construction Equipment.
 - .3 Rotating Objects.
 - .4 Overhead hoisting.

1.8 GENERAL REQUIREMENTS

- .1 Develop written site-specific Health and Safety Plan based on hazard assessment prior to beginning site Work and continue to implement, maintain, and enforce plan until final demobilization from site. Health and Safety Plan must address project specifications.
- .2 Departmental Representative may respond in writing, where deficiencies or concerns are noted and may request re-submission with correction of deficiencies or concerns. Relief from or substitution for any portion or provision of minimum Health and Safety Guidelines specified herein or reviewed site-specific Health and Safety Plan must be submitted to Departmental Representative in writing. Departmental Representative will respond in writing, either accepting or requesting improvements.

1.9 RESPONSIBILITY

- .1 Be responsible for health and safety of persons on site, safety of property on site and for protection of persons adjacent to site and environment to extent that they may be affected by conduct of Work.
- .2 Comply with and enforce compliance by employees with safety requirements of Contract Documents, applicable federal, provincial, territorial and local statutes, regulations, and ordinances, and with site-specific Health and Safety Plan.

1.10 COMPLIANCE REQUIREMENTS

- .1 Comply with Ontario Health and Safety Act, R.S.O.

1.11 UNFORSEEN HAZARDS

- .1 When unforeseen or peculiar safety-related factor, hazard, or condition occur during performance of Work, follow procedures in place for Employee's Right to Refuse Work in accordance with Acts and Regulations of Province having jurisdiction and advise Departmental Representative verbally and in writing.

1.12 HEALTH AND SAFETY CO-ORDINATOR

- .1 Employ and assign to Work, competent and authorized representative as Health and Safety Co-ordinator. Health and Safety Co-ordinator must:
 - .1 Have working knowledge of occupational safety and health regulations.
 - .2 Be responsible for completing Contractor's Health and Safety Training Sessions and ensuring that personnel not successfully completing required training are not permitted to enter site to perform Work.
 - .3 Be responsible for implementing, enforcing daily and monitoring site-specific Contractor's Health and Safety Plan.
 - .4 Be on site during execution of Work site supervisor.

1.13 POSTING OF DOCUMENTS

- .1 Ensure applicable items, articles, notices and orders are posted in conspicuous location on site in accordance with Acts and Regulations of Province having jurisdiction, and in consultation with Departmental Representative.

1.14 CORRECTION OF NON-COMPLIANCE

- .1 Immediately address health and safety non-compliance issues identified by authority having jurisdiction or by Departmental Representative.
- .2 Provide Departmental Representative with written report of action taken to correct non-compliance of health and safety issues identified.
- .3 Departmental Representative may stop Work if non-compliance of health and safety regulations is not corrected.

1.15 POWDER ACTUATED DEVICES

- .1 Use powder actuated devices only after receipt of written permission from Departmental Representative.
- .1 Give precedence to safety and health of public and site personnel and protection of environment over cost and schedule considerations for Work.

Part 2 Products

2.1 NOT USED

.1 Not used.

Part 3 Execution

3.1 NOT USED

.1 Not used.

END OF SECTION

Part 1 General

1.1 PROJECT CLEANLINESS

- .1 Maintain Work in tidy condition, free from accumulation of waste products and debris, including that caused by Owner or other Contractors.
- .2 Remove waste materials from site at daily regularly scheduled times or dispose of as directed by Departmental Representative. Do not burn waste materials on site, unless approved by Departmental Representative.
- .3 Clear snow and ice from access to building, bank/pile snow in designated areas only as directed by Departmental Representative. Make arrangements with and obtain permits from authorities having jurisdiction for disposal of waste and debris.
- .4 Provide on-site containers for collection of waste materials and debris.
- .5 Dispose of waste materials and debris as directed by Departmental Representative.
- .6 Store volatile waste in covered metal containers, and remove from premises at end of each working day.
- .7 Use only cleaning materials recommended by manufacturer of surface to be cleaned, and as recommended by cleaning material manufacturer.
- .8 Schedule cleaning operations so that resulting dust, debris and other contaminants will not fall on wet, newly painted surfaces nor contaminate building systems.

1.2 FINAL CLEANING

- .1 When Work is Substantially Performed remove surplus products, tools, construction machinery and equipment not required for performance of remaining Work.
- .2 Remove waste products and debris other than that caused by others, and leave Work clean and suitable for occupancy.
- .3 Prior to final review remove surplus products, tools, construction machinery and equipment.
- .4 Remove waste products and debris including that caused by Owner or other Contractors.
- .5 Remove waste materials from site at regularly scheduled times or dispose of as directed by Departmental Representative. Do not burn waste materials on site, unless approved by Departmental Representative.
- .6 Make arrangements with and obtain permits from authorities having jurisdiction for disposal of waste and debris.
- .7 Clean lighting reflectors, lenses, and other lighting surfaces.
- .8 Remove dirt and other disfiguration from exterior surfaces.
- .9 Sweep and wash clean paved areas. Clean equipment and fixtures to sanitary condition; clean or replace filters of mechanical equipment.
- .10 Remove snow and ice from access to building.

1.3 WASTE MANAGEMENT AND DISPOSAL

- .1 Not used.

Part 2 **Products**

2.1 **NOT USED**

.1 Not used.

Part 3 **Execution**

3.1 **NOT USED**

.1 Not used.

END OF SECTION

Part 1 General

1.1 SUBMITTALS

- .1 Submittals: in accordance with Section 01 33 00 - Submittal Procedures.
- .2 Prepare instructions and data using personnel experienced in maintenance and operation of described products.
- .3 Copy will be returned after final inspection, with Departmental Representative's comments.
- .4 Revise content of documents as required prior to final submittal.
- .5 Two (2) weeks prior to Substantial Performance of the Work, submit to the Departmental Representative, four final copies of operating and maintenance manuals in English.
- .6 Ensure spare parts, maintenance materials and special tools provided are new, undamaged or defective, and of same quality and manufacture as products provided in Work.
- .7 Furnish evidence, if requested, for type, source and quality of products provided.
- .8 Defective products will be rejected, regardless of previous inspections. Replace products at own expense.
- .9 Pay costs of transportation.

1.2 FORMAT

- .1 Organize data as instructional manual.
- .2 Binders: vinyl, hard covered, 3 'D' ring, loose leaf 219 mm x 279 mm with spine and face pockets.
- .3 When multiple binders are used correlate data into related consistent groupings. Identify contents of each binder on spine.
- .4 Cover: identify each binder with type or printed title 'Project Record Documents'; list title of project and identify subject matter of contents.
- .5 Arrange content by systems, process flow, under Section numbers and sequence of Table of Contents.
- .6 Provide tabbed flyleaf for each separate product and system, with typed description of product and major component parts of equipment.
- .7 Text: manufacturer's printed data, or typewritten data.
- .8 Drawings: provide with reinforced punched binder tab. Bind in with text; fold larger drawings to size of text pages.
- .9 Provide 1:1 scaled CAD files in dwg format on CD.

1.3 CONTENTS - EACH VOLUME

- .1 Table of Contents: provide title of project; Date of submission; names.

- .1 Addresses, and telephone numbers of Consultant and Contractor Design-Builder with name of responsible parties.
- .2 Schedule of products and systems, indexed to content of volume.
- .2 For each product or system:
 - .1 List names, addresses and telephone numbers of subcontractors and suppliers, including local source of supplies and replacement parts.
- .3 Product Data: mark each sheet to identify specific products and component parts, and data applicable to installation; delete inapplicable information.
- .4 Drawings: supplement product data to illustrate relations of component parts of equipment and systems, to show control and flow diagrams.

1.4 AS-BUILTS AND SAMPLES

- .1 Maintain, in addition to requirements in General Conditions, at site for Departmental Representative, one (1) record copy of:
 - .1 Contract Drawings.
 - .2 Specifications.
 - .3 Addenda.
 - .4 Change Orders and other modifications to Contract.
 - .5 Reviewed shop drawings, product data, and samples.
 - .6 Field test records.
 - .7 Inspection certificates.
 - .8 Manufacturer's certificates.
- .2 Store record documents and samples in field office apart from documents used for construction. Provide files, racks, and secure storage.
- .3 Label record documents and file in accordance with Section number listings in List of Contents of this Project Manual. Label each document "PROJECT RECORD" in neat, large, printed letters.
- .4 Maintain record documents in clean, dry and legible condition. Do not use record documents for construction purposes.
- .5 Keep record documents and samples available for inspection by Departmental Representative .

1.5 RECORDING ACTUAL SITE CONDITIONS

- .1 Record information on set of drawings, and in copy of Project Manual, provided by Departmental Representative.
- .2 Provide felt tip marking pens, maintaining separate colours for each major system, for recording information.
- .3 Record information concurrently with construction progress. Do not conceal Work until required information is recorded.
- .4 Contract Drawings and shop drawings: mark each item to record actual construction, including:
 - .1 Measured depths of elements of foundation in relation to finish first floor datum.

- .2 Measured horizontal and vertical locations of underground utilities and appurtenances, referenced to permanent surface improvements.
- .3 Measured locations of internal utilities and appurtenances, referenced to visible and accessible features of construction.
- .4 Field changes of dimension and detail.
- .5 Changes made by change orders.
- .6 Details not on original Contract Drawings.
- .7 References to related shop drawings and modifications.
- .5 Specifications: mark each item to record actual construction, including:
 - .1 Manufacturer, trade name, and catalogue number of each product actually installed, particularly optional items and substitute items.
 - .2 Changes made by Addenda and change orders.
- .6 Other Documents: maintain manufacturer's certifications, inspection certifications, field test records, required by individual specifications sections.

1.6 FINAL SURVEY

- .1 Submit final site survey certificate stating that completed works are in conformance, and outlining any agreed non-conforming aspects formally accepted in writing by the Departmental Representative.

1.7 EQUIPMENT AND SYSTEMS

- .1 Each Item of Equipment and Each System: include description of unit or system, and component parts. Give function, normal operation characteristics, and limiting conditions. Include performance curves, with engineering data and tests, and complete nomenclature and commercial number of replaceable parts.
- .2 Panel board circuit directories: provide electrical service characteristics, controls, and communications.
- .3 Include installed colour coded wiring diagrams.
- .4 Operating Procedures: include start-up, break-in, and routine normal operating instructions and sequences. Include regulation, control, stopping, shut-down, and emergency instructions. Include summer, winter, and any special operating instructions.
- .5 Maintenance Requirements: include routine procedures and guide for trouble-shooting; disassembly, repair, and reassembly instructions; and alignment, adjusting, balancing, and checking instructions.
- .6 Provide servicing and lubrication schedule, and list of lubricants required.
- .7 Include manufacturer's printed operation and maintenance instructions.
- .8 Include sequence of operation by controls manufacturer.
- .9 Provide original manufacturer's parts list, illustrations, assembly drawings, and diagrams required for maintenance.
- .10 Provide installed control diagrams by controls manufacturer.
- .11 Provide Contractor's co-ordination drawings, with installed colour coded piping diagrams.
- .12 Provide charts of valve tag numbers, with location and function of each valve, keyed to flow and control diagrams.

- .13 Provide list of original manufacturer's spare parts, current prices, and recommended quantities to be maintained in storage.
- .14 Additional requirements: as specified in individual specification sections.

1.8 MATERIALS AND FINISHES

- .1 Building Products, Applied Materials, and Finishes: include product data, with catalogue number, size, composition, and colour and texture designations. Provide information for re-ordering custom manufactured products.
- .2 Instructions for cleaning agents and methods, precautions against detrimental agents and methods, and recommended schedule for cleaning and maintenance.
- .3 Moisture-Protection and Weather-Exposed Products: include manufacturer's recommendations for cleaning agents and methods, precautions against detrimental agents and methods, and recommended schedule for cleaning and maintenance.
- .4 Additional Requirements: as specified in individual specifications sections.

1.9 WARRANTIES AND BONDS

- .1 Develop warranty management plan to contain information relevant to Warranties.
- .2 Submit warranty management plan, thirty (30) days before planned pre-warranty conference, to Departmental Representative for approval.
- .3 Warranty management plan to include required actions and documents to assure that receives warranties to which it is entitled.
- .4 Provide plan in narrative form and contain sufficient detail to make it suitable for use by future maintenance and repair personnel.
- .5 Submit, warranty information made available during construction phase, to Departmental Representative for approval prior to each monthly pay estimate.
- .6 Assemble approved information in binder and submit upon acceptance of work. Organize binder as follows:
 - .1 Separate each warranty or bond with index tab sheets keyed to Table of Contents listing.
 - .2 List subcontractor, supplier, and manufacturer, with name, address, and telephone number of responsible principal.
 - .3 Obtain warranties and bonds, executed in duplicate by subcontractors, suppliers, and manufacturers, within ten (10) days after completion of applicable item of work.
 - .4 Verify that documents are in proper form, contain full information, and are notarized.
 - .5 Co-execute submittals when required.
 - .6 Retain warranties and bonds until time specified for submittal.
- .7 Except for items put into use with Owner's permission, leave date of beginning of time of warranty until Date of Substantial Performance is determined.
- .8 Conduct joint 4-month and 9-month warranty inspection, measured from time of acceptance by Departmental Representative.
- .9 Include information contained in warranty management plan as follows:

- .1 Roles and responsibilities of personnel associated with warranty process, including points of contact and telephone numbers within the organizations of Contractors, subcontractors, manufacturers or suppliers involved.
- .2 Listing and status of delivery of Certificates of Warranty for extended warranty items, to include pumps, motors, transformers, and commissioned systems such as alarm systems.
- .3 Provide list for each warranted equipment, item, feature of construction or system indicating:
 - .1 Name of item.
 - .2 Model and serial numbers.
 - .3 Location where installed.
 - .4 Name and phone numbers of manufacturers or suppliers.
 - .5 Names, addresses and telephone numbers of sources of spare parts.
 - .6 Warranties and terms of warranty: include one-year overall warranty of construction. Indicate items that have extended warranties and show separate warranty expiration dates.
 - .7 Cross-reference to warranty certificates as applicable.
 - .8 Starting point and duration of warranty period.
 - .9 Summary of maintenance procedures required to continue warranty in force.
 - .10 Cross-Reference to specific pertinent Operation and Maintenance manuals.
 - .11 Organization, names and phone numbers of persons to call for warranty service.
 - .12 Typical response time and repair time expected for various warranted equipment.
- .4 Contractor's plans for attendance at 4 and 9 month post-construction warranty inspections.
- .5 Procedure and status of tagging of equipment covered by extended warranties.
- .6 Post copies of instructions near selected pieces of equipment where operation is critical for warranty and/or safety reasons.
- .10 Respond in a timely manner to oral or written notification of required construction warranty repair work.
- .11 Written verification will follow oral instructions. Failure to respond will be cause for the Departmental Representative to proceed with action against Contractor.

1.10 PRE-WARRANTY CONFERENCE

- .1 Meet with Departmental Representative, to develop understanding of requirements of this section. Schedule meeting prior to contract completion, and at time designated by Departmental Representative.
- .2 Departmental Representative will establish communication procedures for:
 - .1 Notification of construction warranty defects.
 - .2 Determine priorities for type of defect.
 - .3 Determine reasonable time for response.

- .3 Provide name, telephone number and address of licensed and bonded company that is authorized to initiate and pursue construction warranty work action.
- .4 Ensure contact is located within local service area of warranted construction, is continuously available, and is responsive to inquiries for warranty work action.

1.11 WARRANTY TAGS

- .1 Tag, at time of installation, each warranted item. Provide durable, oil and water resistant tag approved by Departmental Representative.
- .2 Attach tags with copper wire and spray with waterproof silicone coating.
- .3 Leave date of acceptance until project is accepted for occupancy.
- .4 Indicate following information on tag:
 - .1 Type of product/material.
 - .2 Model number.
 - .3 Serial number.
 - .4 Contract number.
 - .5 Warranty period.
 - .6 Inspector's signature.
 - .7 Construction Contractor.

Part 2 Products

2.1 NOT USED

- .1 Not Used.

Part 3 Execution

3.1 NOT USED

- .1 Not Used.

END OF SECTION

Part 1 General

1.1 SUMMARY

- .1 Section Includes:
 - .1 General requirements relating to commissioning of project's components and systems, specifying general requirements to PV of components, equipment, sub-systems, systems, and integrated systems.
 - .2 Acronyms:
 - .1 AFD - Alternate Forms of Delivery, service provider.
 - .2 BMM - Building Management Manual.
 - .3 Cx - Commissioning.
 - .4 EMCS - Energy Monitoring and Control Systems.
 - .5 O&M - Operation and Maintenance.
 - .6 PI - Product Information.
 - .7 PV - Performance Verification.
 - .8 TAB - Testing, Adjusting and Balancing.

1.2 GENERAL

- .1 Cx is a planned program of tests, procedures and checks carried out systematically on systems and integrated systems of the finished Project. Cx is performed after systems and integrated systems are completely installed, functional and Contractor's Performance Verification responsibilities have been completed and approved. Objectives:
 - .1 Verify installed equipment, systems and integrated systems operate in accordance with contract documents and design criteria and intent.
 - .2 Ensure appropriate documentation is compiled into the BMM.
 - .3 Effectively train O&M staff.
- .2 Contractor assists in Cx process, operating equipment and systems, troubleshooting, and making adjustments as required.
 - .1 Systems to be operated at full capacity under various modes to determine if they function correctly and consistently at peak efficiency. Systems to be used interactively with each other as intended in accordance with Contract Documents and design criteria.
 - .2 During these checks, adjustments to be made to enhance performance to meet environmental or user requirements.
- .3 Design Criteria: as per client's requirements or determined by designer. To meet Project functional and operational requirements.
- .4 For AFD-managed projects, the term Departmental Representative in Cx specifications to be interpreted as AFD Service Provider.

1.3 COMMISSIONING OVERVIEW

- .1 Cx to be a line item of Contractor's cost breakdown.
- .2 Cx activities supplement field quality and testing procedures described in relevant technical sections.

-
- .3 Cx is conducted in concert with activities performed during stage of project delivery. Cx identifies issues in Planning and Design stages which are addressed during Construction and Cx stages to ensure the built facility is constructed and proven to operate satisfactorily under weather, environmental, and occupancy conditions to meet functional and operational requirements. Cx activities include transfer of critical knowledge to facility operational personnel.
 - .4 Departmental Representative will issue Interim Acceptance Certificate when:
 - .1 Completed Cx documentation has been received, reviewed for suitability and approved by Departmental Representative.
 - .2 Equipment, components, and systems have been commissioned.
 - .3 O&M training has been completed.

1.4 NON-CONFORMANCE TO PERFORMANCE VERIFICATION REQUIREMENTS

- .1 Should equipment, system components, and associated controls be incorrectly installed or malfunction during Cx, correct deficiencies, re-verify equipment and components within the non-functional system, including related systems as deemed required by Departmental Representative to ensure effective performance.
- .2 Costs for corrective work, additional tests, inspections, to determine acceptability and proper performance of such items to be borne by Contractor. Above costs to be in form of progress payment reductions or hold-back assessments.

1.5 PRE-CX REVIEW

- .1 Before Construction:
 - .1 Review contract documents, confirm by writing to Departmental Representative.
 - .1 Adequacy of provisions for Cx.
 - .2 Aspects of design and installation pertinent to success of Cx.
- .2 During Construction:
 - .1 Co-ordinate provision, location and installation of provisions for Cx.
- .3 Before start of Cx:
 - .1 Have completed Cx Plan up-to-date.
 - .2 Ensure installation of related components, equipment, sub-systems, systems is complete.
 - .3 Fully understand Cx requirements and procedures.
 - .4 Have Cx documentation shelf-ready.
 - .5 Understand completely design criteria and intent and special features.
 - .6 Submit complete start-up documentation to Departmental Representative.
 - .7 Have Cx schedules up-to-date.
 - .8 Ensure systems have been cleaned thoroughly.
 - .9 Complete TAB procedures on systems, submit TAB reports to Departmental Representative for review and approval.
 - .10 Ensure "As-Built" system schematics are available.
- .4 Inform Departmental Representative in writing of discrepancies and deficiencies on finished works.

1.6 CONFLICTS

- .1 Report conflicts between requirements of this section and other sections to Departmental Representative before start-up and obtain clarification.
- .2 Failure to report conflict and obtain clarification will result in application of most stringent requirement.

1.7 SUBMITTALS

- .1
 - .1 Submit no later than four (4) weeks after award of Contract:
 - .1 Name of Contractor's Cx agent.
 - .2 Draft Cx documentation.
 - .3 Preliminary Cx schedule.
 - .2 Request in writing to Departmental Representative for changes to submittals and obtain written approval at least eight (8) weeks prior to start of Cx.
 - .3 Submit proposed Cx procedures to Departmental Representative where not specified and obtain written approval at least eight (8) weeks prior to start of Cx.
 - .4 Provide additional documentation relating to Cx process as required by[Departmental Representative.

1.8 COMMISSIONING DOCUMENTATION

- .1 Refer to Section 01 91 33 - Commissioning (Cx) Forms: Installation Check Lists and Product Information (PI) / Performance Verification (PV) Forms for requirements and instructions for use.
- .2 Departmental Representative to review and approve Cx documentation.
- .3 Provide completed and approved Cx documentation to Departmental Representative.

1.9 COMMISSIONING SCHEDULE

- .1 Provide detailed Cx schedule as part of construction schedule.
- .2 Provide adequate time for Cx activities prescribed in technical sections and commissioning sections including:
 - .1 Approval of Cx reports.
 - .2 Verification of reported results.
 - .3 Repairs, retesting, re-commissioning, re-verification.
 - .4 Training.

1.10 COMMISSIONING MEETINGS

- .1 Convene Cx meetings following project meetings.
- .2 Purpose: To resolve issues, monitor progress, and identify deficiencies relating to Cx.
- .3 Continue Cx meetings on regular basis until commissioning deliverables have been addressed.
- .4 At 60% construction completion stage, Departmental Representative to call a separate Cx scope meeting to review progress, discuss schedule of equipment start-up activities, and prepare for Cx. Issues at meeting to include:

-
- .1 Review duties and responsibilities of Contractor and subcontractors, addressing delays and potential problems.
 - .2 Determine the degree of involvement of trades and manufacturer's representatives in the commissioning process.
 - .5 Thereafter, Cx meetings to be held until project completion and as required during equipment start-up and functional testing period.
 - .6 Meeting will be chaired by Departmental Representative, who will record and distribute minutes.
 - .7 Ensure subcontractors and relevant manufacturer representatives are present at 60% and subsequent Cx meetings and as required.

1.11 STARTING AND TESTING

- .1 Contractor assumes liabilities and costs for inspections. Including disassembly and re-assembly after approval, starting, testing and adjusting, including supply of testing equipment.

1.12 WITNESSING OF STARTING AND TESTING

- .1 Provide fourteen (14) days notice prior to commencement.
- .2 Departmental Representative to witness of start-up and testing.
- .3 .3 Contractor's Cx Agent to be present at tests performed and documented by sub-trades, suppliers and equipment manufacturers.

1.13 MANUFACTURER'S INVOLVEMENT

- .1 Not used.

1.14 PROCEDURES

- .1 Verify that equipment and systems are complete, clean, and operating in normal and safe manner prior to conducting start-up, testing and Cx.
- .2 Conduct start-up and testing in following distinct phases:
 - .1 Included in delivery and installation:
 - .1 Verification of conformity to specification, approved shop drawings and completion of PI report forms.
 - .2 Visual inspection of quality of installation.
 - .2 Start-up: follow accepted start-up procedures.
 - .3 Operational testing: document equipment performance.
 - .4 System PV: include repetition of tests after correcting deficiencies.
 - .5 Post-substantial performance verification: to include fine-tuning.
- .3 Correct deficiencies and obtain approval from Departmental Representative after distinct phases have been completed and before commencing next phase.
- .4 Document require tests on approved PV forms.
- .5 Failure to follow accepted start-up procedures will result in re-evaluation of equipment by an independent testing agency selected by Departmental Representative. If results reveal that equipment start-up was not in accordance with requirements, and resulted in damage to equipment, implement following:

- .1 Minor equipment/systems: implement corrective measures approved by Departmental Representative.
- .2 Major equipment/systems: if evaluation report concludes that damage is minor, implement corrective measures approved by Departmental Representative.
- .3 If evaluation report concludes that major damage has occurred, Departmental Representative shall reject equipment.
 - .1 Rejected equipment to be removed from site and replace with new.
 - .2 Subject new equipment/systems to specified start-up procedures.

1.15 START-UP DOCUMENTATION

- .1 Assemble start-up documentation and submit to Departmental Representative for approval before commencement of commissioning.
- .2 Start-up documentation to include:
 - .1 Factory and on-site test certificates for specified equipment.
 - .2 Pre-start-up inspection reports.
 - .3 Signed installation/start-up check lists.
 - .4 Start-up reports,
 - .5 Step-by-step description of complete start-up procedures, to permit Departmental Representative to repeat start-up at any time.

1.16 OPERATION AND MAINTENANCE OF EQUIPMENT AND SYSTEMS

- .1 After start-up, operate and maintain equipment and systems as directed by equipment/system manufacturer.
- .2 With assistance of manufacturer, develop written maintenance program and submit to Departmental Representative for approval before implementation.
- .3 Operate and maintain systems for length of time required for commissioning to be completed.
- .4 After completion of commissioning, operate and maintain systems until issuance of certificate of interim acceptance.

1.17 TEST RESULTS

- .1 If start-up, testing and/or PV produce unacceptable results, repair, replace or repeat specified starting and/or PV procedures until acceptable results are achieved.
- .2 Provide manpower and materials, assume costs for re-commissioning.

1.18 START OF COMMISSIONING

- .1 Notify Departmental Representative at least twenty-one (21) days prior to start of Cx.
- .2 Start Cx after elements of building affecting start-up and performance verification of systems have been completed.

1.19 INSTRUMENTS / EQUIPMENT

- .1 Submit to Departmental Representative for review and approval:
 - .1 Complete list of instruments proposed to be used.

.2 Listed data including, serial number, current calibration certificate, calibration date, calibration expiry date and calibration accuracy.

.2 Provide the following equipment as required.

1.20 COMMISSIONING PERFORMANCE VERIFICATION

.1 Carry out Cx:

.1 Under actual operating conditions, over entire operating range, in all modes.

.2 On independent systems and interacting systems.

.2 Cx procedures to be repeatable and reported results are to be verifiable.

.3 Follow equipment manufacturer's operating instructions.

.4 EMCS trending to be available as supporting documentation for performance verification.

1.21 WITNESSING COMMISSIONING

.1 Departmental Representative to witness activities and verify results.

1.22 AUTHORITIES HAVING JURISDICTION

.1 Where specified start-up, testing, or commissioning procedures duplicate verification requirements of authority having jurisdiction, arrange for authority to witness procedures so as to avoid duplication of tests and to facilitate expedient acceptance of facility.

.2 Obtain certificates of approval, acceptance and compliance with rules and regulation of authority having jurisdiction.

.3 Provide copies to Departmental Representative within ten (10) days of test and with Cx report.

1.23 COMMISSIONING CONSTRAINTS

.1 Not used.

1.24 EXTRAPOLATION OF RESULTS

.1 Where Cx of weather, occupancy, or seasonal-sensitive equipment or systems cannot be conducted under near-rated or near-design conditions, extrapolate part-load results to design conditions when approved by Departmental Representative in accordance with equipment manufacturer's instructions, using manufacturer's data, with manufacturer's assistance and using approved formulae.

1.25 EXTENT OF VERIFICATION

.1 Number and location to be at discretion of Departmental Representative.

.2 Conduct tests repeated during verification under same conditions as original tests, using same test equipment, instrumentation.

.3 Review and repeat commissioning of systems if inconsistencies found in more than 20% of reported results.

.4 Perform additional commissioning until results are acceptable to Departmental Representative.

1.26 REPEAT VERIFICATIONS

- .1 Assume costs incurred by Departmental Representative for third and subsequent verifications where:
 - .1 Verification of reported results fail to receive Departmental Representative's approval.
 - .2 Repetition of second verification again fails to receive approval.
 - .3 Departmental Representative deems Contractor's request for second verification was premature.

1.27 SUNDRY CHECKS AND ADJUSTMENTS

- .1 Make adjustments and changes that become apparent as Cx proceeds.
- .2 Perform static and operational checks as applicable and as required.

1.28 DEFICIENCIES, FAULTS, DEFECTS

- .1 Correct deficiencies found during start-up and Cx to satisfaction of Departmental Representative.
- .2 Report problems, faults, or defects affecting Cx to Departmental Representative in writing. Stop Cx until problems are rectified. Proceed with written approval from Departmental Representative.

1.29 COMPLETION OF COMMISSIONING

- .1 Upon completion of Cx leave systems in normal operating mode.
- .2 Except for warranty and seasonal verification activities specified in Cx specifications, complete Cx prior to issuance of Interim Certificate of Completion.
- .3 Cx to be considered complete when contract Cx deliverables have been submitted and accepted by Departmental Representative.

1.30 ACTIVITIES UPON COMPLETION OF COMMISSIONING

- .1 When changes are made to baseline components or system settings established during Cx process, provide updated Cx form for affected item.

1.31 TRAINING

- .1 Not used.

1.32 MAINTENANCE MATERIALS, SPARE PARTS, SPECIAL TOOLS

- .1 Supply, deliver, and document maintenance materials, spare parts, and special tools as specified in contract.

1.33 OCCUPANCY

- .1 Cooperate fully with Departmental Representative during stages of acceptance and occupancy of facility.

1.34 INSTALLED INSTRUMENTATION

- .1 Use instruments installed under Contract for TAB and PV if:
 - .1 Accuracy complies with these specifications.

- .2 Calibration certificates have been deposited with Departmental Representative.
- .2 Calibrated EMCS sensors may be used to obtain performance data provided that sensor calibration has been completed and accepted.

1.35 PERFORMANCE VERIFICATION TOLERANCES

- .1 Application tolerances:
 - .1 Specified range of acceptable deviations of measured values from specified values or specified design criteria. Except for special areas, to be within +/- 10% of specified values.
- .2 Instrument accuracy tolerances:
 - .1 To be of higher order of magnitude than equipment or system being tested.
- .3 Measurement tolerances during verification:
 - .1 Unless otherwise specified actual values to be within +/- 2% of recorded values.

1.36 OWNER'S PERFORMANCE TESTING

- .1 Performance testing of equipment or system by Departmental Representative will not relieve Contractor from compliance with specified start-up and testing procedures.

Part 2 Products

2.1 NOT USED

- .1 Not Used.

Part 3 Execution

3.1 NOT USED

- .1 Not Used.

END OF SECTION

Part 1 General

1.1 SUMMARY

- .1 Section Includes:
 - .1 Commissioning forms to be completed for equipment, system, and integrated system.

1.2 INSTALLATION/START-UP CHECK LISTS

- .1 Include the following data:
 - .1 Product manufacturer's installation instructions and recommended checks.
 - .2 Special procedures as specified in relevant technical sections.
 - .3 Items considered good installation and engineering industry practices deemed appropriate for proper and efficient operation.
- .2 Equipment manufacturer's installation/start-up checklists are acceptable for use. As deemed necessary by Departmental Representative, supplemental additional data lists will be required for specific project conditions.
- .3 Use check lists for equipment installation. Document checklist verifying checks have been made; indicate deficiencies and corrective action taken.
- .4 Installer to sign check lists upon completion, certifying stated checks and inspections have been performed. Return completed check lists to Departmental Representative. Check lists will be required during Commissioning and will be included in Building Maintenance Manual (BMM) at completion of project.
- .5 Use of check lists will not be considered part of commissioning process but will be stringently used for equipment pre-start and start-up procedures.

1.3 PRODUCT INFORMATION (PI) REPORT FORMS

- .1 Product Information (PI) forms compiles gathered data on items of equipment produced by equipment manufacturer, includes nameplate information, parts list, operating instructions, maintenance guidelines and pertinent technical data and recommended checks that is necessary to prepare for start-up and functional testing and used during operation and maintenance of equipment. This documentation is included in the BMM at completion of work.
- .2 Prior to Performance Verification (PV) of systems complete items on PI forms related to systems and obtain Departmental Representative's approval.

1.4 PERFORMANCE VERIFICATION (PV) FORMS

- .1 PV forms to be used for checks, running dynamic tests and adjustments carried out on equipment and systems to ensure correct operation, efficiently and function independently and interactively with other systems as intended with project requirements.
- .2 PV report forms include those developed by Contractor records measured data and readings taken during functional testing and Performance Verification procedures.
- .3 Prior to PV of integrated system, complete PV forms of related systems and obtain Departmental Representative's approval.

1.5 SAMPLES OF COMMISSIONING FORMS

- .1 Not used

1.6 CHANGES AND DEVELOPMENT OF NEW REPORT FORMS

- .1 When additional forms are required, but are not available from Departmental Representative, develop appropriate verification forms and submit to Departmental Representative for approval prior to use.
 - .1 Additional commissioning forms to be in same format as provided by Departmental Representative.

1.7 COMMISSIONING FORMS

- .1 Use Commissioning forms to verify installation and record performance when starting equipment and systems.
- .2 Strategy for Use:
 - .1 Departmental Representative may provide Contractor with project-specific Commissioning forms with Specification data included.
 - .2 Contractor will provide required shop drawings information and verify correct installation and operation of items indicated on these forms.
 - .3 Confirm operation as per design criteria and intent.
 - .4 Identify variances between design and operation and reasons for variances.
 - .5 Verify operation in specified normal and emergency modes and under specified load conditions.
 - .6 Record analytical and substantiating data.
 - .7 Verify reported results.
 - .8 Form to bear signatures of recording technician and reviewed and signed off by Departmental Representative.
 - .9 Submit immediately after tests are performed.
 - .10 Reported results in true measured SI unit values.
 - .11 Provide Departmental Representative with originals of completed forms.
 - .12 Maintain copy on site during start-up, testing and commissioning period.
 - .13 Forms to be both hard copy and electronic format with typed-written results in Building Management Manual.

1.8 LANGUAGE

- .1 To suit the language profile of the awarded contract.

Part 2 Products

2.1 NOT USED

- .1 Not Used.

Part 3 Execution

3.1 NOT USED

.1 Not Used.

END OF SECTION

Part 1 General

1.1 REFERENCES

- .1 Export and Import of Hazardous Waste Regulations SOR/2002-300.
- .2 National Fire Code of Canada 2005.
- .3 Transportation of Dangerous Goods Act (TDG Act) 1999, (c. 34).
- .4 Transportation of Dangerous Goods Regulations (T-19.01-SOR/2003-400).

1.2 DEFINITIONS

- .1 Dangerous Goods: product, substance, or organism that is specifically listed or meets hazard criteria established in Transportation of Dangerous Goods Regulations.
- .2 Hazardous Material: product, substance, or organism that is used for its original purpose; and that is either dangerous goods or a material that may cause adverse impact to environment or adversely affect health of persons, animals, or plant life when released into the environment.
- .3 Hazardous Waste: any hazardous material that is no longer used for its original purpose and that is intended for recycling, treatment or disposal.
- .4 Workplace Hazardous Materials Information System (WHMIS): a Canada-wide system designed to give employers and workers information about hazardous materials used in workplace. Under WHMIS, information on hazardous materials is provided on container labels, material safety data sheets (MSDS), and worker education programs. WHMIS is put into effect by combination of federal and provincial laws.

1.3 SUBMITTALS

- .1 Submit product data in accordance with Section 01 33 00 - Submittal Procedures.
- .2 Submit to Departmental Representative current Material Safety Data Sheet (MSDS) for each hazardous material required prior to bringing hazardous material on site.
- .3 Submit hazardous materials management plan to Departmental Representative identifies hazardous materials, their use, their location, personal protective equipment requirements, and disposal arrangements.

1.4 STORAGE AND HANDLING

- .1 Co-ordinate storage of hazardous materials with Departmental Representative abide by internal requirements for labelling and storage of materials and wastes.
- .2 Store and handle hazardous materials and wastes in accordance with applicable federal and provincial laws, regulations, codes, and guidelines.
- .3 Store and handle flammable and combustible materials in accordance with current National Fire Code of Canada requirements.
- .4 Keep no more than forty-five (45) litres of flammable and combustible liquids such as gasoline, kerosene and naphtha for ready use.
 - .1 Store flammable and combustible liquids in approved safety cans bearing the Underwriters' Laboratory of Canada or Factory Mutual seal of approval.

-
- .2 Storage of quantities of flammable and combustible liquids exceeding forty-five (45) litres for work purposes requires the written approval of the Departmental Representative.
 - .5 Transfer of flammable and combustible liquids is prohibited within buildings.
 - .6 Do not transfer of flammable and combustible liquids in vicinity of open flames or heat-producing devices.
 - .7 Do not use flammable liquids having flash point below thirty-eight (38) degrees Celsius, such as naphtha or gasoline as solvents or cleaning agents.
 - .8 Store flammable and combustible waste liquids for disposal in approved containers located in safe, ventilated area. Keep quantities to minimum.
 - .9 Observe smoking regulations, smoking is prohibited in areas where hazardous materials are stored, used, or handled.
 - .10 Storage requirements for quantities of hazardous materials and wastes in excess of five (5) kg for solids, and five (5) litres for liquids:
 - .1 Store hazardous materials and wastes in closed and sealed containers.
 - .2 Label containers of hazardous materials and wastes in accordance with WHMIS.
 - .3 Store hazardous materials and wastes in containers compatible with that material or waste.
 - .4 Segregate incompatible materials and wastes.
 - .5 Ensure that different hazardous materials or hazardous wastes are not mixed.
 - .6 Store hazardous materials and wastes in secure storage area with controlled access.
 - .7 Maintain clear egress from storage area.
 - .8 Store hazardous materials and wastes in location that will prevent them from spilling into environment.
 - .9 Have appropriate emergency spill response equipment available near storage area, including personal protective equipment.
 - .10 Maintain inventory of hazardous materials and wastes, including product name, quantity, and date when storage began.
 - .11 Ensure personnel have been trained in accordance with Workplace Hazardous Materials Information System (WHMIS) requirements. Report spills or accidents immediately to Departmental Representative. Submit a written spill report to Departmental Representative within 24 hours of incident.

1.5 TRANSPORTATION

- .1 Transport hazardous materials and wastes in accordance with federal Transportation of Dangerous Goods Act, Transportation of Dangerous Goods Regulations, and applicable provincial regulations.
- .2 If exporting hazardous waste to another country, ensure compliance with federal Export and Import of Hazardous Waste Regulations.
- .3 If hazardous waste is generated on site:
 - .1 Co-ordinate transportation and disposal with Departmental Representative.
 - .2 Ensure compliance with applicable federal, provincial and municipal laws and regulations for generators of hazardous waste.

- .3 Use licensed carrier authorized by provincial authorities to accept subject material.
- .4 Prior to shipping material obtain written notice from intended hazardous waste treatment or disposal facility that it will accept material and that it is licensed to accept this material.
- .5 Label containers with legible, visible safety marks as prescribed by federal and provincial regulations.
- .6 Ensure that trained personnel handle, offer for transport, or transport dangerous goods.
- .7 Provide photocopy of shipping documents and waste manifests to Departmental Representative.
- .8 Track receipt of completed manifest from consignee after shipping dangerous goods. Provide a photocopy of completed manifest to Departmental Representative.
- .9 Report discharge, emission, or escape of hazardous materials immediately to Departmental Representative and appropriate provincial authority. Take reasonable measures to control release.

Part 2 Products

2.1 MATERIALS

- .1 Only bring on site quantity of hazardous materials required to perform work.
- .2 Maintain MSDSs in proximity to where materials are being used. Communicate this location to personnel who may have contact with hazardous materials.

Part 3 Execution

3.1 DISPOSAL

- .1 Dispose of hazardous waste materials in accordance with applicable federal and provincial acts, regulations, and guidelines.
- .2 Recycle hazardous wastes for which there is approved, cost effective recycling process available.
- .3 Send hazardous wastes to authorized hazardous waste disposal or treatment facilities.
- .4 Burning, diluting, or mixing hazardous wastes for purpose of disposal is prohibited.
- .5 Disposal of hazardous materials in waterways, storm or sanitary sewers, or in municipal solid waste landfills is prohibited.
- .6 Dispose of hazardous wastes in timely fashion in accordance with applicable provincial regulations.
- .7 Minimize generation of hazardous waste to maximum extent practicable. Take necessary precautions to avoid mixing clean and contaminated wastes.
- .8 Identify and evaluate recycling and reclamation options as alternatives to land disposal, such as:
 - .1 Hazardous wastes recycled in manner constituting disposal.
 - .2 Hazardous waste burned for energy recovery.

- .3 Lead-acid battery recycling.
- .4 Hazardous wastes with economically recoverable precious metals.

END OF SECTION

Part 1 General

1.1 SUBMITTALS

- .1 Submittals: in accordance with Section 01 33 00 - Submittal Procedures.
- .2 Shop drawings to show:
 - .1 Mounting arrangements.
 - .2 Operating and maintenance clearances.
- .3 Shop drawings and product data accompanied by:
 - .1 Detailed drawings of bases, supports, and anchor bolts.
 - .2 Acoustical sound power data, where applicable.
 - .3 Points of operation on performance curves.
 - .4 Manufacturer to certify current model production.
 - .5 Certification of compliance to applicable codes.
- .4 In addition to transmittal letter referred to in Section 01 33 00 - Submittal Procedures: use MCAC "Shop Drawing Submittal Title Sheet". Identify section and paragraph number.
- .5 Closeout Submittals:
 - .1 Provide operation and maintenance data for incorporation into manual specified in Section 01 78 00 - Closeout Submittals.
 - .2 Operation and maintenance manual approved by, and final copies deposited with, Departmental Representative before final inspection.
 - .3 Operation data to include:
 - .1 Control schematics for systems including environmental controls.
 - .2 Description of systems and their controls.
 - .3 Description of operation of systems at various loads together with reset schedules and seasonal variances.
 - .4 Operation instruction for systems and component.
 - .5 Description of actions to be taken in event of equipment failure.
 - .6 Valves schedule and flow diagram.
 - .7 Colour coding chart.
 - .4 Maintenance data to include:
 - .1 Servicing, maintenance, operation and trouble-shooting instructions for each item of equipment.
 - .2 Data to include schedules of tasks, frequency, tools required and task time.
 - .5 Performance data to include:
 - .1 Equipment manufacturer's performance datasheets with point of operation as left after commissioning is complete.
 - .2 Equipment performance verification test results.
 - .3 Special performance data as specified.
 - .4 Testing, adjusting and balancing reports as specified in Section 23 05 93 - Testing, Adjusting and Balancing for HVAC.

- .6 Approvals:
 - .1 Submit two (2) copies of draft Operation and Maintenance Manual to Departmental Representative for approval. Submission of individual data will not be accepted unless directed by Departmental Representative.
 - .2 Make changes as required and re-submit as directed by Departmental Representative .
- .7 Additional data:
 - .1 Prepare and insert into operation and maintenance manual additional data when need for it becomes apparent during specified demonstrations and instructions.
- .8 Site records:
 - .1 Departmental Representative will provide one (1) set of reproducible mechanical drawings. Provide sets of white prints as required for each phase of work. Mark changes as work progresses and as changes occur. Include changes to existing mechanical systems, control systems and low voltage control wiring.
 - .2 Transfer information weekly to reproducibles, revising reproducibles to show work as actually installed.
 - .3 Use different colour waterproof ink for each service.
 - .4 Make available for reference purposes and inspection.
- .9 As-built drawings:
 - .1 Prior to start of Testing, Adjusting and Balancing for HVAC, finalize production of as-built drawings.
 - .2 Identify each drawing in lower right hand corner in letters at least 12 mm high as follows: - "AS BUILT DRAWINGS: THIS DRAWING HAS BEEN REVISED TO SHOW MECHANICAL SYSTEMS AS INSTALLED" (Signature of Contractor) (Date).
 - .3 Submit to Departmental Representative for approval and make corrections as directed.
 - .4 Perform testing, adjusting and balancing for HVAC using as-built drawings.
 - .5 Submit completed reproducible as-built drawings with Operating and Maintenance Manuals.
- .10 Submit copies of as-built drawings for inclusion in final TAB report.

1.2 MAINTENANCE

- .1 Furnish spare parts in accordance with Section 01 78 00 - Closeout Submittals.

Part 2 Products

2.1 NOT USED

Part 3 Execution

3.1 CLEANING

- .1 Clean interior and exterior of all systems including strainers. Vacuum interior of ductwork.

3.2 DEMONSTRATION

- .1 Departmental Representative will use equipment and systems for test purposes prior to acceptance. Supply labour, material, and instruments required for testing.
- .2 Trial usage to apply to following equipment and systems:
 - .1 Exhaust fan.
 - .2 Forced air unit heater.
- .3 Supply tools, equipment and personnel to demonstrate and instruct operating and maintenance personnel in operating, controlling, adjusting, trouble-shooting and servicing of all systems and equipment during regular work hours, prior to acceptance.
- .4 Use operation and maintenance manual, as-built drawings, and audio visual aids as part of instruction materials.
- .5 Instruction duration time requirements as specified in appropriate sections.
- .6 Departmental Representative may record these demonstrations on video tape for future reference.

3.3 PROTECTION

- .1 Protect equipment and systems openings from dirt, dust, and other foreign materials with materials appropriate to system.

END OF SECTION

Part 1 General

1.1 SUMMARY

- .1 Section Includes:
 - .1 Materials and requirements for the identification of piping systems, ductwork, valves, and controllers, including the installation and location of identification systems.

1.2 REFERENCES

- .1 Canadian General Standards Board (CGSB)
 - .1 CAN/CGSB-24.3-92 Identification of Piping Systems.

1.3 SUBMITTALS

- .1 Product Data:
- .2 Submittals: in accordance with Section 01 33 00 - Submittal Procedures.

Part 2 Products

2.1 MANUFACTURER'S EQUIPMENT NAMEPLATES

- .1 Metal or plastic laminate nameplate mechanically fastened to each piece of equipment by manufacturer.
- .2 Lettering and numbers raised or recessed.
- .3 Information to include, as appropriate:
 - .1 Equipment: manufacturer's name, model, size, serial number, capacity.
 - .2 Motor: voltage, Hz, phase, power factor, duty, frame size.

2.2 SYSTEM NAMEPLATES

- .1 Colours:
 - .1 Hazardous: red letters, white background.
 - .2 Elsewhere: black letters, white background (except where required otherwise by applicable codes).
- .2 Construction:
 - .1 3 mm thick laminated plastic or white anodized aluminum, matte finish, with square corners, letters accurately aligned and machine engraved into core.
- .3 Sizes:

- .1 Conform to following table:

Size # mm	Sizes (mm)	No. of Lines	Height of Letters (mm)
1	10 x 50	1	3
2	13 x 75	1	5
3	13 x 75	2	3
4	20 x 100	1	8

Size # mm	Sizes (mm)	No. of Lines	Height of Letters (mm)
5	20 x 100	2	5
6	20 x 200	1	8
7	25 x 125	1	12
8	25 x 125	2	8
9	35 x 200	1	20

.2 Use maximum of 25 letters/numbers per line.

.4 Locations:

.1 Terminal cabinets, control panels: use size # 5 .

.2 Equipment in Mechanical Rooms: use size # 9 .

.5 Identification for PWGSC Preventive Maintenance Support System (PMSS):

.1 Use arrangement of Main identifier, Source identifier, Destination identifier.

.2 Equipment in Mechanical Room:

.1 Main identifier: size #9.

.2 Source and Destination identifiers: size #6.

.3 Terminal cabinets, control panels: size #5.

.3 Equipment elsewhere: sizes as appropriate.

2.3 EXISTING IDENTIFICATION SYSTEMS

.1 Apply existing identification system to new work.

.2 Where existing identification system does not cover for new work, use identification system specified this section.

.3 Before starting work, obtain written approval of identification system from Departmental Representative.

IDENTIFICATION OF PIPING SYSTEMS

.4 Identify contents by background colour marking, pictogram (as necessary), legend; direction of flow by arrows. To CAN/CGSB 24.3 except where specified otherwise.

.5 Pictograms:

.1 Where required: Workplace Hazardous Materials Information System (WHMIS) regulations.

.6 Legend:

.1 Block capitals to sizes and colours listed in CAN/CGSB 24.3.

.7 Arrows showing direction of flow:

.1 Outside diameter of pipe or insulation less than 75 mm: 100 mm long x 50 mm high.

.2 Outside diameter of pipe or insulation 75 mm and greater: 150 mm long x 50 mm high.

.3 Use double-headed arrows where flow is reversible.

.8 Extent of background colour marking:

.1 To full circumference of pipe or insulation.

- .2 Length to accommodate pictogram, full length of legend and arrows.
- .9 Materials for background colour marking, legend, arrows:
 - .1 Pipes and tubing 20 mm and smaller: waterproof and heat-resistant pressure sensitive plastic marker tags.
 - .2 Other pipes: pressure sensitive plastic-coated cloth vinyl with protective overcoating, waterproof contact adhesive undercoating, suitable for ambient of 100% RH and continuous operating temperature of 150 degrees C and intermittent temperature of 200 degrees C.

.10 Colours and Legends:

- .1 Where not listed, obtain direction from the Departmental Representative.
- .2 Colours for legends, arrows: to following table:

Background colour:	Legend, arrows:
Yellow	BLACK
Green	WHITE
Red	WHITE

- .3 Background colour marking and legends for piping systems:

Contents	Background colour marking	Legend
** Add design temperature		
++ Add design temperature and pressure		
Domestic cold water supply	Green	DOM. CWS
Sanitary	Green	SAN
Plumbing vent	Green	SAN. VENT
Fire protection water	Red	FIRE PROT. WTR

2.4 IDENTIFICATION DUCTWORK SYSTEMS

- .1 50 mm high stencilled letters and directional arrows 150 mm long x 50 mm high.
- .2 Colours: back, or co-ordinated with base colour to ensure strong contrast.

2.5 VALVES, CONTROLLERS

- .1 Brass tags with 12 mm stamped identification data filled with black paint.
- .2 Include flow diagrams for each system, of approved size, showing charts and schedules with identification of each tagged item, valve type, service, function, normal position, location of tagged item.

2.6 CONTROLS COMPONENTS IDENTIFICATION

- .1 Identify all systems, equipment, components, controls, and sensors with system nameplates specified in this section.
- .2 Inscriptions to include function and (where appropriate) fail-safe position.

2.7 LANGUAGE

- .1 Identification in English and French.

Part 3 Execution

3.1 MANUFACTURER'S INSTRUCTIONS

- .1 Compliance: comply with manufacturer's written recommendations or specifications, including product technical bulletins, handling, storage and installation instructions, and datasheet.

3.2 INSTALLATION

- .1 Perform work in accordance with CAN/CGSB-24.3 except as specified otherwise.
- .2 Provide ULC and or CSA registration plates as required by respective agency.
- .3 Identify systems, equipment to conform to PWGSC Preventive Maintenance Support System (PMSS).

3.3 NAMEPLATES

- .1 Locations:
 - .1 In conspicuous location to facilitate easy reading and identification from operating floor.
- .2 Standoffs:
 - .1 Provide for nameplates on hot and/or insulated surfaces.
- .3 Protection:
 - .1 Do not paint, insulate or cover.

3.4 LOCATION OF IDENTIFICATION ON PIPING AND DUCTWORK SYSTEMS

- .1 On long straight runs in open areas in boiler rooms, equipment rooms, galleries, tunnels: at not more than 17 m intervals and more frequently if required to ensure that at least one is visible from any one viewpoint in operating areas and walking aisles.
- .2 Adjacent to each change in direction.
- .3 At least once in each small room through which piping or ductwork passes.
- .4 On both sides of visual obstruction or where run is difficult to follow.
- .5 On both sides of separations such as walls, floors, partitions.
- .6 Where system is installed in pipe chases, ceiling spaces, galleries, confined spaces, at entry and exit points, and at access openings.
- .7 At beginning and end points of each run and at each piece of equipment in run.
- .8 At point immediately upstream of major manually operated or automatically controlled valves, and dampers. Where this is not possible, place identification as close as possible, preferably on upstream side.
- .9 Identification easily and accurately readable from usual operating areas and from access points.
 - .1 Position of identification approximately at right angles to most convenient line of sight, considering operating positions, lighting conditions, risk of physical damage or injury and reduced visibility over time due to dust and dirt.

3.5 VALVES, CONTROLLERS

- .1 Valves and operating controllers, except at plumbing fixtures, radiation, or where in plain sight of equipment they serve: Secure tags with non-ferrous chains or closed "S" hooks.
- .2 Install one copy of flow diagrams and valve schedules mounted in a frame behind non-glare glass where directed by the Departmental Representative. Provide one copy (reduced in size if required) in each operating and maintenance manual.
- .3 Number valves in each system consecutively.

3.6 CLEANING

- .1 Proceed in accordance with Section 01 74 11 - Cleaning.
- .2 Upon completion and verification of performance of installation, remove surplus materials, excess materials, rubbish, tools and equipment.

END OF SECTION

Part 1 General

1.1 SUMMARY

- .1 TAB is used throughout this Section to describe the process, methods and requirements of testing, adjusting and balancing for hydronic systems.
- .2 TAB means to test, adjust and balance to perform in accordance with requirements of Contract Documents and to do other work as specified in this section.

1.2 QUALIFICATIONS OF TAB PERSONNEL

- .1 Submit names of personnel to perform TAB to Departmental Representative within ninety (90) days of award of contract.
- .2 Provide documentation confirming qualifications, successful experience.
- .3 TAB: performed in accordance with the requirements of standard under which TAB Firm's qualifications are approved:
 - .1 Associated Air Balance Council, (AABC) National Standards for Total System Balance, MN-1-2002.
 - .2 National Environmental Balancing Bureau (NEBB) TABES, Procedural Standards for Testing, Adjusting, Balancing of Environmental Systems-1998.
- .4 Recommendations and suggested practices contained in the TAB Standard: mandatory.
- .5 Use TAB Standard provisions, including checklists, and report forms to satisfy Contract requirements.
- .6 Use TAB Standard for TAB, including qualifications for TAB Firm and Specialist and calibration of TAB instruments.
- .7 Where instrument manufacturer calibration recommendations are more stringent than those listed in TAB Standard, use manufacturer's recommendations.
- .8 TAB Standard quality assurance provisions such as performance guarantees form part of this contract.
 - .1 For systems or system components not covered in TAB Standard, use TAB procedures developed by TAB Specialist.
 - .2 Where new procedures, and requirements, are applicable to Contract requirements have been published or adopted by body responsible for TAB Standard used (AABC, NEBB, or TABB), requirements and recommendations contained in these procedures and requirements are mandatory.

1.3 PURPOSE OF TAB

- .1 Test to verify proper and safe operation, determine actual point of performance, evaluate qualitative and quantitative performance of equipment, systems and controls at design, average and low loads using actual or simulated loads
- .2 Adjust and regulate equipment and systems to meet specified performance requirements and to achieve specified interaction with other related systems under normal and emergency loads and operating conditions.

- .3 Balance systems and equipment to regulate flow rates to match load requirements over full operating ranges.

1.4 EXCEPTIONS

- .1 TAB of systems and equipment regulated by codes, standards to satisfaction of authority having jurisdiction.

1.5 CO-ORDINATION

- .1 Schedule time required for TAB (including repairs, re-testing) into project construction and completion schedule to ensure completion before acceptance of project.
- .2 Do TAB of each system independently and subsequently, where interlocked with other systems, in unison with those systems.

1.6 PRE-TAB REVIEW

- .1 Review contract documents before project construction is started and confirm in writing to Departmental Representative the adequacy of provisions for TAB and other aspects of design and installation pertinent to success of TAB.
- .2 Review specified standards and report to Departmental Representative in writing proposed procedures that vary from standard.
- .3 During construction, co-ordinate location and installation of TAB devices, equipment, accessories, measurement ports and fittings.

1.7 START-UP

- .1 Follow start-up procedures as recommended by equipment manufacturer unless specified otherwise.

1.8 FOLLOW SPECIAL START-UP PROCEDURES

- .1 Notify Departmental Representative seven (7) days prior to start of TAB.
- .2 Start TAB when building is essentially completed, including:
 - .3 Installation of ceilings, doors, windows, other construction affecting TAB.
 - .4 Application of weatherstripping, sealing, and caulking.
 - .5 Pressure, leakage, or other tests specified elsewhere in Division 23.
 - .6 Provisions for TAB installed and operational.
- .7 Start-up, verification for proper, normal and safe operation of mechanical and associated electrical and control systems affecting TAB including but not limited to:
 - .1 Proper thermal overload protection in place for electrical equipment.
 - .2 Liquid systems:
 - .1 Flushed, filled, vented.
 - .2 Correct pump rotation.
 - .3 Strainers in place, baskets clean.
 - .4 Isolating and balancing valves installed, open.
 - .5 Calibrated balancing valves installed, at factory settings.
 - .6 Chemical treatment systems complete, operational.

1.9 APPLICATION TOLERANCES

- .1 Do TAB to following tolerances of design values:
 - .1 Hydronic systems: plus or minus 10 %.

1.10 ACCURACY TOLERANCES

- .1 Measured values accurate to within plus or minus 2 % of actual values.

1.11 INSTRUMENTS

- .1 Prior to TAB, submit to Departmental Representative a list of instruments used together with serial numbers.
- .2 Calibrate in accordance with requirements of most stringent of referenced standard for either applicable system or HVAC system.
- .3 Calibrate within three (3) months of TAB. Provide certificate of calibration to Departmental Representative.

1.12 SUBMITTALS

- .1 Submit, prior to commencement of TAB:
- .2 Proposed methodology and procedures for performing TAB if different from referenced standard.
- .3 .

1.13 PRELIMINARY TAB REPORT

- .1 Submit for checking and approval of Departmental Representative, prior to submission of formal TAB report, sample of rough TAB sheets. Include:
 - .1 Details of instruments used.
 - .2 Details of TAB procedures employed.
 - .3 Calculations procedures.
 - .4 Summaries.

1.14 TAB REPORT

- .1 Format in accordance with referenced standard.
- .2 TAB report to show results in SI units and to include:
 - .1 Project record drawings.
 - .2 System schematics.
- .3 Submit 6 copies of TAB Report to Departmental Representative for verification and approval, in English French both official languages in D-ring binders, complete with index tabs.

1.15 VERIFICATION

- .1 Reported results subject to verification by Departmental Representative.
- .2 Provide personnel and instrumentation to verify up to 30 % of reported results.
- .3 Number and location of verified results as directed by Departmental Representative.

- .4 Pay costs to repeat TAB as required to satisfaction of Departmental Representative.

1.16 SETTINGS

- .1 After TAB is completed to satisfaction of Departmental Representative, replace drive guards, close access doors, lock devices in set positions, ensure sensors are at required settings.
- .2 Permanently mark settings to allow restoration at any time during life of facility. Do not eradicate or cover markings.

1.17 COMPLETION OF TAB

- .1 TAB considered complete when final TAB Report received and approved by Departmental Representative.

Part 2 Products

2.1 NOT USED

- .1 Not used.

Part 3 Execution

3.1 NOT USED

- .1 Not used.

END OF SECTION

Part 1 General

1.1 REFERENCES

- .1 Air-Conditioning, Heating and Refrigeration Institute (AHRI)
 - .1 AHRI-550/590-03, Performance Rating of Water Chilling Packages Using the Vapor Compression Cycle.
- .2 CSA International
 - .1 CSA B52-05 SMART, Mechanical Refrigeration Code.
- .3 Environment Canada, (EC)/Environmental Protection Services (EPS)
 - .1 EPS 1/RA/2-1996, Environmental Code of Practice for Elimination of Fluorocarbons Emissions from Refrigeration and Air Conditioning Systems.

1.2 ACTION AND INFORMATIONAL SUBMITTALS

- .1 Submit submittals in accordance with Section 01 33 00 - Submittal Procedures.
- .2 Product Data:
 - .1 Submit manufacturer's instructions, printed product literature and data sheets for scroll water chillers and include product characteristics, performance criteria, physical size, finish and limitations.
- .3 Shop Drawings:
 - .1 Indicate:
 - .1 Equipment including connections, piping and fittings, valves, strainers, control assemblies and ancillaries, identifying factory and field assembled.
 - .2 Wiring as assembled and schematics.
 - .3 Dimensions, construction details, recommended installation and support, mounting bolt hole sizes and locations and point loads.
 - .4 Type of refrigerant used.

1.3 CLOSEOUT SUBMITTALS

- .1 Submit in accordance with Section 01 78 00 - Closeout Submittals.
- .2 Operation and Maintenance Data: submit operation and maintenance data for scroll water chiller for incorporation into manual.
- .3 Data to include:
 - .1 Description of equipment giving manufacturers name, model type and year, capacity and serial numbers.
 - .2 Provide part load performance curves.
 - .3 Details on operation, servicing and maintenance.
 - .4 Recommended spare parts list.

1.4 DELIVERY, STORAGE AND HANDLING

- .1 Deliver, store and handle materials in accordance with manufacturer's written instructions.
- .2 Delivery and Acceptance Requirements: deliver materials to site in original factory packaging, labelled with manufacturer's name and address.
- .3 Storage and Handling Requirements:
 - .1 Store materials in dry location and in accordance with manufacturer's recommendations in clean, dry, well-ventilated area.
 - .2 Store and protect chiller from nicks, scratches, and blemishes.
 - .3 Replace defective or damaged materials with new.

Part 2 Products

2.1 GENERAL

- .1 Provide complete condenserless liquid scroll type chiller package including: compressor; evaporator; motor and motor starter; controls; control centre; piping; wiring; refrigeration and oil change; ready for connection to chilled water circuit, remote refrigeration condenser, and electric power source, installed in welded steel frame with heavy gauge panels and access doors finished to manufacturers standard.

2.2 CAPACITY

- .1 Certified ratings based on AHRI 550/590:
 - .1 148.2 kW (40 tons nominal), when cooling 6.397 L/s of water from 12.22 degrees C to 6.70 degrees C.
 - .2 Power input, including electrical components: 48.52 kW.
 - .3 Fouling resistance coefficient: 0.0176 m²K/W
 - .4 Refrigerant: R410-A.

2.3 COMPRESSOR

- .1 Fully hermetic scroll type compressors operating at 3500 r/min.
- .2 Unloaded start with capacity modulation by continuous linear modulation of slide valve in response to load change.
- .3 Compressor to include suction and discharge shut-off valves; oil sight glass; separate circuit crankcase heater; and cylinder unloading device.
- .4 Provide nameplate to show capacity at design temperature, type of refrigerant used and total weight in system.
- .5 External vibration isolation – rubber in shear.

2.4 COMPRESSOR MOTOR

- .1 Fully Hermetic type with overload protection and manual restart.

2.5 EVAPORATOR

- .1 Evaporator shall be rated for a refrigerant workingside pressure of 450 psig (3103 kPa) and shall be tested for a maximum water-side pressure of 300 psig (2068 kPa).
- .2 Shall be single-pass, ANSI type 316 stainless steel, brazed plate construction.
- .3 Shall be insulated with 3/4-in. (19 mm) closed-cell, polyvinyl-chloride foam with a maximum K factor of 0.28.
- .4 Unit shall be provided with a factory-installed flow switch.
- .5 Unit shall be provided with entering and leaving chilled water temperature sensors and water pressure access port.
- .6 A strainer with a minimum of 40 mesh must be installed within 10 ft (3 m) of the heat exchanger fluid inlet to prevent debris from clogging the heat exchanger. This strainer shall be required and shall be available as an accessory.

2.6 CONTROL CENTRE

- .1 Unit controls shall include the following minimum components:
 - .1 Microprocessor.
 - .2 Power and control circuit terminal blocks.
 - .3 ON/OFF control switch.
 - .4 Thermistor is installed to measure evaporator entering and leaving fluid temperatures.
 - .5 Terminal block for temporary and/or permanent interface to the Carrier Comfort Network® or similar building system control.
- .2 Microprocessor with non-volatile memory. Battery backup system shall not be accepted.
- .3 Control transformer to serve all controllers, contactors, relays, and control components.
- .4 Replaceable solid-state relay panels and controllers.
- .5 Pressure transducers (used to calculate saturated suction temperature and saturated condensing temperature).
- .6 Provision for field installation of accessory sensor to measure compressor return gas temperature (suction gas thermistor).
- .7 Terminals shall be provided in the control box for wiring of accessory field-installed condenser temperature sensors.
- .8 Unit controls shall be capable of performing the following functions:
 - .1 Capacity control based on leaving chilled fluid temperature and compensated by rate of change of return-fluid temperature.
 - .2 Limiting of the chilled fluid temperature pulldown rate at start-up to 1° F (0.56° C) per minute to prevent excessive demand spikes (charges) at start-up.
 - .3 Seven-day time schedule.
 - .4 Leaving chilled fluid temperature reset from return fluid.
 - .5 Dual chiller control for parallel chiller applications (common leaving chilled water sensor required)

- .6 Timed maintenance scheduling to signal maintenance activities.

2.7

Diagnostics:

- .1 The control panel shall include, as standard, a scrolling marquee display capable of indicating the safety lockout condition by displaying a code for which an explanation may be scrolled at the display.
- .2 Information included for display shall be:
 - .3 Compressor lockout.
 - .4 Loss of charge.
 - .5 Low fluid flow.
 - .6 Evaporator freeze protection.
 - .7 Thermistor malfunction.
 - .8 Entering and leaving-fluid temperature.
 - .9 Circuit suction and discharge pressure.
 - .10 Time of day.
- .11 Display module, in conjunction with the microprocessor, must also be capable of displaying the output (results) of a service test. Service test shall verify operation of every switch, thermistor, and compressors before chiller is started.
- .12 Diagnostics shall include the ability to review a list of the 20 most recent alarms with clear language descriptions of the alarm event. Display of alarm codes without the ability for clear language descriptions shall be prohibited.
- .13 An alarm history buffer shall allow the user to store no less than 20 alarm events with clear language descriptions, time and date stamp event entry.
- .14 The chiller controller shall include a connection port for communicating with the local equipment network and the Carrier Comfort Network (CCN) system.
- .15 The control system shall allow software upgrade without the need for new hardware modules.

2.8

Safeties:

- .1 Unit shall be equipped with sensors and all necessary components in conjunction with the control system to provide the unit with the following protections:
 - .1 Loss of refrigerant charge protection.
 - .2 Low fluid flow detection.
 - .3 Low chilled fluid temperature protection.
 - .4 Low control voltage (unit) protection.
 - .5 High-pressure switch.
 - .6 Reverse rotation.
 - .7 Overcurrent protection.
 - .8 Loss of phase.
- .2 Compressors shall be equipped with the following protections:
 - .1 High discharge temperature protection.

- .2 Electrical overload through the use of definite-purpose contactors and motor overload protection through internal compressor overload or external current overload.
- .3 Circuit breakers shall open all 3 phases in the event of an overload in any one phase (single-phasing condition).
- .4 Circuit breakers for short circuit protection.

2.9 Operating Characteristics:

- .1 Unit shall be capable of starting with up to 95 F (35 C) fluid temperature entering the evaporator.
- .2 Unit shall be capable of operating with variable evaporator fluid flow, up to 10% change in flow rate per minute.

2.10 Electrical Requirements:

- .1 Single-point electrical power connection with compressors factory-wired to a terminal block in the control panel. Compressor sensors and system pressure transducers shall be factory wired to the unit controller.
- .2 Control interface shall be accessed through low voltage terminal strip or terminal strip.

2.11 Chilled Water Circuit:

- .1 Chilled water circuit shall be rated for 300 psig (2068 kPa).
- .2 Solid-state flow switch with integral relay shall be factory installed and wired.

2.12 Special Features:

- .1 Hot Gas Bypass:
 - .1 This factory-installed option shall permit chiller to provide an additional step of capacity reduction over standard.
- .2 Non-Fused Disconnect:
 - .1 The non-fused disconnect shall be factory installed and shall disconnect all power to the unit (including control circuit power).
- .3 Vibration isolation pads
- .4 Strainer on chilled water (40 mesh)

2.13 Remote condenser

- .1 General:
 - .1 Factory assembled, single-piece, air-cooled remote condenser. Contained within the unit enclosure shall be all factory wiring, piping, controls, nitrogen holding charge, and special features required prior to field start-up.
- .2 Unit Cabinet:
 - .1 Cabinet shall be galvanized steel casing with a baked enamel powder or pre-painted finish.

-
- .2 Cabinet shall be capable of withstanding 500-hr salt spray test in accordance with ASTM (U.S.A.) B-117 standard.
 - .3 Control box access panels shall be removable for service access.
 - .4 Lifting holes shall be provided to facilitate rigging.
 - .3 Fans:
 - .1 Condenser fans shall be direct-drive propeller type, discharging air vertically upward.
 - .2 All condenser fan motors shall be totally enclosed 3-phase type with permanently lubricated ball bearings, class F insulation and internal, automatic-reset thermal overload protection.
 - .3 Shafts shall have inherent corrosion resistance.
 - .4 Fan blades shall be statically and dynamically balanced.
 - .5 Condenser-fan openings shall be equipped with PVC-coated steel wire safety guards.
 - .4 Condenser Coils:
 - .1 Coil shall be air-cooled microchannel heat exchanger (MCHX) and shall have a series of flat tubes containing a series of multiple, parallel flow microchannels layered between the refrigerant manifolds. Microchannel coils shall consist of a two-pass arrangement. Coil construction shall consist of aluminum alloys for the fins, tubes and manifolds in combination with a corrosion-resistant coating on the tubes.
 - .2 Tubes shall be cleaned, dehydrated, and sealed.
 - .3 Assembled condenser coils shall be leak tested and pressure tested at 650 psig (4482 kPa).
 - .5 Refrigeration Components:
 - .1 Refrigeration circuit components shall include liquid line temperature relief device and nitrogen holding charge.
 - .6 Controls and Safeties:
 - .1 Unit controls shall include:
 - .1 Unit shall have a temperature fusible plug for safety on each refrigerant circuit.
 - .2 Self-contained low voltage control circuit.
 - .3 Cycle condenser fans to maintain proper head pressure control.
 - .7 Operating Characteristics:
 - .1 Unit shall be capable of rejecting the required heat at the required cfm and be capable of operating down to moderate ambient temperatures with standard factory supplied fan cycling.
 - .8 Electrical Requirements:
 - .1 A dual power supply of the correct voltage shall be required for each series unit. A 3-phase power circuit voltage and a 24 volt single-phase control circuit shall be required.

- .2 The number of control circuits shall depend on the unit application, whether it is matched with one unit or two units.
- .3 Power supplies for all units shall enter the control box through factory-punched entrance holes in the control box shelf.
- .4 Units shall utilize electromechanical fan cycling head pressure controls to control proper head pressure.
- .9 Special Features:
 - .1 Non-Fused Disconnect:
 - .1 A non-fused disconnect is available as a factory- installed option for all units having single point power connection units.
- .10 Vibration Isolation Pads:
 - .1 Neoprene vibration isolation pads (24 in. x 3 in. x 1/4 in.) shall be available for field installation to reduce vibration transmission from the compressor through the floor and into the conditioned space.

Part 3 Execution

3.1 EXAMINATION

- .1 Verification of Conditions: verify conditions of substrates previously installed under other Sections or Contracts are acceptable for rotary-screw water chiller installation in accordance with manufacturer's written instructions.
 - .1 Visually inspect substrate in presence of Departmental Representative.
 - .2 Inform Departmental Representative.
 - .3 Proceed with installation only after unacceptable conditions have been remedied and after receipt of written approval to proceed from Departmental Representative

3.2 APPLICATION

- .1 Manufacturer's Instructions: comply with manufacturer's written recommendations, including product technical bulletins, product catalogue installation instructions, product carton installation instructions, and data sheets.

3.3 GENERAL

- .1 Provide appropriate protection apparatus.
- .2 Install unit as indicated, to manufacturers recommendations, and in accordance with EPS 1/RA/2.
- .3 Ensure adequate clearances for servicing and maintenance.
- .4 Manufacturer to approve installation, to supervise startup and to instruct operators. Include 3 days per unit.

3.4 STRUCTURAL SUPPORT

- .1 Reuse existing roof curbs approx. 9' a part (field measurement is required). Provide structural base rail spanning over existing roof curbs supporting new chiller.

3.5 CLEANING

- .1 Progress Cleaning: clean in accordance with Section 01 74 11 - Cleaning.
 - .1 Leave Work area clean at end of each day.
 - .2 Final Cleaning: upon completion remove surplus materials, rubbish, tools and equipment in accordance with Section [01 74 11 - Cleaning].

3.6 PROTECTION

- .1 Protect installed products and components from damage during construction.
- .2 Repair damage to adjacent materials caused by scroll water chiller installation.

END OF SECTION

Part 1 General

1.1 SUMMARY

- .1 Section Includes:
 - .1 General requirements that are common to NMS sections found in Division 26 – Electrical. This section supplements requirements of Division 1.

1.2 REFERENCES

- .1 Canadian Standards Association (CSA International)
 - .1 CSA C22.1-12, Canadian Electrical Code
 - .2 CSA C22.2
 - .3 CAN/CSA-C22.3 No. 1-01, Overhead Systems.
 - .4 CAN3-C235-83(R2000), Preferred Voltage Levels for AC Systems, 0 to 50,000V.
- .2 Electrical and Electronic Manufacturer's Association of Canada (EEMAC)
 - .1 EEMAC 2Y-1-1958, Light Gray Colour for Indoor Switch Gear.
- .3 Health Canada / Workplace Hazardous Materials Information System (WHMIS)
 - .1 Material Safety Data Sheets (MSDS).

1.3 DESIGN REQUIREMENTS

- .1 Operating voltages: to CAN3-C235.
- .2 Motors, electric heating, control and distribution devices and equipment to operate satisfactorily at 60 Hz within normal operating limits established by above standard.
 - .1 Equipment to operate in extreme operating conditions established in above standard without damage to equipment.
- .3 Language operating requirements: provide identification nameplates and labels for control items in English and French.
- .4 Use one nameplate or label for each language.

1.4 SUBMITTALS

- .1 Shop drawings:
 - .1 Submit drawings for review, prior to ordering/purchasing any equipment.
- .2 Quality Control:
 - .1 Provide CSA certified equipment and material.
 - .2 Where CSA certified equipment and material is not available, submit such equipment and material to authority having jurisdiction for special approval before delivery to site.
 - .3 Submit test results of installed electrical systems and instrumentation.
 - .4 Permits and fees: in accordance with General Conditions of contract.

- .5 Submit, upon completion of Work, load balance report as described in PART 3 - Load Balance.
- .6 Submit certificate of acceptance from authority having jurisdiction upon completion of Work to Departmental Representative.
- .3 Manufacturer's Field Reports: submit to Departmental Representative, manufacturer's written report, within 3 days of review, verifying compliance of Work and electrical system and instrumentation testing, as described in PART 3 - FIELD QUALITY CONTROL.

1.5 QUALITY ASSURANCE

- .1 Qualifications: electrical Work to be carried out by qualified, licensed electricians who hold valid Master Electrical Contractor license or apprentices in accordance with authorities having jurisdiction.

1.6 SYSTEM STARTUP

- .1 Instruct, Departmental Representative and operating personnel in operation, care and maintenance of systems, system equipment and components.
- .2 Arrange and pay for services of manufacturer's factory service engineer to supervise start-up of installation, check, adjust, balance and calibrate components and instruct operating personnel.
- .3 Provide these services for such period, and for as many visits as necessary to put equipment in operation, and ensure that operating personnel are conversant will aspects of its care and operation.

Part 2 Products

2.1 MATERIALS AND EQUIPMENT

- .1 Material and equipment to be CSA certified. Where CSA certified equipment is not available, obtain special approval from authority having jurisdiction.
- .2 Factory-assemble control panels and component assemblies.

2.2 ELECTRIC MOTORS, EQUIPMENT AND CONTROLS

- .1 Verify installation and co-ordination responsibilities related to motors, equipment and controls, as indicated.
- .2 Control wiring and conduit is specified in Division 26 except for conduit, wiring and connections below 50 V which are related to control systems specified in Divisions 21, 22 and 23 and as shown on mechanical drawings.

2.3 WARNING SIGNS

- .1 As specified and to meet requirements of Electrical Inspection Department.
- .2 Decal signs, minimum size 175 x 250 mm.

2.4 WIRING TERMINATIONS

- .1 Ensure lugs, terminals, screws used for termination of wiring are suitable for either copper or aluminum conductors.

2.5 EQUIPMENT IDENTIFICATION

- .1 Identify electrical equipment with nameplates and labels as follows:
 - .1 Nameplates: lamicoïd 3 mm thick plastic engraving sheet, black face, white core, mechanically attached with self-tapping screws.
 - .2 Sizes as follows:

NAMEPLATE SIZES			
Size 1	10 x 50 mm	1 line	3 mm high letters
Size 2	12 x 70 mm	1 line	5 mm high letters
Size 3	12 x 70 mm	2 lines	3 mm high letters
Size 4	20 x 90 mm	1 line	8 mm high letters
Size 5	20 x 90 mm	2 lines	5 mm high letters
Size 6	25 x 100 mm	1 line	12 mm high letters
Size 7	25 x 100 mm	2 lines	6 mm high letters

- .2 Labels: embossed plastic labels with 6 mm high letters unless specified otherwise.
- .3 Wording on nameplates and labels to be approved by Departmental Representative prior to manufacture.
- .4 Allow for minimum of twenty-five (25) letters per nameplate and label.
- .5 Nameplates for terminal cabinets and junction boxes to indicate system and/or voltage characteristics.
- .6 Disconnects, starters and contactors: indicate equipment being controlled and voltage.
- .7 Terminal cabinets and pull boxes: indicate system and voltage.
- .8 Transformers: indicate capacity, primary and secondary voltages.

2.6 WIRING IDENTIFICATION

- .1 Identify wiring with permanent indelible identifying markings, numbered or coloured plastic tapes, on both ends of phase conductors of feeders and branch circuit wiring.
- .2 Maintain phase sequence and colour coding throughout.
- .3 Colour coding: to CSA C22.10-07.
- .4 Use colour-coded wires in communication cables, matched throughout system.

2.7 CONDUIT AND CABLE IDENTIFICATION

- .1 Colour code conduits, boxes and metallic sheathed cables.
- .2 Code with plastic tape or paint at points where conduit or cable enters wall, ceiling, or floor, and at 15 m intervals.
- .3 Colours: 25 mm wide prime colour and 20 mm wide auxiliary colour.

	Prime	Auxiliary
up to 250 V	Yellow	
up to 600 V	Yellow	Green

	Prime	Auxiliary
up to 5 kV	Yellow	Blue
up to 15 kV	Yellow	Red
Telephone	Green	
Other Communication Systems	Green	Blue
Fire Alarm	Red	
Emergency Voice	Red	Blue
Other Security Systems	Red	Yellow

2.8 FINISHES

- .1 Shop finish metal enclosure surfaces by application of rust resistant primer inside and outside, and at least two coats of finish enamel.

Part 3 Execution

3.1 INSTALLATION

- .1 Do complete installation in accordance with CSA C22.1 except where specified otherwise.
- .2 Do overhead and underground systems in accordance with CSA C22.3 No.1 except where specified otherwise.

3.2 NAMEPLATES AND LABELS

- .1 Ensure manufacturer's nameplates, CSA labels and identification nameplates are visible and legible after equipment is installed.

3.3 CONDUIT AND CABLE INSTALLATION

- .1 Install conduit and sleeves prior to pouring of concrete.
 - .1 Sleeves through concrete: schedule 40 steel pipe, sized for free passage of conduit, and protruding 50 mm.
- .2 If plastic sleeves are used in fire rated walls or floors, remove before conduit installation.
- .3 Install cables, conduits and fittings to be embedded or plastered over, neatly and close to building structure so furring can be kept to minimum.

3.4 LOCATION OF OUTLETS

- .1 Locate outlets as shown on drawings.
- .2 Do not install outlets back-to-back in wall; allow minimum 150 mm horizontal clearance between boxes.
- .3 Change location of outlets at no extra cost or credit, providing distance does not exceed 3000 mm, and information is given before installation.
- .4 Locate light switches on latch side of doors.
 - .1 Locate disconnect devices in mechanical and elevator machine rooms on latch side of floor.

3.5 MOUNTING HEIGHTS

- .1 Mounting height of equipment is from finished floor to centreline of equipment unless specified or indicated otherwise.
- .2 If mounting height of equipment is not specified or indicated, verify before proceeding with installation.

3.6 CO-ORDINATION OF PROTECTIVE DEVICES

- .1 Ensure circuit protective devices such as overcurrent trips, relays and fuses are installed to required values and settings.

3.7 FIELD QUALITY CONTROL

- .1 Load Balance:
 - .1 Measure phase current to panelboards with normal loads (lighting) operating at time of acceptance; adjust branch circuit connections as required to obtain best balance of current between phases and record changes.
 - .2 Measure phase voltages at loads and adjust transformer taps to within 2% of rated voltage of equipment.
 - .3 Provide upon completion of work, load balance report as directed in PART 1 - Submittals: phase and neutral currents on panelboards, dry-core transformers and motor control centres, operating under normal load, as well as hour and date on which each load was measured, and voltage at time of test.
- .2 Conduct and pay for the following tests:
 - .1 Power generation and distribution system including phasing, voltage, grounding and load balancing.
 - .2 Circuits originating from branch distribution panels.
 - .3 Lighting and its control.
 - .4 Motors, heaters and associated control equipment including sequenced operation of systems where applicable.
 - .5 Systems: fire alarm system, communications.
 - .6 Insulation resistance testing:
 - .1 Electrical insulation and leakage test circuits, feeders and equipment up to 350 V with a 500 V instrument.
 - .2 Electrical insulation and leakage test 350-600 V circuits, feeders and equipment with a 1000 V instrument.
 - .3 Check resistance to ground before energizing.
- .3 Carry out tests in presence of Departmental Representative.
- .4 Provide instruments, meters, equipment and personnel required to conduct tests during and at conclusion of project.
- .5 Manufacturer's Field Services:
 - .1 Obtain written report from manufacturer verifying compliance of Work, in handling, installing, applying, protecting and cleaning of product and submit Manufacturer's Field Report(s).

- .2 Provide manufacturer's field services consisting of product use recommendations and periodic site visits for inspection of product installation in accordance with manufacturer's instructions.

3.8 CLEANING

- .1 Clean and touch up surfaces of shop-painted equipment scratched or marred during shipment or installation, to match original paint.
- .2 Clean and prime exposed non-galvanized hangers, racks and fastenings to prevent rusting.

3.9 COORDINATION OF MECHANICAL AND ELECTRICAL WORK

- .1 Provide complete wiring and connections for all motors and other electrical equipment specified in Division 22 and 23.
- .2 Determine characteristics of equipment specified in Division 22 and 23. Provide proper starters, relays, coils, auxiliary contacts and interlocks.

END OF SECTION

Part 1 General

1.1 REFERENCES

- .1 Canadian Standards Association (CSA International)
 - .1 CAN/CSA-C22.2No.18-13, Outlet Boxes, Conduit Boxes, Fittings and Associated Hardware.
 - .2 CSA C22.2No.65-13, Wire Connectors.
- .2 Electrical and Electronic Manufacturers' Association of Canada (EEMAC)
 - .1 EEMAC 1Y-2, 1961 Bushing Stud Connectors and Aluminum Adapters (1200 Ampere Maximum Rating).
- .3 National Electrical Manufacturers Association (NEMA)

Part 2 Products

2.1 MATERIALS

- .1 Pressure type wire connectors with current carrying parts of copper sized to fit copper conductors as required.
- .2 Fixture type splicing connectors with current carrying parts of copper sized to fit copper conductors 10 AWG or less.
- .3 Clamps or connectors for armoured cable, flexible conduit as required.

Part 3 Execution

3.1 INSTALLATION

- .1 Remove insulation carefully from ends of conductors and:
 - .1 Install mechanical pressure type connectors and tighten screws with appropriate compression tool recommended by manufacturer. Installation shall meet secureness tests in accordance with CSA C22.2 No.65.
 - .2 Install fixture type connectors and tighten. Replace insulating cap.

END OF SECTION

Part 1 General

1.1 GENERAL

- .1 In general, the wiring is not shown on the drawings for the different systems: the necessary wiring shall however be provided between all outlets and the panels and/or relays to which they are referred to on drawings. In some cases, the panel identification is not given for each circuit but is shown for particular area.

Part 2 Products

2.1 BUILDING WIRES

- .1 Conductors: stranded for 10 AWG and larger. Minimum size: 12 AWG.
- .2 Copper conductors: size as indicated, with 1000 V insulation of chemically cross-linked thermosetting polyethylene material rated RW90.

2.2 UNDERGROUND WIRES (DUCT BANK)

- .1 Conductors: stranded
- .2 Copper conductors: size as indicated, with 1000 V insulation of chemically cross-linked thermosetting polyethylene material rated RW90.

2.3 TECK CABLE

- .1 Cable: to CAN/CSA-C22.2 No. 131-14.
- .2 Conductors:
 - .1 Grounding conductor: copper.
 - .2 Circuit conductors: copper, size as indicated.
- .3 Connectors:
 - .1 Watertight, approved for TECK cable.

Part 3 Execution

3.1 INSTALLATION OF BUILDING WIRES

- .1 Install wiring as follows:
 - .1 All cables in suspended ceiling shall be properly strapped.
 - .2 Use armoured cables only in suspended ceilings when making final connection to equipment or in location(s) pre-approved by Departmental Representative.

3.2 INSTALLATION OF TECK CABLE 0 TO 1000 V

- .1 Install cables.
 - .1 Group cables wherever possible on channels.
- .2 Terminate cables in accordance with Section 26 05 20 - Wire and Box Connectors - 0 TO 1000 V.

END OF SECTION

Part 1 General

1.1 REFERENCES

- .1 American National Standards Institute (ANSI)/Institute of Electrical and Electronics Engineers (IEEE)
 - .1 ANSI/IEEE 837-1996, Qualifying Permanent Connections Used in Substation Grounding.
- .2 Canadian Standards Association, (CSA International)

Part 2 Products

2.1 EQUIPMENT

- .1 Clamps for grounding of conductor: size as required to electrically conductive underground water pipe.
- .2 System and circuit, equipment, grounding conductors, bare, stranded copper, soft annealed, size as required.
- .3 Insulated grounding conductors: To be to Section 26 05 21 – Wiring and Cables (0-1000V).
- .4 Non-corroding accessories necessary for grounding system, type, size, material as indicated, including but not necessarily limited to:
 - .1 Grounding and bonding bushings.
 - .2 Protective type clamps.
 - .3 Bolted type conductor connectors.
 - .4 Thermite-welded type conductor connectors.
 - .5 Bonding jumpers, straps.
 - .6 Pressure wire connectors.

Part 3 Execution

3.1 INSTALLATION GENERAL

- .1 Install complete permanent, continuous grounding system including, electrodes, conductors, connectors, accessories. Where EMT is used, run ground wire in conduit.
- .2 Install connectors in accordance with manufacturer's instructions.
- .3 Protect exposed grounding conductors from mechanical injury.
- .4 Use mechanical connectors for grounding connections to equipment provided with lugs.
- .5 Soldered joints not permitted.
- .6 Install bonding wire for flexible conduit, connected at both end to grounding bushing, solderless lug, clamp or cup washer and screw. Neatly cleat bonding wire to exterior of flexible conduit.

- .7 Make grounding connections in radial configuration only, with connections terminating at single grounding point. Avoid loop connections.

3.2 EQUIPMENT GROUNDING

- .1 Install grounding connections to typical equipment included in, but not necessarily limited to following list. Service equipment, transformers, switchgear, duct systems, frames of motors, motor control centres, starters, control panels, building steel work, generators, elevators and escalators, distribution panels, outdoor lighting.

3.3 FIELD QUALITY CONTROL

- .1 Perform tests in accordance with Section 26 05 00 – Electrical General Requirements.
- .2 Perform ground continuity and resistance tests using method appropriate to site conditions and to approval of Departmental Representative and local authority having jurisdiction over installation.
- .3 Perform tests before energizing electrical system.
- .4 Disconnect ground fault indicator during tests.

END OF SECTION

Part 1 General

1.1 SPLITTERS

- .1 Sheet metal enclosure, welded corners and formed hinged cover suitable for locking in closed position.
- .2 Main and branch lugs to match required size and number of incoming and outgoing conductors as indicated.
- .3 At least three spare terminals on each set of lugs in splitters less than 400 A.

1.2 JUNCTION AND PULL BOXES

- .1 Welded steel construction with screw-on flat covers for surface mounting.
- .2 Covers with 25 mm minimum extension all around, for flush-mounted pull and junction boxes.

Part 2 Execution

2.1 SPLITTER INSTALLATION

- .1 Install splitters and mount plumb, true and square to the building lines.
- .2 Extend splitters full length of equipment arrangement except where indicated otherwise.

2.2 JUNCTION, PULL BOXES AND CABINETS INSTALLATION

- .1 Install pull boxes in inconspicuous but accessible locations.
- .2 Mount cabinets with top not higher than 2 m above finished floor.
- .3 Only main junction and pull boxes are indicated. Install pull boxes so as not to exceed 30 m of conduit run between pull boxes.

2.3 IDENTIFICATION

- .1 Provide equipment identification in accordance with Section 26 05 00 – Electrical General Requirements.
- .2 Install size 2 identification labels indicating voltage and phase.

END OF SECTION

Part 1 General

1.1 LOCATION OF CONDUITS

- .1 Drawings do not indicate all conduit runs. Those indicated are in diagrammatic form only.

Part 2 Products

2.1 CONDUITS

- .1 Rigid metal conduit: to CSA C22.2 No. 45, galvanized steel, threaded.
- .2 Electrical metallic tubing (EMT): to CSA C22.2 No. 83, with couplings.
- .3 Rigid pvc conduit: to CSA C22.2 No. 211.2.
- .4 Flexible metal conduit: to CSA C22.2 No. 56, liquid-tight flexible metal.

2.2 CONDUIT FASTENINGS

- .1 One hole steel straps to secure surface conduits 50 mm and smaller. Two hole steel straps for conduits larger than 50 mm.
- .2 Beam clamps to secure conduits to exposed steel work.
- .3 Channel type supports for two or more conduits at 5 m oc.
- .4 Threaded rods, 6 mm dia., to support suspended channels.

2.3 CONDUIT FITTINGS

- .1 Fittings: manufactured for use with conduit specified. Coating: same as conduit.
- .2 Factory "ells" where 90 degree bends are required for 25 mm and larger conduits.
- .3 Watertight connectors and couplings for EMT. Set-screws are not acceptable.

2.4 EXPANSION FITTINGS FOR RIGID CONDUIT

- .1 Weatherproof expansion fittings with internal bonding assembly suitable for 200 mm linear expansion.
- .2 Watertight expansion fittings with integral bonding jumper suitable for linear expansion and 19 mm deflection in all directions.
- .3 Weatherproof expansion fittings for linear expansion at entry to panel.

2.5 FISH CORD

- .1 Polypropylene.

Part 3 Execution

3.1 INSTALLATION

- .1 Install conduits to conserve headroom in exposed locations and cause minimum interference in spaces through which they pass.
- .2 Conceal conduits except in mechanical and electrical service rooms and in unfinished areas.
- .3 Use rigid galvanized steel threaded conduit except where conduit is subject to mechanical injury.
- .4 Use electrical metallic tubing (EMT) for general use, except in cast concrete.
- .5 Use rigid PVC conduit underground.
- .6 Use flexible metal conduit for connection to motors in dry areas, connection to recessed incandescent fixtures without a prewired outlet box, connection to surface or recessed fluorescent fixtures and work in movable metal partitions.
- .7 Use liquid tight flexible metal conduit for connection to motors or vibrating equipment in damp, wet or corrosive locations.
- .8 Install conduit sealing fittings in hazardous areas. Fill with compound.
- .9 Minimum conduit size for lighting and power circuits: 19 mm.
- .10 Bend conduit cold. Replace conduit if kinked or flattened more than 1/10th of its original diameter.
- .11 Mechanically bend steel conduit over 19 mm dia.
- .12 Field threads on rigid conduit must be of sufficient length to draw conduits up tight.
- .13 Install fish cord in empty conduits.
- .14 Remove and replace blocked conduit sections. Do not use liquids to clean out conduits.
- .15 Dry conduits out before installing wire.

3.2 SURFACE CONDUITS

- .1 Run parallel or perpendicular to building lines.
- .2 Locate conduits behind infrared or gas fired heaters with 1.5 m clearance.
- .3 Run conduits in flanged portion of structural steel.
- .4 Group conduits wherever possible on suspended or surface channels.
- .5 Do not pass conduits through structural members except as indicated.
- .6 Do not locate conduits less than 75 mm parallel to steam or hot water lines with minimum of 25 mm at crossovers.

END OF SECTION

Part 1 General**1.1 REFERENCES**

- .1 Canadian Standards Association (CSA International).
 - .1 CSA-C22.2 No. 5-13, Moulded-Case Circuit Breakers, Molded-Case Switches.

1.2 SUBMITTALS

- .1 Submit product data in accordance with General Instructions.

1.3 BREAKERS GENERAL

- .1 Bolt-on moulded case circuit breaker: quick- make, quick-break type, for manual and automatic operation with temperature compensation for 40 degrees C ambient.
- .2 Common-trip breakers: with single handle for multi-pole applications.
- .3 Magnetic instantaneous trip elements in circuit breakers to operate only when value of current reaches setting.
 - .1 Trip settings on breakers with adjustable trips to range from 3-8 times current rating.
- .4 Circuit breakers with interchangeable trips as indicated.
- .5 Breaker interrupting capacity
 - .1 600V panelboards: 25kA symmetrical.
 - .2 250V panelboards: 10kA symmetrical.

1.4 THERMAL MAGNETIC BREAKERS

- .1 Moulded case circuit breaker to operate automatically by means of thermal and magnetic tripping devices to provide inverse time current tripping and instantaneous tripping for short circuit protection.

Part 2 Execution**2.1 INSTALLATION**

- .1 Install circuit breakers as indicated.

END OF SECTION

Part 1 General

1.1 SUBMITTALS

- .1 Submit product data in accordance with Section 01 33 00 – Submittal Procedures.

Part 2 Products

2.1 DISCONNECT SWITCHES

- .1 Fusible/non-fusible, disconnect switch in CSA Enclosure, size as indicated.
- .2 Provision for padlocking in on-off switch position by locks.
- .3 Mechanically interlocked door to prevent opening when handle in ON position.
- .4 Fuses: size as indicated.
- .5 Fuseholders: Relocatable and suitable without adaptors, for type and size of fuse indicated.
- .6 Quick-make, quick-break action.
- .7 ON-OFF switch position indication on switch enclosure cover.
- .8 Complete with Drip Shields

2.2 EQUIPMENT IDENTIFICATION

- .1 Provide equipment identification in accordance with Section 26 05 00 – Electrical General Requirements.
- .2 Indicate name of load controlled on Size 4 nameplate.

Part 3 Execution

3.1 INSTALLATION

- .1 Install disconnect switches complete with fuses if applicable.

END OF SECTION

Part 1 — General

1.01 DEVICE DESCRIPTION

- A. The system control panel shall consist of a centrally located, pre-programmed microprocessor-based control panel with the capability to coordinate, manage, and operate two circulating pump system.
- B. The system control panel shall be CE Mark, CSA and UL 873 recognized.
- C. Panel to control 600v/3ph circulating pumps.

Part 2 — Products

2.01 GENERAL DESCRIPTION

- A. The system control panel shall be factory tested and assembled and have the capability to operate and manage both circulation pumps.
- B. The system control panel shall provide loop control functions for systems with a chiller and two circulating pumps.
- C. The system control panel shall accommodate and work in a direct digital control (DDC) type of system operation with chiller controls.
- D. The central main logic processing control module shall consist of a controller, preprogrammed and packaged in a NEMA rated enclosure. The panel enclosure shall have a lockable access door to prevent unauthorized access.
- E. The system control panel display shall be factory mounted on the front side of the enclosure. The display shall provide access to all operating and configuration parameters in the loop controller panel not limited to but including: pump lead lag control sequence, start/stop/status.
- F. The system control panel shall have the capability to include one additional input/output module for extended timeclock control of lead lag function.

2.02 OPERATION

- A. Functional:
 1. The system control panel shall coordinate the start and stop of the chilled water loop circulating pumps.
 2. The system control panel shall coordinate the shut down of the system in case of fire, loss of water flow.
- B. System:
 1. The system control panel shall control circulating water pumps to maintain water flow to the chiller based on signal from chiller control panel.

Part 3 — Execution

3.01 SEQUENCE OF OPERATION

1. General:

Circulation pumps shall be directly controlled and monitored by lead/lag control panel receiving start stop signal from chiller control panel.
2. Sequence:

Controller logic system shall monitor each pump's differential pressure switch. During day mode, the lead pump shall run continuously. The lag pump shall automatically start on failure of lead pump as determined by differential pressure switch. Controller logic shall permit pumps to change lead/lag upon command from operator's terminal or if lead pump fails during operation.
3. Provide pressure differential switches on each pump. Controller logic shall generate an out-of-normal condition at the controller, resulting in an alarm (after an adjustable time delay) at the operator's terminal when commanded pump fails to start.
4. System user at operator's terminal shall be able to jog pump lead/lag, or be able to schedule automatic jog.
5. Commands / Displays:

Provide for each pump, the following commands/displays at operator's terminal:

- A. Current pump status (differential pressure switch)
 - B. Standby pump selection (manually and automatically)
 - C. Runtime hours accumulation.
 - D. Water flow, pump failure, and maintenance alarms.
 - E. Maintenance message generation.
 - F. Alarm history.
 - G. Operation trendlogs.
 - H. Manual/auto (scheduled) command.
 - I. Manual/auto pump lead/lag jog command.
 - J. Manual pump alarm reset.
6. Standard factory logic control sequences shall be supplied for loading into controller. Logic sequences shall be field modifiable to provide any necessary site customizations. Factory control programs shall be proportional plus integral type, maintaining maximum accuracy and stability. Controller shall be programmable, either locally or over the EMS network

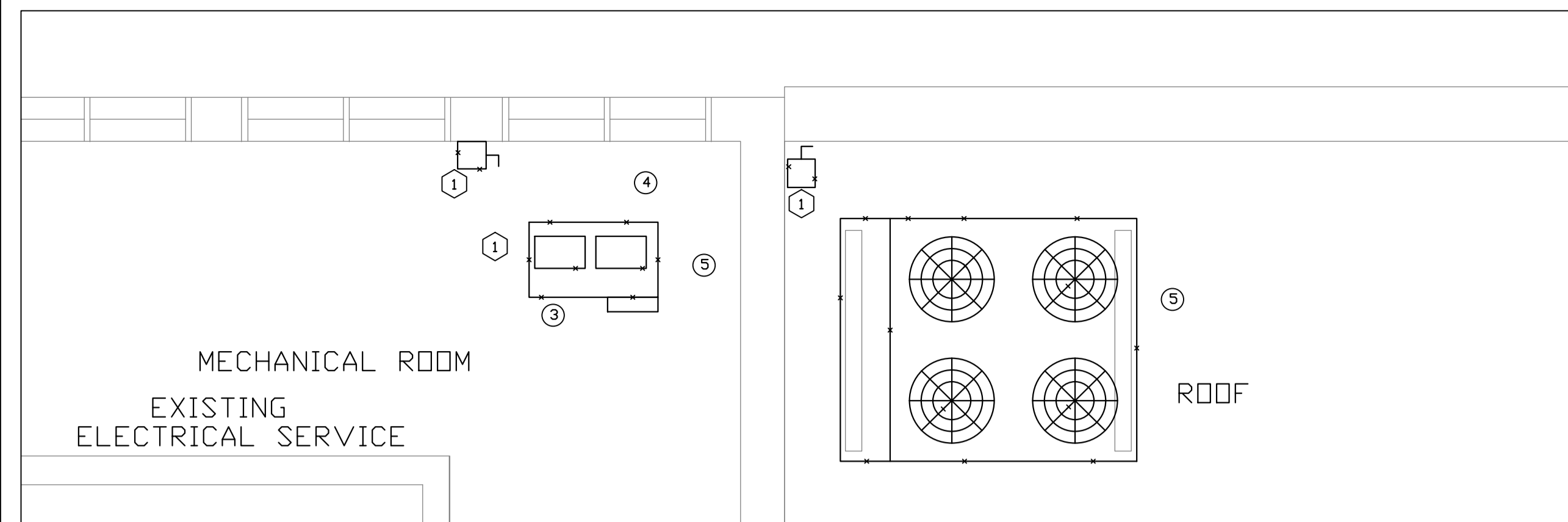

EXISTING AND DEMOLITION

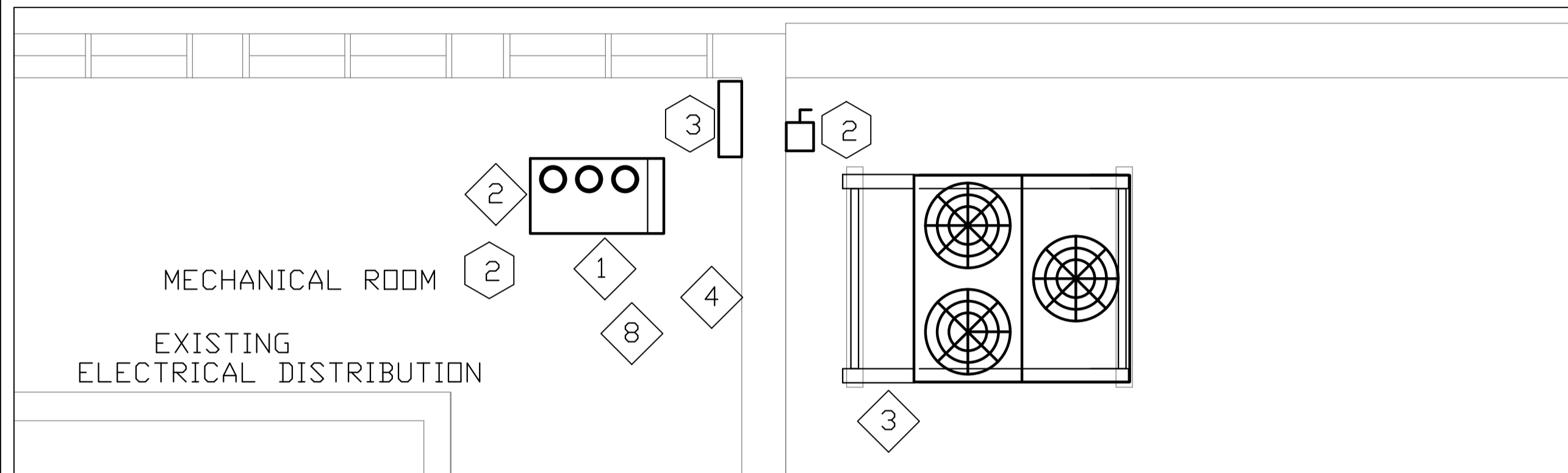

NEW INSTALLATION

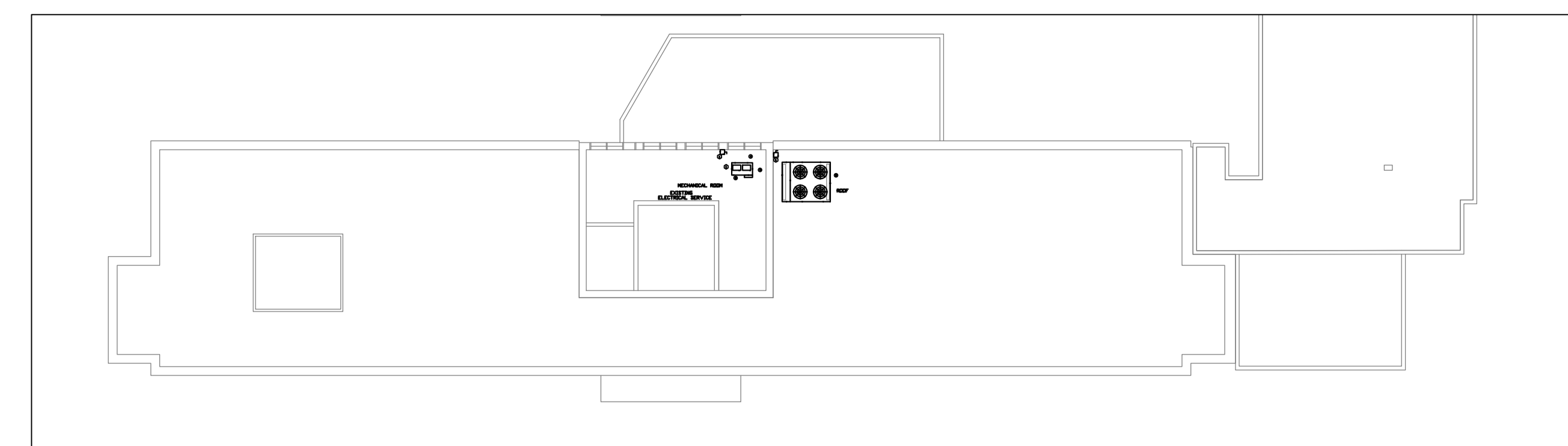

ROOF PLAN

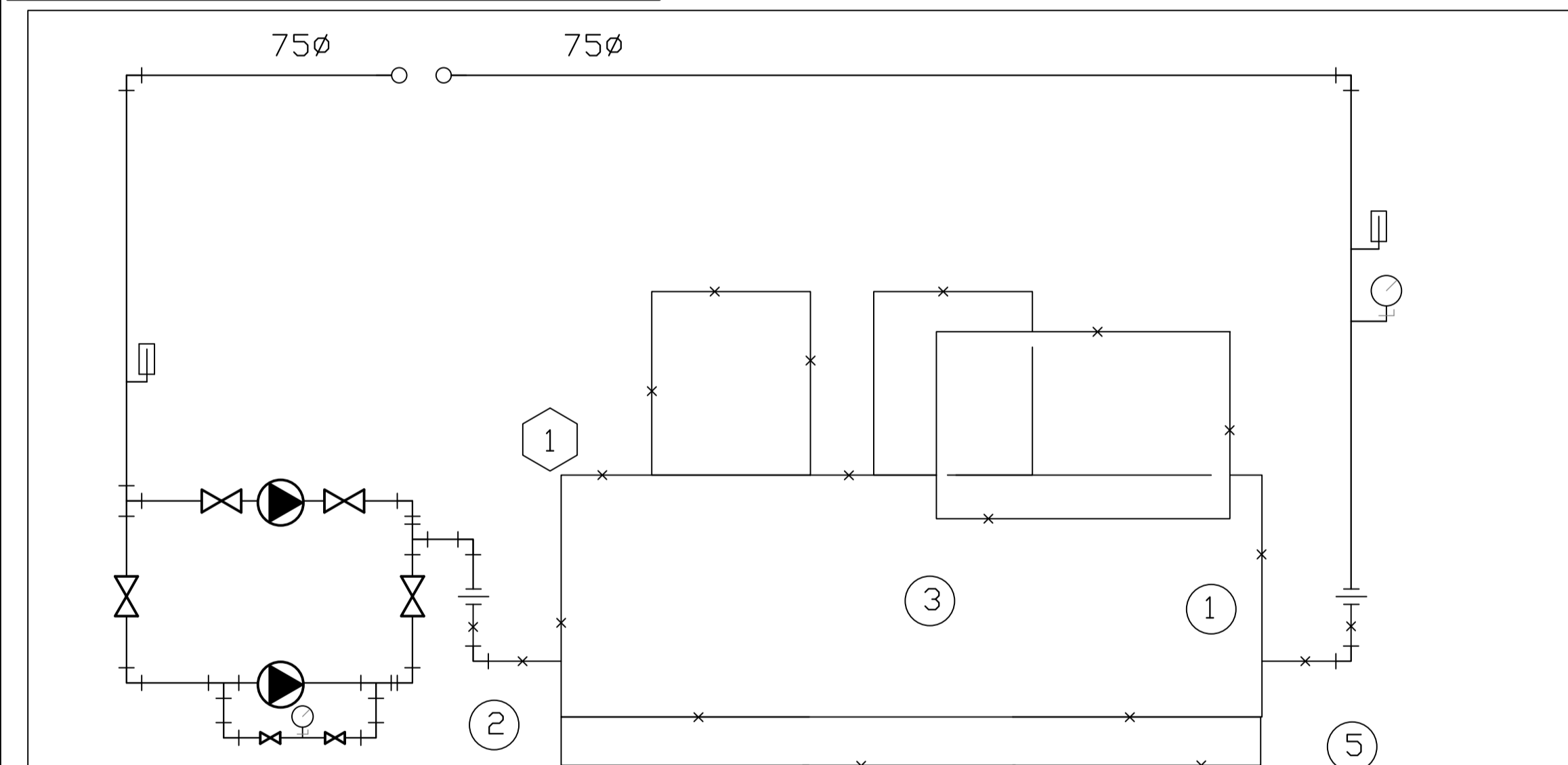

EXISTING AND DEMOLITION - SCHEMATIC

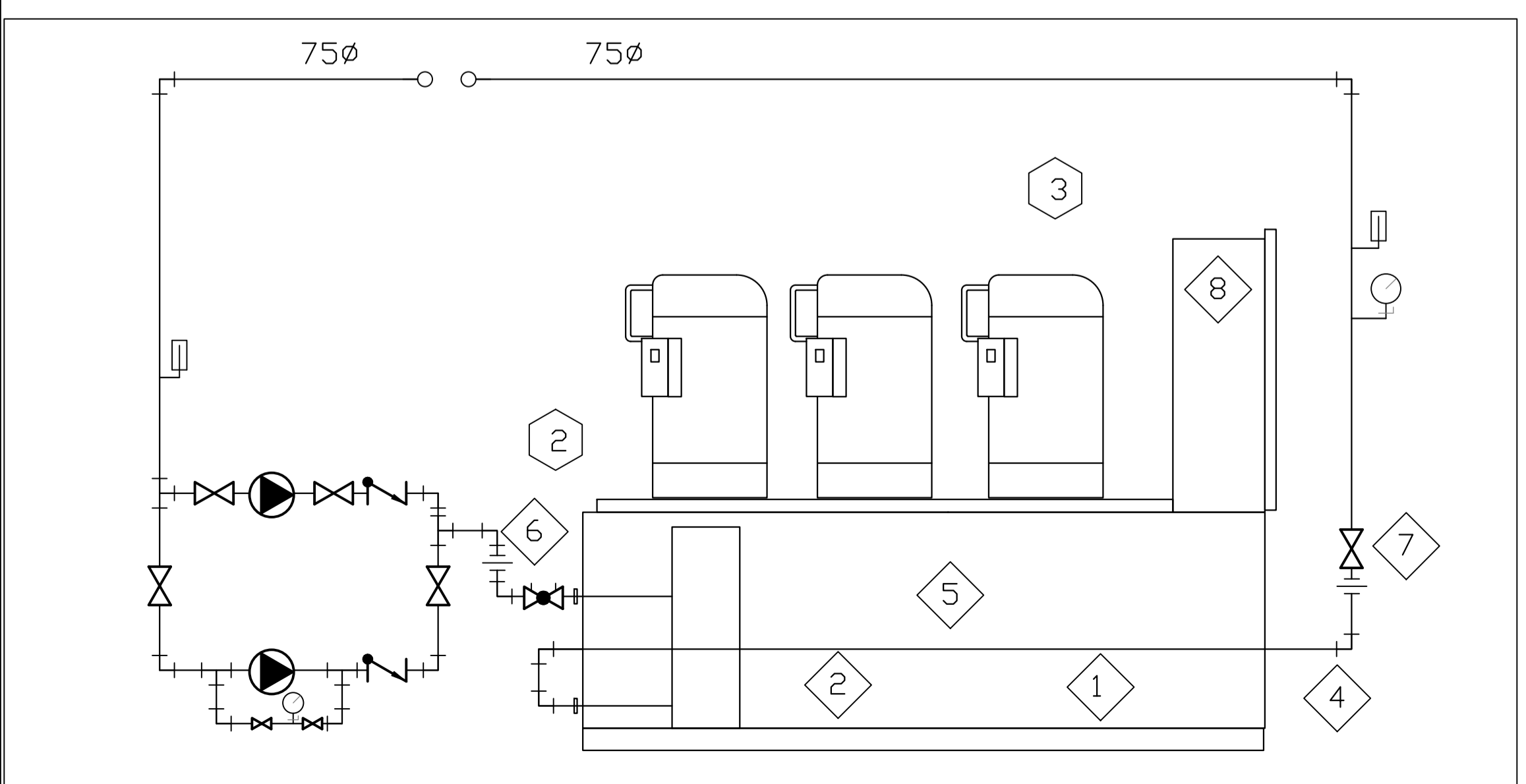

NEW INSTALLATION - SCHEMATIC

- DRAWING NOTES:**
- REMOVE REFRIGERANT FROM EXISTING CHILLER AND CONDENSER OUTSIDE AS PER CODE REQUIREMENTS. PROVIDE REPORT.
 - DRAIN PART OF PIPING LOOP AND CHILLER ISOLATE CHILLED WATER LOOP.
 - REMOVE EXISTING CHILLER.
 - REMOVE TEMPORARILY EXISTING WINDOW (BY CERTIFIED WINDOW INSTALLER) AND HOIST CHILLER THROUGH WINDOW TO OUTSIDE PARKING LOT. REMOVE CHILLER ASAP.
 - REMOVE REFRIGERATION PIPING, DISPOSE AS PER CODE, REMOVE EXISTING CONDENSER.
 - INSTALL NEW CHILLER ON NEW HOUSEKEEPING PAD (100mm THICK), MAKE SURE CHILLER IS AT PROPER LEVEL. REINSTATE WINDOW, MAKE GOOD.
 - INSTALL NEW CHECK VALVES AND BALANCING VALVE. MODIFY PIPING CONNECTIONS TO SUIT NEW CHILLER CONNECTION.
 - PROVIDE NEW BASE RAIL SUPPORT FOR NEW CONDENSER RE-USING EXISTING ROOF CURBS.
 - PROVIDE NEW REFRIGERATION PIPING BETWEEN NEW CHILLER AND NEW CONDENSER AS PER MANUFACTURER'S REQUIREMENTS AND RECOMMENDATIONS. CHARGE WITH NEW REFRIGERANT.
 - REPAIR PIPING THERMAL INSULATION, MATCH EXISTING, MAKE GOOD.
 - BALANCE NEW BALANCING VALVE TO WATER FLOW REQUIRED BY NEW CHILLER.
 - INSTALL NEW ISOLATION BALL VALVE.
 - PROVIDE CONTROLS CONNECTION BETWEEN NEW CHILLER CONTROL PANEL AND BAS. PROVIDE ENABLE/DISABLE AND STATUS OF CHILLER.
 - DISCONNECT EXISTING CHILLER, CONDENSER AND PUMPS (SINGLE CONNECTION FOR PUMPS).
 - PROVIDE ELECTRICAL CONNECTION TO NEW CHILLER (575V, 3 PH, 100A MDCP) RE-USE EXISTING DISCONNECT, REPLACE FUSES WITH NEW 100A AND PROVIDE NEW CONDUCTORS (3X#3-GND - 27mmC) AND CONDENSER (575V, 3PH, 15A MDCP). PROVIDE NEW WEATHERPROOF DISCONNECT SWITCH FOR NEW CONDENSER (30A RATED, NEMA 3R) AND TECK CABLE (3X#12-GND) B/W DISCONNECT AND NEW CONDENSER.
 - PROVIDE NEW LEAD-LAG CONTROLLER, EXTEND EXISTING PUMP (5HP) FEEDER TO NEW CONTROLLER AND CONNECT CONTROLLER TO EXISTING PUMPS. PROVIDE ALL REQUIRED CONDUIT, WIRING AND ASSOCIATED HARDWARE.
- ELECTRICAL:**
- DISCONNECT EXISTING CHILLER, CONDENSER AND PUMPS (SINGLE CONNECTION FOR PUMPS).
 - PROVIDE ELECTRICAL CONNECTION TO NEW CHILLER (575V, 3 PH, 100A MDCP) RE-USE EXISTING DISCONNECT, REPLACE FUSES WITH NEW 100A AND PROVIDE NEW CONDUCTORS (3X#3-GND - 27mmC) AND CONDENSER (575V, 3PH, 15A MDCP). PROVIDE NEW WEATHERPROOF DISCONNECT SWITCH FOR NEW CONDENSER (30A RATED, NEMA 3R) AND TECK CABLE (3X#12-GND) B/W DISCONNECT AND NEW CONDENSER.
 - PROVIDE NEW LEAD-LAG CONTROLLER, EXTEND EXISTING PUMP (5HP) FEEDER TO NEW CONTROLLER AND CONNECT CONTROLLER TO EXISTING PUMPS. PROVIDE ALL REQUIRED CONDUIT, WIRING AND ASSOCIATED HARDWARE.

LEAD-LAG CONTROL PANEL:

- Part 1 -- General**
- 1.01 DEVICE DESCRIPTION
- The system control panel shall consist of a centrally located, pre-programmed microprocessor-based control panel with the capability to coordinate, manage, and operate two circulating pump system serving new chiller.
 - The system control panel shall be CE Mark, CSA and UL 873 recognized.
 - Panel to control 600v/3ph, 5HP circulating pumps.
- Part 2 -- Products**
- 2.01 GENERAL DESCRIPTION
- The system control panel shall be factory tested and assembled and have the capability to operate and manage both circulation pumps.
 - The system control panel shall provide loop control functions for systems with a chiller and two circulating pumps.
 - The system control panel shall accommodate and work in a direct digital control (DDC) type of system operation with chiller controls.
 - The central main logic processing control module shall consist of a controller, preprogrammed and packaged in a NEMA rated enclosure. The panel enclosure shall have a lockable access door to prevent unauthorized access.
 - The system control panel display shall be factory mounted on the front side of the enclosure. The display shall provide access to all operating and configuration parameters in the loop controller panel not limited to but including: pump lead lag control sequence, start/stop/status.
 - The system control panel shall have the capability to include one additional input/output module for extended timeclock control of lead lag function.
- 2.02 OPERATION
- Functional:
 - The system control panel shall coordinate the start and stop of the chilled water loop circulating pumps.
 - The system control panel shall coordinate the shut down of the system in case of fire, loss of water flow.
 - System:
 - The system control panel shall control circulating water pumps to maintain water flow to the chiller based on signal from chiller control panel.
- Part 3 -- Execution**
- 3.01 SEQUENCE OF OPERATION
- General:
 - Circulation pumps shall be directly controlled and monitored by lead/lag control panel receiving start stop signal from chiller control panel.
 - Sequence:
 - Controller logic system shall monitor each pump's differential pressure switch. During day mode, the lead pump shall run continuously. The lag pump shall automatically start on failure of lead pump as determined by differential pressure switch. Controller logic shall permit pumps to change lead/lag upon command from operator's terminal or if lead pump fails during operation.
 - Provide pressure differential switches on each pump. Controller logic shall generate an out-of-normal condition at the controller, resulting in an alarm (after an adjustable time delay) at the operator's terminal when commanded pump fails to start.
 - System user at operator's terminal shall be able to jog pump lead/lag, or be able to schedule automatic jog.
 - Commands / Displays:
 - Provide for each pump, the following commands/displays at operator's terminal:
 - Current pump status (differential pressure switch)
 - Standby pump selection (manually and automatically)
 - Runtime hours accumulation.
 - Water flow, pump failure, and maintenance alarms.
 - Maintenance message generation.
 - Alarm history.
 - Operation trendlogs.
 - Manual/auto (scheduled) command.
 - Manual/auto pump lead/lag jog command.
 - Manual pump alarm reset.
 - Standard factory logic control sequences shall be supplied for loading into controller. Logic sequences shall be field modifiable to provide any necessary site customizations. Factory control programs shall be proportional plus integral type, maintaining maximum accuracy and stability. Controller shall be programmable, either locally or over the BAS network.
 - All control work to be carried out by base building controls contractor in coordination with owner.

1		
0	ISSUED FOR TENDER	2017-11-30
revision		date

project projet

**AGRICULTURE CANADA
CENTRAL EXPERIMENTAL FARM
BUILDING No. 22
CHILLER REPLACEMENT**

OTTAWA, ONTARIO

MECHANICAL & ELECTRICAL EXISTING AND NEW	
designed	L.M.K. conçu
date	OCT 2017
drawn	L.M.K. dessiné
date	OCT 2017
revised	révisé
approved	JRP approuvé
date	OCT 2017
tender	soumission
Project Manager	Administrateur de projets
project no.	no. du projet
	CEF17 0014
drawing no.	no. du dessin
	M/E-1



Appendix "F"

INSURANCE TERMS



INSURANCE TERMS

IN1 GENERAL

- IN1.1 Worker's Compensation
- IN1.2 Indemnification
- IN1.3 Proof of Insurance
- IN1.4 Insured
- IN1.5 Payment of Deductible

IN2 COMMERCIAL GENERAL LIABILITY

- IN2.1 Scope of Policy
- IN2.2 Period of Insurance

IN3 AUTOMOBILE INSURANCE

- IN3.1 Scope of Policy

IN1 GENERAL

IN1.1 Worker's Compensation

- 1) The Contractor shall provide and maintain Worker's Compensation Insurance in accordance with the legal requirements of the Province or Territory where the work is being carried out.

IN1.2 Indemnification

- 1) The insurance required by the provisions of these Insurance Terms shall in no way limit the Contractor's responsibility under the Indemnification clause of the General Conditions of the contract. Any additional coverage the Contractor may deem necessary to fulfill his obligations under the aforesaid clause shall be at his own discretion and expense.

IN1.3 Proof of Insurance

- 1) Before commencement of the Work, and within thirty (30) days after acceptance of its bid, the Contractor shall deposit with Canada a CERTIFICATE OF INSURANCE (form AAFC / AAC5314) available upon request.
- 2) Upon request by Canada, the Contractor shall provide originals or certified true copies of all contracts of insurance maintained by the Contractor pursuant to the provisions contained herein.

IN1.4 Insured

- 1) Each policy shall insure the Contractor and shall include Her Majesty the Queen in right of Canada, represented by the Minister of Agriculture & Agri-Food Canada as an additional Insured, with respect to liability arising out of the operations of the contractor with regard to the work.

IN1.5 Payment of Deductible

- 1) The payment of monies up to the deductible amount made in satisfaction of a claim shall be borne by the Contractor.

INSURANCE TERMS (Continued)

IN2 COMMERCIAL GENERAL LIABILITY

IN2.1 Scope of Policy

- 1) The insurance coverage provided shall not be less than that provided by IBC Form 2100, as amended from time to time, and shall have:
 - (a) an Each Occurrence Limit of not less than \$1,000,000.00 ;
 - (b) a Products/Completed Operations Aggregate Limit of not less than \$1,000,000.00 ; and
 - (c) a General Aggregate Limit of not less than \$2,000,000.00 per policy year, if the policy is subject to such a limit.
- 2) The policy shall either include or be endorsed to include coverage for the following exposures or hazards if the Work is subject thereto:
 - (a) Blasting.
 - (b) Pile driving and caisson work.
 - (c) Underpinning.
 - (d) Removal or weakening of support of any building or land whether such support be natural or otherwise if the work is performed by the insured contractor.
 - (e) Asbestos.
 - (f) Non-owed Automobile Policy.

IN2.2 Period of Insurance

- 1) Unless otherwise directed in writing by Canada, or, otherwise stipulated elsewhere herein, the policy required herein shall be in force and be maintained from the date of contract award until the day of issue of the Certificate of Completion except that the coverage for Completed Operations Liability shall, in any event, be maintained for a period of at least six (6) years beyond the date of the CERTIFICATE OF COMPLETION.

IN3 AUTOMOBILE INSURANCE

IN3.1 Scope of Policy

- 1) Automobile Liability Insurance in respect of licensed vehicles shall have limits of not less than one million dollars inclusive per occurrence for bodily injury, death, and damage to property.



FORMS

CERTIFICATE OF INSURANCE

To be completed by the Insurer

CONTRACT					
Description and location of work					Contract No.
					Project No.
INSURER			BROKER		
Company name			Company name		
Unit/Suite/Apt.	Street number	Number suffix	Unit/Suite/Apt.	Street number	Number suffix
Street name			Street name		
Street type	Street direction	PO Box or Route Number	Street type	Street direction	PO Box or Route Number
Municipality (City, Town, etc.)			Municipality (City, Town, etc.)		
Province/State	Postal/ZIP code		Province/State	Postal/ZIP code	
INSURED			ADDITIONAL INSURED		
Contractor name			Her Majesty the Queen in right of Canada as represented by the Minister of Agriculture and Agri-Food Canada.		
Unit/Suite/Apt.	Street number	Number suffix			
Street name					
Street type	Street direction	PO Box or Route Number			
Municipality (City, Town, etc.)					
Province/State	Postal/ZIP code				
This insurer certifies that the following policies of insurance are at present in force covering all operations of the Insured, in connection with the contract made between the named insured and Her Majesty the Queen in right of Canada, represented by the Minister of Agriculture and Agri-Food Canada.					
POLICY					
Type	Number	Inception date	Expiry date	Limit of liability (\$)	
Commercial General Liability					
Builder's Risk "All Risks"					
Installation Floater "All Risks"					
Other (list)					
Each of these policies includes the coverages and provisions as specified in Insurance Terms and each policy has been endorsed to cover Her Majesty as an Additional Insured. The Insurer agrees to notify Her Majesty and the Named insured in writing thirty (30) days prior to any material change in, or cancellation of any policy or coverage.					
_____			_____		_____
Name of Insurer's Officer or Authorized Employee			Telephone number		Ext.
_____			_____		
Signature			Date		



T4-A CERTIFICATION

The Contractor shall complete and submit this T4-A Certification within fourteen (14) days of Notification of Contract award and within fourteen (14) calendar days immediately following any change to the information already provided under the Contract. Failure to provide this information or failure to provide the correct information shall result a fundamental breach of the Contract.

1. The Contractor shall enter a [x] in one of the boxes below opposite the description that best describe its status.

- A business incorporated either federally or provincially;
- An unincorporated business, either as a sole proprietor or a partnership; or
- An individual.

Note: The information provided in section 2 must correspond with that provided in Section 1.

Corporate or unincorporated business or individual's name: _____

Street Name or Box Number: _____

City, Town or Village: _____

Province: _____

Postal Code: _____

E-mail address: _____

2. Contractor shall complete section 2(a) or 2(b) or 2(c), whichever is applicable to its situation.

a) If incorporated:

Business Number (BN): _____, or
 GST/HST Number: _____, or
 T2 Corporation Tax Number (T2N): _____, whichever is applicable

b) If unincorporated:

Social Insurance Number (SIN): _____, and
 Business Number (BN): _____, or
 GST/HST Number: _____, whichever is applicable

Note: The unincorporated Business Name must be the same as the name associated with the Revenue Canada Business Number or the GST/HST Number.

c) If individual:

Social Insurance Number (SIN): _____, and
 Business Number (BN): _____, or
 GST/HST Number: _____, whichever is applicable

Note: The individual's name must be the same as the name associated with the Social Insurance Number.

- 3. WE HEREBY CERTIFY that I/WE have examined the information provided above, including the legal name, address and Revenue Canada identifier (SIN, BN, GST/HST No., T2N), as applicable, and that it is correct and complete, and fully discloses my/our identification.**

Signature of Contractor

Title of Signatory

Date



SUBCONTRACTING / SOUS-TRAITANCE

If there is to be no subcontracting, proposer must confirm it on this form and sign.
Si aucun sous-traitant ne sera utilisé, l'offrant doit le confirmer sur ce formulaire et le signer.

Contractor's list of subcontractors

It is my/our intention to employ the following subcontractors whom I/we believe, following investigation, to be reliable and competent for the performance of the portion of services being subcontracted. All other services will be performed by me/us.

Liste des sous-traitants de L'entrepreneur

J'ai (nous avons) l'intention de faire appel aux sous-traitants suivants qui, je crois (nous croyons), après avoir effectué une enquête, sont dignes de confiance et compétents pour l'exécution des travaux sous-traités. Je (nous) assurerai tous les autres services.

Nom de l'entreprise / Name of company	Services donnés en sous-traitance / Services to be subcontracted	Nombre d'années en association avec ce sous-traitant / Number of years that you are associated with that subcontractor	Nombre d'années d'expérience du sous-traitant dans ce domaine / Years of experience of subcontractor in the field	Portion du contrat (%) / Portion of the contract (%)

Je m'engage (nous nous engageons) à ne pas confier d'autres services en sous-traitance à des personnes ou à des sociétés, à moins d'obtenir l'autorisation écrite du ministre de l'Agriculture

It is agreed that I (we) shall not subcontract with any other individual or organization or for any other work, without the consent of the Minister of Agriculture

Name

Position

Signature

Date



FORMER PUBLIC SERVANT – STATUS AND DISCLOSURE

Contracts with former public servants (FPS) in receipt of a pension or of a lump sum payment must bear the closest public scrutiny, and reflect fairness in the spending of public funds. In order to comply with Treasury Board policies and directives on contracts with FPS, bidders must provide the information required below.

Definitions

For the purposes of this clause, "former public servant" is any former member of a department as defined in the Financial Administration Act, R.S., 1985, c. F-11, a former member of the Canadian Armed Forces or a former member of the Royal Canadian Mounted Police. A former public servant may be:

- a. an individual;
- b. an individual who has incorporated;
- c. a partnership made of former public servants; or
- d. a sole proprietorship or entity where the affected individual has a controlling or major interest in the entity.

"lump sum payment period" means the period measured in weeks of salary, for which payment has been made to facilitate the transition to retirement or to other employment as a result of the implementation of various programs to reduce the size of the Public Service. The lump sum payment period does not include the period of severance pay, which is measured in a like manner.

"pension" means, a pension or annual allowance paid under the Public Service Superannuation Act (PSSA), R.S., 1985, c.P-36, and any increases paid pursuant to the Supplementary Retirement Benefits Act, R.S., 1985, c.S-24 as it affects the PSSA. It does not include pensions payable pursuant to the Canadian Forces Superannuation Act, R.S., 1985, c.C-17, the Defence Services Pension Continuation Act, 1970, c.D-3, the Royal Canadian Mounted Police Pension Continuation Act, 1970, c.R-10, and the Royal Canadian Mounted Police Superannuation Act, R.S., 1985, c.R-11, the Members of Parliament Retiring Allowances Act, R.S., 1985, c.M-5, and that portion of pension payable to the Canada Pension Plan Act, R.S., 1985, c.C-8.

Former Public Servant in Receipt of a Pension

As per the above definitions, is the Bidder a FPS in receipt of a pension? Yes () No ()

If so, the Bidder must provide the following information, for all FPS in receipt of a pension, as applicable:

- a. name of former public servant;
- b. date of termination of employment or retirement from the Public Service.

By providing this information, Bidders agree that the successful Bidder's status, with respect to being a former public servant in receipt of a pension, will be reported on departmental websites as part of the published proactive disclosure report.

Work Force Reduction Program

Is the Bidder a FPS who received a lump sum payment pursuant to the terms of a work force reduction program? Yes () No ()



If so, the Bidder must provide the following information:

- a. name of former public servant;
- b. conditions of the lump sum payment incentive;
- c. date of termination of employment;
- d. amount of lump sum payment;
- e. rate of pay on which lump sum payment is based;
- f. period of lump sum payment including start date, end date and number of weeks;
- g. number and amount (professional fees) of other contracts subject to the restrictions of a work force reduction program.

For all contracts awarded during the lump sum payment period, the total amount of fees that may be paid to a FPS who received a lump sum payment is \$5,000, including the Goods and Services Tax or Harmonized Sales Tax.

Name

Signature

Date