

Serving  
**GOVERNMENT,**  
Serving  
**CANADIANS.**

# **PWGSC Commissioning Manual (CP.1)**

**4<sup>th</sup> edition  
November 2006**

Prepared by  
**National Commissioning Committee**

Issued by  
**Real Property Branch**

## GENERAL

### Development

This document has been developed under the direction of Mechanical and Maintenance Engineering, AES with the participation and contributions of the following members of the National Commissioning Committee:

Edward Durand	NCA
Paul Sra	NCA
Mike Cavan	NCA
Ralph Collins	NCA
John Hutchins	Pacific Region
Stuart Davison	Western Region
John Lee	Ontario Region
Yvon Rajotte	Quebec Region
Michael Devine	Atlantic Region

### Feedback

Corrections, recommendations, suggestions for modifications or additional information and instructions that will improve this document are invited. For this purpose the attached form entitled "*Request for change to this manual*" may be used and mailed or faxed to the address shown. E-mail or other forms of electronic transmission may also be used for this purpose.

### Conflicts

Any area of conflict between this document and the Project Brief must be brought to the attention of the Project Manager as soon as it is noted.

**PWGSC COMMISSIONING MANUAL (CP.1)**

**4th edition  
November 2006**

**Request for changes to this manual**

**Return this form to :**

National Manager  
Mechanical and Maintenance Eng. Group  
Architectural and Engineering Resources  
Professional and Technical Program  
Real Property Branch  
PWGSC  
Tel: (819) 956-3972 FAX: (819) 956-4441

**Type of change suggested:** Please indicate which applies:  
1. Correction of information  
2. Deletion of information  
3. Additional information to be added

**Details of suggested changes:** If necessary, make the suggested changes to a photocopy of the relevant page(s) of this manual and attach to this sheet.

Page:            Chapter:            Paragraph no:

**Details of suggested changes**

(Use additional sheets if necessary)

Signature: \_\_\_\_\_ Date: \_\_\_\_\_

## **Preface to the 4th edition - November 2006**

In 1977, a Building Commissioning Section was established in the Facilities Maintenance Division of the former Property Administration Branch of the former Public Works Canada (now Public Works and Government Services Canada [PWGSC]). This Building Commissioning Section recognised the need for early involvement in the Project Delivery System (PDS) but faced two big obstacles. On its own part, there was a lack of practical experience in commissioning; on the part of the design community, there was a certain resistance to change in the status quo.

In 1987 a Buildings Commissioning Working Group was formed in the, then, Architectural and Engineering Services Branch (AES) at Headquarters and included representatives from the Facilities Maintenance Division. Its mandate was to establish a clear understanding of commissioning, to define its objectives, and to establish the technical requirements for commissioning mechanical and electrical systems in buildings for inclusion in project briefs. This working group was determined to provide a "seamless" approach to commissioning. Research on the subject included examination of source documents and practices from the United States (including ASHRAE), the United Kingdom and Australia. When the working group examined current practices in Canada, it became clear that commissioning, as it was then defined in the PWGSC six-phase Project Delivery System, was rarely carried out. One reason for this was that responsibility and accountability for commissioning had not been clearly identified.

In February 1989, the working group produced a series of draft commissioning documents. In 1991 these documents were further refined, developed to cover all disciplines and consolidated into one manual - *The Project Commissioning Manual*, produced in 1993.

A continuation of this initiative resulted in further refinements, the development of generic commissioning briefs and commissioning specifications and the release of CP.1 - *"The Project Commissioning Manual - Revised January 2000"*.

In 2000, a National Commissioning Committee was established. Its membership included representatives from AES and AFMS and was co-chaired by the Director/Manager of these groups. Its terms of reference included, among other things:

1. To review, improve and update commissioning documents
2. To develop new commissioning practices
3. To create, maintain and update commissioning information database.
4. To promote commissioning in PWGSC
5. To prepare "Lessons Learned" documentation
6. To organize annual commissioning workshops
7. To receive, evaluate and share information and experiences with the Regions.

As a result of the work of this committee, further changes were made to the manual in order to make it even more easily referenced by Project Managers, Commissioning Managers and others. The Commissioning Manual now consists of two binders:

- ***PWGSC Commissioning Manual*** - addresses the requirements of the Commissioning Policy and includes issues which are of major concern to the PWGSC Project Manager and the Project Leader.
- ***PWGSC Commissioning Guidelines*** -contains the remaining documents and is generally for the benefit of in-house designers, consultants and their sub-consultants and Commissioning Managers.

In 2006, the PWGSC Project Delivery System (PDS) was changed to the National Project Management System (NPMS). The Commissioning Manual and Guidelines were subsequently modified to suit the NPMS and its terminology.

*The PWGSC Commissioning Manual* and the *PWGSC Commissioning Guidelines* have been structured so that each Region is able to adapt them to suit regional requirements, since it is recognized that each Region has a different approach to the practice of commissioning and that this will affect how each uses the *PWGSC Commissioning Manual*. It is suggested that each Region select from the *PWGSC Commissioning Guidelines* those elements which are most applicable to the Region's requirements and that will enable each Region to develop a quality deliverable which is acceptable to the Client.

It is also recognized that the organizational structure of each Region is unique and subject to change. *The PWGSC Commissioning Manual (CP.1)* has therefore been written around commissioning activities and is not reliant upon the reporting organizational structures of the PWGSC Regions.

It is suggested that each Region develop its own partnership agreement between the relevant branches of PWGSC relating to roles and responsibilities throughout the commissioning process so as to reflect the distinctive organizational structure of each Region. It will also promote commissioning as a tool for enhancement of client satisfaction.

### **Partnership between all branches of PWGSC**

The role of PWGSC in commissioning and in the production of the PWGSC Commissioning Manual and the accompanying PWGSC Commissioning Guidelines has always been fully recognized by all branches of PWGSC.

Architectural and Engineering Resources will continue to provide national leadership for commissioning, while AFM will continue to provide management of the overall commissioning activities as it relates to specific projects.

It is also recognized that PWGSC, through its Design Quality Review Team, has a very important role to play in the identification of Design Criteria, Design Intents, Design

Assumptions and Design Solutions to meet these Design Criteria. It is also recognized that commissioning can be properly delivered only by combining the design expertise of Architectural and Engineering Resources and the operational expertise of Maintenance and Operational Assurance (MOA) Commissioning Manager in NCA, and the Maintenance Management Commissioning Manager in the Regions.

### **Future Developments**

As noted above, the National Commissioning Committee will continue to direct and advise on all matters relating to commissioning.

Future editions of this manual will include experiences gained from commissioning activities in PWGSC Regions, as well as knowledge gained from the professional community and from the construction industry. This is essential to the provision of an up-to-date, viable and useful Project Commissioning Manual.

Since the issuance of this manual, generic Installation/Commissioning Checklists and Product Information (PI) and Performance Verification (PV) Report Forms have been developed and proven by use on a number of projects. These are currently being reviewed to improve format and content. This is a long process and will form part of future developments.

### **Regional Commissioning Contacts**

For specific commissioning services in your region, please contact [SNGP.NPMS@tpsgc-pwgsc.gc.ca](mailto:SNGP.NPMS@tpsgc-pwgsc.gc.ca).

### **Acknowledgements**

This manual has been based on many consultations with all branches of PWGSC, many other government departments, organizations such as ASHRAE, the private sector, and many private individuals having a great deal of expertise in commissioning. We wish to thank all those who responded and to assure them that all comments and suggestions provided were carefully examined and, where deemed appropriate, incorporated into the manual. It is only through such co-operation that the best possible document can be produced.

# PWGSC Commissioning Manual (CP.1)

## Table of Contents

(in this binder)

### **Chapter 1: General requirements**

- 1.1 Introduction
- 1.2 Commissioning
- 1.3 Commissioning requirements
- 1.4 Objectives of commissioning
- 1.5 Risks of inadequate commissioning
- 1.6 Benefits of commissioning
- 1.7 Extent of commissioning
- 1.8 Costs of commissioning
- 1.9 Commissioning of a facility
- 1.10 Project teams
- 1.11 Roles and responsibilities - General comments
- 1.12 Roles and responsibilities - Traditional design capital construction projects
- 1.13 Roles and responsibilities - Smaller design-construction projects
- 1.14 Roles and responsibilities - Design-build projects
- 1.15 Roles and responsibilities - AFD-managed facilities - Projects over \$200K.

### **Chapter 2 Commissioning documentation**

- 2.1 Introduction
- 2.2 Project archives
- 2.3 Commissioning documentation package
- 2.4 Investment Analysis Report (IAR)
- 2.5 Request For Proposal (RFP)
- 2.6 Functional requirements and operational requirements
- 2.7 Design criteria
- 2.8 Commissioning Brief
- 2.9 Conceptual Design Report
- 2.10 Detailed design development
- 2.11 Working documents
- 2.12 Commissioning specifications
- 2.13 Commissioning Plan
- 2.14 Installation/Start-up Check Lists
- 2.15 Product Information (PI) and Performance Verification (PV) report forms
- 2.16 Commissioning of heritage Buildings
- 2.17 Building Management Manuals
- 2.18 Commissioning reports

- 2.19 Final Commissioning (Evaluation) report
- 2.20 Other documents

**Appendix A Samples of commissioning documentation**

**Appendix B Commissioning Glossary (CP.2)**

## **PWGSC Commissioning Guidelines**

(in separate binder)

<i>CP.3 Guide to the development of the Commissioning Plan</i>	3rd Edition Nov.2003
<i>CP.4 Guide to the development of Building Management Manuals</i>	3rd Edition Nov.2003
<i>CP.5 Guide to the preparation of Training Plans</i>	3rd Edition Nov.2003
CP.6 Reserved for future development	
<i>CP.7 Design guideline for facility operation and maintenance</i>	3rd Edition Nov.2003
<i>CP.8 Guide to the preparation of Commissioning Reports</i>	3rd Edition Nov.2003
<i>CP.9 Guide to the development and use of Check lists</i>	3rd Edition Nov.2003
<i>CP.10 Guide to the development and use of Report Forms and Schematics</i>	3rd Edition Nov.2003
<i>CP.11 Guide to the preparation of Commissioning Briefs</i>	3rd Edition Nov.2003
<i>CP.12 Guide to the development and use of Generic Commissioning Specifications</i>	3rd Edition Nov.2003
<i>CP.13 Facility Maintenance Policy, Guidelines and Requirements</i>	3rd Edition Nov.2003

All rights reserved. No part of this information may be reproduced or transmitted in any form or by any means, electronic, mechanical, photocopying, recording or otherwise, or stored in a retrieval system without prior written permission of the Minister of Public Works and Government Services, Ottawa, Ontario, Canada K1A 0S5



# PWGSC Commissioning Manual (CP.1)

## Chapter 1 General requirements

### 1.1 Introduction

This manual is for the use of the PWGSC Project Leader, Project Manager, Commissioning Manager and designers in order to give them a clear understanding of commissioning and to provide guidance in the implementation of commissioning to all PWGSC projects.

In addition, this manual will assist members of the Project Team and personnel from client departments representing the occupants' interests in applying the principles of commissioning as described in this manual.

In addition to this manual, there are various commissioning guidelines for the implementation of commissioning. These guidelines are referenced in the preface to this document.

The PWGSC Commissioning Manual provides detailed information on commissioning as an integral part of the National Project Management System (NPMS) and outlines a clear and consistent approach to commissioning for all members of the Project Team in all stages of NPMS .

Commissioning applies to all PWGSC projects including new projects and renovations, leased premises, AFD-managed facilities, Design-build projects and fit-ups.

### 1.2 Commissioning (Cx)

Commissioning is a planned program of activities that advances built works from the earliest phases of the project identification stage to a condition of full operation, meeting all objectives of commissioning as defined herein. The commissioning process starts in NPMS Project Identification stage with the production of the Investment Analysis Report (IAR) and ends when the delivered, fully occupied facility has been proven to operate satisfactorily under all weather and occupancy conditions and the Evaluation Report has been written and accepted. Commissioning addresses not only technical systems requirements and the functional and operational needs of the occupants and the Owner including health and safety, security, comfort, and cost effectiveness of operations and maintenance but also protection of the architectural character of new buildings and the heritage character of historical buildings.

Much like the commissioning of ships, commissioning of buildings ensures that when the built works are handed over to its owner occupant or operator as an operating entity it will meet all requirements as described in the Request for Proposal (RFP) or the Project

Brief. It requires coordinated efforts on the part of the Project Planning Team, the Design Team, the Commissioning Team, the Construction Team and the Project Management Team.

During construction, **commissioning** applies to the implementation phase of the NPMS Project Delivery stage in which system and environmental performances are verified, and the project is moved from a static form to a dynamic state and the facility is accepted for occupancy. Commissioning:

- provides a bridge between construction activities and ongoing operation and maintenance,
- provides the necessary technology transfer (training) tools for O&M activities to be performed properly for the entire service life of the facility,
- focuses on the operation of all systems as an integrated whole and verifies the performance and interaction of all systems operating together under a full range of operating conditions with simulated full occupancy.

### **1.3 Commissioning requirements**

All PWGSC construction projects shall undergo a commissioning process as outlined in this manual.

### **1.4 Objectives of commissioning**

The objectives of commissioning are to:

- .1 document the design intent of the overall project, including the architectural characteristics (in the case of new buildings), protection of the heritage features and character (in the case of historical buildings) and the proposed building systems and components and to verify and demonstrate that all functional and operational requirements have been correctly interpreted in the design solution.
- .2 minimize O&M costs through the careful selection of design solutions (for economy, reliability, durability, accessibility, maintainability, etc.), construction materials, installation practices and performance verification procedures.
- .3 verify that selected design solutions and the resultant built works protect the safety, health, welfare and comfort of occupants and O&M personnel.
- .4 define responsibility areas for meeting these operational requirements in the contract documents and include a process to demonstrate compliance.
- .5 demonstrate that the client's and the department's requirements are met during the project implementation and commissioning phases of the project and to support quality management of construction and installation through verification of building components, systems and environments.
- .6 verify and demonstrate that all systems operate consistently at peak efficiencies, under all normal load conditions, and within the specified energy budget.
- .7 provide comprehensive documentation of the operational, maintenance and building management.
- .8 implement a comprehensive training program.
- .9 transfer the completed works to qualified and trained facility operators.

## 1.5 Risks of inadequate commissioning

There is an inherent risk that certain penalties are likely to result from a poorly commissioned facility. The Owner/Investor, represented by the Project Leader, must weigh the costs of good commissioning practices against the risks of inadequate commissioning. Such risks and penalties might include:

***Impact on heritage character of historical buildings:*** *Inadequate training and information could result in inadequate attention to protection of heritage character and design intent.*

***Unclear design criteria and design intents:*** These lead to inability to meet project and client requirements and failure to meet federal government objectives.

***User discontent:*** Facility occupants may suffer discomfort or inconvenience as a result of inadequate commissioning. This can lead to complaints to the Owner/Investor, costly remedial measures or loss of clientele.

***High O&M costs:*** Inadequate training of O&M staff, poor system documentation or limited performance verification procedures may result in higher utility and O&M costs over the life of the facility (a factor of significant proportions to the Property Manager.)

***Inappropriate maintenance practices:*** Maintenance is likely to be inappropriate when O&M staff have not been fully involved in commissioning activities, resulting in under- or over-maintenance. Either of these will cause unnecessary higher life-cycle costs.

***Possible injury:*** Insufficient protection of system components, not revealed in thorough commissioning, could expose O&M personnel to unnecessary danger.

***Expensive corrective measures:*** High costs and/or major difficulties in retrofitting so as to correct problems which could have been small (or avoided altogether) if addressed during planning or design.

## 1.6 Benefits of commissioning

***Protection of heritage character:*** The training and documentation provided and involvement of O&M staff in commissioning is the basis for informed maintenance that is sensitive to the needs of heritage materials and assemblies.

***Reduced life-cycle costs:*** In the long term, the projected life-cycle costs of buildings and facilities will be reduced as a result of the integrated efforts of the Designer and the building operators to meet commissioning requirements. When building quality is translated into higher productivity and reduced absenteeism of the occupants, the overall savings become even more significant.

***More cost-effective maintenance:*** Involvement of O&M staff in commissioning, plus the training and documentation provided, is the basis for more effective operation, maintenance and management throughout the life of the facility.

***Knowledge transfer:***

- .1 Systematic development of commissioning documentation facilitates knowledge transfer from one phase of delivery to the next and from the delivery process to the ensuing ongoing operation of the facility.
- .2 Feedback through project management and report mechanisms can provide benefits to other projects by reporting on experience gained through the Validation and Acceptance Process.

***Occupant satisfaction:*** The primary and immediate beneficiaries of a properly designed, constructed and commissioned facility are the occupants. They will enjoy the advantages of living or working in comfortable, safe, pleasant and properly functioning surroundings that meet their everyday needs. Further benefits will accrue to the Owner/Investor as a result of having satisfied tenants in a quality building that complies with the requirements of the investment plan.

***Quality assurance:*** The Owner/Investor is assured that a quality facility and a "surprise-free" product/environment have been provided. This will be achieved by ensuring that:

- .1 the contract documents include all commissioning specifications,
- .2 the requirements of these specifications will be met,

Fully documented tests and inspections will prevent minor errors from developing into serious operational flaws.

***System documentation:*** Provision of accurate and useful historical records is assured. Such records provide important data for O&M efforts as well as for future renovations, upgrades or repairs. Technical reports and other commissioning documents serve as benchmarks for future system testing, re-commissioning and for maintenance or renovation activities.

***System performance verification:*** Commissioning extends into the project delivery stage, close-out phase, in order to verify performance under a full range of operating conditions. This practice aims to provide a "no-surprises" operation cycle for both Owners and O&M staff. A thorough process will help to avoid unforeseen or hidden O&M expenses later.

***LEED and BREEAM certification:*** Commissioning as performed in accordance with *the PWGSC Commissioning Manual (CP.1)* and its associated *PWGSC Commissioning Guidelines* will meet or exceed the fundamental and additional requirements of various programs such as Leadership in Environmental and Energy Design (LEED), Building Research Establishment Environmental Assessment Method (BREEAM), Quality Guideline C2000 and enable the project to obtain the appropriate certification.

## **1.7 Extent of commissioning**

The extent of commissioning is determined through discussions among all stakeholders such as the Project Leader, Project Manager and Commissioning Manager and is then defined in the Commissioning Brief and the Request for Proposal (RFP) document.

On the other hand, there is a cost associated with insufficient commissioning (refer to 1.5 "*Risks of Inadequate Commissioning*", above).

A detailed guideline relating to the extent of commissioning is contained in *CP.11: "Guide to the preparation of Commissioning Briefs"*.

## **1.8 Costs of commissioning**

Many commissioning activities detailed in this manual and the supporting documentation are already being performed as normal standard practice and do not constitute extra costs. Other commissioning activities, traditionally not provided by the design and construction industry, represent additional responsibilities for the Project Manager, Designer and Contractor.

In balance, there will undoubtedly be some additional initial costs to carrying out commissioning procedures. These will depend upon the degree of risk of non-compliance with the occupant's requirements or the life-cycle quality and cost plan the Owner is prepared to undertake. Experience to date indicates that full commissioning adds between 1% and 4% to the mechanical and electrical construction cost of projects. These extra costs can be attributed to the provision of services not usually included in design and construction projects, such as consultations between design and property management personnel; more intensive site services; more extensive systems documentation; and enhanced O&M documentation and training.

It has often been observed that O&M costs during the first year of operation are 50% to 150% higher than during following years. Experience, however, also indicates that the cost of commissioning is more than recovered through reduced O&M costs during this initial year of operation.

Increases in project costs attributable to commissioning may be summarized as follows:

1. Costs due to the Designer's involvement in:
  - a. Preparation of a Commissioning Plan,
  - b. Preparation of enhanced O&M documentation,
  - c. Preparation of test protocols for inclusion in project specification,
  - d. Increased involvement in site inspections and testing during construction,
  - e. Greater involvement in commissioning,
  - f. Responsibilities for, and involvement in, training,
  - g. Prolongation of involvement during the warranty period.

2. Costs due to the involvement of PWGSC Design Quality Review Team and the PWGSC Project Commissioning Team in:
  - a. Activities related to preparation and review of commissioning briefs,
  - b. Review of Commissioning Plan,
  - c. O&M design reviews,
  - d. Review of commissioning specifications,
  - e. Installation and commissioning inspections,
  - f. Performance verification testing,
  - g. Review of Building Management Manual and other commissioning documentation,
  - h. Commissioning.
  
3. Costs to the Contractor due to:
  - a. Refinement of Commissioning Plan and preparation of Commissioning Schedule
  - b. Greater involvement in training of O&M personnel,
  - c. Temporary instrumentation for commissioning,
  - d. More intensive involvement in performance verification for commissioning,
  - e. The hiring of a qualified Commissioning Agent,
  - f. Prolongation of involvement during the Warranty Period.

The exact amount will depend on a variety of factors such as the size, location and complexity of the facility and its systems and the extent of commissioning required. For instance, a research laboratory with stringent air quality and ventilation requirements will necessitate more extensive and costly commissioning than a general-purpose warehouse. Early involvement of the Commissioning Manager to help prepare the Commissioning Plan and Budget will be instrumental in achieving control over the costs of commissioning.

## **1.9 Commissioning of a facility**

An operational facility can be regarded as the architectural building (including, if necessary, its heritage characteristics) a number of integrated systems, each of which delivers a functional environment such as indoor air, visual environment, operational services, security, or emergency services. Each integrated system and its resultant environment is achieved through the proper operation of systems, subsystems, equipment and components which, together, form the integrated system.

The functional environment referred to in Figure 1 below should include any special environmental goals such as those required by Heritage buildings.

The interaction of the system hierarchies is illustrated in Figure 1.

1.10

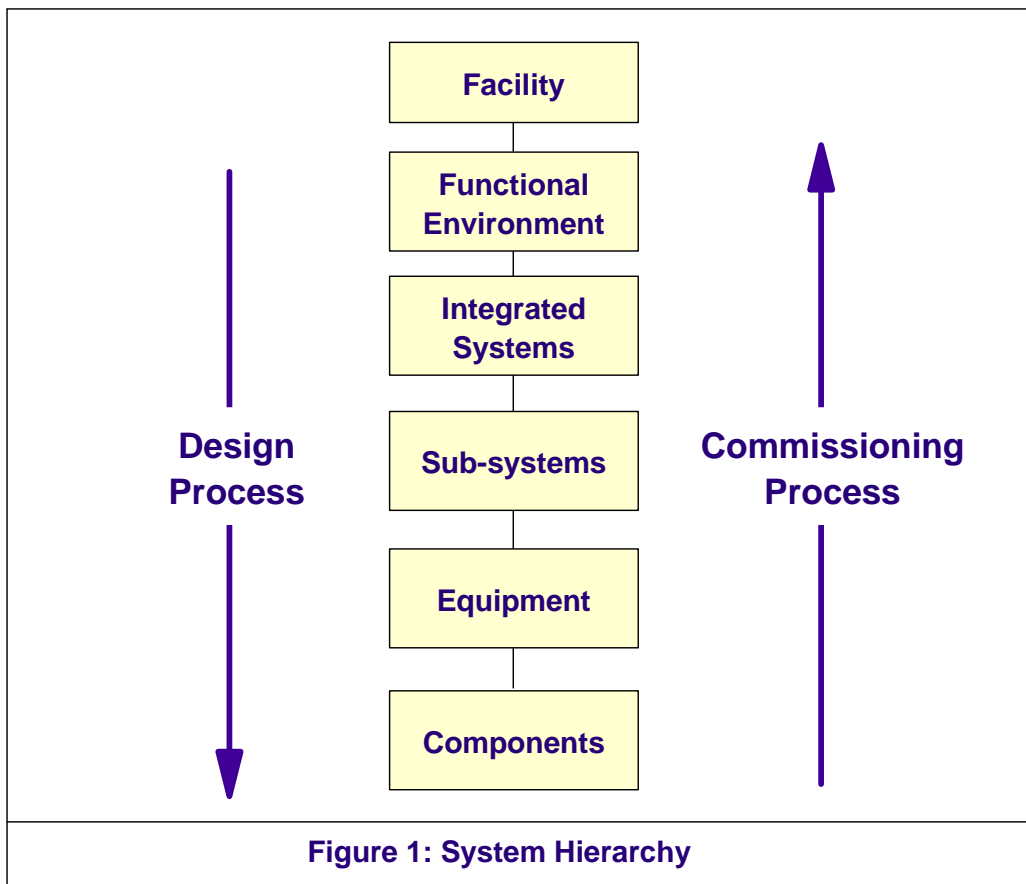

### Project teams

The team structure for a typical moderate to large project may be comprised of the following project teams.

The make-up of each team varies according to the type, size and complexity of the project. Project team members may participate in one or more teams.

1. ***The Project Planning Team*** is assembled for the purpose of developing an Investment Analysis Report (IAR) and consists of the Project Leader, Project Manager and others involved in the preparation of the IAR.

2. ***The Project Design Team*** consists of the Design Coordinator, the PWGSC Design Quality Review Team, the Commissioning Manager and Architectural, Structural, Mechanical and Electrical Designers. The PWGSC Design Quality Review Team consists of engineers and specialists from all disciplines within PWGSC and is selected by the Project Manager. The Project Design Team is usually engaged by the Project Manager through business agreements, usually (but not always) at the end of the NPMS project identification stage, and usually continues to work as a team until the end of the project delivery stage, close out phase.
3. ***The Project Commissioning Team*** consists of (as appropriate during project delivery) the Project Design Team, the Project Construction Team, the Property Management Team and the Commissioning Manager. The Project Commissioning Team is usually represented by the Commissioning Manager starting during the project identification stage, analysis phase, or, the project delivery stage, planning phase. As design and construction proceeds, other players form part of the team insofar as their responsibilities relate to commissioning. The Project Commissioning Team reaches peak involvement at the project delivery stage, implementation phase.
4. ***The Project Construction Team*** consists of the Contractor, sub-trades, manufacturers and suppliers. The Project Construction Team is usually engaged following successful bidding on the project and being awarded the construction contract. This team usually completes its work at the end of the project delivery stage, implementation phase, when the completed project is passed to the Property Management Team for operation. The services of the Project Construction Team is required during the project delivery stage, close out phase for post- construction commissioning and to address all deficiencies.
5. ***The Property Management Team*** receives the facility and operates it throughout its useful life, consists of (as appropriate during project delivery) the Property Manager, the O&M staff, Service Contractors, the Project Design Team, the Project Construction Team and the Commissioning Manager.
6. ***The Evaluation Team***, is assembled for the purpose of conducting post-occupancy evaluation as defined in the project delivery stage, close out phase, and shall include, but not necessarily be limited to the Project Leader, the Project Manager and the Commissioning Manager..

#### **1.11 Roles and responsibilities - General comments**

Commissioning is an integrated team effort among all parties involved in the project. It demands full cooperation in all stages of planning, design, construction, installation, activation and performance verification and operation. It also requires clear communications among all parties to achieve understanding of all requirements. This includes full documentation of major decisions and activities.



Successful delivery of a satisfactory project will be achieved only by a well-informed project management group. Similarly, successful delivery of accommodation satisfying User needs can only be achieved by a properly trained property management team that has all the tools to operate and maintain the facility.

The following paragraphs provide roles and responsibilities for the four major types of construction projects used by PWGSC:

\*\* 1.12 Roles and responsibilities - Traditional Design Capital Construction Projects

\*\* 1.13 Roles and responsibilities - Smaller Design Construction Projects

1.14 Roles and responsibilities - Design-Build Projects

1.15 Roles and responsibilities - AFD Managed Facilities - Projects over \$200K.

\*\* The decision as to which of these shall apply depends upon discussions relating to the type, size, and complexity of the project.

## 1.12 Roles and responsibilities - Traditional design capital construction projects

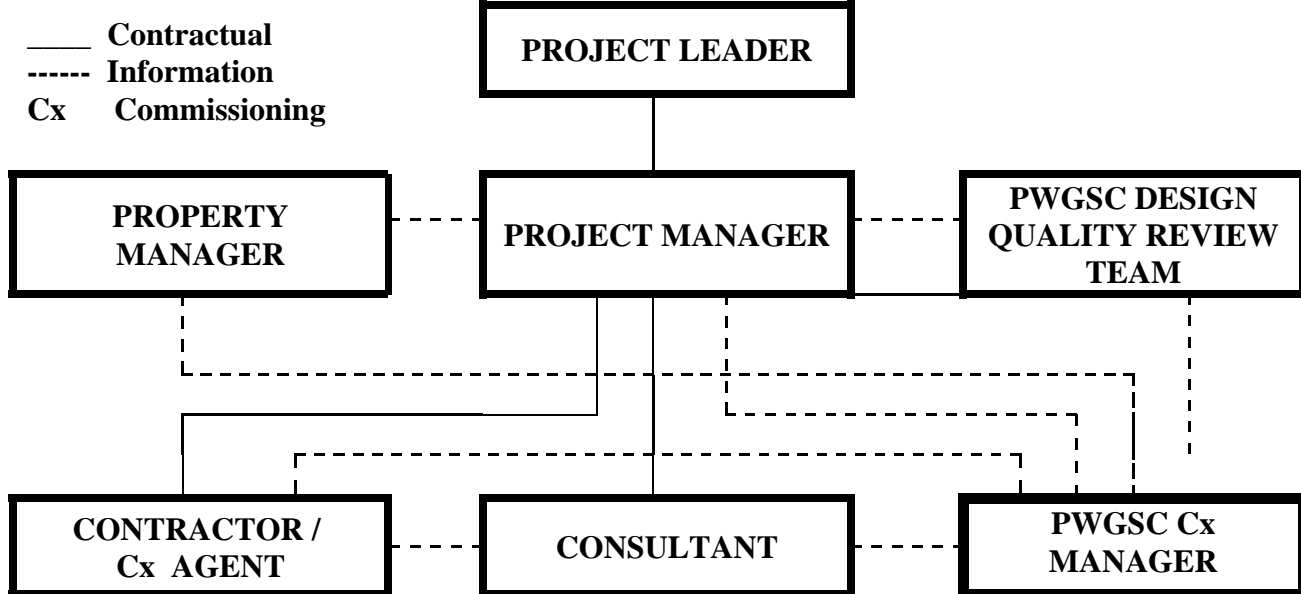

**NOTE: The above is an example ONLY. Stakeholders should refer to the project-specific communications and organization structure as established by the Project Manager.**

### Definition:

**Traditional Design Capital Construction Projects** may be defined as new projects, renovations and fit-ups for the installation of components, equipment, subsystems, systems and/or integrated systems which are complex and large in scope.

**The Project Leader** is responsible for initiating the project on behalf of the Owner/Investor, for accepting the facility from the Project Manager and for handing it over to the Property Manager for operation. The Project Leader is also responsible to securing approved project funding.

**The Project Manager** has overall responsibility for managing the project, and for demonstrating to the Project Leader that the installed systems and overall facility meet the requirements defined in the Project Brief.

**PWGSC Design Quality Review Team:** reviews all aspects of design from development of the RFP to Conceptual Design Report, agreement with proposed design solutions, quality assurance, quality control, quality management, detailed design, working documents, and the final evaluation including value for money, adherence to standards.

**PWGSC QA Commissioning Manager:** provides planning and technical advice on O&M matters, coordinates commissioning activities from project identification to close out phase; ensures O&M concerns are addressed, provides quality assurance and reviews commissioning

documentation at all stages of project delivery including accuracy of Product Information (PI), Performance Verification (PV) and commissioning reports. Communications between the Commissioning Manager, the Designer and the Contractor is through the Project Manager. The Project Manager may delegate authority to the Commissioning Manager in matters relating to commissioning, while retaining overall responsibility for the project.

**Consultant (Designer):** refers to the private sector consultant with its internal commissioning resources or a firm having experience in commissioning and to in-house designers. The Consultant develops the Commissioning Plan, design intent, proposed design solutions, prepares commissioning specifications, building management manual, and other commissioning documentation, develops training plan, witnesses and certifies performance of all commissioning activities and organizes and monitors all activities as per the Contract Agreement, and is responsible for its contractual design, construction, and warranty-related commitments. The appointment of a Commissioning Manager does not permit the Consultant to abrogate traditional contracted professional responsibilities (e.g. site supervision and ensuring that construction conforms to the design intent).

**The Contractor/Commissioning Agent:** carries out many start-up and performance verification activities and carries out demonstrations and acceptance tests and related procedures. He acts as a coordinator only in matters relating to commissioning, refines the Commissioning Plan develops the Commissioning Schedule, coordinates all commissioning activities in accordance with contract documents, including all tests for equipment, systems and integrated systems and provides required documentation. The Contractor identifies both the site coordinator and the Commissioning Agent.

**The Property Manager** represents the Operator and is responsible for the day-to-day management and operation of the completed facility after it has been accepted from the Project Leader. During commissioning, he consults with the Project Manager on the acceptability of the facility, including training and documentation, before accepting the project for operation.

**SAMPLE1**

**Commissioning services - Traditional Design Capital Construction Projects**

**Designer** may be either in-house Designer or private sector Consultant with his own commissioning resource person or a commissioning firm

**NOTE: All stakeholders must follow communications plan as established by the Project Manager**

4th edition - July 2006

Copyright reserved

<b>Commissioning services - TRADITIONAL DESIGN CAPITAL CONSTRUCTION PROJECTS</b>					
<b>Project Leader (PL) Project Manager (PM) responsibilities</b>	<b>PWGSC Design quality review team responsibilities</b>	<b>Designer - (Consultant responsibilities</b>	<b>PWGSC QA Cx Manager responsibilities</b>	<b>Contractor responsibilities</b>	<b>Deliverables</b>
<b>NPMS Project Identification Stage, Analysis Phase</b>					
Project Leader prepares IAR					IAR
PL identifies & BUDGETS FOR Cx in IAR			Provides input into Commissioning Budget		Commissioning budget
<b>NPMS Project Delivery Stage, Planning Phase</b>					
Project Mgr.. develops RFP including commissioning	Provides design input into RFP		Provides input into RFP		Request for Proposal (RFP) and Project Brief
<b>NPMS Project Delivery Stage - Design Phase</b>					
	Reviews DESIGN CRITERIA, FUNCTIONAL REQ'TS	Establishes Design Criteria, functional & Operational requirements	Reviews OPERATIONAL REQUIREMENTS		Design Criteria, Functional Req'ts, Operational Req'ts
		Establishes PRELIMINARY O&M BUDGET	Reviews Preliminary O&M budget		Preliminary O&M budget
	Reviews Design Energy Budget	Establishes DESIGN ENERGY BUDGET	Reviews Design Energy Budget		Design Energy Budget
PM Reviews & accepts CONCEPTUAL DESIGN REPORT	Reviews Conceptual Design Report	Produces CONCEPTUAL DESIGN REPORT Submits to Project Manager Develops commissioning plan	Provides input re O&M items to Concept. Design Reviews Conceptual Design Report Co-ordinates and reviews commissioning plan		Conceptual Design Report Preliminary commissioning plan
<b>NPMS Project Delivery Stage - Implementation Phase - Working Documents</b>					
PM accepts working documents	Reviews DETAILED DESIGN at all stages of development	Develops WORKING DOCUMENTS including schematic, line diagrams, using new or generic Cx documentation, Identifies factory, on-site tests	Reviews detailed Design at all stages of develop't - from operational perspective as required Provides generic Cx documentation Reviews Cx specs		Working documents Cx specifications, PI and PV Report forms, Installation/Start-up Check Lists Cx specifications added to Construction specs

4th edition - November 2006

Copyright reserved

<b>Commissioning services - TRADITIONAL DESIGN CAPITAL CONSTRUCTION PROJECTS</b>					
<b>Project Leader (PL) Project Manager (PM) responsibilities</b>	<b>PWGSC Design quality review team responsibilities</b>	<b>Designer - (Consultant responsibilities</b>	<b>PWGSC QA Cx Manager responsibilities</b>	<b>Contractor responsibilities</b>	<b>Deliverables</b>
		Prepares Cx SPECS for subsystems, systems, integrated systems Develops <b>CHECK LISTS, PI &amp; PV REPORT FORMS</b>	Reviews Check Lists Reviews & accepts PI & PV forms		
	Reviews Design data on PI forms	Develops <b>TRAINING PLAN</b> Applies MMS to working documents Develops <b>BUILDING MANAGEMENT MANUAL</b> Adds <b>DESIGN DATA TO PI FORMS</b> <b>INTER - DISCIPLINARY COORDINATION</b>	Reviews & accepts Training Plan Reviews application of MMS to Working Doc'ts Reviews Building Management Manual Reviews design data on PI forms		<b>Training Plan</b>  <b>90% completed Building Management Manual</b>
PM accepts Commissioning Plan		Updates <b>COMMISSIONING PLAN</b>	Coordinates & reviews updated Commissioning Plan		<b>Updated Commissioning Plan</b>
		Prepares <b>DETAILED O&amp;M BUDGET</b>	Reviews & validates detailed O&M Budget		<b>Detailed O&amp;M Budget</b>
	Reviews updated Design Energy Budget	Updates <b>DESIGN ENERGY BUDGET</b>	Reviews updated Design Energy Budget		<b>Updated Design Energy Budget</b>
Reviews updated Commissioning Budget		Updates <b>COMMISSIONING BUDGET</b>	Reviews updated Commissioning Budget		<b>Updated Commissioning Budget</b>
		Studies <b>DE-Cx</b> req'ts of present facilities			
<b>NPMS Project Delivery Stage, Implementation Phase - Construction</b>					
PM accepts Commissioning Schedule		Reviews <b>COMMISSIONING SCHEDULE</b>	Reviews & recommends acceptance of comm'g sch	Develops Cx schedule Refines Cx Plan	<b>Commissioning Schedule</b>
	Reviews selected shop drawings for <b>MAJOR EQUIPMENT</b> for design	Reviews and accepts <b>SHOP DRAWINGS</b>	Reviews <b>selected shop drawings</b> for O&M	Submits <b>SHOP DRAWINGS</b>	<b>Accepted shop drawings</b>
		Reviews completed PI forms	Accepts completed PI forms	<b>Inputs data on to PI forms</b>	<b>Completed PI report forms</b>
	Witness <b>FACTORY TESTS</b> if required				

<b>Commissioning services - TRADITIONAL DESIGN CAPITAL CONSTRUCTION PROJECTS</b>					
<b>Project Leader (PL) Project Manager (PM) responsibilities</b>	<b>PWGSC Design quality review team responsibilities</b>	<b>Designer - (Consultant responsibilities</b>	<b>PWGSC QA Cx Manager responsibilities</b>	<b>Contractor responsibilities</b>	<b>Deliverables</b>
		Develops <b>INSTALLATION /START-UP CHECK LISTS</b>	Review Installation/ Start-up Check Lists	Verifies, utilizes Installation/ Start-up Check Lists	<b>Installation/Start-up Check lists</b>
	Reviews <b>TAB REPORTS</b> if required	Witnesses & verifies TAB. Reviews <b>TAB REPORTS</b> for acceptance	Reviews & validates <b>TAB REPORTS</b>	Conduct TAB. Prepare <b>TAB REPORTS</b>	<b>Approved TAB Reports</b>
<b>NPMS Project Delivery Stage, Implementation Phase - Commissioning</b>					
PM accepts completed <b>Building Management Manual</b>	Reviews completed <b>Building Management Manual</b>	<b>Completes OPERATING MANUAL ( part of BMM).</b> Completes <b>BUILDING. MANAGEMENT MANUAL</b>	Reviews, recommends acceptance of completed <b>BLDG MANAGEMENT MANUAL (BMM)</b>	Assemble <b>MAINTENANCE MANUAL</b> (part of BMM) Assists in completion of <b>OPERATING MANUAL</b>	<b>Completed Building Management Manual (BMM)</b>
PM accepts <b>Approved System &amp; Integrated system PV reports</b>	Participates in selected <b>SYSTEMS and INTEGRATED SYSTEMS</b> tests for performance verification	Monitors <b>COMMISSIONING ACTIVITIES</b> Certifies <b>SYSTEMS and INTEGRATED SYSTEMS TESTS.</b>	Witnesses selected systems & integrated systems tests & reviews test reports Monitors contract commissioning activities	Conducts component, equipment, subsystem, systems & integrated systems tests. Prepares <b>PV Reports</b> Coordinates all commissioning activities	<b>Approved System &amp; Integrated system PV reports</b>
		Provides <b>TRAINING</b> on design intent & on system design,	Coordinates participants for training, monitors training	Coordinates & implements Training	
<b>Conditional acceptance (if necessary</b>		Agrees to witness and certify <b>DEFERRED TESTS</b>	Approves <b>DEFERRED COMMISSIONING TESTS</b> due to seasonal or occupancy requirements	Identifies deferred comm'g tests due to seasonal or occupancy requirements	
<b>Conditional acceptance (if necessary</b>		Certifies rectification of <b>OUTSTANDING DEFICIENCIES</b>	verifies rectification of <b>OUTSTANDING DEFICIENCIES</b>	Addresses <b>OUTSTANDING DEFICIENCIES</b>	
		Assists in <b>RESOLVING ALL ISSUES RELATING TO COMMISSIONING</b>	Review all issues relating to commissioning	Address all issues relating to commissioning	
PM accepts and distributes <b>“As-Built” plans &amp; specifications</b>		Produces <b>“AS-BUILT” PLANS &amp; SPECIFICATIONS</b> from project records	Reviews & recommends acceptance of “As-Built” plans & specifications	Maintains accurate project records & assists in production of “As-Built”	° <b>“As-Built” plans &amp; specifications</b>
PM issues <b>CERTIFICATE</b>		Recommends to PM interim	Recommends <b>INTERIM</b>	Requests Issuance of	<b>Certificate of Interim</b>

<b>Commissioning services - TRADITIONAL DESIGN CAPITAL CONSTRUCTION PROJECTS</b>					
<b>Project Leader (PL) Project Manager (PM) responsibilities</b>	<b>PWGSC Design quality review team responsibilities</b>	<b>Designer - (Consultant responsibilities</b>	<b>PWGSC QA Cx Manager responsibilities</b>	<b>Contractor responsibilities</b>	<b>Deliverables</b>
<b>OF INTERIM ACCEPTANCE for occupancy</b>		acceptance	<b>ACCEPTANCE</b> to Designer	Interim Acceptance	<b>Acceptance</b>
<b>NOTE: Successful completion of commissioning (except for deferred commissioning, fine-tuning, trend logging and adjustment of ventilation rates to promote good IAQ is a requirement for issuance of the Interim Certificate</b>					
PM accepts and distributes <b>final commissioning documentation</b>		Provides <b>FINAL COMMISSIONING DOCUMENTATION</b>	Accepts & recommends use of final commissioning documentation	Assists in prep'n of final comm'g documentation	<b>Final Commissioning documentation</b>
PM issues <b>FINAL CERTIFICATE OF COMPLETION</b>		Signs off & recommends <b>FINAL ACCEPTANCE</b> to Project Manager	Recommend final acceptance to Designer		<b>Final Certificate of completion</b>
<b>NPMS Project Delivery Stage, Close Out Phase</b>					
	Assists as required	Assists in <b>FINE-TUNING</b> of systems & equip't as req'd.	Assists in fine-tuning as required	Fine-tunes systems & equipment as required	
PM accepts <b>DEFERRED COMMISSIONING TEST REPORTS</b>		<b>WITNESSES DEFERRED Cx TESTS.</b> Reviews and accepts test reports	Witnesses <b>deferred Cx</b> as required. Reviews & accepts <b>deferred Cx test reports</b>	Performs <b>deferred commissioning tests</b>	<b>Deferred commissioning test reports</b>
	Reviews report of <b>ENVIRONMENTAL &amp; SYSTEMS CHECKS</b>	Assists in <b>systems &amp; environmental checks</b>	Assists in <b>systems &amp; environmental check.</b> Reviews report.	Performs <b>systems &amp; environmental checks.</b> Prepares Report	<b>Systems &amp; Environmental Checks Report</b>
Initiates <b>POST- WARRANTY REVIEW</b>		Performs <b>POST- WARRANTY REVIEW</b>	Participates in <b>POST- WARRANTY REVIEW</b>	Addresses <b>WARRANTY ISSUES</b>	
PM reviews, accepts <b>FINAL COMMISSIONING REPORT</b>		Provides input into <b>FINAL COMMISSIONING REPORT</b>	Prepares <b>FINAL COMMISSIONING REPORT</b>	Provides input into <b>FINAL COMMISSIONING REPORT</b>	<b>Final Commissioning Report</b>
PM prepares <b>FINAL EVALUATION REPORT</b> for PL	Provides input to PM in prep'n of Final Evaluation Report	Assists PM in prep'n of Final Evaluation Report	Provides input to PM in prep'n of Final Evaluation Report	Provides input to PM in prep'n of Final Evaluation Report	<b>Final Evaluation Report</b>

**SYSTEMS FOUND TO BE UNCOMMISSIONABLE DUE TO DESIGN ERRORS AND/OR OMISSIONS  
SHALL BE REDESIGNED BY THE DESIGNER AND RE-COMMISSIONED AT HIS OWN EXPENSE**

### 1.13 Roles and responsibilities - Smaller design construction projects

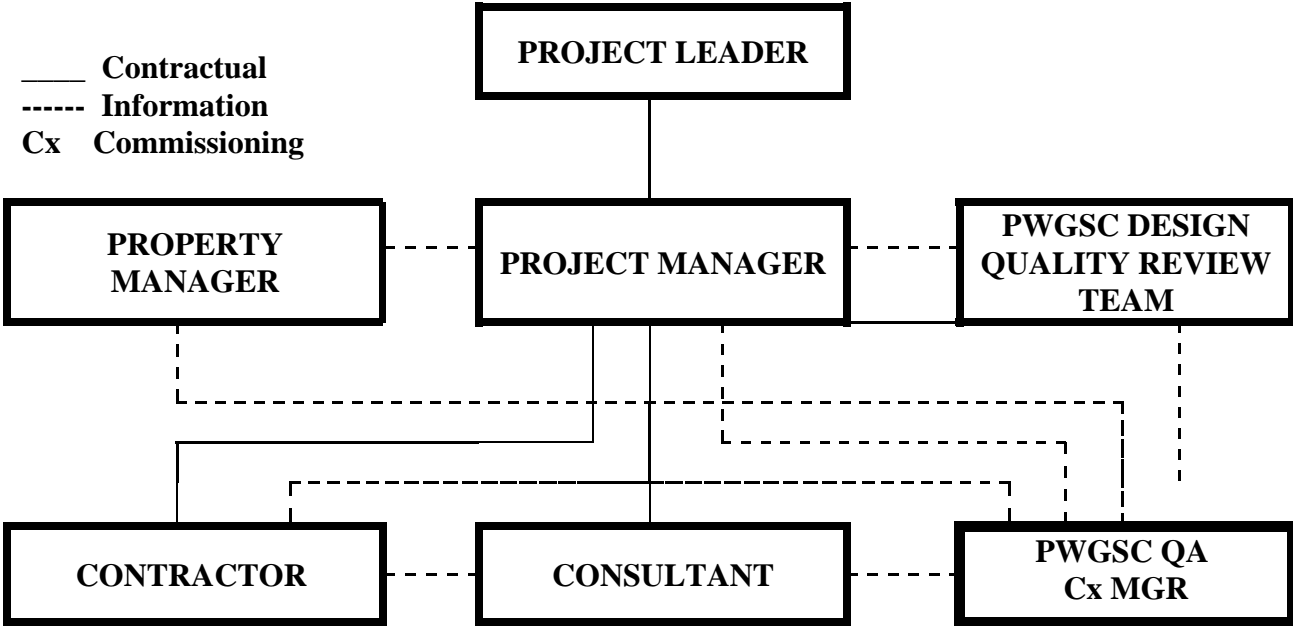

**Definition:**

**NOTE:** The above is an example ONLY. Stakeholders should refer to the project-specific communications and organization structure as established by the Project Manager.

**SMALLER DESIGN CONSTRUCTION PROJECTS** may be defined as projects for the installation of equipment, subsystems, systems and/or integrated systems having a limited scope and complexity. It also includes renovations and fit-ups

The scope of commissioning is identified by the stakeholders on a project-by-project basis..

**The Project Leader** is responsible for initiating the project on behalf of the Owner/Investor, for accepting the facility from the Project Manager and for handing it over to the Property Manager for operation. The Project Leader is also responsible to securing approved project funding.

**The Project Manager** has overall responsibility for managing the project after PDS Phase 1, and for demonstrating to the Client that the installed systems and overall facility meet the requirements defined in the Project Brief.

**PWGSC Design Quality Review Team:** reviews all aspects of design from development of the RFP to detailed design documents, agreement with proposed design solutions, quality assurance,



quality control, quality management, and the final evaluation including value for money and adherence to standards.

**PWGSC QA Commissioning Manager:** provides planning and technical advice on O&M matters, coordinates commissioning activities from project identification to close out phases, ensures O&M concerns are addressed, provides quality assurance and reviews commissioning documentation at all stages of project delivery including accuracy of Product Information (PI), Performance Verification (PV) and commissioning reports. Communications between the Commissioning Manager, the Designer and the Contractor is through the Project Manager. The Project Manager may delegate authority to the Commissioning Manager in matters relating to commissioning, while retaining overall responsibility for the project.

**Consultant (Designer):** refers to private sector consultant with its internal commissioning resources and to in-house designers. Develops Commissioning Plan, design intent and proposed design solutions, prepares commissioning specifications and other commissioning documentation, develop the Training Plan, witnesses and certifies performance of all commissioning activities, organizes and monitors all activities as per the Contract Agreement, and is responsible for its contractual design, construction, and warranty- related commitments. The appointment of a Commissioning Manager does not permit the Consultant (Designer) to abrogate traditional responsibilities (e.g. site supervision and ensuring that construction conforms to the design intent).

**Contractor/Commissioning Agent** carries out many start-up and performance verification activities, and carries out demonstrations and acceptance tests and related procedures. He acts as a coordinator only in matters relating to commissioning, refines the Commissioning Plan, develops the Commissioning Schedule, coordinates all commissioning activities in accordance with contract documents, including all tests for equipment, systems and integrated systems, and provides required documentation. The Contractor shall identify both the coordinator and the Commissioning Agent.

**The Property Manager** represents the Operator and is responsible for the day-to-day management and operation of the completed facility after it has been accepted from the Project Leader. During commissioning, he consults with the Project Manager on the acceptability of the facility, including training and documentation, before accepting the project for operation.

## SAMPLE 2

## Commissioning services - SMALLER DESIGN CONSTRUCTION PROJECTS

**Designer** may be either in-house Designer or private sector Consultant with his own commissioning resource person

**NOTE: All stakeholders must follow communications plan as established by the Project Manager**

Commissioning services - SMALLER DESIGN CONSTRUCTION PROJECTS					
Project Manager (PM) responsibilities	PWGSC DESIGN QUALITY REVIEW TEAM responsibilities	Designer - (Consultant) responsibilities	PWGSC QA Cx Manager responsibilities	Contractor responsibilities	Deliverables
<b>NPMS Project Identification Stage, Analysis Phase</b>					
PL identifies <b>COMMISSIONING BUDGET</b>			Provides input to <b>Commissioning Budget</b>		<b>Commissioning Budget</b>
<b>NPMS Project Delivery Stage, Planning Phase</b>					
PM develops <b>CX REQ'TS and SCOPE OF WORK</b>	Reviews <b>Cx REQ'TS and SCOPE OF WORK</b>		Develops <b>Cx REQ'TS and SCOPE OF WORK</b>		<b>Scope of Work Document or Terms of Reference</b>
<b>NPMS Project Delivery Stage, Design Phase</b>					
	Reviews <b>DESIGN CRITERIA, FUNCTIONAL REQ'TS</b>	Establishes <b>DESIGN CRITERIA, FUNCTIONAL &amp; OPERATIONAL REQ'TS</b>	Reviews <b>Design Criteria, operational requirements</b>		<b>Design Criteria Functional &amp; Operational requirements</b>
	Reviews <b>Design Energy Budget</b> if required	Establishes <b>DESIGN ENERGY BUDGET</b> if req'd	Reviews impact of Design energy budget on O&M if req'd		<b>Design Energy Budget</b> if required
Reviews & accepts <b>CONCEPTUAL DESIGN REPORT</b>	Reviews Conceptual Design Report	Produces <b>CONCEPTUAL DESIGN REPORT</b> Submits to Project Manager Develops commissioning plan	Provides input re O&M items. Reviews Conceptual Design Report Co-ordinates and reviews commissioning plan		<b>Conceptual Design Report Preliminary commissioning plan</b>
<b>NPMS Project Delivery Stage, Implementation Phase -Working Documents</b>					
PM accepts working documents	Reviews <b>DETAILED DESIGN</b> at all stages of development	Develops <b>WORKING DOCUMENTS</b> for sub-systems, systems, integrated systems	Reviews working documents at all stages of design from operational & mtce perspective		<b>Working documents</b>

<b>Commissioning services - SMALLER DESIGN CONSTRUCTION PROJECTS</b>					
<b>Project Manager (PM) responsibilities</b>	<b>PWGSC DESIGN QUALITY REVIEW TEAM responsibilities</b>	<b>Designer - (Consultant) responsibilities</b>	<b>PWGSC QA Cx Manager responsibilities</b>	<b>Contractor responsibilities</b>	<b>Deliverables</b>
PM accepts <b>Commissioning Plan</b>		Develops <b>PI &amp; PV REPORT FORMS</b>	Reviews, accepts PI & PV Forms		<b>PI and PV Report forms</b>
		Develops <b>TRAINING PLAN</b>	Reviews training plans		<b>Training Plan</b>
		Updates <b>COMMISSIONING PLAN</b>	Coordinates & reviews updated commissioning plan		<b>Updated Commissioning Plan</b>
		<b>INTER- DISCIPLINARY COORDINATION</b>			
		Updates <b>BUILDING MANAGEMENT MANUAL</b>	Reviews Building Management Manual		<b>Updated Building Management Manual</b>
		Prepares <b>O&amp;M BUDGET</b>	Validates impact of O&M Budget		<b>O&amp;M Budget</b>
<b>NPMS Project Delivery Stage, Implementation Phase - Construction</b>					
PM accepts <b>Commissioning Schedule</b>	Reviews shop drawings for selected major equipment for design Witnesses <b>FACTORY TESTS if required</b>	Reviews <b>COMMISSIONING SCHEDULE</b>	Reviews Cx schedule	Develops Cx Schedule. Refines Cx Plan  Submits shop drawings. Inputs data on to PI forms	<b>Commissioning Schedule</b>  <b>Accepted shop drawings</b> <b>Completed PI forms</b>
		Reviews and accepts <b>SHOP DRAWINGS</b>	Reviews selected shop drawings from O&M perspective		
	Reviews <b>TAB REPORTS</b> if required	Witnesses & verifies <b>TAB</b> Reviews & accepts <b>TAB reports</b>	Reviews & validates <b>TAB reports</b>	Conducts <b>TAB</b> Prepares <b>TAB reports</b>	<b>Approved TAB Reports</b>
<b>NPMS Project Delivery Stage, Implementation Phase - Commissioning</b>					
PM accepts <b>PV Reports</b>	Reviews <b>PV REPORTS</b> Participate in <b>selected system &amp; integrated system tests</b> for PV	Verifies & accepts <b>SYSTEMS and INTEGRATED SYSTEMS TESTS</b> Reviews <b>PV Reports</b>	Reviews and verifies PV Reports	Conducts component, equipment, subsystem, system and integrated system tests and performance verification. Prepares <b>PV REPORTS</b>	<b>Approved PV Reports</b>
PM accepts completed <b>O&amp;M Manual</b>		Reviews <b>COMPLETED OPERATING &amp; MAINTENANCE MANUAL</b>	Reviews Operating & Maintenance Manual	Completes assembly of Operating & Maintenance Manual	<b>Approved Operating &amp; Maintenance Manual</b>

<b>Commissioning services - SMALLER DESIGN CONSTRUCTION PROJECTS</b>					
<b>Project Manager (PM) responsibilities</b>	<b>PWGSC DESIGN QUALITY REVIEW TEAM responsibilities</b>	<b>Designer - (Consultant) responsibilities</b>	<b>PWGSC QA Cx Manager responsibilities</b>	<b>Contractor responsibilities</b>	<b>Deliverables</b>
PM accepts <b>Systems and Integrated systems PV reports</b>		Witnesses <b>SYSTEMS &amp; INTEGRATED SYSTEMS TESTS</b> , reviews & accepts test reports  Monitors <b>COMMISSIONING ACTIVITIES</b>	Witnesses selected systems & integrated systems tests & reviews test reports  Monitors comm'g activities	Conducts systems & integrated systems tests  Coordinates all commissioning activities	<b>Approved System &amp; Integrated system test reports</b>
		Provides <b>TRAINING</b> on design intent & on system design,	Coordinates participants monitors training	Coordinates & implements Training	
PM accepts and distributes <b>“AS-BUILT” PLANS &amp; SPECS</b>		Produces <b>“AS-BUILT” PLANS &amp; SPECS</b> from project records	Reviews “As-Built” records	Maintains accurate project records & assists in production of “As-Built”	° <b>“As-Built” plans &amp; specs</b>
	Assists in fine-tuning as required	Assists in <b>FINE-TUNING</b> of systems & equip't as req'd.	Assists in fine-tuning as required	Fine-tunes systems & equipment as required	
		Identifies <b>DEFICIENCIES</b>	Verifies rectification of deficiencies	Rectifies all deficiencies	
PM Produces <b>CERTIFICATE OF INTERIM ACCEPTANCE FOR OCCUPANCY</b>		Recommends to PM interim acceptance	Signs-off systems and recommends interim acceptance to Designer	Requests issuance of Interim Acceptance	<b>Certificate of Interim Acceptance</b>
<b>NOTE: Successful completion of commissioning (except for deferred commissioning, fine-tuning, trend logging and adjustment of ventilation rates to promote good IAQ is a requirement for issuance of the Interim Certificate</b>					
PM accepts and distributes <b>“As-Built” plans &amp; specifications</b>		Produces <b>“AS-BUILT” PLANS &amp; SPECIFICATIONS</b> from project records	Reviews & recommends acceptance of “As-Built” plans & specifications	Maintains accurate project records & assists in production of “As-Built”	° <b>“As-Built” plans &amp; specifications</b>
PM issues <b>FINAL CERTIFICATE</b>		Signs off & recommends final acceptance to Project Manager	Signs off, recommends final acceptance to PM		<b>Final Certificate of completion</b>
<b>NPMS Project Delivery Stage, Close Out Phase</b>					
		Address <b>WARRANTY ISSUES</b>	Comments on warranty issues	Addresses warranty issues	

<b>Commissioning services - SMALLER DESIGN CONSTRUCTION PROJECTS</b>					
<b>Project Manager (PM) responsibilities</b>	<b>PWGSC DESIGN QUALITY REVIEW TEAM responsibilities</b>	<b>Designer - (Consultant) responsibilities</b>	<b>PWGSC QA Cx Manager responsibilities</b>	<b>Contractor responsibilities</b>	<b>Deliverables</b>
PM reviews, accepts <b>FINAL COMMISSIONING REPORT</b>		Provides input into <b>FINAL COMMISSIONING REPORT</b>	Prepares <b>FINAL COMMISSIONING REPORT</b>	Provides input into <b>FINAL COMMISSIONING REPORT</b>	<b>Final Commissioning Report</b>
PM prepares <b>EVALUATION REPORT</b> for PL	Provides input to PM in preparation of <b>EVALUATION REPORT</b>	Assists PM in preparation of <b>EVALUATION REPORT</b>	Provides input to PM in prep'n of <b>EVALUATION REPORT</b>	Provides input to PM in prep'n of <b>EVALUATION REPORT</b>	<b>Evaluation Report</b>

**SYSTEMS FOUND TO BE UNCOMMISSIONABLE DUE TO DESIGN ERRORS AND/OR OMISSIONS SHALL BE REDESIGNED BY THE DESIGNER AND RE-COMMISSIONED AT HIS OWN EXPENSE**

### 1.14 Roles and responsibilities - Design-build projects

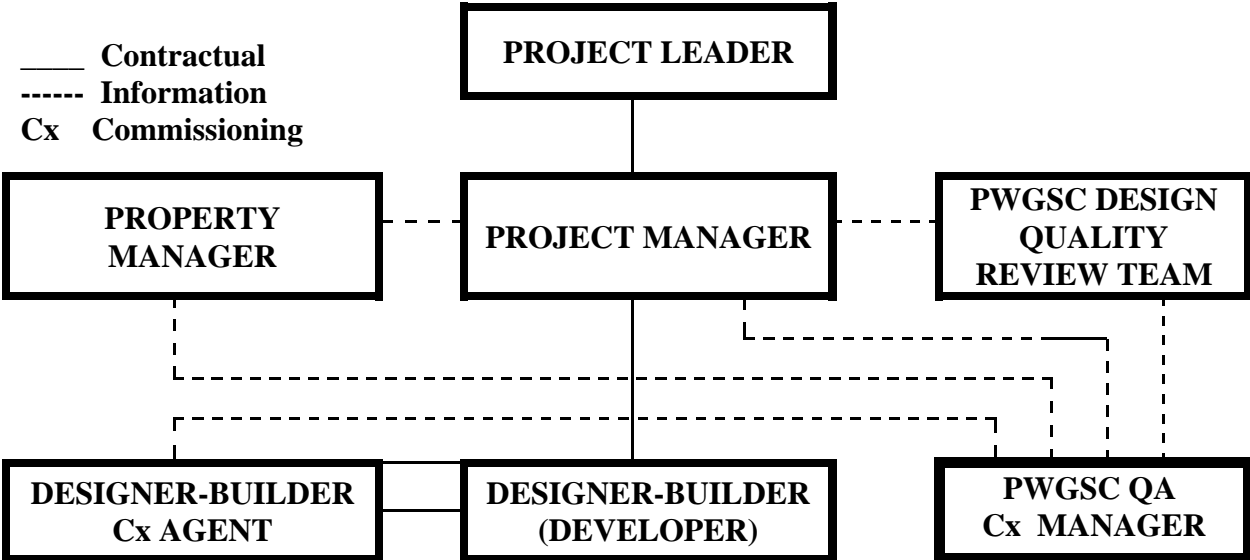

**NOTE:** The above is an example ONLY. Stakeholders should refer to the project-specific communications and organization structure as established by the Project Manager.

**The Project Leader** is responsible for initiating the project on behalf of the Owner/Investor, for accepting the project from the Project Manager and for handing it over to the Property Manager for operation. The Project Leader is also responsible for securing approved project funding.

**The Project Manager** has overall responsibility for managing the project , and for demonstrating to the Project Leader that the installed systems and overall facility meet the requirements defined in the Project Brief.

**PWGSC Design Quality Review Team:** reviews all aspects of design from development of the RFP to Conceptual Design Report, agreement with proposed design solutions, quality assurance, quality control, quality management, detailed design, working documents, and the final evaluation including value for money and adherence to standards.

**PWGSC QA Commissioning Manager:** provides planning and technical advice on O&M matters, coordinates commissioning activities from project identification to close out phase, ensures O&M concerns are addressed, provides quality assurance and reviews commissioning documentation at all stages of project delivery including accuracy of PV and commissioning reports. Communications between the Commissioning Manager, the Designer and the Contractor is through the Project Manager. The Project Manager may delegate authority to the Commissioning Manager in matters relating to commissioning, while retaining overall responsibility for the project.

**Designer-Builder (Developer):** is responsible to develop design solutions meeting the requirements of the Client, prepare commissioning specifications and other commissioning

documentation and to develop the Training Plan. As the Builder: is responsible for the construction / installation of the project and for all commissioning activities including witnessing of performance testing.

**Design-Builder's Commissioning Agent:** is responsible to fulfill the commissioning program, prepare and submit a Commissioning Plan, develop Commissioning Schedules, for detailed coordination of commissioning activities, executing all commissioning activities in accordance with the contract documents, providing direction for all matter relating to commissioning including tests of systems, integrated systems and equipment and providing all required documentation.. The Design-Builder's Commissioning Agent acts as a coordinator in all matters relating to commissioning. He coordinates all commissioning activities, making sure that commissioning activities are implemented in accordance with the Commissioning Schedule. On major projects, the Contractor shall identify both the coordinator and the Commissioning Agent.

**The Property Manager** represents the Operator and is responsible for the day-to-day management and operation of the completed facility after it has been accepted from the Project Leader. During commissioning, he consults with the Project Manager on the acceptability of the facility, including training and documentation, before accepting the project for operation.

**SAMPLE 3****Commissioning services - DESIGN-BUILD PROJECTS**

**Designer** may be either in-house Designer or private sector Consultant with his own commissioning resource person

**NOTE: All stakeholders must follow communications plan as established by the Project Manager**

<b>Commissioning services - DESIGN-BUILD PROJECTS</b>					
<b>Project Leader (PL) Project Manager (PM) responsibilities</b>	<b>PWGSC DESIGN QUALITY REVIEW TEAM responsibilities</b>	<b>Designer - Builder (Developer) responsibilities</b>	<b>PWGSC QA Commissioning Manager responsibilities</b>	<b>Design-Builder / Design- Builder's Commissioning Agent responsibilities</b>	<b>Deliverables</b>
<b>NPMS Project Identification Stage, Analysis Phase</b>					
Project Leader prepares IAR					IAR
PL identifies & BUDGETS for COMMISSIONING in IAR			Provides input to Commissioning Budget		Commissioning budget
<b>NPMS Project Delivery Stage, Planning Phase</b>					
Project Mgr. develops RFP including commissioning	Provides design input into RFP		Provides commissioning input into RFP		Request for Proposal (RFP)
PM develops DESIGN-BUILD SPECS Incorporates into RFP	Provides design input into DESIGN-BUILD SPECS		Reviews design input into DESIGN-BUILD SPECIFICATIONS Reviews Comm'g specs & documentation to suit RFP		Design-Build specifications
<b>NPMS Project Delivery Stage, Design Phase</b>					
	Reviews DESIGN CRITERIA and FUNCTIONAL REQ'TS	Reconfirms Design Criteria, functional & Operational requirements from RFP	Reviews & coordinates OPERATIONAL & MTCE REQ'TS		Design Criteria, Functional & Operational req'ts
		Establishes O&M BUDGET	Reviews O&M budget		O&M budget
	Reviews Design Energy Budget	Establishes DESIGN ENERGY BUDGET	Review impact of Design Energy Budget on O&M		Design Energy Budget
Reviews & accepts CONCEPTUAL DESIGN REPORT	Reviews Conceptual Design Report	Produces CONCEPTUAL DESIGN REPORT Submits to Project Manager Develops commissioning plan	Reviews Conceptual Design Report for O&M issues. Co-ordinates and reviews commissioning plan		Conceptual Design Report Preliminary Commissioning Plan
<b>NPMS Project Delivery Stage, Implementation Phase - Working Documents</b>					
PM accepts working documents	Reviews DESIGN DEVELOPMENT at	Develops WORKING DOCUMENTS including schematics, line diagrams,	Reviews DESIGN DEVELOPMENT at all		Working documents



<b>Commissioning services - DESIGN-BUILD PROJECTS</b>					
<b>Project Leader (PL) Project Manager (PM) responsibilities</b>	<b>PWGSC DESIGN QUALITY REVIEW TEAM responsibilities</b>	<b>Designer - Builder (Developer) responsibilities</b>	<b>PWGSC QA Commissioning Manager responsibilities</b>	<b>Design-Builder / Design- Builder's Commissioning Agent responsibilities</b>	<b>Deliverables</b>
	all stages of development from functional perspective		stages from operational & Mtce. perspectives		
		Prepares <b>Cx SPECS</b> for subsystem, system, integrated system	Review commissioning specifications		<b>Commissioning specifications</b>
		Develops <b>PI &amp; PV Report Forms and Check Lists</b>	Reviews <b>PI &amp; PV Report Forms</b>		<b>PI &amp; PV Report Form and Check Lists</b>
PM accepts <b>Commissioning Plan</b>		Updates <b>COMMISSIONING PLAN</b>	Coordinates & Reviews updated <b>Commissioning Plan</b>		<b>Updated Commissioning Plan</b>
		Prepares <b>TRAINING PLAN</b>	Reviews and accepts <b>Training Plan</b>		<b>Training Plan</b>
	Provides input to <b>Building Management Manual</b>	Develops <b>BUILDING MANAGEMENT MAN'L</b>	Coordinates & Reviews <b>Bldg Manage't Manual</b>		<b>Building Management Manual</b>
		<b>INTER-DISCIPLINARY COORDINATION</b>			
		Prepares <b>DETAILED O&amp;M BUDGET</b>	Validates impact of detailed O&M Budget		<b>Detailed O&amp;M Budget</b>
	Reviews updated Design Energy Budget	Updates <b>DESIGN ENERGY BUDGET</b>	Reviews impact of Design Energy Budget on O&M		<b>Updated Design Energy Budget</b>
Reviews updated Commissioning Budget		Updates <b>Cx BUDGET</b>	Reviews updated Commissioning Budget		<b>Updated Commissioning Budget</b>
<b>NPMS Project Delivery Stage, Implementation Phase - Construction</b>					
PM accepts <b>Commissioning Schedule</b>	Reviews shop drgs for <b>MAJOR EQUIP'T</b> for design Witnesses <b>FACTORY TESTS</b> as required	Reviews <b>Cx SCHEDULE</b>  Reviews and accepts <b>SHOP DRAWINGS</b>  Reviews completed <b>PI forms</b> Develops <b>INSTALLATION /START-UP CHECK LISTS</b>	Reviews commissioning schedule Reviews selected shop drawings for O&M  Witnesses <b>FACTORY TESTS</b> as req'd. Submits report to Project Mgr. Accepts completed <b>PI forms</b> Reviews & accepts <b>Check Lists</b>	Develops Cx schedule. Refines Cx Plan. Submits shop drawings  Inputs data on to <b>PI forms</b>  Utilizes <b>Installation/ Start-up Check Lists</b>	<b>Commissioning Schedule</b>  <b>Approved shop drawings</b>  <b>Completed PI Forms</b>  <b>Installation/Start-up Check Lists</b>
	Reviews <b>TAB REPORTS</b> if required	Witnesses & verifies TAB.	Reviews & verifies TAB reports	Conduct <b>TAB</b> Prepare <b>TAB REPORTS</b>	<b>Approved TAB Reports</b>

<b>Commissioning services - DESIGN-BUILD PROJECTS</b>					
<b>Project Leader (PL) Project Manager (PM) responsibilities</b>	<b>PWGSC DESIGN QUALITY REVIEW TEAM responsibilities</b>	<b>Designer - Builder (Developer) responsibilities</b>	<b>PWGSC QA Commissioning Manager responsibilities</b>	<b>Design-Builder / Design- Builder's Commissioning Agent responsibilities</b>	<b>Deliverables</b>
		Reviews TAB reports for acceptance			
<b>NPMS Project Delivery Stage, Implementation Phase - Commissioning</b>					
PM accepts <b>approved System PV Reports</b>	Witnesses <b>FACTORY TESTS</b> as required  Reviews <b>PV REPORTS</b> if required	Monitors <b>all Cx ACTIVITIES</b>  Verify & approve <b>SYSTEMS TESTS</b>  Reviews, accepts <b>PV reports</b>	Monitors contract commissioning activities  Witnesses selected systems tests  Reviews test PV Reports	Coordinates all commissioning activities Conducts component, equip't subsystem & system <b>START-UP, PERFORMANCE VERIFICATION</b>  Prepares <b>PV REPORTS</b>	<b>Completed PV reports</b>
	Reviews <b>COMPLETED BLDG MANAGEMENT MANUAL</b>	<b>Reviews completed BUILDING MANAGE'T MANUAL (BMM)</b>	Reviews completed Building Management Manual	Assists in completion of Building Management Manual	<b>Completed Building Management Manual</b>
PM accepts <b>approved integrated system PV Reports</b>		Witnesses <b>INTEGRATED SYSTEMS TESTS</b> Reviews & accepts test reports	Witnesses selected integrated systems tests & reviews test reports	Conducts integrated systems tests	<b>Approved System &amp; Integrated system test reports</b>
		Provides <b>TRAINING</b> on design intent & on system design.	Coordinates participants for training, monitors training	Coordinates & implements Training	
		Compiles list of <b>deferred commissioning tests</b>	Approves <b>DEFERRED COMMISSIONING TESTS</b> due to seasonal or occupancy	Identifies deferred comm'g tests due to seasonal or occupancy requirements	
		Assists in <b>RESOLVING ALL ISSUES RELATING TO COMMISSIONING</b>	Reviews all issues relating to commissioning	Addresses all issues relating to commissioning	
		Identifies <b>DEFICIENCIES</b>	Verifies rectification of deficiencies	Rectifies all deficiencies	
Conditional acceptance of deferred commissioning (if necessary)		Agrees to review <b>DEFERRED Cx</b>	Reviews results of <b>DEFERRED Cx</b>	Agrees to perform <b>DEFERRED Cx</b>	
Conditional acceptance of O/S deficiencies (if necessary)		Agrees to verify <b>OUTSTANDING DEFICIENCIES</b>	Verifies completion of <b>OUTSTANDING DEFICIENCIES</b>	Agrees to rectify <b>OUTSTANDING DEFICIENCIES</b>	

<b>Commissioning services - DESIGN-BUILD PROJECTS</b>					
<b>Project Leader (PL) Project Manager (PM) responsibilities</b>	<b>PWGSC DESIGN QUALITY REVIEW TEAM responsibilities</b>	<b>Designer - Builder (Developer) responsibilities</b>	<b>PWGSC QA Commissioning Manager responsibilities</b>	<b>Design-Builder / Design- Builder's Commissioning Agent responsibilities</b>	<b>Deliverables</b>
PM issues <b>CERTIFICATE OF INTERIM ACCEPTANCE</b> for occupancy		Requests interim acceptance	Recommends sign-off of systems		<b>Certificate of Interim Acceptance</b>
<b>NOTE: Successful completion of commissioning (except for deferred commissioning, fine-tuning, trend logging and adjustment of ventilation rates to promote good IAQ is a requirement for issuance of the Interim Certificate</b>					
PM accepts & distributes <b>FINAL COMMISSIONING DOCUMENTATION</b>	Reviews final <b>commissioning documentation</b>	Provides <b>FINAL COMMISSIONING DOCUMENTATION</b>	Accepts final commissioning documentation	Assists in prep'n of final Cx documentation	<b>Final Commissioning documentation</b>
PM issues <b>FINAL CERTIFICATE OF COMPLETION</b>		Signs off & recommends final acceptance to Project Manager	Signs off & recommends final acceptance to Designer-Builder		<b>Final Certificate of completion</b>
<b>NPMS Project Delivery Stage, Close Out Phase -</b>					
	Assists as required	Assists in <b>FINE-TUNING</b> of systems & equip't as req'd.	Assists in fine-tuning as required	Fine-tunes systems & equipment as required	
PM accepts <b>DEFERRED COMMISSIONING TEST REPORTS</b>		Witnesses <b>DEFERRED COMM'G TESTS</b> . Reviews and accepts test reports	Witnesses <b>DEFERRED COMMISSIONING</b> as required. Reviews test reports	Performs <b>DEFERRED COMMISSIONING TESTS</b>	<b>Deferred Commissioning reports</b>
		Assists in <b>RESOLVING ALL ISSUES RELATING TO Cx</b>	Review all issues relating to commissioning	Address all issues relating to commissioning	
	Reviews report of <b>ENVIRONMENTAL &amp; SYSTEMS CHECKS</b>	Assists in <b>systems &amp; environmental checks</b> . Reviews & accepts reports	Assists in <b>systems &amp; environmental check</b> . Reviews report.	Performs <b>systems &amp; environmental checks</b> . Prepares Report	<b>Systems &amp; Environmental Checks Report</b>
		Identifies <b>DEFICIENCIES</b>	Verifies rectification of deficiencies	Rectifies all deficiencies Addresses <b>WARRANTY ISSUES</b>	
Initiates <b>POST WARRANTY REVIEW</b>		Performs <b>POST WARRANTY REVIEW</b>	Participates in <b>POST WARRANTY REVIEW</b>		
PM reviews and accepts <b>FINAL COMMISSIONING REPORT</b>		Provides input into <b>FINAL COMMISSIONING REPORT</b>	Develops <b>FINAL COMMISSIONING REPORT</b>	Provides input into <b>FINAL COMMISSIONING REPORT</b>	<b>Final Commissioning Report</b>

<b>Commissioning services - DESIGN-BUILD PROJECTS</b>					
<b>Project Leader (PL) Project Manager (PM) responsibilities</b>	<b>PWGSC DESIGN QUALITY REVIEW TEAM responsibilities</b>	<b>Designer - Builder (Developer) responsibilities</b>	<b>PWGSC QA Commissioning Manager responsibilities</b>	<b>Design-Builder / Design- Builder's Commissioning Agent responsibilities</b>	<b>Deliverables</b>
PM prepares <b>EVALUATION REPORT</b> for PL.	Provides input to PM in preparation of <b>EVALUATION REPORT</b>	Assists PM in preparation of <b>EVALUATION REPORT</b>	Provides input to PM in prep. of <b>EVALUATION REPORT</b>	Provides input to PM in preparation of <b>EVALUATION REPORT</b>	<b>Evaluation Report</b>

**SYSTEMS FOUND TO BE UNCOMMISSIONABLE DUE TO DESIGN ERRORS AND/OR OMISSIONS SHALL BE REDESIGNED BY THE DESIGNER AND RE-COMMISSIONED AT HIS OWN EXPENSE**

## **1.15 Roles & responsibilities - AFD managed facilities - Projects over \$200K**

### **.1 General**

The contractual and information movement organizational chart and all information regarding the participants to commissioning shall be in full accordance with the *"AFD Management Handbook - Standard Operating Procedures for Commissioning Projects over \$200K in AFD Managed Buildings"* - latest edition.

### **.2 Commissioning services**

Commissioning Services for projects in AFD - Managed facilities shall be in accordance with Table 1 forming part of the *"AFD Management Handbook - Standard Operating Procedures for Commissioning Projects over \$200K in AFD Managed Buildings"* (latest edition).

## Chapter 2 Commissioning documentation

### 2.1 Introduction

Commissioning documentation is a complete set of data and information fully describing the completed project as a built, finished, functional and operational facility presented in a form in which it can be operationally-occupied, maintained, updated and used over the life of the building. The transfer of a completed facility to the Project Leader must include appropriate documentation on how the facility is designed and constructed, and how to operate, maintain, repair, clean, manage and modify it.

A comprehensive set of system documents serves as a common database for all project team members from all disciplines. Quality documentation of all components, systems and environments as commissioned is also essential for use in the training of O&M personnel and for the operation, maintenance, servicing and repair of all systems, components and equipment in the facility. It serves as a project archive for future reference base data for operations and maintenance, renovations and inspection purposes. It can provide a valuable record of experience for feedback to other projects.

Commissioning documentation maintain a paper trail of design decisions, trade-offs, etc., made during the entire project, commencing at the NPMS project identification stage, analysis phase provides:

- .1 a record of user requirements for use by the Design Team,
- .2 a description of the Design Intent and limitations of various systems,
- .3 design decisions, design assumptions, trade-offs necessary to arrive at the approved design solution,
- .4 a complete record of each system and building component,
- .5 changes made to the design prior to hand-over and acceptance,
- .6 a documented measure of quality control throughout the progress of the project,
- .7 a record of performance levels and acceptance tests,
- .8 information on how to operate the building,
- .9 estimated costs for operating the building,
- .10 heritage character statement and conservation guidelines (for heritage buildings).

### 2.2 Project archives

An archival operation needs to be defined and set up by the Commissioning Manager in conjunction with the Project Manager in the project delivery stage, planning phase. The Project Archives should include all commissioning documents that contain data deemed essential to a comprehensive record of the project and its component systems. The purpose is to provide:

- .1 a complete historical record of the project
- .2 procedures and performance levels for re-commissioning

- .3 documentation control
- .4 feedback mechanism for knowledge transfer

Provision shall be made for the controlled storage of all commissioning documentation within the project archive.

### **2.3 Commissioning documentation package**

The intent is to maintain a paper trail of design decisions, trade-offs, etc., made during the entire project, commencing at the project identification stage, analysis phase. It should include:

- 1. design decisions, design assumptions, trade-offs necessary to arrive at the approved design solution,
- .2 changes made to the design prior to hand-over and acceptance.

The whole package of commissioning documentation comprises the following documents, each of which is described in detail in subsequent paragraphs of this chapter:

- .1 The Investment Analysis Report
- .2 The Request for Proposal containing the Commissioning Brief
- .3 Design Criteria and Design Intents
- .4 Working Documents revised to show all work as actually constructed and installed
- .5 Building Management Manual (BMM) for the complete building. BMM for heritage buildings require additional information on how to maintain (standards, methods, materials, skills) and a technical maintenance manual for the property.
- .6 Training documentation
- .7 Commissioning Reports, produced at the end of the project delivery stage, implementation phase and close out phase.
- .8 Final Commissioning Report

### **2.4 Investment Analysis Report (IAR)**

This is the document from which the Request for Proposal (RFP) or the Project Brief is developed.

### **2.5 Request For Proposal (RFP)**

This is the outcome of the IAR . It must include sections describing:

- .1 the Client's FUNCTIONAL and OPERATIONAL requirements - see item 2.6, below,
- .2 O&M requirements,
- .3 commissioning requirements in the form of a Commissioning Brief. See item 2.8, below.

## 2.6 Functional requirements and operational requirements

These form the very foundation of the entire design. If these are given the very serious consideration that they deserve from the outset, there is every possibility that the entire project will be effectively commissioned and client satisfaction is assured. Functional requirements and operational requirements must not be open to any misinterpretation or misunderstanding. If these are not established by the client they may be established by the Project Manager or the designer.

### **FUNCTIONAL REQUIREMENTS** include:

1. design criteria, design intents, design assumptions, design issues, design solutions,
2. issues of health, welfare, comfort and safety of the occupants and operating personnel,
3. indoor environmental space requirements, IAQ, acoustical privacy, physical security,
4. and other special requirements of the user. These could include client's specific requirements for systems' commissioning.

### **OPERATIONAL REQUIREMENTS** include:

1. spatial requirements for O&M personnel,
2. cost-effective O&M,
3. provisions for re-commissioning, adjustment and fine-tuning of the facility during its entire life,
4. provisions for complete documentation, including ease of addressibility, storage facilities,
5. training of O&M personnel (and user),
6. Life Safety Systems.

## 2.7 Design criteria

Design Criteria are identified in the RFP or Project Brief and may be established by the Client, or by various codes, standards and regulations (enforced by an authorities having jurisdiction, to be identified). These may include, but are not necessarily limited to:

- .1 conservation guidelines, heritage character statements,
- .2 various PWGSC standards,
- .3 environmental standards including ASHRAE Standards 90.1, 62, and 55.
- .4 Security and access requirements as established by the Authority Having Jurisdiction,
- .5 Accessibility standards.
- .6 Operational characteristics such as:
  - .a Spatial requirements for O&M facilities and services,



- .b O&M and life cycle costs, reliability, durability, operability, maintainability, accessibility, serviceability
- .7 Partial and phased occupancy,
- .8 Disruption of normal environmental conditions,
- .9 Life support systems, security, access, power, vertical transportation, etc., for present occupants (this would apply particularly to renovation projects),
- .10 Hours of occupancy - normal, and extended.

For existing buildings, design criteria should be based upon considerations such as age and condition of the building, architectural and structural considerations, exterior environmental conditions, previous usage, etc.

Design criteria must include:

- .1 **design tolerances** (eg. design margins, safety factors, standby and redundancy, etc.)
- .2 **application tolerance** for each system which must be realistic and attainable. Both of these items must be the result of careful examination of the functional and operational requirements contained in the RFP.

If design criteria are not established by the client, they may be established by the Project Manager in the RFP. In this case, they must be approved by the PWGSC Design Quality Review Team during the development of the Conceptual Design Report. They must be based upon considerations such as building age, heritage value, architectural and structural considerations, condition, of the existing building, exterior environmental conditions, previous usage, etc.

**Design criteria for Design-build projects:** These are especially important because of the limited involvement and opportunity for defining project requirements by A&ES and Property and Facilities Management (PFM) during the project identification stage, planning phase. It is therefore critical that, without limiting the freedom of the designer-builder to develop innovative design solutions, that all the appropriate design criteria, performance criteria, etc., be clearly established in the RFP. All commissioning roles and commissioning activities must be clearly defined within the design-build Request For Proposal (RFP).

## 2.8 Commissioning Brief

This is the section of the Project Brief in which commissioning requirements are clearly defined. The Commissioning Brief identifies the Owner's/Investor's/ Client's expectations – what needs to be done together with estimated costs for commissioning; the Commissioning Plan identifies the systems and delineates the procedures and schedules.

The Commissioning Brief defines the deliverables from an O&M perspective and describes the scope of commissioning and associated budget (normally established in the IAR).

## **2.9 Conceptual Design Report**

The Conceptual Design Report contains the designer's proposed solutions to the requirements contained in the RFP and must include all design intents (i.e. the methodology by which the designer proposes to meet the design criteria).

The designer must be very careful and judicious in the practice of adding "safety factors" to design calculations. Unless strictly controlled, these accumulated factors will often lead to over-sizing of equipment and systems, resulting in difficulties in commissioning.

The Conceptual Design Report for mechanical systems must include decisions relating to the introduction of good quality outside air in well-controlled and measurable quantities into HVAC systems in order to maintain satisfactory IAQ at all times. Unless considered at the outset of the project this may well be forgotten, or squeezed out for want of the small amount of additional space in the Mechanical Equipment Room.

The Conceptual Design Report for heritage buildings must include the documents which define the heritage character of the property and a description of the conservation approach which outlines how this will be balanced with functional goals.

## **2.10 Detailed design development**

This must include very careful attention to details including:

- .1 what system and equipment must be connected to emergency power.
- .2 the impacts of standby capacity and redundancy.
- .3 careful and appropriate selection of construction materials, installation practices and performance verification procedures, etc. WHMIS data sheets for all materials to be incorporated into the project must be carefully examined at this stage of the project's development.
- .4 Specifications must reflect this concern for quality assurance in design. They must be complete, and include requirements for commissioning.

Increasing complexity of control systems requires that DDC, EMCS and BAS systems, fire alarm systems and life safety systems receive special consideration when preparing specifications.

The insistence on quality assurance in design must flow into the insistence on quality control during construction. All parties to a construction project take much great care in all aspects of project management. Once design solutions have been established, and system selection with its associated equipment selection have been accepted, it is very often difficult, if not impossible to change to a design that will more readily comply with the requirement to minimize O&M costs.

## 2.11 Working documents

The working documents consist of the plans and specifications developed by the designer to describe the built works. They set out the quality control and quality assurance for the project. Plans and specifications are used by the Project Commissioning Team to verify that the built works conform to all commissioning deliverables.

## 2.12 Commissioning specifications

Although these form an integral part of the working documents, they are listed separately because of their importance in commissioning the built works. They must include sufficient details to enable the contractor to understand all requirements clearly and to submit an accurate price for commissioning and must include:

1. The Commissioning Plan which has been agreed with the PWGSC Commissioning Manager. For detailed description, refer to *CP.3: "Guide to Development of the Commissioning Plan"*.
2. All required performance verification procedures if not already covered in the Commissioning Procedures Manual of the discipline involved.
3. The Building Management Manual: to include all design intent and design criteria, objectives of commissioning and manner of operation of all systems, equipment and components, desired results and functions to be performed.
4. All requirements for preparation of the Maintenance Manual, including maintenance materials, spare parts, special tools, together with instructions for identification, inventory, storage and instructions for use.
5. A list of all factory and on-site performance tests; all to be witnessed and certified.
6. List of activities to be performed by the contractor as part of the Add-on Contract during the Warranty Period.
7. All conditions under which installed equipment may be temporarily operated by the Contractor and all refurbishing requirements.
8. Training requirements.
9. Requirements for preparation of O&M documentation.

## 2.13 Commissioning Plan

This is the project-specific document which has been approved by the PWGSC Commissioning Manager and which describes the process for verifying that all built works meet the Investor's requirements within the limits of the working documents.

The Commissioning Plan may, with the approval of the PWGSC Commissioning Manager, have to be amended by the contractor, then reviewed by the designer, at the commencement of construction in the light of the systems and equipment approved for installation, the contractor's construction/completion schedule and the occupancy schedule.

## 2.14 Installation/Start-up Check Lists

These are the lists to ensure that the equipment and systems as installed are complete, ready for start-up and for commissioning. The lists prepared by PWGSC must be considered as generic and illustrative only, and must be tailored to suit the project requirements.

### **2.15 Product Information (PI) and Performance Verification (PV) report forms**

These forms are used throughout the commissioning phase and indicate the basic requirements expected from the PV procedures. The samples provided by PWGSC should be considered as generic only and may need to be tailored to suit requirements of the project.

### **2.16 Commissioning of heritage buildings**

When changes are made to interior environments, commissioning should allow for ramping up to new set points over a period of weeks or months, rather than sudden start for new temperature and humidity levels. This allow for the building and its contents to adjust slowly to the changed conditions.

### **2.17 Building Management Manual**

Is fully described in *CP.4: Guide to the development of Building Management Manuals*. It consists of five discrete sections:

- Section 1: Containing names of participants, functional and operational requirements, description of the project and its systems, accessibility, any FHBRO statements.
- Section 2: Design criteria, design intents, design philosophy, applicable codes and standards.
- Section 3: Standard Operating Procedures and Operation and Maintenance (O&M) manuals.
- Section 4: Maintenance and service contracts.
- Section 5: Supporting appendices such as: architectural, structural, fire protection and fire prevention, mechanical, electrical, appendices, WHMIS information manual, O&M budget, “as-built” construction documents.

### **2.18 Commissioning reports**

These documents describe the commissioning processes used during the delivery cycle and provides assessment of the facility as to its compliance with the requirements identified in the IAR and the Project Brief.

### **2.19 Final Commissioning (Evaluation) Report**

The Final Commissioning, or Evaluation, Report is prepared by the PWGSC QA Commissioning Manager at the end of the project delivery stage, close out phase.

It is essentially a debriefing report and building evaluation summary and includes:

1. a complete assessment of the project.
- .2 lessons learned from this project and any necessary recommendations.
- .3 variances between the actual and planned levels of performance as defined in the IAR and Project Brief.
- .4 an evaluation of the validation and acceptance process and of the commissioning phase.
- .5 what components and systems which were not commissioned reasons for this
- .6 a remedial work plan outlining recommended follow-up actions or projects to be undertaken by PWGSC.
- .7 other related information.

## **2.20 Other documents**

The Project Leader may identify in the Project Brief other documents to be delivered. This may occur more often on projects for special purpose facilities.

**END**

**PWGSC  
COMMISSIONING MANUAL  
(CP.1)**

# **Project Commissioning**

## **Appendix A**

### **Samples of Commissioning Documentation**

Rather than being typical of what will be produced, with a few exceptions, this Appendix contains a number of sample commissioning documentation that has been prepared for projects that have been undertaken in NCA.

The items listed include:

Tab A:	Sample of Commissioning Brief
Tab B:	Sample of Commissioning Plan
Tab C:	Sample of Standard Operating Procedures Manual
Tab D:	Sample of Training Plan
Tab E:	Sample of Installation / Start-up Check List
Tab F:	Sample of MMS input into working documents
Tab G:	Sample of Product Information (PI) and Performance Verification (PV) Forms
Tab H:	Schematics used in Manuals and Commissioning Reports
Tab I:	Sample of Commissioning Schedules
Tab J:	Sample of Equipment Performance Verification specification
Tab K:	Sample of Integrated System specification

## **Sample of Commissioning Brief**

**NOTE:** *This is a sample (only) of the type of Commissioning Brief which might be used with a traditional type of Consultant Design / Contractor construct project.*

**A model generic Commissioning Brief may be found in CP.11: Guide to the preparation of Commissioning Briefs.**

### **IMPORTANT NOTES TO WRITER OF COMMISSIONING BRIEFS:**

1. This model Commissioning Brief has been developed **specifically for use with the traditional Consultant Design / Contractor construct type of project.**
2. This model Commissioning Brief shall be used in the preparation of project-specific Commissioning Briefs for new projects, existing installations where systems have to be substantially modified or for remaining existing systems as appropriate.
3. Material in this Commissioning Brief that is in *ITALICS* is for the benefit of the writer of the Commissioning Brief and is **NOT** intended to be incorporated into the Commissioning Brief.

### **1. Commissioning objectives**

The objectives of commissioning are:

- .1 To document the design intent of the overall project and the proposed building systems and components and to verify and demonstrate that all functional and operational requirements have been correctly interpreted in the Design solution.
- .2 To document the operational, maintenance and building management requirements.
- .3 To minimize O&M costs through the careful selection of design solutions (for economy, reliability, durability, accessibility, maintainability), construction materials, installation practices, performance verification procedures.
- .4 To verify that selected design solutions and the resultant built works protect the safety, health, welfare and comfort of occupants and O&M personnel.
- .5 To define responsibility areas for meeting these operational requirements in the contract documents and include a process to demonstrate compliance.
- 6 To demonstrate that the Client's and the Department's requirements are met during the project implementation and commissioning phases of the project and to support quality management of construction and installation through verification of building components, systems and environments.
- .7 To verify and demonstrate that all systems operate consistently at peak efficiencies, under all normal load conditions, and within the specified energy budget.
- .8 To provide comprehensive documentation of the operational, maintenance and building management.
- .9 To implement a comprehensive training program.
- .10 To transfer the completed works to qualified facility operators verifying that the building systems operate consistently at peak efficiencies, under all normal load conditions, and within the specified energy budget.
- .11 To ensure the heritage character of the building is protected through appropriate maintenance schedules, methods, materials and procedures.

### **2. General description of commissioning**

- .1 Commissioning shall be carried out in accordance with the **PWGSC Commissioning Manual (CP.1)** , current edition, and all associated Guidelines but suited to the specific requirements of the project. These documents consist of:
  - CP.1: Project Commissioning Manual*
  - CP.2: Commissioning Glossary (forms Appendix B of CP.1)*
  - CP.3: Guide to development of the Commissioning Plan*
  - CP.4: Guide to the development of the Building Management Manual*
  - CP.5: Guide to preparation of Training Plans*
  - CP.7: Commissioning for Facilities Management and Operation*
  - CP.8: Guide to the preparation of Commissioning Reports*
  - CP.9: Guide to the development and use of Check Lists*
  - CP.10: Guide to the development and use of Report Forms and Schematics*
  - CP.11: Guide to the preparation of Commissioning Briefs*
  - CP.12: Guide to the development and use of Commissioning specifications*
  - CP.13: Facility Maintenance Policy, Guidelines and Requirements*
  
- .2 The **PWGSC Commissioning Manual (CP.1)** and all associated PWGSC Guidelines are available from the Project Manager.
  
- .3 Commissioning includes architectural, structural, interior and landscape systems, as well as the usual mechanical and electrical systems.
  
- .4 The Designer must deliver concise and comprehensive information and reports on commissioning to PWGSC.
  
- .5 A enhanced commissioning program is required and will apply to all construction phases , base building and fit up work.
  
3. **Roles and responsibilities:**
  - .1 **PWGSC Project Manager:** Has overall responsibility for managing the project and delivering the project to the Project Leader on time and on budget. Upon completion, the Project Manager hands the facility over to the Project Leader.
  
  - .2 **PWGSC Commissioning Manager:** As a member of the PWGSC Technical Advisory Team, the Commissioning Manager:
    - .1 represents the Project Manager during the commissioning process;
    - .2 maintains overall responsibility for representing the Client's interests in the implementation of commissioning, including:
      - .1 assuring that all program issues have been addressed,
      - .2 reviewing all documentation at all stages of project development and delivery,
      - .3 monitoring of all commissioning activities,
      - .4 verification of the accuracy of all reported results.
    - .3 ensures that all O&M aspects are addressed to the satisfaction of the Department,
    - .4 reviews Designer's submissions,
    - .5 monitors the Designer's commissioning services during the commissioning process,
    - .6 witnesses and certifies with the developer's designer all integrated systems test results,



- .7 in consultation with the Designer, review staffing, service contracts and requirements for supply and storage of spare parts, special tools and maintenance materials.

**.3 Designer (Consultant):** The Designer shall:

- .1 establish Design Criteria, functional and operational requirements, if not already established in the RFP or Project Brief,
- .2 establish a Design Energy Budget and, if necessary, revise and update with each submission,
- .3 prepare a preliminary O&M budget and revise and update with each submission, containing detailed breakdowns of various items such as estimated electrical, mechanical, or specialty equipment annual energy consumption and systems maintenance, operation and/or service contract costs,
- .4 prepare a preliminary Commissioning Budget and revise and update with each submission,
- .5 prepare a preliminary Commissioning Plan in accordance with *CP.3: Guide to development of the Commissioning Plan*,
- .6 prepare commissioning specifications for components, equipment, systems and integrated systems in accordance with *CP.12: Guide to the development and use of Commissioning Specifications* and incorporate same into the construction specifications,
- .7 prepare a complete maintenance management documentation in accordance with *CP.4: Guide to the preparation of Building Management Manuals*, to be sufficiently complete for use during training, and to include:
  - .1 explanation of the purpose of the facilities, what the building is meant to do,
  - .2 outline of the design intent of all systems,
  - .3 provide a narrative description of the project's conceptual framework,
  - .4 document all design decisions made throughout the project,
  - .5 description of each building system; including architectural, structural, mechanical, electrical, civil, fire protection, acoustical and other building as well as site systems,
  - .6 include all relevant documentation.
- .8 plan the commissioning and performance verification (PV) activities, processes and their output, including development of project-specific:
  - .1 Installation / Start-up Check Lists prepared in accordance with *CP.9: Guide to the development and use of Check Lists*,
  - .2 Product Information (PI) Report Forms and Performance Verification (PV) Report Forms prepared in accordance with *CP.10: Guide to the development and use of Report Forms and Schematics*,
  - .3 Add all design data to PI and PV report forms.
- .9 prepare a detailed Training plan in accordance with *CP.5: Guide to preparation of Training Plans*,
- .10 incorporate PWGSC MMS identification codes to all components, equipment and systems into all working documents; all in accordance with *CP.13: Facility Maintenance Policy, Guidelines and Requirements*,
- .11 review the **CONTRACTOR'S** detailed commissioning schedule for components, equipment, systems, and integrated systems. (PV tests will be performed by the Contractor),
- .12 identify Contractor and subcontractor commissioning, PV and testing responsibilities,

- .13 review shop drawings and product data and accompanying Product Information (PI) as completed by the Contractor,
  - .14 monitor commissioning activities, provide quality control reports to the PWGSC commissioning Manager throughout the construction, commissioning and operational phases of the work, including but not necessarily limited to:
    - .1 inspection and verification of as installed components, sub system and systems on a regular basis during construction,
    - .2 witnessing tests, as required by PWGSC,
    - .3 reviewing and verifying testing, adjusting and balancing (TAB) reports,
    - .4 reviewing and verifying Performance Verification (PV) Reports prepared in accordance with *CP.8: Guide to the preparation and use of Commissioning Reports*,
    - .5 witness and certifying systems and integrated systems tests,
    - .6 any test which cannot be commissioned due to design errors or omission has to be redesigned and recommissioned.
  - .15 participate in the Training Plan by providing training on design philosophy, design intent and systems designs,
  - .16 witness and certify deferred tests, commissioning activities, PV, review and accept reports,
  - .17 identify and verify the rectification of all outstanding deficiencies,
  - .18 assist in the resolution of all issues relating to commissioning,
  - .19 prepare “as-built” documentation (plans and specifications) as described elsewhere in the RFP or Project Brief,
  - .20 assist in fine-tuning of systems and equipment as required during the warranty period,
  - .21 coordinate with the PWGSC Commissioning Manager to ensure that O&M requirements are addressed,
  - .22 assist in systems checks and environmental checks during the warranty period,
  - .23 participation in warranty inspections and production of warranty inspection reports and address all warranty issues that may arise,
  - .24 ensure that the final product meets the Design Criteria, functional and operational requirements, the project objectives and all requirements of the RFP and Project Brief,
  - .25 recommend acceptance of the completed project,
  - .26 assist the PWGSC project manager in the preparation of a debriefing (Evaluation) report. To include, but not necessarily be limited to:
    - .1 a building evaluation summary with recommendations,
    - .2 lessons learned from the project.
- .4 Designer’s commissioning resource:** To assist in fulfilling a fully integrated and comprehensive commissioning program, the Designer shall appoint a full-time commissioning resource with proven expertise in implementing commissioning programs, and who shall be responsible for detailed coordination of commissioning and provide direction for all matter relating to commissioning as described herein. The name of this resource shall be provided to the PWGSC Project Manager and Commissioning Manager .
- .5 Contractor:** In accordance with the commissioning requirements specified in the Construction Documents, the Contractor:
- .1 develops a critical path commissioning activities schedule for review and approval of the Designer, PWGSC Commissioning Manager and Project Manager,
  - .2 executes all commissioning activities in accordance with the Contract Documents, such as:

- .1 input data from drawings on to Product Information (PI) Report Forms,
- .2 assemble maintenance sections of the Building Management Manual as described in *CP.4 - Guide to the preparation of Building Management Manuals*,
- .3 assist in assembly of section relating to operation of components, equipment, sub-systems, systems and integrated systems as described in *CP.4: Guide to the preparation of Building Management Manuals*,
- .4 utilize Installation/Start-up Check Lists when conducting pre-start-up inspections,
- .5 coordinate all commissioning activities,
- .6 perform testing, adjusting and balancing (TAB), prepare TAB reports,
- .7 conduct performance verification (PV) tests of components, equipment, sub-systems, systems and integrated systems, complete PV Report Forms, prepare PV Reports,
- .8 coordinate and implement training as described in *CP.5: Guide to preparation of Training Plans*,
- .9 address all issues relating to commissioning,
- .10 assist the Designer in the preparation of commissioning documentation,
- .11 assist the Designer in the preparation of "as-built" documentation,
- .12 fine-tune components, equipment, sub-systems, systems and integrated systems during the warranty period,
- .13 perform systems and environmental checks during warranty period and prepare reports,
- .14 address all warranty issues,
- .15 provide input to the Designer in the preparation of a debriefing (Evaluation) report.

- .6 Contractor's commissioning resource**, assigned by the Contractor, qualified and experienced in the implementation of all commissioning, to coordinate, direct and verify all commissioning activities and procedures. The name of this resource shall be provided to the PWGSC Project Manager and PWGSC Commissioning Manager for approval.

#### **4. Occupancy requirements**

Identify facility management requirements, including move-in procedures; security systems; staffing; signage; safety and accessibility for persons with disabilities.

User occupancy requirements include consideration of the need for and implications of:

- .1 early, late and/or phased completion, take-over, acceptance and occupancy, including the effects upon the User's present accommodation (such as early decommissioning, need for extension etc.).
- .2 requirements for initial, interim and substantial occupancy including, for reasons of health and safety, full commissioning of all life safety systems. It may also include some form of "interim commissioning" of all non-life safety systems.

- .3 overlapping of construction, commissioning and initial occupancy. This requires consideration of the effects of partial commissioning, delay of commissioning activities, the effects on insurance, warranties, certification, repetition of commissioning activities after full occupancy, and/or completion of fit-up contracts.
- .4 post-occupancy commissioning activities during Operation which will often be necessary for certain systems and equipment under these circumstances.

**5. Operational criteria**

**NOTES TO READER :**

- 1. *This paragraph applies mainly to renovation projects.*
- 2. *Rewrite this paragraph to suit project requirements.*

- .1 [This building will be decommissioned during the renovation and construction process and the Contractor will bear the full responsibility for the base building.]  
or  
[This building will be occupied during the demolition, construction and fit-up process. Part of the building will be decommissioned during the first construction (demolition) contract. The Contractor will bear full responsibility for the base building].  
or  
[This building will be partially occupied during the demolition, construction and fit-up process. Part of the building will be decommissioned during the first construction (demolition) contract].
- .2 The Contractor may use base building systems, utilities and steam from the Central Heating Plant during renovation stages. The cost for energy used will be borne by [PWGSC] [the Contractor].
- .3 [Start-up, PV and acceptance will include phased activities (both within individual contracts and involving several contracts). Testing, PV, commissioning and training must be developed bearing these variables in mind. Cooperate and coordinate testing procedures and schedule with user. Once the renovated building has been occupied, further testing activities will be subject to User's approval and may be refused during normal working hours].  
or  
[Start-up, PV and acceptance will include phased activities (both within individual contracts and involving several contracts). Testing, PV, commissioning and training must be developed bearing these variables in mind. For example:

*NOTE TO READER: Modify this table to suit the project*

Nominal hours of operation/occupancy:	0600 - 1800, [5] days/week
Extended hours of operation/occupancy:	1800 - 0600, [5] days/week
Nominal hrs. of operation (presence) of O&M staff:	0830 - 1600, 5 days/week
Security staff presence:	24 hours/day, 7 days/week
Cafeteria and meeting rooms:	[0700 - 2100] [varies], 7 days/week
Restrictions to testing:	Life-support: Off-hours Emergency power: Off-hours
Ventilation for off-gassing:	[During occupied periods and] during off-hours for first [8] weeks after completion of installation of furnishings].

Once the renovated building has been occupied, further testing activities will be subject to User's approval and may be refused during normal working hours.

**6. Life cycle costing criteria**

If not prescribed within the RFP or Project Brief, when developing life cycle cost analyses for each option, use the following criteria:

1. [25] years to next refit,
2. [50] year investment horizon,
3. costs of utilities (e.g. Central Heating and Cooling Plant (CHCP) steam, hot water heating, chilled water, electricity), fuel consumption, potable water and sewage),
4. reliability, durability, operability, maintainability, accessibility and serviceability,
5. systems selection and staffing in response to annual operating cost criteria.

## **7 Cooperation and coordination**

Throughout the Commissioning Process, the Project Design Team, the Project Construction Team, the Project Commissioning Team, and the Property Management Team, all as defined in *The PWGSC Commissioning Manual (CP.1)*, will work closely together to implement all commissioning activities.

## **8 Training**

In consultation with the PWGSC Commissioning Manager, prepare a comprehensive training plan for the training of the Facility Management personnel, User (where deemed necessary) and operations and maintenance staff.

If required by the RFP or the Project Brief, training shall be in English and French.

The training plan which will enable O&M personnel to identify repair and maintenance needs that might otherwise go undetected for long periods with possibly serious consequences.

Training shall enhance monitoring and diagnostic capabilities and result in more efficient, cost-effective operation of the facility.

The training plan shall be in accordance with the requirements of *CP.5 Guide to preparation of Training Plans*. Training plans shall be reviewed, revised, updated and resubmitted as required.

The names of all trainees (obtained from the PWGSC Project Manager) and all training personnel shall be submitted to the PWGSC Project Manager for review, comment and approval at least two (2) weeks prior to the proposed training dates.

Training must clearly relay:

- .1 A clear understanding of the intent of the design,
- .2 All limitations of the systems,
- .3 Reasons for the choice of systems.

Coordinate the dates of all training sessions with the PWGSC Project Manager. Update the training plan as required to reflect the project schedule. The PWGSC Project Manager will organize the location

The training plan shall recognize both short-term and long-term requirements.

Upon completion, prepare a summary of the training sessions, indicating dates, subject matter, all training personnel and all trainees present and submit to the Project Manager.

## **9 Correction of deficiencies**

The Designer, in consultation with the PWGSC Commissioning Manager, shall:

- .1 instruct the contractor to correct all the deficiencies identified and recorded during the performance verification,
- .2 provide solutions during the PV process with respect to the variances from the design parameters,
- .3 adjust or alter the systems to achieve the design parameters. This shall include re-testing,
- .4 immediately notify the PWGSC Project Manager when tests fail to meet project requirements and when corrective work and re-tests affect construction and completion schedule,
- .5 report in writing to the PWGSC Project Manager and the PWGSC Commissioning Manager indicating compliance or anomalies regarding witnessed events. The consultant is to investigate and recommend in writing any corrective actions to be taken to facilitate compliance with design intent and design criteria.

## **10 Facility maintenance policy, guidelines and requirements**

For full details, the Designer shall refer to *CP.13: Facility Maintenance Policy, Guidelines and Requirements*.

## **11. Acceptance of the project**

The project will be accepted and the Interim Certificate of Completion will be issued only after:

1. successful completion of all integrated systems tests, life safety support systems tests and after all other requirements of the authority having jurisdiction are satisfied,
2. all test certificates, commissioning reports and commissioning documentation have been approved and accepted by the PWGSC Project Manager.

## **12. Commissioning documentation**

Commissioning documentation is a complete set of data and information fully describing the completed project as a built, finished, functional and operational facility and presented in a form that can be maintained, updated and used over the life of the building.

In preparing project-specific commissioning documentation, use all existing generic commissioning documentation to the maximum extent possible. However, the Designer retains over-riding responsibility for the content of all project-specific commissioning documentation and for editing, amending and supplementing as required and as is appropriate for the project.

Produce in accordance with the requirements of *The PWGSC Commissioning Manual (CP.1)* in consultation with PWGSC centre of expertise and the PWGSC Commissioning Manager as appropriate.

Comply with all requirements contained in the RFP relating to electronic production of commissioning documentation.

Commissioning documentation shall include:

- .1 The Commissioning Plan**, the master planning document for all commissioning activities and deliverables, revised, refined, updated and reviewed at each stage of design development and re-submitted for review by the PWGSC Commissioning Manager. Use the PWGSC Model Commissioning Plan (see CP.3) as a reference model.
- .2 The Building Management Manual**, containing all documentation for the project and providing a complete “paper trail” relating to project delivery. Responsibilities for development and timing of delivery are described in *CP.4: Guide to the development of Building Management Manuals*.
- .3 Commissioning specifications**. For details of requirements, refer to *CP.12 - Guide to the development and use of Commissioning Specifications*.
- .4 Training Plans**. Refer to *CP.5 Guide to the preparation of Training Plans*. For more details refer to relevant paragraph below.
- .5 Installation Check Lists** for use during pre-start-up and pre-commissioning inspections. Refer to *CP.9 Guide to the development and use of Check Lists*.
- .6 Product Information (PI) report forms** to document all details of equipment, components and systems - refer to *CP.10 Guide to the development and use of Report Forms and Schematics*.
- .7 Performance Verification (PV) report forms** and include thereon all Design Criteria, Design Intents and other relevant design information. Refer to *CP.10 Guide to the development and use of Report Forms and Schematics*.
- .8 MMS requirements**, Apply to all drawings before Tender call . Refer to *CP.13 Facility Maintenance Policy, Guidelines and Requirements*.
- .9 "As-built" drawings and specifications:** to be completed prior to, and available for, pre-start-up inspections and to include:
  - .1 amendments to show all measured and approved results of PV procedures, settings of all controls, systems and equipment as finally set upon completion of commissioning,
  - .2 project specifications amended by insertion of addenda, change notices, etc. ,
  - .3 flow diagrams and piping schematics as installed at each major item of equipment complete with valves controllers, etc., identified with numbered tags.
- .10 Occupants' Comments/Complaints Audit System** for use during the Warranty Period.
- .11 TAB and commissioning reports** to be prepared in accordance with *CP.8: Guide to the preparation and use of Commissioning Reports*.
- .12. Final evaluation report**, in accordance with *CP.8: Guide to the preparation and use of Commissioning Reports*.
- .13 Any other documents and reports**

**13 Commissioning deliverables:**

- .1 First technical submission by the Designer:** Provide following:
  - .1 Conceptual Design Report:** From the commissioning perspective, the Conceptual Design Report shall include:
    - .1 description of the design** describing the Design Criteria, Design Intent, the design philosophy, the rationale for system selection based on life cycle cost analysis, the functional and operational requirements and the conceptual framework for the operation and use of the proposed building, its components and systems, how the proposed design meets the Client's requirements, corporate and project objectives. To be updated at each stage of project development.
    - .2 design criteria, Design intents,**
    - .3 O&M Report.** To include:
      - .1 O&M budget including projected utility consumption
      - .2 spatial requirements for O&M staff (office, lockers, kitchen, showers, washrooms, flow of people and supplies, storage for special tools, spare parts, and maintenance materials),
      - .3 cleaning requirements (janitor closets, receptacle for vacuum, equipment supply and storage),
      - .4 other requirements associated with O&M aspects including, but not necessarily limited to:
        - .1 operating standards and operator requirements,
        - .2 equipment and system reliability requirements,
        - .3 delivery, content and form of O&M documentation,
        - .4 tools, equipment, spare parts and maintenance materials,
        - .5 emergency procedures,
        - .6 identification and other similar needs,
        - .7 waste management requirements,
        - .8 preventive maintenance tasks.Further information may be obtained from *CP.7: "Commissioning for Facility Management and Operation"*.
    - .4 Comprehensive documentation, design information/data** and comments to allow the PWGSC Commissioning Manager to:
      - .1 prepare service and staffing contracts,
      - .2 prepare a list of spare parts, special tools, maintenance materials and other special equipment to be provided by the Contractor.
    - .5** capacity of the facility to change in response to program changes over its life expectancy,
    - .6** requirements for operation and maintenance of the project over its life expectancy,
    - .7** occupancy during construction,
    - .8** "phased" construction program,



- .9 assessment of staffing and skill requirements to operate and maintain the project,
- .10 preliminary commissioning plan,
- .11 sample of PI/PV report forms and tracking software,
- .12 preliminary building management manual,
- .13 define project archives and how these archives will be managed, updated, and submitted at the end of the project.

**.2 33% Submission:**

- .1 Extent of commissioning determined,
- .2 Factory and on-site tests of components, sub-systems, systems and integrated systems during construction, installation and commissioning determined,
- .3 Outline commissioning specifications using PWGSC generic commissioning specifications PLUS outline project-specific commissioning specifications,
- .4 Updated Commissioning Plan,
- .5 Updated Building management manual,
- .6 Updated Design Intent Document,
- .7 Updated O&M Budget,
- .8 Outline PI and PV forms. Provide for all components, equipment and systems to be tested,
- .9 Maintenance management system (MMS) codes identified for all equipment shown on the construction documents,
- .10 Preliminary Training Plan.

**.3 66% Submission:**

- .1 Factory and on-site tests of components, sub-systems, systems and integrated systems during construction, installation and commissioning defined and detailed in commissioning specs,
- .2 Commissioning activities to be deferred to Operational Phase and Warranty Period identified,
- .3 Detailed commissioning specifications,
- .4 Updated Commissioning Plan, etc.,
- .5 Detailed Building management manual,
- .6 Updated Design Intent Document,
- .7 Updated O&M Budget,
- .8 Updated Training Plan,
- .9 Maintenance Management System (MMS) codes identified for all equipment shown on the construction documents, schematics and line diagrams,

- .10 Complete PI and PV forms. Provide for all components, equipment and systems to be tested.

**.4 99% Submission:**

- .1 Commissioning specifications integrated into project specifications,
- .2 90% Commissioning plan,
- .3 90% complete Building Management Manual,
- .4 90% Design intent document detailing each building system, including all engineering calculations,
- .5 Final O&M Budget,
- .6 Maintenance Management System (MMS) codes identifiers shown on the construction documents and indicated on each PI and PV form,
- .7 100% Training Plan, indicating scope and duration of training,
- .8 Design information added to PI forms.

**.5 100% Submission:**

- .1 This submission incorporates all revisions required by the review of the 99% submission,
- .2 Complete Commissioning Plan,
- .3 Update the design intent document to reflect any changes from the 99% submission.

**14 Construction and Commissioning:**

**.1 General:**

- .1 Upon Contract award, review and Update the PI and PV Forms, installation/start-up Check Lists, Commissioning Plan, Training Plan, commissioning specifications, and Commissioning Schedule to ensure relevance to construction changes to the work. Refer to *CP.9 - Guide to the development and use of Check Lists*, and *CP.10 - Guide to the development and use of Report Forms and Schematics*.
- .2 In consultation with the Contractor, review/select the test instruments to be used and instrument calibration.
- .3 Incorporate relevant data from approved shop drawings and installed component data immediately upon approval.
- .4 Review contractors compliance with the contract documents.
- .5 Witness and certify tests, including those tests conducted before concealment and start up.
- .6 Verify that each system is completed, safe to operate and ready for start-up.
- .7 Review all test reports and take necessary action with Contractor when work fails to comply with contract.
- .8 Immediately notify the PWGSC Project Manager when tests fail to meet project requirements and when corrective work will affect schedule.

- .9 Ensure that all deficiencies are rectified and acknowledge that the installation of components and systems is ready for the commissioning phase.
  - .10 Assist Departmental Representative in evaluating testing firm's invoices for services performed.
  - .11 Review all maintenance management nomenclature and submissions prepared by the contractor. Ensure completion of on-site implementation and tagging of systems and equipment.
- .2 Manuals and Reports** - Refer to *CP.4 - Guide to the development of Building Management Manuals*:
- .1 4 weeks before training is due to commence, assemble, review and approve:
    - .1 All commissioning documentation, including PV documentation, procedures and expected output.
    - .2 In consultation with the Contractor, review/select the test instruments to be used and instrument calibration.
    - .3 Revise the Building Management Manual as construction progresses, ensuring that it reflects the installed systems.
    - .4 Finalize the SOP Manual: Verify, and certify, completeness, relevance and accuracy. Produce [4] sets and submit to the PWGSC Project Manager prior to implementation of Training Plan. The Contractor shall retain one copy of each volume for his record and for use during the implementation of the Training Plan.
    - .5 Review the O&M Manual: Verify for, and certify, completeness, accuracy, relevance and format. Submit [4] sets to the PWGSC Project Manager in accordance with Section [01730][01732][01007] of project specification prior to interim acceptance or implementation of Training Plan. Ensure Contractor assembles all certified tests results and incorporates into the O&M manuals. The Contractor shall retain one copy of each volume for his record and use during the instruction period.
- .3 Training:** Implement the Training Plan. Refer to *CP.5 - Guide to the development of Training Plans*.
- .1 Submit the Training Plan to the PWGSC Project Manager for review and comment at least two weeks prior to the proposed training dates. Update and resubmit as required. Include an agenda and a course outline summarizing the content and duration of training. The training provided must clearly relay:
    - .1 An understanding of the intent of the design.
    - .2 Limitations of the systems.
    - .3 Reasons for the choice of systems.
  - .2 Coordinate the date(s) of the training session(s) with the PWGSC Project Manager. The PWGSC Project Manager to organize the location and provide the lists of participants.

- .3 Prepare a summary of the training sessions. Indicate dates, subject matter, and all personnel present for training. After training, submit the training summary to the PWGSC Project Manager.
- .4 Make necessary arrangement for site O&M staff familiarization during construction/ installation.
- .5 Consultant to provide training sessions on design intent and operational philosophy of each building system, including architectural systems, and the integrated building systems (all together). Utilize the O&M Manual and design intent document for training sessions.
- .6 Contractor to provide training sessions on the operations and maintenance of components, equipment, sub-systems, systems and integrated systems.
- .7 Record the time, date and subject matter of training sessions as they occur. Indicate all those who are present at each training session.

**.4 Spare Parts:**

- .1 Finalize the delivery, inventory and storage of all specified spare parts, special tools, maintenance materials.

**.5 Component, sub-systems, Systems, and Integrated System Performance Verification (PV)**

- .1 Test all the components, subsystems, systems and integrated systems in accordance with the provisions of the contract documents, Ensure the work meets the design intent and requirements of ULC and TB Guidelines on Life Safety and Health. The Designer shall witness, certify and approve all tests.
- .2 Certify and date all PV procedures and test results.
- .3 Report in writing to the PWGSC Project Manager and PWGSC Commissioning Manager indicating compliance or anomalies regarding witnessed events. The consultant is to investigate and recommend in writing any corrective actions to be taken to facilitate compliance with design intent and design criteria.
- .4 Provide solutions during the PV process with respect to the variances from the design parameters.
- .5 In consultation with the PWGSC Commissioning Manager, instruct the contractor to rectify all deficiencies identified and recorded during the performance verification and adjust or alter the systems to achieve the design parameters. Re-test to verify compliance.
- .6 In consultation with the PWGSC Commissioning Manager, and PWGSC Project Manager, recommend take over of the facility subject to performance of PV and commissioning which were previously agreed to be deferred until the operational phase.
- .7 Prior to interim inspection, debrief the PWGSC Project Manager and the PWGSC Commissioning Manager on the commissioning process including training; problems; required changes to systems (with costs) which are outside the contractor's responsibility, but which are deemed necessary to meet project requirements; commissioning procedures and other information, experiences and suggestions for future projects. Submit a

report to the PWGSC Commissioning Manager. Repeat this process when 80% occupancy is achieved.

**.6 Design intent document and Building Management Manual:**

- .1 Update the design intent document and Building Management Manual. Immediately prior to the issuance of the Interim Certificate of Acceptance develop this document so as to become the complete “Building Management Manual” to reflect the final as-built works. Reflect all changes, modifications, revisions and adjustments. This may include the incorporation of reports such as *the Area Measurement and Space Usage Report*, Fire protection Manual, etc.

**END**

**CP.11: MODEL COMMISSIONING BRIEF**

## Sample of Commissioning Plan

**NOTE:** *This is a sample (only) of the type of Commissioning Plan which might be used with the normal type of Consultant Design and Contractor construct project for upgrading, extending, and replacing existing laboratory facilities.*

PWGSC Project no. xxx xxx [ project title ] [ date ]

### Contents

1. Importance of the Commissioning Plan
2. Roles and responsibilities
3. Revisions to this Commissioning Plan
4. Risk assessment
5. Objectives of commissioning
6. Extent of commissioning
7. Deliverables relating to O&M perspectives
8. Deliverables relating to the commissioning process
9. Deliverables relating to the administration of commissioning
10. Payments for commissioning
11. The commissioning process
12. Training Plan

### 1. Importance of the Commissioning Plan

The Commissioning Plan is the master planning, management and communications tool relating to commissioning, setting out scope, standards, roles and responsibilities, expectations, deliverables, etc., and is addressed to all members of the Commissioning Team. It provides an overview of commissioning, and sets out the process and the methodology for successful commissioning of the above-mentioned project.

### 2. Roles and responsibilities

The Commissioning Plan is intended to be used by the:

- .1 PWGSC Project Manager:** who has the overall responsibility for the project and is the sole point of contact between the Client, the Designer, the PWGSC Commissioning Manager and all other members of the project team.
- .2 PWGSC design Quality Review Team:** conducts detailed reviews during all stages of the design to ensure appropriate design criteria, design intents, design solutions, that designs are well-developed, commissioning specifications are appropriate to this laboratory, transmits technical design information to the Designer. During construction, may conduct periodic site reviews to observe general progress.
- .3 PWGSC Commissioning Manager:** ensures that all commissioning activities are carried out so as to ensure the delivery of a fully operational project complete in every respect.. This includes reviews of all commissioning documentation, reviews for performance, reliability, durability of operation, accessibility, maintainability, operational efficiency under all conditions of operation, protection of health, welfare, safety and comfort of occupants and O&M personnel.
- .4 Designer (i.e.. Consultant):** designs the facility to meet the Client's functional and operational requirements and budget, prepares all working documents, including incorporation of commissioning specifications in to construction specifications, monitoring commissioning activities, witnessing and certifying the accuracy of reported results, witnessing and certifying TAB and other tests, develops the PI and PV Report Forms,

develops the Building Management Manual, ensures the implementation of this Commissioning Plan, performing verification of performance of all installed systems, implementation of Training Plan.

- .5 **Construction Team:** consists of Contractor, sub-contractors, suppliers and other support disciplines, and is responsible for construction/installation in accordance with the contract documents, including testing and the delivery of training, required documentation.
- .6 **Contractor's Commissioning Agent:** to implement all commissioning activities required by the specifications, including demonstrations, training, testing, preparation and submission of test reports.. This is a responsibility that is distinct from that of the Contractor's site supervisor. Commissioning Agent to be available for emergency and troubleshooting service during the first year of occupancy by the User for adjustments and modifications outside the responsibility of the O&M personnel.
- .7 **Commissioning Agencies:** will include:
  - .1 **The installing contractor** or installing sub-contractor.
  - .2 **Equipment manufacturer:** e.g.. elevators, emergency generators.
  - .3 **Specialist sub-contractor:** e.g.. EMCS.
  - .4 **Specialist commissioning agency:** e.g., environmental space conditions, indoor air quality and other installations providing environments which are essential to the Client's program but are outside the scope or expertise of other Commissioning Agencies on this project. If not specified in the commissioning specifications, the identity of this specialist will be provided at a later date.
  - .5 **TAB agency:** equipment and systems involving the measurement and adjusting of flow rates and pressures to meet indicated or specified values (e.g. ducted air and hydronic systems, fans, pumps).

All Commissioning Agencies will be available for emergency service during the first year of occupancy by the User for adjustments and modifications outside the responsibility of the O&M personnel. These include changes to ventilation rates to meet changes in off-gassing, changes to heating or cooling loads beyond the ranges of the EMCS, and changes to EMCS control strategies beyond the training level provided to the O&M personnel.

The names of commissioning personnel, details of the instruments which will be used and commissioning procedures which will be followed will be provided at least three months prior to the scheduled starting date so as to permit proper review and approvals.

- .8 **Client's move:** the move from the existing accommodation into the new building, although not part of commissioning should be given serious consideration by the Designer so as to ensure only very minor interruption in his program activities.
- .9 **Property Manager:** has responsibility for receiving the renovated facility and is responsible for day-to-day operation and maintenance of the facility and represents the lead role in the Operation Phase and onwards.

### 3. **Revisions to this Commissioning Plan**

This Commissioning Plan will be reviewed, revised, refined and updated as detailed design and production of the Working Documents proceeds and, if required, during construction.

Each time it is revised, the revision number and date will also be revised. The revised Commissioning Plan shall be submitted to the PWGSC Project Manager and PWGSC Commissioning Manager for review and approval.

**4. Risk assessment**

For the construction of Laboratory Buildings, the performance of each system will affect the performance of all other systems, and non-performance places the conclusions of scientific research at very considerable risk (with possible negative impact on confidence by the scientific community in the reliability of such research). It is planned, therefore, to verify the performance of all systems and equipment installed in the new Laboratory building before acceptance by the User.

**5. Objectives of commissioning**

Commissioning will provide a fully functional facility:

- .1 whose systems, equipment and components have been proven to meet all Client's functional requirements before the date of acceptance, and operate consistently at peak efficiencies and within specified energy budgets under all normal loads.
- .2 in which the Client and O&M personnel will have been fully trained in all aspects of all installed systems,
- .3 having optimized life cycle costs,
- .4 having complete documentation relating to all installed equipment and systems.

**6. Extent of commissioning**

Since this preliminary Commissioning Plan is based upon the RFP and has been prepared prior to the development of the Conceptual Design Report, it is possible at this time to refer to systems only in very general terms. Systems to be commissioned shall include:

**.1 Architectural and Structural**

- o Accessibility and operational safety
- o Raised floor systems
- o Elevator service \*\*
- o Vertical transportation systems \*\*
- o Kitchen equipment
- o Special doors in laboratories
- o Door and window hardware
- o Protection of heritage character of this building

**.2 Mechanical**

- o Environmental control systems, indoor space conditions, IAQ, noise & vibration
- o Exhaust systems and related make-up systems
- o Heat recovery systems
- o Smoke control systems \*\*
- o Plumbing and other building services
- o Fire suppression and fire protection systems \*\*

**.3 Electrical**

- o High voltage switch gear and transformation equipment and distribution systems
- o Low voltage (below 750 V) distribution systems
- o Emergency power generation, uninterruptible power, battery systems, lighting \*\*
- o Lighting equipment and distribution systems \*\*



- Fire exit emergency signage \*\*
- Transfer switches, controllers, fire alarm systems, control panels, enunciators \*\*
- Voice communications and audio/video systems \*\*
- Electronic data and communications information systems
- Intrusion and access security and safety systems \*\*
- Lightning protection systems

\*\* . These systems are identified as life safety systems.

## 7. Deliverables relating to O&M perspectives

The following list of deliverables is a brief overview. The Designer shall utilize a computer-based data management system. This will include the cost of all labour, material and EDP equipment to deliver the program (e.g. "as-built" drawings and specifications, PV and commissioning documentation, Building Manual, Training Plan). Separate manuals shall be compiled – one in French, one in English. Deliverables will include duplicate discs and [two] hard copies. All documentation shall be required to be transferred to the Property Manager in a computer-compatible format that can be readily inputted for data management.

- .1 Facility Operation and Maintenance Report:** This is a study to show how the facility will be operated. It will include the number of O&M personnel, security staff, janitorial staff, O&M spatial requirements, organization relating to flow of materials into and out of the facility, etc. It will be prepared by the Designer with input from the PWGSC Commissioning Manager and the Property Manager [and User].
- .2 Operation and maintenance budget:** This will be based upon the Facility O&M Report. As the design develops, it will include breakdowns to show the various elements of operations and maintenance (e.g. cleaning, service contracts), etc. It will be prepared by the Designer with input from the PWGSC Design Quality Review Team, the PWGSC Commissioning Manager and Property Manager and Client.
- .3 Design energy budget:** This will be prepared by the Designer with input from the PWGSC Commissioning Manager and the PWGSC Design Quality Review Team, and presented with the Conceptual Design Report. To be updated at the completion of the working documents.
- .4 Building Management Manual:** This will provide comprehensive information relating to the design, implementation, operation and maintenance of the entire project. It will include, but not necessarily limited to the following:
  - .1 Standard Operating Procedures (SOP) Manual:** To include description of each system together with a description of all operating modes. It will be produced by the Designer as the design develops. It shall be 90% complete prior to Tender Call. During the commissioning phase, revisions and refinements will be incorporated by the Designer, so that it will be 100% complete prior to issuance of the Interim Certificate. It will be further refined during the Warranty Period when all systems undergo fine tuning, set-point adjustments are made, etc.
  - .2 Operating and Maintenance (O&M) Manual:** This will be produced by the Contractor as construction/installation proceeds and reviewed by the Designer. It will be 90% complete prior to start-up inspections. During the commissioning stage, all missing data will be added, so that it will be 100% complete prior to issuance of

the Interim Certificate. During the Warranty Period, it will be refined as required. This manual will be organized so that keeping it up-to-date will require minimum time and resources.

- .3 Life Safety Compliance (LSC):** Emergency information relating to all possible emergencies such as the presence of smoke, fire, floods, gas, failure of electrical power, water supply, heating, cooling, elevators, escalators, emergency evacuation, refrigerant release, chemical spills, heating and cooling generation plant emergencies, failure of fuel supplies and breach of security. Information is to be immediately available and comprehensible to technical and non-technical users. This manual is to be based upon the PWGSC LSC Manual, but enhanced to be made facility specific. Samples of existing LSC Manuals are available from the PWGSC Commissioning Manager for reference purposes.
- .4 WHMIS information:** separate binder containing all information relating to products used in building operation and maintenance. This manual is to be subdivided by supplier, then by product. A detailed index is to appear at the beginning of the manual.
- .5 Way-finding signage:** referred to in Part 1: General Project Requirements. To follow the Treasury Board Federal Identity Program Manual.
- .6 Performance verification tests and inspections conducted at factory:** These will be witnessed by the PWGSC Design Quality Review Team and witnessed and certified by the Designer. The PWGSC Commissioning Manager may elect to participate.
- .7 Warranties:** A complete inventory will be provided by the Contractor to the Designer who will review same before submission to the PWGSC Commissioning Manager who, in turn, recommends acceptance by the PWGSC Project Manager.
- .8 Service Contracts** Although service contracts are not part of commissioning, the Designer and the PWGSC Commissioning Manager will assist the Property Manager in development by providing a complete description of all items included in the service contract.
- .9 "As-built" Drawings and Specifications:** These will be produced by the Designer from the project record documents maintained on the site and kept up-to-date with all changes marked thereon by the Contractor. Accuracy will be verified by the Designer and the PWGSC Commissioning Manager before preparation and after submission by the Designer. They shall be completed in time to be used during pre-start-up inspections.
- .10 Training Plan:** This will be produced by the Designer and approved by the PWGSC Commissioning Manager to meet project-specific requirements. It will include details provided by the Property Manager relating to numbers and prerequisite qualifications and skills of trainees, type of training (i.e. observation, hands-on, classroom), etc. Instructors will include the Designer, Contractor, specialist sub-contractors, equipment suppliers or manufacturers. Duration of training for each system, instruction aids, etc. will depend on complexity and PFM needs. It will also include provisions for long-term ongoing training needs (e.g. video taping), etc. Training will be under the direction of the Designer and monitored by the PWGSC Commissioning Manager.

- .11 **Inventory of spare parts, special tools, maintenance materials:** Inventory will be identified during the design stage by the Designer with input from the PWGSC Commissioning Manager and the Property Manager, based upon consideration of the complexity of the project and immediacy of availability; specified by the Designer; checked by the Contractor immediately upon delivery to ensure each is complete with instructions for use; inventoried, packaged and identified by the Contractor; and stored by the Contractor in facilities to be designated by the PWGSC Project Manager and the PWGSC Commissioning Manager.

**8. Deliverables relating to the commissioning process**

- .1 **Description of pre-commissioning activities** and production of related documentation: For every item, the extent of involvement of the members of the Commissioning Team will be determined (e.g. who reviews, performs, monitors, certifies). This schedule will be prepared by the Designer with input from the PWGSC Commissioning Manager and will include items such as:
  - .1 **In-plant performance operational verification tests.** In-plant tests and results (including reports) may be witnessed and reviewed by PWGSC Commissioning Manager, verified by the PWGSC Design Quality Review Team and certified by the Designer.
  - .2 **Pre-start-up tests:** These will include pressure, static, flushing, cleaning, "bumping", etc. conducted during construction and will be performed by the Contractor and witnessed and certified by the Designer. The completed documentation will be included in the Commissioning Report.
  - .3 **Pre-start-up inspections** conducted by the Designer prior to start-up and rectification of deficiencies, using approved installation check lists. The completed documentation will be included with the Commissioning Report.
  - .4 **Start-up:** This will be by the Contractor, equipment manufacturer, supplier and/or installing specialist sub-contractor under the direction of the Designer. It will also include rectification of all start-up deficiencies by the Contractor to the satisfaction of the Designer and PWGSC Commissioning Manager.
  - .5 **TAB and performance verification** will be performed by the approved Commissioning Agencies, repeated where necessary until results are acceptable to the Designer. Procedures may have to be modified to suit project requirements. Reported results will be witnessed and certified by the Designer using approved PI and PV forms. The completed Commissioning Reports will be approved by the Designer and provided to the PWGSC Commissioning Manager who reserves the right to verify up to [30]% of all reported results. Any failure of randomly selected item shall result in the rejection of the TAB report or the report of system startup and testing.
- .2 **Schedule of commissioning of integrated systems** and production of related documentation will be prepared conjointly by the Designer and the PWGSC Commissioning Manager. It will also identify integrated systems to be commissioned over and above those listed herein:
  - Fire alarm systems
  - Fire pumps and controllers

- Voice communications systems
- Emergency power generator
- Transfer switch and controllers
- Emergency lighting systems
- Life safety systems identified above
- Smoke control systems
- Environmental space condition and IAQ

Commissioning will be performed by the Contractor or specified Commissioning Agencies, using procedures developed by the Designer and approved by the PWGSC Commissioning Manager. They will be witnessed by, and results certified by, the Designer. Reported results will be witnessed and certified by the Designer using approved PV forms. Upon satisfactory completion, the Commissioning Agency performing the tests will prepare the required Commissioning Report which will be certified by the Designer and forwarded to the PWGSC Commissioning Manager who reserves the right to verify a percentage of all reported results at no cost to the contract.

- .3 Identification:** The PWGSC Commissioning Manager, in cooperation with the Property Manager, will establish an identification system for all systems and equipment which will reflect final MMS (Maintenance Management System) identification requirements. This will be reflected in the identification system used in the working documents by the Designer. During commissioning and before hand-over and acceptance, the Designer, Contractor, Property Manager and PWGSC Commissioning Manager will cooperate to complete inventory data sheets and provide assistance to PWGSC forces in the full implementation of the MMS identification system.
- .4 Commissioning specifications:** Commissioning specifications will be developed and submitted at the same time as the Design Development Report. Final versions will be prepared by the Designer during the working document stage and inserted into the project specifications. PWGSC generic commissioning specifications will be provided and will be edited by the Designer so as to become project- specific. They may have to be supplemented by project-specific commissioning specifications prepared by the Designer, reviewed by the PWGSC Project Manager and approved by the PWGSC Commissioning Manager. They will also include samples of PI and PV Report forms.
- .5 Installation Start-up Check Lists:** These are required to inform the PWGSC Commissioning Manager of those systems which are ready for commissioning. A generic list is provided by the PWGSC Commissioning Manager to the Designer, who will tailor them to meet the requirements of the project.. Where these are not available, they will be developed by the Designer and approved by the PWGSC Commissioning Manager.
- .6 Product Information (PI) report forms:** All product information relating to equipment and components supplied and installed on this project will be reported on approved PI report forms similar to the samples attached to the commissioning specifications. Some PI report forms already exist. Others will be prepared by the Designer, reviewed by the discipline specialists and approved by the PWGSC Commissioning Manager no later than [10] weeks after approval of shop drawings for the equipment concerned. Instructions for use will be included in the commissioning specifications. All completed PI report forms will be certified by the Designer. After review and verification by the PWGSC Commissioning Manager, these report forms will be included in the Building Management Manual.
- .7 Performance Verification (PV) report forms:** All results of tests and commissioning will be entered on approved PV report forms similar to the samples attached to the commissioning

specifications. Some PV report forms already exist. Others will be prepared by the Designer, reviewed by the discipline specialists and approved by the PWGSC Commissioning Manager no later than [10] weeks after approval of shop drawings for the equipment concerned. Instructions for use will be included in the commissioning specifications. All completed PV report forms will be certified by the Designer. After review and verification by the PWGSC Commissioning Manager, these report forms will be included in the relevant Commissioning Reports.

- .8 Commissioning Reports:** The completed PV report forms will be included in properly formatted Commissioning Reports. Before any reports are accepted, all reported results will be subject to verification by the PWGSC Commissioning Manager.
- .9 Activities during the Warranty Period:** While all commissioning activities must be completed before the issuance of the Interim Certificate, it is anticipated that certain commissioning activities will be necessary during the Warranty Period, including:
  - fine tuning of environmental control systems.
  - adjustment of ventilation rates to promote good indoor air quality and reduce the deleterious effects of VOCs generated by off-gassing from construction materials and furnishings, etc..
  - full-scale emergency evacuation exercises.
- .10 Tests to be performed by the Client:** Will be identified at a later stage in the project development.

## **9. Deliverables relating to the administration of commissioning**

Operating effectiveness of seasonal-sensitive equipment and systems will be significantly affected by changes in temperature, wind speed, humidity and barometric pressure. These variations must be identified during design development.. As detailed design develops, the Commissioning Plan will be revised to include provisions for testing all parameters to the full range of operating conditions and to check responses of all such equipment and systems under all conditions. This is required because the operation of all systems are of paramount importance to health, safety, comfort and welfare of occupants and users.

The completion of the renovations to the existing laboratory facilities within the stipulated time frame is essential to the continuance of Client's operations with minimum interruption.

Since access into secure or sensitive areas will be very difficult after take-over, it is necessary to complete commissioning of occupancy-, weather- and seasonal-sensitive equipment and systems in these areas before the building is occupied. Include 6 months in the completion schedule for verification of performance in opposite seasons and weather conditions.

Detailed requirements relating to the timing of the various commissioning activities relative to the commissioning of other systems will be included in the commissioning specifications.

- .1 Commissioning Schedules:** Commissioning will be organized so that there will be no delays in the review and approvals process. The required milestones in the review, approval and commissioning process will be included in the commissioning specifications.
- .2 Commissioning activities scheduling:** A detailed critical path schedule will be prepared by the Commissioning Agent and submitted to the Designer, PWGSC Commissioning Manager and PWGSC Project Manager for review and approval at the same time as the Construction

and Completion Schedule. After approval, it will be incorporated into the Contractor's Construction and Completion Schedule. The Designer, Commissioning Agent, Contractor and PWGSC Commissioning Manager will monitor progress of commissioning against this schedule.

A separate detailed schedule in day-by-day format will be provided by the Commissioning Agent for commissioning of all systems and equipment. This schedule will include a detailed training schedule so as to demonstrate that there will be no conflicts with testing.

**10. Payments for commissioning**

This will be developed as detailed design progresses.

**11. Commissioning process**

**.1 General:** The Contractor shall perform the role of Commissioning Agent. This includes the responsibility for managing the commissioning process including monitoring, training, warranties, etc. The Project Commissioning Team and the Designer will be involved in the process, during their regular reviews, comment on the acceptability of the installations as they are installed, and in particular, witnessing tests of completed systems. The Commissioning Agent is not empowered to determine acceptability of installations. Contractor testing remains the responsibility of the individual sub-trades. However, tests will be witnessed by the Commissioning Agent and, maybe, the Designee. Acceptance of equipment and or systems lies solely with the parties normally granted this authority within the contract.

As defined in the specifications, there are a number of phases to commissioning - documentation, installation, testing and verification of the installed equipment and systems. Static, or pre-start, tests are defined for all equipment. These include duct and pipe pressure test and "megger" testing. Sign-off of the equipment by way of pre-start check sheets is outlined in the specifications. Once individual pieces of equipment or systems have been checked for conformance, start-up will be able to commence.

**.2 Systems to be tested as required by codes:** Where testing is required as part of a regulatory process and where commissioning procedures are fully developed and are appropriate to the project, the PWGSC Commissioning Manager shall ensure that all tests as required by such codes are performed. The PWGSC Commissioning Manager will witness these tests as part of the Quality Assurance role.

**.3 Systems to be commissioned:**

**.1 Architectural:**

**.1 Exterior walls:** Thermographic surveys will be conducted to ensure appropriate level of tightness after the exterior envelope has been completed, the permanent HVAC systems are able to provide appropriate negative or positive pressure, a temperature of at least 20°C can be maintained between inside and outside and the wind speed is less than 10 kph.

**.2 Mechanical**

- .1 HVAC System Testing:** It is envisaged that each piece of HVAC equipment will be initially started up, "bumped", in their "stand-alone" mode, i.e. without mechanical control and fire alarm interfaces being complete. During this period, pre-start checks will be completed and the relevant documentation completed. In the case of hydronic systems, after the pumps have been bumped and the pre-start checks completed, the cleaning process can commence. Items covered at this stage will be those which might have a detrimental effect on the operation of the particular item of equipment, such as noise and vibration, it is realized that the system balancing can have an effect on some parameters. Once individual pieces of equipment have been started up, the systems will be checked out in parallel with the control systems. System documentation will be completed by the Commissioning Agent before verification or training begins.
- .2 Plumbing Systems:** Will be started up and commissioned in a manner similar to that described for HVAC systems. The majority of the equipment will be started up in the stand-alone mode, automatic operation will be checked on a system-by-system basis in parallel with the control systems. System documentation will be completed by the Commissioning Agent and submitted for review before verification or training begins.
- .3 Controls:** Testing and commissioning is specified in the specifications, and the acceptance of the control system is well defined. It is envisaged that the contractor testing i.e. point-by-point testing will be performed in parallel with contractor start up. A complete point-by-point verification will be done as part of system verification and will be witnessed by the Designer and PWGSC Commissioning Controls Specialist. The PWGSC Commissioning Manager may elect to participate. Demonstration of the controls systems will be witnessed by both the EMCS Commissioning Agent and the Contractor's Commissioning Agent prior to the thirty day Final Acceptance test. The final Commissioning is considered to be performed during these two stages and the only additional testing required at the end of the "Final Operational Test" would be the off seasonal test. System documentation will be completed by the Commissioning Agent and submitted for review before verification or training begins.
- .4 Fume Hood and Bio-Safety Cabinets:** All fume hoods and bio-safety cabinets are to be performance tested as specified and in

accordance with T.B 5. 1 (Guideline for testing fume cabinets). Testing to be done by TAB Contractor as part of the overall balancing of the building and systems. Certification of all the cabinets is to be performed by a qualified, recognized, and independent testing authority after final balancing of the air systems. No integrated system testing should be performed until the cabinets have been certified.

### **.3 Electrical**

**.1 Distribution:** Testing and commissioning of the main distribution system is defined within the specifications, requiring an independent testing company to perform a series of pre-energisation and post-energisation tests. Test reports are to be submitted for review before verification of system takes place. Contractor testing apart from this is restricted to "megger" testing of feeders.

**.2 Low Voltage Systems:** These systems, including Communication Systems, and low voltage lighting controls, will be checked out in accordance with the contract documents. Designer to witness system test.

**.3 Alternate Power Systems:** Emergency lighting level outlined in the specification will be initially checked by switching off normal power fights and checking coverage. Transfer switches will be tested by simulating a loss of power. Power availability will be checked at all required equipment requiring emergency power (e.g.. Lights).

**.4 Elevators and Fans etc.:** Designer to witness all systems test.

### **.4 Life Safety Systems:**

**.1 Sprinkler / Standpipe:** Wet and Dry pipe station and sprinkler flow testing will be performed as part of the Fire Alarm System ULC 537 and 536 checks. Designer and Commissioning Agent to witness all tests.

**.5 Fire Alarm Systems:** Fire Alarm System cannot be fully verified until all aspects of the life safety and security are completed. Contractor testing will include a complete verification in accordance with ULC-CAN-SS37-M90. Once the commissioning Agent has submitted a certification report all devices and zones will be demonstrated as to ULC 536. Designer and PWGSC Commissioning Manager to witness all tests.



- .6 Designer's commissioning verification:** The Designer is to witness all system and integrated system tests.
- .7 Documentation:**
- .1 Building Management Manual will be compiled as separate manuals in English and French. The Designer will review and accept manuals.
  - .2 Record drawings will be provided for the Designer to produce "As Built" drawings. These drawings will comprise a combination of marked up contracts print information and updated contractor working drawings.
  - .3 Spare parts and maintenance materials: A comprehensive list of all spare parts and maintenance material provided under the contract is to be provided. This will become more detailed as recommended parts/tools are identified by the various manufacturers.
- .8 Training:** A comprehensive training plan will be provided by the Commissioning Agent to the operations staff in the final stages of commissioning. Specific requirements are to be included in the specification.
- .9 Warranty/Service Contracts:** A comprehensive list of all warranties and service contracts will be provided by the Contractor. This list will include standard one year warranties and any non standard warranties.. Information on service contracts will provide a complete description of all items included in the contract.
- .10 Commissioning Schedule:** A critical path Commissioning Schedule to be provided by the Commissioning Agent within three (3) months after award of contract and incorporated in the main construction schedule. It will monitor progress of installation and the sequence of testing, commissioning, documentation, training. A separate detailed schedule in day by day format to be provided by the Commissioning Agent for commissioning of all equipment and systems. Training should be indicated on this schedule to ensure that that training does not conflict with testing.

## **12. Training Plan**

- .1 General:** The following is the preliminary Training Plan and will be developed in greater detail as design progresses and as the working documents are developed. The commissioning schedule will indicate in detail how training will be implemented, the duration of each training session, the trainers, trainees, etc.

**.2 Development of the Training Plan:** The Training Plan shall be complete [within 3 months after award of Contract] [before construction contract is 50% complete].

**.3 Responsibilities:** The Designer will be responsible for training and will monitor all training activities including:

1. Preparation of agenda and outlines
2. Videotaping of all sessions

The Contractor will be responsible for implementation of training activities, quality of instruction and training materials and for coordination among the instructors.

**.4 Instructors:** Instructors and trainers will include the Designer, Contractor, factory-trained and certified equipment suppliers and manufacturers, factory-trained and certified maintenance specialist personnel and the service contractors holding service contracts for the following:

- EMCS including fume hood and BSC controls
- fire alarm systems and emergency systems
- security systems
- lighting control systems
- elevators

and any other service contracts that may be implemented during this project.

**.5 Trainees:** These will include the Property Manager, building operators, maintenance staff, security staff, technical specialists as necessary and facility occupants as necessary. The following is a list of O&M personnel, property management staff and others requiring requisite training, and the PWGSC Commissioning Manager will coordinate their attendance at agreed-upon times.

	Number
Facility Property Manager (already in place)	1
Operating staff: Building operators (already in place)	7-8
Maintenance staff: Plouffe Park shops	??
Building Maintenance (already in place)	7-8
Service contractors (e.g. cleaning)	??
Security staff: (already in place):	7-24

**.6 Prerequisite skills and qualifications:** To be identified.

**.7 Scheduling of training:** Training sessions relating to the design philosophy are to be given by the Designer and shall be presented within three months after award of contract. This will permit all involved in the construction and future operation of this facility to become familiar with all aspects of the design philosophy. If the O&M personnel have not been identified or are not available at this time, these sessions will be repeated during the Contractor-led training sessions. All training will be completed prior to issuance of the Interim Certificate.

**.8 Details of training:** Training will meet all identified qualification requirements of installed equipment and systems. Training will include:

1. all aspects of operation under all normal, emergency and "what-if" modes, over the full range of operating ranges.
2. detailed maintenance, troubleshooting, regular, preventive and emergency maintenance.
3. training will consist of the following elements, to be completed, with demonstration of completeness, before date of acceptance:

- .1 random on-site familiarization and observations during construction, installation, layout of equipment, systems and components, start-up and testing of the work, access to approved shop drawings, equipment operating and maintenance data. On- site observations will include still-photo records as deemed necessary by the O&M personnel – particularly of concealed elements.
  - .2 hands-on instruction relating to start-up; shut-down; emergency procedures; features of controls; monitoring; servicing; maintenance; performance verification and commissioning; reasons for, results of and implications on associated systems of adjustment of set points of control, limit and safety devices; interaction among systems during integrated operation; and troubleshooting diagnostics. Other elements will include system operating sequences, step-by-step directions for operation of valves, dampers, switches, adjustment of control settings and other specialized training relating to installed systems. Duration will be as specified in the commissioning specifications.
  - .3 formal classroom sessions relating to functional and operational requirements, system philosophy, limitations of each system, and operation and use of Building Management Manual. Duration of these sessions will be as specified in the commissioning specifications, using space to be identified.
  - 4. training sessions on design philosophy, organized around the Building Management Manual and will include:
    - 1. overview of how each system is intended to operate
    - 2. description of design parameters and operating requirements
    - 3. description of operating strategies
    - 4. information to assist in troubleshooting system operating problems
- .9 Training materials:** Training materials will be in a form permitting future training procedures to be in the same degree of detail and will include at least the following:
- .1 "As-built" contract documents
  - .2 Building Management Manual
  - .3 TAB and PV Reports
  - .4 transparencies for overhead projectors and 35 mm slides
  - .5 manufacturers' training videos (after prior screening for suitability)

.6 equipment models

The number of hours for these training sessions must be identified – by equipment, systems, etc.

- .10 Videotaping:** Hands-on and classroom sessions will be videotaped for future reference and retraining but will be held only after all systems have been fully commissioned. Production will be of professional quality and organized into several short modules to permit incorporation of changes. Videotaping shall be in VHS format.
- .11 Standard of training:** Training will be in sufficient detail and of sufficient duration to ensure:
  - .1. safe, reliable, cost-effective, energy-efficient operation of all systems in normal and emergency modes and under all conditions,
  - .2 effective ongoing inspection, measurements of system performance,
  - .3 proper preventive maintenance diagnosis, troubleshooting,
  - .4 ability to update documentation,
  - .5 ability to operate equipment and systems under emergency conditions until appropriate qualified assistance arrives.
- .12 Limitations:** Long-term ongoing training will not be included. However, the training courses and training materials will permit further ongoing training as well as training of new personnel.
- .13 Demonstrations:** Training will include demonstrations by the trained personnel to show their confidence in, and depth of understanding of, all installed systems and equipment and to demonstrate completeness of their training.
- .14 Manufacturers' video-based training:** Video will be used as training tool after Engineer's review of videos and written approval at least three months prior to static completion. To be included in Construction and Completion Schedule.

**END OF SAMPLE COMMISSIONING PLAN**



**Sample Standard Operating Procedures Manual**

**2.11. VENTILATION SYSTEMS**

**DELETE NON-APPLICABLE SYSTEMS AS REQUIRED**

(INCLUDES ALL SYSTEMS THAT CONDITION AND DELIVER INDOOR AIR)

**30-050-\*\*\* AIR HANDLING UNIT**  
**30-030-\*\*\*: SPLIT A/C UNIT**



INVENTORY MENU		
MMS. NO.	TYPE/GENERAL INFORMATION / REFERENCE	PAGE

**⚠ CAUTION ⚠**

**IMPORTANT →** All control set points and limits outlined in **Table 1** are to be set, calibrated and maintained only by those persons authorized to do so according to the “**OPERATING ENGINEERS ACT**” (1979 or more recent) guidelines and/or service contracts.

**VERY IMPORTANT →** Should actual set points or limits differ from what is outlined in Table 1, or from what may be outlined throughout the text of this manual, ***it must be brought to the attention of the building operations supervisor immediately for corrective action by authorized personnel.***

**SAFETY SHUTDOWNS →** Should the system shut down due to tripping of a safety/protection device (e.g. High condenser pressure, motor overload, etc.) verify the cause of the activation of the interlock and, if necessary, request the services of the appropriate personnel to inspect and/or repair accordingly before restarting the system.

**IMPORTANT →** For your own safety, follow only **PWGSC** established in-house procedures when resetting or restarting the system or any of its components following a safety shutdown.

**PROLONGED SHUTDOWNS →** Whenever it is necessary to shut down the system for maintenance, repair, or for the season, do so by opening and locking out the main disconnect at the unit before performing any work on the system.

**IMPORTANT →** Ensure that all equipment lockout and safety practices (including **confined space entry** procedures where applicable) are observed.

SYSTEM	
<b>VENTILATION</b>	
TYPE:	<i>variable air volume</i>
MMS. NO.:	30-050-AHU001
LOCATION	
Room 400	
AREA SERVED	
Building West Wing	



PLENUM TYPE	MANUFACTURER	MODEL	SERIAL NO.
Galvanized Steel	McQuay	LSL 150	97K054100
SUPPLY AIR TEMPERATURE	SUPPLY AIR FAN CAPACITY	COMPRESSOR CAPACITY	
12-18	27,945 CFM	70 tons	
COILS (HEATING/COOLING)		FRESH AIR MAKE-UP VOLUME	
One (1) heating Coil One (1) cooling coil			
BURNER CAPACITY: →	N/A		
HUMIDIFICATION: →	Nortec Steam humidifier		
FILTERS: →	PREFILTER:	20-24x24x2 mini pleat	
	FILTER:	12-24x24x4 mini pleat	
AUXILIARIES: →	NA		
DRIVE CONTROL: →	<i>e.g. variable speed frequency controller</i>		
CONTROL: →	<input type="checkbox"/> PNEUMATIC	<input type="checkbox"/> ELECTRIC	<input type="checkbox"/> COMPUTER
SOURCE OF POWER: →	<i>e.g. starter/disconnect switch/stop/stop-start device/mcc</i>		

EQUIPMENT/COMPONENTS	PAGE
FANS	
PUMPS	
HUMIDIFIERS	
GAS DETECTORS	
CONDENSERS	

### OPERATION CRITERIA

#### SCHEDULE OF OPERATION

Units normally operate full time throughout the year, with scheduled downtime for maintenance, and as required for unscheduled repairs.

#### OPERATION/CONTROL - NORMAL OPERATING MODE

The following safety interlocks are an integral part of the units operation and control. Safety interlocks listed in **Tables 1 and 3** and, highlighted with an asterisk (\*), will prevent the unit from functioning if their operating parameters are not satisfied. All safety interlocks listed in **Table 1** are to be maintained within the set point parameters outlined in the table.

**TABLE 1. CONTROLS / SET POINTS / INTERLOCKS**

	SETPOINT	CUT-IN	CUT-OUT	RESET (MANUAL/AUTO)
* FREEZE LIMIT (FREEZE-STAT)	5 °C	4.5°C	5.5°C	MANUAL
*LOW OUTSIDE AIR TEMPERATURE LIMIT	-	-	-	-
**HEATING LOOP FLOW SWITCH	-	-	-	-
**OUTSIDE AIR TEMPERATURE	-	-	-	-
* BLOWER FAN INTERLOCK (STARTER)	N/A	-	-	MANUAL
* DAMPER ENDSWITCH (INTERLOCK)	-	-	-	-
* HEATING PUMP FLOW SWITCH	-	-	-	-
* HIGH/LOW PRESSURE GAS CUT-OUT SWITCH	-	-	-	-

**IMPORTANT** → \*\* If outside air temperature is below \*\*°C/\*\*°F, a heating loop failure (flow switch) will cause the unit to shut down)

**TABLE 2: THE FOLLOWING NORMAL OPERATING CONDITIONS SHOULD BE OBSERVED**

SPACE (ROOM) AIR TEMPERATURE	21.0° - 23.0°C
SPA RETURN AIR HUMIDITY	35% RH
SUPPLY AIR HUMIDITY	< 80% RH
RETURN AIR TEMPERATURE	21.0° - 23.0°C
MIXED AIR TEMPERATURE	10.0° - 17.0°C
SUPPLY AIR TEMPERATURE	12.0° - 18.0°C
SUPPLY STATIC PRESSURE	199 PASCAL

**TABLE 3: FIRE SAFETY INTERLOCKS**

FIRE ALARM	RESET (MANUAL/AUTO)
SPA * FIRE ALARM SYSTEM INTERLOCK	MANUAL
* SUPPLY AND RETURN AIR SMOKE DETECTORS	AUTO



**CONTROL DESCRIPTION - NORMAL OPERATING MODE**

**AIR HANDLING UNIT 1** is a variable air volume system normally operated and controlled automatically by the Energy Management Control System (EMCS). This system runs based on the following time schedule:

Sunday	Monday	Tuesday	Wednesday	Thursday	Friday	Saturday
Off	4:30am On	5:00am On	5:00am On	5:00am On	5:00am On	Off
	6:00pm Off	6:00pm Off	6:00pm Off	6:00pm Off	6:00pm Off	

The unit may also be started by an optimization sequence calculated by the EMCS based on outdoor air temperature and the reference room space temperature. In this mode of operation, the dampers remain in full recirculation position.

The discharge air temperature is maintained between 13° and 17°C based on the following reset schedule:

Outdoor Air Temperature	Discharge Air Temperature Setpoint
-20°C	18°C
13°C	12°C

When the outdoor air temperature is below 8°C, the discharge air temperature is maintained by modulating the electric heating coil. A minimum fresh air of 27% at minimum supply air flow and 11% at maximum airflow is calculated by using the outdoor air temperature and return air temperature. The mixing damper modulate to maintain a mixed air temperature setpoint resulting from the previous fresh air calculation.

When the outdoor air temperature is above 8°C but below 12 °C, the discharge air temperature is maintained by modulating the mixing dampers and enabling two (2) of the four (4) stages of cooling in sequence. A delay of six minutes is set between each cooling stage.

When the outdoor air temperature is above 12°C, the discharge air temperature is maintained by sequencing the four (4) stages of cooling. The mixing dampers are locked to an operator adjustable minimum position of 15%. The two last stages of cooling are not permitted to start until the outdoor air temperature is greater than 18°C.

A constant static pressure is maintained in the ducts to ensure an adequate quantity of air is available in all areas at all times. On startup, the supply fan variable speed drive modulates to maintain a static pressure setpoint of 0.8” W.C. in the duct. and the return fan drive tracks the supply fan volume (total of VAV primary flow readings) and is set to deliver at a flow rate of 1400 l/s less than the supply fan.

The return air humidity is maintained at 35%rh by modulating the humidifier in the supply duct. A supply air humidity high limit has been incorporated to override the humidifier control if the supply air humidity exceeds 80%. The humidifier is only permitted to start after a proof of supply fan operation and a ten (10) minute delay.

The return fan is interlocked with the supply fan. A freeze detector will alarm and shut down the fan units. Software acknowledgment of a failed unit is required before they may restart via the EMCS control.

**OPERATIONAL PROCEDURES - START-UP**

Following a system shutdown, the following procedures must be taken prior to starting the air handling system. In fact, these procedures must be observed and followed at all times to maintain normal building operations. These procedures are applicable when the system is started automatically.

**PREPARATION**

1. Ensure all air filters are properly installed and acceptably clean. Check for damage to filters (i.e. rips, tears or holes in filter media - replace as required).
2. Verify all cabinet access and clean-out doors are fully closed and secured.
3. Verify fan belt drives are properly tensioned and not obstructed by any debris.
4. Verify water supply valve to the humidifier is *fully open* and power supply is on.
5. Verify power to supply and return fan variable frequency drives are on. Depress reset buttons on each of the respective starters to ensure clearance of any control interlocks.

**THE UNIT MAY NOW BE STARTED**

1. Start the unit by placing the Hand-Automatic selector switch on the variable frequency drives for the supply and return fans in the "Auto" position.
2. When the system gets a start command from the EMCS, the unit will start.
3. Should the fan fail to start, verify that controls interlocks are satisfied as outlined in the "Operation Criteria" - Table 1 (on page M-5) for this system and that all procedures previously outlined have been taken.
4. After unit operation has stabilized, verify normal operating conditions for this system as outlined in Table 2 (on page M-5). Ensure all system components are operational and check for any unusual vibration or noise.



**CONTROL DESCRIPTION - EMERGENCY OPERATING MODE**

In the event of damage to the controller or the loss of power to the controller, following procedures should be used. Power must be available to fans, and cooling system (during cooling season).

**Note:** If the unit must be run in an emergency situation, it should not be left unsupervised for an extended amount of time.

**OPERATIONAL PROCEDURES - START-UP**

Following a system shutdown, the following procedures must be taken prior to starting the air handling system. These procedures are applicable when the system is started manually.

**PREPARATION**

The following equipment should be available before starting the following procedure:

- 1- Portable temperature probe. (electronic or mechanical thermometer)
- 2- Magnehelic pressure gauge or incline manometer. (minimum range or 0 to 1.5"W.C.)
- 3- Portable relative humidity probe.
- 4- Variable DC Voltage power source. (Loop Calibrator with a minimum range of 0 to 10 Vdc)
- 5- Variable frequency drive **Operator's Manual** for supply and return fan.

**Note:** Item 3 and 4 may be optional if humidifiers are not required to operate.

1. Ensure all air filters are properly installed and acceptably clean. Check for damage to filters (i.e. rips, tears or holes in filter media - replace as required).
2. Verify all cabinet access and clean-out doors are fully closed and secured.
3. Verify fan belt drives are properly tensioned and not obstructed by any debris.
4. Verify water supply valve to the humidifier is *fully open* and power supply is on.
5. Verify power to supply and return fan variable frequency drives are on. Depress reset buttons on each of the respective starters to ensure clearance of any control interlocks.
6. Remove power to all damper actuator needed to be operated manually.
7. Remove static pressure sensor tubing from duct and replace with portable pressure gauge (magnehelic or incline manometer) tubing.
8. Remove the supply air temperature sensor from the supply duct and insert the portable temperature probe.
9. Remove return air temperature sensor from the return duct.
10. Remove the humidifier control wire from the controllers terminals 35 (-) and 36 (+) and attach the lead of the variable DC Voltage power source to these wires ensuring proper polarity.
11. Read carefully the instructions for manually operating the fans variable frequency drive.

**THE UNIT MAY NOW BE STARTED**

1. Start the supply and return fan using the keypad on the variable frequency drives. Ramp the speed of the supply fan gradually while monitoring the supply duct static pressure until desired value outlined in Table 2 (on page M-5) is reached. Ramp return fan speed equally with supply fan speed. When static pressure has stabilized, verify that building pressure is adequate (exterior doors operate normally). If doors tend to stay open, increase return fan speed. If doors tend to be difficult to open decrease return fan speed.
2. Should the fan fail to start, verify that controls interlocks are satisfied as outlined in the "Operation Criteria" - Table 3 (on page M-5) for this system.
3. Open fresh air and exhaust air damper between 15 and 20% and open mixed air damper between 85 and 80% using the crank provide with the actuator motors. This will allow minimal fresh air into the building. Monitor supply air temperature and adjust dampers to maintain temperature outlined in Table 2 (on page M-5).

**Warning! Actuators may be damaged if power is not removed before manually positioning the actuator with the crank.**

4. During the heating season, the heating coil will not be used to maintain supply air temperature. The heating coil circuit requires a 24 Vac modulated timed pulse to modulate the power to the heating coil. It would require constant attention from the operator just to maintain the supply air temperature.
5. During the cooling season, monitor the return air temperature using the thermometer and cycle the cooling stage on and off to maintain the return air temperature within the limits outlined in Table 2 (on page M-5). The cooling stages may be energized by placing a jumper across the normally open contacts of the omron relay located in the condenser unit control panel. Do not start the second compressor if the outdoor air temperature is below 18°C.
6. If humidification is required, set the output of the variable DC Voltage power source to 5 volts. Monitor the return and supply air humidity periodically using the portable relative humidity probe. Make voltage adjustments to maintain the readings at values listed Table 2 (on page M-5).
7. After unit operation has stabilized, continuously verify normal operating conditions for this system. Ensure all system components are operational and check for any unusual vibration or noise.
8. When the problem has been rectified, restore the unit to its original state.



**CONTROL DESCRIPTION - MANUAL *OPERATING MODE***

See Emergency Operating Mode.

**OPERATIONAL PROCEDURES - START-UP**

**PREPARATION**

**THE UNIT MAY NOW BE STARTED**

HVAC SYSTEMS CHECKLIST	FREQUENCY
<ul style="list-style-type: none"> <li>▪ CHECK AND RECORD TEMPERATURE OF SUPPLY AIR, RETURN AIR, MIXED AIR AND SPACE(S) SERVED AS APPLICABLE</li> </ul>	<b>DAILY</b>
<ul style="list-style-type: none"> <li>▪ VISUALLY CHECK CONDITION OF PRE-FILTER/MAIN FILTER AND REPLACE AS REQUIRED</li> <li>▪ CHECK AND RECORD STATIC PRESSURE DIFFERENTIAL ACROSS FILTER</li> <li>▪ VISUALLY CHECK DAMPER POSITIONS AND LINKAGES</li> <li>▪ CHECK OPERATION OF FANS FOR VIBRATION AND PROPER BELT TENSION</li> </ul>	<b>WEEKLY</b>
<ul style="list-style-type: none"> <li>▪ CHECK VARIMARK OR INLET VANES FOR PROPER OPERATION</li> <li>▪ <b>IMPORTANT →</b> VISUALLY CHECK HEATING, COOLING AND PREHEAT COIL AND ASSOCIATED PIPING AND VALVES FOR WATER LEAKS</li> <li>▪ CHECK AND RECORD HEATING, COOLING AND PREHEAT COILS, SUPPLY AND RETURN TEMPERATURE AND PRESSURE</li> <li>▪ <b>IMPORTANT →</b> CHECK FOR NORMAL OPERATION OF DEHUMIDIFICATION AND/OR STEAM HUMIDIFICATION SYSTEM</li> <li>▪ CHECK FIRE DAMPER LINKAGE AND DAMPER POSITION</li> <li>▪ ENSURE ALL COMPARTMENT DOORS ARE CLOSED AND LATCHED</li> <li>▪ <b>IMPORTANT →</b> VERIFY ALL NATURAL GAS ISOLATION VALVES ARE FULLY OPENED TO GAS-FIRED HEAT EXCHANGERS (IF APPLICABLE)</li> </ul>	<b>DAILY</b>

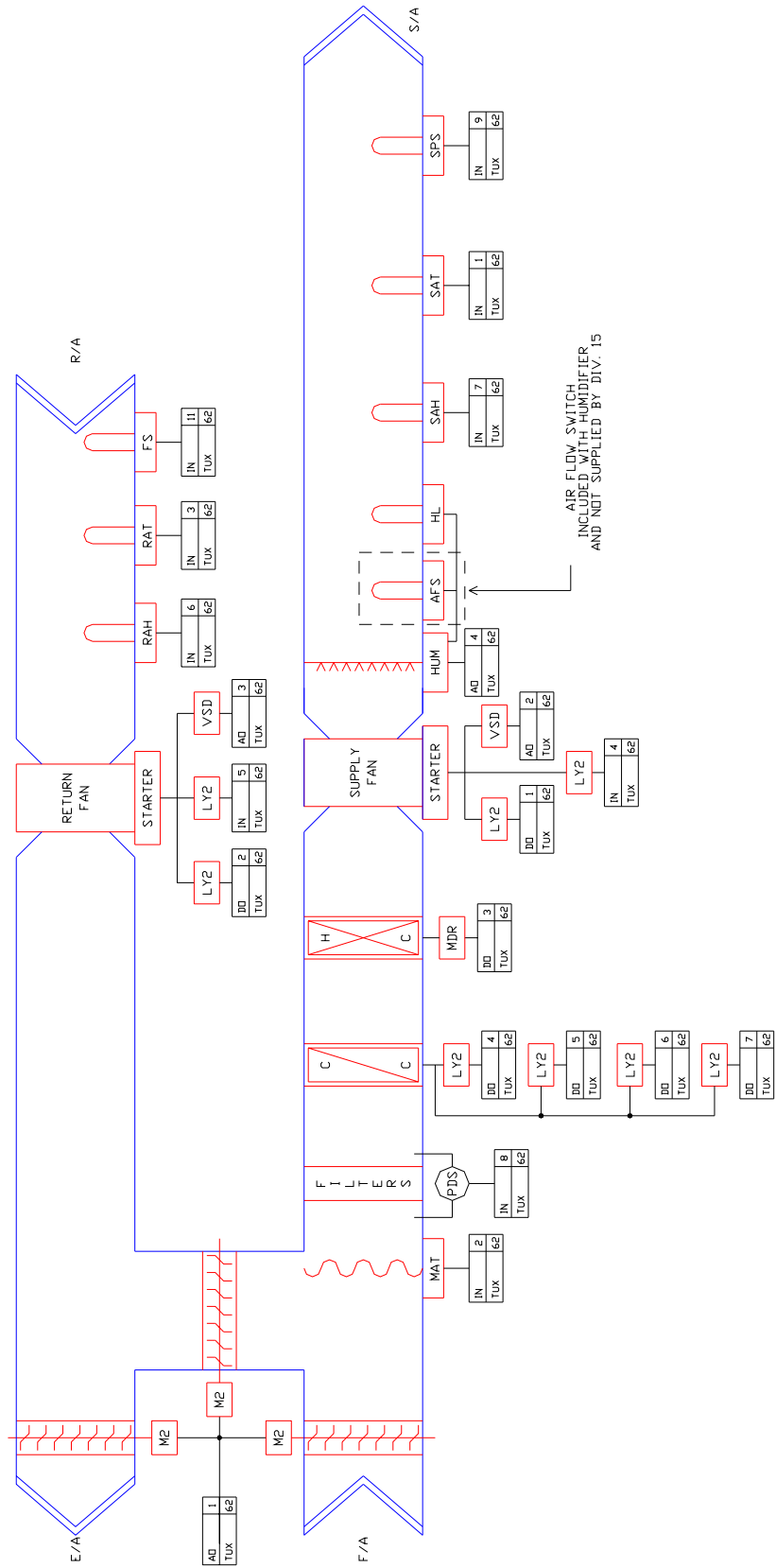

## End of Sample Standard Operating Procedures Manual

## Sample of Training Plan

**NOTE:** *This is a sample (only) of the type of Training Plan which might be used with a project for upgrading, extending, and replacing existing laboratory facilities.*

### 1. General

The following is the Preliminary Training Plan and will be developed in greater detail as design progresses and as the Working Documents are developed.

The commissioning schedule prepared by the Contractor will indicate in detail how training will be implemented, the duration of each training session, the trainers, trainees, etc.

### 2. Development of Training Plan

The Training Plan shall be complete [within 3 months after award of Contract] [before construction contract is 50% complete].

### 3. Responsibilities

The Designer will be responsible for training and will monitor all training activities including:

1. Preparation of agenda and outlines
2. Videotaping of all sessions

The Contractor will be responsible for implementation of training activities, quality of instruction and training materials and for coordination among the instructors.

### 4. Instructors

Instructors and trainers will include the Designer, Contractor, factory-trained and certified equipment suppliers and manufacturers, factory-trained and certified maintenance specialist personnel and the service contractors holding service contracts for the following:

- EMCS
- fire alarm systems
- security systems
- lighting control systems
- elevators

and any service contracts that may be implemented during this project.

### 5. Trainees

These will include the Facility (Property) Manager, building operators, maintenance staff, security staff, technical specialists as necessary and facility occupants as necessary.

The following is a list of O&M personnel, property management staff and others requiring requisite training: the Commissioning Manager will coordinate their attendance at agreed-upon times (typical for Parliamentary Precinct projects):

	Number
Facility Property Manager (already in place)	1
Operating staff: Building operators (already in place)	7-8
Maintenance staff: Plouffe Park shops	??
Building Maintenance (already in place)	7-8
Service contractors (e.g. cleaning)	not known
Security staff (already in place)	

### 6. Prerequisite Skills and Qualifications of trainees



[to be specified \_\_\_\_\_].

**7. Scheduling of training**

Training sessions relating to the design philosophy:

1. These are to be given by the Designer and shall be presented within three months after award of contract. This will permit all involved in the construction and future operation of this facility to become familiar with all aspects of the design philosophy.
2. If the O&M personnel have not been identified or are not available at this time, these sessions will be repeated during the Contractor-led training sessions.

All training will be completed prior to issuance of the Interim Certificate.

**8. Details of training**

Training will meet all identified qualification requirements of installed equipment and systems.

Training will include:

1. All aspects of operation under all normal, emergency and "what-if" modes, over the full range of operating ranges.
2. Detailed maintenance, troubleshooting, regular, preventive and emergency maintenance. Training will consist of the following elements, to be completed, with demonstration of completeness, before date of acceptance:
  1. Random on-site familiarization and observations during construction, installation, layout of equipment, systems and components, start-up and testing of the work, access to approved shop drawings, equipment operating and maintenance data. On-site observations will include still-photo records as deemed necessary by the O&M personnel – particularly of concealed elements.
  2. Hands-on instruction relating to start-up; shut-down; emergency procedures; features of controls; monitoring; servicing; maintenance; performance verification and commissioning; reasons for, results of and implications on associated systems of adjustment of set points of control, limit and safety devices; interaction among systems during integrated operation; and troubleshooting diagnostics. Other elements will include system operating sequences, step-by-step directions for operation of valves, dampers, switches, adjustment of control settings and other specialized training relating to installed systems. Duration will be as specified in the commissioning specifications.
  3. Formal classroom sessions relating to functional and operational requirements, system philosophy, limitations of each system, and operation and use of Building Management Manual. Duration of these sessions will be as specified in the commissioning specifications, using space to be identified.
  4. Location of training to be determined.
  5. Training sessions on design philosophy will include:
    1. overview of how each system is intended to operate
    2. description of design parameters and operating requirements
    3. description of operating strategies
    4. information to assist in troubleshooting system operating problems

**9. Training materials**

Training materials will be in a form permitting future training procedures to be in the same degree of detail and will include at least the following:

1. "As-built" contract documents
2. Building Management Manual
3. TAB and PV Reports
4. Transparencies for overhead projectors and 35 mm slides
5. Manufacturers' training videos (after prior screening for suitability)
6. Equipment models

**10. Videotaping**

Hands-on and classroom sessions will be videotaped for future reference and retraining but will be held only after all systems have been fully commissioned. Production will be of professional quality and organized into several short modules to permit incorporation of changes.

*(Note any requirements for training Owner, Investor or User.)*

**11. Standard of training**

Training will be in sufficient detail and of sufficient duration to ensure:

1. Safe, reliable, cost-effective, energy-efficient operation of all systems in normal and emergency modes and under all conditions
2. Effective ongoing inspection, measurements of system performance
3. Proper preventive maintenance diagnosis, troubleshooting
4. Ability to update documentation
5. Ability to operate equipment and systems under emergency conditions until appropriate qualified assistance arrives

**12. Limitations**

Long-term ongoing training will not be included. However, the training courses and training materials will permit further ongoing training as well as training of new personnel.

**13. Demonstrations**

Training will include demonstrations by the trained personnel to show their confidence in, and depth of understanding of, all installed systems and equipment and to demonstrate completeness of their training.

**14. Manufacturers' video-based training**

Video will be used as training tool after Engineer's review of videos and written approval at least three months prior to static completion. To be included in Construction and Completion Schedule.

**TABLE 1: SUMMARY OF TRAINING ACTIVITIES**

PDS Phase	Training Activity
2 Definition	Training requirements are defined in the Commissioning Brief. To include: - extent, nature and location of training - standards to be achieved
3a Design	Designer identifies training that will be required and obtains from PWGSC a list of O&M personnel to be trained, prerequisites, qualifications, etc. Designer of specialized projects (e.g.. Some special laboratories) may recommend qualifications..
3b Working Documents	1. Training Plan approved.
3d Construction/ Installation	1. Confirm availability, presence of assigned O&M personnel for observation as system installations proceed. 2. Provide site familiarization sessions.
4 Commissioning	2. Provide site familiarization sessions.
5 Operation	1. Evaluate training provided to O&M personnel using, as basis, ability of O&M personnel to: a. adjust systems, in response to complaints, thus rectifying identified faults b. minimize energy consumption by intelligent adjustments and at the same time maximize system efficiency c. investigate and troubleshoot systems to determine source of, and reasons for, faults or failures; take corrective actions. 2. Observe and assess quality of training. 3. Recommend additional training as necessary.

**Sample of Training Activities - Architectural**

<b>ARCHITECTURAL (THIS IS BROAD OUTLINE ONLY)</b>				
<b>This Training Plan forms Part of Section 01815</b>				
<b>Systems and Goals</b>	<b>Instructors</b>	<b>Content (approximately 30% Theory, 70% practical)</b>	<b>Approx. duration</b>	<b>Instruction Materials and Tools</b>
<b>Elevators</b>	Installing Contractor, Manufacturer	Operation and control features, Emergency power, emergency response Interconnection with FA systems (i.e. Fire fighters' features)		
<b>Escalators</b>	Installing Contractor, Equipment Manufacturer			
<b>Waste Management</b> (e.g. garbage collectors, chutes, compactors, shredders, destructors)	Installing Contractor, Authority having jurisdiction	Operation and control features, emergency power, emergency response		Licensing by authority having jurisdiction
Incinerators [with heat recovery]	Installing Contractor, Authority having jurisdiction			
<b>Building Envelope</b> Air/water penetration rate serving building in event of failure of mains analyses Water shedding systems Thermal performance Light transmittance	Installing Contractor, Special Testing Agency			

**Sample of Training Activities - Mechanical**

<b>MECHANICAL (THIS IS BROAD OUTLINE ONLY)</b>				
<b>This Training Plan forms Part of Section 01815</b>				
<b>Systems and Goals</b>	<b>Instructor</b>	<b>Content (approximately 30% Theory, 70% practical)</b>	<b>Approx duration</b>	<b>Instruction Materials and Tools</b>
<b>Design Philosophy</b> 1. General overview of design concepts 2. Awareness of interaction of mechanical systems	Engineer	1. Explanation of mechanical and related electrical systems, their interaction 2. Site visit in early stages of project 3. Classroom sessions during commissioning stage	½ day ½ day	1. Schematics of layouts & controls 2. Installed systems, equipment 3. Design Criteria, Design Intents
<b>HVAC Systems</b> Central ducted supply and return systems Exh. systems: kitchen, LFH, BSC, washrms. Smoke control systems: zone isolation, connections to FA systems Stand-alone HVAC systems 1 To learn details of all systems installed 2. To develop in-depth knowledge of the operation of each system	Installing Contractor, Equipment Manufacturer, EMCS trade	1. Explanation of operational concepts of systems and components including air handling units, fans, filters, coils, VAV boxes, humidification systems, use of economizer cycles and controls 2. Equipment operation and adjustment 3. Review of O&M Manuals 4. Equipment troubleshooting 5. Observation during construction 6. Site visits, classroom sessions	3 days	1. "As-built" HVAC drawings 2. TAB & PV Reports 3. Systems Operations Manual 4. Maintenance Manual 5. Installed systems, equipment 6. Controls Schematics and Reports 7. Demonstrations
<b>Steam or Hydronic Heating Systems</b> 1. Training in equipment start-up, operation, shut-down, prevention of, and re-start after emergency shutdown, operation at optimum efficiencies 2. To prevent breakdowns, limit service calls	Contractor, Equipment Manufacturer	1. Start-up, testing and operation of systems, steam generators for humidifiers, circulating pumps, controls (operating, limit, safety). Annual maintenance, restart after emergency shut-down. 2. Review of O&M Manuals 2. Equipment troubleshooting 3. Site visit, then classroom period for Q&A	2 days	1. Installed equipment 2. Demonstrations 3. "As-built" piping drawings 4. Systems Operations Manual 5. Equipment O&M Manual 6. TAB and PV Reports 7. Controls Schematics, Report s

<b>MECHANICAL (THIS IS BROAD OUTLINE ONLY)</b>				
<b>This Training Plan forms Part of Section 01815</b>				
<b>Systems and Goals</b>	<b>Instructor</b>	<b>Content (approximately 30% Theory, 70% practical)</b>	<b>Approx duration</b>	<b>Instruction Materials and Tools</b>
<b>BAS, EMCS</b> Control systems for mechanical systems Compressed air systems for EMCS. Building control components. System programming. Project-specific controls: (e.g. humidification of special areas, dehumidification of swimming pools, diversified controls: "smart panels" for central and local HVAC systems Debugging software	System Installing Contractor, EMCS sub-trade.	<ol style="list-style-type: none"> <li>1. Explanation of operational concepts of systems and components</li> <li>2. Use of various cycles and controls</li> <li>2. Equipment operation and adjustment</li> <li>3. Review of O&amp;M Manuals</li> <li>4. Equipment and system troubleshooting</li> <li>5. Observation during construction</li> <li>6. Site visits, classroom sessions</li> </ol>	5 days	<ol style="list-style-type: none"> <li>1. "As-built" HVAC and control drawings</li> <li>2. Systems Operations Manual</li> <li>3. Maintenance Manual</li> <li>5. Installed systems, equipment</li> <li>6. Controls Schematics and Reports</li> <li>7. Demonstrations</li> </ol>
<b>Water Analysis and Treatment</b> <ol style="list-style-type: none"> <li>1. Training in O&amp;M of water treatment equipment</li> <li>2. To learn how to maintain specified water quality</li> </ol>	Installing Contractor, Water Treatment Manufacturer	<ol style="list-style-type: none"> <li>1. Description of equipment, systems, chemicals, justification for specified standards, sampling collection and testing techniques, analysis of raw water, treated water</li> <li>2. Review of O&amp;M Manuals.</li> <li>3. Equipment troubleshooting</li> <li>4. Observation during construction</li> <li>5. Classroom sessions</li> </ol>	½ day	<ol style="list-style-type: none"> <li>1. Demonstrations</li> <li>2. Laboratory facilities</li> <li>3. Chemical and bacteriological analyses</li> <li>4. Water treatment O&amp;M Manuals</li> </ol>
<b>Refrigeration Systems</b> Kitchen, servery, laboratory <ol style="list-style-type: none"> <li>1. Training in equipment start-up, operation, shut-down, prevention of, and restart after emergency shut-down</li> <li>2. To learn to operate equipment safely and at optimum efficiencies</li> <li>3. To prevent breakdowns, limit service calls</li> </ol>	Installing Contractor	<ol style="list-style-type: none"> <li>1. Start-up, testing of O&amp;M of required conditions, controls (operating, limit, safety). Annual maintenance, re-start after emergency shut-down</li> <li>2. Review of O&amp;M Manuals</li> <li>5. Equipment troubleshooting</li> <li>6. Observation during installation</li> <li>7. Classroom sessions</li> </ol>	2 days	<ol style="list-style-type: none"> <li>1. Demonstrations</li> <li>2. "As-built" piping drawings</li> <li>3. Systems Operations Manual</li> <li>4. Equipment O&amp;M Manual</li> <li>5. Controls Schematics &amp; Reports</li> <li>6. Commissioning Reports</li> </ol>

<b>MECHANICAL (THIS IS BROAD OUTLINE ONLY)</b> <b>This Training Plan forms Part of Section 01815</b>				
<b>Systems and Goals</b>	<b>Instructor</b>	<b>Content (approximately 30% Theory, 70% practical)</b>	<b>Approx duration</b>	<b>Instruction Materials and Tools</b>
<b>Fire Protection and Suppression Systems</b> Sprinkler systems, standpipe and hose systems Fire pumps, controller, transfer switch. Total flooding systems Local application systems 1. Training in start-up, shut-down, emergency requirements 2. Training in interconnection with HVAC, smoke control systems, Fire Dept. 3. To learn use of voice communications systems, emergency evacuation protocols	Contractor, local Fire Dept.	1. Periodic testing 2. Annual maintenance 3. Review of O&M Manuals 4. Equipment, system troubleshooting 5. Observation during installation 6. Classroom sessions	½ day	1. Demonstrations 2. "As-built" piping drawings 3. Systems Operations Manual 4. Equipment O&M Manual 5. Controls Schematics & Reports 6. Commissioning Reports
<b>Dom. H&amp;CWS Systems</b> 1. Training in O&M 2. Training in Legionella control	Contractor, Equipment Manufacturer	1. Annual maintenance 2. Review of O&M Manuals 3. Equipment, system troubleshooting 4. Observation during installation 5. Classroom sessions	½ day	1. Demonstrations 2. "As-built" piping drawings 3. Systems Operations Manual 4. Equipment Mtce. Manual 5. TAB / PV Reports 6. Controls Schematics, Reports

<b>MECHANICAL (THIS IS BROAD OUTLINE ONLY)</b> <b>This Training Plan forms Part of Section 01815</b>				
<b>Systems and Goals</b>	<b>Instructor</b>	<b>Content (approximately 30% Theory, 70% practical)</b>	<b>Approx duration</b>	<b>Instruction Materials and Tools</b>
<b>Storm Water Management Systems</b> Roof drains, catch basins, flow controls, site storage ponds 1. Training in storm water management	Contractor, Equipment Manufacturer	1. Annual maintenance 2. Review of O&M Manuals 3. Equipment, system troubleshooting 4. Observation during installation 5. Classroom sessions	½ day	1. Demonstrations 2. "As-built" piping drawings 3. Systems Operations Manual 4. Equipment Mtce. Manual 5. Commissioning Reports 6. Controls Schematics, Reports
<b>Laboratory/Medical Services</b> 1. Training in O&M of each system 2. Training in identification of different services, verification of additional connections, outlets, etc. 3. Training in lab. waste treatment systems	Installing Contractor, Equipment Manufacturer, Servicing Contractor	1. O&M 2. Review of O&M Manuals 3. Equipment, system troubleshooting 4. Observation during installation 5. Classroom sessions	2 days (1 day if only few services)	1. Demonstrations 2. Systems Operations Manual 4. Equipment Maintenance Manual 5. Commissioning Reports 6. Controls Schematics, Reports



**Sample of Training Activities - Electrical**

<b>ELECTRICAL (THIS IS BROAD OUTLINE ONLY)</b>				
<b>This Training Plan forms Part of Section 01815</b>				
<b>Goal</b>	<b>Instructor</b>	<b>Content (approximately 30% Theory, 70% practical)</b>	<b>Approx duration</b>	<b>Instruction Materials and Tools</b>
<b>General Overview</b> 1. Overall review of design concepts 2. Awareness of interaction of electrical systems	Engineer	1. Explanation of electrical systems 2. Their interaction with other systems 3. Site visit in early stages of project 4. Classroom sessions during commissioning stage	½ day	1. Schematics of power, 120 volt, low voltage layouts, controls 2. Installed systems, equipment 3. Design Criteria, Design Intents
<b>Incoming Service and High Voltage Distribution</b> 1. To learn details of all systems installed throughout complex and to develop in-depth knowledge of its operation	Engineer, Contractor, Equipment Manufacturer	1. Explanation of operational concepts including transformers, HV switching equipment, controls 2. Equipment operation and adjustment 3. Review of O&M Manuals 4. Equipment troubleshooting 5. Observation during construction 6. Site visits, classroom sessions	1 day	1. "As-built" distribution drawings, schematics, test reports 2. Systems Operations Manual 3. Maintenance Manual 4. Installed systems & equipment 5. Controls Schematics 6. Demonstrations
<b>Low Voltage Systems (including low voltage lighting controls, clocks, fire alarm)</b> 1. Training in equipment start-up, operation, shut-down, transfer to emergency power, re-transfer to normal power, operation at optimum efficiencies 2. To understand system designed to prevent failure, limit service calls	Contractor, Equipment Manufacturer	1. Start-up, testing and operation of all systems and controls (operating, limit, safety) 2. Annual maintenance, restart after emergency failure 3. Review of O&M Manuals. Equipment troubleshooting 4. Observation during construction 5. Site visits, classroom sessions	1 day	1. Installed equipment 2. Demonstrations 3. "As-built" drawings 4. Systems Operations Manual 5. Equip't Maintenance Manuals 6. Controls Schematics, Reports
<b>Telephones, Communications, Signaling Systems</b> 1. To learn telephone link-up with utility				

<b>ELECTRICAL (THIS IS BROAD OUTLINE ONLY)</b> <b>This Training Plan forms Part of Section 01815</b>				
<b>Goal</b>	<b>Instructor</b>	<b>Content (approximately 30% Theory, 70% practical)</b>	<b>Approx duration</b>	<b>Instruction Materials and Tools</b>
<b>Security Systems:</b> CCTV, card control, door position switches 1.				
<b>PA Systems, Intercom.</b> Entertainment, background music, white noise 1.				
<b>Special Systems:</b> (e.g. pocket paging, central dictation, nurse call, division bells, simultaneous translation) 1..				
<b>Lighting Systems:</b> Normal interior, exterior, economy measures 1.				
<b>Emergency Lighting Systems:</b> Exit lighting, battery-powered emergency systems 1.				
<b>Emergency Power Systems</b> 1. Training in O&M of fuel system, diesel engine, generator 2. To be able to maintain specified quality of service	Engineer, Contractor, Equipment Manufacture r, Supplier	1. Description of emergency generating equipment, fuel storage and supply system, special ventilation systems, switch gear, distribution systems 2. Review of O&M Manuals 3. Equipment troubleshooting 4. Observation during construction 5. Site visits, classroom sessions	½ day	1. Demonstrations 2. Systems Operations Manual 3. Maintenance Manual 3. Commissioning Reports
<b>Uninterruptible power systems</b> 1.				
<b>Isolated Power Systems</b> (as for hospital operating rooms) 1.				

<b>ELECTRICAL (THIS IS BROAD OUTLINE ONLY)</b> <b>This Training Plan forms Part of Section 01815</b>				
<b>Goal</b>	<b>Instructor</b>	<b>Content (approximately 30% Theory, 70% practical)</b>	<b>Approx duration</b>	<b>Instruction Materials and Tools</b>
<b>Special/Dedicated Electrical Services to Special Areas</b> 1. Training in equipment start-up, operation, shut-down, prevention of, and restart after emergency failures 2. To be able to operate equipment safely, efficiently, with very high operation level without failure, limit service calls	Engineer, Contractor, Equipment Manufacturer	1. Start-up, testing, operation of equipment, controls (operating, limit, safety) 2. Annual maintenance, restart after emergency failure 3. Review of O&M Manuals 4. Equipment troubleshooting 5. Observation during construction 6. Site visits, classroom sessions	1 day	1. Demonstrations 2. "As-built" drawings 3. Systems Operations Manual 4. Equipment O&M Manual 4. Controls Schematics, Reports 5. Commissioning Reports

**END OF SAMPLE TRAINING PLAN**



## Sample of Installation / Start-up Check List

(Installation / Check Lists are at present being reviewed and revised)

Project: <b>PNE#</b>	Project no/No de projet: <b>P#</b>	Page <b>105</b>
Projet:	<b>Date</b>	
No. on Contract Drawings/French:	MMS Identifier/French	
<b>FILTERS - PRE / FILTRES - PRE</b>		
<b>INSTALLATION CHECKLISTS/LISTES DE VERIFICATION DE L'INSTALLATION</b>		
<b>General:</b> <input type="checkbox"/> "General" sheets, portions as appropriate plus the following:	<b>Général:</b> <input type="checkbox"/> Pages "Général", parties appropriées, plus ce qui suit:	
<b>Construction:</b> <input type="checkbox"/> Media - correct type	<b>Construction:</b> <input type="checkbox"/> Matériel filtrant - de type approprié	
<b>Installation:</b> <input type="checkbox"/> Media in place, clean condition <input type="checkbox"/> Zero leakage around media <input type="checkbox"/> Blank-off plates <input type="checkbox"/> Even velocity profile across filter bank	<b>Installation:</b> <input type="checkbox"/> Matériel filtrant en place, propre <input type="checkbox"/> Aucune fuite autour de matériel filtrant <input type="checkbox"/> Plaques d'obturation <input type="checkbox"/> Profile dvélocité traversant le groupe-filtre	
<b>Casing:</b> <input type="checkbox"/> Accessibility for inspection, replacement <input type="checkbox"/> Access doors or panels (opening out) <input type="checkbox"/> Illumination of interior	<b>Boîtiers:</b> <input type="checkbox"/> Portes ou panneaux d'accès (ouvrant vers l'extérieur) <input type="checkbox"/> Éclairage de l'intérieur	
<b>Appurtenances:</b> <input type="checkbox"/> Filter Gauge - red pointer at point of replacement <input type="checkbox"/> Spare filters for installation prior to acceptance <input type="checkbox"/> Temporary filters for Start-up. Media in place	<b>Dépendances:</b> <input type="checkbox"/> Jauge à filtres <input type="checkbox"/> Filtres de rechange pour installation avant l'acceptation <input type="checkbox"/> Filtres temporaires pour la mise en marche. Matériel filtrant en place	

END OF SAMPLE INSTALLATION / START-UP CHECK LIST



**Sample of MMS input into working documents**

<b>VARIABLE VOLUME DUAL DUCT BOXES</b>									
Box Identifier	MMS identifier	Size	Air flow rate		Reheat (watts)	No of rows	Heating coil		Notes
			Max	Min			(US GPM)	Elec (kW)	
VVDD-02-0	30-466-01	5	94	100%					
VVDD-04-0	30-466-02	5	90	100%					
VVDD-05-0	20-466-03	5	70	100%					
VVDD-13-0	30-466-04	6	125	100%					
VVDD-01-1	30-466-05	5	85	100%					
VVDD-02-1	30-466-06	5	105	100%					
VVDD-04-1	30-466-07	6	140	100%					
VVDD-05-1	30-466-08	5	104	100%					
VVDD-06-1	30-466-09	5	104	100%					
VVDD-11-1	30-466-10	8	219	40%					
etc.									

<b>STEAM HUMIDIFIERS</b>						
Unit Identifier	MMS Identifier	Air flow rate			Steam	
		Flow (L/s)	Temp (°C)	% RH	Flow (kg/h)	Press (kPa)
HUM-1	30-350-01	1,269	12.8	46 to 58	65	90
HUM-2	30-350-02	2,360	12.8	49 to 55	11	90
HUM-3	30-350-03	2,546	12.8	56 to 63	13	90
HUM-4	30-359-04	8,541	12.8	39 to 56	65	90

END OF SAMPLE MMS INPUT INTO WORKING DOCUMENTS

**Sample of Product Information (PI) report form**

(This form is at present being reviewed and re-formatted)

Project:		Project number:		Date:	
Projet:		Numero de projet:		Page:	

**PRODUCT INFORMATION (PI) INFORMATION SUR LE PRODUIT**

Performance Verification (PV) report form accompanies this PI report form: YES

<b>FILTERS / FILTRES - [FINAL / FINALS] [PRE / PRE]</b>	
No. on Contract Drgs/Numero sur le dessin	MMS Identifier/Identification du SSEP:
Description of system/french:	
No. on Contract Drgs/Numero sur le dessin:	MMS Identifier/Identification du SSEP:

<b>PURCHASING INFORMATION/French</b>			
Vendor/Agent Vendeur/Agenc::		Address: Adresse:	
Purchase order no/No. d'ordre d'achat:		Date:	
Ordered by/ Commande par:			
Date of manufacture/Date du manufacture:		Date of start-up/Date du mise en marche:	
Details of Warranty: Details de garantie:		Commencement Debut:	Expiration: n:

<b>PRODUCT INFORMATION / INFORMATION SUR LE PRODUIT</b>			
Man'fr/Manufacturie			
Model/Modele:	Size/Dimension:	Type:	
Serial no/No. de serie:		Rated capacity/french	



Efficiency: [Dust spot] [DOP] Efficacité [Trace de poussière] [ ]	Number & sizes Numéro & Dim		Face Area Façade Air	
Other data Autre données:				

Technician Technicien	Supervisor Superviseur	Date:
Witnessed by Temoin:	Title: Titre:	Date:

## Sample of Performance Verification (PV) Report Form

(This form is at present being reviewed and re-formatted)

Project:		Project number:		Date:	
Projet:		Numero de projet:		Page:	

### PERFORMANCE VERIFICATION (PV) REPORT / RAPPORT DE VERIFICATION DE RENDEMENT

FILTERS - FINAL / FILTRES - FINALS	
No. on Contract Drgs/No. sur le dessin:	MMS Identifier/Identification du SSEP:
Description of system/french:	
No. on Contract Drgs/No. sur le dessin:	MMS Identifier/Identification du SSEP:

<b>FILTERS - FINAL</b> <b>FILTRES - FINALS</b>	Designed Conception	Shop Drawings Dessins d'atelier	Measured Mesuré	Comments Commentaires
<b>TEMPORARY FILTERS:</b> <b>FILTRES TEMPORAIRES:</b> Flow rate:/débit:				
Face velocity:/Vélocité d'entrée				
<b>PRESSURE DROP:/BAISSE DE PRESSION</b> 1. Clean:/Propre 2. Dirty/Sale				
<b>ACTUAL FILTERS:</b> <b>FILTRES ACTUELS:</b> Flow rate:/Débit				
Face velocity:/Vélocité d'entrée				

<b>PRESSURE DROP:/BAISSE DE PRESSION</b>  1. Clean/Propre 2. Dirty/Sale				

<b>FILTERS - PRE</b> <b>FILTRES - PRE</b>	Designed Conception	Measured/ Mesuré	Comments/Commentaire
Flow rate/Débit			
Face velocity/Vélocité d'entrée			

Pressure Drop/Baisse de pression			
1. Clean/Propre			
2. Dirty/Sale			

Technician Technicien	Supervisor Superviseur	Date:
Witnessed by Temoin:	Title: Titre:	Date:

END OF SAMPLE PI AND PV REPORT FORMS

## **Samples of requirements for schematics**

### **Schematics used in manuals, commissioning reports**

**PWGSC A&ES CADD Policy** is set out in the A&ES Policy and Procedures Manual, Sections 4110 through 4114. This policy requires: (1) that drawings, schematics, diagrams, etc. are provided in an electronic format compatible with the CADD systems in current use by PWGSC A&ES; (2) conformity to guideline documents (available in both official languages) from the Documentation Centre at the Tupper Building, Riverside Drive, Ottawa, Ontario K1A 0M2.

**Graphics:** will conform to all Federal standards

**Required information:** Development of schematics, diagrams and graphics shall be based on review of all equipment as actually supplied and installed.

**Basic principles for preparation:** Schematics, diagrams, charts, etc. illustrate and describe O&M requirements. They are prepared by the Designer, who: (1) identifies all equipment, components, etc.: (2) identifies measurement locations, (3) instruments used: (4) data to be presented; (5) shows design values and measured values: (6) describes how the systems will be tested, used and the methodology employed.

Graphics will be prepared by skilled draftspersons.

**Requirements:** will include: (1) Sheet size - either 216 x 279 mm or 279 x 432 mm.: (2) Schematics will be in pre-approved format using 36.24 kg white paper stock with maximum of two folds arranged so that title blocks are always visible, with match lines and reference notes is schematics extend to more than a single sheet; (3) Title blocks similar to the Contract Drawings on right-hand side and permanently visible and include legend : (4) Each system, sub-system to be on a separate sheet: (5) Schematics, diagrams will be easily identified, in workable segments, readily followed and, if necessary, prefaced by an index: (6) They will include complete layout of each system as actually installed, identity and locations of all provisions for TAB, flow measuring and regulating devices, all interfacing with, and points of interconnections into, existing systems, valves, dampers, PRV, air terminal units, heat transfer equipment, duct and pipe sizes, room numbers, floor numbers, system numbers, equipment identifiers, cross-reference to Contract documents, PI and PV Report forms, TAB data, calculation sheets.

### **EMCS graphics:**

Many projects now use EMCS in which graphics play a large role. It may be possible, after approval, to incorporate these graphics into the Systems Operations Manual.

END OF SAMPLE REQUIREMENTS FOR SCHEMATICS

**SAMPLE COMMISSIONING SCHEDULE**

No	Task	Duration	Start	Finish	Dates
	<b>Elevator #1</b>				This area of the table would be used to indicate, in graphic form, dates of start and completion of the activities listed. These would include::  1. Progress of construction / installation (extracted from the Contractor's Construction / Completion Schedule 2. Milestones 3. Factory tests 4. Testing, performance verification and commissioning
44	Mechanical installation				
45	Electrical installation				
46	Controls				
47	Commissioning & testing				
	<b>HVAC System #1</b>				
88	HVAC unit installation				
89	Piping installation to HVAC unit				
90	Electrical installation				
91	HVAC unit Controls				
92	Point-to-point & other tests				
93	Start-up of HVAC unit				
94	Commissioning & Testing				
95	Ductwork installation				
96	Pressure testing of duct systems				
97	Grilles, registers, diffusers installation				
98	Environmental controls installation				
99	Point-to-point verification				
100	TAB				
101	Pressure testing between laboratories				
102	Environmental testing				
	<b>Heating boiler plant:</b>				
132	Factory pres & performance tests				
133	Boiler installation				
134	Electrical installation				
135	Boiler Controls tests				

No	Task	Duration	Start	Finish	Dates
136	Chimney stack installation				
137	Natural gas installation to boilers				
138	Natural gas system testing				
139	Boiler start-up				
140	Boiler feed water piping installation				
141	Boiler feed pump installation				
142	Boiler feed pump start-up				
143	Boiler FW piping pressure testing				
144	Chemical treatment - installation				
143	Boiler room piping installation				
144	Boiler room piping - pressure testing				
145	Flushing and cleaning				
146	Boiler room integrated equipment and system - Start-up and commissioning				
<b>A similar schedule would be developed for chilled water and condenser water systems</b>					
151	<b>Distribution Piping installation</b>				
152	Distribution piping pressure testing				
153	Flushing and cleaning				
154	Permission granted for Contractor to use distribution system for temporary heat				
<b>Boiler room H&amp;V system</b>					
173	H&V unit installation				
174	Piping installation				
175	Electrical installation				
176	Controls				
177	Testing and PV				
178	Boiler room air pressure tests				

No	Task	Duration	Start	Finish	Dates
	<b>Plumbing systems</b>				
211	Acid resisting waste piping install'n below grade				
212	Pressure testing of below grade acid waste piping				
213	Acid waste treatment systems				
214	Acid waste treatment system testing, commissioning				
215	Acid resisting waste piping installation above ground				
215	Pressure testing of entire system				
217	Regular waste and storm water piping installation below ground				
218	Pressure testing of below grade regular waste and storm water piping systems				
219	Regular waste and storm water piping installation system above grade				
220	Pressure testing of entire regular waste and storm water systems				
	<b>HWS systems</b>				
223	HWS Heater and circulating pumps - installation				
231	HWS heater and pumping installation testing and commissioning				
232	Water conditioning system installation				
233	Water conditioning system commissioning				
	<b>Hot and cold water systems</b>				
246	H&CWS piping systems installations				
247	H&CWS piping systems pressure testing				
248	TAB of HWC systems				

No	Task	Duration	Start	Finish	Dates
249	Plumbing fixtures installation				
250	PV & adjustment of plumbing fixtures				
	<b>Laboratory gas piping systems</b>				
270	Piping installations				
271	Bulk oxygen station installation				
272	Testing and commissioning				
273	Medical compressed air station installation				
274	Testing and commissioning				
275	Vacuum station installation				
276	Testing and commissioning				
277	Gas Cylinder station installation				
278	Testing and commissioning				
279	Pressure testing of each system				
280	Lab outlets installation				
281	Testing of piping systems and outlets				
	<b>Electrical</b>				
290	<b>Transformer vault installation</b>				
291	Energization and testing				
292	Metered for use by Contractor				
301	Conduit installation				
302	Electrical wiring installation				
303	Megger testing				
	<b>Low voltage systems</b>				
311	Conduit systems installation				
312	Wiring installations				



No	Task	Duration	Start	Finish	Dates
313	Testing and commissioning				
	<b>Communications system</b>				
333	Conduit installation				
334	Wiring installations				
335	Speakers installation				
336	Controls console installation				
337	Testing and commissioning				
340	<b>Lightning protection installation</b>				
341	testing				
	<b>Emergency power installation</b>				
351	Generator #1 installation				
352	Transfer switch installation				
353	Transfer switch testing				
354	Generator fuel installation				
355	Generator exhaust installation				
356	Ventilation system installation				
357	Ventilation system testing & Cx				
358	Integrated system testing & Cx				
	<b>Lab Fume Hoods &amp; BSC's</b>				
411	LFH and BSC installation				
412	Exhaust ducting installation				
413	Controls				
414	Electrical installation				
415	Lab services installation				
416	Exhaust fan and ducting installation				

No	Task	Duration	Start	Finish	Dates
317	LFH & BSC testing and Cx				
418	Integrated testing with HVAC systems				

END OF SAMPLE COMMISSIONING SCHEDULE

## **Sample specification for Performance Verification of equipment NMS Section 13920 - Fire Pump**

1. General
  - .1 In accordance with ANSI/NFPA 20, supplemented as specified herein.
  - .2 In accordance with Section 01810 - Commissioning: General Requirements, supplemented as specified herein.
  
- .2 Field test each fire pump, driver and controllers in accordance with ANSI/NFPA 20.
  
- .3 Testing to be witnessed by [Fire Commissioner of Canada] [Canadian Forces Fire Marshal] [authority having jurisdiction.]
  
- .4 Develop, with [Engineer] [Consultant] [Owner] assistance, detailed instructions for O&M of this installation.
  
- .5 Disposal of water
  - .1 Discuss appropriate measures for provision and disposal of water used in testing with Engineer.
  
- .6 Co-ordination
  - .1 Co-ordinate tests with performance verification of sprinkler systems specified section [\_\_\_\_\_] - [\_\_\_\_\_], [wet] [dry] pipe sprinkler systems specified Section [\_\_\_\_\_] - [\_\_\_\_\_] and standpipe and hose systems specified Section [\_\_\_\_\_] - [\_\_\_\_\_].
  
- .7 Testing to be witnessed by Fire Commissioner of Canada and authority having jurisdiction.
  
- .8 Allow operating conditions to stabilize at test conditions before taking measurements.
  - .1 Tests for at least 10 minutes under each of minimum, rated, peak load conditions to verify:

- .1 No overheating of any component.
  - .2 No excessive vibration of unit.
  - .3 No vibration transmitted to structure.
  - .2 During each test, measure inlet and outlet pump pressures, rates of flow, electrical power draw, pump speed and plot these points on pump characteristic curves.
  - .3 Test controllers and transfer switches using manufacturer's recommended procedures. Perform at least ten (10) automatic and ten (10) manual operations during this test.
- .9 Timing:
- .1 Perform tests when there is no risk of freezing conditions.
- .10 Identification:
- .1 Verify that all devices are properly labelled, identifying area served, etc.
- .11 Reports:
- .1 In accordance with requirements of Section 01818 Commissioning Reports supplemented as specified herein.
  - .2 In addition to reports required by NFPA 20, include at least following:
    - .1 Purchasing information and product information for all equipment. Refer to Section 01817 Commissioning: Report Forms and Schematics.
    - .2 Manufacturer's characteristic curves (family of curves) for fire pump.
    - .3 Drawings or schematics showing locations and types of controls and components.
- .12 Training:
- .1 Refer to Section 01815 Commissioning: Training of O&M Personnel.

END OF SAMPLE SPECIFICATION FOR PERFORMANCE VERIFICATION OF  
EQUIPMENT

## **Sample of specification for integrated systems test for laboratory**

### **1 General**

- 1 In accordance with Section 01810 - Commissioning: General Requirements, supplemented as specified herein.

### **2 Purpose**

- 1 To determine:
  - .1 Operation of all systems working in unison.
  - .2 Response to normal, emergency and "what if" conditions which may occur during laboratory operations.
  - .3 the ability of the EMCS to perform as designed under change-over conditions from normal power to emergency power.
  - .4 that performance of integrated system is as designed and with proper interaction between related systems, equipment and components.

### **3 Commissioning agency:**

- .1 To be [independent Commissioning Agency] [\_\_\_\_\_]
- .2 Responsibilities to include:
  - .1 Coordinate and conduct tests and fine-tuning of integrated systems.
  - .2 Correct deficiencies identified during integrated systems testing and fine-tuning.
  - .3 Diagnose problems.
  - .4 Modify operating parameters as necessary to satisfy fine-tuning requirements required by Engineer so as to satisfy proper system operation, including adjustments which may become apparent as testing proceeds, modifications to suit changes in system operation as equipment settles down during the "running-in" period.

### **4 Acronyms:**

BSC:	Biological Safety Cabinet
DBT	Dry bulb temperature
DP	Differential pressure
EA	Exhaust air
EMCS:	Energy Management & Control Systems

FA	Fire alarm
HEPA	High Efficiency Particulate air
HVAC:	Heating, Ventilation, Air Conditioning.
LFH:	Laboratory Fume Hood
NC	Noise criteria
PD	Pressure drop (pressure difference)
PV:	Performance Verification
SA	Supply air
SP:	Static pressure
TAB:	Testing, Adjusting and balancing
WBT.	Wet bulb temperature

## **5 Design criteria, design intents**

- .1 DBT, WBT, noise levels, space differential pressure to be maintained in each laboratory at all times within specified tolerances: Refer to Design Criteria and relevant PV Report Forms
- .2 Laboratory DP must not be permitted to go to zero or into opposite pressure values.

## **6 Application tolerances:**

- A. For negatively pressurized laboratories:
  1. SA systems: Plus [0] %; minus [10]%
  2. EA systems: Plus [10]%; minus [0] %.
- .2 For positively pressurized laboratories:
  1. SA systems: Plus [10] %; minus [0]%
  2. EA systems: Plus [0]%; minus [10] %.

## **7 Timing:**

- A. Perform tests only after:

1. Architectural finishes completed.
  2. TAB of HVAC systems successfully completed.
  3. TAB of smoke control systems successfully completed.
  4. Commissioning of FA systems successfully completed.
  5. Commissioning of emergency electrical power systems successfully completed.
  6. Commissioning of all BSC's, LFH, snorkels, other laboratory exhaust systems successfully completed.
  7. EMCS is completed and commissioned to point where it may be used for recording system data and dynamic step response data.
- .2 If necessary, occupancy to be coordinated so as to avoid interference with, or interruption of, any integrated systems tests.

## **8 Seasonal constraints**

- .1 Notwithstanding all-inclusive requirements specified herein, additional separate cycles of Integrated Systems Testing may be necessary during opposite seasons for equipment and systems whose full operation is dependent on seasonal conditions.
- .2 This may necessitate carrying out one of these tests after occupancy and during the Warranty Period.

## **9 Engineer's responsibilities**

- .1 To include:
  - .1 Witness tests and certify results.
  - .2 Provide instruction at the same time as the integrated system performance tests.
  - .3 Provide direction and instruct Commissioning Agency so as to satisfy operating requirements.
  - .4 Fully document results, details of adjustments, changes in system operation as systems settle down.
  - .5 During Warranty Period:
    - .1 Take environmental measurements as necessary to identify existing and potential problems.

- .2 Conduct User surveys to determine degree of satisfaction.

## **10 Systems to be tested**

- .1 These tests shall be applied to all Laboratory HVAC and exhaust systems and related systems.

## **11 Commissioning procedures - EMCS**

- .1 With the EMCS in full operation, change over to emergency power and
  - .1 change from normal operation to operation in fire alarm mode.
  - .2 change from normal operation to smoke exhaust mode.
- .2 Return to normal power and simulate failure of EMCS to test operation of smoke exhaust system without EMCS.
- .3 Perform following during integrated system tests:
  - .1 Perform diagnosis of problems which become apparent during testing.
  - .2 Make adjustments which become apparent as testing proceeds.
  - .3 Make modifications to suit changes as equipment settles down during the "running-in" period.
- .4 Carry out fine-tuning and adjustment of systems as needed.

## **12 Commissioning procedures - Integrated VAV HVAC and exhaust systems:**

- .1 Commissioning Agency to become fully cognizant of all Design Criteria and Design Intents. These may include:
  - .1 Assumed diversity of LFH, BSC, snorkel, other exhaust system usage.
  - .2 LFH operating parameters such as types, face velocity, normal operating and maximum sash heights, minimum flow rate through hood with sash fully closed, etc.
  - .3 Need for redundancy of exhaust systems.
  - .4 Type of LFH exhaust system.- manifolded or dedicated.
  - .5 If manifolded, is the general laboratory exhaust on same system.



- .6 If room exhaust system is separate from LFH exhaust system and if LFH exhaust fan goes down or LFH exhaust air valve fails, possibility for air to be drawn from the LFH into the room.
- .2 The following commissioning procedures are basic only. They may have to be modified for each laboratory, type of LFH, BSC, other exhaust system, supply system, controls, type of supply and exhaust tracking systems used.
- .3 Commissioning to include
  - 1. verification of the integrity of the laboratory envelope,
  - 2. performance verification of maintenance of design DBT, %RH and noise levels in each laboratory at all times while at the same time maintaining design offset between supply air and exhaust air:
    - .1 at maximum and minimum supply and exhaust air flow rates,
    - .2 at various part load conditions of heating and cooling,
    - .3 in "occupied" and "unoccupied" modes,
    - .4 with LFH's at varying sash positions,
    - .5 with BSC's in various modes of operation,
    - .6 with other laboratory exhausts in various modes of operation, and
    - .7 at various combinations thereof.
  - .3 Verify tracking of LFH VAV EA flow rate with SA flow rate from maximum to minimum and record pressure conditions at all exhaust system air valves.
  - .4 Track laboratory supply system from maximum to minimum flow rates and record pressure conditions at all supply system air valves and outlets.
  - .5 Verify integrity of control system and response to within  $\pm 5\%$ . including:
    - .1 Verify stability of zero drift, span shifts, laboratory DP.
    - .2 Investigate all possible control scenarios to determine if there is any one sequence of operations which will cause lab DP to go to zero or into opposite pressure values.
    - .3 Using repeated cycling of controls, determine if the control loops will require periodic re-calibration.
  - .6 Using recording instruments, challenge LFH face velocity by:
    - i. raising and lowering the sash quickly implementing emergency purge procedures.

- ii. simulating EA failure through LFH by exhaust fan or air valve failure.
  - iii. simulating SA failure by supply fan or VAV box failure.
- .7 Track laboratory DP under all possible combinations of operating conditions, such as:
  - i. All LFH sashes fully open or fully closed.
  - ii. Maximum heating and cooling, minimum heating and cooling.
  - iii. LFH sashes randomly ion partially closed and open positions.
- .8 Identify the position of the sash below which the face velocity rises above the maximum design face velocity or fall below the minimum design face velocity.
- .9 Verification of direction of air flow through doors into the space. This can be by propping the door open about 100 mm, and measuring velocity and direction of air flow through the opening every 150 mm from top to bottom.
- .10 Measure all LFH exhaust duct flow rates and velocities and ensure that each stack discharge is in excess of required velocities.
- .11 Performance verification and demonstration of speed of response (in seconds) in the event of:
  - .1 failure of LFH or BSC air valve to minimum and to maximum,
  - .2 failure of laboratory supply air valve, exhaust air valve to minimum and to maximum,
  - .3 failure of supply fan, exhaust fan,
  - .4 failure of normal electrical power and transfer to emergency power,
  - .5 partial and total failure of EMCS,
  - .6 major chemical spills, where the operation of an emergency pull station maximizes exhaust from the laboratory, increases the negative pressure in the laboratory and informs the central control facility,
  - .7 fire or smoke emergency conditions, in which the FA system stops supply fans serving the fire zone, maximizes general exhaust systems so as to increase the negative pressure in the fire zone relative to surrounding fire or smoke control zones.
- .12 Verification that all exhaust fan discharge ducts in Mechanical Room are fully welded and have been pressure tested and that shaft seals of exhaust fans are tight.

- .13 Verification that indirect connections between BSC's and the manifolded exhaust system will never permit any spillage.
- .14 PV of all snorkels and other exhausts for design exhaust flow rates at all times.
- .15 Survey of supply air to ensure that air velocity and air flow patterns in vicinity of LFH and BSC are within parameters of The Standard.
- .16 Examination of very low leakage dampers on inlet to each exhaust fan for leakage when closed, to permit removal of exhaust fan from the system and to permit O&M personnel to service same without exposure to exhaust air.
- .17 Examination of manifold exhaust ducting for condensation under low flow conditions.
- .18 Verification that exhaust stack discharge exceeds 15 m/s (3000 FPM) at all times.
- .19 PV of lead-lag arrangements for exhaust fans, including automatic change-over.
- .4 Measurement of DP: Either directly or indirectly depending upon design requirements:
  - .1 Direct measurement of DP between laboratory and reference point.
  - .2 Indirect measurement by maintenance of differential between SA and EA flow rates using air flow measuring stations in all ducts.
- .5 Multi-point data loggers may be used to:
  - .1 log each exhaust, laboratory supply, response time,
  - .2 track exhaust system from design maximum flow rate to design minimum flow rate by monitoring conditions at the most remote LFH or BSC,
  - .3 track supply system from design maximum flow rate to design minimum flow rate by monitoring conditions at the most remote supply air valve,
  - .4 record DBT, %RH and total offset between supply air and exhaust air.

**13 Commissioning manifolded laboratory exhaust systems:**

- .1 Exhaust systems to include general laboratory exhaust, LFH, BSC, snorkels, (elephant trunks), other special exhausts.
- .2 Establish SA and EA flow rates at design conditions. Set LFH sashes to design position. Measure DP or SA-EA flow rate offset. Make necessary repairs and/or seal leaks until design values are achieved.
- .3 Measure DP or SA-EA flow rate offset for all other possible operating conditions such as:

- .1 sashes on all LFH CLOSED, cooling load at MAX.
- .2 sashes on all LFH OPEN, cooling load at MIN.
- .3 sashes on all LFH CLOSED, cooling load at MIN.
- .4 Determine response time (in seconds) while:
  - .1 raising and lowering LFH sash quickly,
  - .2 implementing emergency purge conditions,
  - .3 simulating LFH EA failure,
  - .4 simulating general EA failure,
  - .5 simulating SA flow rate failure.
- .5 Using multi-pen data-logger to record:
  - .1 SA, LFH EA, general EA flow rates,
  - .2 differential pressure,
  - .3 response time (in seconds).
- .6 Track entire exhaust system from design maximum flow rate to minimum flow rate by monitoring SP at most remote EA valve and face velocity at most remote LFH.
- .7 Track entire supply system from design maximum flow rate to minimum flow rate by monitoring SP at most remote SA valve and face velocity at most remote LFH.
- .8 Record DBT, WBT and DP on 7-day strip chart recorder.

#### **14 Laboratory airlocks:**

- .1 Purposes: To demonstrate directions of air flow towards space of highest contamination when entering or leaving laboratory.
- .2 Applicable air lock systems: [refer to PV Report Forms] [\_\_\_\_\_].
- .3 Timing: After integrated systems tests for stable operation and laboratory operations have been successfully completed.
- .4 Conditions at time of tests:
  - .1 Supply and exhaust air systems functional, airlock entry controls operational.
  - .2 Laboratory operational, functioning normally, including monitoring.

- .3 Adjacent areas operating normally.
- .5 Design intents:
  - .1 Entry/Exit process to be bi-directional.
  - .2 In either entry or exit, it must be possible to turn around and return to starting point.
  - .3 If access is denied, it must be possible to turn around and return to starting point.
  - .4 In event of fire conditions, door controls to be released, access to be available in either direction.
- .6 Procedures:
  - .1 Start air systems, allow to stabilize, continue to operate for [60] minutes, then shut down.
  - .2 Execute entry and exit sequences according to established operational protocols.
  - .3 Using instrumentation and smoke tests, monitor and record flow and pressure variables and response time for laboratory and associated air locks throughout +entry and exit protocols.
- .7 Acceptance requires that:
  - .1 Directional air flow in laboratory to be maintained throughout tests.
  - .2 Pressure in all laboratories associated with air system serving this laboratory remain as designed.
  - .3 Safe egress to be maintained at all times. Force on doors to conform to requirements defined in PV Report Forms.

## **15 Pressure decay tests of welded ducts**

- .1 Apply this test only to those portions of laboratory ducted air systems required to be welded for contaminant containment purposes.
- .2 Perform pressure decay test as described in ANSI/ASME N510-1989, section 6.5.3 "Duct and Housing Leak Rate Test (Pressure Decay Method).
- .3 Ductwork to be closed off and sealed between HEPA filter housing and room by closing airtight dampers or, in absence of dampers, by sealing openings to ductwork.
- .4 Application tolerances: Not more than 0.2% of the flow rate at 500 Pa.

**16 Other laboratory exhaust systems**

- .1 Application tolerances: Plus [10]%; minus [0].
- .2 Standard: As for HVAC systems
- .3 TAB procedures:
  - .1 TAB as per standard.
  - .2 Plugs for test openings: To match duct materials specifications.
  - .3 Upon completion of TAB, perform activities specified this section.

**17 Records of tests**

- .1 Use EMCS to record systems data and dynamic step response data.
- .2 Where EMCS points not available, use manually recorded parameters.
- .3 Monitor, record effects, note response times of various operational and failure conditions on systems.
- .4 Measure variable on real-time basis. Utilizing this data, make fine-tuning adjustments as necessary.
- .5 Present test data and results in data file and graphic format.
- .6 Engineer to develop project-specific PV forms.

**18 Air systems - Stable operation:**

- .1 Purpose:
  - .1 To demonstrate operation and accuracy of air systems.
  - .2 Applicable air systems: All systems in the new facility.
- .2 Conditions at time of tests: All equipment and systems to be operational in automatic mode.
- .3 Procedures: Start air systems run for [60] minutes to stabilize conditions.
- .4 Conditions for Acceptance: Requires:
  - .1 Control of variables associated with test.

- .2 Stable and dynamic system response to laboratory disturbances to permit performance of remaining tests.
- .3 Maintenance of standard steady state conditions listed in PV Report Forms.

**19 Normal laboratory operation**

- .1 Purpose: To demonstrate that laboratory and associated BSC's, LFH's and snorkels are maintained in safe condition during normal laboratory operation.
- .2 Applicable laboratories: All laboratories in this facility.
- .3 Timing: Perform these tests after tests for stable operation (specified this section) successfully completed.
- .4 Required steady state conditions: Refer to Performance Verification (PV) Report Forms.
- .5 Conditions at time of tests: Laboratory supply and exhaust systems to be operational.
- .6 Procedures:
  - .1 Assume PD across HEPA filters = 250 Pa
  - .2 Start air systems, allow to stabilize, run for [60] minutes, then shut down.
  - .3 Monitor, record flow and pressure variables, response times for lab to reach steady state conditions.
  - .4 Using instrumentation, smoke tests, demonstrate directional air flow.
- .7 Acceptance: requires that:
  - .1 Directional air flow to be maintained.
  - .2 Pressure in all laboratories associated with air system serving this lab remain as designed.
  - .3 Safe egress to be maintained. Force on doors to conform to requirements defined in PV Report forms.

**20 BSC and LFH failure**

**21 Supply fan failure**

- 22 Laboratory supply air failure**
- 23 Maximum supply air to laboratory**
- 24 Exhaust fan failure**
- 25 Laboratory exhaust air failure.**
- 26 Maximum exhaust from laboratory**
- 27 Electrical power failure to laboratory**
- 28 Building power failure**
- 29 Activities upon completion of commissioning**
- 30 Commissioning Reports**
- 31 Training**
- 32 Commissioning activities during Warranty Period**
- 33 Laboratory training upon occupancy and during Warranty Period**

END

SAMPLE OF SPECIFICATION FOR INTEGRATED SYSTEMS TEST FOR LABORATORY

**CP.1: PROJECT COMMISSIONING MANUAL  
END OF APPENDIX A**





# Appendix B

## Commissioning Glossary (CP.2)

### **Acceptance**

The acceptance by the Owner/Investor of responsibility or ownership of the facility/service/product delivered under the Contract and which, in the opinion of the Owner/Investor, conforms to all terms and conditions of the Contract.

### **Adjusting**

Regulation of the built works as necessary to meet required flow rates, modes of operation, and so on.

### **Amended Commissioning Plan**

The Commissioning Plan as amended in the light of components, equipment, sub-systems, systems approved for installation, suppliers' delivery schedules, the contractor's construction and completion schedule, the user's occupancy schedule, and consideration of all other conditions pertaining to commissioning.

### **"As-built" drawings and specifications**

Drawings prepared from the Project Record Drawings, and providing an accurate record of the project as built and operating. They may be supplemented by schematics and diagrammatic layouts. "As-built set point" drawings also include:

- .1 amendments to show all measured and approved results of performance verification procedures, settings of all controls, systems and equipment as finally set upon completion of commissioning. It also includes project specifications amended by insertion of addenda, change notices, etc.
- .2 flow diagrams and piping schematics as installed at each major item of equipment complete with valves controllers, etc. identified with numbered tags.

### **Average effectiveness level**

The capability of all parts of the built works to meet specified requirements and to maintain this level of operation without interruption for a specified test period.

### **Balancing**

The proportioning of flow rates within a distribution system to meet requirements.

### **Breakdown maintenance**

The prompt correction of unpredicted or unpredictable breakdowns or failures and the making good and restoration to the original level of durability, reliability, efficiency and safety.

### **Building management manual (BMM)**

The manual provided to the Propert Manager, considered as the project's "Owners Manual", which explains what systems, equipment and/or components were incorporated into the building, why they were selected, how the design and operating concepts of the sub-systems, systems and integrated systems are accomplished, and includes the design criteria, design intent, design philosophy, how the design meets the Client's functional and operational requirements, standard operating procedures (SOP) manual and operating and maintenance (O&M) manual. Refer to CP.3 for details.

**Built works**

Includes all static and dynamic systems and installations, all components, equipment, sub-systems, systems, integrated systems, controls constructed and installed as part of the project.

**Certificate of completion**

See *General Conditions*. There are two types: "Interim" and "Final".

**Client**

Usually, but not invariably, the Owner/Investor.

**Commissioning (Cx)**

A planned program of activities that advances the built works from the earliest Phase to a condition of full operation, meeting all objectives of commissioning as defined in the Commissioning Brief.

**Commissioning activities**

See "*Commissioning Procedures*".

**Commissioning agency**

See "*Commissioning Agent*".

**Commissioning Agency**

The person(s) or company qualified and approved to carry out commissioning activities and procedures. The Commissioning Agency may change, depending upon the equipment, system, integrated system being commissioned. It may be the installing contractor, a qualified Testing, Adjusting and Balancing (TAB) Agency, a special Commissioning Agency, etc. (except in cases where the TAB contractor is already under contract on the same project)

**Commissioning agent**

The General Contractor's delegated person with established reputation in commissioning to oversee all commissioning activities by all commissioning agencies and to be the single point of contact for the Designer, Engineer and PWGSC Commissioning Manager in all matters relating to commissioning. Qualifications are described in *PWGSC Commissioning Manual (CP.1)*".

**Commissioning authority**

See "*Commissioning Manager*".

### **Commissioning Brief**

The section of the Project Brief which defines the deliverables describes the objectives and scope of commissioning, defines commissioning requirements based upon a detailed study of the User's requirements, and establishes roles and responsibilities for commissioning activities.

### **Commissioning documentation**

A complete set of data and information fully describing the project as a built, finished, functional and operational facility. It includes the "As-built" plans and specifications, working documents, systems design documents, all approved shop drawings and product data, inspection certificates, operating and maintenance manuals, and Building Management Manuals.

### **Commissioning Engineer**

The Designer (Architect, Engineer or other professional producing the design solution meeting the User's requirements) responsible for observing, witnessing and certifying results of commissioning activities performed by the Commissioning Agency. See also "*Designer*".

### **Commissioning Manager**

The person responsible for the management of all commissioning activities and for providing technical advice to the Project Manager regarding commissioning concerns. Refer to *PWGSC Commissioning Manual (CP.1)*". Depending on the size of the project, the Commissioning Manager may be assisted by a team of qualified representatives of the disciplines involved.

### **Commissioning manual**

The overall document dealing with commissioning as carried out in PWGSC. This manual consists of the "*PWGSC Commissioning Manual (CP.1)*" and a number of "*PWGSC Commissioning Guidelines*", all of which are listed in the Table of Contents of the "*PWGSC Commissioning Manual (CP.1)*". .

### **Commissioning Plan**

The document which describes the organization, scheduling, allocation of resources, documentation, dates, roles and responsibilities for verification that the built works meet Contract Document requirements.

### **Commissioning procedures**

Includes TAB, PV (Performance Verification) and all other activities described in the various Commissioning Procedures Manuals or specified in the Contract Documents.

### **Commissioning Procedures Manual**

A document that describes all the procedures used during the Commissioning process.

**Commissioning process:**

See "*Commissioning*".

**Commissioning Report**

A debriefing report on commissioning to evaluate the commissioning processes used during the project delivery cycle. This report is prepared by the Designer during, and finalized at the end of the Warranty Period and included in the Building Management Manual.

**Commissioning Schedule**

A schedule, cross referenced to the Construction Schedule, which highlights dates and times when key commissioning activities are to be implemented and completed and deliverables provided. This schedule is used to track the progress of the commissioning process throughout the project.

**Commissioning Team**

The Commissioning Team is usually represented by the Commissioning Manager during the NPMS *Project Delivery Stage*. For roles and responsibilities and team definition, refer to "*PWGSC Commissioning Manual (CP.1)*".

**Completion**

The point at which all terms of the Contract have been fulfilled to the satisfaction of the Project Manager. See "*General Conditions*".

**Components**

Individual devices, forming part of equipment, sub-system or system.

**Concept drawings**

Drawings prepared by the Designer to show the design concept.

**Conceptual design**

See "*Design Concept*".

**Construction schedule**

The detailed schedule prepared by the Contractor which establishes the scope and approach to project construction operations and incorporating the Amended Commissioning Plan. See also "*Commissioning Schedule*".

### **Construction Team**

The Construction Team is usually engaged following successful bidding on the project and being awarded the construction contract. This team completes its work at the end of NPMS *Project Delivery Stage, Implementation Phase.*, when the management of the completed facility passes to the Property Management Team for operation. The services of the Construction Team may be required during the NPMS *Project Delivery Stage, Delivery Close Out Phase* if construction difficulties become apparent.

### **Consultant**

See "*Designer*".

### **Contract documents**

The Working Documents upon which the contract with the Contractor to deliver the project is based. Usually includes drawings and specifications.

### **Contractor**

Includes sub-contractors, manufacturers, suppliers, vendors, fabricators and sub-trades.

### **De-commissioning**

Facilities which are taken out of service, mothballed, shut down or otherwise made non-operative.

### **Defect**

Any variation in form, fit or function from the Design Intent, Design Criteria or Contract Documents.

### **Demonstrations**

Operation of the built works in the presence of the Project Manager, Commissioning Manager, Client/Investor and/or User to confirm installation and operation in conformity to Commissioning Documentation.

### **Design-Builder**

See both "*Designer*" and "*Construction Team*".

### **Design concept**

The design solution as developed by the Designer and meeting all requirements of the Project Brief. It is the result of analysis of the problem or opportunity, and investigation of the various options. For detailed description of contents, refer to the "*Project Management Manual. (CP.1)*".

### **Design criteria**

All those factors included in the design of a facility prescribed by the Project Brief or determined by the Designer as necessary in order to meet all requirements of the Owner/Investor.

### **Designer**

The Architect, Engineer or other professional producing the design solution meeting the User's requirements. In the context of the Project Brief, the term used is "Consultant".

### **Design intent**

The methodology employed by the Designer which is intended to meet the Design Criteria.

### **Design Team**

The Design Team is usually assembled at the end of NPMS project delivery stage, planning phase and continues to work as a team until the end of NPMS project delivery stage, implementation phase.. The services of the Design Team may be required during NPMS project delivery stage, close-out phase, in the event of design difficulties.

### **Durability**

The average expected service life before failure, based upon the manufacturer's estimate of the hours of operation and also based upon a specific preventive maintenance program.

### **EMCS**

Acronym for Energy Monitoring and Control System. A computerized system with field devices located on building system components to permit monitoring and control of a component, system or integrated system through a central command post or a designated remote station location.

### **Environment**

The output of all related integrated systems. Conditions established within the environment affect, or are affected by, the set points of the components, which in turn adjust, or are adjusted by, the output of the sub-systems, systems and integrated systems.

### **EPVT**

Acronym for Equipment Performance Verification Tests.

### **Equipment**

Devices, components, etc. forming part of a sub-system or system.

## **Evaluation Report**

This report provides an assessment of the project for compliance with the User's functional and operational requirements as describes in the Investment Analysis Report (IAR) and the Project Brief. This report is prepared by the Project Manager with input from the Designer and submitted to the Project Leader after the termination of the Warranty Period and at the end of the Operation Phase.

## **Extended warranty**

A warranty made relating to certain specific items of equipment which is of greater duration than the Warranty Period stipulated in the Contract.

## **Extent of commissioning**

The degree to which components, equipment, sub-systems, systems and integrated systems are commissioned, based upon studies of the User's requirements, effects of such omissions on operating efficiencies, security, health, welfare, comfort, safety, professional and regulatory obligations and liabilities.

## **Facility**

See "*Project*".

## **Facility Management Team**

See "*Property Management Team*".

## **Facility Manager**

Usually called the Property Manager in PWGSC. The person responsible for operation and maintenance of the completed facility.

## **Fine tuning**

The additional adjustments made after commissioning so as to optimize performance and to maximize the benefits of a system, sub-system and equipment.

## **Function**

Includes all modes and sequences of control operation, interlocks and conditional control responses, all specified responses to emergency conditions, etc.

## **Functional performance testing**



See "*Performance Verification*".

### **General conditions**

See PWGSC front-end contract documents.

### **Implementation phase**

A distinct phase within the NPMS Project Delivery Stage during which the built works are checked for static completion, started, tested, adjusted and balanced, operational and functional performance is verified, documentation is verified for completeness, all training is carried out, all facility management plans implemented. At the end of the Project Delivery Stage, the facility is handed over to the Owner/Investor and User.

### **Inspection certificates**

Certificates signed and certified by the authority having jurisdiction which apply to installation, performance verification, commissioning or operation of special systems or equipment.

### **Installation/start-up Check Lists**

A compilation of items that should be examined during pre-start-up inspections. It includes all items specified in the Contract Documents, and items not so specified but considered as essential to good installation engineering practice or necessary for proper operation of the facility.

### **Integrated systems**

Multiple systems driven by the operating parameters of the architectural, structural, mechanical and electrical systems and operating as a coordinated and integrated entity in order to satisfy User's requirements.

### **Interim commissioning**

That portion of commissioning that verifies that the built works are in satisfactory operating condition for initial occupancy.

### **Life cycle costs**

Include capital construction costs, labour, materials, costs of utility connections, utilities such as potable water, thermal energy (heating and cooling), electrical costs, costs of maintenance, repairs and servicing, to operate and maintain the system (or the facility). Depending upon the context, Life Cycle Cost (LCC) may be calculated per annum or over the service life of the facility

## **Maintainability**

A measure of the time required to fully restore the works to perform their intended function after failure with specified procedures and resources. Maintainability of that characteristic of the works which indicates the ease and rapidity with which it can be restored to a specific level of performance.

## **Maintenance management system (MMS)**

A code base system, which is sub divided into a series of numbers/ codes for building devices, components for each base building system such as mechanical (heating/cooling), fire protection, electrical, emergency power systems, fire alarm system. The data base is totally inputted into a computer to permit the effective and timely maintenance / replacement of the building installations, and is used for estimating the life cycle planning.

## **National Project Management System**

The basic framework within which all PWGSC projects are developed, implemented and delivered.

## **Non-acceptance**

The refusal to accept the responsibility/ownership of the facility/service/product delivered under the Contract which, in the opinion of the Owner/Investor, does not conform to the terms or conditions of the Contract.

## **Operating and maintenance budget**

See "*Life Cycle Costs*".

## **Operating manual**

A project-specific manual prepared by the Designer using schematic and diagrammatic layout drawings to fully describe each system, all Design Criteria, Design Intents, its operation (using narrative-type sequence of operation). During the design phase, it is "generic" in the sense that it generally contains no reference to manufacturer's equipment. During construction and commissioning, it is amended to contain all "As-built" information and forms the Operating Manual for the facility.

## **Operation**

The normal day-to-day manipulation of the works as designed in order to fulfill the intent of the design.

## **Operating and maintenance (O&M) manuals**

An organized compilation of all documentation relating to the facility as a built, finished, functional and operational entity. It consists of two separate manuals – the Operating Manual and the Maintenance Manual.

### **Performance verification (PV)**

The checks and tests carried out to determine if the built works function in accordance with the Design Intent.

### **Performance verification report**

Record of all measured data resulting from testing, adjusting, balancing and performance verification for the built works. It includes all product information. See also "*Product Information*".

### **Post-occupancy commissioning**

Commissioning activities carried out after full occupancy and under normal operating conditions, and may include system optimization, commissioning of seasonal-, occupancy- and weather-sensitive systems.

### **Preliminary design**

The development of the Design Concept in more detail and establishment of technical, operational, cost and scheduling requirements in sufficient detail to ensure that subsequent development of Working Documents continue to meet requirements of the Project Brief.

### **Preventive maintenance**

Pre-planned activities designed to ensure the continuance of durability, reliability, operation at peak efficiency, safety of the works, minimize down-time and to prevent unplanned, unscheduled or unpredictable failures by doing work at scheduled intervals. Preventive maintenance includes servicing and corrective maintenance functions. Preventive maintenance anticipates wear and tear during operation, takes corrective actions so as to minimize deterioration.

### **Product data**

Manufacturers' product data sheets provided by the Contractor for factory-fabricated components, equipment, systems, etc., specified in the Working Documents and required for the project. These are approved before purchase by the Contractor. See also "*Shop Drawings*".

### **Product information (PI)**

A compilation of data gathered from all components and equipment installed on the project, including manufacturer's nameplate data and all other information that is necessary for full and complete commissioning documentation. Product information forms part of the Performance Verification Reports.

### **Project**

A package of activities specifically dedicated to fulfilling a program requirement within a prescribed time period, having defined objectives (including scope, performance, quality, cost).

### **Project Brief**

The document which defines all requirements of the project and services to be provided. It includes general project information, scope of the work, time plan, design data and the Commissioning Brief. It contains design instructions to the Design Team and Commissioning Team and is the basis for Consultant's Agreements. Refer also to "*Request for Proposal (RFP)*".

### **Project Leader**

The person representing the Owner/Investor and accountable for the overall project development.

### **Project Manager**

The person responsible for the implementation of a project, including management, administration and coordination of activities.

### **Project record drawings**

The Contract Documents amended by the Contractor on site to show the actual location of all features and materials and all other deviations from those called for in the Contract Documents as made during construction. These amendments are made as the work progresses.

### **Property Management Team**

The Property Management Team receives the facility at time of commissioning and operates it throughout its useful life. The team consists of the Facility Manager, Building Operations Manager, in-house maintenance staff, and service contractors. Members of the Design Team, Commissioning Team and Construction Team may also be included.

### **PV**

See "*Performance Verification*".

### **PWGSC Commissioning Manager**

The person responsible for the management of all commissioning activities and for providing technical advice to the Project Manager regarding commissioning concerns. Qualifications are described in the "*PWGSC Commissioning Manual (CP.1)*".

Depending on the size of the project, the Commissioning Manager may be assisted by a team of qualified representatives of the disciplines involved. The Commissioning Manager represents the Owner / Investor for all PWGSC projects.

### **PWGSC Commissioning Manual**

The document which describes commissioning as carried out in PWGSC.

### **PWGSC Design Quality Review Team**

For definitions, roles and responsibilities, refer to "*PWGSC Commissioning Manual (CP.1)*".

### **QA**

Acronym for Quality Assurance.

### **Quality assurance**

The process by which the Project Manager ensures that the Designer meets all defined objectives. It includes review of the calibre of Designer and installers, adequacy of quality control by the Contractor.

### **Quality control**

The process by which the Project Manager verifies that all levels of quality described in the Project Brief, set out in the Working Documents and installed in the built works, are attained. It includes a process of review and monitoring through all stages of the project, corrective action where appropriate and documentation in the Commissioning Documentation.

### **Quality management**

The process adopted by which the quality of the product delivered is controlled. It includes quality assurance and quality control, reviews for conformity to applicable codes, standards, regulations, generally accepted professional standards and principles.

### **Re-commissioning**

Commissioning activities carried out on an existing system. These systems may, for example, have been changed by additions or deletions, repeated adjustments in settings or operating parameters, etc.

## **Redundancy**

The replacement equipment immediately available for operation in the event of the failure of the equipment presently on-line.

## **Redundancy factor**

The ratio of the excess number of units installed to the number of units required to meet design demand.

## **Reliability**

The length of time that the system will perform its intended function before failure under stated conditions of application and use and with a specific preventive maintenance program. It is the failure rate per unit of time. There are two types of reliability:

- .1 **Inherent reliability:** that which is built into the design (i.e. the reliability which would be possible if each and every component performed throughout its life precisely as the designer planned).
- .2 **Achieved reliability:** that which is actually experienced. It varies with the manufacturing processes, shipping, storage, application, installation and operator's capabilities.

## **Repair**

Making good restoration to full operating condition without necessarily restoration to original level of durability, reliability, efficiency or safety. See also "*Maintenance*".

## **Request for Proposal (RFP)**

A statement, addressed to interested Designers, of needs defining those elements, services and systems that must be provided and the products that must be delivered in order that the facility will meet the User's program needs. Based upon a detailed study of the User's requirements. Refer also to "*Project Brief*".

## **Servicing**

The routine work required to be performed by virtue of owning the facility. The work to be performed to keep the facility in optimum condition and operating safely and at peak efficiency at all times.

## **Shop drawings**

Drawings prepared by the Contractor illustrating in detail their interpretation of the requirements of the Contract Documents for shop or on-site fabrication of various components, equipment, etc. required for the project. These are approved before construction or installation. See also *Product Data*.

### **Start-up Check Lists**

See "*Installation/Start-up Check Lists*".

### **Substantial completion**

For a definition, refer to "*General Conditions*".

### **Sub-systems**

Components and equipment operating (with distribution network if required) in an integrated manner.

### **Systems**

Consist of multiple sub-systems operating in conjunction with one another to provide an operational entity.

### **TAB**

Acronym for testing, adjusting and balancing.

### **Testing**

Includes pressure, leakage, flow rate and performance verification.

### **User**

The end user of the product of the project or the occupant of the facility. It may include the Client.

### **Verification**

The process by which reported results of TAB, PV and commissioning are checked for completeness, accuracy and validity.

### **Warranty**

The promise made by the Contractor to rectify and make good any defect or fault that appears in the work or that comes to the attention of the Minister within the period stipulated in the Contract commencing normally on the date of the Interim Certificate of Completion.

**Warranty inspections**

Refer to "*General Conditions of the Contract Documents*".

**Working documents**

The drawings and specifications developed by the Designer showing the approved design and describing all quality control and quality assurance requirements for the project in sufficient detail for the Contractor to deliver the project.

**END OF APPENDIX B**