

No.	DATE	ISSUES AND/OR MODIFICATIONS	BY
4	2018-02-22	ISSUED FOR TENDER	J.K.
3	2017-02-23	ISSUED FOR REVIEW	J.K.
2	2016-11-04	ISSUED FOR REVIEW	J.K.
1	2016-08-02	PRELIMINARY DESIGN - 66% STAGE	J.K.
0	2016-08-02	PRELIMINARY	J.K.

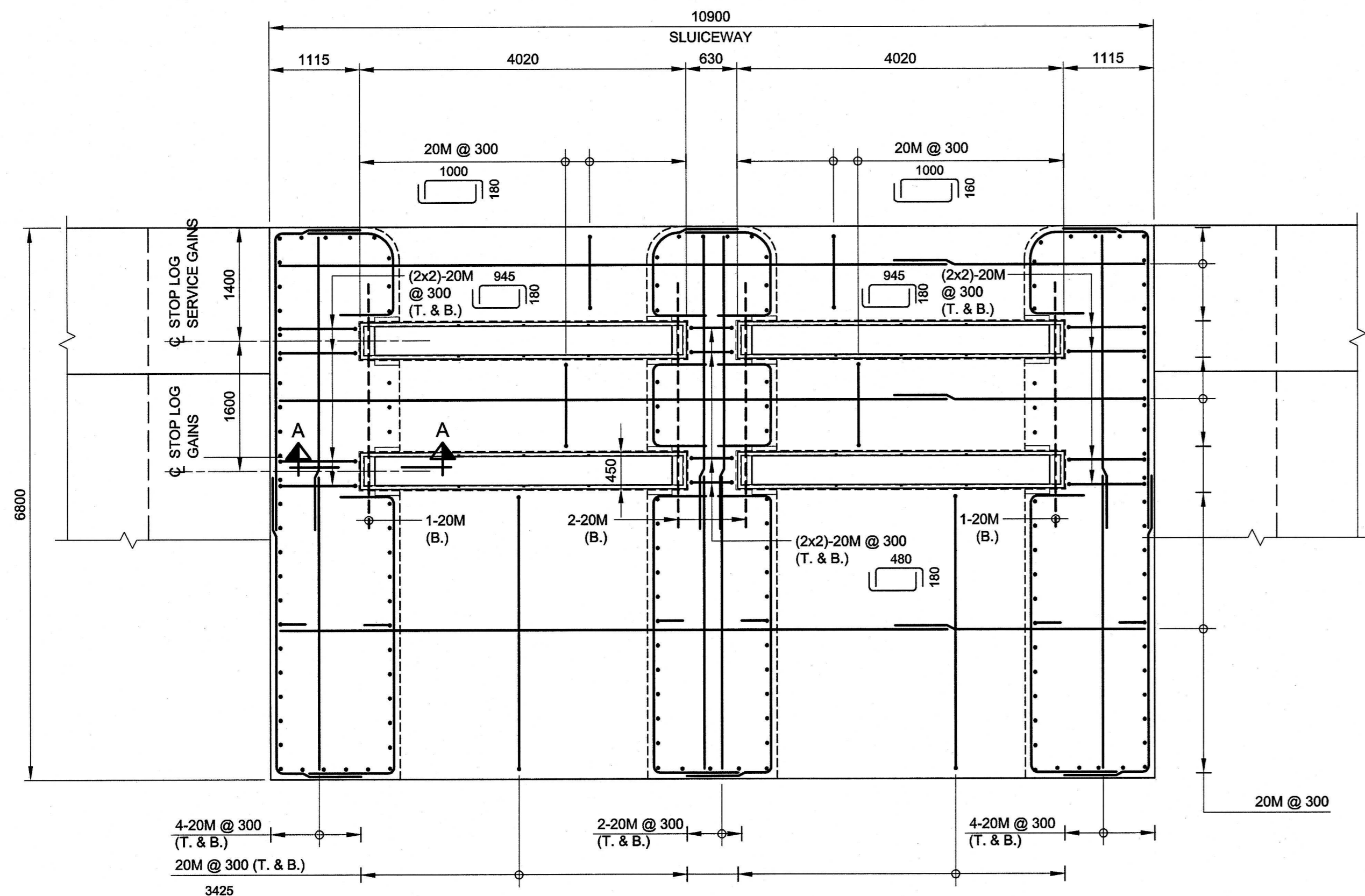

DOWNSTREAM  
PLAN EL. 163.500  
1:50  
REINFORCEMENT

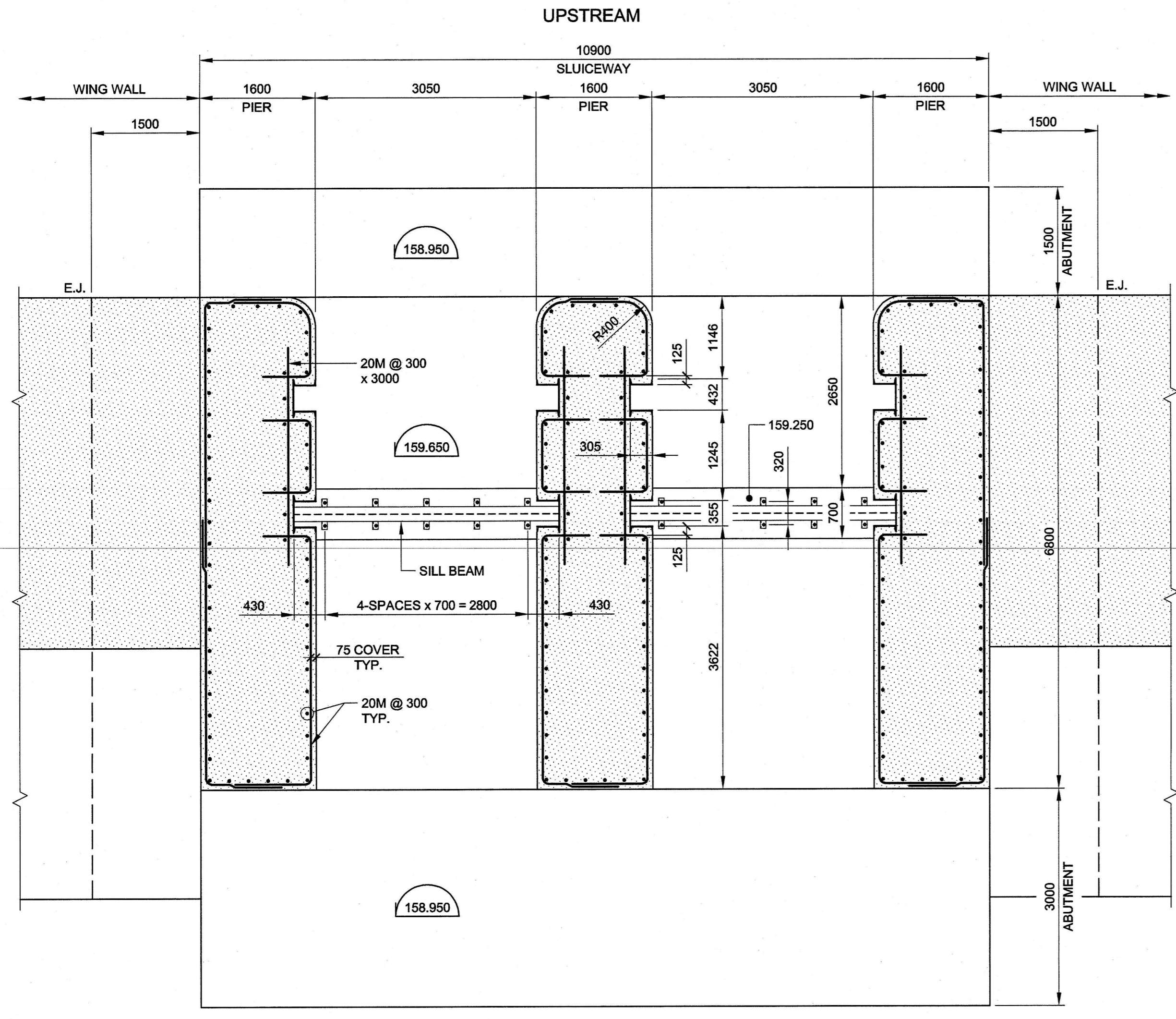

DOWNSTREAM  
PLAN EL. 159.650  
1:50

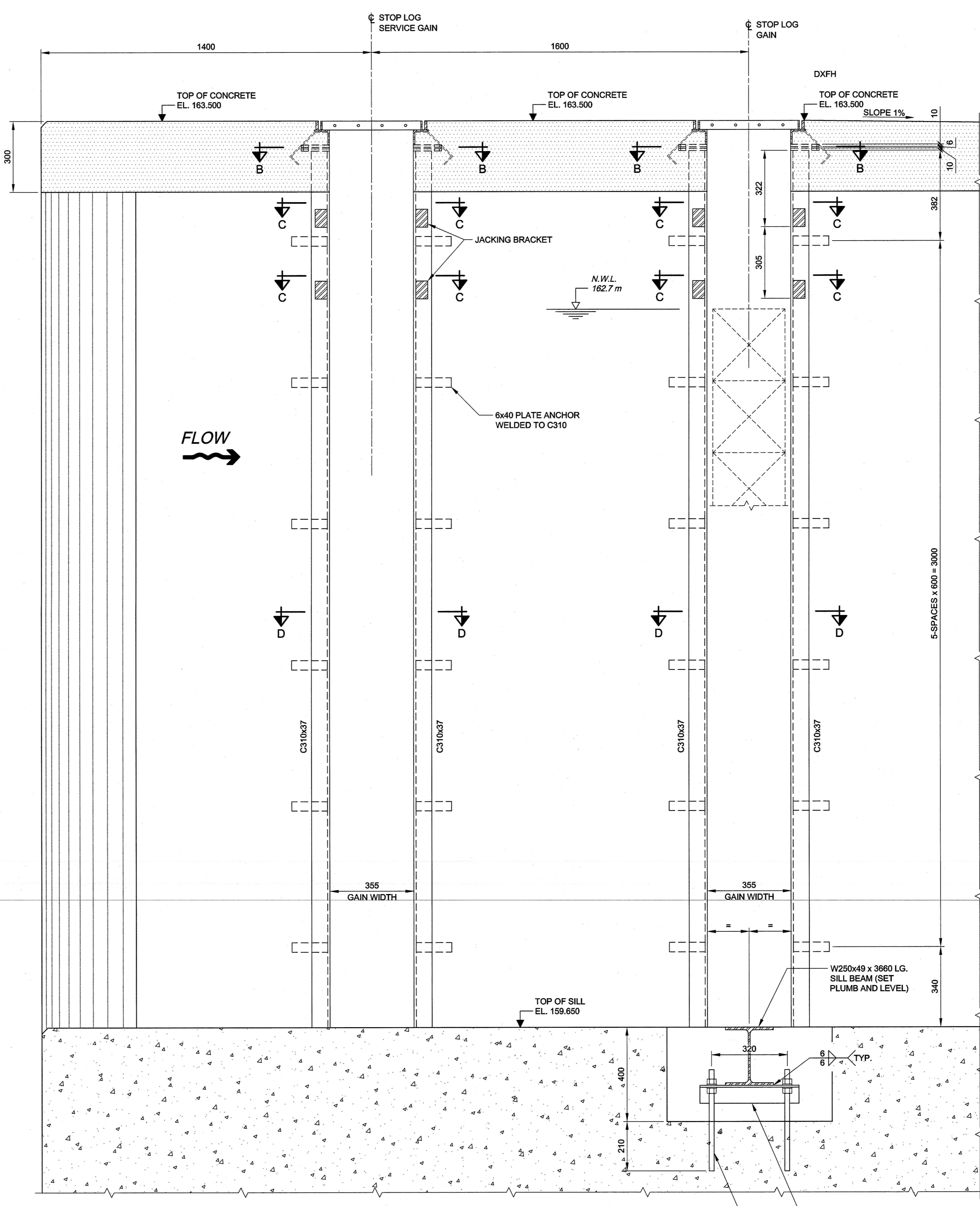

STOP LOG GAINS - ELEVATION  
1:10

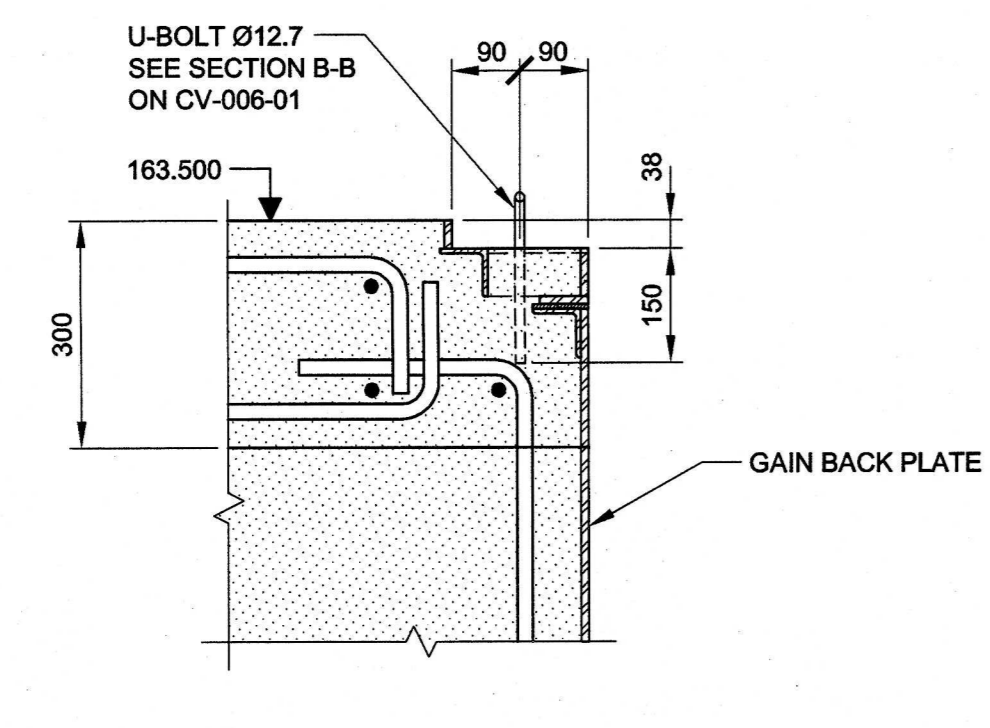

SECTION A-A  
1:10

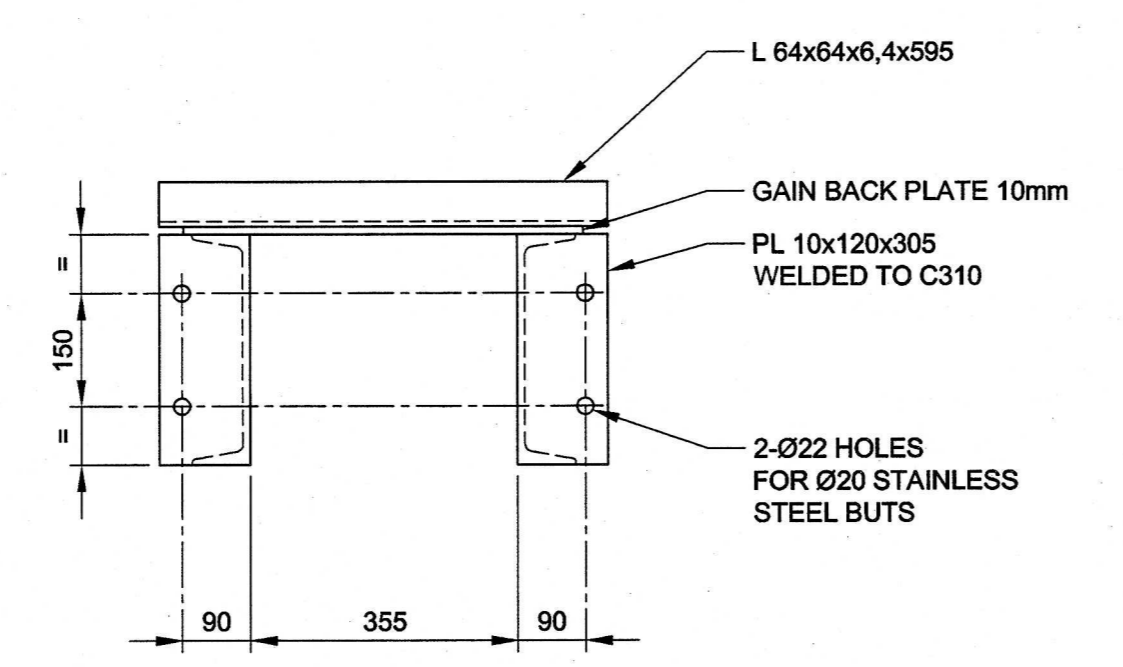

SECTION B-B  
1:10

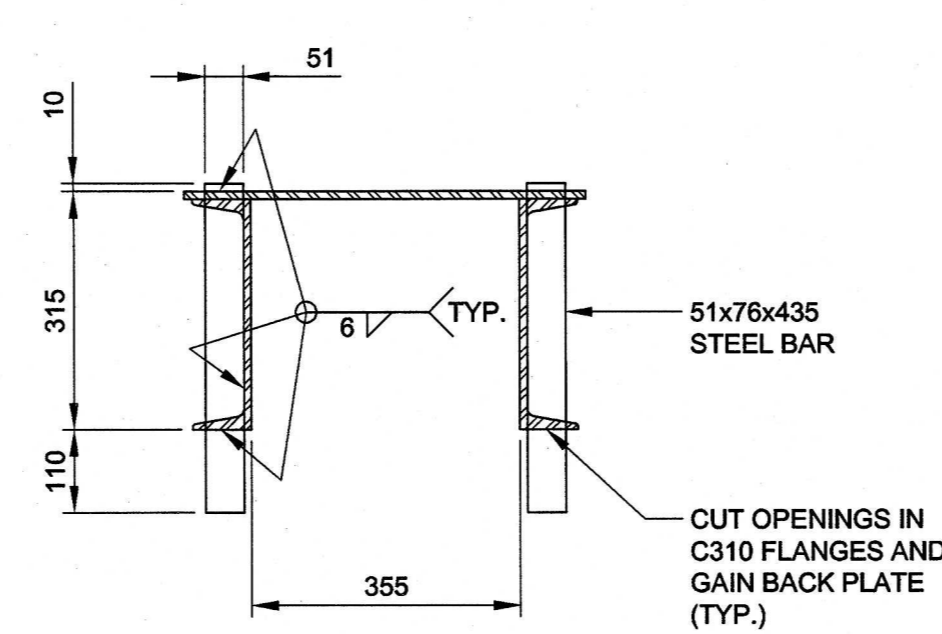

SECTION C-C  
1:10  
(JACKING BRACKETS DETAIL)

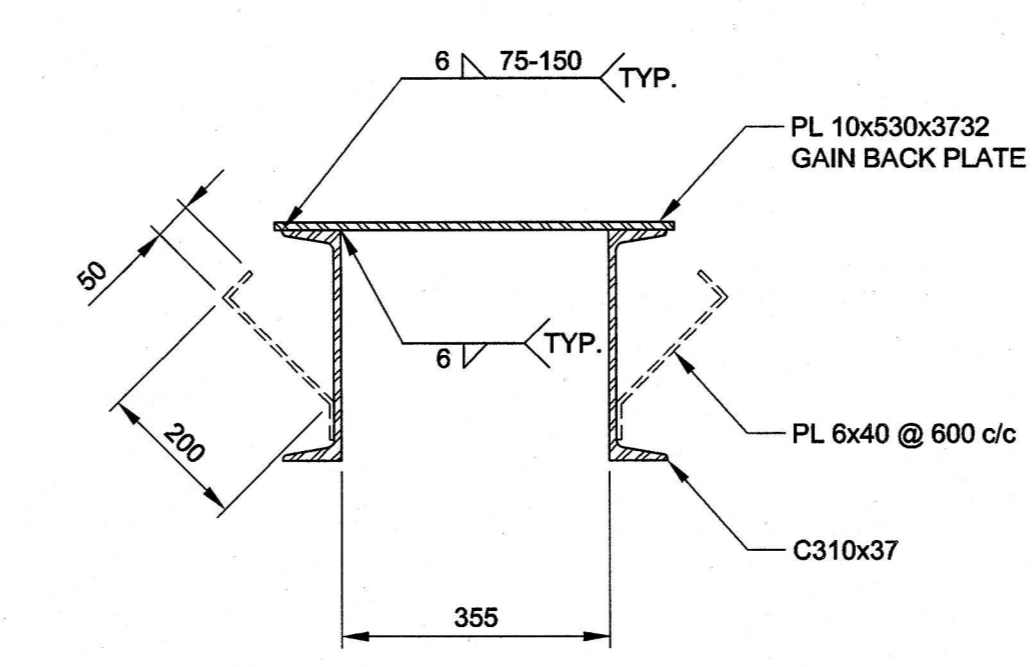

SECTION D-D  
1:10

**NOTES**

- SEE DRAWING CV-002-21 FOR GENERAL NOTES, LEGEND AND ABBREVIATIONS.
- ROUND EDGE OF STEEL PLATE ROUNDED.
- CONSTRUCTION DETAILS OF SERVICE GAINS ARE THE SAME AS MAIN GAINS EXCEPT SILL BEAM AND GAIN COVER.
- ALL STEEL SHALL BE HOT DIP GALVANNESED UNLESS OTHERWISE NOTED.

No.	DATE	ISSUES AND/OR MODIFICATIONS	BY
4	2018-02-22	ISSUED FOR TENDER	J.K.
3	2017-02-23	ISSUED FOR REVIEW	J.K.
2	2016-11-04	ISSUED FOR REVIEW	J.K.
1	2016-08-02	PRELIMINARY DESIGN - 66% STAGE	J.K.
0	2016-08-02	PRELIMINARY	J.K.

**Canada**  
**CIMA**  
900-3400 du Souvenir Blvd  
Laval QC H7V 3Z2  
Phone: 514 237-2462  
Fax: 450 682-1013  
www.cima.ca

**ISO 9001**

**PROFESSIONAL ENGINEER**  
KONCZYNSKI  
106112465  
PROVINCE OF ONTARIO  
2018-02-22

project: **BOBS LAKE DAM REPLACEMENT  
BOLINGBROKE - ONTARIO**

title: **SLUICEWAY CONSTRUCTION PLAN  
SECTIONS AND DETAILS**

drawn: H. OTMANI	scale: AS SHOWN
checked: J. CARON	date: 2015-08-03
designed: K. BEAULIEU DESROCHERS	reference:
approved: J. KONCZYNSKI	

**A0138 | A000492B | CV | 005 | 02 | 4**

2018-02-21  
H:\00000000\Bobs Lake\Construction\000-PLAN\A000492B-CV-005-02-4.dwg