



Fisheries and Oceans
Canada

Pêches et Océans
Canada

Canadian
Coast Guard

Garde côtière
canadienne



Safety First, Service Always



Canadian Coast Guard Procurement Outlook, 2018



- **The Canadian Coast Guard and a picture of procurement at CCG HQ**
- **Small vessels/small craft outlook**
- **Sustainment (VLE)**
- **Delegated Statutory Inspection Program (DSIP)**

Our Services



The Coast Guard is trusted and relied upon to deliver a wide variety of services to Canadians:



Canadian Coast Guard Fleet Assets



- 42 Large Vessels
- 67 Small Vessels
- 4 Air Cushion Vehicles
- 22 Helicopters

Procurement at CCG



Vessel Procurement,
Headquarters

Small Fleet
procurement

Large Fleet
procurement

Marine Engineering,
Headquarters

Small craft
acquisition
(under 15 GT)

Fleet
Maintenance
Program

Life cycle
management

Vessel Refit
and Refurbishment

VLE and MLM

Thinking ahead:
New technology (e.g., 3D scanning)
Greening the Fleet

CCG Small Vessel Outlook*

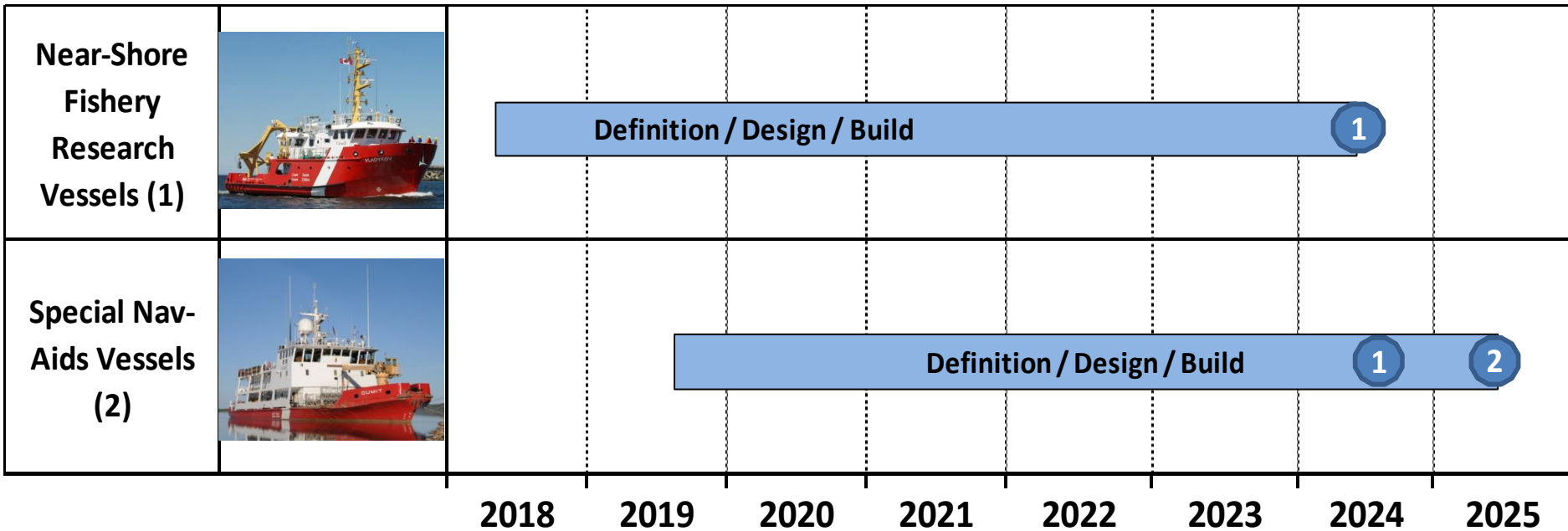

*Notional Schedule – Subject to change based on updates to Fleet Renewal Plan



- **This year, 32 small craft were built (primarily in BC, ON, and NS)**
- **Next year the plan is to deliver an additional 43 small craft**
- **We are currently working with PSPC to commence a solicitation for a new Supply Arrangement**
- **Would be in the range of 25-30 vessel constructors**

Small craft built this year





The VLE-MLM Program is in its 6th year of implementation

Life Extensions continue to help ensure long term sustainability of the Coast Guard Fleet

VLE work packages typically include work items that cannot be conducted within a typical 6 to 8 week refit period

Vessel Life Extension and Mid-Life Modernization



Since 2012, the VLE-MLM Program has made investments totalling 180 million

For 2018/19, the VLE financial forecast is 74 million

Vessel Life Extension and Mid-Life Modernization

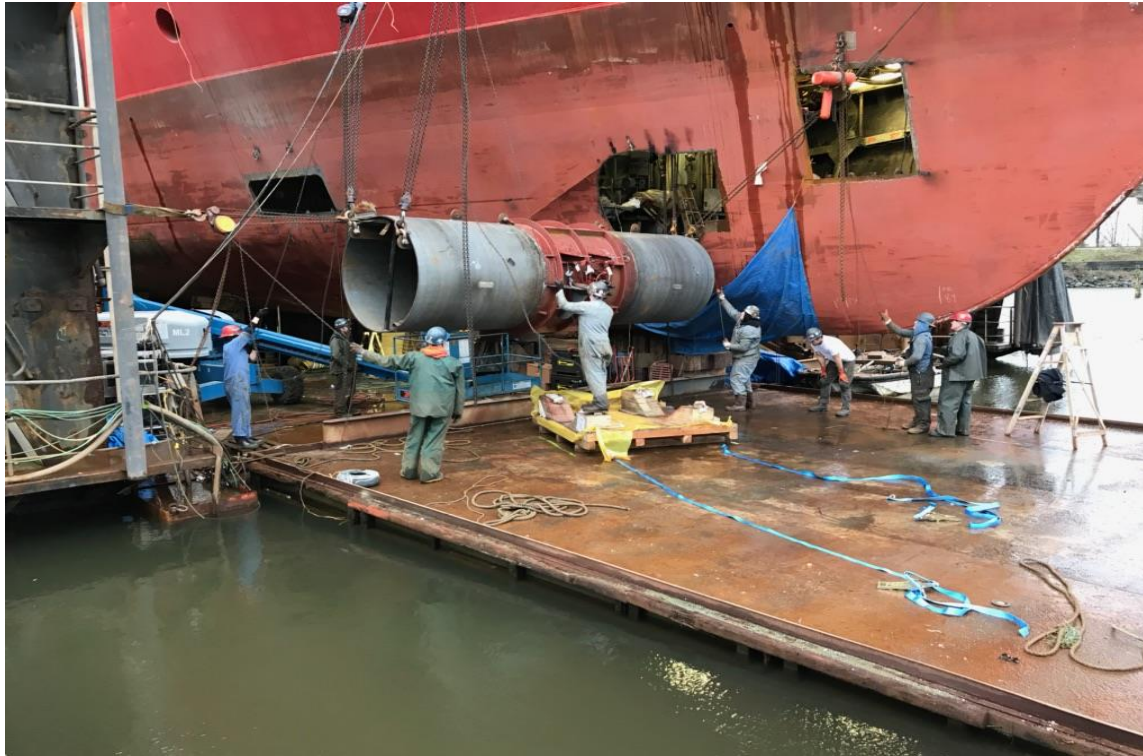

Bowthruster Renewals

Vessel Life Extension and Mid-Life Modernization



Main Engine Renewals

Vessel Life Extension and Mid-Life Modernization

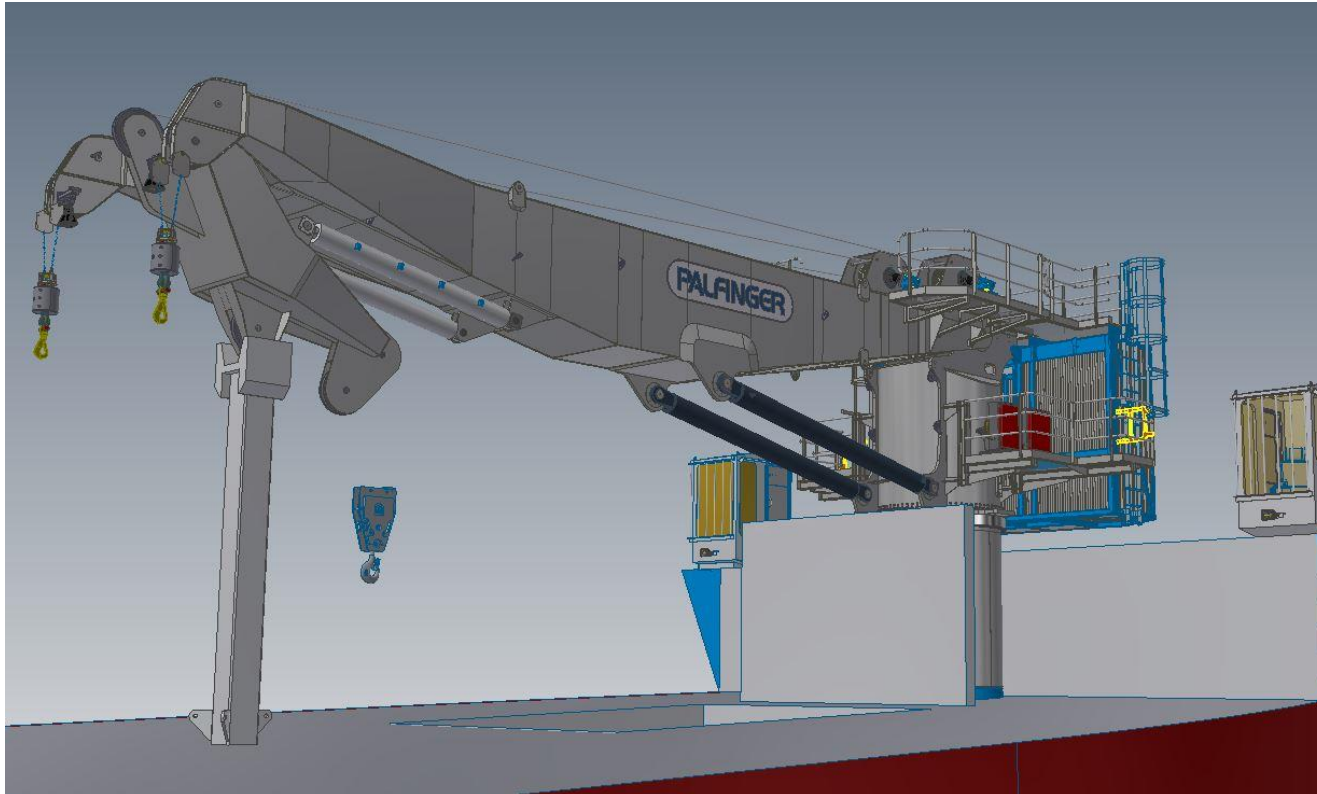

Heavy Lift Crane Renewals

Vessel Life Extension and Mid-Life Modernization



Switchboard Renewals

Vessel Life Extension and Mid-Life Modernization

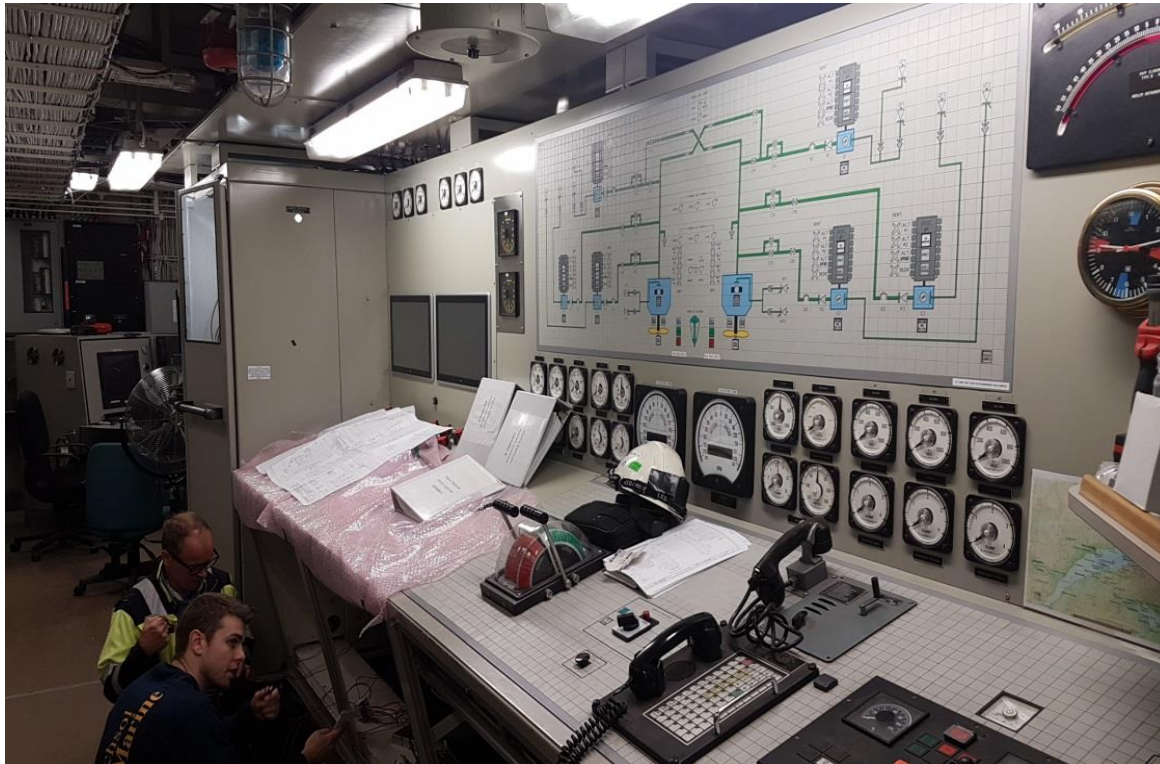

Propulsion Control Renewals

Vessel Refit and Refurbishment



Refit timelines are entered into our 10 Year Refit Calendar (new update coming soon).

This information is located at

<http://www.ccg-gcc.gc.ca/Fleet/Vessel-Maintenance>

Canadian Coast Guard - Ten Year Refit, Drydock, MLM and VLE Calendar

Note - Represented in Fiscal Years - April 1 to March 31	2016-17												
	APR	MAY	JUN	JUL	AUG	SEP	OCT	NOV	DEC	JAN	FEB	MAR	
Atlantic Region													
CCGS Edward Cornwallis					Grey	Grey							
CCGS Sir William Alexander			Green	Green									
CCGS Earl Grey							Green	Green					
CCGS Hudson									Green	Green	Green	Green	
CCGS Alfred Needler									Grey	Grey			
CCGS Ann Hurvay				Green	Green		Yellow	Yellow	Yellow	Yellow	Yellow		
CCGS Cape Roger	Green	Green											
CCGS Cygnes							Green	Green					
CCGS George R. Poirier						Grey	Grey						
CCGS Henry Larson	Grey	Grey	Grey										
CCGS Leonard J. Cowley							Grey	Grey					
CCGS Louis S. St-Laurent		Green	Green										
CCGS Talbot										Green	Green		
CCGS G. Poddie										Grey			
CCGS Corporal McLaren M.M.V.								Green	Green				
CCGS Terry Fox							Grey	Grey	Grey				



In the meantime, here are some notable highlights of our upcoming projects:

- **VLE refit of the CCGS Laurier (2018-2019)**
- **VLE refit of the CCGS Hudson (late 2018)**
- **VLE refit of the CCGS Ann Harvey (2018)**
- **CCGS Des Groseilliers, dry docking work and alongside VLE refit (2018)**

Fleet Delegation/Inspections



- **CCG has decided to enrol the large vessel fleet in the Delegated Statutory Inspection Program (DSIP).**
- **CCG will also examine the possibility of enrolling each vessel in class in addition to having the classification society conduct statutory inspections.**
- **If your company intends to bid on work for the classed vessels, it must be an approved service supplier for the classification society (or equivalent, depending on whether or not the vessel is in Class).**

Questions ?

