



National Defence  
National Defence Headquarters  
Ottawa, Ontario  
K1A 0K2

Défense nationale  
Quartier général de la Défense nationale  
Ottawa (Ontario)  
K1A 0K2

**REQUEST FOR PROPOSAL  
DEMANDE DE PROPOSITION**

**RETURN BIDS TO:  
RETOURNER LES SOUMISSIONS  
À :**

Bid Receiving – PWGSC / Réception des  
soumissions - TPSGC  
11 Laurier St. / 11 rue Laurier  
Place du Portage, Phase III  
Core 0B2 / Noyau 0B2  
Gatineau  
Québec  
K1A 0S5  
Bid Fax: (819) 997-9776

<b>Title/Titre</b> 5340-21-001-3732 <b>ANODE, CORROSION PREVENTIVE</b>		<b>Solicitation No – N° de l'invitation</b>  <b>W8482-194309/A</b>	
<b>Date of Solicitation – Date de l'invitation</b>  10/05/2018			
<b>Address Enquiries to – Adresser toutes questions à</b>  Nashveen Mendes D Mar P 4-3-2-2 Nashveen.mendes@forces.gc.ca			
<b>Telephone No. – N° de téléphone</b>		<b>FAX No – N° de fax</b>	
<b>Destination</b>  See herein			

**Proposal To: National Defence Canada**

We hereby offer to sell to Her Majesty the Queen in right of Canada, in accordance with the terms and conditions set out herein, referred to herein or attached hereto, the goods and services listed herein and on any attached sheets at the price(s) set out therefore.

**Proposition à : Défense nationale Canada**

Nous offrons par la présente de vendre à Sa Majesté la Reine du chef du Canada, aux conditions énoncées ou incluses par référence dans la présente et aux annexes ci-jointes, les biens et services énumérés ici et sur toute feuille ci-annexée, au(x) prix indiqué(s).

**Instructions:**

**Municipal taxes are not applicable. Unless otherwise specified herein all prices quoted must include all applicable Canadian customs duties, GST/HST, excise taxes and are to be delivered Delivery Duty Paid including all delivery charges to destination(s) as indicated. The amount of the Goods and Services Tax/Harmonized Sales Tax is to be shown as a separate item.**

**Instructions: Les taxes municipales ne s'appliquent pas. Sauf indication contraire, les prix indiqués doivent comprendre les droits de douane canadiens, la TPS/TVH et la taxe d'accise. Les biens doivent être livrés « rendu droits acquittés », tous frais de livraison compris, à la ou aux destinations indiquées. Le montant de la taxe sur les produits et services/taxe de vente harmonisée doit être indiqué séparément.**

<b>Solicitation Closes – L'invitation prend fin</b>
At – à : 14 :00 EDT
On - le : May 9 2018

Delivery required - Livraison exigée	Delivery offered - Livraison proposée
Vendor Name and Address - Raison sociale et adresse du fournisseur	
Name and title of person authorized to sign on behalf of vendor (type or print) - Nom et titre de la personne autorisée à signer au nom du fournisseur (caractère d'imprimerie)	
Name/Nom _____	Title/Titre _____
Signature _____	Date _____

---

## TABLE OF CONTENTS

<b>PART 1 – GENERAL INFORMATION-</b> .....	<b>3</b>
1.1 REQUIREMENT – BID .....	3
1.2 DEBRIEFINGS .....	3
1.3 TRADE AGREEMENTS .....	3
<b>PART 2 - BIDDER INSTRUCTIONS.....</b>	<b>3</b>
2.1 STANDARD INSTRUCTIONS, CLAUSES AND CONDITIONS .....	3
2.2 SUBMISSION OF BIDS.....	3
2.3 ENQUIRIES - BID SOLICITATION .....	3
2.4 APPLICABLE LAWS.....	4
<b>PART 3 - BID PREPARATION INSTRUCTIONS .....</b>	<b>4</b>
3.1 BID PREPARATION INSTRUCTIONS .....	5
<b>PART 4 - EVALUATION PROCEDURES AND BASIS OF SELECTION .....</b>	<b>6</b>
4.1 EVALUATION PROCEDURES.....	6
4.2 BASIS OF SELECTION.....	7
<b>PART 5 – CERTIFICATIONS AND ADDITIONAL INFORMATION .....</b>	<b>7</b>
5.1 CERTIFICATIONS REQUIRED WITH THE BID .....	7
5.2 CERTIFICATIONS PRECEDENT TO CONTRACT AWARD AND ADDITIONAL INFORMATION .....	7
<b>PART 6 - RESULTING CONTRACT CLAUSES .....</b>	<b>8</b>
6.1 SECURITY REQUIREMENTS .....	8
6.2 REQUIREMENT .....	8
6.3 STANDARD CLAUSES AND CONDITIONS.....	8
6.4 TERM OF CONTRACT .....	9
6.5 AUTHORITIES .....	9
6.6 PAYMENT.....	10
6.7 INVOICING INSTRUCTIONS .....	11
6.8 CERTIFICATIONS AND ADDITIONAL INFORMATION .....	11
6.9 APPLICABLE LAWS - CONTRACT .....	11
6.10 PRIORITY OF DOCUMENTS .....	11
6.11 DEFENCE CONTRACT.....	12
6.12 SACC MANUAL CLAUSES.....	12
6.13 ASBESTOS .....	12
6.14 PACKAGING REQUIREMENTS .....	12
6.15 QUALITY ASSURANCE .....	12
6.16 SHIPPING INSTRUCTIONS - DELIVERY AND DESTINATION SCHEDULES UNKNOWN .....	12
6.17 EXCHANGE RATE FLUCTUATION ADJUSTMENT.....	12
<b>ANNEX “A” LINE ITEM DETAILS .....</b>	<b>15</b>
<b>ANNEX “B” BASIS OF PAYMENT .....</b>	<b>16</b>
<b>ANNEX “C” LONG TEXT DESCRIPTION .....</b>	<b>17</b>
<b>ANNEX “D” TO PART 3 OF THE BID SOLICITATION .....</b>	<b>18</b>

---

## **PART 1 – GENERAL INFORMATION**

### **1.1 Requirement – Bid**

The Contractor must provide the items detailed under the "Line Item Details" at Annex "A".

### **1.2 Debriefings**

Bidders may request a debriefing on the results of the bid solicitation process. Bidders should make the request to the Contracting Authority within 15 working days from receipt of the results of the bid solicitation process. The debriefing may be in writing, by telephone or in person.

### **1.3 Trade Agreements**

The requirement is subject to the provisions of the North American Free Trade Agreement (NAFTA), and the Canadian Free Trade Agreement (CFTA).

## **PART 2 - BIDDER INSTRUCTIONS**

### **2.1 Standard Instructions, Clauses and Conditions**

All instructions, clauses and conditions identified in the bid solicitation by number, date and title are set out in the [Standard Acquisition Clauses and Conditions Manual](https://buyandsell.gc.ca/policy-and-guidelines/standard-acquisition-clauses-and-conditions-manual) (<https://buyandsell.gc.ca/policy-and-guidelines/standard-acquisition-clauses-and-conditions-manual>) issued by Public Works and Government Services Canada.

Bidders who submit a bid agree to be bound by the instructions, clauses and conditions of the bid solicitation and accept the clauses and conditions of the resulting contract.

The [2003](#) (2017-04-27) Standard Instructions - Goods or Services - Competitive Requirements, are incorporated by reference into and form part of the bid solicitation.

- a) Section 02, Procurement Business Number is deleted in its entirety.
- b) Section 20, Further Information is deleted in its entirety.

#### **2.1.1 SACC Manual Clauses**

[B1000T](#) (2014-06-26), Condition of Material – Bid

### **2.2 Submission of Bids**

Bids must be submitted only to Public Works and Government Services Canada (PWGSC) Bid Receiving Unit by the date, time and place indicated on page 1 of the bid solicitation.

### **2.3 Enquiries - Bid Solicitation**

All enquiries must be submitted in writing to the Contracting Authority no later than 3 calendar days before the bid closing date. Enquiries received after that time may not be answered. Bidders should reference as accurately as possible the numbered item of the bid solicitation to which the enquiry relates. Care should be taken by Bidders to explain each question in sufficient detail in order to enable Canada to provide an accurate answer. Technical enquiries that are of a proprietary nature must be

---

clearly marked "proprietary" at each relevant item. Items identified as "proprietary" will be treated as such except where Canada determines that the enquiry is not of a proprietary nature. Canada may edit the question(s) or may request that the Bidder do so, so that the proprietary nature of the question(s) is eliminated, and the enquiry can be answered to all Bidders. Enquiries not submitted in a form that can be distributed to all Bidders may not be answered by Canada.

## 2.4 Applicable Laws

Any resulting contract must be interpreted and governed, and the relations between the parties determined, by the laws in force in Ontario.

Bidders may, at their discretion, substitute the applicable laws of a Canadian province or territory of their choice without affecting the validity of their bid, by deleting the name of the Canadian province or territory specified and inserting the name of the Canadian province or territory of their choice. If no change is made, it acknowledges that the applicable laws specified are acceptable to the Bidders.

## PART 3 - BID PREPARATION INSTRUCTIONS

### 3.1 Bid Preparation Instructions

Canada requests that Bidders provide their bid in separately bound sections as follows:

Section I: Technical Bid (1 hard copy)

Section II: Financial Bid (1 hard copy)

Section III: Certifications (1 hard copy)

Prices must appear in the financial bid only. No prices must be indicated in any other section of the bid.

Canada requests that Bidders follow the format instructions described below in the preparation of their bid:

- (a) use 8.5 x 11 inch (216 mm x 279 mm) paper;
- (b) use a numbering system that corresponds to the bid solicitation.

In April 2006, Canada issued a policy directing federal departments and agencies to take the necessary steps to incorporate environmental considerations into the procurement process [Policy on Green Procurement](http://www.tpsgc-pwgsc.gc.ca/ecologisation-greening/achats-procurement/politique-policy-eng.html) (<http://www.tpsgc-pwgsc.gc.ca/ecologisation-greening/achats-procurement/politique-policy-eng.html>). To assist Canada in reaching its objectives, Bidders should:

- 1) use 8.5 x 11 inch (216 mm x 279 mm) paper containing fibre certified as originating from a sustainably-managed forest and containing minimum 30% recycled content; and
- 2) use an environmentally-preferable format including black and white printing instead of colour printing, printing double sided/duplex, using staples or clips instead of cerlox, duotangs or binders.

---

## Section I: Technical Bid

In their technical bid, Bidders should explain and demonstrate how they propose to meet the requirements and how they will carry out the Work.

## Section II: Financial Bid

Bidders must submit their financial bid in accordance with the Basis of Payment.

## Section III: Certifications

Bidders must submit the certifications and additional information required under Part 5.



### 3.1.1 Electronic Payment of Invoices – Bid

If you are willing to accept payment of invoices by Electronic Payment Instruments, complete Annex “C” Electronic Payment Instruments, to identify which ones are accepted.

If Annex “D” Electronic Payment Instruments is not completed, it will be considered as if Electronic Payment Instruments are not being accepted for payment of invoices.

Acceptance of Electronic Payment Instruments will not be considered as an evaluation criterion.

### 3.1.2 Exchange Rate Fluctuation Risk Mitigation

1. The Bidder may request Canada to assume the risks and benefits of exchange rate fluctuations. If the Bidder claims for an exchange rate adjustment, this request must be clearly indicated in the bid at time of bidding. The Bidder must submit form [PWGSC-TPSGC 450](#) , Claim for Exchange Rate Adjustments with its bid, indicating the Foreign Currency Component (FCC) in Canadian dollars for each line item for which an exchange rate adjustment is required.
2. The FCC is defined as the portion of the price or rate that will be directly affected by exchange rate fluctuations. The FCC should include all related taxes, duties and other costs paid by the Bidder and which are to be included in the adjustment amount.
3. The total price paid by Canada on each invoice will be adjusted at the time of payment, based on the FCC and the exchange rate fluctuation provision in the contract. The exchange rate adjustment will only be applied where the exchange rate fluctuation is greater than 2% (increase or decrease).
4. At time of bidding, the Bidder must complete columns (1) to (4) on form [PWGSC-TPSGC 450](#) , for each line item where they want to invoke the exchange rate fluctuation provision. Where bids are evaluated in Canadian dollars, the dollar values provided in column (3) should also be in Canadian dollars, so that the adjustment amount is in the same currency as the payment.
5. Alternate rates or calculations proposed by the Bidder will not be accepted for the purposes of this exchange rate fluctuation provision.

---

## **PART 4 - EVALUATION PROCEDURES AND BASIS OF SELECTION**

### **4.1 Evaluation Procedures**

- (a) Bids will be assessed in accordance with the entire requirement of the bid solicitation including the technical and financial evaluation criteria.
- (b) An evaluation team composed of representatives of Canada will evaluate the bids.

#### **4.1.1 Technical Evaluation**

##### **4.1.1.1 Mandatory Technical Criteria**

- a) Bidders must indicate the Part Number and the NSCM/NCAGE they are offering.
- b) Bidders proposing an Equivalent or Substitute Product must indicate the brand name and model and/or Part Number and the NSCN/NCAGE

##### **4.1.1.2 Equivalent Products**

1. Products that are equivalent in form, fit, function and quality to the item(s) specified in the bid solicitation will be considered where the Bidder:
  - a. designates the brand name, model and/or part number of the substitute product;
  - b. states that the substitute product is fully interchangeable with the item specified;
  - c. provides complete specifications and descriptive literature for each substitute product;
  - d. provides compliance statements that include technical specifics showing the substitute product meets all mandatory performance criteria that are specified in the bid solicitation; and
  - e. clearly identifies those areas in the specifications and descriptive literature that support the substitute product's compliance with any mandatory performance criteria.
2. Products offered as equivalent in form, fit, function and quality will not be considered if:
  - a. the bid fails to provide all the information requested to allow the Contracting Authority to fully evaluate the equivalency of each substitute product; or
  - b. the substitute product fails to meet or exceed the mandatory performance criteria specified in the bid solicitation for that item.
3. In conducting its evaluation of the bids, Canada may, but will have no obligation to, request bidders offering a substitute product to demonstrate, at the sole cost of bidders, that the substitute product is equivalent to the item specified in the bid solicitation.

##### **4.1.1.3 Substitute Products – Replaced Part Numbers from the OEM**

Products that are replaced part numbers (superseded or obsolete) from the Original Equipment Manufacturer (OEM) must be equivalent in form, fit, function, quality and performance to the original item(s) specified in the bid solicitation and will be considered where the bidder provides:

- a) Proof by submitting a copy of a Certificate of Conformity from the OEM providing justification/explanation that the part numbers are a replacement of the OEM parts specified herein and are equivalent in form, fit, function, quality and performance to the OEM's parts

---

specified herein; or

- b) All required technical information to demonstrate their technical compliance and to confirm form, fit, function, quality and performance of these replaced part numbers.

In conducting its evaluation of the bids, Canada may, but will have no obligation to, request bidders offering a substitute product to demonstrate, at the sole cost of the bidder(s), that the substitute product is equivalent to the item specified in the bid solicitation. If the Bidder fails to provide the requested information within three (3) business days, Canada may declare the bid non-responsive.

#### **4.1.2 Financial Evaluation**

*SACC Manual Clause [A0222T](#) (2014-06-26), Evaluation of Price – Canadian / Foreign Bidders*

#### **4.2 Basis of Selection – Mandatory Technical Criteria**

*SACC Manual Clause [A0031T](#) (2010-08-16), Basis of Selection - Mandatory Technical Criteria*

### **PART 5 – CERTIFICATIONS AND ADDITIONAL INFORMATION**

Bidders must provide the required certifications and additional information to be awarded a contract.

The certifications provided by Bidders to Canada are subject to verification by Canada at all times. Unless specified otherwise, Canada will declare a bid non-responsive, or will declare a contractor in default if any certification made by the Bidder is found to be untrue whether made knowingly or unknowingly, during the bid evaluation period or during the contract period the Contracting Authority will have the right to ask for additional information to verify the Bidder's certifications. Failure to comply and to cooperate with any request or requirement imposed by the Contracting Authority will render the bid non-responsive or constitute a default under the Contract.

#### **5.1 Certifications Required with the Bid**

Bidders must submit the following duly completed certifications as part of their bid.

##### **5.1.1 Integrity Provisions - Declaration of Convicted Offences**

In accordance with the Integrity Provisions of the Standard Instructions, all bidders must provide with their bid, **if applicable**, the declaration form available on the [Forms for the Integrity Regime](http://www.tpsgc-pwgsc.gc.ca/ci-if/declaration-eng.html) website (<http://www.tpsgc-pwgsc.gc.ca/ci-if/declaration-eng.html>), to be given further consideration in the procurement process.

##### **5.2 Certifications Precedent to Contract Award and Additional Information**

The certifications and additional information listed below should be submitted with the bid, but may be submitted afterwards. If any of these required certifications or additional information is not completed and submitted as requested, the Contracting Authority will inform the Bidder of a time frame within which to provide the information. Failure to provide the certifications or the additional information listed below within the time frame provided will render the bid non-responsive.

## 5.2.1 Integrity Provisions – Required Documentation

In accordance with the section titled Information to be provided when bidding, contracting or entering into a real procurement agreement of the [Ineligibility and Suspension Policy](http://www.tpsgc-pwgsc.gc.ca/ci-if/politique-policy-eng.html) (<http://www.tpsgc-pwgsc.gc.ca/ci-if/politique-policy-eng.html>), the Bidder must provide the required documentation, as applicable, to be given further consideration in the procurement process.

## 5.2.2 Federal Contractors Program for Employment Equity - Bid Certification

By submitting a bid, the Bidder certifies that the Bidder, and any of the Bidder's members if the Bidder is a Joint Venture, is not named on the Federal Contractors Program (FCP) for employment equity "FCP Limited Eligibility to Bid" list available at the bottom of the page of the [Employment and Social Development Canada \(ESDC\) - Labour's](https://www.canada.ca/en/employment-social-development/programs/employment-equity/federal-contractor-program.html#) website (<https://www.canada.ca/en/employment-social-development/programs/employment-equity/federal-contractor-program.html#>).

Canada will have the right to declare a bid non-responsive if the Bidder, or any member of the Bidder if the Bidder is a Joint Venture, appears on the "FCP Limited Eligibility to Bid" list at the time of contract award.

## PART 6 - RESULTING CONTRACT CLAUSES

The following clauses and conditions apply to and form part of any contract resulting from the bid solicitation.

### 6.1 Security Requirements

There is no security requirement applicable to the Contract.

### 6.2 Requirement

The Contractor must provide the items detailed under the "Line Item Details" at Annex "A".

### 6.3 Standard Clauses and Conditions

All clauses and conditions identified in the Contract by number, date and title are set out in the [Standard Acquisition Clauses and Conditions Manual](https://buyandsell.gc.ca/policy-and-guidelines/standard-acquisition-clauses-and-conditions-manual) (<https://buyandsell.gc.ca/policy-and-guidelines/standard-acquisition-clauses-and-conditions-manual>) issued by Public Works and Government Services Canada.

#### 6.3.1 General Conditions

[2010A](#) (2016-04-04), General Conditions - Goods (Medium Complexity), apply to and form part of the Contract.

a. Definition of Minister is modified as follows:

"Canada", "Crown", "Her Majesty" or "the Government" means Her Majesty the Queen in right of Canada as represented by the Minister of National Defence and any other person duly authorized to act on behalf of that minister or, if applicable, an appropriate minister to whom the Minister of National Defence has delegated his or her powers, duties or functions



and any other person duly authorized to act on behalf of that minister

## **6.4 Term of Contract**

### **6.4.1 Period of the Contract**

The period of the Contract is from date of Contract award to the end of the warranty period as described in Section 09 of 2010A (2016-04-04) General Conditions - Goods (Medium Complexity).

### **6.4.2 Delivery Date**

All the deliverables must be received on or before \_\_\_\_\_.

DND reserves the right to negotiate delivery date changes to before or after March 31, 2019.

### **6.4.3 Delivery Points**

Delivery of the requirement will be made to delivery point(s) specified at Annex "A" of the Contract.

## **6.5 Authorities**

### **6.5.1 Contracting Authority**

The Contracting Authority for the Contract is:

Name: Nashveen Mendes  
Title: D Mar P 4-3-2-2  
Directorate: DGMEPM  
Address: 101 Colonel By Drive, Ottawa, Ontario, K1A 0K2  
E-mail address: Nashveen.mendes@forces.gc.ca

The Contracting Authority is responsible for the management of the Contract and any changes to the Contract must be authorized in writing by the Contracting Authority. The Contractor must not perform work in excess of or outside the scope of the Contract based on verbal or written requests or instructions from anybody other than the Contracting Authority.

### **6.5.2 Technical Authority**

The Technical Authority for the Contract is:

Name: \_\_\_\_\_  
Title: \_\_\_\_\_  
Organization: \_\_\_\_\_  
Address: \_\_\_\_\_  
Telephone: \_\_\_\_ - \_\_\_\_ - \_\_\_\_  
Facsimile: \_\_\_\_ - \_\_\_\_ - \_\_\_\_  
E-mail: \_\_\_\_\_.

The Technical Authority named above is the representative of the department or agency for whom the Work is being carried out under the Contract and is responsible for all matters concerning the technical content of the Work under the Contract. Technical matters may be discussed with the Technical Authority, however the Technical Authority has no authority to authorize changes to the scope of the Work. Changes to the scope of the Work can only be made through a contract amendment issued by the Contracting Authority.

### 6.5.3 Contractor's Representative

Name: \_\_\_\_\_  
Title: \_\_\_\_\_  
Organization: \_\_\_\_\_  
Address: \_\_\_\_\_

Telephone: \_\_\_\_\_  
Facsimile: \_\_\_\_\_  
E-mail address: \_\_\_\_\_

## 6.6 Payment

### 6.6.1 Basis of Payment – Firm Price

In consideration of the Contractor satisfactorily completing all of its obligations under the Contract, the Contractor will be paid firm price, as specified in Annex B. Customs duties are included and Applicable Taxes are extra.

Canada will not pay the Contractor for any design changes, modifications or interpretations of the Work, unless they have been approved, in writing, by the Contracting Authority before their incorporation into the Work.

### 6.6.2 Limitation of Price

SACC Manual clause [C6000C](#) (2017-08-17), Limitation of Price

### 6.6.3 Terms of Payment

SACC Manual clause [H1001C](#) (2008-05-12), Multiple Payments

SACC Manual clause [C2000C](#) (2007-11-30), Taxes – Foreign-based Contractor

### 6.6.4 Electronic Payment of Invoices – Contract

The Contractor accepts to be paid using any of the following Electronic Payment Instrument(s):

- a. Direct Deposit (Domestic and International);
- b. Electronic Data Interchange (EDI);
- c. Wire Transfer (International Only);

## 6.7 Invoicing Instructions

The Contractor must submit invoices in accordance with the section entitled "Invoice Submission" of the general conditions. Invoices cannot be submitted until all work identified in the invoice is completed.

Invoices must be distributed as follows:

- a) The original and one (1) copy must be forwarded to the following address for certification and payment.

---

Department of National Defence  
Maritimes Forces Atlantic  
Accts Payable Bldg. S-90, Room 334 2686  
Sextant Lane, Stadacona  
PO Box 99000 Stn Forces  
Halifax, NS B3K 5X5 Canada

and

Department of National Defence  
Base Logistics Officer  
CFB Esquimalt  
STN Forces, P.O. Box 17000  
Victoria, BC V9A 7N2 Canada

b) One (1) copy must be forwarded to:

Department of National Defence  
101 Colonel By Drive  
Ottawa, Ontario K1A 0K2  
Attn: D Mar P 4-3-2-2

## **6.8 Certifications and Additional Information**

### **6.8.1 Compliance**

Unless specified otherwise, the continuous compliance with the certifications provided by the Contractor in its bid or precedent to contract award, and the ongoing cooperation in providing additional information are conditions of the Contract and failure to comply will constitute the Contractor in default. Certifications are subject to verification by Canada during the entire period of the Contract.

### **6.9 Applicable Laws - Contract**

The Contract must be interpreted and governed, and the relations between the parties determined, by the laws in force in Ontario.

### **6.10 Priority of Documents**

If there is a discrepancy between the wording of any documents that appear on the list, the wording of the document that first appears on the list has priority over the wording of any document that subsequently appears on the list.

- a) the Articles of Agreement;
- b) the general conditions [2010A](#) (2016-04-04), General Conditions - Goods (Medium Complexity)
- c) Annex A, Line Item Details
- d) Annex B, Basis of Payment
- e) Annex C, Long Text Description
- f) the Contractor's bid dated\_\_\_\_\_.

### **6.11 Defence Contract**

---

SACC *Manual* clause [A9006C](#) (2012-07-16) Defence Contract

## 6.12 SACC *Manual* Clauses

[B7500C](#) (2006-06-16), Excess Goods

[D2001C](#) (2007-11-30), Labelling

[D2000C](#) (2007-11-30), Marking

[D2025C](#) (2017-08-17), Wood Packaging Materials

[D6010C](#) (2007-11-30), Palletization

[G1005C](#) (2016-01-28), Insurance - No Specific Requirement

## 6.13 Asbestos

The contractor shall not use asbestos in the equipment unless no feasible alternative is available, in which case rationale shall be provided. Any parts containing asbestos shall be properly labelled, and the part number and location be explicitly identified in technical documentations.

## 6.14 Packaging Requirements using Specification D-LM-008-036/SF-000

The Contractor must prepare all line items for delivery in accordance with the latest issue of the Canadian Forces Packaging Specification D-LM-008-036/SF-000, DND Minimum Requirements for Manufacturer's Standard Pack.

The Contractor must package all line items in quantities of 1 by package.

## 6.15 Quality Assurance

SACC *Manual* clause D5545C (2010-08-16) ISO 9001:2008 – Quality Management Systems – Requirements (Quality Assurance Code C)

## 6.16 Shipping Instructions - Delivery and Destination Schedules Unknown

1. The Contractor must ship the goods prepaid DDP - Delivered Duty Paid (... named place of destination). Unless otherwise directed, delivery must be made by the most economical means. Shipping charges must be shown as a separate item on the Contractor's invoice. The Contractor is responsible for all delivery charges, administration, costs and risks of transport and customs clearance, including the payment of customs duties and Applicable Taxes.
2. The Contractor must deliver the goods to Canadian Forces (CF) Supply Depots by appointment only. The Contractor or its carrier must arrange delivery appointments by contacting the Depot Traffic Section at the appropriate location shown below. The consignee may refuse shipments when prior arrangements have not been made.
  - a) 2B1 CF Esquimalt  
Esquimalt, B.C.

---

Telephone: 250-363-4963

b) 7H1 CF Halifax  
Halifax, N.S.  
Telephone: 902-427-1441

## 6.17 Exchange rate fluctuation adjustment

1. The foreign currency component (FCC) is defined as the portion of the price or rate that will be directly affected by exchange rate fluctuation. The FCC should include all related taxes, duties and other costs paid by the Bidder and which are to be included in the adjustment amount.
2. For each line item where a FCC is identified, Canada assumes the risks and benefits for exchange rate fluctuation, as shown in the Basis of Payment. For such items, the exchange rate fluctuation amount is determined in accordance with the provision of this clause.
3. The total price paid by Canada on each invoice will be adjusted at the time of payment. The exchange rate adjustment amount will be calculated in accordance with the following formula:  
Exchange rate adjustment =  $FCC \times Qty \times (i_1 - i_0) / i_0$   
where formula variables correspond to:

### FCC

Foreign currency component (per unit)

### Qty

quantity of units

$i_0$  Initial exchange rate (CAN\$ per unit of foreign currency [for example US\$1]).  
The initial exchange rate is set as the Bank of Canada rate on the solicitation closing date. The Bank of Canada publishes its rates each business day by 16:30 Eastern Time.

$i_1$  Exchange rate for adjustments (ERA) (CAN\$ per unit of foreign currency [for example US\$1]). The Bank of Canada publishes its rates each business day by 16:30 Eastern Time.

- a. The ERA for goods will be the Bank of Canada rate on the date the goods were delivered.
  - b. The ERA for services will be the Bank of Canada rate on the last business day of the month for which the services were performed.
  - c. The ERA for advance payments will be the Bank of Canada rate on the last business day prior to the payment. The last published business day rate will be used for non-business days.
4. The Contractor must indicate the total exchange rate adjustment amounts (whether they are upward, downward or present no change) as a separate item on each invoice or claim for payment submitted under the Contract. Where an adjustment applies, the Contractor must submit with their invoice form [PWGSC-TPSGC 450](#),  Claim for Exchange Rate Adjustments.
  5. The exchange rate adjustment will only impact the payment to be made by Canada where the exchange rate fluctuation is greater than 2% (increase or decrease), calculated in accordance

Solicitation No. - N° de l'invitation

W8482-194309/A

Client Ref. No. - N° de réf. du client

Amd. No. - N° de la modif.

File No. - N° du dossier

Buyer ID - Id de l'acheteur

24A

CCC No./N° CCC - FMS No./N° VME

---

with column 8 of form [PWGSC-TPSGC 450](#)  (that is  $[ i_1 - i_0 ) / i_0 ]$ ).

6. Canada reserves the right to audit any revision to costs and prices under this clause.

**ANNEX A LINE ITEM DETAILS**

Item	Description	Unit of Issue	Quantity	Destination Address	Invoice Address	Security Requirement	Quality Assurance Code (QAC)	Controlled Goods (CTAT or ITAR)	Trade Agreement
001	NSN: 5340-21-001-3732 Item Name: ANODE, CORROSION PREVENTIVE P/N requested: 5340STD137 NSCM/MFG: 36294 DGMEPM See Annex C for Specifications  OR EQUIVALENT If offering an equivalent specify: P/N offered: _____  NCAGE _____	EA	500	Formation Commander HMC Dockyard Bldg D206 Door 1 thru 13 Halifax, NS B3K 5X5 Canada	Accounts Payable Dept. Of National Defence Maritime Forces Atlantic P.O. Box 99000, Stn Forces Halifax NS B3K 5X5 CANADA	NO	C	NO	CFTA NFTA
002	NSN: 5340-21-001-3732 Item Name: ANODE, CORROSION PREVENTIVE P/N requested: 5340STD137 NSCM/MFG: 36294 DGMEPM See Annex C for Specifications  OR EQUIVALENT If offering an equivalent specify: P/N offered: _____  NCAGE: _____	EA	500	Base Commander CFB Esquimalt Bldg 66 Colwood Victoria, BC V9A 7N2 Canada	Accounts Payable Dept. of National Defence Base Logistics Officer CFB Esquimalt P.O. Box 17000, Stn Forces Victoria, BC V9A 7N2 Canada	NO	C	NO	CFTA NFTA

**ANNEX B BASIS OF PAYMENT**

Item	Description	Unit of Issue	Quantity	Destination Address	Invoice Address	FIRM UNIT PRICE: Delivered Duty Paid (DDP), Transportation costs included, Applicable taxes extra	EXTENDED PRICE: Applicable taxes extra	Applicable taxes	TOTAL PRICE: Applicable taxes Included
001	NSN: 5340-21-001-3732  Item Name: ANODE, CORROSION PREVENTIVE  P/N requested: 5340STD137  NSCM/MFG: 36294 DGMEPM	EA	500	Formation Commander HMC Dockyard Bldg D206 Door 1 thru 13 Halifax, NS B3K 5X5 Canada	Accounts Payable Dept. Of National Defence Maritime Forces Atlantic P.O. Box 99000, Stn Forces Halifax NS B3K 5X5 CANADA				
002	NSN: 5340-21-001-3732  Item Name: ANODE, CORROSION PREVENTIVE  P/N requested: 5340STD137  NSCM/MFG: 36294 DGMEPM	EA	500	Base Commander CFB Esquimalt Bldg 66 Colwood Victoria, BC V9A 7N2 Canada	Accounts Payable Dept. of National Defence Base Logistics Officer CFB Esquimalt P.O. Box 17000, Stn Forces Victoria, BC V9A 7N2 Canada				
<b>TOTAL</b>									



**ANNEX C: LONG TEXT DESCRIPTION**

**Line items 001 – 002**

**NSN: 5340-21-001-3732**

**ITEM NAME: ANODE CORROSION PREVENTIVE**

<b>Characteristic</b>	<b>Reply</b>
<b>MATERIAL AND LOCATION</b>	MAGNESIUM ALLOY ANODE
<b>OUTSIDE DIAMETER</b>	6.016 INCHES NOMINAL
<b>THICKNESS</b>	4.016 INCHES NOMINAL
<b>WEIGHT</b>	6.0 POUNDS
<b>SPECIAL FEATURES</b>	ROUND TYPE; 0.625-18UNF-3B THD MOUNTING ASSEMBLY

LIST OF MATERIAL

PC No.	DESCRIPTION	QTY.	MATERIAL	MATERIAL SPEC.	FINISH	NAV. CAT.
MAGNESIUM ANODE ASSEMBLY NAV. CAT. 5340-001-3732						
MAGNESIUM ANODE ASSY.						
1	ANODE MK V TYPE A	1	MAG. ALLOY	COMM.	SEE NOTES 15 & 17	5340-21-001-3732
2	CROSS PIECE SUPPORT	1	STEEL	COMM.	SEE NOTE 2	
3	NUT, 5/8-18 AMER. STD. HEX. (SEMI. FIN.)	1	STEEL	COMM.	SEE NOTE 2	
RESISTOR MOUNTING ASSEMBLY NAV. CAT. 2040-001-3733						
4	LOCK WASHER, 5/8 X 13/64 X 3/32, S.A.E. STD.	1	STEEL	COMM.	ZINC	
5	JAM NUT, 5/8-18 AMER. STD. HEX. (SEMI. FIN.)	1	STEEL	COMM.	SEE NOTE 5	2040-21-797-4286
6	WASHER, 2 1/32 I.D. & 5/16 O.D. .095 THK.	1	BRASS			
7	ANODE RESISTANCE WASHER MK 1.	NOT SUPPLIED	EEC-STD-138			5905-442-1715
8	MOUNTING PLATE	1	STEEL	SAE 1010-1020		
9	CAP SCREW, 5/8-18, AMER. STD. F.H.M. (SEMI. FIN.)	1	STEEL	COMM.	SEE NOTE 6	
10	PLATE	1	STEEL	SAE 1010-1020	SEE NOTE 19	
**	11	INSULATION	1	POLYVINYL CHLORIDE MELT MIX	MIL-R-900	

\*\* MIL-R-900 EXCEPT WAIVE REQUIREMENT FOR:  
(A) HARDNESS BEFORE AGING, PARA 3-7.1.  
(B) ULTIMATE ELONGATION AFTER AGING.  
(C) COMPRESSION SET.  
(D) SEAL TEST AGED.

NOTES:

1. \_\_\_\_\_
2. AFTER WELDING TOGETHER, PCS 2 & 3 TO BE ELECTRIC ZINC PLATED IN ACCORDANCE WITH ASTM SPECIFICATION B633-98e1. PLATING SHALL BE A MINIMUM OF 5 MICROMETRES IN THICKNESS.
3. RESISTANCE TO BE DEMANDED SEPARATELY FOR EACH APPLICATION.
4. THE SURFACE OF THE MOUNTING PLATE, PC. 8 WHERE ACTING AS CONTACT SURFACE FOR EEC-STD-138 SHALL BE TINNED TO ENSURE GOOD ELECTRICAL CONNECTION.
5. THE WELDING OF THE JAM NUT (PC. 5) TO THE BRASS WASHER (PC. 6) TO BE DONE BY THE MANUFACTURER, WITH SILVER SOLDER.
6. PC. NO. 9 MACHINED FROM AMER. STD. CAP SCREW.
7. SURFACES OF PC. NO. 8 & 10 TO BE THOROUGHLY CLEANED AND PREPARED BEFORE APPLYING INSULATION AND CEMENTING.
8. AFTER CASTING MAGNESIUM ANODE TO BE HOT-DIPPED IN POLYVINYL CHLORIDE CAPSULATING COMPOUND TO A THICKNESS OF 1/16. A PRIMER SHOULD BE USED TO ENSURE AN ADEQUATE BOND STRENGTH.
9. THE CAPSULATING COMPOUND SHALL HAVE A MINIMUM PEEL STRENGTH OF 10 LBS. PER INCH WIDTH.
10. EDGE OF CENTRE HOLE SHALL BE ROUNDED AND FREE OF BURRS. OUTER EDGE OF PLATE SHALL BE FREE OF BURRS.
11. ALL PARTS SHALL BE POSITIONED BY JIG WHILE WELDING TO INSURE PROPER ALIGNMENT.
12. ALL SHARP EDGES SHALL BE SLIGHTLY ROUNDED.
13. A LABEL SHALL BE PROVIDED ON THE UNIT GIVING THE MANUFACTURER'S NAME OR INITIALS NOT LESS THAN 1/4" HIGH. THIS IDENTIFICATION LABEL SHALL BE THAT OF THE PRIME MANUFACTURER RESPONSIBLE FOR FINAL ACCEPTANCE OF THE EQUIPMENT. THE LABEL SHALL ALSO INCLUDE THE APPLICABLE STOCK NUMBER, DRAWING NUMBER, TYPE NUMBER AND DATE OF MANUFACTURE.
14. THE ADEQUATE STRENGTH OF WELDED COMPONENTS SHALL BE DETERMINED FROM PERIODIC CHECKS ON PRODUCTION SAMPLES BY SUBJECTING THE WELDED PIECES TO DIRECT IMPACT BLOWS OF A HAMMER SUFFICIENT TO COMPLETELY BEND, DISTORT OR CRUSH THE WELDED PIECES WITHOUT THEIR BEING TORN APART.
15. CASTINGS SHALL BE FREE FROM COLD SHOTS, BLOW HOLES, OR ANY IMPERFECTIONS THAT MAY AFFECT THE STRENGTH IN ANY WAY. ALL SURFACES OF CASTINGS SHALL HAVE ALL FINIS AND BURRS REMOVED. SAND SURFACES SHALL BE DISTURBED AS LITTLE AS POSSIBLE.
16. BEFORE SHIPMENT ON AN ORIGINAL CONTRACT (i.e. MANUFACTURER HAS NOT PROVIDED AN ACCEPTABLE PRODUCT PREVIOUSLY), TWO PRE-PRODUCTION SAMPLES ARE TO BE FORWARDED BY THE MANUFACTURER TO THE TECHNICAL AUTHORITY.

GENERAL ASSEMBLY

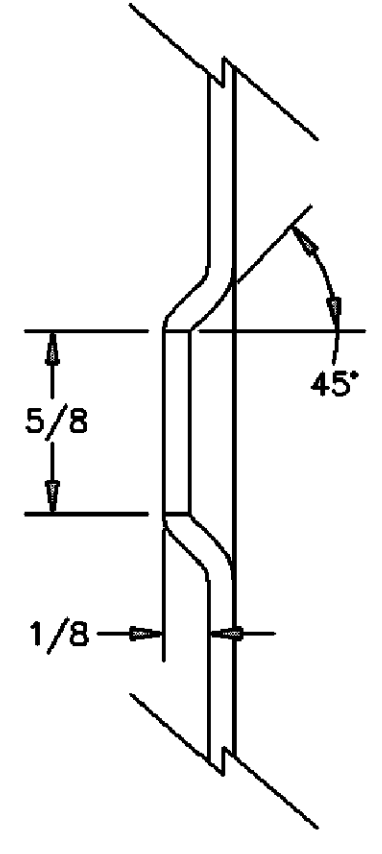
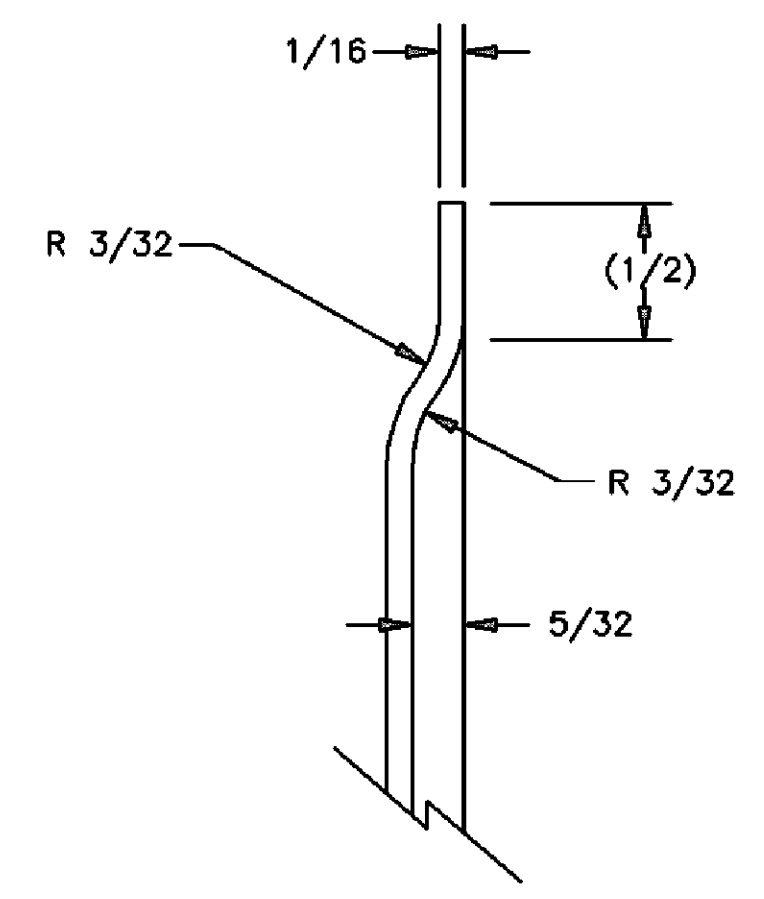
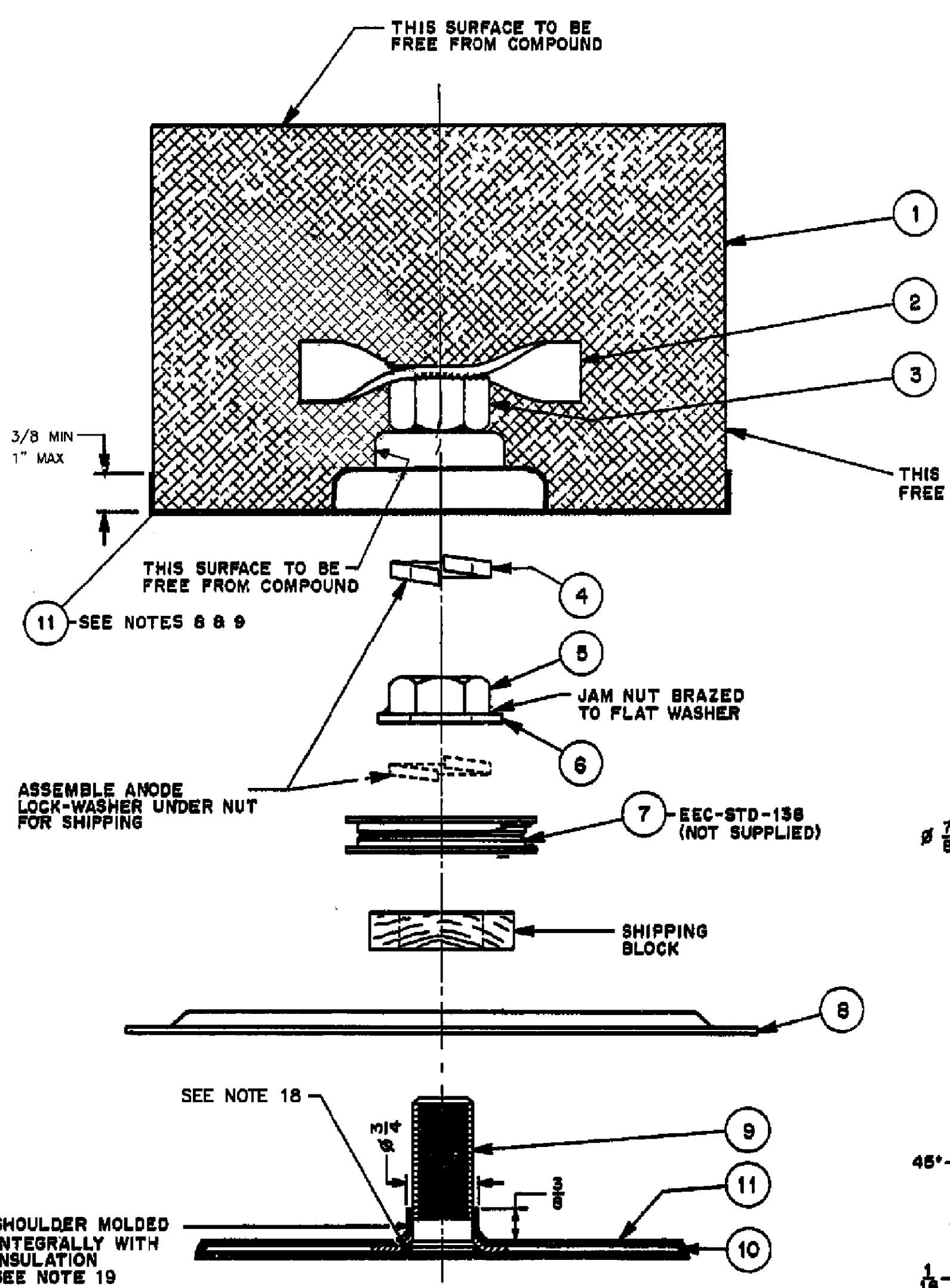

DETAIL B  
SCALE NTS

DETAIL A  
SCALE NTS

SHIPPING BLOCK

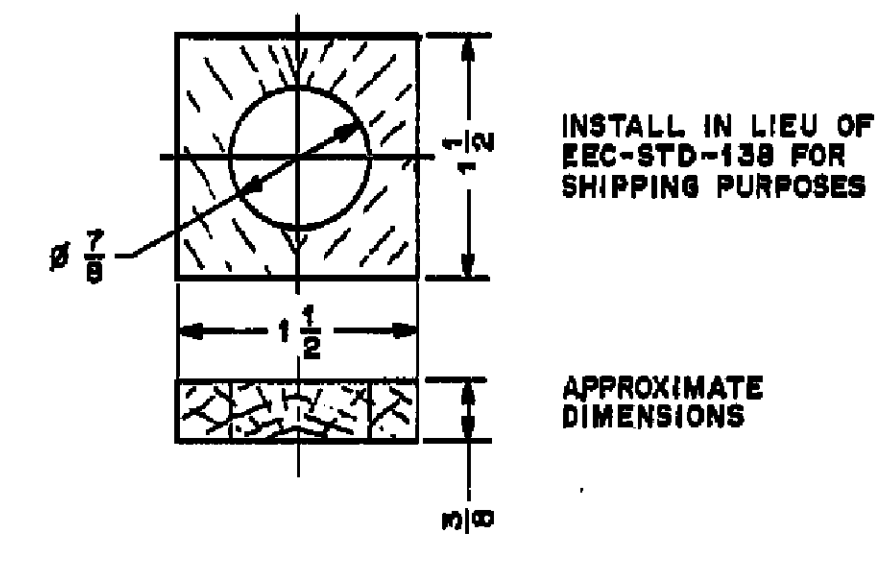

17. THE MAGNESIUM ALLOY SHALL BE TYPE AZ63B IN ACCORDANCE WITH ASTM SPECIFICATION B843-93 (1998). THE MANUFACTURER SHALL CONFIRM THIS IN THEIR TENDER RESPONSE.
18. PIECES 9 & 10 SHALL BE WELDED TOGETHER, WITH PIECE 9 WITHIN 2 DEGREES OF PERPENDICULAR TO PIECE 10. ALL WELDING FLASH AND ROUGH EDGES SHALL BE REMOVED SO AS TO AVOID PUNCTURING THE INSULATION.
19. THE INSULATING COMPOUND (POLYVINYL CHLORIDE 20 TO 45 DUROMETER HARDNESS BEFORE AGING) COATING THE PIECE 9 & 10 ASSEMBLY SHALL BE APPROXIMATELY 3/4 INCHES THICK, TOP & BOTTOM SUCH THAT THE COMPLETED ASSEMBLY SITS FLUSH UNDER PIECE 8. THIS WILL ALLOW THE COMPLETED ASSEMBLY (NOTE 20) TO BE WELDED TO THE VESSEL'S HULL PLATING.
20. AFTER FINAL COMPLETION OF PIECES 8, 9 & 10, THEY ARE TO BE SUITABLY CLEANED, ALIGNED AND THEN SECURELY GLUED TOGETHER USING LOCTITE BONDING COMPOUND E-300L OR EQUIVALENT. IN ORDER TO GET A TIGHT FIT BETWEEN THE TWO SURFACES, IT MAY BE NECESSARY TO ENLARGE THE HOLE IN PIECE 8 SO THAT THE INSULATION ON THE SHOULDER OF THE BOLT PIECE 9, FITS CLEANLY THROUGH THE HOLE.
21. AFTER THE PIECES HAVE BEEN GLUED TOGETHER, PLACE THE "SHIPPING BLOCK" ON THE STUD, ADD THE LOCK WASHER AND THEN PUT THE "JAM NUT/WASHER" ASSEMBLY ON FINGER TIGHT, WITH A MEGGER (250 OR 500 VOLTS), MEASURE THE INSULATION RESISTANCE BETWEEN THE STUD AND THE "MOUNTING PLATE" (PIECE 8). THE RESISTANCE SHALL BE AT LEAST 10 MEGOHMS, OTHERWISE THE ASSEMBLY IS NOT ACCEPTABLE.

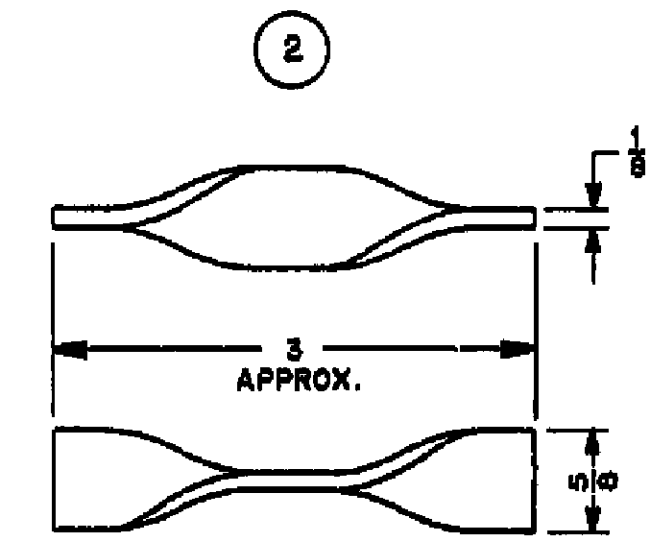

SECTION X-X

MAGNESIUM ANODE

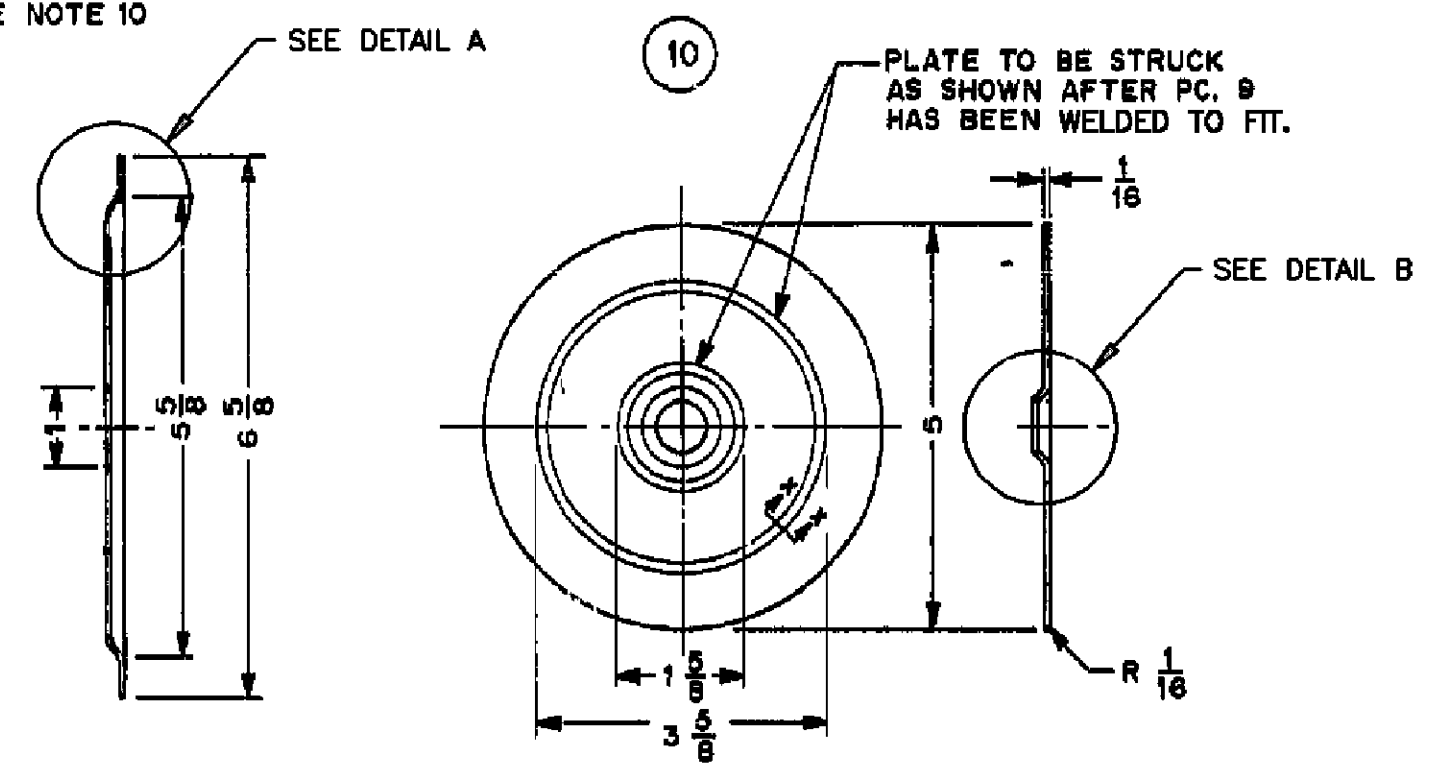
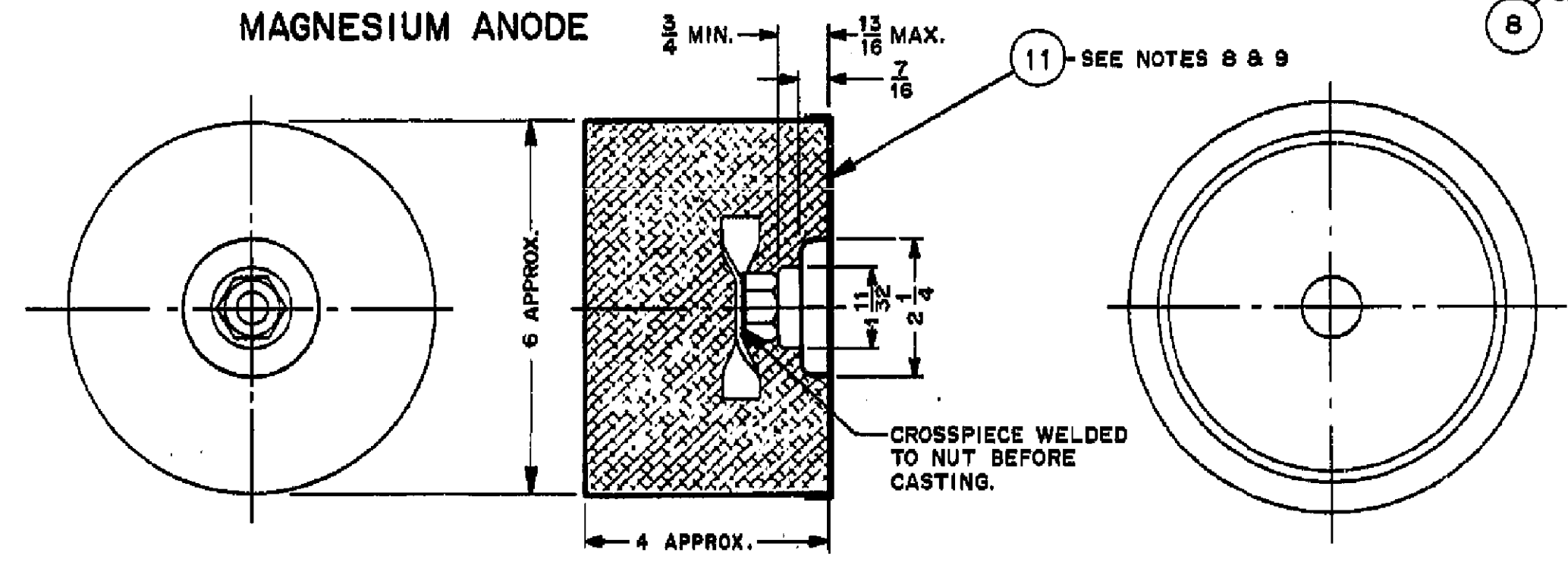

TOLERANCES UNLESS SPECIFIED OTHERWISE	SEE TABLE BELOW FOR SECURITY CLASSIFICATION OF DRAWING	NO.	REVISIONS	DATE	BY
DECIMALS ± .005	<b>SECURITY RATING</b> TOP SECRET -SECRET CONFIDENTIAL RESTRICTED UNCLASSIFIED REFERENCE DRAWING	14	TDAN 084571026	09-01-26	AT
FRACTIONS ± 1/64		13	TDAN 034570031	03-12-04	AT
ANGLES ± 1/2		12	TDAN 024570027	03-02-28	AT
DIMENSIONS ARE IN INCHES		11	TDAN 934570038	93-09-20	SC
TOLERANCES MUST NOT BE ACCUMULATIVE		10	TDAN 874570020	87-12-17	AT
			NAVY HEADQUARTERS DIRECTOR GENERAL SHIPS MK. V MAGNESIUM ALLOY ANODE & RESISTOR MOUNTING TYPE A DRN. <i>[Signature]</i> TOD. <i>[Signature]</i> GAGNON SC. CKD. <i>[Signature]</i> APD. <i>[Signature]</i> DATE <i>[Signature]</i> 1. 1987. SHT. OF 1 DWG. NO. 5340STD.137		

REPLACES REVISION '9' WITH CHANGES

## ANNEX D TO PART 3 OF THE BID SOLICITATION

### ELECTRONIC PAYMENT INSTRUMENTS

The Bidder accepts any of the following Electronic Payment Instrument(s):

- Direct Deposit (Domestic and International)
- Electronic Data Interchange (EDI)
- Wire Transfer (International Only)