



Agriculture and Agri-Food Canada (AAFC)

Project Title:

REPAIR OF THE SLATS OF THE SLATTED FLOORS IN ROOMS C-101, C-102 AND
C-103 OF THE SWINE COMPLEX

Sherbrooke Research and Development Centre
2000 College Street, Sherbrooke, Quebec J1M 0C8

Tenders **must** be **received** by: 2:00 PM, Eastern Daylight Time

On **June 21, 2018** at the following address:

Agriculture and Agri-Food Canada

Corporate Management Branch
Assets Team – Eastern Service Centre

TENDER RECEIVING UNIT

2001 Robert-Bourassa Blvd., Suite 671-TEN
Montreal, QC
H3A 3N2

**Note: Tenders received at a location other than this one
will be rejected.**



Table of Contents

Part I	Additional Instructions
Appendix A	Instructions to Bidders (AAFC/AAC5319)
Appendix B	Special Instructions to Bidders (AAFC/AAC5318)
Appendix C	Bid and Acceptance Form (AAFC/AAC5312)
Appendix D	General Conditions for Minor Works (AAFC/AAC5316)
Appendix E	Plans & Technical Specifications
Appendix F	Insurance Terms (AAFC/AAC5315)
Appendix G	Form A - Subcontracting



PART I. ADDITIONAL INSTRUCTIONS

AI 1. Definitions

- *Tenderers/Bidders*: Individual or Firm responding to the request for tender.
- *Contracting Authority*: is the individual within Agriculture and Agri-Food Canada (AAFC) who is responsible of the integrity and the transparency of the competitive tender process. The Contracting Authority is also responsible for the issuance of the contract and any amendment related to it.
- *Project Manager*: is the individual within AAFC who is responsible for all matters concerning the technical content of the Work under the awarded contract.

AI 2. Context

Building 7 is the swine complex of Agriculture and Agri-Food Canada's Sherbrooke Research and Development Centre (Sherbrooke RDC) located at 2000 College Street Sherbrooke, Quebec. It is composed of eight (8) sectors (A to H) built in 1996–1997. Sector C is reserved for sow gestation and comprises four (4) rooms (C-101, C-102, C-103 and C-104), each measuring approximately 15 m x 18 m.

Each room in Sector C has a concrete slatted floor that empties into four (4) channels: one (1) channel along each of the east and west walls of the room and two (2) middle channels in the centre of the room. Each channel is covered with a prefabricated concrete slat floor.

Over time, the foundations of the walls of the channels upon which the prefabricated slats are laid have eroded and the slats are no longer supported all along the length of the channels. The slats are unstable and are no longer level with each other.

AI 3. Optional Site Visit

A site visit is scheduled for **Tuesday, June 12, 2018 at 10:00 AM** (local time) at the Sherbrooke Research and Development Centre located at 2000 College Street, Sherbrooke, QC, J1M 0C8. Tenderers are requested to be present at the reception desk at least 10 minutes prior to the meeting. No other pre-tender meeting will be scheduled during the tender process.

Attendance by interested tenderers is not mandatory.

However, the tenderer has the responsibility to ascertain he/she has knowledge of all the facts and information on the nature and provision of the work requested. Lack of knowledge of the conditions will not be a valid excuse accepted for the inability to satisfactorily meet the services required.

AI 4. Requests for information

All requests for information regarding this call for tenders **MUST** be presented in writing and sent exclusively to the *Contracting Authority* identified below, as soon as possible during the tender period and no later than three (3) working days before the end of this period, in order to allow sufficient time to answer. Inquiries received after that time might not be answered prior to the tender closing date.



Contracting Authority:

Aline Mulinda
Agriculture and Agri-Food Canada
2001 Robert Bourassa blvd., 671 -TEN
Montreal, Quebec, H3A 3N2
Telephone: 514 315-6140
Facsimile: 514 283-1918
Email: aline.mulinda@canada.ca

AI 5. Revision of Tenders (Modification to Clause IB10, Appendix A)

The following paragraph shall be added after paragraph 1) :

“...However, any indication of tender price modification **shall not reveal** the amount of the original or the revised total tender. Any indication of the old or the new total tender will get the often discarded automatically.”

AI 6. Receipt of Tenders

Sealed tenders will be received at the following address:

Agriculture and Agri-Food Canada
Assets Team - Eastern Service Centre
Tender Receiving Unit
2001 Robert-Bourassa blvd., suite 671-TEN
Montreal, Quebec, H3A 3N2

AAFC will not necessarily accept the lowest tender nor any tender, in whole or in part.

AI 7. Presentation of Tenders

Tenderers must submit their tenders, in a sealed envelope marked “Tender - Confidential” as well as the project reference number: **01B46-18-032**

AI 8. Contractual Documents:

The following documents will form part of any resulting contract:

- Appendix C Bid and Acceptance Form (AAFC/AAC5312)
- Appendix D General Conditions for Minor Works (AAFC/AAC5316)
- Appendix E Plans & Technical Specifications
- Appendix F Insurance Terms (AAFC/AAC5315)
- Appendix G Form A - Subcontracting



AI 10. T4-A

The Contractor shall complete and submit this T4-A Certification within fourteen (14) days of Notification of Contract award and within fourteen (14) calendar days immediately following any change to the information already provided under the Contract. Failure to provide this information or failure to provide the correct information shall result a fundamental breach of the Contract.

1. The Contractor shall enter a [x] in one of the boxes below opposite the description that best describe its status.
 - A business incorporated either federally or provincially;
 - An unincorporated business, either as a sole proprietor or a partnership; or
 - An individual.

Note. The information provided in section 2 must correspond with that provided in Section 1.

Corporate or unincorporated
Business or individual's name: _____

Street Name or Box Number: _____

City, Town or Village: _____

Province: _____

Postal Code: _____

E-mail address: _____

2. Contractor shall complete section 2(a) or 2(b) or 2(c), whichever is applicable to its situation.
 - a) If incorporated:

Business Number (BN)	_____ , or
GST/HST Number:	_____ , or
T2 Corporation Tax Number (T2N)	_____ , whichever is applicable
 - b) If unincorporated:

Business Number (BN)	_____ , or
GST/HST Number:	_____ , or
T2 Corporation Tax Number (T2N)	_____ , whichever is applicable

Note: The Unincorporated Business Name must be the same as the name associated with the Revenue Canada Business Number or the GST/HST Number.

- c) If individual:

Business Number (BN)	_____ , or
GST/HST Number:	_____ , or
T2 Corporation Tax Number (T2N)	_____ , whichever is applicable

Note: The Individual's Name must be the same as the name associated with the Social Insurance Number.

3. **WE HEREBY CERTIFY that I/WE have examined the information provided above, including the legal name, address and Revenue Canada identifier (SIN, BN, GST/HST No., T2N), as applicable, and that it is correct and complete, and fully discloses my/our identification.**

Signature of Contractor

Title of Signatory

Date



Appendix "A"

INSTRUCTIONS TO BIDDERS

INSTRUCTIONS TO BIDDERS

IB01	Completion of Bid
IB02	Identity or Legal Capacity of the Bidder
IB03	Applicable Taxes
IB04	Tax to Be Included
IB05	Capital Development and Redevelopment Charges
IB06	Registry and Pre-qualification of Floating Plant
IB07	Listing of Subcontractors and Suppliers
IB08	Bid Security Requirements
IB09	Submission of Bid
IB10	Revision of Bid
IB11	Acceptance of Bid
IB12	Bid Costs
IB13	Compliance with Applicable Laws
IB14	Approval of Alternative Materials
IB15	Income Tax Requirement
IB16	Contingency Fees
IB17	Status of the Bidder
IB18	Integrity Provisions - Bids Over \$10,000.00
IB19	Code of Conduct for Procurement - Bid

IB01 Completion of Bid

- 1) The bid shall be:
 - (a) submitted on the BID AND ACCEPTANCE FORM provided by AAFC or on a clear and legible reproduced copy of such BID AND ACCEPTANCE FORM that must be identical in content and format to the BID AND ACCEPTANCE FORM provided by AAFC;
 - (b) based on the Bid Documents listed in the SPECIAL INSTRUCTIONS TO BIDDERS;
 - (c) correctly completed in all respects;
 - (d) signed, with an original signature, by a duly authorized representative of the Bidder; and
 - (e) accompanied by any other document or documents specified elsewhere in the solicitation where it is stipulated that said documents are to accompany the bid.

- 2) Subject to paragraph 6) of IB11, any alteration to the pre-printed or pre-typed sections of the BID AND ACCEPTANCE FORM, or any condition or qualification placed upon the bid shall be cause for disqualification. Alterations, corrections, changes or erasures made to statements or figures entered on the BID AND ACCEPTANCE FORM by the Bidder shall be initialed by the person or persons signing the bid. Initials shall be original(s). Alterations, corrections, changes or erasures that are not initialed shall be deemed void and without effect.

- 3) Unless otherwise noted elsewhere in the Bid Documents, facsimile copies of bids are not acceptable.

INSTRUCTIONS TO BIDDERS (Continued)

IB02 Identity or Legal Capacity of the Bidder

- 1) In order to confirm the authority of the person or persons signing the bid or to establish the legal capacity under which the Bidder proposes to enter into Contract, any Bidder who carries on business in other than its own personal name shall, if requested by Canada, provide satisfactory proof of:
 - (a) such signing authority; and
 - (b) the legal capacity under which it carries on business;prior to contract award. Proof of signing authority may be in the form of a certified copy of a resolution naming the signatory(ies) that is (are) authorized to sign this bid on behalf of the corporation or partnership. Proof of legal capacity may be in the form of a copy of the articles of incorporation or the registration of the business name of a sole proprietor or partnership.

IB03 Applicable Taxes

- 1) Bidders are not to include any amounts for Applicable Taxes (Goods and Services Tax (GST), Harmonized Sales Tax (HST) or Quebec Sales Tax (QST), whichever is applicable. Any amount levied in respect of Applicable Taxes shall be billed as a separate item in a progress claim submitted by the Contractor, and shall be paid to the Contractor in addition to the amount approved by Canada for work performed under the Contract. The Contractor shall be required to remit the appropriate amount to the appropriate tax authority in accordance with the applicable legislation.

IB04 Tax to Be Included

- 1) The Contractor is not entitled to use Canada's exemptions from any tax, such as provincial sales taxes, unless otherwise specified by law. The Contractor must pay applicable provincial sales tax, ancillary taxes, and any commodity tax, on taxable goods or services used or consumed in the performance of the Contract (in accordance with applicable legislation), including for material incorporated into real property.

IB05 Capital Development and Redevelopment Charges

- 1) For the purposes of GC1.5 in the General Conditions of the Contract, only fees or charges directly related to the processing and issuing of building permits shall be included. The Bidder shall not include any monies in the bid amount for special municipal development, redevelopment or other fees or charges which a municipal authority may seek as a prerequisite to the issuance of building permits.

IB06 Registry and Pre-qualification of Floating Plant

- 1) Dredges or other floating plant to be used in the performance of the Work must be of Canadian registry. For dredges or other floating plant that are not of Canadian make or manufacture, the Bidder must obtain a certificate of qualification from Industry Canada and this certificate must accompany the bid. Plant so qualified by Industry Canada may be accepted on this project.

IB07 Listing of Subcontractors and Suppliers

- 1) Notwithstanding any list of Subcontractors that the Bidder may be required to submit as part of the bid, the Bidder submitting the lowest acceptable bid shall, within 48 hours of receipt of a notice to do so, submit all information requested in the said notice including the names of Subcontractors and Suppliers for the part or parts of the Work listed. Failure to do so may result in the disqualification of its bid.

INSTRUCTIONS TO BIDDERS (Continued)

IB08 Bid Security Requirements

- 1) **NO** bid security is required for this solicitation notice.

IB09 Submission of Bid

- 1) The BID AND ACCEPTANCE FORM, duly completed, shall be enclosed and sealed in an envelope provided by the Bidder, and shall be addressed and submitted to the office designated on the Front Page of the BID AND ACCEPTANCE FORM for the receipt of bids. The bid must be received on or before the date and time set for solicitation closing.
- 2) Unless otherwise specified in the SPECIAL INSTRUCTIONS TO BIDDERS
 - (a) the bid shall be in Canadian currency;
 - (b) exchange rate fluctuation protection is not offered; and
 - (c) any request for exchange rate fluctuation protection shall not be considered.
- 3) Prior to submitting the bid, the Bidder shall ensure that the following information is clearly printed or typed on the face of the bid envelope:
 - (a) Solicitation/File Number;
 - (b) Name of Bidder;
 - (c) Return address; and
 - (d) Closing Date and Time.
- 4) Subject to paragraph 6) of IB11, failure to comply with paragraphs 1), 2) and 3) of IB09 shall render the bid liable to disqualification. Timely and correct delivery of bids is the sole responsibility of the Bidder.

IB10 Revision of Bid

- 1) A bid submitted in accordance with these instructions may be revised by letter or facsimile provided the revision is received at the office designated for the receipt of bids, on or before the date and time set for the closing of the bid. The letter or facsimile shall:
 - (a) be on the Bidder's letterhead or bear a signature that identifies the Bidder;
 - (b) for the lump sum portion of a bid, clearly identify the amount of the current revision. The total aggregate sum of all revisions submitted, including the current revision, shall be shown separately; and
 - (c) for the Price Per Unit portion of a bid, clearly identify the change(s) in the Price(s) per Unit and the specific Item(s) to which each change applies. If a revision is to be applied to a specific Item that was previously amended then, in addition to the amount of the current revision, the total aggregate sum of all revisions submitted, including the current revision, for that Item shall be shown separately.
- 2) A letter or facsimile submitted to confirm an earlier revision shall be clearly identified as "CONFIRMATION ONLY" for each contemplated change.
- 3) Failure to comply with any of the above provisions shall result in the rejection of the non-compliant revision(s) only. The bid shall be evaluated based on the original bid submitted and all other compliant revision(s).

IB11 Acceptance of Bid

- 1) Canada may accept any bid, whether it is the lowest or not, or may reject any or all bids.
- 2) Without limiting the generality of paragraph 1) of IB11, Canada may reject a bid if any of the following circumstances is present:

INSTRUCTIONS TO BIDDERS (Continued)

- (a) the Bidder, or any employee or subcontractor included as part of the bid, has been convicted under section 121 ("Frauds on the government" & "Contractor subscribing to election fund"), 124 ("Selling or purchasing office"), 380 ("Fraud committed against Her Majesty") or 418 ("Selling defective stores to Her Majesty") of the Criminal Code of Canada; or under paragraph 80(1)(d) ("False entry, certificate of return"), subsection 80(2) ("Fraud against Her Majesty") or Section 154.01 ("Fraud against Her Majesty") of the *Financial Administration Act*;
 - (b) the Bidder's bidding privileges are suspended or are in the process of being suspended;
 - (c) the bidding privileges of any employee or subcontractor included as part of the bid are suspended or are in the process of being suspended, which suspension or pending suspension would render that employee or subcontractor ineligible to bid on the Work, or the portion of the Work the employee or subcontractor is to perform;
 - (d) with respect to current or prior transactions with Canada
 - (i) the Bidder is bankrupt or if, for whatever reason, its activities are rendered inoperable for an extended period;
 - (ii) evidence, satisfactory to Canada, of fraud, bribery, fraudulent misrepresentation or failure to comply with any law protecting individuals against any manner of discrimination, has been received with respect to the Bidder, any of its employees or any subcontractor included as part of its bid;
 - (iii) Canada has exercised, or intends to exercise, the contractual remedy of taking the work out of the contractor's hands with respect to a contract with the Bidder, any of its employees or any subcontractor included as part of its bid; or
 - (iv) Canada determines that the Bidder's performance on other contracts is sufficiently poor to jeopardize the successful completion of the requirement being bid on.
- 3) In assessing the Bidder's performance on other contracts pursuant to subparagraph 2)(d)(iv) of IB11, Canada may consider, but not be limited to, such matters as:
- (a) the quality of workmanship in performing the Work;
 - (b) the timeliness of completion of the Work;
 - (c) the overall management of the Work and its effect on the level of effort demanded of the department and its representative; and
 - (d) the completeness and effectiveness of the Contractor's safety program during the performance of the Work.
- 4) Without limiting the generality of paragraphs 1), 2) and 3) of IB11, Canada may reject any bid based on an unfavourable assessment of the:
- (a) adequacy of the bid price to permit the work to be carried out and, in the case of a bid providing prices per unit or a combination of lump sum and prices per unit, whether each such price reasonably reflects the cost of performing the part of the work to which that price applies;
 - (b) Bidder's ability to provide the necessary management structure, skilled personnel, experience and equipment to perform competently the work under the Contract; and
 - (c) Bidder's performance on other contracts.
- 5) If Canada intends to reject a bid pursuant to a provision of paragraphs 1), 2), 3) or 4) of IB11, other than subparagraph 2)(b) of IB11, Canada shall so inform the Bidder and provide the Bidder ten (10) days within which to make representations, prior to making a final decision on the bid rejection.
- 6) Canada may waive informalities and minor irregularities in bids received if Canada determines that the variation of the bid from the exact requirements set out in the Bid Documents can be corrected or waived without being prejudicial to other Bidders.

INSTRUCTIONS TO BIDDERS (Continued)

IB12 Bid Costs

- 1) No payment will be made for costs incurred in the preparation and submission of a bid in response to the bid solicitation. Costs associated with preparing and submitting a bid, as well as any costs incurred by the Bidder associated with the evaluation of the bid, are the sole responsibility of the Bidder.

IB13 Compliance with Applicable Laws

- 1) By submission of a bid, the Bidder certifies that the Bidder has the legal capacity to enter into a contract and is in possession of all valid licences, permits, registrations, certificates, declarations, filings, or other authorizations necessary to comply with all federal, provincial and municipal laws and regulations applicable to the submission of the bid and entry into any ensuing contract for the performance of the work.
- 2) For the purpose of validating the certification in paragraph 1) of IB13, a Bidder shall, if requested, provide a copy of every valid licence, permit, registration, certificate, declaration, filing or other authorization listed in the request, and shall provide such documentation within the time limit(s) set out in the said request.
- 3) Failure to comply with the requirements of paragraph 2) of IB13 shall result in disqualification of the bid.

IB14 Approval of Alternative Materials

- 1) When materials are specified by trade names or trademarks, or by manufacturers' or suppliers' names, the bid shall be based on use of the named materials. During the bid period, alternative materials may be considered provided full technical data is received in writing by the Contracting Officer at least 10 calendar days prior to the bid closing date.

IB15 Income Tax Requirement

- 1) Payments made under applicable contracts must be reported by Canada for taxation purposes. To comply with this requirement, the successful bidder shall provide to Canada immediately upon award: its legal name; address; and Revenue Canada identifier (SIN, BN, GST/HST, T2N number) as is applicable.

IB16 Contingency Fees

- 1) The Bidder declares that the Bidder has not, directly or indirectly, paid or agreed to pay, and will not, directly or indirectly, pay a contingency fee to any individual for the solicitation, negotiation or obtaining of the contract if the payment of the fee would require the individual to file a return under section 5 of the *Lobbying Act*.

IB17 Status of the Bidder

- 1) The Bidder declares that the Bidder has not been convicted of an offence, other than an offence for which a pardon has been granted, under section 121, 124 or 418 of the *Criminal Code*.

IB18 Integrity Provisions - Bids Over \$10,000.00

INSTRUCTIONS TO BIDDERS (Continued)

- 1) Ineligibility and Suspension Policy (the "Policy"), and all related Directives, are incorporated by reference into, and form a binding part of the procurement process. The Supplier must comply with the Policy and Directives, which can be found at [Ineligibility and Suspension Policy](#).
- 2) Under the Policy, charges and convictions of certain offences against a Supplier, its affiliates or first tier subcontractors, and other circumstances, will or may result in a determination by Public Works and Government Services Canada (PWGSC) that the Supplier is ineligible to enter, or is suspended from entering into a contract with Canada. The list of ineligible and suspended Suppliers is contained in PWGSC's Integrity Database. The Policy describes how enquiries can be made regarding the ineligibility or suspension of Suppliers.
- 3) In addition to all other information required in the procurement process, the Supplier must provide the following:
 - a. by the time stated in the Policy, all information required by the Policy described under the heading "Information to be Provided when Bidding, Contracting or Entering into a Real Property Agreement"; and
 - b. with its bid / quote / proposal, a complete list of all foreign criminal charges and convictions pertaining to itself, its affiliates and its proposed first tier subcontractors that, to the best of its knowledge and belief, may be similar to one of the listed offences in the Policy. The list of foreign criminal charges and convictions must be submitted using an Integrity Declaration Form, which can be found at [Declaration form for procurement](#).
- 4) Subject to subsection 5, by submitting a bid / quote / proposal in response a request by AAFC, the Supplier certifies that:
 - a. it has read and understands the [Ineligibility and Suspension Policy](#);
 - b. it understands that certain domestic and foreign criminal charges and convictions, and other circumstances, as described in the Policy, will or may result in a determination of ineligibility or suspension under the Policy;
 - c. it is aware that Canada may request additional information, certifications, and validations from the Supplier or a third party for purposes of making a determination of ineligibility or suspension;
 - d. it has provided with its bid / quote / proposal a complete list of all foreign criminal charges and convictions pertaining to itself, its affiliates and its proposed first tier subcontractors that, to the best of its knowledge and belief, may be similar to one of the listed offences in the Policy;
 - e. none of the domestic criminal offences, and other circumstances, described in the Policy that will or may result in a determination of ineligibility or suspension, apply to it, its affiliates and its proposed first tier subcontractors; and
 - f. it is not aware of a determination of ineligibility or suspension issued by PWGSC that applies to it.
- 5) Where a Supplier is unable to provide any of the certifications required by subsection 4, it must submit with its bid/ quote / proposal a completed Integrity Declaration Form, which can be found at [Declaration form for procurement](#).
- 6) Canada will declare non-responsive any bid / quote / proposal in respect of which the information requested is incomplete or inaccurate, or in respect of which the information contained in a certification or declaration is found by Canada to be false or misleading in any respect. If Canada

INSTRUCTIONS TO BIDDERS (Continued)

establishes after award of the Contract that the Supplier provided a false or misleading certification or declaration, Canada may terminate the Contract for default. Pursuant to the Policy, Canada may also determine the Supplier to be ineligible for award of a contract for providing a false or misleading certification or declaration.

Ineligibility and Suspension Policy - <http://www.tpsgc-pwgsc.gc.ca/ci-if/politique-policy-eng.html>

Declaration form for procurement - <http://www.tpsgc-pwgsc.gc.ca/ci-if/declaration-eng.html>

IB19 Code of Conduct for Procurement - Bid

- 1) The Code of Conduct for Procurement provides that Bidders must respond to bid solicitations in an honest, fair and comprehensive manner, accurately reflect their capacity to satisfy the requirements set out in the bid solicitation and resulting contract, submit bids and enter into contracts only if they will fulfill all obligations of the Contract. By submitting a bid, the Bidder is certifying that it is complying with the Code of Conduct for Procurement. Failure to comply with the Code of Conduct for Procurement may render the bid non-responsive.



Appendix "B"

SPECIAL INSTRUCTIONS TO BIDDERS



SPECIAL INSTRUCTIONS TO BIDDERS

- SI01 Bid Documents
- SI02 Enquiries during the Solicitation Period
- SI03 Non-Mandatory Site Visit
- SI04 Revision of Bid
- SI05 Bid Results
- SI06 Bid Validity Period
- SI07 Construction Documents
- SI08 Personnel Security Requirements
- SI09 Integrity Provisions - Declaration of Convicted Offences

SI01 BID DOCUMENTS

1) The following are the bid documents:

- (a) SPECIAL INSTRUCTIONS TO BIDDERS;
- (b) INSTRUCTIONS TO BIDDERS - Form A5319-E; and,
- (c) BID AND ACCEPTANCE FORM - Form A5312-E and any attachments thereto.

Canada reserves the right to revise or amend the Bid Documents prior to the date set for opening bids. Such revisions or amendments, if any, will be announced by an addendum or addenda to the documents.

Submission of a bid constitutes acknowledgement that the Bidder has read and agrees to be bound by these documents.

SI02 ENQUIRIES DURING THE SOLICITATION PERIOD

1) Enquiries regarding this bid must be submitted in writing to the Contracting Officer. The Contracting Officer for the purpose of this bid is:

Al i ne Mul i nda
Agriculture and Agri -Food Canada
2001 Robert Bourassa blvd., 671 -TEN
Montreal, Quebec, H3A 3N2
Tel ephone: 514 315-6140
Facsi mi le: 514 283-1918
Emai l : al i ne. mul i nda@canada. ca

- 2) Except for the approval of alternative materials as described in IB14 of the INSTRUCTIONS TO BIDDERS, enquiries should be received no later than five (5) calendar days prior to the date set for solicitation closing to allow sufficient time to provide a response. Enquiries received after that time may not result in an answer being provided.
- 3) To ensure consistency and quality of the information provided to Bidders, the Contracting Officer shall examine the content of the enquiry and shall decide whether or not to issue an amendment.
- 4) All enquiries and other communications related to this bid sent throughout the solicitation period are to be directed ONLY to the Contracting Officer. Non-compliance with this requirement during the solicitation period can, for that reason alone, result in disqualification of a bid.

SPECIAL INSTRUCTIONS TO BIDDERS (Continued)

SI03 NON-MANDATORY SITE VISIT

- 1) Before submitting their bid, the Contractor shall examine the jobsite, construction and storage areas, compare drawings and specifications with existing conditions, and fully satisfy themselves as to all data and matters required for the completion of the contract.
- 2) There will be a site visit on Tuesday, June, 12, 2018 at 10: 00 AM PM Local Standard Time.

Interested bidders are to meet at:

The Sherbrooke Research and Development Centre located at 2000 College Street, Sherbrooke, QC, J1M 0C8. Tenderers are requested to be present at the reception desk at least 10 minutes prior to the meeting.

SI04 REVISION OF BID

- 1) A bid may be revised by letter or facsimile in accordance with IB10 of the INSTRUCTIONS TO BIDDERS. The facsimile number for receipt of revisions is: 514 283-1918 .

SI05 BID RESULTS

- 1) Following bid closing, bid results may be obtained from the bid receiving office by email at alinea.mulinda@canada.ca .

SI06 BID VALIDITY PERIOD

- 1) Canada reserves the right to seek an extension to the bid validity period prescribed in Clause 4 of the BID AND ACCEPTANCE FORM. Upon notification in writing from Canada, Bidders shall have the option to either accept or reject the proposed extension.

SI07 CONSTRUCTION DOCUMENTS

- 1) The successful contractor will be provided with one paper copy of the sealed and signed drawings, the specifications and the amendments upon acceptance of the offer. Additional copies, up to a maximum of Zero (0) , will be provided free of charge upon request by the Contractor. Obtaining more copies shall be the responsibility of the Contractor including costs.

SI08 PERSONNEL SECURITY REQUIREMENTS

- 1) The successful Bidder's personnel, as well as any subcontractor and its personnel, who are required to perform any part of the work pursuant to the subsequent contract, must meet the following contract security requirements:
 - Unscreened personnel may be used for the work. Unscreened personnel will require an escort provided by AAFC.

SPECIAL INSTRUCTIONS TO BIDDERS (Continued)

SI09 INTEGRITY PROVISIONS – DECLARATION OF CONVICTED OFFENCES

As applicable, pursuant to IB18 of the Declaration of Convicted Offences, paragraph 10 (copied below) of the General Instruction AAFC / AAC5319, the Bidder must provide with its bid, a completed *Declaration Form*, to be given further consideration in the procurement process.

Declaration of Convicted Offences

Where a Bidder or its Affiliate is unable to certify that it has not been convicted of any of the offences referenced under the Canadian Offences Resulting in Legal Incapacity, the Canadian Offences and the Foreign Offences subsections, the Bidder must provide with its bid the completed [Declaration Form](#), to be given further consideration in the procurement process.



Appendix "C"

BID AND ACCEPTANCE FORM

BID AND ACCEPTANCE FORM
CONSTRUCTION CONTRACT - MINOR WORKS

Solicitation / File Number: 01B46-18-032
Project: REPAIR OF THE SLATS OF THE SLATTED FLOORS IN ROOMS C-101, C-102 AND C-103 OF THE SWINE COMPLEX
Contract:

MAIL OR DELIVER BID TO:
Agriculture and Agri-Food Canada
Assets Team - Eastern Service Centre
Tender Receiving Unit
2001 Robert-Bourassa Blvd., suite 671-TEN
Montreal, Quebec, H3A 3N2

BID CLOSING TIME:
Thursday, June 21, 2018
Day of week Month Day Year
at 02:00 AM PM local time.

DESCRIPTION OF WORKS:
REPAIR OF THE SLATS OF THE SLATTED FLOORS IN ROOMS C-101, C-102 AND C-103 OF THE SWINE COMPLEX

INSTRUCTIONS TO BIDDERS:
Bidders shall be governed by the following instructions:
- SPECIAL INSTRUCTIONS TO BIDDERS - Form AAFC / AAC5318-E
- INSTRUCTIONS TO BIDDERS - Form AAFC / AAC5319-E

The following additional documents form an attachment to this BID AND ACCEPTANCE FORM:
 List of Suppliers

OFFER AND AGREEMENT

1. The undersigned bidder (hereinafter called the "Contractor") hereby offers to Her Majesty the Queen in right of Canada, as represented by the Minister of Agriculture and Agri-Food (hereinafter called "Canada"), to furnish all necessary labour, plant and material and to execute and complete in a satisfactory and workmanlike manner all the work required under this contract for the consideration of the unit or lump sum price or prices set forth in the Price Table below. The Contractor agrees that these prices include all applicable provincial sales taxes, ancillary taxes and any commodity tax. Note: Do not include Applicable Taxes (GST/HST/QST) as defined in the General Conditions in price(s).

PRICE TABLE					
Item	Class of Labour, Plant, or Material	Unit of Measurement	Estimated Total Quantity	Price Per Unit	Estimated Total Price
1	REPAIR OF THE SLATS OF THE SLATTED FLOORS IN ROOMS C-101, C-102 AND C-103 OF THE SWINE COMPLEX	Lump sum	N/A		
2	Unit price for Slats	Unit price	N/A		N/A
NOTE: Both price per unit and estimated total price must be filled in for each item in the Price Table. All estimated total prices will be subject to verification by Canada. In case of variation between the price per unit and the estimated total price, the price per unit will be considered to be the price bid.				Total Bid	

2. The Contractor shall perform and complete the Work on or before 2018-09-30.
3. The Contractor hereby acknowledges receipt of the following addenda to the bid documents (give number and date of each):
Addenda numbers: _____ Dates: _____
4. The Contractor agrees that this offer: supersedes and cancels all communications, negotiations, and agreements relating to the work other than contained in this completed bid or any amendment incorporated by mutual agreement between the Contractor and Canada before acceptance of this Offer and Agreement; is irrevocable for 30 days after the Bid Closing Time shown hereon.
5. The Contractor agrees, that the complete bid together with and subject to all the provisions contained herein shall, when accepted and executed on behalf of Canada, constitute a binding contract between the Contractor and Canada.
6. The following additional documents form an attachment to a binding contract:
6.1 GENERAL CONDITIONS FOR MINOR WORKS - Form AAFC / AAC5316-E

BID AND ACCEPTANCE FORM (Continued)

6.2 Specifications

6.3 Insurance Terms

CONTRACTOR'S FULL BUSINESS NAME (Please print or type)

--

CONTRACTOR'S BUSINESS ADDRESS (for all purposes of or incidental to the contract)

Unit/Suite/Apt.	Street number	Number suffix	Street name	Street type	Street direction	
PO Box or Route Number		Municipality (City, Town, etc.)			Province	Postal code
Telephone number	Ext.	Facsimile number	E-mail (optional)		GST/HST number	

Attested to and Delivered on Behalf of the Contractor this _____ day of _____, _____.
Month Year

CONTRACTOR'S or, where applicable, SIGNING OFFICER'S SIGNATURE(S)	TITLE(S)	In the presence of: WITNESS SIGNATURE(S)

NOTE: Corporate Firms shall affix their Corporate Seal if applicable.

(FOR DEPARTMENTAL USE ONLY)

Accepted and Executed on Behalf of Canada this _____ day of _____, _____.
Month Year

SIGNATURE	TITLE	In the presence of: WITNESS SIGNATURE

Bid opened in _____ on _____, _____ at _____ AM PM local time.
Location Day of week Month Day Year

in the presence of _____

BID AND ACCEPTANCE FORM (Continued)

INTEGRITY PROVISIONS - LIST OF NAMES
(complete if your bid exceeds \$10,000.00)

If the required list of names has not been received by the time the evaluation of bids is completed, Canada will inform the Bidder of a time frame within which to provide the information. Failure to provide the names within the time frame specified will render the bid non-responsive. Providing the required names is a mandatory requirement for contract award.

Bidders who are incorporated, including those bidding as a joint venture, must provide a complete list of names of all individuals who are currently directors of the Bidder.

Bidders bidding as sole proprietorship, as well as those bidding as a joint venture, must provide the name of the owner(s).

Bidders bidding as societies, firms or partnerships do not need to provide lists of names.



Appendix "D"

GENERAL CONDITIONS FOR MINOR WORKS



TABLE OF CONTENTS GENERAL CONDITIONS FOR MINOR WORKS

GC 1	GENERAL PROVISIONS
GC 1.1	Definition
GC 1.2	Contract Documents
GC 1.3	Assignment
GC 1.4	Subcontracting
GC 1.5	Laws, Permits and Taxes
GC 1.6	Former Public Office Holders
GC 1.7	Status of the Contractor
GC 1.8	Contingency Fees
GC 1.9	Disclosure of Basic Information
GC 1.10	Integrity Provisions - Contracts over \$10,000.00
GC 1.11	Code of Conduct for Procurement - Contracts over \$10,000.00
GC 2	ADMINISTRATION OF THE CONTRACT
GC 2.1	Departmental Representative's Rights and Obligations
GC 2.2	Contractor's Superintendent and Workers
GC 2.3	Records to be Kept by the Contractor
GC 2.4	Notices
GC 3	EXECUTION OF THE WORK
GC 3.1	Material, Plant and Real Property Become the Property of Canada
GC 3.2	Cooperation With Other Contractors
GC 3.3	Use of the Work and Cleanup of Site
GC 3.4	Warranty and Rectification of Defects
GC 4	PROTECTION, HEALTH AND SAFETY
GC 4.1	Material, Plant and Real Property Supplied by Canada
GC 4.2	Construction Safety
GC 5	TERMS OF PAYMENT
GC 5.1	Definitions
GC 5.2	Payment - General Provisions
GC 5.3	Progress Payments
GC 5.4	Interest on Overdue Accounts
GC 5.5	Payment in the Event of Termination
GC 5.6	Final Completion
GC 5.7	Determination of Price
GC 5.8	Claims Against and Obligations of the Contractor or Subcontractor
GC 6	CHANGES IN THE WORK
GC 6.1	Changes in the Work
GC 6.2	Changes in Subsurface Conditions and Delays by Canada
GC 6.3	Extension of Time
GC 7	DEFAULT, SUSPENSION OR TERMINATION OF CONTRACT
GC 7.1	Taking the Work Out of the Contractor's Hands
GC 7.2	Effect of Taking the Work Out of the Contractor's Hands
GC 7.3	Suspension of the Contract
GC 7.4	Termination of the Contract
GC 8	DISPUTE RESOLUTION
GC 9	INDEMNIFICATION AND INSURANCE
GC 9.1	Indemnification
GC 9.2	Insurance Contracts
GC 9.3	Insurance Proceeds



GENERAL CONDITIONS FOR MINOR WORKS

GC 1 GENERAL PROVISIONS

GC 1.1 Definition

- "Applicable Taxes" means the Goods and Services Tax (GST), the Harmonized Sales Tax (HST), and any provincial tax, by law, payable by Canada such as, the Quebec Sales Tax (QST) as of April 1, 2013.
- "Canada", "Her Majesty" means Her Majesty, the Queen in right of Canada;
- "Contract" means the contract documents referred to as such therein and every other document specified or referred to in any of them as forming part of the Contract, all as amended by agreement of the parties;
- "Contractor" means a person, with whom Canada enters into a Contract to do the Work;
 - "Departmental Representative" means the person designated in the Contract, or by written notice to the Contractor, to act as the Departmental Representative for the purposes of the Contract, and includes a person, designated and authorized in writing by the Departmental Representative to the Contractor;
- "Material" includes all commodities, articles, machinery, equipment, fixtures and things required to be furnished in accordance with the Contract for incorporation into the Work;
- "Person" includes, unless there is an express stipulation in the Contract to the contrary, any partnership, proprietorship, firm, joint venture, consortium or corporation;
- "Plant" includes all tools, implements, machinery, vehicles, structures, equipment, articles and things that are necessary for the performance of the Contract, other than Material and those tools customarily provided by a trades person in practicing a trade;
- "Work" means everything that is necessary to be done, furnished or delivered by the Contractor to perform the Contract in accordance with the Contract Documents;

GC 1.2 Contract Documents

1. In interpreting the Contract, in the event of discrepancies or conflicts between anything in the Drawings and Specifications or Scope of Work and the General Conditions, the General Conditions govern.
2. In interpreting the Drawings and Specifications, in the event of discrepancies or conflicts between:
 - (a) the Drawings and Specifications, the Specifications govern;
 - (b) the Drawings, the Drawings with the largest scale govern; and
 - (c) figured dimensions and scaled dimensions, the figured dimensions govern.

GC 1.3 Assignment

1. This Contract shall not be assigned without the written consent of Canada.

GC 1.4 Subcontracting

1. The Contractor shall:
 - (a) not subcontract the whole or any part of the Work without the written consent of the Departmental Representative except for subcontracts specified in the Contract; and
 - (b) ensure that all subcontracts entered into at any tier shall incorporate all the terms and conditions of the Contract that can reasonably be applied thereto.

GENERAL CONDITIONS FOR MINOR WORKS (Continued)

GC 1.5 Laws, Permits and Taxes

1. The Contractor shall comply with all legislative and regulatory provisions whether federal, provincial, territorial or municipal applicable to the performance of the Work and shall require compliance therewith by all of its subcontractors and suppliers at any tier as if the Work were being performed for an owner other than Canada.
2. Unless otherwise provided for in the Contract, the Contractor shall obtain all permits and hold all certificates and licenses required for the performance of the Work.
3. Applicable Taxes will be paid by Canada at time when a progress payment is being made. It is the sole responsibility of the Contractor to charge Applicable Taxes at the correct rate in accordance with applicable legislation. The Contractor agrees to remit to appropriate tax authorities any amounts of Applicable Taxes paid or due.
4. The Contractor is not entitled to use Canada's exemptions from any tax, such as provincial sales taxes, unless otherwise specified by law. The Contractor must pay applicable provincial sales tax, ancillary taxes, and any commodity tax, on taxable goods or services used or consumed in the performance of the Contract (in accordance with applicable legislation), including for material incorporated into real property.

GC 1.6 Former Public Office Holders

1. No former public office holder who is not in compliance with the post-employment provisions of the Conflict of Interest and Post-Employment Code for Public Office Holders shall derive a direct benefit from the Contract.

GC 1.7 Status of the Contractor

1. The Contractor is engaged as an independent Contractor for the sole purpose of performing the Work. Neither the Contractor nor any of its personnel is engaged as an employee, servant or agent of Canada. The Contractor is responsible for all deductions and remittances required by law in relation to its employees including those required for Canada or Quebec Pension Plans, employment insurance, workers' compensation, and income tax.
2. The Contractor declares that the Contractor has not been convicted of an offence, other than an offence for which a pardon has been granted, under section 121, 124 or 418 of the Criminal Code.

GC 1.8 Contingency Fees

1. The Contractor declares that the Contractor has not, directly or indirectly, paid or agreed to pay, and will not, directly or indirectly, pay a contingency fee to any individual for the solicitation, negotiation or obtaining of the contract if the payment of the fee would require the individual to file a return under section 5 of the *Lobbying Act*.

GC 1.9 Disclosure of Basic Information

1. The Contractor consents, in the case of a contract that has a value in excess of \$10,000, to the public disclosure of basic information, other than information described in any of paragraphs 20(1)(a) to (d) of the Access to Information Act, relating to the contract.

GENERAL CONDITIONS FOR MINOR WORKS (Continued)

GC 1.10 Integrity Provisions - Contracts over \$10,000.00

- 1) The Ineligibility and Suspension Policy (the "Policy") and all related Directives are incorporated into, and form a binding part of the Contract. The Contractor must comply with the provisions of the Policy and Directives, which can be found on Public Works and Government Services Canada's website at Ineligibility and Suspension Policy. (<http://www.tpsgc-pwgsc.gc.ca/ci-if/politique-policy-eng.html>).

GC 1.11 Code of Conduct for Procurement - Contracts Over \$10,000.00

- 1) The Contractor agrees to comply with the Code of Conduct (<http://www.tpsgc-pwgsc.gc.ca/app-acq/cndt-cndct/contexte-context-eng.html>) for Procurement and to be bound by its terms for the period of the Contract.

GC 2 ADMINISTRATION OF THE CONTRACT

GC 2.1 Departmental Representative's Rights and Obligations

1. The Departmental Representative shall:
 - (a) have access to the Work at all times;
 - (b) decide questions regarding what has been done or what the Contractor is required to do;
 - (c) decide questions regarding the acceptability of the quality or quantity of any Labour, Plant or Material used or consumed in the execution of the Work; and
 - (d) decide questions regarding the timing and scheduling of the Work.

GC 2.2 Contractor's Superintendent and Workers

1. The Contractor shall keep a competent superintendent and capable and skilled workers on the site of the Work at all times during the progress of the Work. If, in the opinion of the Departmental Representative, the superintendent or the workers are deemed to be unacceptable because of incompetence, improper conduct or security risk, they shall be removed from the site of the Work and replaced forthwith.

GC 2.3 Records to be Kept by the Contractor

1. The Contractor shall maintain and keep intact complete records relating to the Work together with all tender calls, quotations, contracts, correspondence, invoices and any payment of fees or other compensation for the solicitation, negotiating or obtaining of the contract until the expiration of two (2) years after the date that a Certificate of Completion is issued or the final invoice is paid if no Certificate of Completion is issued. The Contractor shall, upon request from the Departmental Representative, make said records available for copy, audit or inspection to any person(s) acting on behalf of Canada.
2. The Contractor shall cause all Subcontractors, and all other Persons or entities directly or indirectly involved with the Work, to comply with the requirements of GC 2.3.1.

GC 2.4 Notices

1. Any notice shall be in writing and may be delivered by hand, by courier, by registered or regular mail, or by facsimile or other electronic means that provides a paper record of the text of the notice. The notice shall be addressed to the party for whom it is intended at the address in the Contract or at the last address from which the sender has received notice in accordance with this

GENERAL CONDITIONS FOR MINOR WORKS (Continued)

section. Any notice shall be deemed to be effective on the day it is received at that address or four (4) days after being sent, whichever is the earlier.

GC 3 EXECUTION OF THE WORK

GC 3.1 Material, Plant, and Real Property Become the Property of Canada

1. All Material and Plant used or consumed for the purposes of the Work shall be the property of Canada. The Material and Plant shall be used only for the purposes of the Work, and shall not be removed from the site of the Work until so approved by the Departmental Representative.
2. The Contractor shall be liable for all loss or damage to Material or Plant that is the property of Canada by virtue of this section.

GC 3.2 Cooperation with Other Contractors

1. The Contractor shall cooperate fully with other contractors or workers sent onto the site of the Work by the Departmental Representative.
2. If, at the time the Contract was executed: the Contractor could not have reasonably foreseen the sending of other contractors or workers onto the site of the Work; and, the Contractor incurs extra costs in complying with GC 3.2.1; and, the Contractor gives written notice of claim for the extra costs within ten (10) days from the date upon which the other contractors or workers were sent onto the site of the Work; then, Canada shall pay an additional amount to the Contractor, calculated pursuant to GC 5.7.

GC 3.3 Use of the Work and Cleanup of Site

1. The Contractor shall maintain the site of the Work in a tidy condition and free from the accumulation of waste material throughout the duration of the Contract.
2. Before the Departmental Representative issues the Certificate of Completion or approves payment of the final invoice, the Contractor shall remove all materials, tools, construction machinery, equipment, waste products and debris from the site of the Work.
3. Where the Work affects occupied portions of a building, the Contractor shall ensure continuity of all building services and shall ensure safe access for all persons requiring access to said building.

GC 3.4 Warranty and Rectification of Defects

1. Without restricting any warranty or guarantee implied or imposed by law or any extended warranty specified in the Contract, the Contractor shall, upon notice from the Departmental Representative and at its own expense, rectify all defects which appear in the Work within twelve (12) months from the date of issuance of the Certificate of Completion pursuant to GC 5.6.1, or from the date of the negotiable instrument issued as final payment if a Certificate of Completion is not issued, whichever is applicable.
2. The notice referred to in GC 3.4.1 shall be in writing and shall include the number of days within which the defect or fault is to be rectified.
3. The Contractor shall transfer and assign, to Canada, any subcontractor, manufacturer or supplier extended warranties or guarantees implied or imposed by law or contained in the contract documents covering periods beyond the twelve (12) months stipulated above. Extended

GENERAL CONDITIONS FOR MINOR WORKS (Continued)

warranties or guarantees referred to herein shall not extend the twelve (12) month period whereby the Contractor must rectify and make good any defect or fault that appears in the work or comes to the attention of Canada.

GC 4 PROTECTION, HEALTH AND SAFETY

GC 4.1 Material, Plant and Real Property Supplied by Canada

1. The Contractor, having care, custody and control of the Work and its site, shall be responsible for any loss or damage, excluding reasonable wear and tear, to any property of Canada arising out of the performance of the Work whether or not such loss arises from causes beyond the Contractor's control.

GC 4.2 Construction Safety

1. The Contractor shall be responsible for the health and safety of all persons granted access to the site of the Work and for initiating, maintaining and supervising all safety inspections, precautions and programs in connection with the performance of the Work in accordance with the health and safety legislation in force in the Province where the Work is being performed.

GC 5 TERMS OF PAYMENT

GC 5.1 Definitions

For the purposes of this section:

- Payment Period means a period of thirty (30) days or such other longer period as may be agreed between the Contractor and the Departmental Representative.
- An amount is Due and Payable when it is due and payable by Canada to the Contractor in accordance with the terms of the Contract.
- An amount is Overdue when it remains unpaid after the day upon which it is due and payable.
- Date of Payment means the date of the negotiable instrument of an amount due and payable by the Receiver General for Canada.
- Fixed Price Arrangement means that part of the Contract that prescribes a lump sum as payment for performance of the Work to which it relates.
- Unit Price Arrangement means that part of the Contract that prescribes the product of a Price Per Unit multiplied by a number of Units of Measurement of a Class as payment for performance of the Work to which it relates.
- Price Table means the table set out in the BID AND ACCEPTANCE FORM.
- Bank Rate means the rate of interest established from time to time by the Bank of Canada as the minimum rate at which the Bank of Canada makes short term advances to members of the Canadian Payments Association.
- Average Bank Rate means the simple arithmetic mean of the Bank Rates in effect at 4:00 pm Eastern Time each day during the calendar month which immediately precedes the calendar month in which payment is made.
- Duration of the Work means the number of calendar days required to complete the Work, commencing on the first day following receipt by the Contractor of the fully executed Contract and ending the day on which the Departmental Representative verifies that the Work has been satisfactorily completed.

GC 5.2 Payment - General Provisions

GENERAL CONDITIONS FOR MINOR WORKS (Continued)

1. It is a condition precedent to Canada's obligation under GC 5.3.5 that the Contractor has made and delivered to the Departmental Representative, a statutory declaration as described in GC 5.2.2.
2. A statutory declaration in a form acceptable to Canada shall contain a declaration that the Contractor has complied with all lawful obligations with respect to workers and that all lawful obligations towards Subcontractors and Suppliers in respect of the Work under the Contract have been fully discharged.
3. A payment by Canada pursuant to this section shall not be construed as evidence that the Work is satisfactory or in accordance with the Contract.
4. Delay in making payment by Canada under the Contract shall not constitute a breach of Contract.
5. Without limiting any right of setoff or deduction given or implied by law or elsewhere in the Contract, Canada may retain from amounts payable to the Contractor under the Contract, any amount payable to Canada by the Contractor under the Contract or any other current contract.
6. No additional payment shall be made for delays where the cause of the delay was under the control of the Contractor.
7. Except as provided for in these General Conditions, the amount payable to the Contractor under the Contract shall not be increased or decreased by reason of any increase or decrease in cost of the Work brought about by any increase in the cost of Labour, Plant or Material.
8. In the event of a change, including a new imposition or repeal of any tax, customs or other duty, charge, or any similar imposition that is imposed under sales or excise tax legislation of the Government of Canada or any Provincial or Territorial legislation, affects the cost of the Work to the Contractor, and occurs after the date of submission by the Contractor of the Contractor's bid, the contract amount shall be adjusted by an amount equal to the increased or decreased cost to the Contractor, which amount shall be determined through a detailed examination of the Contractor's records.
9. It is a term of every contract providing for the payment of any money by Her Majesty that payment under that contract is subject to there being an appropriation for the particular service for the fiscal year in which any commitment under that contract would come in course of payment. Section 40, *Financial Administration Act*, R.S., 1985, c. F-11, s. 40.

GC 5.3 Progress Payments

1. Where the duration of the Work is greater than thirty (30) days, the Contractor shall be entitled to receive monthly progress payments upon submitting a progress claim in a form approved by the Departmental Representative. Where the duration of the Work is less than thirty (30) days, the Contractor shall submit a progress claim after the Work is complete.
2. On the expiration of a Payment Period, the Contractor shall deliver to the Departmental Representative:
 - (a) a written progress claim that fully describes any part of the Work that has been satisfactorily completed and any Material that was delivered to the site of the Work but not incorporated into the Work during the Payment Period for which the progress claim relates;
 - (b) a completed and signed statutory declaration as described in GC 5.2.2; and

GENERAL CONDITIONS FOR MINOR WORKS (Continued)

- (c) in the case of the initial progress claim and the request for final payment, satisfactory evidence of compliance with workers compensation legislation that is applicable to the place of the Work.
- 3. Not later than ten (10) days after receipt of a progress claim properly submitted in accordance with GC 5.3.2, the Departmental Representative shall issue a progress report, a copy of which shall be given to the Contractor.
- 4. A progress report shall indicate the value of the part of the Work and Material described in the progress claim that, in the opinion of Canada:
 - (a) is in accordance with the Contract; and
 - (b) was not included in any other progress report related to the Contract.
- 5. Not later than thirty (30) days after the receipt by the Departmental Representative of a properly submitted progress claim and supporting documentation, Canada shall make a progress payment to the Contractor in an amount that is equal to one of the following:
 - (a) 90 percent of the value that is indicated in the progress report; or
 - (b) If the Departmental Representative is satisfied that the Work is substantially complete and is acceptable for use by Canada, 100 percent of the value of the Work and Material that is in accordance with the Contract, less amounts previously paid for under the Contract, less the amount equal to the estimated cost of completing the Work and the estimated cost of rectifying defects and faults in the Work as determined by the Departmental Representative; or
 - (c) If the Departmental Representative is satisfied that the Work is complete, 100 percent of the value of the Work that is in accordance with the Contract less amounts previously paid for under the Contract;plus Applicable Taxes and less the aggregate of any amounts payable to or costs and damages claimed by Canada or by a Claimant against the Contractor.
- 6. The Departmental Representative reserves the right to increase or decrease the quantities submitted by the Contractor if there is a disagreement between the Contractor's invoiced quantities and the quantities shown in the records maintained at the site of the Work.
- 7. Subject to GC 5.3.8, GC 5.3.9 and GC 5.3.10, the Departmental Representative and the Contractor may, by an agreement in writing, amend a Price Per Unit as set out in the Price Table for any Class of Labour, Plant or Material provided the Certificate of Measurement shows that the Authorized Quantity of the Class of Labour, Plant or Material actually performed, used or supplied by the Contractor in performing the Work is:
 - (a) less than 85 percent of the Estimated Total Quantity; or
 - (b) in excess of 115 percent of the Estimated Total Quantity.
- 8. In no event shall the total amount of an Item set out in the Price Table that has been amended pursuant to GC 5.3.7 (a) exceed the amount that would have been Payable to the Contractor had the Estimated Total Quantity actually been performed, used, or supplied.
- 9. An amendment that is made necessary by GC 5.3.7 (b) shall apply only to the quantities that are in excess of 115 percent.
- 10. Where the Departmental Representative and the Contractor fail to agree on the amount of any adjustment to a Price Per Unit as contemplated by GC 5.3.7, the amended Price Per Unit shall be determined in accordance with GC 5.7.

GENERAL CONDITIONS FOR MINOR WORKS (Continued)

GC 5.4 Interest on Overdue Accounts

1. Canada shall be liable to pay, to the Contractor, simple interest at the Average Bank Rate plus 3 percent per annum on any amount that is Overdue. The interest shall apply from the date such amount becomes Overdue until the day prior to the Date of Payment inclusively.
2. Interest shall be paid to the Contractor without demand on Overdue payments, except, in respect to amounts which are less than fifteen (15) days Overdue, in which case, no interest shall be paid unless the Contractor so demands.
3. Canada shall not be liable to pay interest where Canada is not responsible for the delay in paying the Contractor.

GC 5.5 Payment in the Event of Termination

1. If the Contract is terminated pursuant to GC 7.4, Canada shall pay the Contractor:
 - (a) an amount, as agreed upon by the Contractor and the Departmental Representative, for all Labour, Plant and Material performed, used or supplied by the Contractor as at the date of termination plus
 - (i) any fully supported termination costs incurred by the Contractor, less
 - (ii) any amounts payable to or costs and damages claimed by Canada or by a Claimant, against the Contractor; or
 - (b) failing such an agreement, an amount calculated in accordance with GC 5.7.2.

GC 5.6 Final Completion

1. A Certificate of Completion shall be issued to the Contractor on the date on which the Work has been completed and the Contractor has complied with the Contract and all orders and directions made pursuant thereto, all to the satisfaction of the Departmental Representative.
2. Where the Contract is, in whole or in part, a Unit Price Arrangement, the Departmental Representative shall, at the same time as the issuance of the Certificate of Completion, issue a Certificate of Measurement setting out the Authorized Quantities used or employed in respect of the classes and units set out in the Price Table under the BID AND ACCEPTANCE FORM and any subsequent amendments thereto, such certificate to be binding upon the Contractor and Canada.

GC 5.7 Determination of Price

1. By mutual agreement:
 - (a) where a Lump Sum Arrangement applies to the Contract or a part thereof, the price of any change shall be the aggregate estimated cost of Labour, Plant and Material that is required for the change as agreed upon in writing by the Contractor and Canada, and include an allowance for overhead, margin and the risk of undertaking the work within the stipulated amount;
 - (b) where a Unit Price Arrangement applies to the Contract or a part thereof, the Contractor and Canada may, by agreement in writing, add Items, Units of Measurement, Estimated Total Quantities and Price Per Units to the Price Table;
 - (c) a Price Per Unit referred to in GC 5.7.1 (b) shall be determined on the basis of the aggregate estimated cost of Labour, Plant and Material that is required for the additional Item as agreed upon by the Contractor and Canada, and include an allowance for overhead, margin and the risk of undertaking the work;

GENERAL CONDITIONS FOR MINOR WORKS (Continued)

- (d) to facilitate approval of the price of the additional Item, the Contractor shall submit a cost estimate breakdown identifying, as a minimum, the estimated cost of Labour, Plant, Material, each subcontract amount, and the amount of the appropriate percentage allowance;
- (e) if no agreement can be reached as contemplated in GC5.7.1 (a), the price shall be determined in accordance with GC 5.7.2; and
- (f) if no agreement can be reached as contemplated in GC 5.7.1 (b) and GC 5.7.1 (c), the Departmental Representative shall determine the Class and the Unit of Measurement of the Item of Labour, Plant or Material and the Price Per Unit shall be determined in accordance with GC 5.7.2.

2. Following Completion of the Additional Work

- (a) Where it is not possible to predetermine, or where there is failure to agree upon the price of a change in the Work, the price of the change shall be equal to the aggregate of:
 - (i) all reasonable and proper amounts actually expended or legally payable by the Contractor in respect of the Labour, Plant and Material that fall within one of the classes of expenditure described in GC 5.7.2(b), that are directly attributable to the performance of the Contract; plus
 - (ii) an allowance for profit and all other expenditures or costs equal to 10 percent of the sum of the amounts referred to in GC 5.7.2 (a)(i); plus
 - (iii) interest, if any, paid by the Contractor on the amounts determined under GC 5.7.2 (a)(i) and (ii), calculated in accordance with GC 5.4.
- (b) The cost of Labour, Plant and Material referred to in GC 5.7.2 (a) shall be limited to the following categories of expenditure:
 - (i) payments to Subcontractors and suppliers;
 - (ii) wages, salaries and traveling expenses of employees of the Contractor located at the site of the Work and that portion of wages, salaries, bonuses, living and traveling expenses of personnel of the Contractor generally employed at the head office or at a general office of the Contractor provided they are actually and properly engaged on the Work under the Contract;
 - (iii) assessments payable under any statutory authority relating to workers' compensation, employment insurance, pension plan or holidays with pay, provincial health or insurance plans, environmental reviews, and GST/HST collection costs;
 - (iv) rent that is paid for Plant, or an amount equivalent to the said rent if the Plant is owned by the Contractor, that is necessary for and used in the performance of the Work, if the rent or the equivalent amount is reasonable and use of that Plant had been approved by the Departmental Representative;
 - (v) payments for maintaining and operating Plant necessary for and used in the performance of the Work, and payments for effecting repairs thereto that, in the opinion of the Departmental Representative, are necessary for the proper performance of the Contract, other than payments for any repairs to the Plant arising out of defects existing before its allocation to the Work;
 - (vi) payments for Material that is necessary for and incorporated in the Work, or that is necessary for and consumed in the performance of the Contract;
 - (vii) payments for preparation, delivery, handling, erection, installation, inspection, protection and removal of the Plant and Material necessary for and used in the performance of the Contract; and
 - (viii) any other payments made by the Contractor with the approval of the Departmental Representative that are necessary for the performance of the Contract in accordance with the Contract Documents.

GC 5.8 Claims Against and Obligations of the Contractor or Subcontractor

GENERAL CONDITIONS FOR MINOR WORKS (Continued)

1. The Contractor shall ensure that all its lawful obligations arising out of the performance of the Work are discharged and satisfied at least as often as the Contract requires Canada to pay the Contractor. The Contractor shall provide the Departmental Representative with a Statutory Declaration, as referred to in GC 5.2.2. If any third party claims and outstanding obligations exist under the Contract, a Statutory Declaration shall also be accompanied by letter documentation that clearly identifies the existence and condition of any third party disputed claims and outstanding obligations.
2. In order to discharge lawful obligations of and satisfy lawful claims against the Contractor or a Subcontractor arising out of the performance of the Work, Canada may:
 - (a) pay an amount from money that is due and payable to the Contractor pursuant to the Contract directly to the claimant against the Contractor or the Subcontractor; or
 - (b) withhold from any amount that is due and payable to the Contractor pursuant to the Contract the full amount of the claim or any portion thereof. Monies withheld for this purpose shall not be subject to any interest payment in the event such claims are rejected.
3. The amount referred to in GC 5.8.2 (a) shall be that amount which the Contractor would have been obliged to pay to such claimant had the provisions of the Provincial or Territorial lien legislation, or in the province of Quebec, the law relating to mortgage, been applicable to the Work. Any such claimant need not comply with the provisions of such legislation setting out the steps by way of notice, registration, or otherwise as might have been necessary to preserve or perfect any claim for lien or mortgage which the claimant might have had.
4. For the purposes of GC 5.8, a claim shall be considered lawful when it is so determined:
 - (a) by a court of competent jurisdiction;
 - (b) by an arbitrator duly appointed to arbitrate the said claim; or
 - (c) by written notice delivered to the Departmental Representative and signed by the Contractor authorizing payment of the said claim(s).
5. A payment made pursuant to GC 5.8.2 is, to the extent of the payment, a discharge of Canada's liability to the Contractor under the Contract and may be deducted from any amount payable to the Contractor under the Contract.
6. GC 5.8.2 shall only apply to claims and obligations where:
 - (a) the notification of which has set forth the amount claimed to be owing and the person who by Contract is primarily liable;
 - (b) the notification or a copy of the notification was received by the Departmental Representative in writing before final payment is made to the Contractor and within one hundred and twenty (120) days of the date on which the claimant:
 - (i) should have been paid in full under the claimant's Contract with the Contractor or Subcontractor where the claim is for money that was lawfully required to be held back from the claimant; or
 - (ii) performed the last of the labour or furnished the last of the Plant or Material pursuant to the claimant's Contract with the Contractor or Subcontractor where the claim is not for money referred to in GC 5.8.6 (b)(i); and
 - (c) the proceedings to determine the right to payment for the claim shall have commenced within one year from the date that the notice referred to in GC 5.8.6 (b) was received by the Department Representative.
7. The Departmental Representative shall inform the Contractor in writing of receipt of any notification of claim and of the intention of Canada to withhold funds pursuant to GC 5.8.2. The Contractor may, at any time thereafter and until payment is made to the claimant, post with Canada, security in the form of a Claimant's Payment Bond acceptable to Canada and in an

GENERAL CONDITIONS FOR MINOR WORKS (Continued)

amount equal to the value of the said claim. Upon receipt of such security Canada shall release to the Contractor any funds which would be otherwise payable to the Contractor, that were withheld pursuant to the provisions of GC 5.8.2.

GC 6 CHANGES IN THE WORK

GC 6.1 Changes in the Work

1. Canada shall have the right to order additional Work, dispense with, or change the whole or any part of the Work described in the Drawings and Specifications or Scope of the Work.
2. The Departmental Representative shall decide whether anything done or not done as a result of directions given under GC 6.1.1 has increased or decreased the cost of the Work to the Contractor and where the cost of the Work has increased or decreased, the amount payable under the Contract shall be increased or decreased by an amount calculated in accordance with GC5.7.
3. Any change in the terms of the Contract, other than changes that may be ordered by Canada or the Departmental Representative pursuant to GC 6.1.1, may be made only by agreement in writing between Canada and the Contractor.

GC 6.2 Changes in Subsurface Conditions and Delays by Canada

1. No extra payment shall be made to the Contractor for any extra expense, loss or damage for any reason unless Canada shall certify that such extra expense, loss or damage is directly attributable to:
 - (a) a substantial difference between the subsurface conditions as indicated in the Drawings and Specifications or Scope of Work and the actual conditions found at the site of the Work; or
 - (b) the neglect or delay by Canada, occurring after the date of award of the Contract:
 - (i) in providing any information or the doing of any act which Canada is required expressly by the Contract to do or as required by a known custom of the trade; or
 - (ii) in suspending the Work pursuant to GC 7.3.
2. The Contractor shall, within ten (10) days immediately after encountering such subsurface conditions or such neglect or delay, give written notice to the Departmental Representative of a claim for such extra expense, loss or damage. Failure to provide such written notice shall render the claim null and void.
3. The amount of any extra payment made under this section shall be calculated in accordance with GC 5.7.
4. If, in the opinion of the Departmental Representative, any difference in subsurface conditions referred to in GC 6.2.1 results in a savings to the Contractor, the amount of said savings shall be deducted from the Contract Amount owing to the Contractor.

GC 6.3 Extension of Time

1. Upon written application by the Contractor made before the date fixed for the completion of the Work, Canada may extend the time for completion of the Work if, in the opinion of Canada causes beyond the control of the Contractor have delayed its completion.
2. If the Contractor does not complete the Work by the day fixed for its completion, but completes it thereafter, the Contractor shall:

GENERAL CONDITIONS FOR MINOR WORKS (Continued)

- (a) pay all Canada's inspection costs relating to the Work incurred after the stipulated completion date; and
- (b) compensate Canada for any loss or damage resulting from the failure by the Contractor to complete the Work by the completion date fixed by the Contract.

Unless, in the opinion of Canada, such delay was due to causes beyond the control of the Contractor or it is in the public interest to waive the whole or any part of the payment.

GC 7 DEFAULT, SUSPENSION OR TERMINATION OF CONTRACT

GC 7.1 Taking the Work Out of the Contractor's Hands

1. By giving notice in writing to the Contractor, Canada may take all or any part of the Work out of the Contractor's hands, and may employ such means as Canada sees fit to have the Work completed if the Contractor:
 - (a) fails to remedy any delay in the commencement or default in the execution of the Work to the satisfaction of the Departmental Representative within six (6) days of Canada giving written notice to the Contractor to do so;
 - (b) defaults in the completion of any part of the Work within the time fixed by the Contract for its completion;
 - (c) becomes insolvent or commits an act of bankruptcy and has neither made a proposal to its creditors nor filed a notice of intention to make such a proposal pursuant to the *Bankruptcy and Insolvency Act*;
 - (d) abandons the Work;
 - (e) makes an assignment contrary to GC 1.3; and or
 - (f) otherwise fails to observe or perform any of the provisions of the Contract.
2. If the whole or any part of the Work is taken out of the Contractor's hands, the Contractor's right to any further payment that is due or accruing due under the Contract is extinguished.
3. The Contractor shall be liable to pay Canada, upon demand, an amount that is equal to the sum of all losses and damages incurred or sustained by Canada in respect of the Contractor's failure to complete the Work.
4. If the whole or any part of the Work that is taken out of the Contractor's hands pursuant to GC 7.1.1 is completed by Canada, the Departmental Representative shall calculate the amount, if any, of the holdback or progress claims that had accrued and was due prior to the date on which the Work was taken out of the Contractor's hands.
5. If it is determined that there is an amount that is not required for the purposes of having the Work performed or of compensating Canada for any other loss or damage incurred or sustained by reason of the Contractor's default, Canada may then pay the Contractor the amount determined not to be required pursuant to GC 7.1.4.

GC 7.2 Effect of Taking the Work Out of the Contractor's Hands

1. The taking of the Work or part thereof out of the Contractor's hands pursuant to GC 7.1.1 does not operate so as to relieve or discharge the Contractor from any obligations under the Contract or imposed upon the Contractor by law except the obligation to complete the performance of that part of the Work that was taken out of the Contractor's hands.
2. All Plant and Material and the interest of the Contractor in all real property, licenses, powers and privileges acquired, used, provided or consumed by the Contractor under the Contract shall continue to be the property of Canada without compensation to the Contractor.

GENERAL CONDITIONS FOR MINOR WORKS (Continued)

3. When the Departmental Representative certifies that any Plant, Material or any interest of the Contractor referred to in GC 7.2, is no longer required for the purpose of the Work, or that it is not in the interests of Canada to retain that Plant, Material or interest, it shall revert to the Contractor.

GC 7.3 Suspension of the Contract

1. Canada may, upon giving notice in writing to the Contractor, suspend the performance of the Work at any time. The Contractor shall comply with such notice immediately, subject to any conditions that may be stipulated in the notice.
2. If Canada suspends the Work for thirty (30) days or less the Contractor shall, subject to its remedy under GC 5.7, complete the Work when called upon to do so. If Canada suspends the Work for a period in excess of thirty (30) days, the Contractor may request that Canada terminate the Contract pursuant to GC 7.4.
3. It is the responsibility of the Contractor to mitigate all costs during the suspension period.

GC 7.4 Termination of the Contract

1. Canada may terminate the Contract at any time by giving notice of termination in writing to the Contractor and upon receipt of such notice the Contractor shall cease all operations in performance of the Contract, subject to any conditions that may be stipulated in the notice.
2. Termination under GC 7.4.1 shall not relieve the Contractor of any legal or contractual obligations other than that portion of Work that remains to be completed at the time of the termination.
3. Payment, in event of termination under this subsection, shall be made pursuant to the provision of GC 5.5.

GC 8 DISPUTE RESOLUTION

1. The Contractor may, within 10 days after the communication to the Contractor of any decision or direction referred to in GC2.1(b) and GC6.1, protest that decision or direction.
2. A protest referred to in GC8.1 shall be in writing, contain full reasons for the protest, be signed by the Contractor and be given to Canada.
3. If the Contractor gives a protest pursuant to GC8.2, any compliance by the Contractor with the decision or direction that was protested shall not be construed as an admission by the Contractor of the correctness of that decision or direction, or prevent the Contractor from taking whatever action the Contractor considers appropriate in the circumstances.
4. The giving of a protest by the Contractor pursuant to GC8.2 shall not relieve the Contractor from complying with the decision or direction that is the subject of the protest.
5. Subject to GC8.6, the Contractor shall take any action referred to in GC8.3 within 3 months after the date of the Certificate of Completion referred to in GC5.6 and not afterwards, except where it is otherwise provided by law.
6. The Contractor shall take any action referred to in GC8.3 resulting from a direction under GC3.4, within 3 months after the expiry of a warranty or guarantee period and not afterwards, except where it is otherwise provided by law.

GENERAL CONDITIONS FOR MINOR WORKS (Continued)

7. Subject to GC8.8, if Canada determines that the Contractor's protest is justified, Canada shall pay the Contractor the cost of the additional labour, Plant and Material necessarily incurred by the Contractor in carrying out the protested decision or direction.
8. Costs referred to in GC8.7 shall be calculated in accordance with GC5.7.

GC 9 INDEMNIFICATION AND INSURANCE

GC 9.1 Indemnification

1. The Contractor shall indemnify and save harmless Canada, its servants, agents and all those for whom Canada may be, in law, responsible, from and against all claims, demands, losses, damages, costs and legal proceedings by whomever made, sustained, brought or prosecuted, and in any manner based upon, occasioned by or attributed to the activities of the Contractor, the Contractor's employees, agents or persons for whom the Contractor is, in law, responsible for the performance or purported performance of the Contract, including an infringement or alleged infringement of a patent of invention or any other kind of intellectual property.
2. For the purpose of GC 9.1.1, activities include any act improperly carried out and any omission or delay in carrying out an act.
3. The Contractor's liability to indemnify or reimburse Canada under the Contract shall not affect or prejudice Canada from exercising any rights available to Canada at law or in equity.

GC 9.2 Insurance Contracts

1. The Contractor shall, at the Contractor's expense, obtain and maintain insurance contracts in respect of the work and shall provide evidence thereof to Canada in accordance with the requirements of the INSURANCE TERMS.
2. The insurance contracts referred to in GC 9.2.1 shall:
 - (a) be in a form, of the nature, in the amounts, for the periods and containing the terms and conditions specified in INSURANCE TERMS; and
 - (b) provide for the payment of claims under such insurance contracts in accordance with GC 9.3.

GC 9.3 Insurance Proceeds

1. In the case of a claim payable under a Builders Risk/Installation (All Risks) insurance contract maintained by the Contractor pursuant to GC 9.2, the proceeds of the claim shall be paid directly to Canada, and
 - (a) the monies so paid shall be held by Canada for the purposes of the Contract, or
 - (b) if Canada elects, shall be retained by Canada, in which event they vest in Canada absolutely.
2. In the case of a claim payable under a General Liability insurance contract maintained by the Contractor pursuant to GC 9.2, the proceeds of the claim shall be paid by the insurer directly to the claimant.
3. If an election is made pursuant to GC 9.3.1, Canada may cause an audit to be made of the accounts of the Contractor and of Canada in respect of the part of the work that was lost, damaged or destroyed for the purpose of establishing the difference, if any, between
 - (a) the aggregate of the amount of the loss or damage suffered or sustained by Canada, including any costs incurred in respect of the clearing and cleaning of the Work and its

GENERAL CONDITIONS FOR MINOR WORKS (Continued)

- site and any other amount that is payable by the Contractor to Canada under the Contract, minus any monies retained pursuant to GC 9.3.1 (b); and
- (b) the aggregate of the amounts payable by Canada to the Contractor pursuant to the Contract up to the date of the loss or damage.
4. A difference that is established pursuant to GC 9.3.3 shall be paid forthwith by the party who is determined by the audit to be the debtor to the party who is determined by the audit to be the creditor.
 5. When payment of a deficiency has been made pursuant to GC 9.3.4, all rights and obligations of Canada and the Contractor under the Contract shall, with respect only to the part of the work that was the subject of the audit referred to in GC 9.3.3, be deemed to have been expended and discharged.
 6. If an election is not made pursuant to GC 9.3.1 (b), the Contractor shall, subject to GC 9.3.7, clear and clean the work and its site and restore and replace the part of the work that was lost, damaged or destroyed at the Contractor's expense as if that part of the work had not yet been performed.
 7. When the Contractor clears and cleans the Work and its site and restores and replaces the work referred to in GC 9.3.6, Canada shall pay the Contractor out of the monies referred to in GC 9.3.1 so far as they will thereon to extend.
 8. Subject to GC 9.3.7, payment by Canada pursuant to GC 9.3.7 shall be made in accordance with the Contract but the amount of each payment shall be 100 percent of the amount claimed notwithstanding GC 5.3 a) and b).



Appendix "E"

PLANS & TECHICAL SPECIFICATIONS



APPENDIX E TECHNICAL SPECIFICATIONS

1 Project Title

REPAIR OF THE SLATS OF THE SLATTED FLOORS IN ROOMS C-101, C-102 AND C-103 OF THE SWINE COMPLEX

2 Context

Building 7 is the swine complex of Agriculture and Agri-Food Canada's Research and Development Centre located at 2000 College Street in Sherbrooke (Sherbrooke RDC). It is composed of eight (8) sectors (A to H) built in 1996–1997. Sector C is reserved for sow gestation and comprises four (4) rooms (C-101, C-102, C-103 and C-104), each measuring approximately 15 m x 18 m.

Each room in Sector C has a concrete slatted floor that empties into four (4) channels: one (1) channel along each of the east and west walls of the room and two (2) middle channels in the centre of the room. Each channel is covered with a prefabricated concrete slat floor. Over time, the foundations of the channel sleeper walls upon which the prefabricated slats are laid have eroded and the slats are no longer supported all along the length of the channels. The slats are unstable and are no longer level with each other.

3 General

3.1 Summary of Work covered by Contract Documents

The Work involves removing existing concrete slabs from the affected rooms, redoing the foundations of the concrete sleeper walls, installing steel angles and reinstalling existing slabs, and replacing damaged slabs to provide a stable and uniform floor on the entire surface of slatted floors.

3.2 Regulatory requirements

3.2.1 Codes, standards and other reference documents

The Work must be performed in accordance with the following documents:

1. National Building Code of Canada (NBCC), latest edition;
2. National Farm Building Code (NFBC), latest edition;
3. *Canadian Environmental Protection Act*, latest edition;
4. *Quebec Environmental Quality Act* (R.S.Q., c. Q-2), most recent edition;

3.2.2 Quality Control

1. Concrete Work must be inspected according to Standard CSA A23.1.
2. If the Contractor covers or permits to be covered Work that has been designated for special tests, inspections or approvals before such is made, the Contractor must



uncover such Work, have inspections or tests satisfactorily completed and make good such Work.

3. AAFC may order any part of the Work to be examined if the Work is suspected not to be in accordance with Contract Documents. If, upon examination such Work is found not in accordance with the Contract Documents, the Contractor must correct such Work and pay the examination and correction costs.

3.2.3 Independent inspection agencies

1. AAFC reserves the right to use any independent testing and inspection agencies it deems necessary to ensure the quality of the Work.
2. Employment of inspection/testing agencies does not relax responsibility to perform Work in accordance with Contract Documents.
3. If defects are found during testing or inspections, the Contractor shall correct defects as directed by the Project Authority at no additional cost to AAFC.

3.3 Schedule of Work

1. The rooms will be delivered to the Contractor one at a time in the following order: C-102, C-101 and C-103. The Sherbrooke RDC must be able to use the other rooms during the Work in order to ensure continuance of its research activities.
2. C-101 and C-102 must be delivered by August 3, 2018 at the latest.
3. All Work must be completed by August 31, 2018.
4. The Contractor is responsible for providing the AAFC Project Authority with the schedule at the start of the Work and for updating it upon request.

3.4 Contractor's Use of Premises

1. The swine complex is subject to a biosecurity protocol provided as an annex. With the exception of Room C-101, C-102 or C-103, which is delivered to the Contractor and forms its work site (5.2.2), the protocol shall apply at all times throughout the building.
2. The site will be delivered in 3 separate phases (one phase for each room). The Contractor must coordinate access to and use of spaces with the foreman of the swine complex.
3. The Work must proceed in such a way that the building remains protected against damage caused by demolition work.
4. The Contractor must remove or alter existing work to prevent injury or damage to portions of existing work which remain.
5. The Contractor must maintain access to the site for the fire department at all times.



3.5 AAFC Site Occupancy

1. The existing building must remain in operation throughout the entire work period, 24 hours a day, seven (7) days a week. This condition is essential; therefore, care must be taken to minimize disruption to AAFC operations.
2. The Contractor must cooperate with AAFC to minimize conflicts and to facilitate Owner use of the premises.

4 Performance

4.1 Performance of Work by the Contractor

Each of the following sections must include all standard materials and usage inherent to the scope of the Work to be performed by the Contractor unless explicitly excluded. The Contractor will perform the Work as follows, but not limited to:

1. The Contractor must refer to the manufacturer's installation instructions when these are available.
2. The Contractor must apply best construction practices when the manufacturer's instructions are not available.
3. The Contractor must take great care not to leave any waste in the gutter that could hinder the operation of pumps downstream.
4. The Contractor must provide or furnish, and pay for, all labour, products, materials, tools, construction equipment, lighting, transportation, and other facilities and services necessary for the performance of the Work in accordance with the Contract.
5. The Contractor must dismantle and keep the existing pens and store them on site. The fasteners will be retained for reinstallation.
6. If necessary, the Contractor will remove the pulleys for the manure scrapers and the motors. The parts will be retained for reinstallation.
7. The Contractor must salvage the existing steel plates covering the drains.
8. Existing prefabricated concrete slats will be removed and kept. Slats that are damaged or whose edges have eroded must be replaced.
 - a. It is anticipated that at least 40% of existing slats are due for replacement. For each room.
 - b. If fewer than 40% need replacing, the surplus slats will be returned to AAFC.
 - c. If, following the count approved by the Project Authority, more than 40% of the slats need replacing, the additional slats will be replaced at unit price submitted by the Contractor, under to AAFC approval.
 - d. Slats damaged during the Work by the Contractor or the Contractor's Subcontractors must be replaced at the Contractor's expense. AAFC or it's substitute will be inspecting the Contractor method.
 - e. From the unusable slats, the Project Authority reserves the right to choose slats to be retained for another purpose. These slats will be returned to AAFC and left on site.
 - f. The Contractor must dispose of all unusable slats that are not retained by AAFC in accordance with Article 4.11 Cleaning.
9. The Contractor must cover the channel drains to catch all materials that could end up in the channels and later in the drainage system.



10. The foundations of the channel sleeper walls supporting the slats will be cleaned and made smooth.
11. The Contractor must use a concrete coating to even out the surface of the foundations so that they are level with each other.
12. The Contractor must install the stainless steel angle on the concrete foundation and select a fastening device that will leave the surface of the angle smooth and consistent along its length.
13. At the end of the Work, the Contractor must clean the channels before reinstalling the slats.
14. If applicable, the Contractor must reinstall the pulleys for the manure scrapers and the motor. AAFC staff will validate the proper operation of these systems.
15. The Contractor must reinstall the existing slats or the new replacement slats and ensure that they rest well on the support surface and do not move. The slats must be fitted between the different channels and the existing concrete floors. If shims are used, the Contractor must ensure that they are well secured. The slats must be level with the existing concrete floor or with the slats of the neighbouring channel so that pigs' hooves cannot catch on them.
16. The Contractor must reinstall the steel plates covering the drains.
17. The Contractor must reinstall the pens and other operating equipment removed at the start of the Work.
18. The Contractor must clean the site and ensure that materials are not found in the channels.
19. The Contractor must coordinate with the foreman of the swine complex to return rooms in which the Work has been completed so that the latter can make the next room available.

4.2 Work by Others

1. As appropriate, AAFC may assign other contractors work not scheduled in the Contract.
2. The Contractor must coordinate the Contractor's work with that of the other contractors and ensure that the connections expected or indicated in the Contract Documents can be made. If any part of the Work under this Contract depends for its proper performance or result upon the Work of another Contractor, the Contractor must report promptly to the Project Authority, in writing, any defects which may interfere with the proper performance of the Work.
3. The Contractor will provide to the other contractors the assistance and services that the Contractor normally provides to the Contractor's Subcontractors and with them take on the Project Authority's obligations as set out in the *Act respecting occupational health and safety*.

5 Site Works

5.1 Site Access

1. Access to demolition and construction zones as well as exits must be controlled to limit exposure of vehicles and unauthorized persons to dangerous conditions.
2. On-site sale of salvaged materials and construction materials is strictly forbidden.
3. Working hours are from 7 a.m. to 5 p.m.
4. Signage at the edge of the site or on AAFC premises will not be tolerated.



5.2 Special Requirements

1. Access to Building 7 is governed by a biosecurity protocol (Appendix 3). Should the Contractor, the Contractor's employees or the Contractor's Subcontractors require access to areas in operation in any part of the building, with the exception of the one described in 5.2.2, it is the responsibility of the Contractor to ensure that this protocol is followed.
2. Is defined as the Contractor's site the room delivered to the Contractor by AAFC. Only one room will be delivered to the contractor at a time. When a room is delivered to the Contractor, it will be:
 1. Washed;
 2. The entrance door of the room opening onto the Sector C hallway will be locked by AAFC employees; no employees of the contractor or its subcontractors will have access to the interior of the swine complex;
 3. The Contractor will be able to enter the site by a door leading directly outside;
 4. The biosecurity protocol will not apply to this room for the duration of the Project and for as long as the room has not been delivered to AAFC and disinfected by the latter.
3. AAFC will provide guard services at all times to ensure the security of these facilities while the work is being performed.
4. AAFC is not responsible for the security of material left on site by the Contractor or Subcontractors.

5.3 Use of Site and Facilities

1. The Contractor must perform the Work with the least possible interference or disturbance to normal use of premises. The Contractor will make arrangements with the Project Authority to facilitate Work as stated.
2. The Contractor must maintain existing services to the building and provide for personnel and vehicle access at all times.
3. Where security is reduced by work, the Contractor will provide temporary means to maintain security of on-site goods and persons.
4. Parking lot use on the farm is authorized as specified by AAFC at no cost for the Contractor's employees and/or Subcontractors.
5. The Contractor will provide sanitary facilities for use by the Contractor's personnel and will keep facilities clean.

5.4 Smoke-free environment

1. The Contractor will comply with smoking restrictions. Smoking is not permitted inside any AAFC building or within nine (9) metres of the buildings.

5.5 Control of noise and disturbances

1. The Contractor must, in the performance of the Work, disturb as little as possible AAFC, its personnel, activities and the general public, and shall comply with the applicable municipal bylaws. The Contractor will indemnify AAFC against any actions caused by noise and disruptions or from any resulting claims.

5.6 Installation and removal of equipment



1. The Contractor must provide construction facilities in order to execute the Work expeditiously.
2. The Contractor must remove from the site all such Work after use.

5.7 Lifting equipment

1. The Contractor must provide, operate and maintain hoists required for moving of workers, materials and equipment.
2. Hoists must be operated by qualified operators.

5.8 Storage and loading area

1. The Contractor must limit work and activities to spaces designated by AAFC.
2. The Contractor must not load or permit to load any part of the Work with a weight that will endanger the Work.

5.9 Temporary Utilities

1. The Contractor must provide temporary utility controls in order to execute the Work expeditiously. The Contractor must pay all costs for installation, maintenance and removal.
2. AAFC provides electrical services to the Contractor for existing water services in each room.
3. The Contractor must provide temporary heating and ventilation required during the construction period, including attendance, maintenance and fuel.
4. The Contractor must provide and maintain temporary fire protection equipment during performance of the Work required by insurance companies having jurisdiction and by governing codes, regulations and bylaws.
5. The Contractor must remove the previously listed equipment from the site when the Work is deemed complete.

5.10 Storage of materials, products, equipment and tools

1. The Contractor must provide and maintain, in clean and orderly condition, lockable weatherproof sheds for storage of materials, products, equipment and tools.
2. The Contractor must locate materials not required to be stored in weatherproof sheds on site in a manner that causes the least interference with Work activities.

5.11 Cleaning

- .1 The Contractor is responsible for the disposal of waste at the Contractor's site; space may be designated by the AAFC Facility Manager for the installation of a container if required.
- .2 Off-site waste handling will be subject to conditions to be determined with the foreman of the swine complex or the AAFC Project Authority in order to ensure compliance with biosecurity containment conditions required in the building.
- .3 The Contractor must provide the equipment required for handling of waste inside the building.
- .4 The Contractor is responsible for cleaning the site at the end of each shift.



6 Project Meetings

6.1 Meetings and site visits

1. Site meetings will be held at the request of the Project Authority.
2. A meeting location will be made available for site meetings, to be determined by the Project Authority.
3. The Project Authority and persons accompanying the Project Authority must be permitted access to the site for visits at all times, provided that it is safe for them.

6.2 Preconstruction Meeting

1. A start-up meeting to discuss and resolve administrative procedures and responsibilities of each party will be organized by AAFC. The main representatives of AAFC, of the Contractor and of the Subcontractors must be in attendance.

7 Health & Safety

7.1 Health & Safety

1. The Contractor must manage operations so that the health and safety of the public and of the workers on site always take precedence over considerations of cost and scheduling.

7.2 Compliance Requirements

1. The Contractor must comply with all laws, regulations and standards applicable to the site and its related activities.
2. The Contractor must comply with safety regulations and established standards when hazardous or toxic materials are present at the site.
3. The Contractor must always use the most recent version of the *Safety Code for the construction industry*.

7.3 General Requirements

1. The Contractor must accept and assume all tasks and obligations normally assigned to the principal contractor under the *Act respecting occupational health and safety* (RRQ, c. S-2.2.1) and the *Safety Code for the construction industry* (S-2.1, r. 6).

7.4 Asbestos

1. A 2017 site characterization study found no asbestos-containing materials within the designated work zones. The characterization report identifying the study zones will be provided to the Contractor upon request.

7.5 Lockout



1. The Contractor, the Contractor's employees and the employees of the Contractor's Subcontractors are responsible for applying the Sherbrooke RDC's lockout procedures when required by Work. The Contractor must inform the Project Authority of the machines for which lockout procedures apply. The lockout procedure will be provided to the Contractor upon request.

7.6 Fire Permit

1. The Contractor is responsible for informing the Project Authority in advance when a fire permit is necessary for performance of Work.

8 Materials

8.1 Angles and concrete slats

1. The Contractor must carefully salvage the client's concrete slats. The slats will be reinstalled. It is anticipated that approximately 40% of existing slats have eroded and will have to be replaced during the Work.
2. Slats damaged during handling, storing or reinstallation must be replaced with no additional fees for AAFC.
3. Description:
 1. Channel slats along walls (long slats):
 - i. Number per room: 56 slats
 - ii. Length: 2440 mm (96 in.)
 - iii. Width: 610 mm (24 in.)
 - iv. Thickness: 146 mm (5 3/4 in.)
 2. Centre channel slats (short slats):
 - i. Number per room: 56 slats
 - ii. Length: 1524 mm (60 in.)
 - iii. Width: 610 mm (24 in.)
 - iv. Thickness: 95.3 mm (3 3/4 in.)
4. Replacement model
 1. Patio Drummond free-moving slats or equivalent for gestating pigs;
 2. If a replacement model is used, a list of other materials must be provided to AAFC and approved by AAFC. It must include trade names or trademarks, or the names of manufacturers or suppliers, product number, colour and size;
 3. During the bidding period, provide replacement models to the Contracting Officer in writing with complete technical data at least 5 calendar days prior to the bid closing date.
5. The Contractor must adjust the concrete of the supporting sleeper walls to obtain level finished surfaces. The shims must be stable and immobilized. The shims should be made of rigid plastic. The salvaged and relocated slats should be adjusted.
6. The angles are 10 gauge stainless steel. As shown in the plans, the total length to install per room is approximately 420 linear feet.

APPENDIX E1

PIGSTY COMPLEX: BIOSECURITY AND SECURE ENTRANCE

Biosecurity objectives :

Minimize the risk of transmission of infectious agents by humans. Humans pose a biosanitary risk for the pigsty complex, mainly as a mechanical vector by transporting infectious agents on their clothes.

Procedure :

- 1- Access to the pigsty complex can only be done through the secure entrances planned for this purpose.
- 2- Register and sign-in at the entrance and exit of building.
- 3- Remove boots (or shoes) and coats before entering secure entrance. Place on rubber carpet and hooks provided for this purpose. **Do not walk beside carpet with exterior shoes.

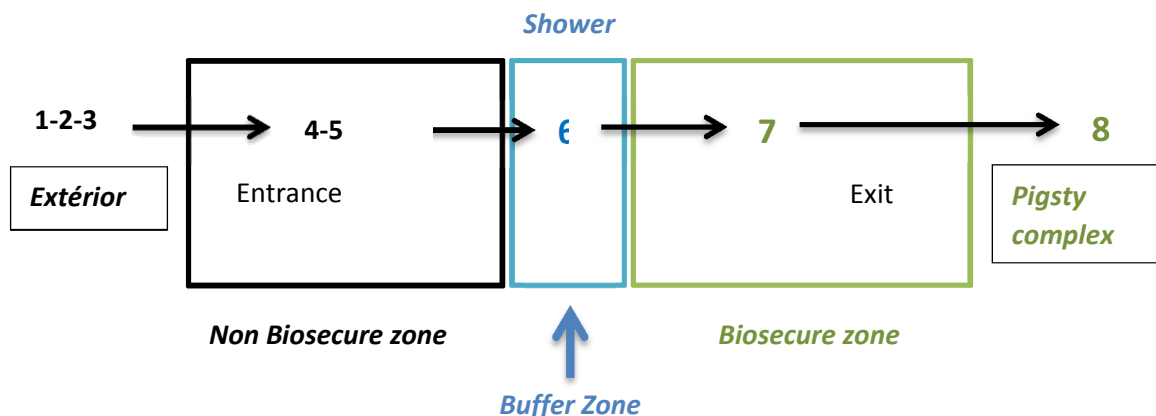

- 4- After entering secure entrance, make sure to press the red button near the door in order to lock entrance and exit doors of the secure entrance. An exterior indicator light will inform us of your presence. You just have to turn the door knob in order to deactivate latch and walk out.
- 5- Remove your clothes (socks, watch...) and deposit them in a locker. Only keep underwear. The following installations are at your disposal: lockers, shelves, mirror.
- 6- Thoroughly wash hand and arms to the elbow. Showers are mandatory for people coming from the exterior.

People that have been in contact with pigs in the last 48 hours must advise the foreman on duty before entering.

The following installations are at your disposal: showers, sink, hand towels, body soap, shampoo and towels.



- 7- Put on socks and clean overall (socks must be inside of clothing).
The following articles are at your disposal: overalls, socks, boots, latex gloves, ear plugs (if required).
- 8- Identify yourself to the foreman and advise for the reason of the visit.

**** Please remove and dispose of used work clothes and towels in the bins provided for this purpose.**

Travelling procedure between sections within the pigsty complex:

The pigsty complex is divided into multiple sectors (buildings A, B, C, D, E, F, G and H). The building is design in such a way so that some sectors can be closed off for various reasons: Exterior animals coming in with a different sanitary status, presence of a disease in a sector, particular needs for a project,... Verify with foreman the specific requirements of the sectors before entering field.

When a sector is closed off, the doors are closed and indications regarding the procedure to use is inscribed on the door. Generally, the procedure is the same as the one used for the secure entrance of the facility but there might be slight differences (wearing of a hair-cover, no need to change socks, shower,...). It is important to carefully read the signs posted on the secure entrances. Overalls of various colors (identified to each sector), socks and all security material (boots, ear plugs, hair-cover, latex gloves,...) required for that sector are available on the other side of the secure entrance.

Thank-you for your understanding!

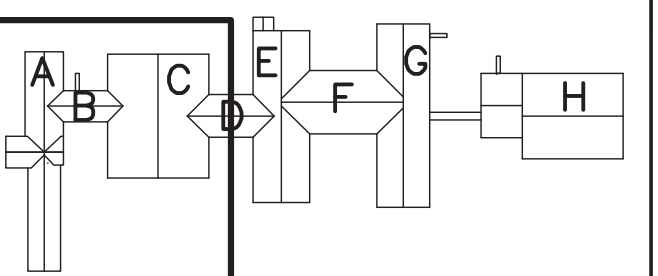
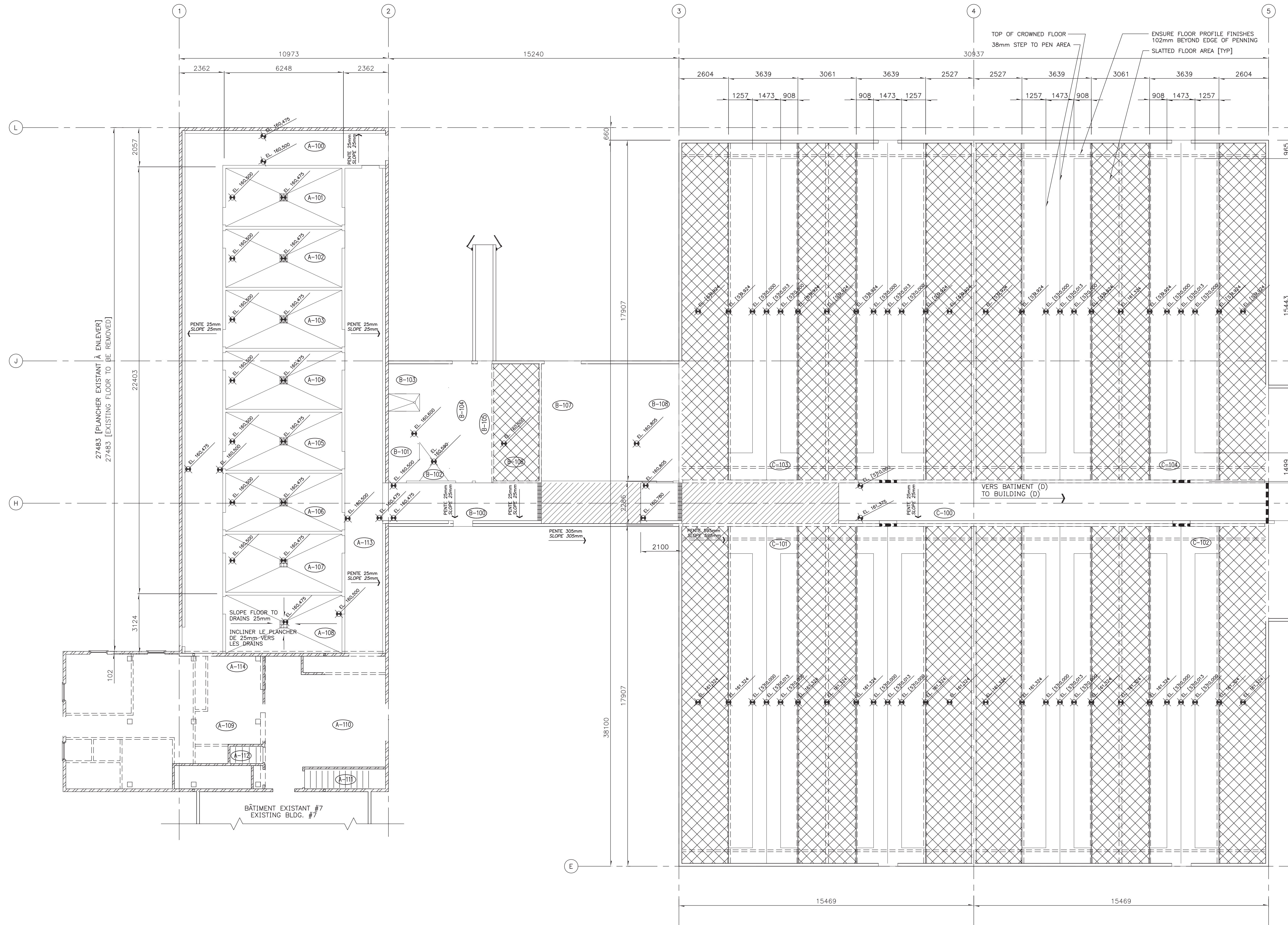

PLAN CLÉ
KEY PLAN



2	TEL QUE CONSTRUIT/ AS-BUILT	05/01/00
1	EMIS POUR CONST./CONST. ISSUE	01/04/98
0	POUR SOUMISSION/TENDER ISSUE	05/12/97

revisions	no. du detail	date
A	A detail no.	
B	B location drawing no. sur dessin no.	
C	C drawing no. dessin no.	

project **LENNOXVILLE** projet
CENTRE DE RECHERCHE ET DE DEVELOPPMENT
RESEARCH AND DEVELOPMENT CENTRE
COMPLEXE PORCIN EXPERIMENTAL
EXPERIMENTAL PORCINE COMPLEX

drawing **PLAN DE PLANCHER FINI, ÉLEVATION ET TYPE POUR LES BÂTIMENTS (A,B & C)** dessin
PLAN OF FINISHED FLOOR ELEVATIONS AND TYPES FOR BUILDINGS (A,B & C)

designed **DGH Engineering Ltd.** conçu
date **06/02/97**
drawn **T. R. Kapty** dessiné
date **06/02/97**

approved **D.G. Hodgkinson, P. Eng.** approuvé
date
Tender **Yves Carol Jean, ing.** Soumission
PWC Project Manager **Administrateur de projets IPC**

drawing number **702642-702643** no. du projet

drawing no. **QU-97153-B** no. de dessin
sheet no. **S-3.0** feuille no.

BÂTIMENT (A,B & C)
BUILDING (A,B & C)

1:100

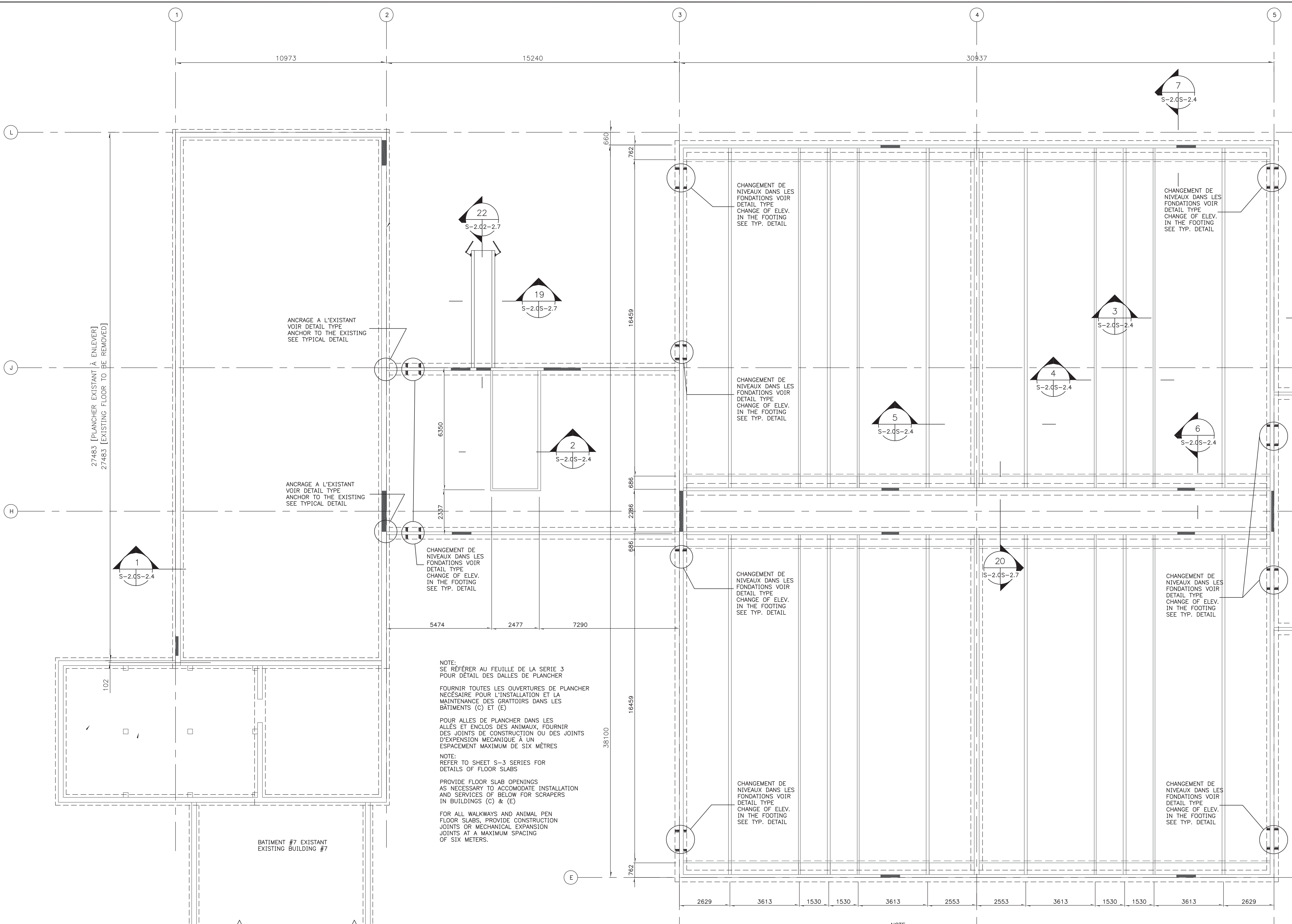

Pour la construction, les présents plans doivent absolument être consultés en parallèle avec les plans d'architecture. Vous y trouverez l'information requise pour déterminer les cotes, dimensions et niveaux de plancher. L'entrepreneur devra corriger ou reprendre à ses frais tout travail qui ne sera pas conforme à l'ensemble des plans.

For construction, these plans must absolutely be consulted in parallel with the architectural plans. You will find the required information to determine dimensions and floor levels. The Contractor will have to correct or re-do, at his own expense, all work which does not conform to all the drawings.

BÂTIMENTS (A, B & C)
BUILDINGS (A, B & C)

1:100

NOTE:
 TOUS LES FINIS DE PLANCHER DANS LES ALLÉS ET ENCLOSES D'ANIMAUX SERONT TEXTURÉS AVEC UN FINI LÉGER DE BALAI DANS LE SENS DU DRAINAGE
 FOURNI UN LIEN BRISABLE AUTOUR DE TOUS LES PLANCHERS EN LATTE PRÉFABRIQUÉ POUR PERMETTRE UN REMPLACEMENT FUTUR
 PRÉVOIR UN RECOUVREMENT DE 38mm PAR-DESSUS LES ARMATURES POUR TOUTES LES SURFACES DE BÉTON.
 JOINDRE LES DALLES DU PLANCHER AU MUR AVEC DES GOIJONS. LA DIMENSION SE L'EMPLACEMENT DES GOIJONS DOIVENT ÊTRE DIMENSIONNÉS SELON LES CHARGES.
 PLACER LE BÉTON SUR LE SOL NON REMANIÉ. TOUT REMBLAI PLACÉ SOUS LE NIVEAU DES SEMELLES DEVA ÊTRE COMPACTÉ À 98% DU PROCTOR MODIFIÉ. TOUT AUTRE REMBLAI DEVA ÊTRE COMPACTÉ À 95% DU PROCTOR MODIFIÉ.

NOTE:
 SE RÉFÉRER AU FEUILLE DE LA SERIE 3 POUR DETAIL DES DALLES DE PLANCHER
 FOURNI TOUTES LES OUVERTURES DE PLANCHER NÉCESSAIRE POUR L'INSTALLATION ET LA MAINTENANCE DES GRATTOIRS DANS LES BÂTIMENTS (C) ET (E)
 POUR ALLES DE PLANCHER DANS LES ALLÉS ET ENCLOSES DES ANIMAUX, FOURNI DES JOINTS DE CONSTRUCTION OU DES JOINTS D'EXPANSION MÉCANIQUE À UN ESPACEMENT MAXIMUM DE SIX MÈTRES
 NOTE:
 REFER TO SHEET S-3 SERIES FOR DETAILS OF FLOOR SLABS
 PROVIDE FLOOR SLAB OPENINGS AS NECESSARY TO ACCOMMODATE INSTALLATION AND SERVICES OF BELOW FOR SCRAPERS IN BUILDINGS (C) & (E)
 FOR ALL WALKWAYS AND ANIMAL PEN FLOOR SLABS, PROVIDE CONSTRUCTION JOINTS OR MECHANICAL EXPANSION JOINTS AT A MAXIMUM SPACING OF SIX METERS.

LES JOINTS ENTRE LES MURS DE 102mm ET LES PLANCHERS DEVONT ÊTRE RÉALISÉS EN UTILISANT DES CLEFS D'UNE DIMENSION MINIMALE DE 38x38mm. TOUS LES AUTRES JOINTS ENTRE LES MURS ET LES PLANCHERS SERONT RÉALISÉS EN UTILISANT DES CLEFS DE 38x89mm. LES CLEFS DEVONT ÊTRE NETTOYÉES AVANT LE BÉTONNAGE DES MURS.
 LES DIMENSIONS EXACTES DE TOUS LES GRATTOIRS DE PLANCHERS, LAMELLES ET GRILLES SERONT TRANSMISSES À L'ENTREPRENEUR AVANT LE DÉBUT DE LA CONSTRUCTION. POUR LES BESOINS DE L'ESTIMATION, LES GRATTOIRS DE PLANCHERS, GRILLES DE PLANCHERS ET LAMELLES SERONT À L'INTÉRIEUR DE 50mm DES DIMENSIONS INDICUÉES.
 UNE FINITION DE BÉTON AVEC LES TROUS DE TIRANT REMPLIS DE MORTIER EST ADÉQUATE POUR TOUS LES MURS À L'INTÉRIEUR DES BÂTIMENTS ET POUR L'EXTÉRIEUR DES RÉSERVOIRS D'ENTREPOSAGE DE PURIN. LES ZONES OÙ IL Y A DES NIDS D'ABEILLE IMPORTANTS NÉCESSITERONT L'APPLICATION DE MORTIER.

NOTE:
 ALL FINISHED FLOOR SLABS FOR ANIMAL PENS OR WALKWAYS TO BE TEXTURED WITH A LIGHT BROOM FINISH IN THE DIRECTION OF DRAINAGE. VERIFY SAMPLE FLOOR SURFACE w/OWNER.
 PROVIDE BOND BREAKER ALONG ALL PRECAST SLATS TO ALLOW FOR FUTURE REMOVAL.
 PROVIDE 38mm CLEAR CONCRETE COVER OVER ALL REINFORCING STEEL [REBAR]
 JOIN FLOOR SLABS TO WALLS WITH DRILLED IN DOWELS. SIZE & SPACING TO MATCH FLOOR SLAB
 PLACE CONCRETE ON UNDISTURBED SOIL. ANY FILL TO BE PLACED BELOW FOOTINGS IS TO BE COMPACTED TO 98% OF MODIFIED PROCTOR DENSITY. ALL OTHER FILL MAY BE COMPACTED TO 95% OF MODIFIED PROCTOR DENSITY.
 102mm THICK WALLS TO FLOOR JOINTS WILL BE KEYED TO THE FLOOR WITH NOT LESS THAN 38x38mm KEYWAYS. ALL OTHER WALL TO FLOOR JOINTS WILL BE KEYED TO THE FLOOR WITH 38x89mm KEYWAYS. CLEAN THE KEYWAYS BEFORE POURING THE WALLS.
 PRECISE DIMENSIONS OF ALL FLOOR SCRAPERS, SLATS, AND GRATES WILL BE PROVIDED TO THE CONTRACTOR PRIOR TO CONSTRUCTION. FOR ESTIMATING PURPOSES, ALL FLOOR SCRAPERS, FLOOR GRATES, AND SLATS WILL BE WITHIN 50mm OF SIZES INDICATED.
 FORM FINISH WITH GROUT APPLIED TO SNAP TIE HOLES WILL BE SUITABLE FOR ALL WALLS WITHIN THE BUILDING AND FOR THE EXTERIOR MANURE STORAGE TANK. AREAS OF VISIBLE HONEYCOMBING WILL REQUIRE GROUTING. THE FORM JOINT LINES WITH MISALIGNMENT, FLASHINGS, OR PROJECTIONS GREATER THAN 3mm WILL REQUIRE REPAIR BY GRINDING OR PARING.

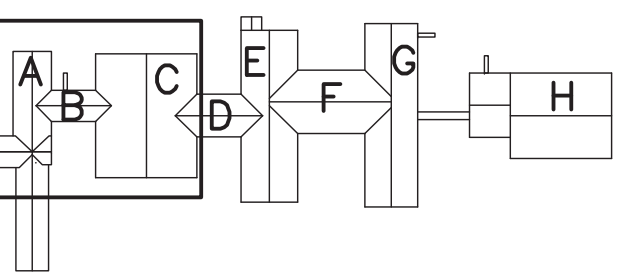

PLAN CLÉ
KEY PLAN



2	TEL QUE CONSTRUIT/ AS-BUILT	05/01/00
1	EMIS POUR CONST./CONST. ISSUE	01/04/98
0	POUR SOUMISSION/TENDER ISSUE	05/12/97

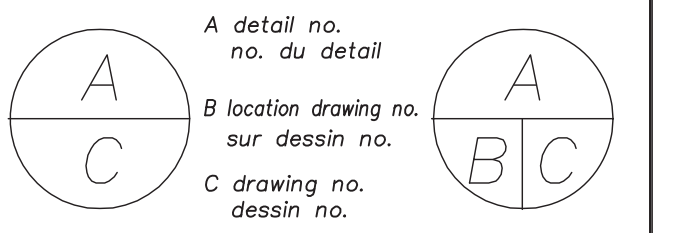

project **LENNOXVILLE** projet
 CENTRE DE RECHERCHE ET DE DEVELOPPMENT RESEARCH AND DEVELOPMENT CENTRE
COMPLEXE PORCIN EXPERIMENTAL
 EXPERIMENTAL PORCINE COMPLEX

drawing **STRUCTURE DES FONDATIONS POUR LES BATIMENTS (A,B & C)** dessin
STRUCTURAL FOUNDATIONS FOR BUILDINGS (A,B & C)

designed	conçu	
DGH Engineering Ltd.	06/02/97	
date		
drawn	dessiné	
date		
approved	approuvé	
D.G. Hodgkinson, P. Eng.		
date		
Tender	Soumission	
Yves Carol Jean, ing		
PWC Project Manager	Administrateur de projets IPC	
drawing number	no. du projet	
702642-702643		
drawing no.	no. de dessin	sheet no. feuille no.
QU-97153-B	S-2-0	

PLOT DATE: JAN 17 2000 08:52

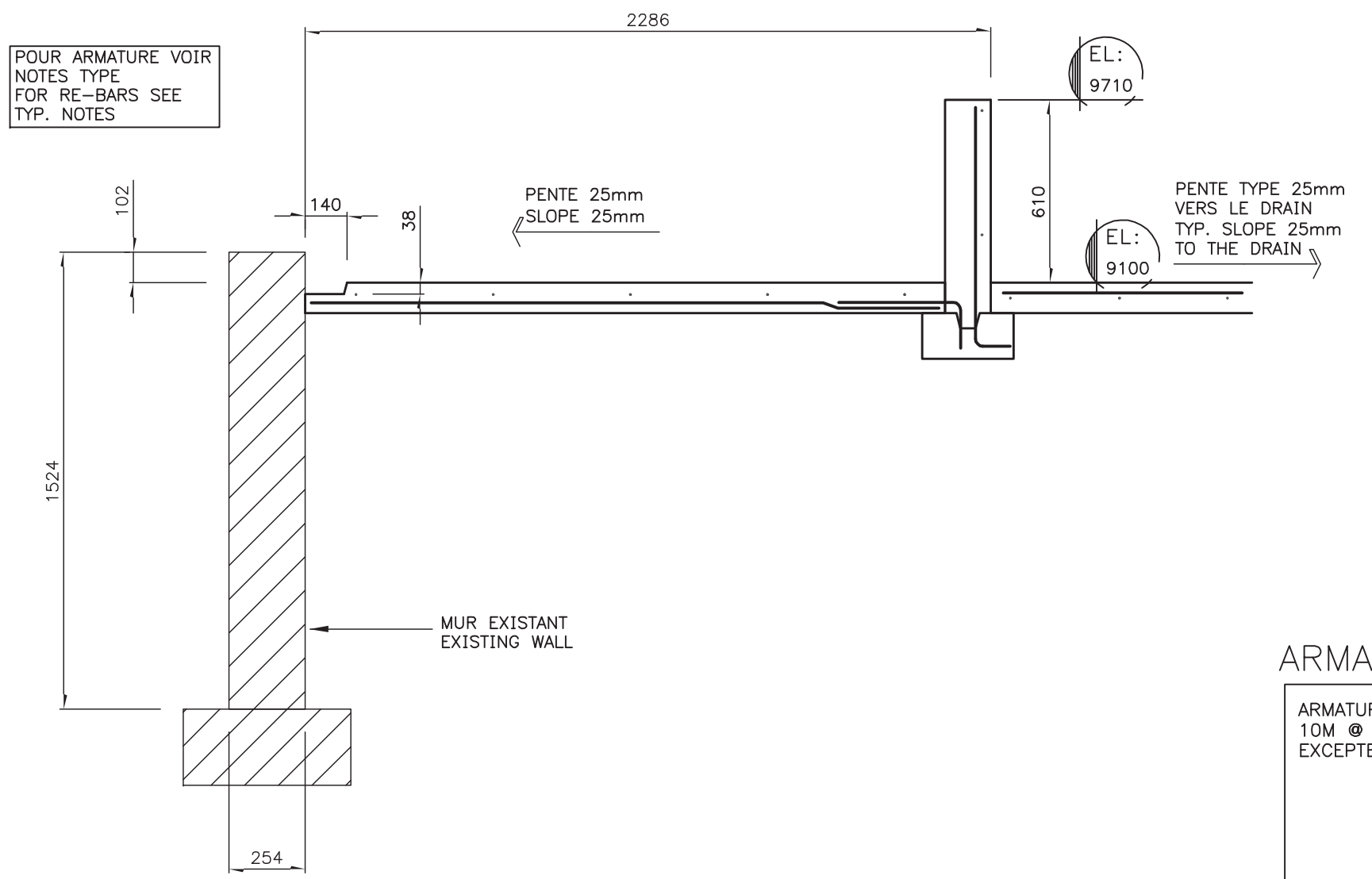

COUPE - BÂTIMENT (A)
SECTION - BUILDING (A)

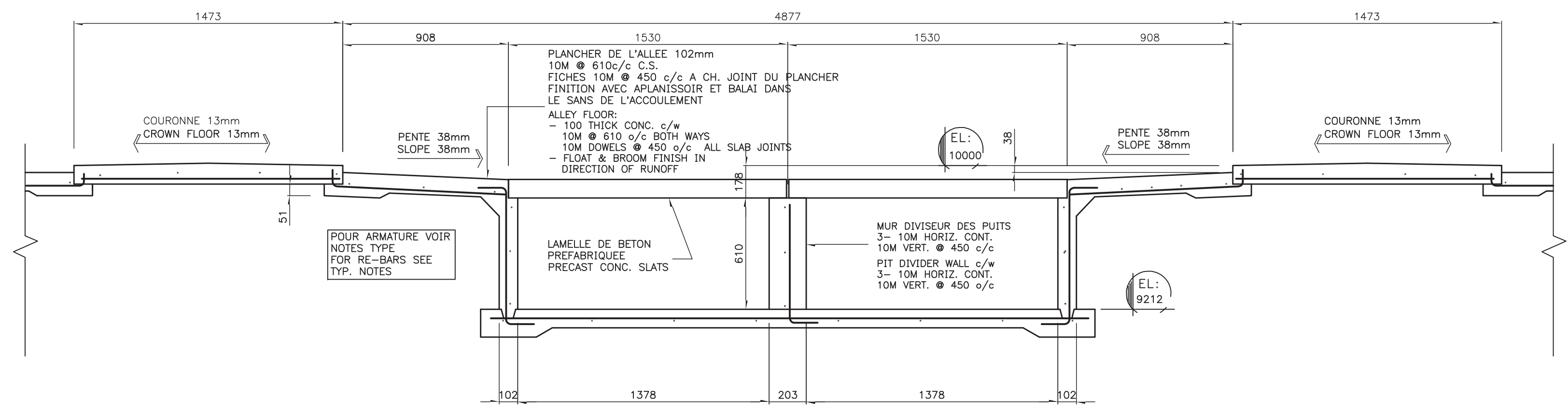
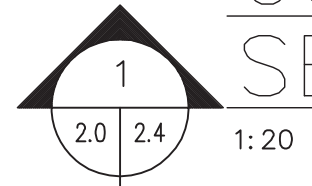

COUPE - BÂTIMENT (C)
SECTION - BUILDING (C)

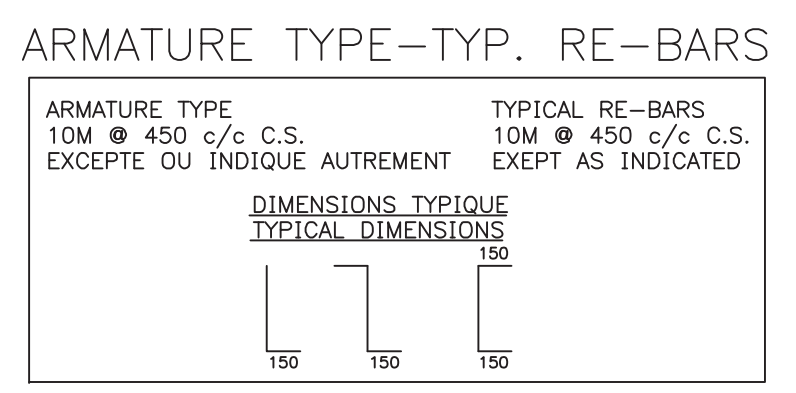
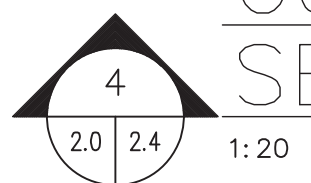

ARMATURE TYPE-TYP. RE-BARS
ARMATURE TYPE 10M @ 450 c/c C.S. EXCEPTÉ OU INDIQUÉ AUTREMENT
TYPICAL RE-BARS 10M @ 450 c/c C.S. EXCEPT AS INDICATED
DIMENSIONS TYPIQUE TYPICAL DIMENSIONS

For construction, these plans must absolutely be consulted in parallel with the architectural plans. You will find the required information to determine dimensions and floor levels. The Contractor will have to correct or re-do, at his own expense, all work which does not conform to all the drawings.
Pour la construction, les présents plans doivent absolument être consultés en parallèle avec les plans d'architecture. Vous y trouverez l'information requise pour déterminer les cotes, dimensions et niveaux de plancher. L'Entrepreneur devra corriger ou reprendre à ses frais tout travail qui ne sera pas conforme à l'ensemble des plans.

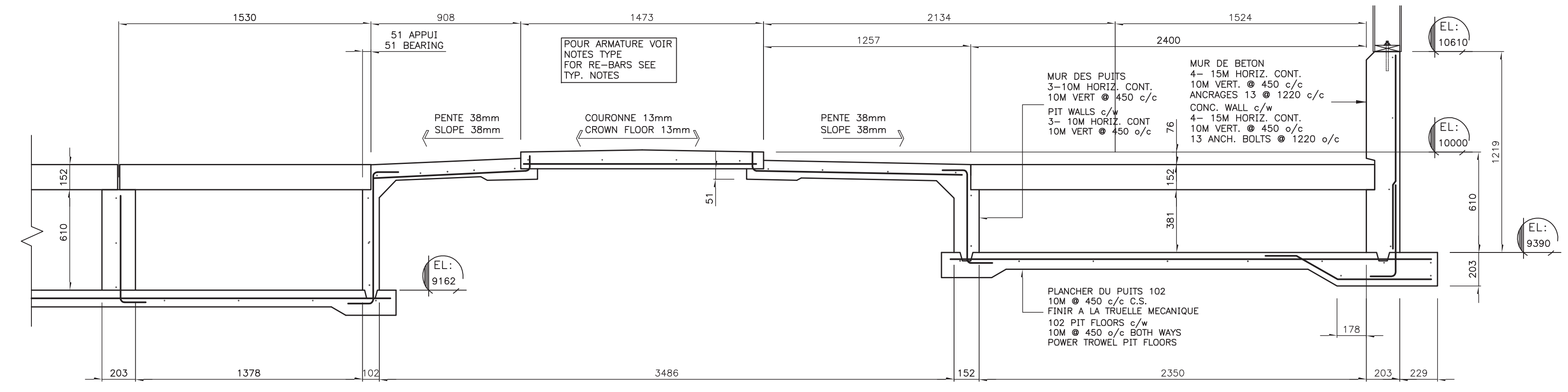

COUPE - BÂTIMENT (C)
SECTION - BUILDING (C)

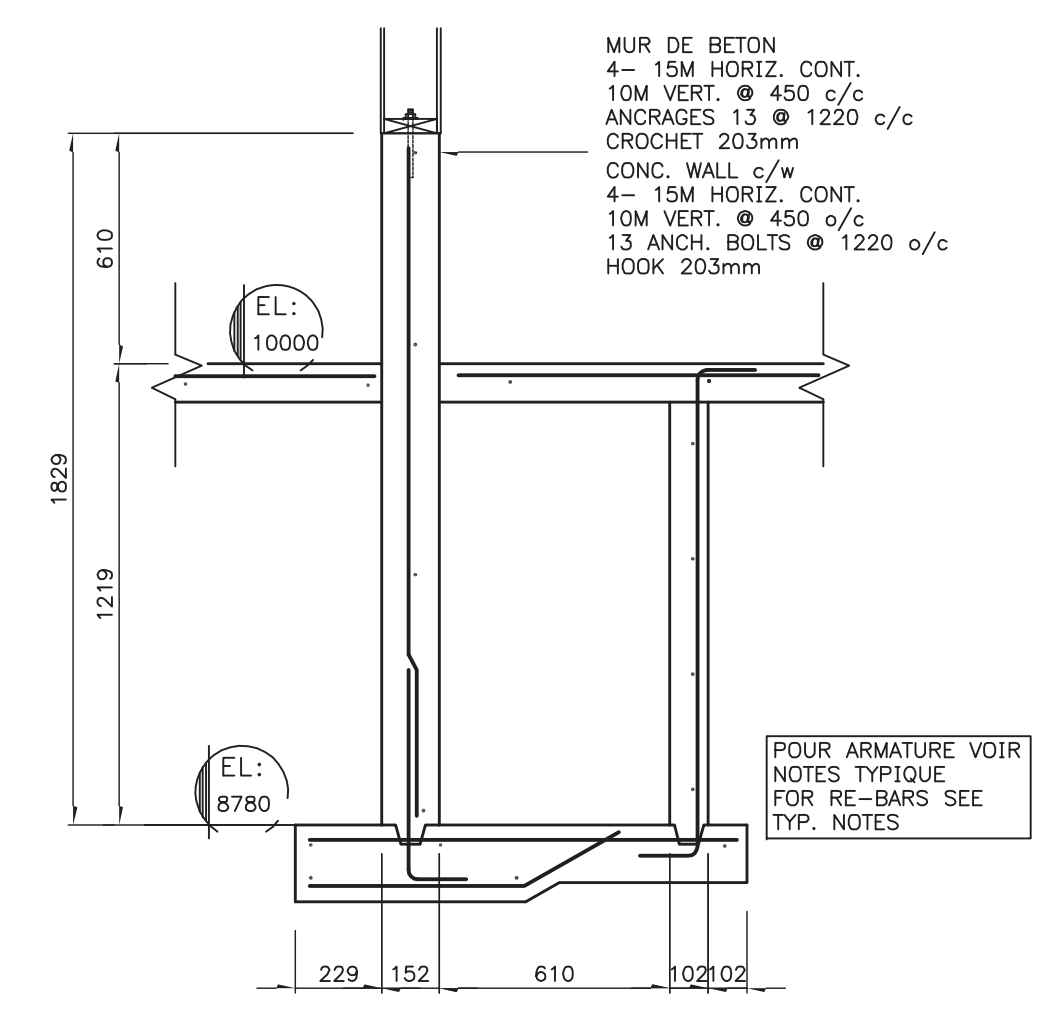
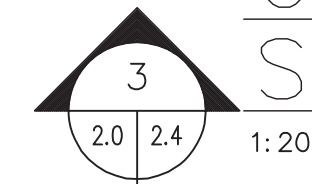

COUPE - BÂTIMENT (C)
SECTION - BUILDING (C)

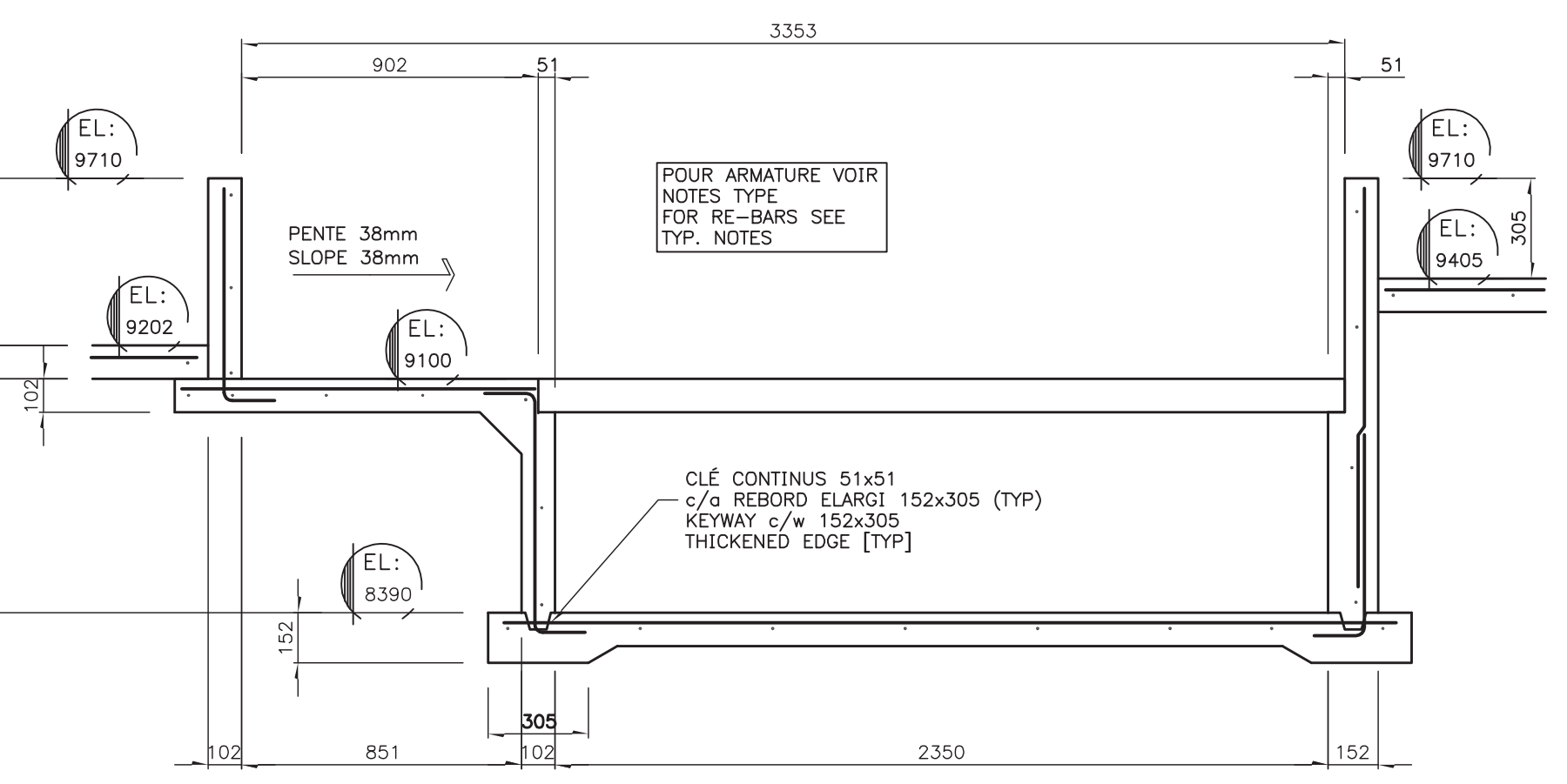
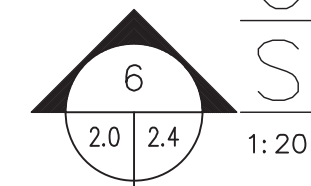

COUPE - BÂTIMENT (B)
SECTION - BUILDING (B)

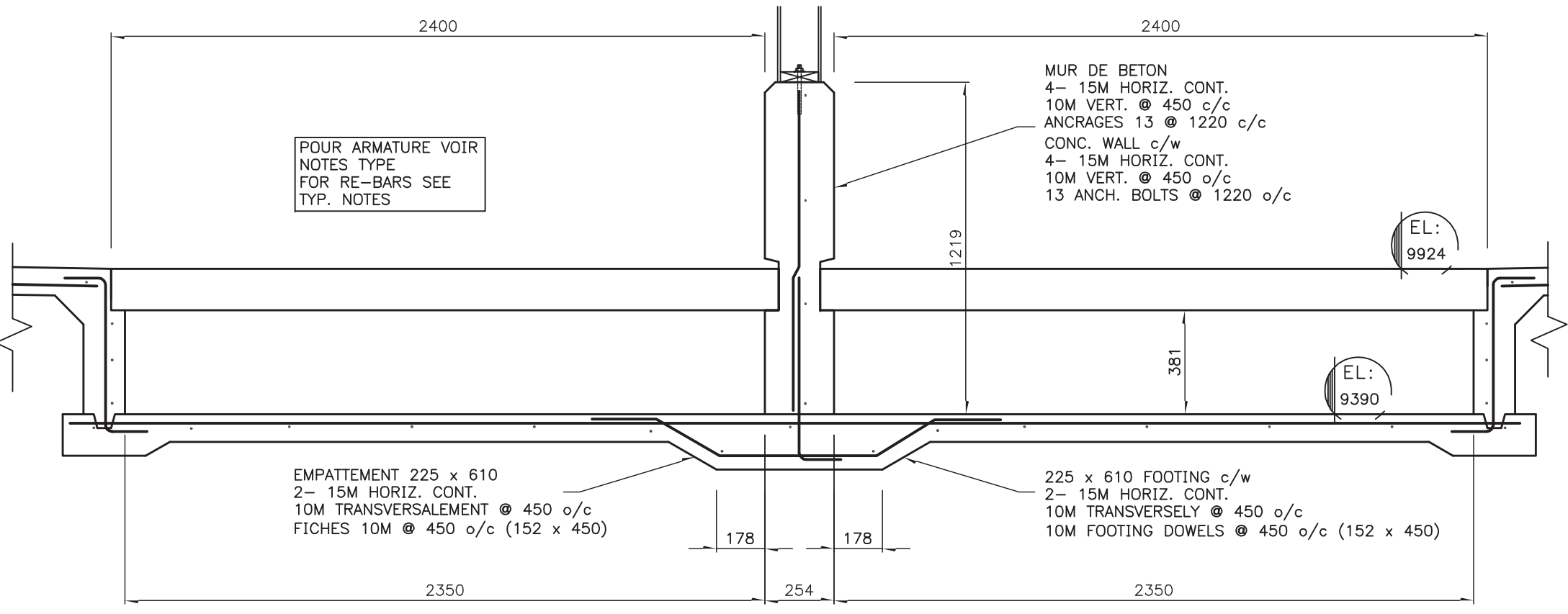
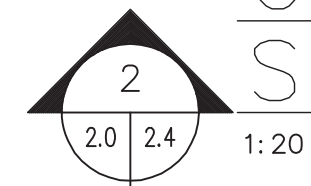

COUPE - BÂTIMENT (C)
SECTION - BUILDING (C)

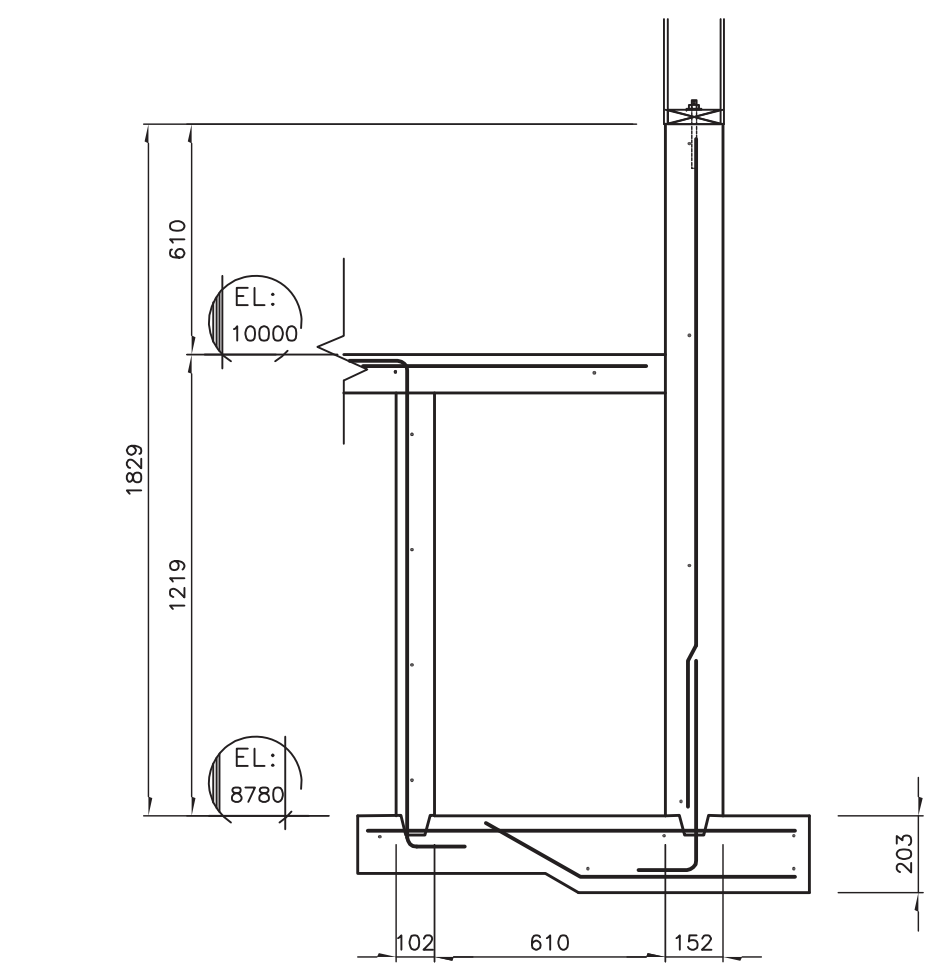
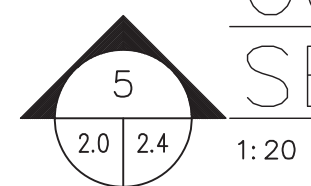

COUPE BÂTIMENT (C)
SECTION BUILDING (C)

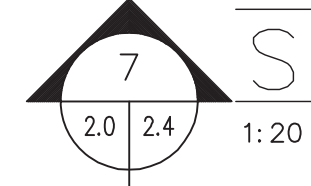

2	TEL QUE CONSTRUIT/ AS-BUILT	05/01/00
1	EMIS POUR CONST./CONSTR. ISSUE	01/04/98
0	POUR SOUMISSION/TENDER ISSUE	05/12/97

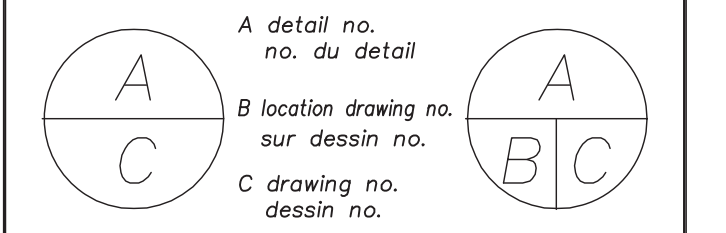

project **LENNOXVILLE** projet
CENTRE DE RECHERCHE ET DE DEVELOPPMENT
RESEARCH AND DEVELOPMENT CENTRE

COMPLEXE PORCIN
EXPERIMENTAL
EXPERIMENTAL PORCINE
COMPLEX

COUPE DES FONDATIONS
POUR LES BATIMENTS (A,B & C)
FOUNDATIONS SECTIONS
FOR BUILDINGS (A,B & C)

designed **DGH Engineering Ltd.** conceu
date **03/01/97**
drawn **D.G. Hodgkinson, P. Eng.** dessine

Tender **Yves Carol Jean, ing.** Soumission
PWC Project Manager Administrateur de projets IPC
drawing number **702642- 702643** no. du projet

drawing no. **QU-97153-B** no. de dessin
sheet no. **S-2.4** feuille no.

AutoCAD® A-1 702642- 702643\LRSS24.DWG

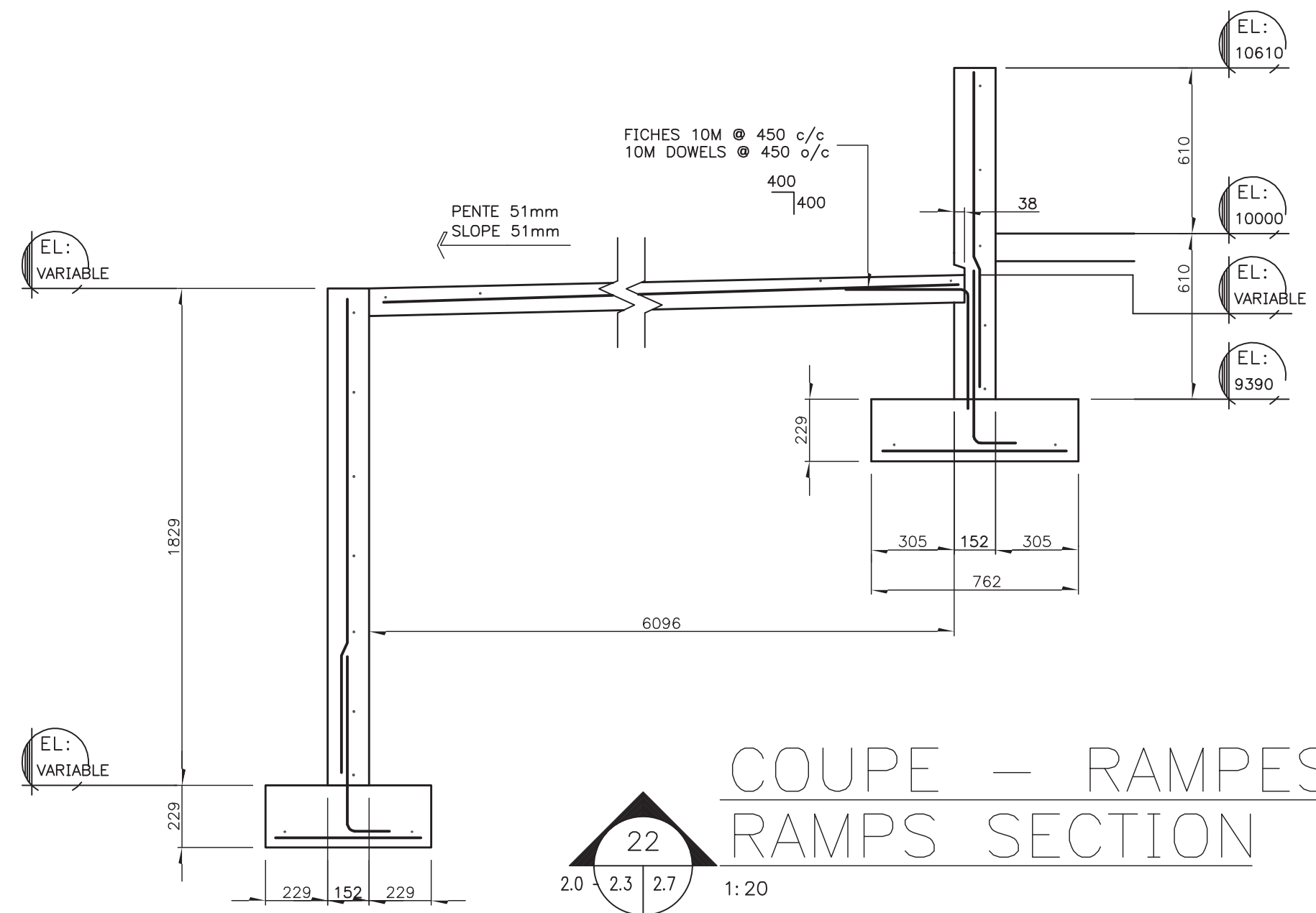

**FOUNDATION POUR L'ENCLOS CARRÉ AU MEUNERIE
FOUNDATION FOR SQUARE BINS AT FEED MILL**

1:50

**COUPE - RAMPES
RAMPS SECTION**

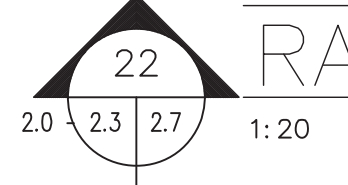

ARMATURE TYPE-TYP. RE-BARS

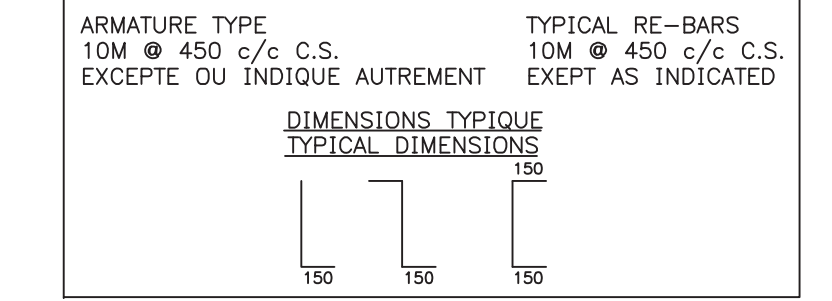

POUR TOUT LES MURS DE BÉTON, PREVOIR UNE CLÉ [38x38] ENTRE LE MUR ET LES FONDATIONS.
FOR ALL CONCRETE WALLS PROVIDE A KEY [38x38] BETWEEN THE WALL & THE FOUNDATIONS.

Pour la construction, les présents plans doivent absolument être consultés en parallèle avec les plans d'architecture. Vous y trouverez l'information requise pour déterminer les cotes, dimensions et niveaux de plancher. L'entrepreneur devra corriger ou reprendre à ses frais tout travail qui ne sera pas conforme à l'ensemble des plans.
For construction, these plans must absolutely be consulted in parallel with the architectural plans. You will find the required information to determine dimensions and floor levels. The Contractor will have to correct or re-do, at his own expense, all work which does not conform to all the drawings.

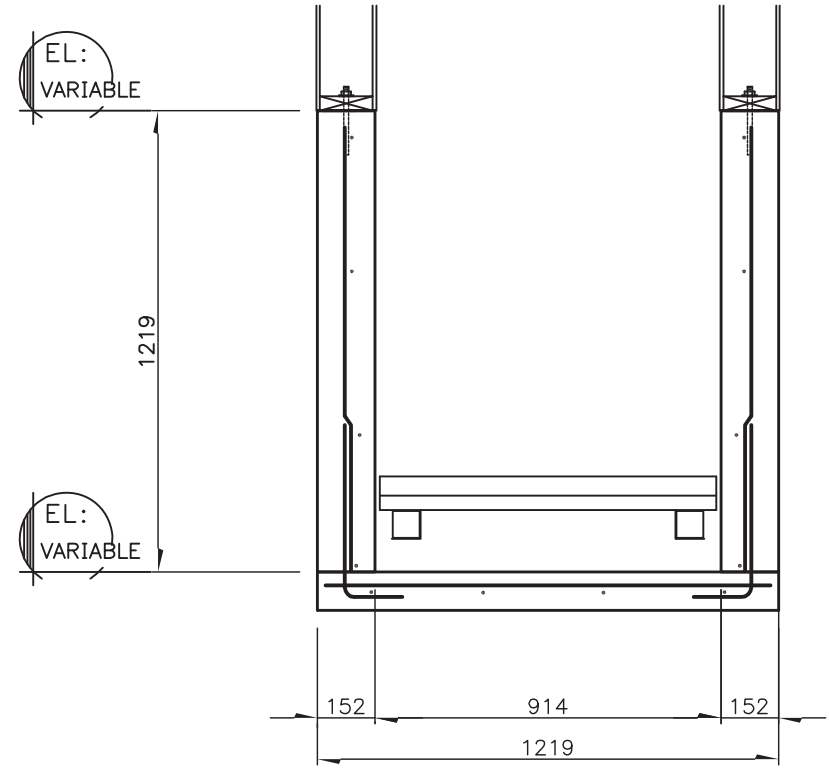

**COUPE - RAMPES
RAMPS SECTION**

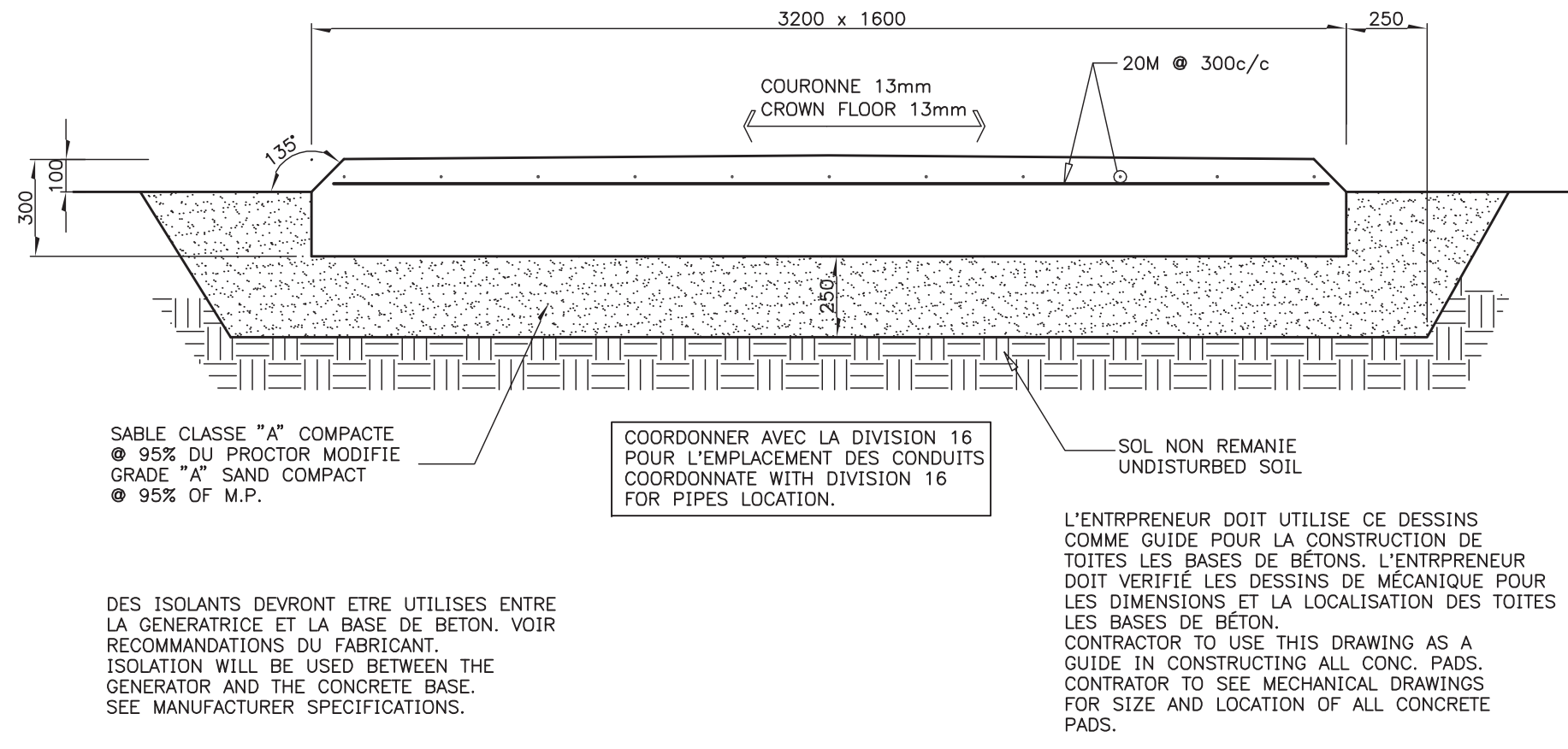
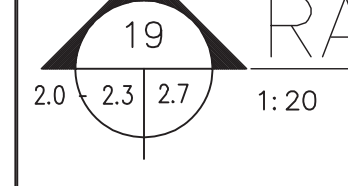

**BASE POUR GENERATEUR- [TYP]
GENERATOR BASE- [TYP]**

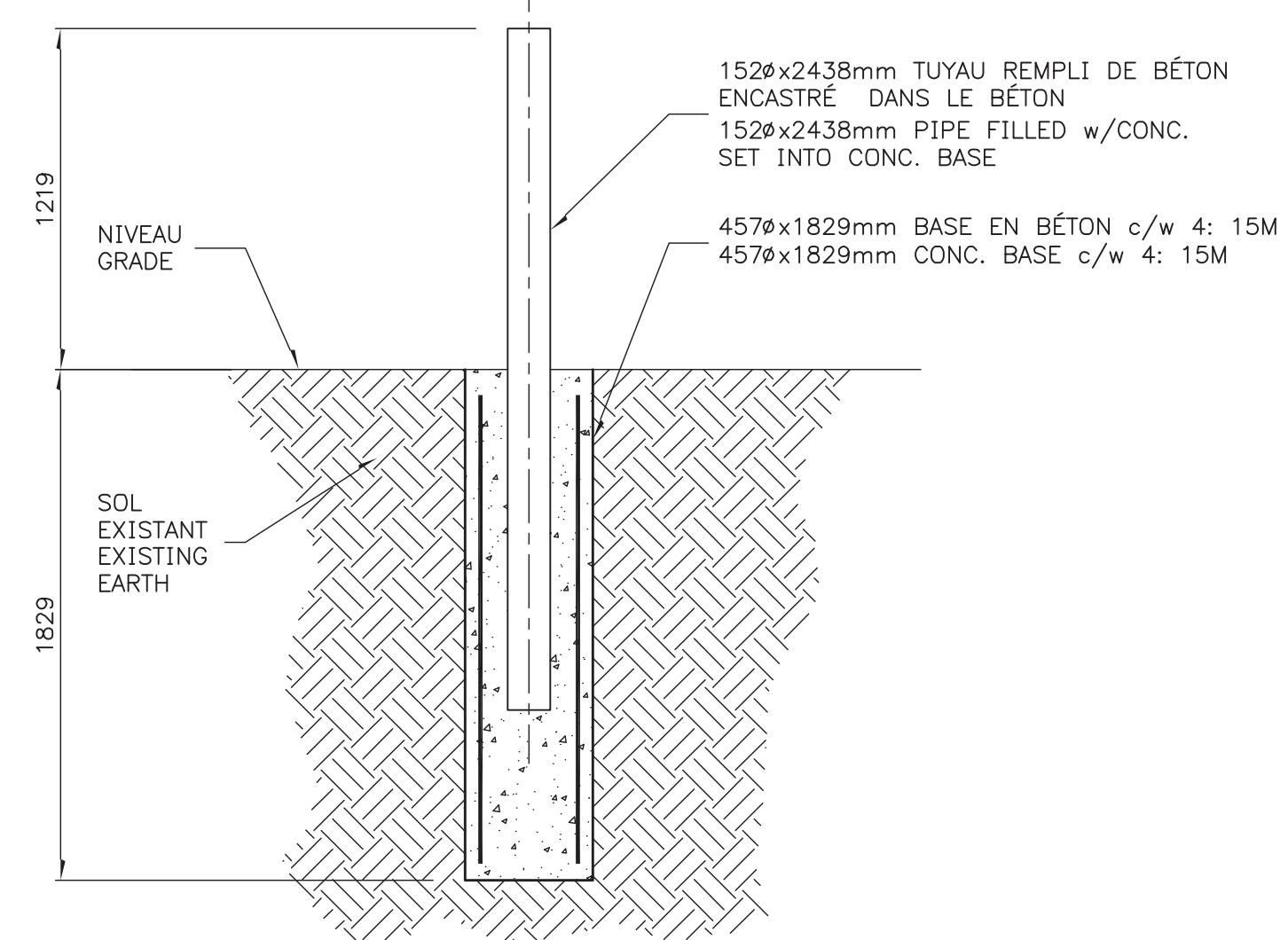

**DÉTAIL DE LA POSE DES POTEAUX
BOLLARD DETAIL- [TOTAL OF 7]**

1:25

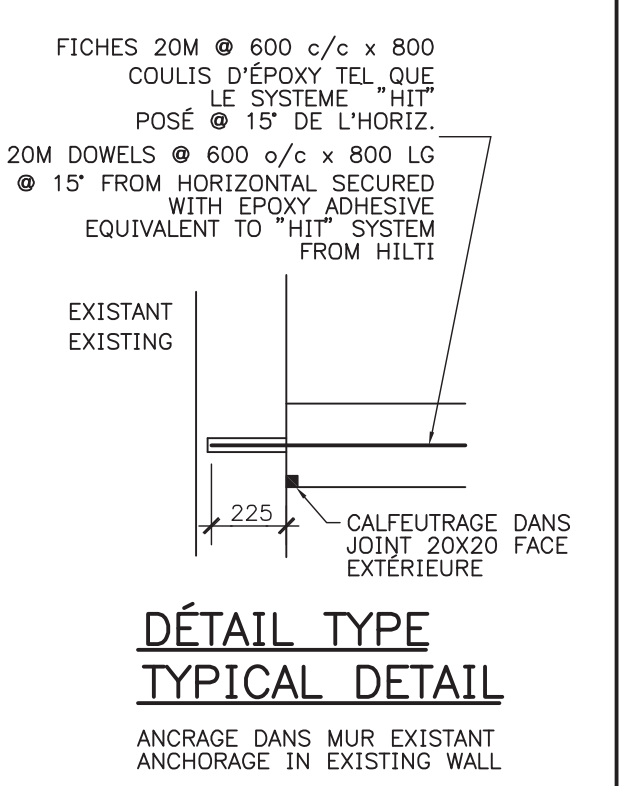

**DÉTAIL TYPE
TYPICAL DETAIL**

ANCRAGE DANS MUR EXISTANT
ANCHORAGE IN EXISTING WALL

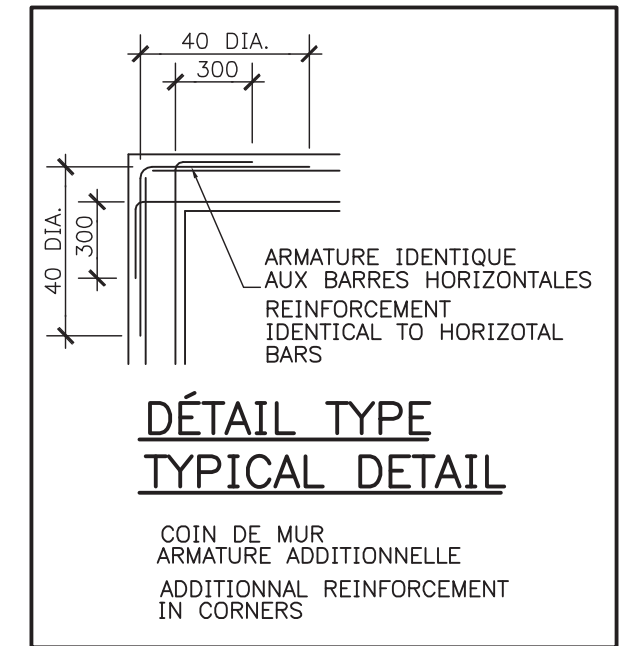

**DÉTAIL TYPE
TYPICAL DETAIL**

COIN DE MUR
ARMATURE ADDITIONNELLE
ADDITIONAL REINFORCEMENT
IN CORNERS

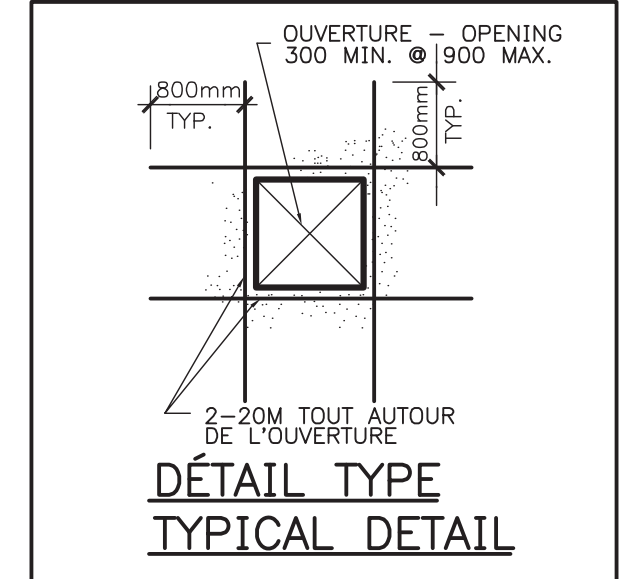

**DÉTAIL TYPE
TYPICAL DETAIL**

ARMATURE AUTOUR DES OUVERTURES
SAUF SI INDIQUÉ AUTREMENT
REINFORCEMENT AROUND OPENINGS
EXCEPT WHERE SHOWN OTHERWISE

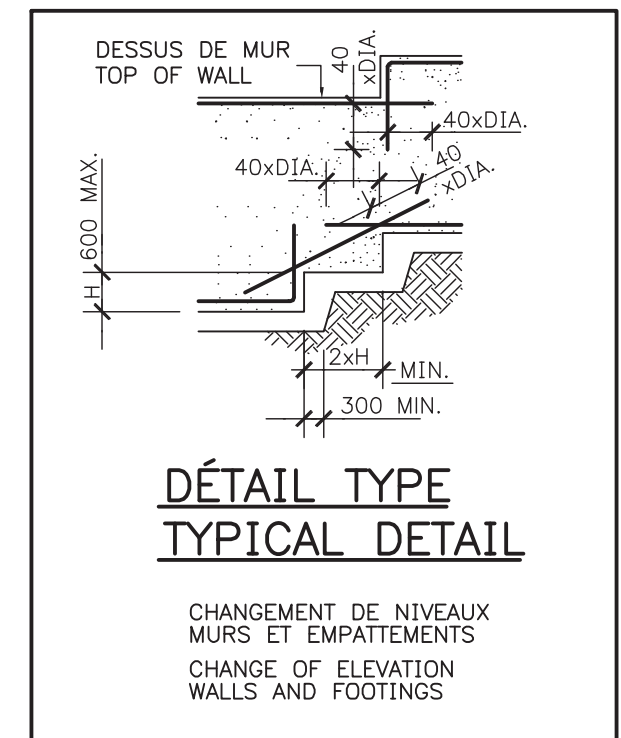

**DÉTAIL TYPE
TYPICAL DETAIL**

CHANGEMENT DE NIVEAUX
MURS ET EMPATTEMENTS
CHANGE OF ELEVATION
WALLS AND FOOTINGS

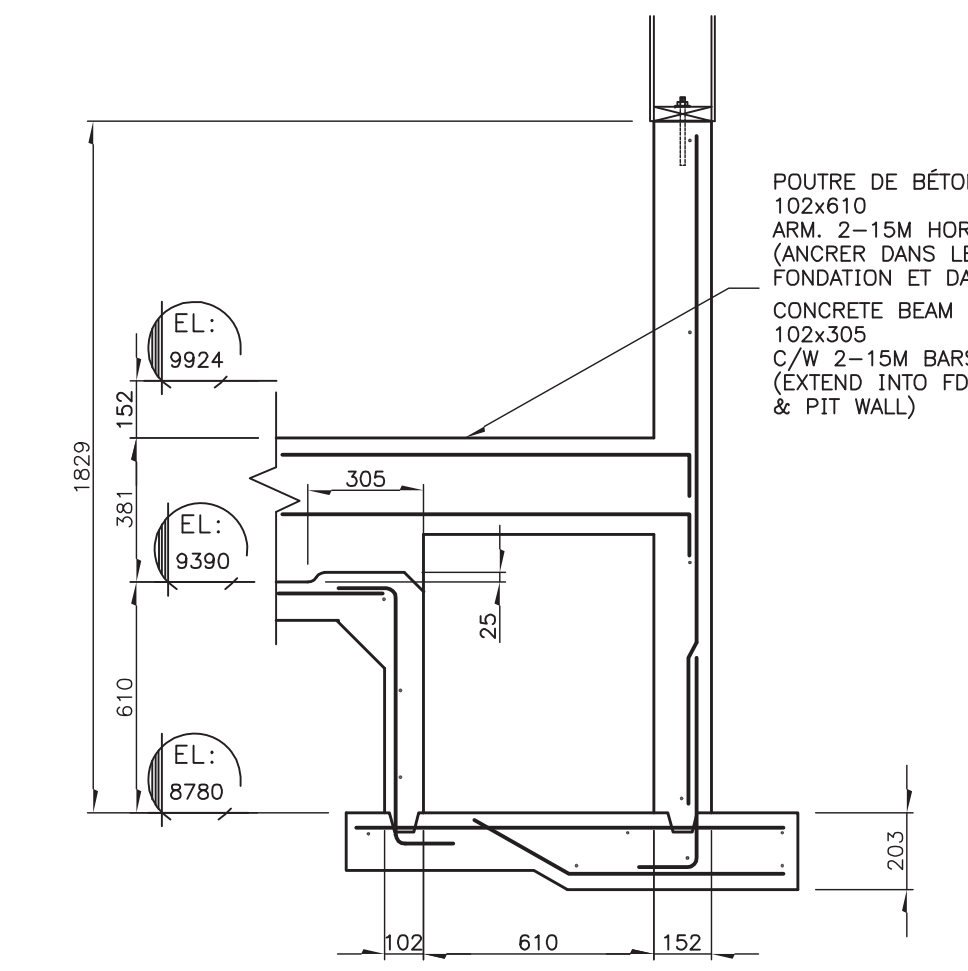

**COUPE - BÂTIMENT (C)
BUILDING (C) SECTION**

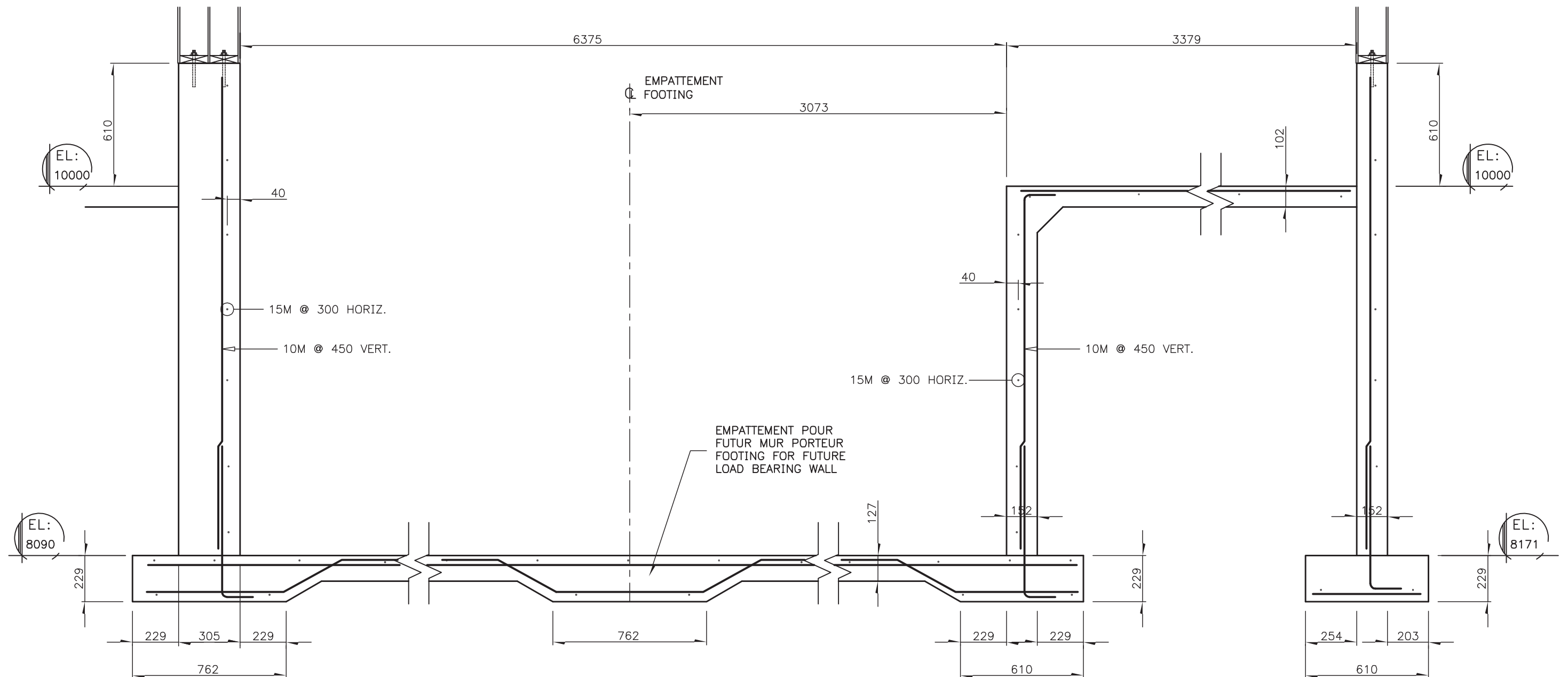
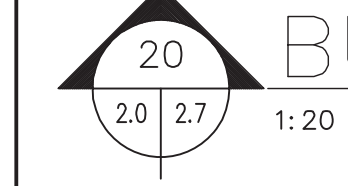

**COUPE - BÂTIMENT (E) - MEUNERIE
SECTION - BUILDING (E) - FEED MILL**

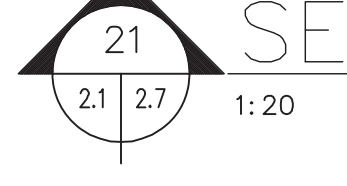

2	TEL QUE CONSTRUIT/ AS-BUILT	05/01/00
1	EMIS POUR CONST./CONST. ISSUE	01/04/98
0	POUR SOUMISSION/TENDER ISSUE	05/12/97

revisions	no. du detail	date
A	A detail no.	
B	B location drawing no.	
C	C drawing no.	

project **LENNOXVILLE** projet
CENTRE DE RECHERCHE ET DE DEVELOPPMENT
RESEARCH AND DEVELOPMENT CENTRE
**COMPLEXE PORCIN
EXPÉRIMENTAL**
EXPERIMENTAL PORCINE
COMPLEX

**DETAILS DES FONDATIONS
FOUNDATION DETAILS**

designed	conçu
DGH Engineering Ltd.	03/01/97
date	
drawn	dessiné
	03/01/97
date	
approved	approuvé
D.G. Hodgkinson, P. Eng.	
date	
Tender	Submission
Yves Carol Jean, ing.	Administrateur de projets IPC
PWC Project Manager	
drawing number	no. du projet
702642- 702643	
drawing no.	no. de dessin
sheet no.	feuille no.
QU-97153-B	S-2.7



Appendix "F"

INSURANCE TERMS



INSURANCE TERMS

IN1 GENERAL

- IN1.1 Worker's Compensation
- IN1.2 Indemnification
- IN1.3 Proof of Insurance
- IN1.4 Insured
- IN1.5 Payment of Deductible

IN2 COMMERCIAL GENERAL LIABILITY

- IN2.1 Scope of Policy
- IN2.2 Period of Insurance

IN3 AUTOMOBILE INSURANCE

- IN3.1 Scope of Policy

IN4 BUILDER'S RISK / INSTALLATION FLOATER

- IN4.1 Scope of Policy
- IN4.2 Amount of Insurance
- IN4.3 Period of Insurance
- IN4.4 Insurance Proceeds

IN1 GENERAL

IN1.1 Worker's Compensation

- 1) The Contractor shall provide and maintain Worker's Compensation Insurance in accordance with the legal requirements of the Province or Territory where the work is being carried out.

IN1.2 Indemnification

- 1) The insurance required by the provisions of these Insurance Terms shall in no way limit the Contractor's responsibility under the Indemnification clause of the General Conditions of the contract. Any additional coverage the Contractor may deem necessary to fulfill his obligations under the aforesaid clause shall be at his own discretion and expense.

IN1.3 Proof of Insurance

- 1) Before commencement of the Work, and within thirty (30) days after acceptance of its bid, the Contractor shall deposit with Canada a CERTIFICATE OF INSURANCE (form AAFC / AAC5314) available upon request.
- 2) In the event that the Contractor already possesses an insurance certificate clearly demonstrating that their insurance coverage meets IN2.1 Scope of Policy provisions, then the Contractor may deposit an original copy of this insurance certificate.
- 3) Upon request by Canada, the Contractor shall provide originals or certified true copies of all contracts of insurance maintained by the Contractor pursuant to the provisions contained herein.

IN1.4 Insured

- 1) Each policy shall insure the Contractor and shall include Her Majesty the Queen in right of Canada, represented by the Minister of Agriculture & Agri-Food Canada as an additional Insured, with respect to liability arising out of the operations of the contractor with regard to the work.

INSURANCE TERMS (Continued)

IN1.5 Payment of Deductible

- 1) The payment of monies up to the deductible amount made in satisfaction of a claim shall be borne by the Contractor.

IN2 COMMERCIAL GENERAL LIABILITY

IN2.1 Scope of Policy

- 1) The insurance coverage provided shall not be less than that provided by IBC Form 2100, as amended from time to time, and shall have:
 - (a) an Each Occurrence Limit of not less than \$1,000,000.00 ;
 - (b) a Products/Completed Operations Aggregate Limit of not less than \$1,000,000.00 ; and
 - (c) a General Aggregate Limit of not less than \$2,000,000.00 per policy year, if the policy is subject to such a limit.
- 2) The policy shall either include or be endorsed to include coverage for the following exposures or hazards if the Work is subject thereto:
 - (a) Blasting.
 - (b) Pile driving and caisson work.
 - (c) Underpinning.
 - (d) Removal or weakening of support of any building or land whether such support be natural or otherwise if the work is performed by the insured contractor.
 - (e) Asbestos.
 - (f) Non-owed Automobile Policy.

IN2.2 Period of Insurance

- 1) Unless otherwise directed in writing by Canada, or, otherwise stipulated elsewhere herein, the policy required herein shall be in force and be maintained from the date of contract award until the day of issue of the Certificate of Completion except that the coverage for Completed Operations Liability shall, in any event, be maintained for a period of at least six (6) years beyond the date of the CERTIFICATE OF COMPLETION.

IN3 AUTOMOBILE INSURANCE

IN3.1 Scope of Policy

- 1) Automobile Liability Insurance in respect of licensed vehicles shall have limits of not less than one million dollars inclusive per occurrence for bodily injury, death, and damage to property.

INSURANCE TERMS (Continued)

IN4 BUILDER'S RISK / INSTALLATION FLOATER

IN4.1 Scope of Policy

- 1) The insurance coverage provided by a Builder's Risk policy or an Installation Floater policy shall not be less than that provided by IBC Forms 4042 and 4047, as amended from time to time.
- 2) The policy shall permit use and occupancy of the project, or any part thereof, where such use and occupancy is for the purposes for which the project is intended upon completion.
- 3) The policy may exclude or be endorsed to exclude coverage for loss or damage caused by any of the following:
 - (a) Asbestos.
 - (b) Fungi or spores.
 - (c) Cyber.
 - (d) Terrorism.

IN4.2 Amount of Insurance

- 1) The amount of insurance shall not be less than the sum of the contract value plus the declared value (if any) set forth in the contract documents of all material and equipment supplied by Canada at the site of the project to be incorporated into and form part of the finished Work. If the value of the Work is changed, the policy shall be changed to reflect the revised contract value.

IN4.3 Period of Insurance

- 1) Unless otherwise directed in writing by Canada, or, stipulated elsewhere herein, the policy required herein shall be in force and be maintained from prior to the commencement of work until the day of issue of the CERTIFICATE OF COMPLETION.

IN4.4 Insurance Proceeds

- 1) The policy shall provide that the proceeds thereof are payable to Her Majesty or as Canada may direct in accordance with GC 9.3 Insurance Proceeds.
- 2) The Contractor shall, without delay, do such things and execute such documents as are necessary to effect payment of the proceeds.



Appendix "G"

FORM A - SUBCONTRACTING



FORM A –SUBCONTRACTING / SOUS-TRAITANCE

If there is to be no subcontracting, proposer must confirm it on this form and sign.

Si aucun sous-traitant ne sera utilisé, l'offrant doit le confirmer sur ce formulaire et le signer.

Contractor's list of subcontractors

It is my/our intention to employ the following subcontractors whom I/we believe, following investigation, to be reliable and competent for the performance of the portion of services being subcontracted. All other services will be performed by me/us.

Liste des sous-traitants de L'entrepreneur

J'ai (nous avons) l'intention de faire appel aux sous-traitants suivants qui, je crois (nous croyons), après avoir effectué une enquête, sont dignes de confiance et compétents pour l'exécution des travaux sous-traités. Je (nous) assurerai tous les autres services.

Nom de l'entreprise / Name of company	Services donnés en sous-traitance/ Services to be subcontracted	Nombre d'années en association avec ce sous-traitant/Number of years that you are associated with that subcontractor	Nombre d'années d'expérience du sous-traitant dans ce domaine/Years of experience of subcontractor in the field	Portion du contrat (%) / Portion of the contract (%)

Je m'engage (nous nous engageons) à ne pas confier d'autres services en sous-traitance à des personnes ou à des sociétés, à moins d'obtenir l'autorisation écrite du ministre de l'Agriculture

It is agreed that I (we) shall not subcontract with any other individual or organization or for any other work, without the consent of the Minister of Agriculture

Name

Position

Signature

Date