

# Annex "D" Reference Document



## Environmental Standards and Guidelines Document Ontario Waterways

July 2017





**Environmental Standards and Guidelines Document – Ontario Waterways  
Project # R.082719.007**

Prepared by

SLR Consulting (Canada) Ltd.

For:

Parks Canada Agency

July, 2017



## **ACKNOWLEDGEMENT**

This Environmental Standards and Guidelines Document was prepared by SLR Consulting (Canada) Ltd. (SLR) for Parks Canada Agency (PCA) under contract with Public Services and Procurement Canada (PSPC). SLR gratefully acknowledge the input and direction provided by PCA's Ontario Waterways Unit and the project management team at PSPC. SLR and PCA also gratefully acknowledge Van Osch Innovations Ltd. (VOI) for allowing the use of their "Erosion and Sediment Control" training participant's manual (2005) and other reference materials in the preparation of this document. Similarly, SLR acknowledges the many authors of the reference documents used in the preparation of this document.



## TABLE OF CONTENTS

ACKNOWLEDGEMENT.....	i
PART 1: INTRODUCTION TO THE ENVIRONMENTAL STANDARDS AND GUIDELINES DOCUMENT, CONTEXT AND APPLICATION	
1.0 INTRODUCTION.....	1
1.1 Scope of the ESG Document.....	1
1.2 Objectives of the ESG Document.....	3
2.0 ESG DOCUMENT ORGANIZATION .....	4
3.0 ONTARIO WATERWAYS AND CONSTRAINTS TO CONSTRUCTION.....	6
3.1 Project Delivery Challenges and Constraints to Construction.....	7
4.0 PCA'S PROJECT DELIVERY PROCESS .....	16
4.1 Contractors' Environmental Responsibilities in Project Delivery.....	16
4.1.1 Planning and Design.....	16
4.1.2 Construction Tendering.....	16
4.1.3 Pre-Construction and Submittals.....	18
4.1.4 Construction and Project Completion.....	18
4.2 PCA's Environmental Responsibilities in Project Delivery .....	20
4.2.1 Project Initiation and Concept Stages .....	20
4.2.2 Planning and Design.....	20
4.2.3 Construction Tendering.....	21
4.2.4 Pre-Construction and Submittals.....	21
4.2.5 Construction and Project Completion.....	21
4.2.5.1 PCA's Surveillance Monitoring.....	23
4.2.5.2 Non-Compliance Procedures .....	23
4.3 Other Players and their Responsibilities.....	24
5.0 Environmental Management Plans .....	25
5.1 Overall EMP Requirements.....	25
5.1.1 Purpose and Scope of the EMP .....	26
5.1.2 Project Overview.....	26
5.1.3 Construction Plan and Schedules .....	26
5.1.4 Roles and Responsibilities of the Environmental Management Team .....	27
5.1.5 Environmental Awareness, Training and Competency .....	27
5.1.6 General Communications and Record Keeping .....	28
5.1.7 Environmental Incident Reporting .....	28



5.1.8	Environmental Monitoring and Adaptive Management Summary .....	28
5.1.9	EMP Review and Revision.....	30
5.1.10	Component Plan Requirements .....	30
6.0	INTRODUCTION TO ENVIRONMENTAL STANDARDS AND GUIDELINES (PART 2) .	45
6.1	General Environmental Protection Procedures .....	46
6.1.1	In-water Timing Windows and General Fish Protection Measures .....	46
6.1.2	Ground Disturbance Timing Windows.....	47
6.1.3	Surface Water, Erosion and Sediment Management Principles .....	47
6.1.4	Site Controls and Operational Constraints .....	48
6.1.5	Materials Stockpiling and Storage.....	49
6.2	Environmental Standards and Guidelines .....	49
<b>PART 2: ENVIRONMENTAL STANDARDS AND GUIDELINES</b>		

**LIST OF TABLES**

<b>Table 1</b>	<b>PCA’s Assets in the Rideau Canal and Trent-Severn Waterway Corridor.....</b>	<b>7</b>
<b>Table 2</b>	<b>Relevant Federal and Provincial Legislation for Projects on Ontario Waterways .....</b>	<b>14</b>
<b>Table 3</b>	<b>EMP Component Plans and Key Requirements.....</b>	<b>33</b>
<b>Table 4</b>	<b>Environmental Standards and Guidelines and Associated EMP Component Plans.....</b>	<b>44</b>
<b>Table 5</b>	<b>Typical Project Works and Activities on Ontario Waterways.....</b>	<b>45</b>
<b>Table 6</b>	<b>Environmental Standards and Guidelines and Associated Project Works and Activities .....</b>	<b>50</b>

**LIST OF FIGURES**

<b>Figure 1</b>	<b>Trent-Severn Waterway and Rideau Canal .....</b>	<b>9</b>
<b>Figure 2</b>	<b>Rideau Canal .....</b>	<b>10</b>
<b>Figure 3</b>	<b>Trent-Severn Waterway.....</b>	<b>11</b>
<b>Figure 4</b>	<b>PCA’s Project Delivery Process Summary .....</b>	<b>17</b>

**APPENDICES**

<b>Appendix A</b>	<b>Glossary and Acronyms</b>
<b>Appendix B</b>	<b>Policy and Legislative Context for Projects on Ontario Waterways</b>
<b>Appendix C</b>	<b>Parks Canada Agency’s Environmental Impact Assessment Process</b>
<b>Appendix D</b>	<b>Typical Project Works and Activities on Ontario Waterways</b>



## **PART 1:**

# **INTRODUCTION TO THE ENVIRONMENTAL STANDARDS AND GUIDELINES DOCUMENT, CONTEXT AND APPLICATION**



## 1.0 INTRODUCTION

For more than a century, the Government of Canada, consistent with national and international commitments, has been involved in protecting and presenting places that represent the world's natural and cultural heritage. In support of this effort, Parks Canada Agency (PCA) plays a leading role in federal government activities related to recognizing places representative of Canada's natural heritage and places of national historic importance, and in protecting and presenting these places to the public. PCA is also responsible for erecting and maintaining a variety of heritage markers. As such, it operates within broad, changing and varied contexts. National parks, marine conservation areas, historic canals and sites are PCA's key assets to achieve its mission.

PCA owns, operates, maintains and repairs numerous water and land-based assets on the Trent-Severn Waterway and the Rideau Canal. Water-based assets include: breakwaters, dams, locks, marine walls, water retaining structures, wharves and docks. Land-based assets include: pedestrian and vehicular bridges, operations and public use building and parking areas, monuments and plaques, day-use grounds, and various access and service roads.

These assets are operated to ensure long-term commemorative integrity and navigation requirements while meeting a broad range of stakeholder needs including: tourism and recreation, water management (e.g., flood mitigation), municipal water supply, hydro power generation and environmental management.

To assist PCA in managing its assets, PCA has developed this Environmental Standards and Guidelines (ESG) document. The document provides clear and practical guidance and sets PCA's expectations regarding minimum standards to mitigate potential environmental effects during construction, maintenance and repair projects on Ontario Waterways. It is PCA's intent to avoid and reduce the potential for adverse environmental effects, manage costs and liabilities, and meet regulatory and public expectations regarding sustainable development. Being responsible for protecting and presenting nationally significant examples of Canada's natural and cultural heritage, PCA is held to the highest of standards.

This ESG Document will be useful to PCA staff, its agents and Contractors involved in various types of projects on Ontario Waterways. This document may also be used for those third party (non-PCA) projects such as those proposed by hydroelectric power generation proponents and private landowners.

### 1.1 Scope of the ESG Document

PCA undertakes, approves and/or oversees a wide variety of projects on Ontario Waterways. This document focuses on providing clear and practical guidance and setting PCA's expectations regarding avoidance or reduction of adverse environmental effects during a variety of undertakings including the following construction, maintenance and repair projects:

- Lock repairs and upgrades;
- Bridge repairs, upgrades and replacement;
- Earth dam repairs and upgrades;
- Retaining and approach wall repairs and replacements;
- Concrete dam repairs and upgrades;



- Concrete dam replacement (in-situ);
- Concrete dam replacement (rebuilds downstream or upstream); and
- Gravel roads.

The ESG Document may also provide guidance for other works and activities on Ontario Waterways.

Where relevant, the scope of this document provides information for the following works and activities:

<b>Pre-Construction Works and Activities</b>	<b>Construction Works and Activities</b>	<b>Post-Construction Works and Activities</b>
<ul style="list-style-type: none"> <li>• Erosion Control</li> <li>• Sediment Control</li> <li>• Soil Stripping, Grubbing and Stockpiling</li> <li>• Tree Protection and Hording</li> <li>• Vegetation Clearing and Protection</li> </ul>	<ul style="list-style-type: none"> <li>• Abrasive Blasting</li> <li>• Blasting</li> <li>• Borehole and Rock Drilling</li> <li>• Chipping and Cutting</li> <li>• Concrete Pour Operations and Grouting</li> <li>• Dredging and Sediment Removal</li> <li>• Fish Exclusion, Salvage and Relocation</li> <li>• Fugitive Dust Control During Construction</li> <li>• Grinding and Welding</li> <li>• Installation and Removal of Cofferdams and Isolation Structure</li> <li>• Invasive Species Management</li> <li>• Pile Driving</li> <li>• Refueling and Spill Management</li> <li>• Treatment of Discharge Waters</li> <li>• Use and Maintenance of Heavy Equipment</li> <li>• Vehicle and Equipment Washing and Cleaning</li> <li>• Wildlife and Species at Risk Protection During Construction</li> <li>• Winter Weather Stabilization and Operations</li> </ul>	<ul style="list-style-type: none"> <li>• Revegetation</li> </ul>





## 1.2 Objectives of the ESG Document

In general, this ESG Document is intended to be used by PCA staff after the completion of an environmental impact assessment (EIA) but prior to the commencement of construction in developing contract specifications. It is intended to be used by Contractors in developing Environmental Management Plans (EMPs).

The specific objectives of this ESG Document are to:

- ✓ Establish PCA's Ontario Waterways Unit's Environmental Standards and Guidelines applicable to key works and activities undertaken as part of construction, maintenance and repair projects on Ontario Waterways;
- ✓ Encourage and facilitate consistency in the application of the environmental standards and guidelines across all projects undertaken on Ontario Waterways, and in the interpretation of key terms, concepts and requirements;
- ✓ Direct users of the ESG Document to other guidance documents, legislation or regulations where more specific information can be found;
- ✓ Identify the roles and responsibilities of PCA staff, its agents, Contractors and others potentially involved in the delivery of projects on Ontario Waterways;
- ✓ Describe PCA's environmental procedures and provide clear compliance processes;
- ✓ Offer a common and widely accepted reference point regarding the current legislative, regulatory and policy context that guides projects on Ontario Waterways; and
- ✓ Foster continuous improvement and learning.

While this ESG Document presents a broad set of standards and guidelines applicable to many projects undertaken on Ontario Waterways, it is not intended to:

- ✗ Address or provide guidance regarding the specific design or engineering aspects of project development;
- ✗ Address or provide guidance regarding issues related to the protection of historical, heritage or cultural resources;
- ✗ Replace information contained in other PCA guidance documents or external guidance materials;
- ✗ Remove discretion to adapt requirements for any specific project as information requirements will depend on the waterway, project type, environmental setting, etc. Discretion to adapt requirements for any specific project is essential and should be discussed with PCA;
- ✗ Serve as the definitive source for determining whether regulatory compliance will be, or has been, achieved for any particular project; or
- ✗ Impede or limit the possibility of using more site-specific, relevant or more up-to-date best practices, standards, guidelines or performance criteria.



## 2.0 ESG DOCUMENT ORGANIZATION

This ESG Document has been organized in two (2) parts with supporting appendices aimed at providing users with easy reference to key information. Throughout the document, “hot links” are provided to specific Standards and Guidelines via their unique *Identification Number*. This is intended to provide linkages between sections, linkages between standards and guidelines that are related and to improve navigation of the document.

### Part 1: Introduction to the ESG Document, Context and Application

Section	Content
Section 1: Introduction	Provides a general introduction to the ESG Document and the general context for its development and application. It describes the scope and objectives of the ESG Document, including what the document is intended for and what it is not intended for.
Section 2: ESG Document Organization (this section).	Provides an overview of each section of the ESG Document.
Section 3: Ontario Waterways and Constraints to Construction	Provides background information regarding the environmental and socio-economic setting of the Trent-Severn Waterway and Rideau Canal and identifies the key constraints to project delivery and construction in these settings.
Section 4: PCA’s Project Delivery Process	Describes the key stages in the delivery of projects by PCA and the roles and environmental responsibilities of Contractors, PCA and others throughout this process.
Section 5: Environmental Management Plans	Describes the purpose and intent of Environmental Management Plans (EMP) in project delivery. It sets out PCA’s expectations regarding the overall structure and content requirements for EMPs, including general EMP requirements and those of its component plans.
Section 6: Introduction to Environmental Standards and Guidelines (Part 2)	Describes the typical projects undertaken by PCA on Ontario Waterways, including the identification of typical works and activities. It provides a general introduction to the information presented in Part 2 of this ESG Document.



## Part 2: Environmental Standards and Guidelines

Category	Environmental Standards and Guidelines	Identifier
Pre- Construction Works and Activities	Erosion Control	ESG-1-Pre
	Sediment Control	ESG-2-Pre
	Soil Stripping, Grubbing and Stockpiling	ESG-3-Pre
	Tree Protection and Hording	ESG-4-Pre
	Vegetation Clearing and Protection	ESG-5-Pre
Construction Works and Activities	Abrasive Blasting	ESG-1-C
	Blasting	ESG-2-C
	Borehole and Rock Drilling	ESG-3-C
	Chipping and Cutting	ESG-4-C
	Concrete Pour Operations and Grouting	ESG-5-C
	Dredging and Sediment Removal	ESG-6-C
	Fish Exclusion, Salvage and Relocation	ESG-7-C
	Fugitive Dust Control During Construction	ESG-8-C
	Grinding and Welding	ESG-9-C
	Installation and Removal of Cofferdams and Isolation Structure	ESG-10-C
	Invasive Species Management	ESG-11-C
	Pile Driving	ESG-12-C
	Refueling and Spill Management	ESG-13-C
	Treatment of Discharge Waters	ESG-14-C
	Use and Maintenance of Heavy Equipment	ESG-15-C
	Vehicle and Equipment Washing and Cleaning	ESG-16-C
	Wildlife and Species at Risk Protection During Construction	ESG-17-C
	Winter Weather Stabilization and Operations	ESG-18-C
Post-Construction Works and Activities	Revegetation	ESG-1-Post

## Appendices

Appendix	Content
<u>Appendix A</u> : Glossary and Acronyms	Defines key terms and acronyms used throughout the ESG Document.
<u>Appendix B</u> : Policy and Legislative Context for Projects on Ontario Waterways	Provides a description of PCA policies and the federal and provincial legislation and regulations relevant to Projects on Ontario Waterways
<u>Appendix C</u> : Parks Canada Agency's Environmental Impact Assessment (EIA) Process	Describes the overall Environmental Impact Assessment process used by PCA in delivering projects on Ontario Waterways.
<u>Appendix D</u> : Typical Project Works and Activities	Describes the works and activities that are typically undertaken during project development.



### **3.0 ONTARIO WATERWAYS AND CONSTRAINTS TO CONSTRUCTION**

In 2012, PCA management of the Rideau Canal and the Trent-Severn Waterway was consolidated into one group, now referred to as “Ontario Waterways” within PCA. The Ontario Waterways’ unit managing the Rideau Canal is headquartered in Smiths Falls, Ontario; and the unit managing the Trent-Severn Waterway is headquartered in Peterborough, Ontario. Figure 1 shows the locations of both these historic canals and the locations of PCA’s Ontario Waterways unit headquarters.

PCA manages its assets on the Rideau Canal and the Trent-Severn Waterway in accordance with their respective management plans. The most recent management plan for the Rideau Canada National Historic Site received ministerial approvals in 2005 and the management plan for the Trent-Severn Waterway National Historic Site of Canada received ministerial approval in 2000.

As shown on Figure 2, the Rideau Canal corridor extends 202 km from the City of Ottawa in the northeast to the City of Kingston in the southwest and is comprised of a chain of lakes, rivers and 19 km of constructed canals. Access to the Canal is possible at all of the Canal’s lock stations and by way of marinas, resorts, public boat launches, parks and conservation areas. The Tay Canal, which provides a navigation route between Lower Rideau Lake and the Town of Perth by way of Beveridges Lockstation, also connects to the Rideau Canal.

As shown on Figure 3, The Trent-Severn Waterway is a 386 km inland corridor of lakes and rivers in southern Ontario permitting continuous navigation from Lake Ontario in the south to Georgian Bay in the north. The Waterway follows the course of the Trent, Otonabee and Severn Rivers, which now connect a complex system of lakes, linked by artificial and improved river channels with levels controlled by dams and navigation locks. The drainage basins of the Trent and Severn Rivers cover approximately 18,600 km<sup>2</sup>. The Murray Canal, which is an 8 km canal connecting the Bay of Quinte to Lake Ontario on the Trent-Severn Waterway is also managed by PCA.

PCA owns, operates, maintains and repairs numerous water-based and land-based assets in both canal corridors that are summarized in the following table.



**Table 1: PCA's Assets in the Rideau Canal and Trent-Severn Waterway Corridor**

<b>Water Based Assets</b>	<b>Type of Asset</b>	<b>Rideau Canal Assets (#)</b>	<b>TSW Assets (#)</b>
	Breakwaters	16	27
	Dams	105	176
	Locks	47	44
	Approach Walls	86	124
	Water Retaining Structures	2	11
	Wharves, Docks and Boat Launches	53	15
	Other Structures	20	13
<b>Land Based Assets</b>	<b>Type of Asset</b>	<b>Rideau Canal Assets (#)</b>	<b>TSW Assets (#)</b>
	Pedestrian Bridges	3	4
	Vehicular Bridges	27	38
	Operation, Administration and Utility Buildings	47	100
	Public Use Buildings	49	48
	Staff Housing	20	5
	Day-Use Grounds / Trails	43	54
	Monuments and Plaques	53	23
	Heritage Structures	4	4
	Parking Areas	29	43
	Other Grounds	10	31
	Access Roads to Visitor Facilities / Service Roads	4	18

### **3.1 Project Delivery Challenges and Constraints to Construction**

The following describes some of the key challenges that PCA and Contractors face in delivering projects and constraints faced in undertaking major construction projects in the Rideau Canal and Trent-Severn Waterways corridors.

#### ***Construction in Water and/or Near Water***

Construction projects within the corridors are often undertaken on small parcel(s) of federally owned terrestrial land and waterways which contain multiple assets or large aquatic parcels covering larger system. Although the aquatic parcels are quite large, construction will only occur on small portions at one time. In addition, what happens at a project site can have implications both upstream and downstream. Contractors will need to plan their activities carefully to minimize their construction site's footprint and encroachment and/or damage of nearby assets on-site, upstream and downstream. Most importantly, any project on Ontario Waterways will be undertaken in water and/or near water. Project works and activities will need to be undertaken to the highest standards to maintain adequate flows and protect riparian



habitat and water quality. In some instances, new or unique technologies might need to be employed to avoid and minimize potentially adverse effects to water quality and aquatic life.

### ***Protection of Historic Sites***

The Rideau Canal is the oldest continuously operated canal in North America. The Canal was first commemorated as a National Historic Site in 1926 and designated as a UNESCO World Heritage Site in 2007. The Trent-Severn Waterway is considered one of the most important National Historic Sites in Canada. Its many unmodified canal structures, particularly in the Lake Simcoe-Balsam Lake section of the Waterway, dating from the construction era of 1900-1907, are specified as being nationally significant.

National Historic Sites, by their very nature, are irreplaceable. Construction projects will need to be undertaken in a manner that avoids damage to these assets and maintains their commemorative integrity.

N:\Markham\GIS\Projects\_GIS209\_40404\_Trent\_Rideau\1.MXD\209\_40404\_RideauTrent\_SOnt.mxd

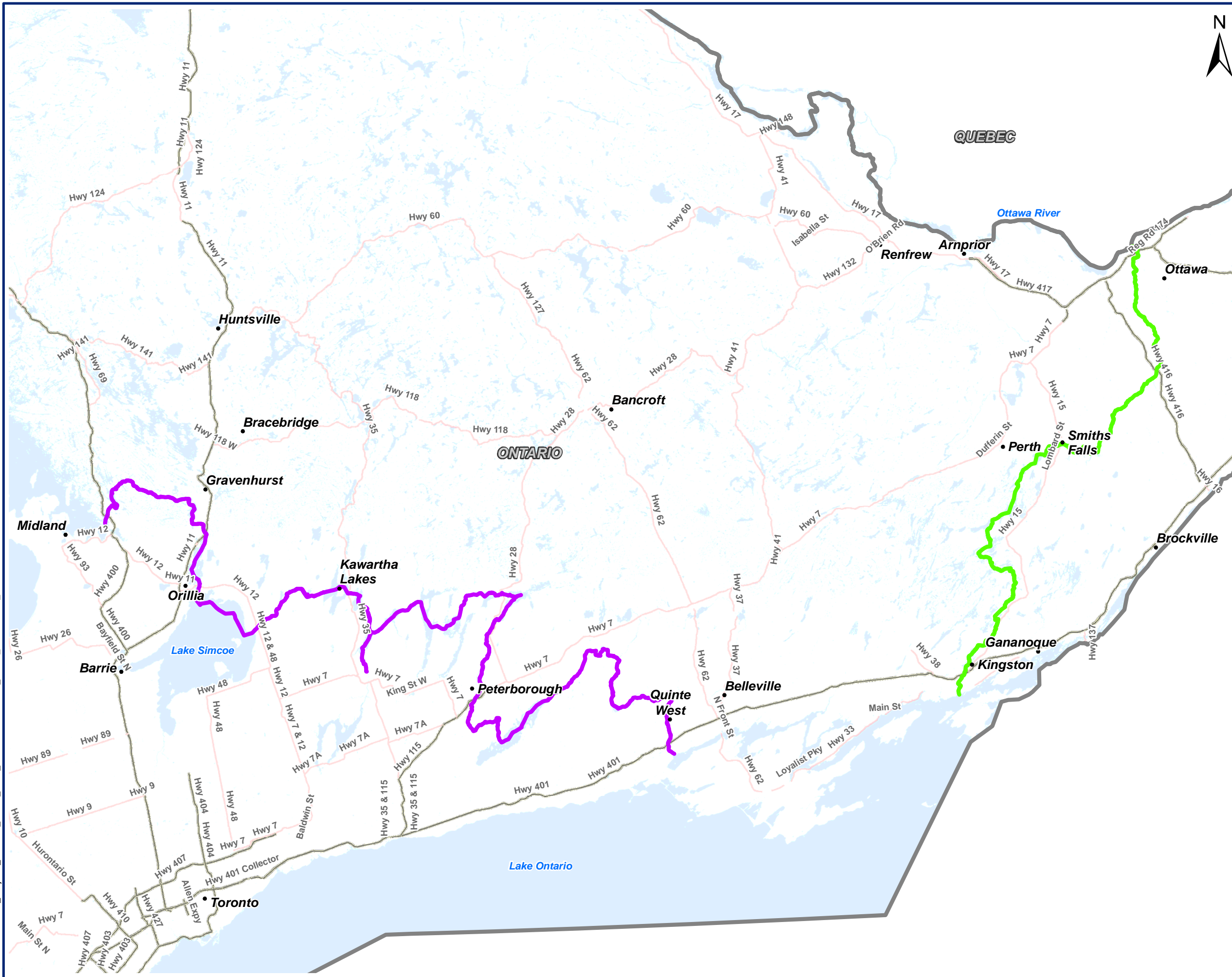

- LEGEND**
- Trent-Severn Waterway
  - Rideau Canal
  - Waterbodies

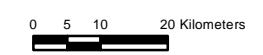

SCALE: 1:1,125,000  
 WHEN PLOTTED CORRECTLY AT 11 x 17  
 NAD 1983 UTM Zone 17N

**NOTES**  
 This map is for conceptual purposes only and should not be used for navigational purposes.  
 Basedata:

**PARKS CANADA  
 AGENCY**

**ENVIRONMENTAL STANDARDS  
 AND GUIDELINES DOCUMENT**

**TRENT-SEVERN WATERWAY  
 AND RIDEAU CANAL**

June 30, 2017	Rev <b>0.0</b>	Figure No.
Project No. 209.40404.00000		<b>1</b>



N:\Markham\GIS\Projects\_GIS\209\_40404\_Trent\_Rideau\1.MXD\209\_40404\_RideauCanal.mxd

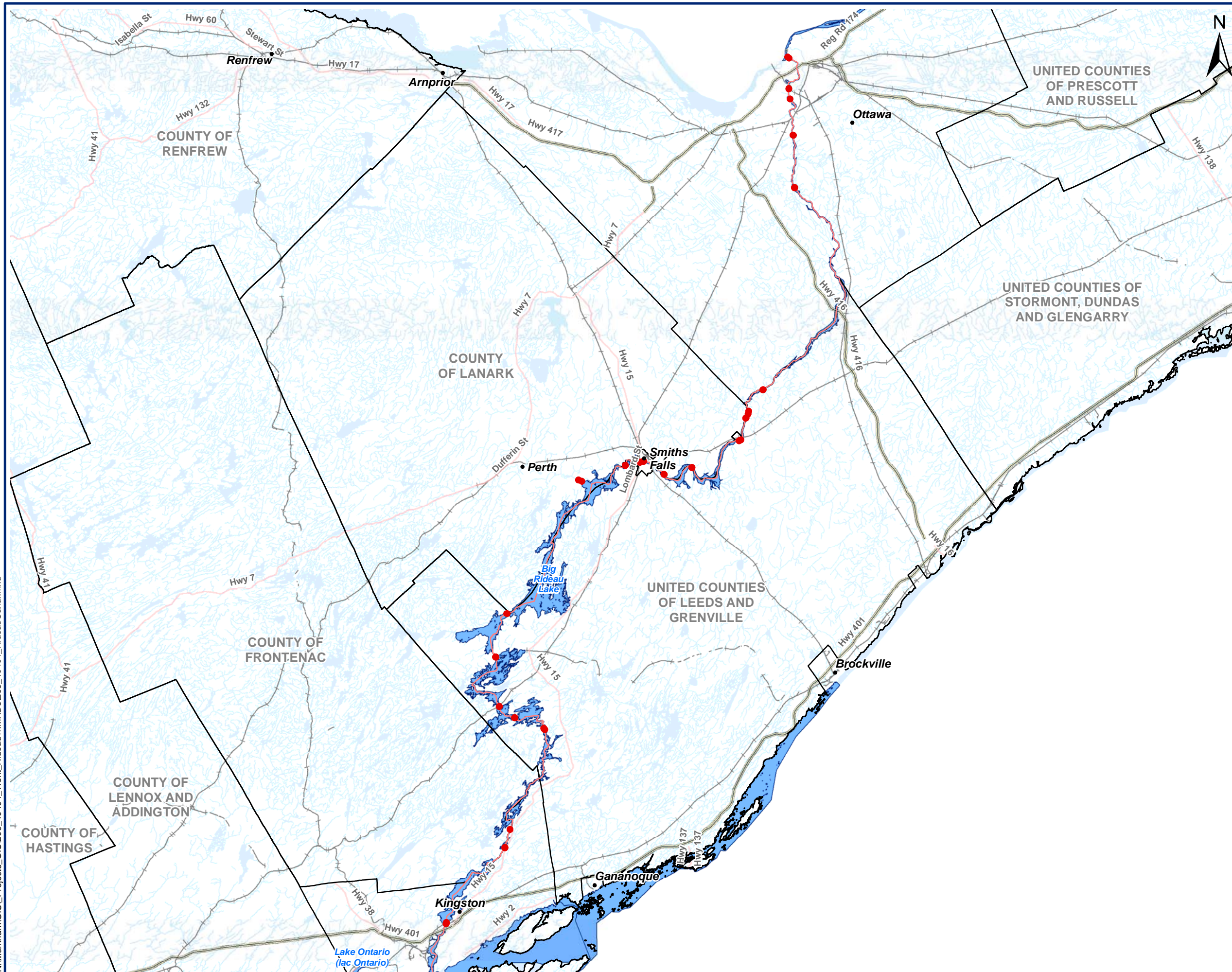

**LEGEND**

- Lock Locations
- Rideau Canal
- Municipalities
- Waterbodies in Canal System
- Watercourse
- Waterbodies



SCALE: 1:550,000  
WHEN PLOTTED CORRECTLY AT 11 x 17  
NAD 1983 UTM Zone 17N

**NOTES**

This map is for conceptual purposes only and should not be used for navigational purposes.

Basedata:

**PARKS CANADA  
AGENCY**

**ENVIRONMENTAL STANDARDS  
AND GUIDELINES DOCUMENT**

**RIDEAU CANAL**

June 30, 2017	Rev <b>0.0</b>	Figure No.
Project No. 209.40404.00000		<b>2</b>





N:\Markham\GIS\Projects\_GIS209\_40404\_Trent-SevernCanal.mxd

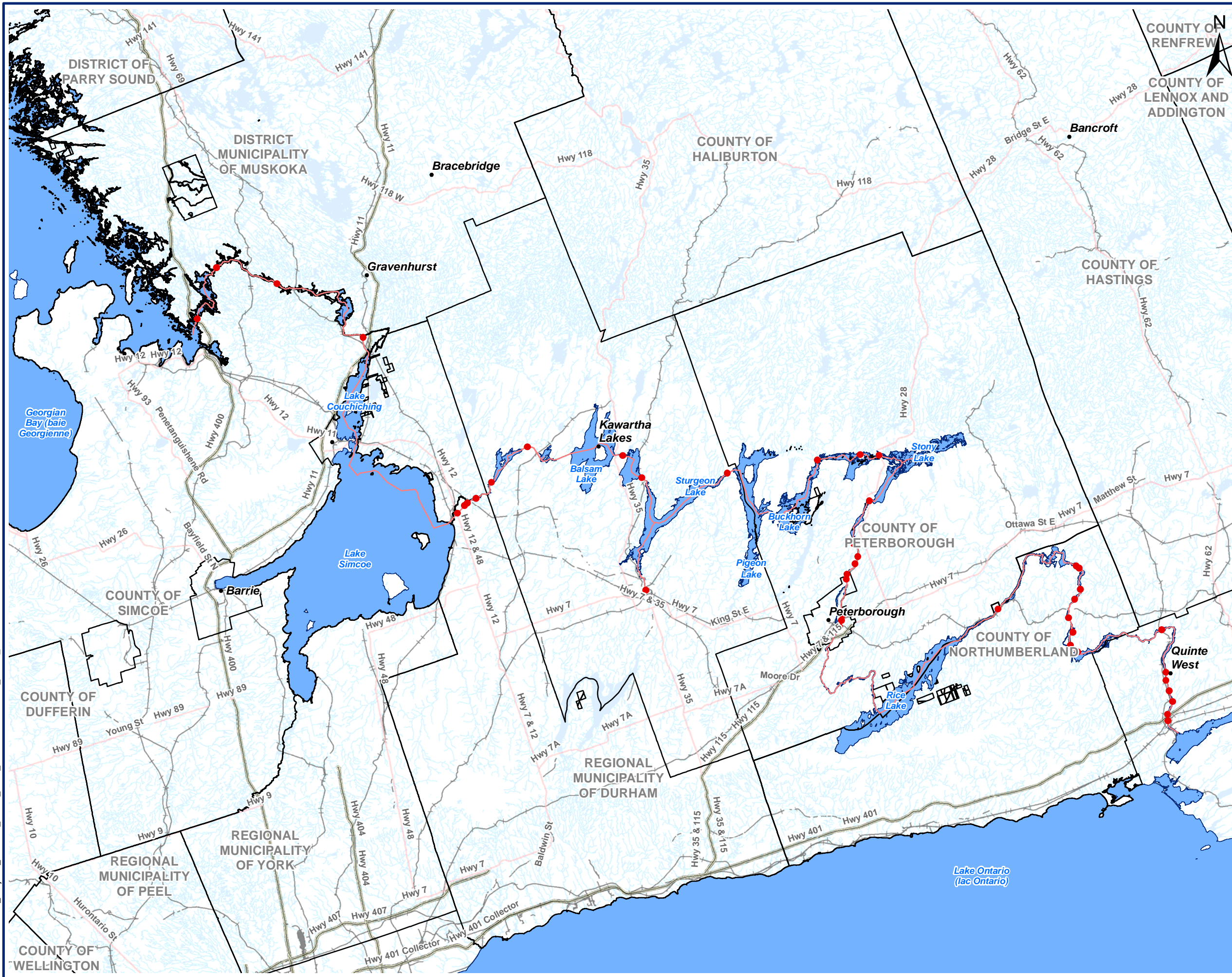

**LEGEND**

- Lock Locations
- Trent-Severn Waterway
- Municipalities
- Waterbodies in Waterway System
- Watercourse
- Waterbodies

**NOTES**  
 This map is for conceptual purposes only and should not be used for navigational purposes.  
 Basedata:

COUNTY OF RENFREW  
 COUNTY OF LENNOX AND ADDINGTON  
 COUNTY OF HALIBURTON  
 COUNTY OF HASTINGS  
 COUNTY OF PETERBOROUGH  
 COUNTY OF NORTHUMBERLAND  
 COUNTY OF DUFFERIN  
 COUNTY OF SIMCOE  
 REGIONAL MUNICIPALITY OF PEEL  
 REGIONAL MUNICIPALITY OF YORK  
 REGIONAL MUNICIPALITY OF DURHAM  
 COUNTY OF WELLINGTON

SCALE: 1:650,000  
 WHEN PLOTTED CORRECTLY AT 11 x 17  
 NAD 1983 UTM Zone 17N

**PARKS CANADA AGENCY**  
 ENVIRONMENTAL STANDARDS AND GUIDELINES DOCUMENT  
**TRENT-SEVERN WATERWAY**

June 30, 2017	Rev <b>0.0</b>	Figure No.
Project No. 209.40404.00000		<b>3</b>

SLR  
 global environmental solutions



### ***Respecting Indigenous People's Rights and Interests***

The Rideau Canal and Trent-Severn Waterway lie within the traditional territories of several Indigenous communities and are within Treaty areas. For Contractors, sub-contractors and their employees this means that the work carried out will be subject to Treaty obligations. While these obligations stem from the nation to nation requirements found in the Treaties, work and actions by Contractors can play a direct role in ensuring that Treaty obligations are met. Many sites can be important for their Indigenous heritage values; including the protection and preservation of the natural and cultural environments, and ensuring the cultural history of the Indigenous peoples is not lost. Identification, protection and proper treatment of any such cultural resources that may be found at work sites is important to Parks Canada. This protection and preservation leads to reconciliation between Canada and the Indigenous peoples and is at the forefront of our collective work together.

Contractors will need to be aware and respectful of PCA's commitments arising from PCA's consultation and the need for ongoing communications, involvement of Indigenous peoples in their projects, and the implementation of various forms of accommodation. Although Contractors and their agents must not undertake any consultation with Indigenous communities or groups without prior authorization by PCA, Contractors and their agents may be called upon to support PCA management in further consultation in a variety of situations. Overall, any person or organization undertaking a project on Ontario Waterways must respect Indigenous rights and interests.

### ***Protecting Ecological Integrity***

The Rideau Canal Corridor is part of the Great lakes - St. Lawrence Lowlands ecosystem. The Canal crosses several major geological and physiographic regions and traverses the Rideau and Cataraqui watersheds. The Trent-Severn Waterway also crosses several major geological and physiographic regions. In the north, the Severn River and part of the Kawartha Lakes lie on the Canadian Shield. South of the Shield the Waterway traverses a zone of limestone plains passing through the Peterborough drumlin field and the east end of the Oak Ridges Moraine near the Bay of Quinte. Construction projects will need to be planned and designed in a manner that considers its unique physical and environmental setting. Construction technologies or activities used at one site may not be suitable at another.

Both the Rideau Canal and the Trent-Severn Waterway corridors are characterized by an extensive array of lakes and rivers; forested areas and unique terrestrial habitats; marshes, swamps and aquatic vegetation that are utilized by migratory and resident birds (particularly waterfowl and marsh birds), small mammals, amphibians, reptiles and several species of fish. Many Species at Risk (SAR) utilize these habitats for their various life-stages. Many sites contain critical habitat for SAR species.

Although many of the mitigation measures needed to protect these species and their habitats will have been identified during the Environmental Impact Assessment (EIA) process, Contractors will need to ensure that these mitigation measures are implemented and effective. Special attention will need to be given to the development of management plans that address vegetation, wildlife, fish and fish habitat protection (including SAR) and invasive species management. In most instances, projects schedules will need to abide by relatively stringent timing windows to protect fish during spawning and migratory birds during their nesting period. Construction schedules will need to be developed to ensure that key structures, facilities,



equipment and systems critical to environmental protection have been installed and are functioning effectively.

### ***Water Management***

Water management has been an integral part of the operations of the Rideau Canal and the Trent-Severn Waterway for decades to meet the competing interests for the water in the system – navigation, flood control, recreation, water power, fish and wildlife, water supply and water quality. Water management is also undertaken in relation to water power generation facilities. There are twenty-six (26) water power facilities on lands or waters administered by PCA. PCA currently licences the occupation and operation of twenty (20) of these facilities on the Trent-Severn Waterway and the Rideau Canal under the authority of the *Dominion Water Power Act*. Typically, facilities that predate this *Act's* establishment in June 6, 1919 are not subject to the *Act* and its Regulations. As such, six (6) water power facilities are not currently under licence.

Construction projects will need to be implemented in a manner that minimizes disruption to these important functions and interests. Management of water flow is paramount for both operational and environmental reasons. Projects undertaken during navigation season will need to ensure that works or activities do not impeded navigation in the waterways.

### ***Regulatory Compliance***

PCA, its Contractors or their agents must have regard for, and remain in compliance with all applicable federal, provincial and municipal legislative requirements throughout the duration of any project, from its initial design through construction, project completion / close-out.

Of particular importance is the Historic Canals Regulation<sup>1</sup> administered by PCA. The Regulation is intended to assist in the maintenance, management and protection of historic canals. Authorization for work to be completed in water and on land within historic canals is under the authority of PCA. Contractors and their agents will require a permit from PCA prior to mobilization to the site and the commencement of any physical works or activities on the Rideau Canal and/or the Trent-Severn Waterway. The permit will be based on the completed Environmental Impact Assessment (EIA), an accepted site-specific Environmental Management Plan (EMP) and a site-specific Health and Safety Plan. A Contractor's EMP will need to demonstrate their understanding of the legislative context and PCA's Environmental Standards and Guidelines, and how their proposed works and activities will be undertaken to ensure compliance. The regulation gives PCA the authority to issue a stop work order if the work fails to comply with the terms and conditions specified in the permit. Failure to fully disclose all works and activities and phasing, or failure to prepare an acceptable EMP may result in project delay.

In general, Provincial legislation is not applicable to projects undertaken on federal lands. Nevertheless, PCA, its Contractors or their agents should be aware and have regard for Provincial legislative requirements throughout the duration of any project, from its initial design through construction, project completion / close-out. There may also be circumstances where certain project works or activities are undertaken on non-federal lands (e.g., private or municipal leased properties, Provincial Crown lands). In such instances, Provincial legislative

---

<sup>1</sup> Historic Canals Regulations (SOR/93-220) (last amended June 5, 2015). Available from the Department of Justice Canada website: <http://laws-lois.justice.gc.ca/eng/regulations/SOR-93-220/index.html>



requirements would apply and permits and approvals required by the Province must also be included in the EMP.

While municipal requirements are not applicable on federal lands, there may be instances where a project requires municipal or private lands off federal property, where the project relies on municipal services (e.g., waste management, water and sewage, storm sewers, electric utilities, fire and emergency services, roads/transportation) or where project effects (e.g., noise, dust, traffic) extend off-site.

Table 2 lists the relevant federal and provincial legislation for project on Ontario Waterways. Appendix B provides further details regarding each of these *Acts* and/or regulations.

**Table 2: Relevant Federal and Provincial Legislation for Projects on Ontario Waterways**

<b>Jurisdiction</b>	<b>Name</b>	<b>Responsible Agency</b>
<b>Federal Legislation</b>	<i>Parks Canada Agency Act</i>	Environment and Climate Change Canada
	<i>Canada National Parks Act</i>	Parks Canada Agency
	Historic Canals Regulation	Parks Canada Agency
	<i>Navigation Protect Act</i>	Transport Canada
	<i>Canadian Environmental Assessment Act, 2012</i>	Canadian Environmental Assessment Agency
	<i>Fisheries Act</i>	Fisheries and Oceans Canada
	<i>Species at Risk Act</i>	<ul style="list-style-type: none"> <li>• PCA on PCA lands and waters;</li> <li>• Environment and Climate Change Canada on land; and</li> <li>• Fisheries and Oceans Canada in aquatic environments.</li> </ul>
	<i>Migratory Birds Convention Act</i>	Environment and Climate Change Canada
	<i>Canadian Environmental Protection Act</i>	Environment and Climate Change Canada
	<i>Transportation of Dangerous Goods Act</i>	Transport Canada
	<i>Explosives Act</i>	Natural Resources Canada
<b>Provincial Legislation and Municipal Requirements</b>	<i>Ontario Environmental Assessment Act</i>	Minister of the Natural Resources and Forestry
	<i>Ontario Invasive Species Act</i>	Minister of the Natural Resources and Forestry
	<i>Lakes and Rivers Improvement Act</i>	Minister of the Natural Resources and Forestry
	<i>Ontario Water Resources Act</i>	Minister of Environment and Climate Change
	<i>Ontario Conservation Authorities Act</i>	Minister of the Natural Resources and Forestry (Administered by Conservation Authorities)
	<i>Ontario Municipal Act</i>	Ministry of Municipal Affairs
	Municipal By-laws	Local municipality



### ***Socio-economic Considerations***

The Rideau Canal corridor and Trent-Severn Waterway are both extensive in size, diversity of land uses and opportunities and, as such, support a varied social and economic environment. Both the Rideau Canal and the Trent-Severn Waterway are popular recreation destinations and today, tourism and recreation are the most important economic activities on the Canal and the Waterway throughout the year. Access to the Canal and Waterway is possible at all of the Canal's lock stations and by way of marinas, resorts, public boat launches, parks and conservation areas. Users and land based visitors to PCA's facilities number in the millions per year.

Some construction projects will need to be undertaken with tourists and recreational users on-site or in the immediate vicinity. Contractors will need to plan their activities carefully to minimize their construction site's footprint and disruption to tourism and recreational activities, both on-site and off-site. Similarly, many project sites are within communities or near residential homes and business operations. Construction projects will need to be implemented in a manner that minimizes disruption to community character / aesthetics, people's use and enjoyment of property and business activity. Management plans will be needed to minimize noise and dust emissions, effects on drinking water supplies, etc.

### ***Stakeholder Involvement***

The ongoing management of the Rideau Canal and Trent-Severn Waterway is closely tied to the various governments and regulatory agencies involved in development approvals within the corridor. These include the surrounding municipalities, Provincial government departments and agencies (e.g., Ontario Ministry of Natural Resources and Forestry, Ontario Ministry of Environment and Climate Change, Conservation Authorities, etc.); Federal government departments and agencies (e.g., National Capital Commission, Fisheries and Oceans Canada, etc.). There are numerous Indigenous communities with interests in the corridor. There are also numerous private landowners residing or operating commercial and industrial operations within the corridor that require consideration in the management of the Canal. In this context, PCA's primary interests are the retention and enhancement of the natural, cultural and scenic values (heritage character) of the Canal waterfront lands. On federal lands, PCA will always be the principle point of contact when engaging stakeholders.



## **4.0 PCA'S PROJECT DELIVERY PROCESS**

Figure 4 presents an overview of PCA's project delivery process. For the purposes of this ESG Document, the process is comprised of seven (7) key stages:

1. Project Initiation;
2. Concept Stage;
3. Planning and Design;
4. Construction Tendering;
5. Pre-Construction and Submittals;
6. Construction; and
7. Project Completion and Close-out.

This ESG Document applies primarily to stages three (Planning) to seven (Project Completion and Close-out) of PCA's project delivery process.

### **4.1 Contractors' Environmental Responsibilities in Project Delivery**

In general, Contractors are retained by PCA (and/or Owner's Engineer) or the Contract Administrator to furnish of all labour, materials and equipment required to complete the project within the scope of their work. For some projects, Contractors may also be expected to obtain all necessary permits, authorizations and licences to perform work. In all cases, Contractors are expected to complete the project in accordance with its design and fulfill their environmental responsibilities in accordance with the requirements of the Historic Canal Regulation Permit, including their EMP.

#### **4.1.1 Planning and Design**

During the Planning and Design stage, project planners, engineers and Contractors should incorporate the information provided in this ESG Document into the EIA, project plans, designs and contract specifications. For example, coffer dams should be designed at this stage to a sufficient level of detail that would permit a review by PCA and/or DFO. PCA may choose to set general parameters or site-specific design constraints. PCA may also choose to impose site-specific prohibitions at this time (e.g., no loose aggregate is to be used for coffer dams).

#### **4.1.2 Construction Tendering**

During the Construction Tendering stage, Contractors are encouraged to have a Qualified Professional(s) provide input to the Contractor's bid taking into consideration known environmental and design constraints (e.g., PCA's EIA results and design assumptions), and PCA's Environmental Standards and Guidelines Document. This would help ensure that PCA's environmental requirements have been taken into consideration in project costing and scheduling.

**Figure 4: PCA's Project Delivery Process Summary**

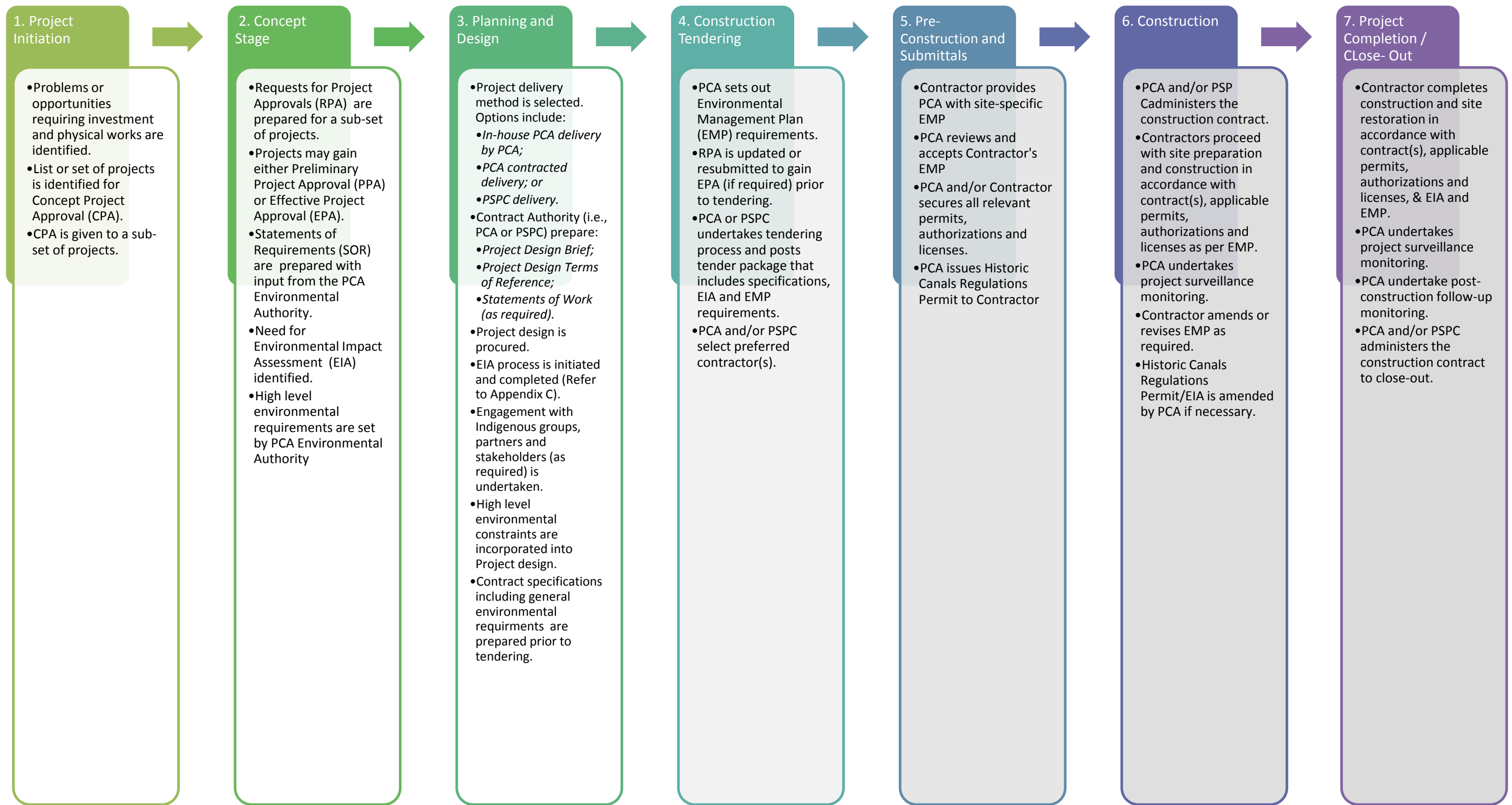

This ESG Document primarily applies to steps the Construction Tendering, Pre-Construction/Submittals, Construction and Project Completion/Close-Out stages of PCA's project delivery process. This ESG Document can also be useful in the completion of an Environmental Impact Assessment during the Planning and Design stage.



#### **4.1.3 Pre-Construction and Submittals**

During the Pre-Construction and Submittals stage (after contract award), Contractors are required to have a Qualified Professional(s) prepare a site-specific EMP detailing all proposed structures, facilities, equipment and systems critical to environmental protection; all proposed mitigation measures, monitoring and follow-up activities; all relevant standards and guidelines; and, all performance criteria applicable to the project. Section 5 of this ESG Document provides PCA's requirements for a site-specific EMP.

The Contractor's site-specific EMP must be submitted to PCA's Environmental Authority and the Departmental Representative. The site-specific EMP must be reviewed and accepted by PCA prior to mobilization to the site and the commencement of any work. In addition, the Contractor will prepare a project-specific Health and Safety Plan (HASP). All employees working on the site must be suitably trained and experienced and the Contractor must fully comply with all federal and provincial health and safety standards.

#### **4.1.4 Construction and Project Completion**

During the Construction and Project Completion stages, Contractors must:

- Comply with all relevant legislative requirements and other requirements specified in the accepted EMP/EIA. In addition, Contractors must ensure that their workers and sub-Contractors are appropriately trained, supervised and have the necessary experience and competency to implement the requirements of the EMP/EIA;
- Review the EMP/EIA with their staff and sub-Contractors prior to commencing works and following incidents requiring corrective action;
- Cooperate with PCA's Environmental Authority, the Departmental Representative or designate (e.g., Environmental Monitor) appointed for the work;
- Comply with all written or verbal instructions with respect to conducting activities in compliance with the EMP/EIA; and
- Take corrective actions for any non-compliance issues upon direction from PCA's Environmental Authority or designate whether written or verbal. Corrections should be made as soon as reasonably possible, ideally within 24 hours of directions unless there is urgent/immediate action required due to serious and ongoing impacts to the environment.

Contractors are expected to be on site during execution of work and communicate directly to and be under the direction of the Departmental Representative or designate. It is required that the Qualified Professional(s) that prepared the EMP or relevant component plans be available on-site for the inspection, testing and maintenance of structures, facilities, equipment and systems critical to environmental protection in order to ensure compliance with the EMP/EIA. The EMP shall propose for PCA's acceptance, the frequency of monitoring and list "high-risk" construction activities where the relevant Qualified Professional(s) must be on-site. Examples of "high-risk" construction activities are:

- Installation and removal of coffer dams;
- Dewatering;





- Blasting;
- Pile Driving;
- Concrete pours (Tremie concrete pours in particular);
- Fish salvage and relocation; and
- Dam commissioning.

Qualified Professional(s) must also be on-site to address any SAR encounters during construction.

The Qualified Professional(s) should not only be on-site for scheduled monitoring or during “high-risk” construction activities, but should remain on-call during non-critical work periods to respond to emerging environmental issues.

Contractors must give PCA’s Environmental Authority a minimum of 48 hours’ notice before any “high-risk” construction activity is to be undertaken. Any ‘high-risk’ activities identified in the EMP will not be allowed to proceed unless notice requirements have been fulfilled. PCA may choose to be on-site or allow the work to proceed under the supervision of the Qualified Professional(s) on-site.

The Contractor must allow PCA’s Environmental Authority or their designate access to the work site for surveillance and inspections. Contractors must comply with any direction regarding non-compliance identified by PCA’s Environmental Authority or Departmental Representative and report compliance to PCA.

The Contractor must report any environmental incidents to the PCA’s Environmental Authority and the Departmental Representative. An environmental incident is any event, act or omission that is, or has the potential to cause, a violation of any of the EMP/EIA provision, any environmental legislation, or provisions of any other permits, authorizations and approvals issued for the project. The works or activities causing the incident should be stopped and the environmental effects should be mitigated immediately once the incident has been identified. Examples of environmental incidents include, but are not limited to:

- Spills of oil, fuel, hazardous chemicals;
- Unauthorized discharges of deleterious substances (including sediment) into fish-bearing water bodies;
- Unauthorized alteration, disruption, or destruction of aquatic or terrestrial habitat (e.g., encroachment into prohibited areas, removal of vegetation during nesting periods);
- Alteration of, or damage to, heritage or archaeological resources (uncovering previously unknown artifacts);
- Fires related to construction activities; and
- Unauthorized release of air pollutants.

As outlined in Part 2 of this ESG document (see Refueling and Spill Management – ESG-13-C):

- Any spill into water, onto ice or in a dewatered area must be reported immediately to PCA’s Environmental Authority, the Departmental Representative and the Ontario Ministry of Environment and Climate Change’s Spills Action Centre (SAC).



- Any spill on land must be reported immediately to PCA's Environmental Authority and the Departmental Representative. Any spill on land meeting the criteria set out in Ontario's *Environmental Protection Act*, O. Reg. 675/98 must be reported immediately to the Ontario Ministry of Environment and Climate Change's Spills Action Centre (SAC).
- All areas affected by a spill must be cleaned up and demonstrated to be restored to pre-spill condition by a Qualified Professional(s).

## **4.2 PCA's Environmental Responsibilities in Project Delivery**

PCA is ultimately responsible for the identification, design, tendering, construction and completion of its own projects. As the environmental regulator, PCA is also responsible for ensuring that its environmental procedures, standards and guidelines are implemented throughout project delivery.

### **4.2.1 Project Initiation and Concept Stages**

During the Project Initiation and Concept stages, PCA identifies those projects that are proposed to be undertaken over the next several years and seeks Concept Project Approval (CPA). Potential projects can be identified in a variety of ways such as: ad hoc or formal inspections of assets by PCA staff, engineering inspections and studies, etc. PCA would then seek either Preliminary Project Approval (PPA) or Effective Project Approval (EPA). Prior to approval, PCA would consult with various subject matter experts, initiate consultation partners, stakeholders and Indigenous communities (as required). Often further studies and investigations are undertaken to better define the project, in terms of scope, budget, schedule. PCA's Environment Authority provides input into Concept Stage studies by identifying high level environmental constraints and requirements applicable to the construction activities at the project site.

### **4.2.2 Planning and Design**

Depending upon the size and complexity of the project, PCA may undertake the work themselves or contract out the work. PCA may contract with an "Owner's Engineer" (i.e., the Contractor) who typically undertakes more detailed project planning, engineering design, project construction, supervision of construction sites and project completion in accordance with its contract.

For larger, more complex projects, PCA may involve Public Services and Procurement Canada (PSPC) to provide them with consulting services and/or taking on the role of the Departmental Representative and/or Contract Administrator. When required, the Departmental Representative or Contract Administrator typically manages all aspects of the project, including: initial tendering and contract award, project development through all phases of project development (i.e., site preparation, construction, site restoration); scheduling and financial matters. In this case, PCA will have a project leader assigned to the work to act as liaison between PCA and PSPC. In any event, PCA remains the Environmental Authority on all projects.

During the Planning and Design stage, PCA's environmental responsibilities include initiating and completing PCA's Environmental Impact Analysis process to ensure the project is not likely to result in significant adverse environmental effects, and/or public concern with respect to ecological integrity, the integrity of cultural resources or characteristics of the environment that



are important to key visitor experience objectives. The EIA process is typically undertaken at the 33% to 66% (and finalized at 99%) project design level to understand how the design and project components may impact the VEC's identified in the EIA. This ESG Document should be used to identify key mitigation measures for inclusion in the EIA. PCA continues fulfilling its Indigenous community consultation requirements and engagement activities with its partners and stakeholders.

The EIA process will result in a set of environmental requirements (i.e., mitigation measures) that will form the basis of the Historic Canals Regulations Permit issued to the Contractor. These environmental requirements will also need to be incorporated into the Contractor's EMP and implemented by the Contractor for Construction, Project Completion and Close-out stages. The EMP is necessary to explain how the Contractor will achieve compliance with the EIA, provisions of any permits, authorizations and approvals issued for the project and PCA's Environmental Standards and Guidelines.

PCA may require follow-up monitoring if there is uncertainty regarding the prediction of adverse environmental effects or the effectiveness of mitigation measures, or in accordance with legislative requirements (such as species at risk monitoring under SARA). Follow-up monitoring may commence at any time following EIA approval and may continue after the construction is completed. This will be done by PCA. [Appendix C](#) provides an overview of PCA's EIA process.

Finally, during the Planning and Design stage, PCA's environmental responsibilities also include providing input into the tendering process by preparing its detailed environmental requirements or specifications.

#### **4.2.3 Construction Tendering**

During the Construction Tendering stage, PCA's environmental responsibilities include setting out its overall environmental requirements (including EMP requirements) for Contractors to follow in preparing their bids. PCA may attach the EIA and this ESG Document to the tender package that is made available to prospective Contractors and/or communicate its requirements to them by other means. This stage concludes with the selection of the preferred Contractor(s) by PCA and/or PSPC.

#### **4.2.4 Pre-Construction and Submittals**

During the Pre-Construction and Submittals stage, PCA would receive, review and accept a Contractor's site-specific EMP, ensuring that its environmental requirements or specifications as set out in the tender documents, the EIA, project approvals and permits, and this ESG Document have been incorporated adequately.

PCA and/or the Contractor would secure all relevant permits, authorizations and licenses to allow the project to proceed. As per the Historic Canal Regulations applicable to lands administered by PCA, a permit would be issued by a Parks Canada Director to authorize the project work prior to mobilization to site and the commencement of the Construction stage.

#### **4.2.5 Construction and Project Completion**

Throughout the duration of the Construction and Project Completion stages, PCA is typically responsible for the day-to-day management of the technical and engineering aspects of the project from its inception to completion. The PCA's project manager communicates regularly



and works directly with the Contract Administrator, Public Services and Procurement Canada (PSPC), the Owner's Engineer and/or the Construction Contractors in project delivery. In addition, PCA will:

- Lead communication with regulatory agencies, local governments, interested and potentially affected Indigenous Groups, and public stakeholders, including property owners and local residents on federal land; and
- Audit compliance with the requirements of the EMP and EIA.

As the Environmental Authority, PCA typically assigns a staff person (or team) or external Consultant to the project whose role is to ensure that the Contractor complies with the project's design specifications and the requirements of the Historic Canal Regulation Permit, as well as the EMP and EIA.

This role can be fulfilled by PCA's Environmental Assessment Officer or designate (e.g., Environmental Monitor/Consultant) who is typically an engineer, applied scientist or technologist who is registered and in good standing with an appropriate professional organization or who, through demonstrated experience and knowledge relevant to the particular matter, may be reasonably relied on to provide advice within their area of expertise. Such a professional could be an ecologist / biologist, forester, geoscientist, engineer, or technologist. An Environmental Monitor operates independently of the proponent and Contractors.

The specific tasks to be completed by the PCA Environmental Authority, the Environmental Monitor/Consultant will depend on the project construction activities and will generally include, but not necessary be limited to:

- Confirming that construction personnel are aware of site-specific environmental issues and all environmental requirements set out by PCA, including requirements set out in EIA and relevant Environmental Standards and Guidelines. Contractors must keep records of all training activities undertaken with construction staff;
- Surveillance monitoring of construction activities and documentation of environmental concerns and environmental protection measures undertaken (see below);
- Completion of on-site meetings and review of specific EMPs with on-site Contractor and/or construction supervisor;
- Review of the working conditions of environmental protection measures (e.g., erosion and sediment control measures) to ensure that they have been installed, are being maintained and are functioning effectively;
- Identifying and communicating to the Contractor issues of non-compliance;
- Development of site-specific protocols or corrective actions for the management of selected issues of non-compliance; and
- Coordination and completion of surveillance monitoring reports, incident / non-compliance reports, and photo documentation of construction works.



#### 4.2.5.1 PCA's Surveillance Monitoring

As mentioned above, at any time, during the project's implementation, PCA's Environmental Authority or designate (e.g., an Environmental Monitor/Consultant) may undertake a site visit to undertake surveillance monitoring.

Contractors can expect that surveillance monitoring shall be undertaken at a frequency based on specific work tasks/procedures and the potential for adverse impacts to occur. At a minimum, surveillance monitoring would occur during "high-risk" construction activities. Contractors must give PCA's Environmental Authority a minimum of 48 hours' notice before any "high-risk" construction activity is to be undertaken. Any "high-risk" activities identified in the EMP will not be allowed to proceed unless notice requirements have been fulfilled.

Surveillance monitoring may also be conducted with greater frequency during or following periods of inclement weather (i.e., heavy precipitation, strong winds, ice storms).

Documentation of all site visits and discussions with proponents, Contractors or their agents is essential. Documentation of each surveillance monitoring event shall be undertaken according to PCA's template that documents:

- Relevant project and inspection related information (e.g., location, inspection date and time, individual conducting and present at the inspection, work-site contact information and stage of project implementation and weather conditions)
- Site conditions and inspection methods, noting any specific focus of the inspection
- Surveillance results (i.e., observations, evidence and conclusions regarding whether relevant measures have been correctly implemented), including photos
- Recommendations for improvements (if any);
- Corrective actions required (if any); and
- Summary of identified issues, potential effects and actions.

Documentation of the site visit shall occur after each site visit.

#### 4.2.5.2 Non-Compliance Procedures

Any cases of non-compliance noted during surveillance will be reported PCA's Environmental Authority or designate (e.g., Environmental Monitor/Consultant) and to the Departmental Representative and the Contractor.

The Environmental Authority and/or the Departmental Representative may require the Contractor to take corrective actions and ensure completion of any such requirements. Corrective actions may be communicated direct to the Contractor by PCA's Environmental Authority (or designate) or through the Departmental Representative for minor infractions or cases of non-compliance. In circumstances where immediate corrective action is required to prevent environmental or property damage and the Departmental Representative is not accessible, the corrective action requirements will be communicated directly to the Contractor/employees conducting the work.



PCA's Environmental Authority (or designates) or the Departmental Representative may stop work (i.e., of a specific activity where circumstances warrant) until satisfactory corrective action has been taken. Circumstances where a stop work order may be warranted include where there is:

- An imminent or clear contravention of legislative or regulatory requirements with the potential for a significant adverse effect from a project work or activity;
- An imminent or clear threat to human health and safety or contravention of a health and safety protocol; and
- Imminent or clear damage to property; or where the previously requested corrective action has not been taken to the Departmental Representative's satisfaction.

PCA's enforcement officers, such as Park Wardens, and other federal or provincial enforcement officers (e.g., Environment Canada, DFO, MOECC, and MNRF) can play an advisory role to PCA staff and assist with enforcement actions related to environmental legislation within their mandates and jurisdiction. Local police services are the primary enforcers of the Criminal Code. Assistance can be in the form of investigating complaints of non-compliance, taking enforcement actions, preparing files for court briefings, ensuring continuity of evidence, and undertaking consultations with the legal services.

#### **4.3 Other Players and their Responsibilities**

PCA works collaboratively with relevant federal, provincial and municipal government agencies throughout project planning, development and follow-up. Upon request by PCA, other government agencies can make available their specialists, expert information or knowledge that they possess with respect to a project. This expertise may be used by PCA during any stage of project planning and environmental assessment, from the commencement of the project to the implementation of the mitigation measures or any follow-up program. In some instances (e.g., projects affecting non-federal lands or municipal infrastructure) other provincial and municipal governments may be required to grant an approval. All approvals granted must be provided to PCA and integrated into the Contractor's EMP.

Typically, Indigenous communities become involved on specific projects on Ontario Waterways during the Environmental Assessment process or earlier. Depending on the project and its environmental effects, their involvement may extend to working with PCA in follow-up and monitoring activities. PCA will be the lead in any communications with Indigenous communities.

The general public and other stakeholders become involved on specific projects on Ontario Waterways during the Environmental Assessment process or earlier. Public consultation is mandatory for Detailed Impact Assessments (DIA) and optional for Basic Impact Assessments (BIA). PCA and its Contractors endeavor to keep its neighbours and the general public notified of upcoming projects and the status of project development, particularly in cases where navigation, road use or access to private property is affected.

Contractors or their agents are prohibited from consulting with federal, provincial and municipal government agencies or Indigenous communities without prior approval by PCA for project components on federal lands. If leasing properties, then consultation with other relevant government agencies may be undertaken by the Contractor.



## 5.0 ENVIRONMENTAL MANAGEMENT PLANS

The Contractor is required to prepare and submit to PCA a site-specific EMP detailing all proposed methods, strategies, structures, facilities, equipment and systems critical to environmental protection; all proposed environmental protection and mitigation measures, monitoring and follow-up activities; all relevant standards and guidelines; and, all performance criteria applicable to the project. The Contractor's EMP must be prepared by a Qualified Professional(s), signed and submitted to PCA, for review and acceptance prior to mobilization to site and the commencement of work. An accepted EMP (accepted by PCA) is required prior to the release of the Historic Canals Regulations Permit issued to the Contractor.

An EMP is a project-specific and site-specific document, based on the site-specific EIA, that contains a set of over-arching EMP requirements plus a set of highly specific component plans that, when implemented collectively as a management system, are intended to avoid, eliminate or reduce the severity of adverse environmental effects. The site-specific EMP shall serve as a reference document for all project personnel, so that they are aware of their responsibilities and what is expected of them concerning environmental protection. The requirements included in the EMP will apply to any person, Contractor or subcontractor involved in the project. It is intended to be a "living" document that may require amendments as the project advances from design through construction. These amendments must follow the submittal and acceptance process to PCA, prior to any changes. For example, a dam commissioning plan may be conceptual during initial stages of construction, but would become highly specific prior to commissioning activities being undertaken. Failure to fully disclose all construction works and activities and phasing, or failure to prepare an acceptable in the EMP may result in project delay.

### 5.1 Overall EMP Requirements

The over-arching EMP document shall include a description of:

- The purpose and scope of the EMP;
- A project overview;
- A construction plan and schedules;
- The roles and responsibilities of the environmental management team;
- Environmental awareness, training and competency commitments;
- General communications and record keeping commitments;
- Environmental incident reporting procedures;
- Environmental monitoring and adaptive management summary; and
- EMP review and revision procedures.

As necessary, the over-arching EMP document should refer to relevant component plans (see Table 3) and other documents at higher or lower levels in the Contractor's management system. Higher level documents may describe environmental management policies and processes. Lower level documents may describe general procedures, specific operational procedures, activity specific work-procedures and work instructions, equipment manuals, environmental protection procedures.



### **5.1.1 Purpose and Scope of the EMP**

The site-specific EMP shall include statements that describe its purpose and the scope:

- The purpose statements should demonstrate how the Contractor understands the relationship between the EMP, the legal requirements applicable to the Project, and the work to be completed.
- The specific Project works and activities to which the EMP will be applied, including any particular limitations such as Property boundaries (spatial scope); time (temporal scope); or limitations with respect to particular works or activities.

### **5.1.2 Project Overview**

The site-specific EMP shall provide an overview of the project that includes:

- A description of the overall Project and its objectives;
- A location map that references the project location in relation to area municipality(ies), communities, transportation network and other local features (e.g., Provincial parks, conservation areas, etc.);
- A detailed Project site map that provides:
  - Property boundaries for all locations on which Project activities will be undertaken (including any leased properties),
  - Site entrance locations,
  - Locations of all PCA's assets,
  - Key environmental, socio-economic and culturally significant features<sup>2</sup>, and
  - Site contours and expected drainage patterns.

### **5.1.3 Construction Plan and Schedules**

The site-specific EMP shall provide a construction plan and schedules that include:

- A detailed description of all physical works, activities to be undertaken and materials to be used;
- A listing and rationale for any “high-risk” construction activities;
- An overall Project or construction schedule;
- Detailed supporting schedules and/or information that provides the following:
  - time periods / seasons identified as sensitive for environmental reasons (i.e., timing windows for fish, migratory bird nesting, Species at Risk, fire season, winter, etc.),
  - times where noise may be a nuisance to local residents or at a specialized land use (e.g., such as a hospital, school, retirement home) or when construction may create any parking, access and/or traffic problems,

---

<sup>2</sup> Key environmental, socio-economic and culturally significant features can be obtained from the Environmental Impact Assessment documentation prepared for the Project.





- the duration of specific physical works and activities (e.g., vegetation clearing, topsoil stripping, coffer dam installation and removal, concrete works, site restoration),
- timing of “high-risk” construction activities, key mitigation measures, including timing regarding the installation of key structures, facilities, equipment and systems critical to environmental protection,
- timing of any special studies or the submission of further EMP component plans,
- the Contractor’s site surveillance schedule by their Qualified Professional(s), linked to “high risk” construction activities, and
- a consultation schedule (if applicable).

#### **5.1.4 Roles and Responsibilities of the Environmental Management Team**

A site-specific EMP shall include a description of the organizational structure for the planned work or activities which clearly explains:

- Environmental management team members and their roles;
- Their relationship of each team member to each other;
- Their relationship to PCA personnel; and
- The contact information and position of the person(s) responsible for preparing the EMP and of the key persons responsible for implementing it.

Identifying the position(s) responsible for the EMP includes indicating who within the Contractor’s organization has responsibility and authority for its implementation, ongoing maintenance, performance monitoring and continuous improvement. The EMP shall describe, at an operational level, how the environmental management team and personnel will implement the EMP on a day-to-day basis. Reporting relationships and structures are most easily understood when represented in organization charts. The Contractor is encouraged to use organization charts to explain these relationships.

It is required for the Contractor to hire Qualified Professionals that can provide services thought the life of the project, particularly for monitoring of “high risk” construction activities.

#### **5.1.5 Environmental Awareness, Training and Competency**

The site-specific EMP shall refer to the policies, plans and procedures for communicating Project specific environmental protection matters within the Contractor’s organization and to Sub-Contractors entering the worksite. Task specific training will be provided to all Sub-Contractors or suppliers (e.g., Refueling standards and guidelines should be communicated to the supplier entering the site).

The EMP should also summarize and/or reference how environmental awareness training will be provided for all construction personnel, and should summarize and/or reference the procedures to ensure that personnel in environmentally critical roles are qualified and competent. This includes requirements for both training and competency assessments. Records of training must be given to PCA.



### **5.1.6 General Communications and Record Keeping**

A communications protocol is required as part of the site-specific EMP. The EMP shall describe and/or reference:

- The environmental management team members that are authorized to communicate with PCA.
- The communication methods to be used to allow PCA to receive updates throughout the project to reflect changes in project scope, construction methods, scheduling, site conditions, and weather-related contingency measures. PCA must be informed of any proposed changes that may require an amendment to the EIA and/or EMP.
- The procedures for the reporting of all environmental incidents to the PCA Project Manager (or designate) for the investigation of all such incidents to find the underlying or root causes, and for the identifying of remedial actions to prevent future recurrence of the incident or similar incidents in the future.
- The types of records that are to be maintained to demonstrate environmental protection and compliance with the EMP and where to find these records for auditing purposes.

### **5.1.7 Environmental Incident Reporting**

The site-specific EMP shall describe the reporting procedures for environmental incidents. At a minimum, the procedure would include commitments to:

- Report all environmental incidents to PCA's Environmental Authority and the Departmental Representative and any other regulatory authority if required by statute to be reported.
- Provide a written environmental incident investigation report that includes appropriate photo documentation and describes the:
  - Nature of the incident;
  - Approximate magnitude and duration of the incident;
  - Areas, resources or habitats affected;
  - Results of any sample analysis taken in conjunction with the incident (e.g., water samples);
  - Root cause(s) of the incident;
  - Immediate actions taken on-site to mitigate adverse environmental effects;
  - Recommended preventive and corrective actions to control or limit the activity or circumstances causing the incident, including a time frame for implementation;
  - Communications held with the Contractor's employees, PCA's Environmental Authority, the Departmental Representative and other regulatory agencies (if applicable).
- All environmental incidents shall be reported as soon as reasonably possible. Spills must be reported within 24 hours (see Refueling and Spill Management – ESG-13-C).

### **5.1.8 Environmental Monitoring and Adaptive Management Summary**

Each site-specific EMP component plan shall include a description of monitoring and reporting requirements relevant to the specific component plan contents. These component plans shall:



- Define project and site-specific objectives (e.g., performance / compliance monitoring, effectiveness monitoring);
- List the applicable legislative and regulatory requirements;
- Tabulate applicable EIA commitments, terms and conditions of approval and relevant environmental standards and guidelines;
- Describe the scope of environmental monitoring, including:
  - Monitoring objectives,
  - Location(s) to be monitored,
  - Parameters to be monitored,
  - Methods, and
  - Duration and frequency of monitoring;
- Equipment to be used and its maintenance/calibration schedule;
- Describe reporting requirements (e.g., event reports, monthly reports, annual reports); and
- Provide cross-references to other component plans.

These monitoring plans and approaches to adaptive management shall be summarized within the over-arching EMP document.

Adaptive management is a planned and systematic process for continuously improving environmental management practices by learning about their outcomes. Adaptive management provides flexibility to identify and implement new mitigation measures or to modify existing ones during the life of a project. Adaptive management approaches shall be specific to relevant component plans and shall discuss (where appropriate) the following:

- Identification of key indicators that may serve as a gauge of ecological conditions within the area of the project;
- Identification of action thresholds to be used to indicate when environmental performance is approaching and/or below an acceptable level and requires corrective management action.
- Identification of testable predictions or hypotheses to provide a basis for understanding why change might be occurring in the environment and how to select adaptive management measures based on those conclusions.
- Identification of adaptive management options to demonstrate that there are a range of available options to adapt and manage the project should a mitigation measure not function as intended. These options should be technically and economically feasible.
- Conditions that would trigger the need for a revisions to the EMP and/or Historic Canals Regulations Permit.

Further guidance regarding adaptive management is available from the Canadian Environmental Assessment Agency (2009)<sup>3</sup>.

---

<sup>3</sup> Canadian Environmental Assessment Agency, 2009. Operational Policy Statement- Adaptive Management Measures under the *Canadian Environmental Assessment Act*. Catalogue No.: 978-1-100-12062-1, ISBN: En106-83/2009E-PDF. Available on-line at: [https://www.ceaa-acee.gc.ca/Content/5/0/1/50139251-2FE4-4873-B6A1-A190C103333D/Adaptive\\_Management\\_Measures\\_under\\_the\\_CEEA.pdf](https://www.ceaa-acee.gc.ca/Content/5/0/1/50139251-2FE4-4873-B6A1-A190C103333D/Adaptive_Management_Measures_under_the_CEEA.pdf)



### **5.1.9 EMP Review and Revision**

The EMP shall specify the procedures for the review and revision of the EMP during Project implementation and have a version control procedure. At a minimum, the site-specific EMP shall be reviewed by the Contractor to determine if an amendment or a major revision is warranted:

- At least once every six (6) months or on a seasonal basis;
- As a result of changes in the project or changes in the anticipated environmental effects of the project;
- After corrective actions have been taken in response to an environmental incident;
- after an adaptive management measure has been proposed by either the Contractor or PCA;
- After a material revision of the EMP has been proposed by either the Contractor or PCA. A material revision is one which would be relevant to the question of whether an adverse environmental effect is more likely to occur, or become more adverse, and be significant;
- After a material revision of the EMP is proposed that changes a commitment such as:
  - a reduction or increase of monitoring or reporting requirements; or
  - making a specification less stringent or more stringent.

Any proposed amendment or revision shall be provided to PCA by the Contractor in writing for acceptance prior to action. Amendments and revisions shall be tracked in accordance with an accepted version control procedure.

PCA may choose to modify its EIA and the Historic Canals Regulations Permit issued to the Contractor on the basis of the proposed amendment or EMP revision.

### **5.1.10 Component Plan Requirements**

Where relevant, the following component plans are to be included in a site-specific EMP. Each component plan will be based on a set of project-specific and site specific objectives. A key requirement of each component plan will be a table that summarizes applicable EIA commitments, terms and conditions of approval and relevant environmental standards and guidelines. The information included in this ESG Document should be used to the extent possible and applicable to the Project. However, the component plans should not be limited to these measures. Contractors will need to augment these standards and guidelines with other measures that are unique to the Project or necessary to address the full range of anticipated Project effects. If there is insufficient detail for a component plan then there should be clear reference as to when the plan will be provided. Work will not commence until PCA acceptance of all relevant component plans.



Component Plan	Primary Objectives
<b>Dust and Air Quality Management</b>	<ul style="list-style-type: none"> <li>To minimize potential effects and disruption to residents, businesses, community facilities, recreational and tourist activities</li> </ul>
<b>Noise, Vibration and Ambient Light Management</b>	<ul style="list-style-type: none"> <li>To minimize potential effects and disruption to residents, businesses, community facilities, recreational and tourist activities</li> </ul>
<b>Transportation Management</b>	<ul style="list-style-type: none"> <li>To minimize disruption to traffic patterns and access to property.</li> </ul>
<b>Blasting</b>	<ul style="list-style-type: none"> <li>To identify blasting procedures and timing, including safety, use, storage, and transportation of explosives.</li> </ul>
<b>Demolition</b>	<ul style="list-style-type: none"> <li>To identify demolition procedures and timing.</li> </ul>
<b>Site Dewatering and Wastewater</b>	<ul style="list-style-type: none"> <li>To control water takings from watercourses, waterbodies or from the ground from entering the construction site.</li> <li>To prevent contaminated water resulting from the dewatering process and wastewater management from being discharged into the environment.</li> <li>To isolate clean off-site water from contaminated construction water and to minimize the volume contaminated water.</li> </ul>
<b>Surface Water Management, Erosion and Sediment Control</b>	<ul style="list-style-type: none"> <li>To control and mandate surface water from off-site and within the project area;</li> <li>To minimize the amount of erosion on-site.</li> <li>To control the amount of sedimentation occurring on-site.</li> <li>To minimize the deposition of deleterious substances to surface waters and minimize sediment input to surface waters.</li> </ul>
<b>Dredging and Sediment Removal</b>	<ul style="list-style-type: none"> <li>To identify the dredging and sediment removal procedures, including storage, transport and disposal of dredged materials.</li> <li>To minimize disturbance and protect aquatic and terrestrial resources.</li> </ul>
<b>Vegetation Protection</b>	<ul style="list-style-type: none"> <li>To minimize and phase disturbance and protect existing native vegetation</li> </ul>
<b>Wildlife Protection and Management</b>	<ul style="list-style-type: none"> <li>To minimize disturbance to wildlife and hazards associated with wildlife.</li> </ul>
<b>Aquatic Resources Management</b>	<ul style="list-style-type: none"> <li>To minimize disturbance and protect aquatic resources, including sensitive species and their habitat.</li> </ul>
<b>Species at Risk Protection</b>	<ul style="list-style-type: none"> <li>To minimize disturbance and protect aquatic and terrestrial Species at Risk and their habitat.</li> </ul>
<b>Invasive Species Management</b>	<ul style="list-style-type: none"> <li>To control the spread of existing invasive plant infestations and prevent new infestations from establishing in the Project area.</li> </ul>



Component Plan	Primary Objectives
<b>Waste Management</b>	<ul style="list-style-type: none"> <li>• To minimize the generation and need for disposal of hazardous and non-hazardous wastes.</li> <li>• To minimize risks to worker and public health and safety.</li> </ul>
<b>Hazardous Materials Management</b>	<ul style="list-style-type: none"> <li>• To identify the procedures for the transportation, storage and safe use of hazardous materials on-site.</li> </ul>
<b>Fuel Management</b>	<ul style="list-style-type: none"> <li>• To minimize the risk of accidents and malfunctions</li> <li>• To minimize risks to worker and public health and safety.</li> </ul>
<b>Spills Prevention and Emergency Response</b>	<ul style="list-style-type: none"> <li>• To minimize the risk of accidents and malfunctions.</li> <li>• To minimize risks to worker and public health and safety.</li> <li>• To minimize disturbance and protect aquatic and terrestrial resources.</li> <li>• To effectively respond to spills and other emergencies on-site.</li> </ul>
<b>Dam and/or Bypass Channel Commissioning</b>	<ul style="list-style-type: none"> <li>• To sets out the process, expectations and the methodology for successful commissioning of a dam.</li> <li>• To minimize the amount of sediment disturbance/transport and aquatic environments during</li> </ul>
<b>Site Restoration</b>	<ul style="list-style-type: none"> <li>• To minimize risks to worker and public health and safety;</li> <li>• To minimize long-term effects on aquatic and terrestrial resources.</li> <li>• To restore site aesthetics and minimize disruption to residents, businesses, community facilities, recreational and tourist activities.</li> </ul>

Table 3 provides PCA’s key requirements for each component plan. Table 4 provides links to the potentially applicable standards and guidelines included in [Part 2](#) of this ESG Document that may assist in the preparation of each component plan.



**Table 3: EMP Component Plans and Key Requirements**

EMP Component Plan	Key Requirements
Dust and Air Quality Management	<p>This component plan shall:</p> <ul style="list-style-type: none"> <li>• Define project and site-specific objectives.</li> <li>• List the applicable legislative and regulatory requirements.</li> <li>• Describe the key sources of dust and air emissions (e.g., equipment, works and activities) associated with the Project.</li> <li>• Identify the locations and provide a description of sensitive receptors.</li> <li>• List the key methods, strategies, structures, facilities, equipment and systems critical to dust and air quality management.</li> <li>• Describe approach to construction site winterization and/or winter operations.</li> <li>• Tabulate applicable EIA commitments, terms and conditions of approval and relevant environmental standards and guidelines (Refer to <u>Part 2</u> of this ESG Document).</li> <li>• Describe the maintenance program for all structures, facilities, equipment and systems critical to environmental protection.</li> <li>• Describe the approach to adaptive management.</li> <li>• Describe monitoring and reporting requirements.</li> </ul>
Noise, Vibration and Ambient Light Management	<p>This component plan shall:</p> <ul style="list-style-type: none"> <li>• Define project and site-specific objectives.</li> <li>• List the applicable legislative and regulatory requirements.</li> <li>• Describe the key sources of noise, vibration and light (e.g., equipment, works and activities) associated with the Project.</li> <li>• Identify the locations and provide a description of sensitive receptors.</li> <li>• List the key methods, strategies, structures, facilities, equipment and systems critical to noise, vibration and ambient light management.</li> <li>• Describe approach to construction site winterization and/or winter operations.</li> <li>• Tabulate applicable EIA commitments, terms and conditions of approval and relevant environmental standards and guidelines (Refer to <u>Part 2</u> of this ESG Document).</li> <li>• Describe the maintenance program for all structures, facilities, equipment and systems critical to environmental protection.</li> <li>• Describe the approach to adaptive management.</li> <li>• Describe monitoring and reporting requirements.</li> </ul>



EMP Component Plan	Key Requirements
Transportation Management	<p>This component plan shall:</p> <ul style="list-style-type: none"> <li>• Define project and site-specific objectives.</li> <li>• List the applicable legislative and regulatory requirements.</li> <li>• List relevant federal, provincial or municipal standards and guidelines related to transportation infrastructure to be affected.</li> <li>• Tabulate applicable EIA commitments, terms and conditions of approval and relevant environmental standards and guidelines (Refer to <u>Part 2</u> of this ESG Document).</li> <li>• Describe approach to construction site winterization and/or winter operations.</li> <li>• Describe the routes to provide safe and efficient movement of vehicles.</li> <li>• Describe timing of road or bridge closures and detour routes.</li> <li>• Location and capacity of parking for staff and construction vehicles.</li> <li>• List policies for the movement of dangerous goods, oversized and regular loads.</li> <li>• List policies for movement of heavy loads on roadways with load restrictions.</li> <li>• Describe the communication protocols with provincial and municipal government and local police services.</li> <li>• Describe the maintenance program for all structures, facilities, equipment and systems critical to environmental protection.</li> <li>• Describe the approach to adaptive management.</li> <li>• Describe monitoring and reporting requirements.</li> </ul>
Blasting	<p>This component plan shall:</p> <ul style="list-style-type: none"> <li>• Define project and site-specific objectives.</li> <li>• List the applicable legislative and regulatory requirements. <ul style="list-style-type: none"> <li>○ All blasting activities in or near water are required to follow the “Guidelines for the use of Explosives In or Near Canadian Fisheries Waters” (DFO 1998) to reduce particle velocities and pressure changes created by underwater explosives that can result in fish injuries and mortality.</li> </ul> </li> <li>• Specify blasters name, company, copy of license, and statement of qualifications.</li> <li>• Describe the magazine type and locations for explosives and detonating caps (if on-site).</li> <li>• Describe typical rock type and geology structure (solid, layered, or fractured).</li> <li>• Specify the locations for blasting and volumes of materials to be removed.</li> <li>• For each location provide the following information: <ul style="list-style-type: none"> <li>○ Proposed limits for Peak Particle Velocity;</li> <li>○ Explosive type, product name and size, weight per unit, and density;</li> <li>○ Delay type, sequence, and delay;</li> <li>○ Use of non-electrical initiation systems for all blasting operations;</li> <li>○ Stemming material and tamping method;</li> </ul> </li> </ul>





EMP Component Plan	Key Requirements
	<ul style="list-style-type: none"> <li>○ Hole depth, diameter, and pattern;</li> <li>○ Explosive depth, distribution, and maximum charge and weight per delay;</li> <li>○ Number of holes per delay;</li> <li>○ Dates and hours of conducting blasting;</li> <li>○ Distance and orientation to nearest aboveground and underground structures;</li> <li>○ Measures for the Protection of aboveground and underground structures.</li> <li>● Describe the procedures for:               <ul style="list-style-type: none"> <li>○ Storing, handling, transporting, loading, and firing explosives;</li> <li>○ Fire prevention;</li> <li>○ Inspections after each blast;</li> <li>○ Misfires, fly rock, and noise prevention;</li> <li>○ Stray current accidental-detonation prevention;</li> <li>○ Signs and flagmen.</li> </ul> </li> <li>● Describe warning signals prior to each blast and notification prior to blasting.</li> <li>● Plans for disposal of waste blasting material. Procedures for monitoring and reporting on blasting operations.</li> <li>● Describe approach to construction site winterization and/or winter operations.</li> <li>● Describe the maintenance program for all structures, facilities, equipment and systems critical to environmental protection.</li> </ul>
Demolition	<p>This component plan shall:</p> <ul style="list-style-type: none"> <li>● Define project and site-specific objectives.</li> <li>● List the applicable legislative and regulatory requirements.</li> <li>● List and describe the buildings and structures to be demolished.</li> <li>● Provide time schedule for demolition works.</li> <li>● For each building and structure to be demolished provide the following information:               <ul style="list-style-type: none"> <li>○ Historical and/or heritage status;</li> <li>○ Presence / absence of Species at Risk (e.g., bats);</li> <li>○ Demolition waste types and volumes;</li> <li>○ Presence and volumes of hazardous materials;</li> </ul> </li> <li>● Describe the procedures for:               <ul style="list-style-type: none"> <li>○ Installation and removal of coffer dams;</li> <li>○ Noise abatement;</li> <li>○ Fugitive dust control;</li> <li>○ Treatment of discharge waters;</li> <li>○ Demolition waste management;</li> <li>○ Hazardous materials management.</li> </ul> </li> </ul>



EMP Component Plan	Key Requirements
	<ul style="list-style-type: none"> <li>• Describe the approach to adaptive management (e.g., contingency plan in case of any emergency situation).</li> <li>• Describe approach to construction site winterization and/or winter operations.</li> <li>• Provide cross-references to other component plans.</li> <li>• Describe monitoring and reporting requirements.</li> </ul>
Dewatering and Wastewater	<p>This component plan shall:</p> <ul style="list-style-type: none"> <li>• Define project and site-specific objectives.</li> <li>• List the applicable legislative and regulatory requirements. <ul style="list-style-type: none"> <li>○ Confirm the need for a Provincial permit to take water (PTTW) in accordance with the <i>Ontario Water Resources Act</i> (OWRA) and the Water Taking Regulation (O. Reg. 387/04) a regulation under the <i>Act</i>. Section 34 of the OWRA requires anyone taking more than a total of 50,000 litres of water in a day, with some exceptions, to obtain a Permit from a Director appointed by the Minister for the purposes of Section 34. The following water takings related to construction site dewatering and road construction may be eligible for registration in the Environmental Activity and Sector Registry (EASR): <ul style="list-style-type: none"> <li>▪ Surface water takings related to specific road construction purposes; and</li> <li>▪ Ground water and/or storm water takings of more than 50,000 L/day but less than 400,000 L/day for the purposes of construction site dewatering.</li> </ul> </li> </ul> </li> <li>• Describe the purpose of dewatering, sources and amount of water taking / removal required.</li> <li>• Describe the proposed dewatering and wastewater management methods, strategies, equipment and materials to be used, including any controls (that is, settling tank, turbidity curtain, etc.) and method of effluent discharge.</li> <li>• Provide at time schedule for dewatering works and activities.</li> <li>• Specify the anticipated dewatering flow rate and total dewatering duration.</li> <li>• Specify the anticipated wastewater volumes.</li> <li>• Specify water quality discharge criteria. <ul style="list-style-type: none"> <li>○ If dewatering conducted in a contaminated area, engineering specifications for dewatering effluent treatment and details for an analytical monitoring program to ensure that effluent will meet water quality discharge criteria.</li> <li>○ If wastewater is to be discharged, engineering specifications for treated effluent and details for an analytical monitoring program to ensure that effluent will meet water quality discharge criteria.</li> </ul> </li> <li>• Specify the point(s) of discharge.</li> <li>• Describe the maintenance program for all structures, facilities, equipment and systems critical to environmental protection.</li> <li>• Describe the approach to adaptive management (e.g., contingency plan in case of any emergency situation).</li> <li>• Describe approach to construction site winterization and/or winter operations.</li> </ul>



EMP Component Plan	Key Requirements
	<ul style="list-style-type: none"> <li>• Provide cross-references to other component plans.</li> <li>• Describe monitoring and reporting requirements.</li> </ul>
Surface Water, Erosion and Sediment Management	<p>This component plan shall:</p> <ul style="list-style-type: none"> <li>• Define project and site-specific objectives.</li> <li>• List the applicable legislative and regulatory requirements.</li> <li>• Describe the key sources of emissions or discharges to surface waters (e.g., equipment, works and activities) associated with the Project.</li> <li>• Identify the key point and non-point sources of contaminants (e.g., equipment, material storage areas or stockpiles, waste management facilities, vehicle and equipment maintenance facilities).</li> <li>• Identify need for alternative equipment, material storage or stockpile locations off-site.</li> <li>• Provide at time schedule for in-water works.</li> <li>• Describe the soil types found on-site and their constraints with respect to:             <ul style="list-style-type: none"> <li>○ surface water management;</li> <li>○ erosion control; and</li> <li>○ sediment control.</li> </ul> </li> <li>• Describe the surface water drainage patterns on the project site as well as coming on to the site and areas sensitive to erosion and sedimentation during each phase of the work.</li> <li>• List the key methods, strategies, structures, facilities, equipment and systems critical to:             <ul style="list-style-type: none"> <li>○ surface water management;</li> <li>○ erosion control; and</li> <li>○ sediment control.</li> </ul> </li> <li>• Tabulate applicable EIA commitments, terms and conditions of approval and relevant environmental standards and guidelines (Refer to <u>Part 2</u> of this ESG Document).</li> <li>• Describe approach to construction site winterization and/or winter operations for all structures, facilities, equipment and systems critical to:             <ul style="list-style-type: none"> <li>○ surface water management;</li> <li>○ erosion control; and</li> <li>○ sediment control.</li> </ul> </li> <li>• Describe the maintenance program for all structures, facilities, equipment and systems critical to environmental protection.</li> <li>• Describe the approach to adaptive management.</li> <li>• Describe monitoring and reporting requirements.</li> </ul>



EMP Component Plan	Key Requirements
Dredging and Sediment Removal	<p>This component plan shall:</p> <ul style="list-style-type: none"> <li>• Define project and site-specific objectives.</li> <li>• List the applicable legislative and regulatory requirements.</li> <li>• Identify the locations and volumes of dredged materials.</li> <li>• Identify locations for storage and/or disposal of dredged materials.</li> <li>• Provide time schedule for in-water works.</li> <li>• Identify the locations and provide a description of sensitive aquatic species and their habitat in vicinity of the dredging and sediment removal operations</li> <li>• List the key methods, strategies, structures, facilities, equipment and systems for dredging and sediment removal.</li> <li>• Tabulate applicable EIA commitments, terms and conditions of approval and relevant environmental standards and guidelines (Refer to <u>Part 2</u> of this ESG Document).</li> <li>• Describe approach to construction site winterization and/or winter operations.</li> <li>• Describe the maintenance program for all structures, facilities, equipment and systems critical to environmental protection.</li> <li>• Describe the approach to adaptive management.</li> <li>• Describe monitoring and reporting requirements.</li> <li>• Provide cross-references to other component plans.</li> </ul>
Vegetation Protection	<p>This component plan shall:</p> <ul style="list-style-type: none"> <li>• Define project and site-specific objectives.</li> <li>• List the applicable legislative and regulatory requirements.</li> <li>• Describe the key Project works and activities with the potential to adversely affect native vegetation.</li> <li>• Provide a time schedule for vegetation removal and/or ground disturbing activities.</li> <li>• Identify the locations and provide descriptions of areas to be disturbed and areas to be left undisturbed, including sensitive features (e.g., wetlands, woodlands, grasslands, valley lands, areas with Species at Risk).</li> <li>• List the key methods, strategies, structures, facilities, equipment and systems critical to vegetation protection.</li> <li>• Tabulate applicable EIA commitments, terms and conditions of approval and relevant environmental standards and guidelines (Refer to <u>Part 2</u> of this ESG Document).</li> <li>• Describe approach to construction site winterization and/or winter operations.</li> <li>• Describe the maintenance program for all structures, facilities, equipment and systems critical to environmental protection.</li> <li>• Describe the approach to adaptive management.</li> <li>• Describe monitoring and reporting requirements.</li> <li>• Provide cross-references to other component plans.</li> </ul>



EMP Component Plan	Key Requirements
Wildlife Protection	<p>This component plan shall:</p> <ul style="list-style-type: none"> <li>• Define project and site-specific objectives.</li> <li>• List the applicable legislative and regulatory requirements.</li> <li>• Describe the key Project works and activities with the potential to adversely affect wildlife.</li> <li>• Identify the locations and provide descriptions of any areas to be disturbed and areas to be left undisturbed, including sensitive features (e.g., Bat roosts, snake hibernacula, wildlife dens, bird nests, wildlife crossing areas, salt licks). Describe exclusionary measures (if required).</li> <li>• List the key methods, strategies, structures, facilities, equipment and systems critical to wildlife protection.</li> <li>• Tabulate applicable EIA commitments, terms and conditions of approval and relevant environmental standards and guidelines (Refer to <u>Part 2</u> of this ESG Document).</li> <li>• Describe the approach to nuisance wildlife control.</li> <li>• Describe approach to construction site winterization and/or winter operations.</li> <li>• Describe the maintenance program for all structures, facilities, equipment and systems critical to environmental protection.</li> <li>• Describe the approach to adaptive management.</li> <li>• Describe monitoring and reporting requirements.</li> <li>• Provide cross-references to other component plans.</li> </ul>
Aquatic Resources Management	<p>This component plan shall:</p> <ul style="list-style-type: none"> <li>• Define project and site-specific objectives.</li> <li>• List the applicable legislative and regulatory requirements.</li> <li>• Identify the locations and provide a description of in-water works.</li> <li>• Provide a time schedule for in-water works.</li> <li>• Identify the locations and provide a description of sensitive aquatic species and their habitat.</li> <li>• List the key methods, strategies, structures, facilities, equipment and systems critical to aquatic resources management.</li> <li>• Tabulate applicable EIA commitments, terms and conditions of approval and relevant environmental standards and guidelines (Refer to <u>Part 2</u> of this ESG Document).</li> <li>• Describe approach to construction site winterization and/or winter operations.</li> <li>• Describe the maintenance program for all structures, facilities, equipment and systems critical to environmental protection.</li> <li>• Describe the approach to adaptive management.</li> <li>• Describe monitoring and reporting requirements.</li> <li>• Provide cross-references to other component plans.</li> </ul>



EMP Component Plan	Key Requirements
Species at Risk Protection	<p>This component plan shall:</p> <ul style="list-style-type: none"> <li>• Define project and site-specific objectives.</li> <li>• List the applicable legislative and regulatory requirements.</li> <li>• Provide a time schedule for vegetation clearing and in-water works.</li> <li>• Identify Species at Risk to be protected.</li> <li>• Identify the locations and provide a description of Species at Risk critical habitat or other habitat areas to be protected.</li> <li>• List the key methods, strategies, structures, facilities, equipment and systems critical to wildlife and aquatic resources management.</li> <li>• Tabulate applicable EIA commitments, terms and conditions of approval and relevant environmental standards and guidelines (Refer to <u>Part 2</u> of this ESG Document).</li> <li>• Describe approach to construction site winterization and/or winter operations.</li> <li>• Describe the maintenance program for all structures, facilities, equipment and systems critical to environmental protection.</li> <li>• Describe the approach to adaptive management.</li> <li>• Describe monitoring and reporting requirements.</li> <li>• Provide cross-references to other component plans.</li> </ul>
Invasive Species Management	<p>This component plan shall:</p> <ul style="list-style-type: none"> <li>• Define project and site-specific objectives.</li> <li>• List the applicable legislative and regulatory requirements.</li> <li>• List the invasive species of concern on the Project site (including area immediately surrounding the Project site).</li> <li>• Tabulate applicable EIA commitments, terms and conditions of approval and relevant environmental standards and guidelines (Refer to <u>Part 2</u> of this ESG Document).</li> <li>• Describe the approach to adaptive management.</li> <li>• Describe monitoring and reporting requirements.</li> <li>• Provide cross-references to other component plans.</li> </ul>



EMP Component Plan	Key Requirements
Waste Management	<p>This component plan shall:</p> <ul style="list-style-type: none"> <li>• Define project and site-specific objectives.</li> <li>• List the applicable legislative and regulatory requirements.</li> <li>• Identify the locations and provide descriptions of waste storage, recycling and/or disposal facilities on-site.</li> <li>• Identify all off-site disposal facilities to be utilized and confirm their licensing status.</li> <li>• Describe site house-keeping procedures.</li> <li>• Describe the measures and procedures to minimize wildlife attraction to wastes.</li> <li>• Describe procedures for waste minimization, recycling, storage and disposal of hazardous and non-hazardous wastes, including wastes generated by:               <ul style="list-style-type: none"> <li>○ vegetation removal;</li> <li>○ earthworks (i.e., overburden stripping);</li> <li>○ dredging and sediment removal.</li> </ul> </li> <li>• Tabulate applicable EIA commitments, terms and conditions of approval and relevant environmental standards and guidelines (Refer to <u>Part 2</u> of this ESG Document).</li> </ul>
Hazardous Materials Management	<p>This component plan shall:</p> <ul style="list-style-type: none"> <li>• Define project and site-specific objectives.</li> <li>• List the applicable legislative and regulatory requirements.</li> <li>• Identify the locations and provide descriptions of hazardous materials storage facilities on-site.</li> <li>• Identify all off-site disposal facilities to be utilized and confirm their licensing status.</li> <li>• Provide an inventory of hazardous materials that will be used on-site.</li> <li>• Provide MSDS for all hazardous materials in use or to be stored on-site.</li> <li>• Provide an inventory and location of spill equipment to be stored on-site.</li> <li>• List the personnel trained to handle hazardous materials.</li> <li>• Tabulate applicable EIA commitments, terms and conditions of approval and relevant environmental standards and guidelines (Refer to <u>Part 2</u> of this ESG Document).</li> <li>• Describe approach to construction site winterization and/or winter operations.</li> <li>• Describe the maintenance program for all structures, facilities, equipment and systems critical to environmental protection.</li> <li>• Provide cross-references to other component plans.</li> </ul>



EMP Component Plan	Key Requirements
Fuel Management	<p>This component plan shall:</p> <ul style="list-style-type: none"> <li>• Define project and site-specific objectives.</li> <li>• List the applicable legislative and regulatory requirements.</li> <li>• Identify the locations and provide descriptions of facilities for fuel transfer and storage.</li> <li>• Describe the fuel handling, transfer and storage procedures.</li> <li>• Provide equipment refueling plans.</li> <li>• Provide an inventory and location of spill equipment to be stored on-site.</li> <li>• Tabulate applicable EIA commitments, terms and conditions of approval and relevant environmental standards and guidelines (Refer to <u>Part 2</u> of this ESG Document).</li> <li>• Describe approach to construction site winterization and/or winter operations.</li> <li>• Describe the maintenance program for all structures, facilities, equipment and systems critical to environmental protection.</li> <li>• Provide cross-references to other component plans.</li> </ul>
Spills Prevention and Emergency Response	<p>This component plan shall:</p> <ul style="list-style-type: none"> <li>• Define project and site-specific objectives.</li> <li>• List the applicable legislative and regulatory requirements.</li> <li>• Describe the on-site roles and responsibilities for spills and emergency response.</li> <li>• Tabulate applicable EIA commitments, terms and conditions of approval and relevant environmental standards and guidelines (Refer to <u>Part 2</u> of this ESG Document) with respect to spills prevention and emergency response procedures, including procedures for: <ul style="list-style-type: none"> <li>○ reporting a spill;</li> <li>○ stopping the spill if possible;</li> <li>○ containing the spill;</li> <li>○ protecting the area of the spill; and</li> <li>○ removing the material to an approved location for storage or disposal.</li> </ul> </li> <li>• Describe monitoring and reporting requirements.</li> <li>• Provide cross-references to other component plans.</li> </ul>





EMP Component Plan	Key Requirements
Dam / By-pass Channel Commissioning	<p>This component plan shall:</p> <ul style="list-style-type: none"> <li>• Define project and site-specific dam / by-pass channel commissioning objectives.</li> <li>• List the applicable legislative and regulatory requirements.</li> <li>• Describe the structures, systems or operations to be commissioned.</li> <li>• Tabulate applicable EIA commitments, terms and conditions of approval and relevant environmental standards and guidelines (Refer to <u>Part 2</u> of this ESG Document).</li> <li>• Describe pre-commissioning activities for each structure, system or operation (e.g., inspections, site/structure preparation, performance or operational testing).</li> <li>• Describe commissioning activities and schedules for each structure, system or operation.</li> <li>• Describe the approach to adaptive management (e.g., contingency plan in case of any emergency situation).</li> <li>• Describe monitoring and reporting requirements.</li> <li>• Provide cross-references to other component plans.</li> </ul>
Site Restoration	<p>This component plan shall:</p> <ul style="list-style-type: none"> <li>• List the applicable legislative and regulatory requirements.</li> <li>• Provide a time schedule for site restoration works.</li> <li>• Identify areas to be restored and their respective restoration objectives</li> <li>• Describe the restoration methods, vegetation to be used, etc.</li> <li>• Tabulate applicable EIA commitments, terms and conditions of approval and relevant environmental standards and guidelines (Refer to <u>Part 2</u> of this ESG Document).</li> <li>• Describe approach to construction site winterization and/or winter operations.</li> <li>• Describe the approach to adaptive management.</li> <li>• Describe monitoring and reporting requirements.</li> <li>• Provide cross-references to other component plans.</li> </ul>





## 6.0 INTRODUCTION TO ENVIRONMENTAL STANDARDS AND GUIDELINES (PART 2)

PCA undertakes, approves and/or oversees a wide variety of projects on Ontario Waterways. This document focuses on providing clear and practical guidance and setting PCA's expectations regarding how best to avoid or minimize adverse environmental effects of the following construction, maintenance and repair projects:

- Lock repairs and upgrades;
- Bridge repairs, upgrades and replacement;
- Earth dam repairs and upgrades;
- Retaining and approach wall repairs and replacements;
- Concrete dam repairs and upgrades;
- Concrete dam replacement (in-situ);
- Concrete dam replacement (rebuilds downstream or upstream); and
- Gravel roads.

This ESG Document may also provide guidance for other works and activities on Ontario Waterways.

The potential environmental effects of construction projects are vast and varied and inevitably very site-specific (i.e., dependent on the nature of the local environmental and socio-economic setting) and project-specific (i.e., dependent on the nature, scale, timing and design of the project).

Most of the major projects listed above involve a common set of project works and activities that result in potential environmental effects that are predictable and well understood. Table 5 identifies the typical project works and activities undertaken for these projects. [Appendix D](#) provides more information about each of these works and activities.

**Table 5: Typical Project Works and Activities on Ontario Waterways**

Project / Activity Type	Typical Project Works and Activities
Site Preparation (All Projects on Ontario Waterways)	<ul style="list-style-type: none"> <li>• Vegetation Removal (e.g., clearing, grubbing) and Protection</li> <li>• Earthworks (e.g., excavation, grading)</li> <li>• Installation and Removal of Erosion and Sediment Control and Water Quality Protection Measures</li> <li>• Dewatering</li> <li>• Installation and Removal of Cut-off Walls, Cofferdams or By-Pass Channels</li> <li>• Fish Passage, Salvage and Relocation</li> </ul>
Lock, Bridge, Retaining / Approach Wall or Concrete Dam Repair or Upgrade Project Construction	<ul style="list-style-type: none"> <li>• Demolition and/or Dismantling</li> <li>• Concrete Removal</li> <li>• Concrete Application and Re-construction</li> <li>• Repair, Salvage and/or Reinstallation of Ancillary Equipment</li> </ul>



Project / Activity Type	Typical Project Works and Activities
Earth Dam and Gravel Road Repair or Upgrade Project Construction	<ul style="list-style-type: none"> <li>• Transport and Stockpiling of Earth, Aggregate and/or Clean Fill</li> <li>• Designated Vegetation Removal</li> <li>• Earth, Aggregate and/or Clean fill Placement</li> </ul>
Concrete Dam Replacement Project Construction	<ul style="list-style-type: none"> <li>• Demolition and/or Dismantling</li> <li>• Blasting or Drilling</li> <li>• Concrete Pouring and Dam Reconstruction</li> <li>• Installation of Ancillary Equipment</li> </ul>
Site Restoration (All Projects on Ontario Waterways)	<ul style="list-style-type: none"> <li>• Backfilling</li> <li>• Site restoration (including Invasive species management)</li> </ul>

## 6.1 General Environmental Protection Procedures

General Environmental Protection Procedures provide direction and standards for many common elements of the design and construction activities for projects on Ontario Waterways. For these reasons, the standards and guidelines provided in this Section should be considered and where applicable, reflected in the EMPs for every project.

### 6.1.1 In-water Timing Windows and General Fish Protection Measures

The risk to fish habitat during construction is often reduced and controlled through the application of timing windows for in-water and near-water construction activities. Timing windows represent a period of opportunity for construction when the fish species known to occur in a particular waterbody are least vulnerable to potential impacts from construction based on their life history and habitat requirements.

All in-water and near-water construction or maintenance activities are to be conducted within the applicable in-water construction timing windows, as identified by MNR, to protect the resident fishery life functions. Timing windows are typically identified in the EIA documentation and general windows can be found on the following DFO and MNR website:

<http://www.dfo-mpo.gc.ca/pnw-ppe/timing-periodes/on-eng.html>

In addition, these windows are subject to change where species at risk or migratory fish corridors exist. These timing windows must be identified in the construction schedule and EMP.

For the most part, it is preferred that in-water activities be performed in the “dry”. For some activities (e.g., Tremie Concrete pours), this may not be possible. In such cases, additional mitigation measures and restrictions are typically required.

Working in the “dry” will require construction to occur behind water tight isolation barriers (coffer dam, cut-off walls, etc.) or within isolated dry work areas along active channels using dewatering and flow bypass methods. Specific environmental standards and guidelines are provided in Part 2 of this ESG Document.



Fish should be excluded from the work site to the extent possible before any work is conducted. Any fish stranded within the temporary in-water work zones should be salvaged and relocated using appropriate techniques by a Qualified Professional(s). A valid Historic Canals Regulations permit and/or Scientific Collector's Permit is required for fish salvage and relocation. Specific environmental standards and guidelines for fish exclusion, salvage and relocation are provided in Part 2 of this ESG Document.

### **6.1.2 Ground Disturbance Timing Windows**

The risk to resident and migratory breeding birds, their eggs and nests during construction is often reduced and controlled through the use of timing windows for vegetation clearing and construction activities. Timing windows represent a period of when the bird species are known to breed in the area based on their life history and habitat requirements. In addition, these windows are subject to change where species at risk or migratory bird's corridors exist. Unlike timing windows for the protection of fish, these timing windows represent a period that restricts or prohibits construction activities.

Removal of natural vegetation or structures such as buildings and dams that may be used for nesting should take place outside of the breeding bird window in order to avoid disturbance of migratory breeding birds protected by the *Migratory Birds Convention Act* (1994). If vegetation or structures are proposed to be removed during these restricted periods, then either exclusionary mitigation measures need to be employed before nesting season or the vegetation or structure will need to be surveyed for active breeding by a Qualified Professional(s) and will require exclusion from vegetation removal activities.

Timing windows are typically identified in the EIA documentation and general windows for C2 and C3 zones applicable to projects on Ontario Waterways can be found on the following Environment and Climate Change Canada website:

[http://www.ec.gc.ca/paom-itmb/default.asp?lang=En&n=4f39a78f-1#\\_fig01](http://www.ec.gc.ca/paom-itmb/default.asp?lang=En&n=4f39a78f-1#_fig01)

### **6.1.3 Surface Water, Erosion and Sediment Management Principles**

A detailed, site specific Surface Water, Erosion and Sediment Management Plan is required as part of an EMP for every project on Ontario Waterways. The primary objectives of this plan are to:

- Control and mitigate surface water from off-site and within the project area;
- Minimize the amount of erosion on-site;
- Control the amount of sedimentation occurring on-site;
- Minimize the deposition of deleterious substances to surface waters and minimize sediment input to surface waters.

As a secondary control measure if the first three are insufficient:

- Capture mobilized soil (sediment) as close to the source as possible; and
- Minimize the amount of surface water affected by sediment.

Specific environmental standards and guidelines relevant to Surface Water, Erosion and Sediment Management are provided in Part 2 of this ESG Document.



#### **6.1.4 Site Controls and Operational Constraints**

Site controls and operational constraints are important strategies for the protection of sensitive environments and habitats during construction. Such strategies often utilize avoidance techniques as a means of reducing or eliminating potential adverse effects. The following site controls and operational constraints are to be used as appropriate on all construction projects on Ontario Waterways:

- The construction access and work areas is to be confined to the extent required for the completion of project works and activities, and these areas are to be defined in the field using appropriately installed protective fencing or other suitable barriers prior to vegetation clearing or earthworks.
- Woody vegetation required for removal should be replaced with appropriate native species.
- Surface water runoff shall be managed throughout the site through stable ditches, drains, ponds, etc. Offsite water will be diverted before it enters the construction area, or separated to prevent contamination from construction activities (e.g., water infiltrating from cofferdams).
- Removal of riparian vegetation, particularly woody vegetation, will be kept to the minimum necessary for the project works. Every effort will be made to retain as much of the natural vegetation as reasonably possible to help ensure bank stability, control erosion and expedite the re-colonization of vegetative cover.
- Vegetation removal should be phased to construction activities (i.e., vegetation will only be removed when construction is occurring in that area).
- Only clean material that is free of particulate matter shall be placed in the water. This also includes material in sand bags or bulk bags.
- All activity will be controlled so as to prevent entry of any petroleum products, debris or other potential contaminants / deleterious substances, in addition to sediment as outlined above, to any waterbody.
- No storage, maintenance or refuelling of equipment will be conducted near any waterbody. Refuelling of equipment (e.g., pumps) and maintenance shall be conducted off slopes and away from water bodies on impermeable pads (drip tray) or buried liners to allow full containment of spills. Refuelling trucks are not to be within 30 meters of the waterbody. Some exceptions may apply and are described in Part 2 of this ESG Document.
- Any part of a vehicle and/or equipment entering the water shall be free of fluid leaks and externally degreased to prevent any deleterious substance from entering the water. Hydraulic fluids shall be vegetable based eco-friendly products.
- A Spill and Emergency Management Plan will be developed as part of the site-specific EMP. As outlined in Part 2 of this ESG document (see Refueling and Spill Management – ESG-13-C):
  - Any spill into water, onto ice or in a dewatered area must be reported immediately to PCA's Environmental Authority, the Departmental Representative and the Ontario Ministry of Environment and Climate Change's Spills Action Centre (SAC).



- Any spill on land must be reported immediately to PCA's Environmental Authority and the Departmental Representative. Any spill on land meeting the criteria set out in Ontario's *Environmental Protection Act*, O. Reg. 675/98 must be reported immediately to the Ontario Ministry of Environment and Climate Change's Spills Action Centre (SAC).

### **6.1.5 Materials Stockpiling and Storage**

Any temporarily stockpiled material, construction or related materials will be properly contained (perimeter control) in areas separated a minimum of 30 meters from any waterbody (if possible). If materials stockpiles are necessary within 30 meters of a waterbody, the Contractor shall describe relevant surface water protection, erosion and sediment control measures as part of its EMP. The EMP shall consider alternative stockpile locations on-site and off-site.

All excavated materials and debris shall be removed and deposited in an area above the high water mark of the shoreline and be contained behind properly installed and maintained sediment barriers or devices to prevent erosion and subsequent entry into the water body OR removed from the site, in accordance with all federal, municipal and provincial regulations.

## **6.2 Environmental Standards and Guidelines**

Part 2 of this ESG Document provide specific Environmental Standards and Guidelines for projects on Ontario Waterways. Three types of Environmental Standards and Guidelines are presented, where applicable.

*Best Practices* are guidance tools for project planners, design engineers, Contractors and PCA staff. These Best Practices establish the *minimum required standard of care* while allowing the designers and Contractors latitude to determine the "how" a project will be constructed. As noted, it is not the objective of this ESG Document to address or provide guidance regarding the design or engineering aspects of project development.

*Basic standards or "typicals"* are provided that indicate how to construct, install and maintain a particular device. These basic standards provide the minimum requirements to achieve a particular outcome, although they may be adopted for use in PCA design and tender documents, provided site conditions are appropriate.

Performance Criteria are provided for a selection of standards and guidelines where related *regulatory limits* exist. Where applicable to a given activity or project, PCA expects the performance criteria to be achieved through project design and use of appropriate mitigation and abatement techniques. Examples of performance criteria included in this document are those associate with blasting activities in and near fisheries waters and water quality criteria relating to turbidity.

Table 6 identifies those ESG contained in Part 2 that are applicable to the typical project works and activities undertaken for projects on Ontario Waterways. Appendix D provides more information about each of these works and activities.









## **PART 2:**

# **ENVIRONMENTAL STANDARDS AND GUIDELINES**



Category	Environmental Standards and Guidelines	Identifier
Pre- Construction Works and Activities	Erosion Control	<u>ESG-1-Pre</u>
	Sediment Control	<u>ESG-2-Pre</u>
	Soil Stripping, Grubbing and Stockpiling	<u>ESG-3-Pre</u>
	Tree Protection and Hording	<u>ESG-4-Pre</u>
	Vegetation Clearing and Protection	<u>ESG-5-Pre</u>
Construction Works and Activities	Abrasive Blasting	<u>ESG-1-C</u>
	Blasting	<u>ESG-2-C</u>
	Borehole and Rock Drilling	<u>ESG-3-C</u>
	Chipping and Cutting	<u>ESG-4-C</u>
	Concrete Pour Operations and Grouting	<u>ESG-5-C</u>
	Dredging and Sediment Removal	<u>ESG-6-C</u>
	Fish Exclusion, Salvage and Relocation	<u>ESG-7-C</u>
	Fugitive Dust Control During Construction	<u>ESG-8-C</u>
	Grinding and Welding	<u>ESG-9-C</u>
	Installation and Removal of Cofferdams and Isolation Structure	<u>ESG-10-C</u>
	Invasive Species Management	<u>ESG-11-C</u>
	Pile Driving	<u>ESG-12-C</u>
	Refueling and Spill Management	<u>ESG-13-C</u>
	Treatment of Discharge Waters	<u>ESG-14-C</u>
	Use and Maintenance of Heavy Equipment	<u>ESG-15-C</u>
	Vehicle and Equipment Washing and Cleaning	<u>ESG-16-C</u>
	Wildlife and Species at Risk Protection During Construction	<u>ESG-17-C</u>
	Winter Weather Stabilization and Operations	<u>ESG-18-C</u>
Post-Construction Works and Activities	Revegetation	<u>ESG-1-Post</u>



# Erosion Control (ESG-1-Pre)

---

## Application to Ontario Waterways' Projects

Land based construction involving activities such as vegetation removal, topsoil stripping, excavation or soil stockpiling create the potential for soil erosion that can affect surface water quality or deposit fine sediment into adjacent wetlands and waterbodies. Protecting exposed soil from erosion and containing run-off to prevent off-site migration is a critical component of construction, maintenance and repair projects on Ontario Waterways. For this reason, industry accepted standard erosion control devices are extensively used on both major and small scale land based construction projects.

## Description of Activity

Erosion controls for construction sites are intended to deal only with rainfall / snowmelt water within the site, and not for handling water from off the construction site. Construction site erosion control practices generally involve preserving existing vegetation, staged removal when possible, or stabilizing disturbed areas with exposed soils with temporary covers comprised of seeded vegetation or sod. Methods depend on the duration of soil exposure, the phase of the project, and/or the season in which the erosion control methods are being applied. The selection of appropriate erosion controls involves identifying the factors that influence the type and severity of potential erosion. Factors that influence the type of erosion control method to be used include climate, soil properties, soil cover, land management and topography.

- |                         |  |
|-------------------------|--|
| Climate / Precipitation | <ul style="list-style-type: none"><li>• Duration and intensity of rainfall, snowfall and snowmelt regulates the amount of soil detachment and subsequent loss from the land. The greater or more intense the rainfall, snowfall and subsequent snowmelt, the greater the potential for erosion.</li></ul>  |
| Soil Properties         | <ul style="list-style-type: none"><li>• Soil texture (the proportion of clay, silt, and sand particles in a soil) influences infiltration of water as well as the ease of detachment. For example, sand and silt particles are most easily detached because they are small and do not easily form aggregates and are more easily eroded. In contrast, more calcareous soils tend to erode more easily on steep slopes, while clay soils have low potential to erode on steep slopes. However, sandy soils will tend to settle in water more quickly than silts and clays. For this reason, erosion controls are geared towards managing the finer sized particles that have the greatest potential to result in turbid waters.</li></ul> |
| Soil Cover              | <ul style="list-style-type: none"><li>• Bare soil is exposed to the full erosive power of rain, snow and runoff / snowmelt water. Vegetative canopy helps stabilize soil and controls runoff. The vegetative canopy intercepts rain and reduces its erosive energy. Dense canopies that cover much of the soil surface intercept a large proportion of the rainfall. Soil covers comprised of seeded vegetation or sod also minimize the contact of runoff / snowmelt water with soil. Here, the roots of vegetation, such as grass, bind soil particles together to resist erosion.</li></ul>   |
| Land Management         | <ul style="list-style-type: none"><li>• Clearing, grading, and other activities disturb the soil surface, remove existing vegetation, and alter topography, thereby increasing erosion risk. Massive land clearing done by large construction equipment pulverizes the soil and clears all vegetation. This mechanical disturbance exposes the soil directly to the impact of rainfall energy. Highly disturbed soils have also lost much of the organic matter that glues them together. Also, the rate of water infiltration is usually decreased and water that does not soak into the soil runs off carrying sediment.</li></ul>   |



Topography /  
Slope Length

- The degree of steepness (percent slope), as well as the slope length, is important. Steep slopes have high runoff water velocity. This increases its erosive energy (i.e., the erosive energy of runoff is a function of runoff velocity and volume). When the slope is longer (length), surface area for water collection also increases and therefore increases the run-off volume.

Erosion controls require proper selection, installation and regular inspection and maintenance. Along with non-structural methods such as minimizing the amount of exposed soil at a site, erosion controls generally either dissipate energy or divert surface run-off.

### *Environmental Standards and Guidelines*

Site-specific erosion controls (as part of an overall Surface Water Management, Erosion and Sediment Control Plan, shall be developed by a Qualified Professional(s) and included in the Contractor's EMP for review and acceptance by PCA. Timing and scheduling, staging, minimizing the amount of exposed soil, surface stabilization and directing surface water runoff away from exposed soil and managing water within the work zone must be considered in developing site-specific plans.

### *Timing and Scheduling*

Developing a schedule and planning the project are the very first steps in developing an effective soil erosion control program. Erosion control strategies shall be undertaken and specific erosion control devices shall be installed prior to the undertaking of any ground disturbing activities and prior to winter operations.

### *Staging and Sequencing*

Construction staging and sequencing shall be planned to minimize the duration of time that soils are disturbed and exposed to erosive forces prior to and following construction. The best form of erosion control is not to disturb soils unless absolutely required and only immediately prior to the required work. Project staging must be described in the Construction Plan of the site-specific EMP. Best practices in construction staging (VOI, 2005) are:

- Dividing the overall project site into a series of smaller work areas and implement construction progressively rather than simultaneously in all work areas. The erosion potential within each work area should be determined (see below) to assist in selecting appropriate erosion controls;
- Erecting barriers to restrict construction activities to within the identified work boundaries; and
- Maintaining existing vegetation or providing temporary vegetative cover in areas that are inactive.

### *Minimize Disturbance and Buffer Strip*

The primary objective of buffer strips is to protect the riparian zone along wetlands and waterbodies, which is critical to the maintenance of a healthy aquatic environment. Where practical, the retention of vegetated buffer strips should be planned for works adjacent to all waterbodies and wetlands.

### *Surface Stabilization*

Surface stabilization techniques must be considered and, if appropriate, described in the site-specific EMP. Surface stabilization is a process that protects exposed surface soils from wind and water erosion. Techniques can vary from roughening the surface soil, benching and contour furrows, applying an organic layer or covering, applying a tackifier, seeding or using soil erosion control blankets. In some cases using



one or more of these techniques may be required. Techniques should be chosen based on duration of treatment (i.e., short term vs permanent).

#### Directing Surface Water Runoff Away From Exposed Soil

Surface water diversion techniques must be considered and, if appropriate, described in the site-specific EMP. Diversion structures redirect potentially erosive flow away from or around exposed soils and towards a well vegetated area for runoff deposition or into a treatment facility. Reducing the amount of water in the work zone will decrease effort in treating turbid and potentially contaminated water. These techniques include: slope drains, diversion berms, conveyance channels or diversion dykes. These techniques are often used in conjunction with surface stabilization on steep slopes and erosion prone soils.

#### Determining Erosion Potential

As discussed above, several factors can influence the erosion potential of soils within a work area. The risk of soil erosion is directly related to the slope and the soil properties within the work area. Runoff pathways, slope patterns and valley features will also influence the likelihood of runoff / snowmelt waters causing erosion. It is important to consider all potential sources of runoff, including snowmelt waters, groundwater seeps, etc.

- Steep slopes with a grade greater than 33% and consisting of sandy and light silty soils are at a very high risk of erosion.
- Moderate slopes with a grade between 17% and 33% with sandy and light silty soils or medium and calcareous soils have a high or moderate risk of erosion, respectively.
- Gentle slopes with a grade between 10% and 17% have a low to moderate risk of erosion for medium and calcareous soils; with clay till or heavy soils having a low risk of erosion on most slope.

As noted above, if the finer sediments such as clays and silts get into suspension in a waterbody, they do not settle out or deposit as quickly as more coarse materials such as sands. Suspension is when material made up of very fine particles such as clay and silt are lifted as the result of turbulence and transported by flowing water. The faster flowing and more turbulent the water, the more suspended the material becomes

#### Selecting Erosion Control Measures

The selection of erosion control measures shall considered a variety of factors, including: the size of the work area, its erosion potential (see above), the extent of vegetation cover, degree of soil compaction, and the duration of treatment.

Areas with higher risk of erosion typically require multiple and more robust control measures. More robust measures are those that require the construction of facilities and structures such as diversion dikes, channels, swales and slope drains. The following provides suggested erosion control measures/devices and associated best practices.

#### Slope Texturing and Surface Roughening

Slope texturing, surface roughening uses tracked equipment or agricultural implements to leave the ground surface in a rough textured condition to reduce soil erosion or to prepare a seed bed. The measure reduces runoff velocity and increase infiltration. Best practices and limitations (VOI, 2005) include:



- Leaving slopes in rough condition when building fills, excavating cuts or reapplying topsoil.
- All slope texturing practices must be applied on-contour (i.e., across the slope).
- Slope texturing and surface roughening are not practical on short slopes or slopes steeper than 2H:1V.
- Roughness elements should be randomly sized and spaced, between 50 mm to 100 mm in height.
- When using tracked equipment or agricultural implements to roughen surfaces, limit the activity to one or two passes to minimize soil compaction.
- Narrow, gently (~ 1%) in-sloping soil benches should have an elevation change of <8 m. Design of benches should be undertaken by a Qualified Professional(s).
- Seeding should occur immediately following slope texturing or roughening.

### Mulching and Compost

Mulching is the application of a protective layer of organics such as straw, woody fibres or other suitable organic material to temporarily stabilize bare and disturbed soil. Mulch can be applied most times of the year. Trees and shrubs removed from the construction site during clearing activities can be shredded and used as mulch on newly exposed surfaces. The application of mulch results in protection of surface soil from raindrop impact, increased surface water infiltration, conservation of moisture, prevention of soil compaction or crusting, and decreased surface water runoff. Mulching also fosters growth of vegetation by protecting the seeds from predators, reducing evaporation, and insulating the soil.

Hydromulching is a soil stabilization technique where a fibre mulch is applied to disturbed and exposed soil surfaces and is primarily intended to protect the soil surface from raindrop impact erosion. The fibre which may be wood fibre, straw, or compost is applied to the soil surface hydraulically in a slurry consisting of the fibre, water and a binding agent. Hydromulch is applied using a mechanical hydro seeder and can also be used as a tackifier for straw mulch or in combination with seeding. When applied correctly and when using the proper mulches and tackifiers, the hydromulch can be effective against soil erosion for over a year.

A compost blanket is a layer of compost applied to surface soil to prevent erosion, especially rills and gullies used for temporary or permanent erosion control and slope stabilization and vegetation establishment. Compost erosion control blankets act similarly to mulch products but provide organic nutrients that promote vegetation growth, even in areas where germination, moisture management and irrigation could be challenging. For these reasons, a compost blanket can be more effective at vegetation establishment, weed suppression and erosion control than an Erosion Control Blanket or hydroseeding. Compost blankets are typically applied to slopes with pneumatic blower trucks which make them easy to apply to slopes or hard to reach areas.

Best practices and limitations (VOI, 2005) include:

- Organic mulches can be applied to a range of slope gradients up to 1.5H:1V and most soil types.
- Should not be used as a stand-alone or long term (>1 year) erosion control measure but should be combined with other erosion control measures for optimal performance.
- Some mulches can inhibit or prevent vegetative growth, while others promote vegetation growth and establishment.
- Straw, woodchips, woodfibre and compost materials are preferred. Use of recycled paper (cellulose) requires review and acceptance by PCA prior to application.
- Mulches must be applied as recommended (see below) to be effective as an erosion control measure:



- Straw
  - Straw is applied evenly in a 20 – 40 mm thick layer in *areas that will be seeded*, at a bulk application rate of 3,300 – 4,500 kg/ha over 80 – 90% of the soil surface. Straw should be anchored through crimping or tackifiers.
  - Straw is applied evenly in a 40 - 60 mm thick layer in *areas that will not be seeded*, at a bulk application rate of 4,500 – 6,700 kg/ha over more than 90% of the soil surface. Straw should be anchored through crimping or tackifiers.
- Woodchips
  - Locally generated woodchips are applied evenly in a 50 – 75 mm layer, at a rate of 13,500 kg/ha mixed in a 30% woodchip to 70% soil ratio.
- Woodfibre
  - Woodfibre is applied hydraulically at a rate of 1,200 - 1,500 kg/ha mixed in a 20 kg of wood fibre to 500 litres of water (or in accordance with manufacturer’s specifications)
  - Effective as a temporary erosion control measure on slopes less than 4H:1V.
- Compost
  - Compost is applied onto roughened or decompacted soils on slopes as steep as 1H:1V and 1 – 2 m back from slope crest
  - Compost blanket thickness varies with slope and anticipated rainfall over a 24 hour period.

Slope (H:V)	Recommended Compost Erosion Blanket Thickness (mm)		
	Rainfall = 16.5 mm	Rainfall = 50 mm	Rainfall = 100 mm
<4:1	12.5 to 50	25 to 50	50
4:1 to 3:1	12.5 to 50	25 to 50	50
3:1 to 2:1	25 to 50	25 to 50	25 to 50

Seeding, Hydroseeding and Sodding

Seeding is an important step in revegetating disturbed construction sites and will help reduce soil erosion issues. There are two approaches to seeding with the first being temporary seeding for short term exposed soils and long term seeding associated site revegetation. Seeding alone is not an erosion control method unless an erosion control blanket or Rolled Erosion Control Product is applied over top and secured in place.

Hydroseeding is the use of water as a medium to spray and spread seeds onto the seedbed. Hydroseeding is not an erosion control method unless a bonded fibre matrix is applied or an erosion control blanket or Rolled Erosion Control Product is applied over top and secured in place. Sodding offers a quick and relatively inexpensive method of establishing vegetation. Both of these techniques require frequent watering until roots become established. Best practices and limitations (VOI, 2005) include:

- Site soils must be prepared, decompacted (>300 mm) and amended for seeding and/or a suitable growth medium (see recommended topsoil thicknesses in Revegetation (ESG-1-Post)) be applied to support plant germination and growth. Soil pH should be >6.5. The type and amount of soil amendment (i.e., the fertilizer mix) shall be identified in the EMP.
- Dry seeding (i.e., by hand, rotary seeders, cyclone seeders, drill seeding) is preferred for small areas and/or longer term applications associated with site revegetation following construction.
- Hydroseeding is most appropriate for large areas where seedbed preparation is impractical and/or longer term applications associated with site revegetation following construction.





- Sodding is to be used for final landscaping purposes or for erosion control in very small areas (e.g., surrounding temporary buildings, along drainage ditches, etc.).
- Regular inspection and maintenance (once per week) is essential for successful seeding. Watering and multiple seeding / re-sodding operations may be required.
- Careful consideration must be given to timing, seed mixtures and application rates.
  - Timing
    - Seed areas immediately once the area is brought to final contour or would be left undisturbed for more than 30 days.
    - Seeding should occur on same day that the soil was prepared for seeding and preferably during spring or summer. Fall seeding is recommend for construction site winterization.
  - Seed Mixtures
    - Only seed mixtures native to Ontario, identified in the EMP and accepted by PCA shall be used.
    - Species will be appropriate for site conditions and habitat. Invasive species will not be used. A Qualified Professional(s) shall be consulted to assist with selection of seed mixture.
  - Application Rates
    - Apply seed mixes at recommended application rates (see Revegetation (ESG-1-Post)).
    - If hydroseeding is combined with hydraulic mulching in a single operation, seed application rates are increased by 25% – 30%.

#### Soil Binders / Tackifiers

Tackifiers are binding agents that act as a "glue" to hold soil particles together and are used to reduce soil erosion on loose dry soil. Tackifiers are also used to anchor straw mulch to the soil surface. Tackifiers can also protect seedbeds by holding the product to the soil surface and preventing movement. Tackifiers are available in both organic and synthetic varieties for specific applications. Commonly used organic products are guar, psyllium and starch. Synthetic products include various polymeric compounds and resins. Chloride compounds are primarily used for unpaved roadway stabilization. Best practices and limitations include:

- The purpose, type(s) and amount of tackifiers to be used shall be identified in the EMP and accepted by PCA.
- Petroleum based tackifiers are prohibited.
- Organic tackifiers are preferred to synthetic varieties. Application of soil stabilizer is intended to be conducted with conventional hydraulic seeding equipment. Soil stabilizer may also be placed by dry spreading. Application rates for common organic tackifiers are:
  - Guar is a non-toxic and biodegradable product that should be stored, mixed and applied according to manufacturer's specification, but typically between 45 kg/ha for flat areas and up to 80 kg/ha for 1H:1V slopes.
  - Psyllium is a biodegradable finely ground coating of plantago seeds, and is applied as a dry powder or in a wet slurry to the surface of the soil. It should be stored, mixed and applied according to manufacturer's specification, but typically between 90 to 225 kg/ha. Note that this product requires a 12 to 18 hour drying time prior to a precipitation event.
  - Starch is biodegradable, cold water soluble granular cornstarch mixed with water and typically applied at the rate of 168 kg/ha requiring a drying time of between 9 to 12 hours.



- Additional important considerations for soil binders and tackifiers include the following.
  - They are easily damaged by traffic and lose their effectiveness more rapidly than organic mulches.
  - They decompose with varying times, some within 60 to 90 days.
  - Material safety data sheets for all synthetic products should be provided to verify that products are free of toxics and to ensure proper handling.
  - When using soil binders and tackifiers, seed must be sown separately from the time when the soil binder or tackifier is applied.
  - When soil binders or tackifiers are used on permanent slopes, an approved mulch should be applied as well to protect and facilitate germination of new seed.

#### Rolled Erosion Control Products (RECP) and Fibre Rolls

Rolled Erosion Control Products (RECP) are soil stabilization devices consisting of prefabricate layers of material that is laid on the soil to protect disturbed surface soil from raindrop impact erosion. They are carpet-like mats, installed and anchored to properly prepared soil surfaces along slopes or to unvegetated conveyance systems. RECPs also protect seed sites and provide protection and cover for vegetation to become established.

Fibre rolls are long tubes that act as barriers to sediment, allowing water to flow through. Fibre rolls help control erosion by intercepting sheet flow and creating ponding of runoff water and promoting suspended sediment to settle out of runoff water. They are installed across slopes to slow or stop the flow of surface runoff and installed across shallow ditches and drains to reduce the velocity of flowing water.

Best practices and limitations (VOI, 2005) include:

- The type(s) and proposed application of RECPs and Fibre Rolls shall be identified in the EMP and accepted by PCA.
- RECPs and Fibre Rolls composed of plastics are prohibited (e.g., plastic netting).
- Only open weave, biodegradable products are to be used:
  - Erosion control blankets or organic fibre rolls composed of processed natural fibres (e.g., cereal, straw, coir or coconut husk, wood strands);
  - Open weave textile composed of natural fibres; and
  - Mulch control netting composed of natural fibres.
- Appropriate RECPs shall be used depending on application (i.e., slope, ditch/channel and soil conditions).
- Disturbed soils must be prepared and seeded prior to RECP installation. Do no seed or reseed over a RECP.
- RECPs shall be installed according to manufacturer's specifications and as illustrated in the Figures below (VOI, 2014). RECP fasteners such as wooden or biodegradable stakes are preferred to wire stables, metal or plastic pins.
- RECPs shall be inspected weekly and following each rainfall or snowmelt event. Displaced or damaged RECPs shall be replaced. Rills that develop under the RECP must be filled with soil prior to replacement.



### Temporary Diversion Ditches/Berms/Swales and Slope Drains

Diversion structures redirect potentially erosive flow away from or around exposed soils and towards a well vegetated area for runoff deposition. Diversion ditches, berms and swales are temporary barriers placed at the base of a slope or along the perimeter of construction areas to slow down the speed of runoff and reduce erosion potential. They are typically parabolic or trapezoidal in shape often constructed in association with dykes. Slope drains typically consist of flexible pipe that conveys water runoff down a hillside from one source toward a protected area or receiving waterbody. Temporary slope drains can also be constructed as open top drains or with plastic sheeting and geotextile fabric. These techniques are often used in conjunction with surface stabilization on steep slopes and erosion prone soils. Best practices and limitations (VOI, 2005) include:

- Diversion Ditches, Berms and Swales
  - The location and design of diversion ditches, berms and swales shall be identified in the EMP and accepted by PCA
  - Diversion ditches, berms and swales shall be designed by a Qualified Professional(s).
  - Temporary diversion ditches, berms and swales are not intended for diversion of a natural watercourse;
  - Individual structures are limited to small catchments of less than 2 ha.
  - Diversion ditches can be lined or armoured with a filter layer and rock. Berms and swales shall be stabilized immediately after construction.
  - Diversion ditches, berms and swales shall be installed as per design but generally as illustrated in the Figures below (VOI, 2014).
  
- Slope Drains
  - The location and design of slope drains shall be identified in the EMP and accepted by PCA.
  - Individual structures are limited to small catchments of less than 2 ha. A 2 ha catchment area would require a pipe diameter of approximately 760 mm. Smaller catchments require smaller sized pipes. If the catchment areas are greater than 2 ha, additional slope drains shall be installed.
  - Diversion ditches, berms and swales shall be installed as per design but generally as illustrated in the Figures below (VOI, 2014).

### Inspection and Maintenance of Erosion Controls

- An inspection program (e.g., performance monitoring) that evaluates the integrity, functionality and effectiveness of erosion control methods shall be described in the EMP and accepted by PCA.
- Inspection of erosion controls within the construction area shall be undertaken weekly and following each rainfall or snowmelt event, and repaired as required. The inspections are intended to:
  - confirm erosion control methods and devices have been installed according to the contract plans and correctly according to installation standards;
  - confirm erosions control methods and devices are maintained and functioning as intended; and
  - identify deficiencies of selected measures based on observations of terrain, soils, or construction progress.



### *Related Environmental Standards and Guidelines*

- General Environmental Protection Procedures
- Sediment Control (ESG-2-Pre)
- Soil Stripping, Grubbing and Stockpiling (ESG-3-Pre)
- Vegetation Clearing and Protection (ESG-5-Pre)

### *Related EMP Component Plans*

- Dust and Air Quality Management
- Blasting
- Demolition
- Site Dewatering and Wastewater Management
- Surface Water Management, Erosion and Sediment Control
- Dredging and Sediment Removal
- Vegetation Protection
- Wildlife Protection and Management
- Aquatic Resources Management
- Invasive Species Management
- Spills Prevention and Emergency Response
- Dam and/or Bypass Channel Commissioning
- Site Restoration

### *Other Design and Environmental Considerations*

- Timing of works should avoid seasonally high rainfall and snowmelt periods.
- Timing windows for in-water works shall be respected.

### *References*

CISEC, 2014. Certified Inspector and Sediment and Erosion Control Training Manual. Revised Edition V6. 9520 Pine valley Drive, Woodbridge Ontario, Canada.

Erosion and Sediment Control Guidelines for Urban Construction, 2006. Greater Golden Horseshoe Area Conservation Authorities.

Minnesota Stormwater Manual. Erosion Prevention Practices - Tackifiers and Soil stabilizers. Available at: [https://stormwater.pca.state.mn.us/index.php?title=Erosion\\_prevention\\_practices\\_-\\_tackifiers\\_and\\_soil\\_stabilizers](https://stormwater.pca.state.mn.us/index.php?title=Erosion_prevention_practices_-_tackifiers_and_soil_stabilizers)

Plant and Soil Sciences eLibrary, 2017. Erosion. Available online: <http://passel.unl.edu/pages/informationmodule.php?idinformationmodule=1086025423&topicorder=1&maxto=20&mint=1>

VOI Training Group, 2005. Erosion and Sediment Control – Participant’s Manual. Developed by Van Osch Innovations Ltd., 130 Columbia Street, Nanaimo, British Columbia, Canada.

VOI Training Group, 2014. Environmental Field Procedures for Works in and About Water. Developed by Van Osch Innovations Ltd., 130 Columbia Street, Nanaimo, British Columbia, Canada.

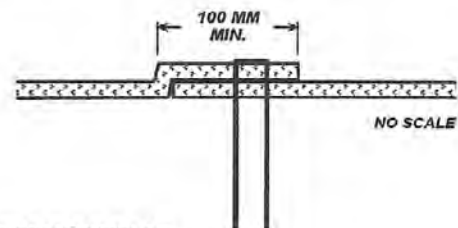
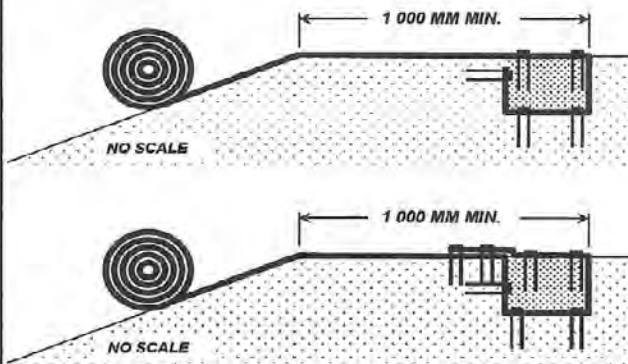
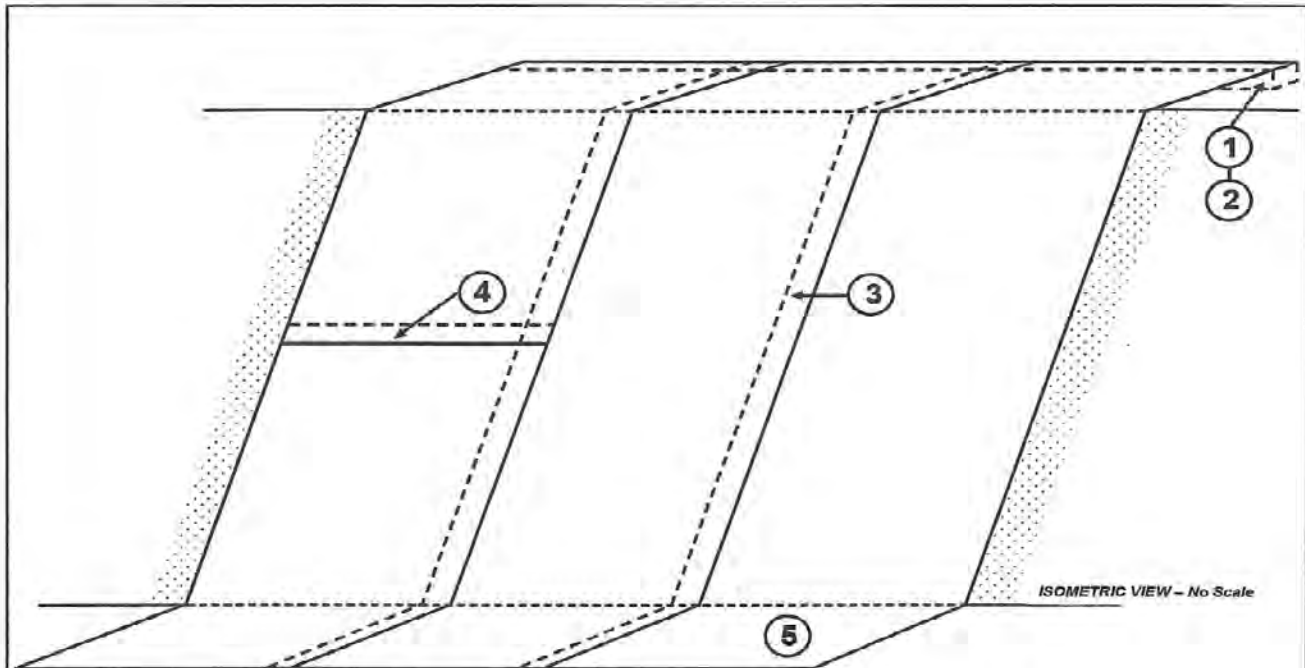

- ③ SIDE SEAM OVERLAP**
1. ANCHOUR THROUGH BOTH RECPS
  2. ANCHOURS 150 MM O.C.

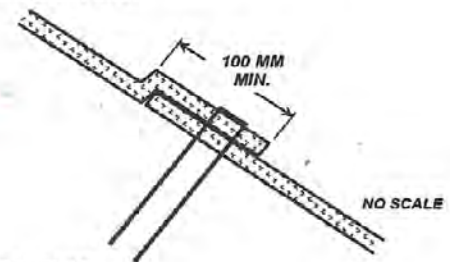

- ④ END ROLL OVERLAP**
1. ANCHOUR THROUGH BOTH RECPS
  2. ANCHOURS 150 MM O.C.

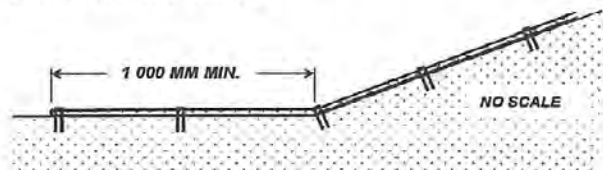

- ⑤ BOTTOM OF SLOPE TERMINATION**
1. ANCHOURS 150 MM O.C. AT TERMINAL END OF RECP
  2. ANCHOURS 150 MM O.C. AT SLOPE TRANSITION

**① & ② TOP SLOPE ANCHOUR TRENCH**

1. EXCAVATE 300 MM X 200 MM TRENCH
2. LAY RECP THROUGH TRENCH
3. STAGGERED ANCHOURS 300 MM O.C. IN TRENCH
4. BACKFILL & LIGHTLY COMPACT FILL
5. SEED / SOIL APPLY AMENDMENTS
6. STAGGERED ANCHOURS 300 MM O.C. AT SURFACE

**NOTES:**

1. PREPARED SOIL SURFACE SHOULD BE RELATIVELY SMOOTH (NO SHARP DEPRESSIONS OR HUMMOCKS).
2. REMOVE ALL MATERIALS THAT MAY PREVENT RECP CONTACT WITH THE SOIL SURFACE.
3. APPLY TOPSOIL IF SPECIFIED OR AVAILABLE.
4. SEED AREA WITH SPECIFIED SEED MIXTURE AT SPECIFIED SEEDING RATE. APPLY SOIL AMENDMENTS, IF PRESCRIBED.
5. INSTALL RECP WORKING DOWNSLOPE. ENSURE RECP IS NOT STRETCHED OR UNDER TENSION. RECP MUST CONFORM TO SOIL SURFACE.
6. DO NOT WALK ON RECP DURING OR FOLLOWING INSTALLATION.
7. RECP SHOULD NOT BE INSTALLED ACROSS SLOPE.
8. INSTALL SUFFICIENT ANCHOURS TO MAINTAIN RECP CONTACT WITH SOIL AND PREVENT RECP DISPLACEMENT BY WATER / WIND.
9. ANCHOR DENSITY SHOULD BE DETERMINED BY SITE SPECIFIC CONDITIONS. CONSIDER GENERIC ANCHOR DENSITY / SPACING RECOMMENDATIONS TO BE MINIMUM ANCHOURING REQUIREMENT.
10. CONSULT QUALIFIED PROFESSIONAL REGARDING SITE-SPECIFIC RECP SELECTION AND INSTALLATION.

**ROLLED EROSION CONTROL PRODUCT  
OPEN SLOPE APPLICATIONS**

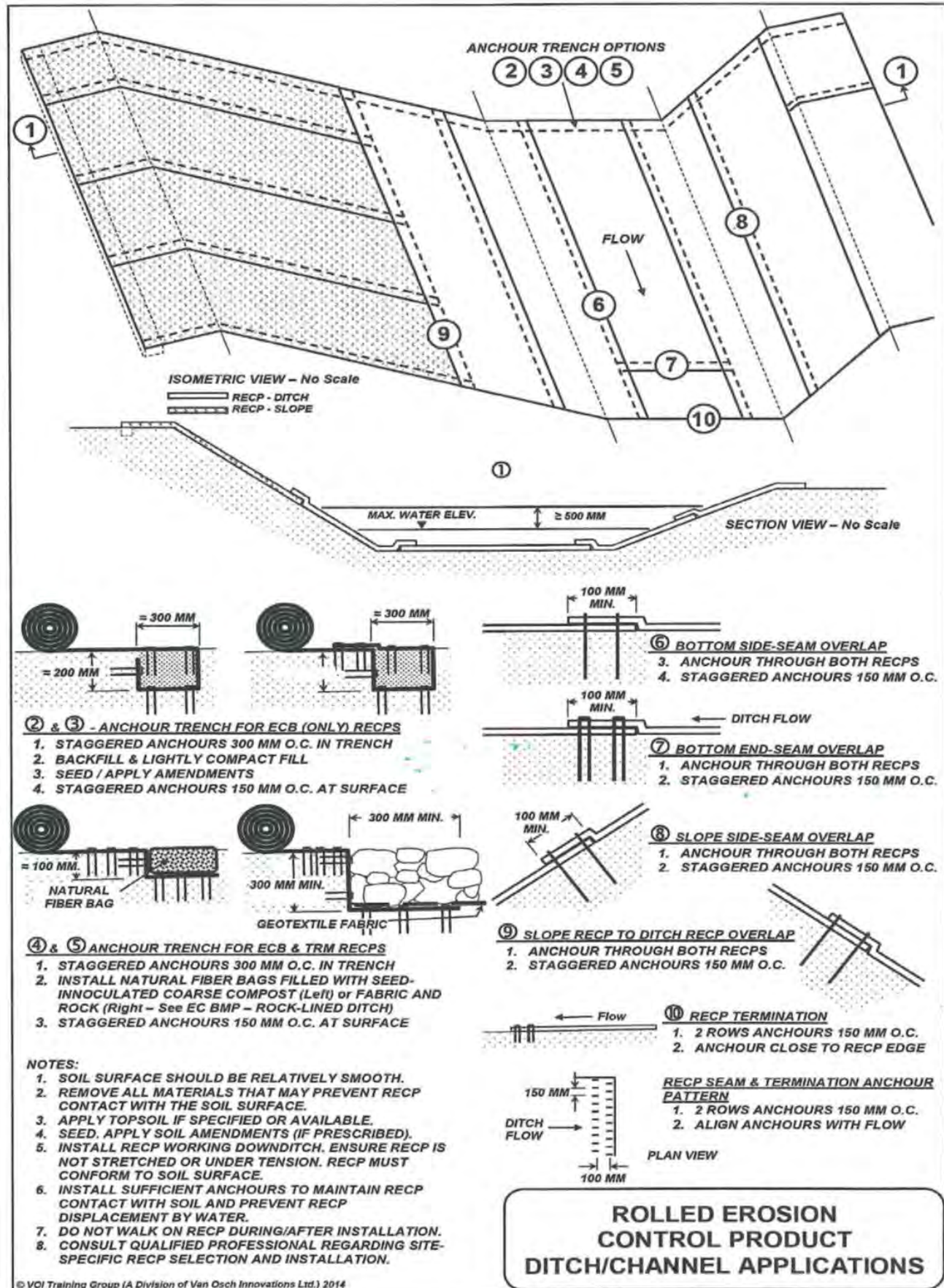

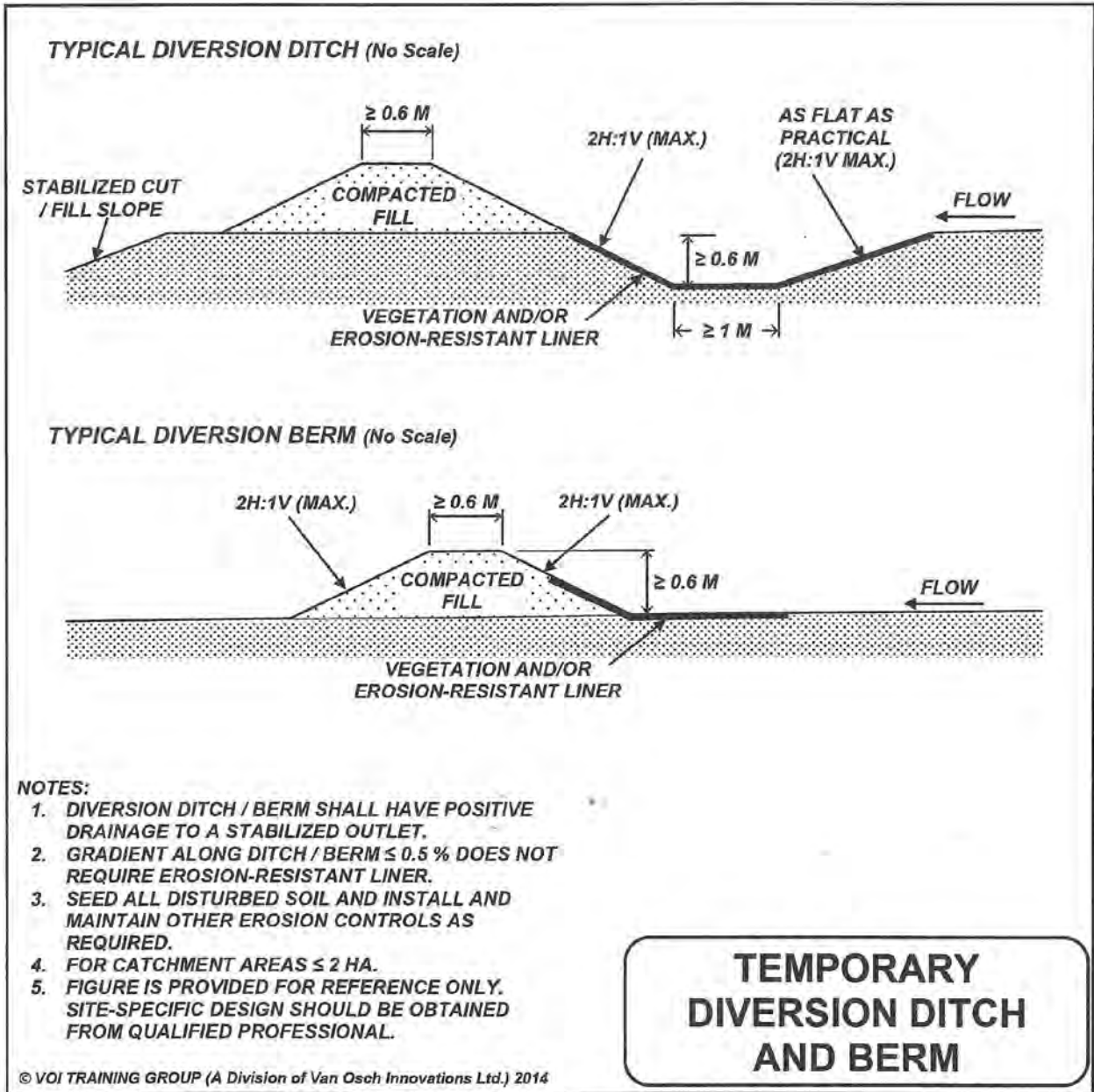

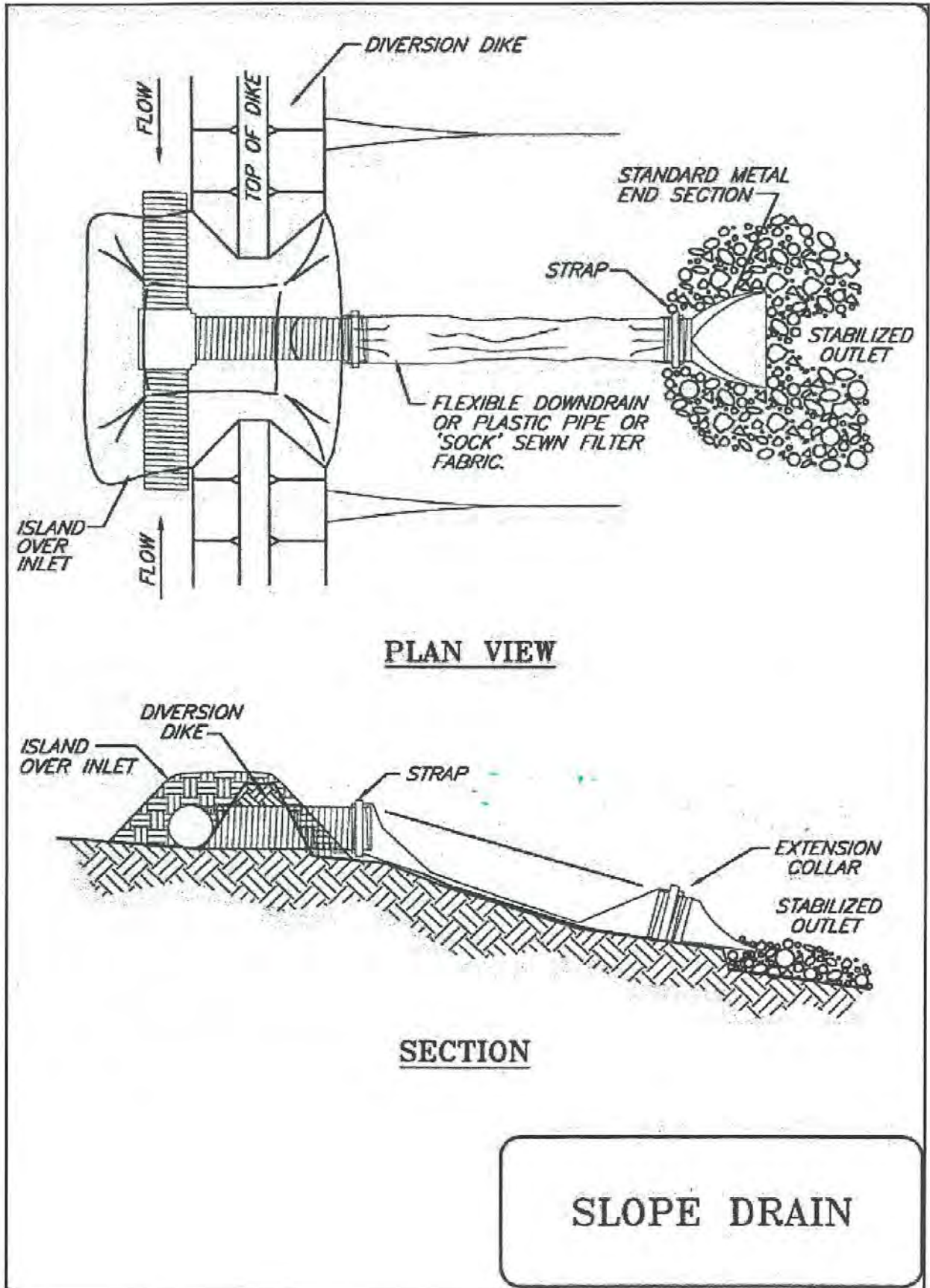



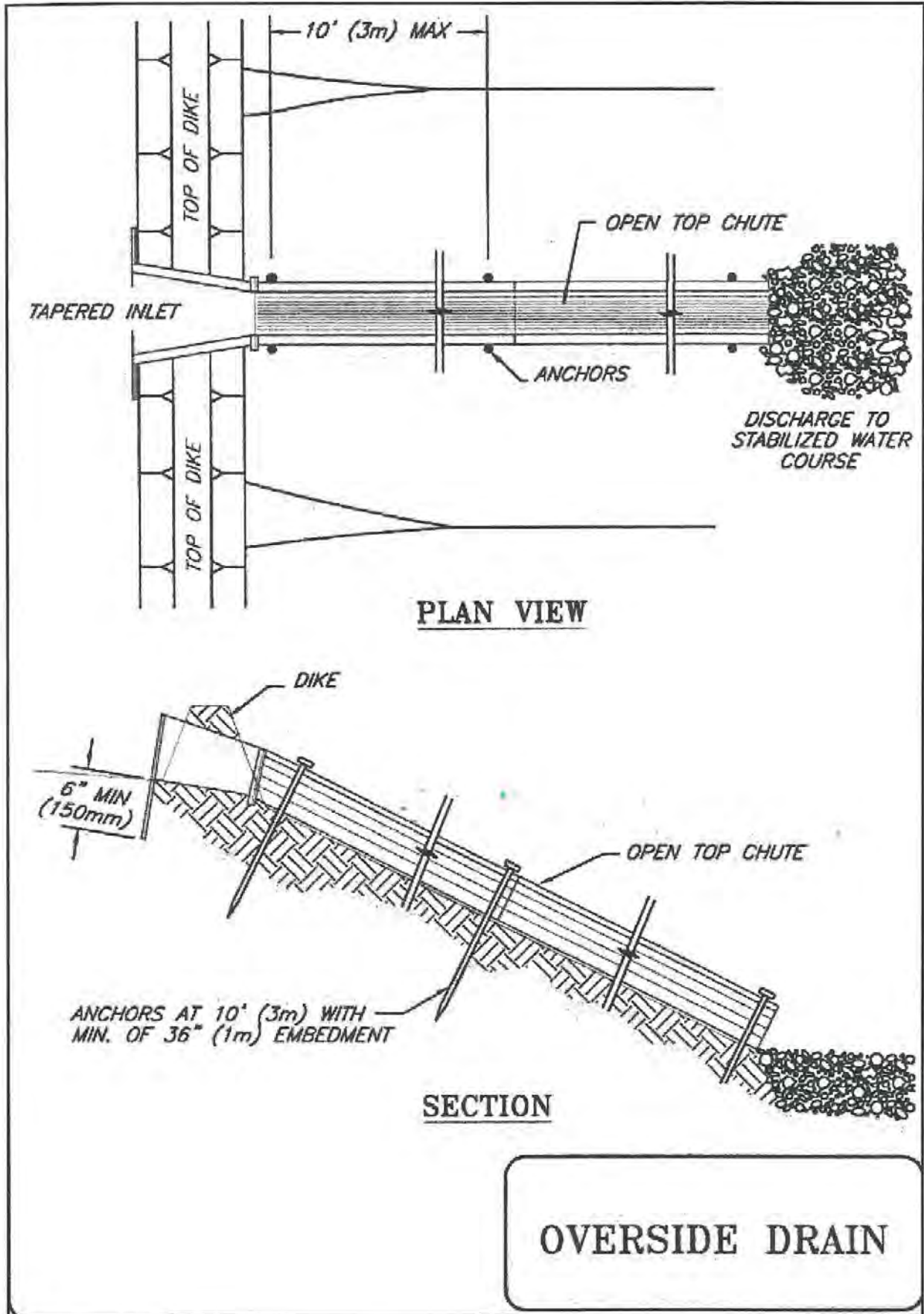

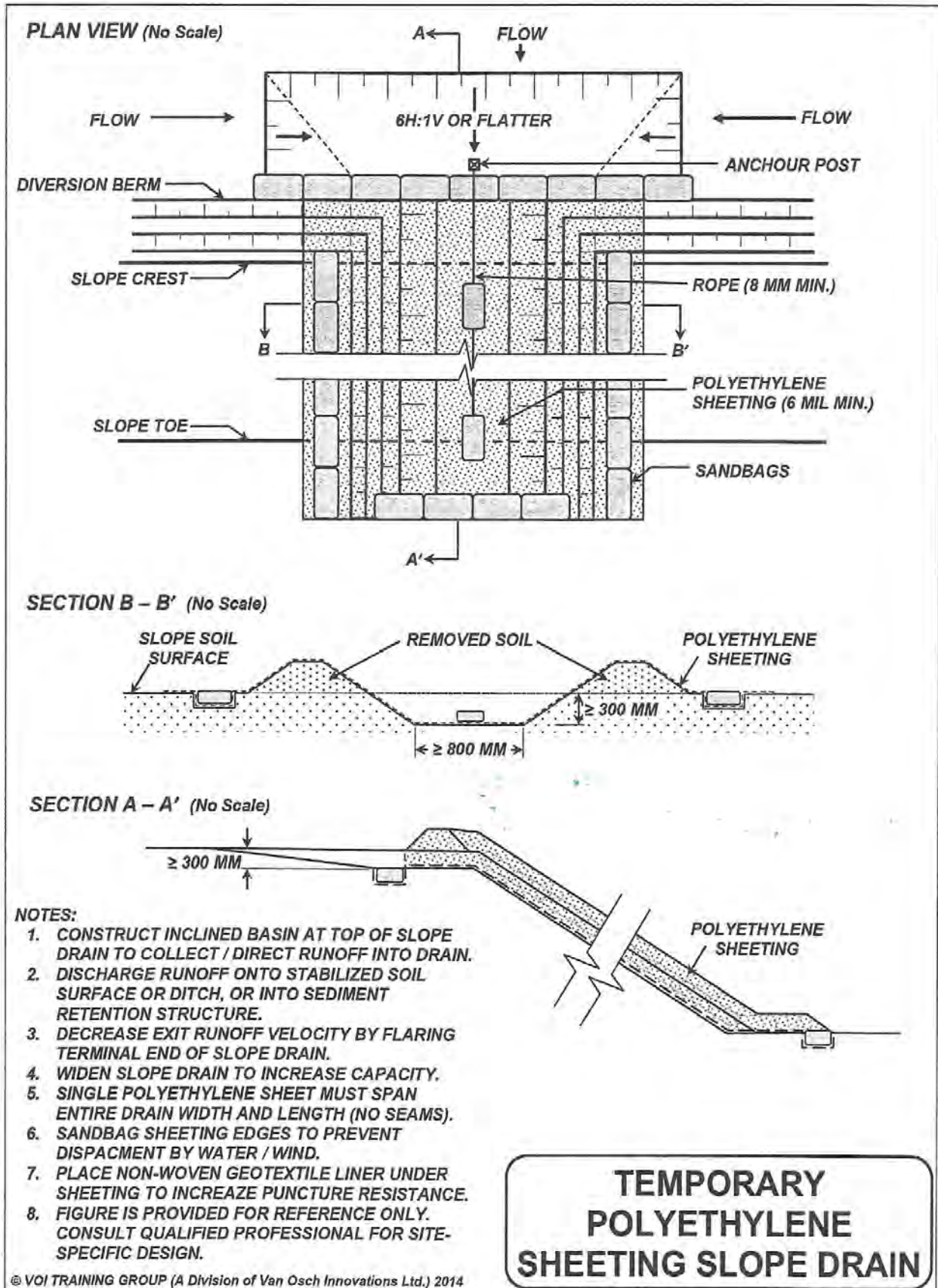



# Sediment Control (ESG-2-Pre)

---

## Application to Ontario Waterways' Projects

Land based construction involving activities such as vegetation removal, topsoil stripping, excavation or soil stockpiling create the potential for soil erosion and sedimentation that can affect surface water quality or deposit fine sediment into adjacent woodlands and wetlands. Protecting exposed soil from erosion and containing run-off to prevent off-site migration and deposition of fine sediment is a critical component of construction and maintenance projects. For this reason, the use of industry accepted standard erosion and sediment control devices are extensively used on both major and small scale land based construction projects on Ontario Waterways.

## Description of Activity

Sediment control involves the installation of barriers on disturbed lands to minimize sediment laden runoff from leaving the work area. This is accomplished by introducing a barrier along a flow path to reduce velocities and dissipate energy together with providing opportunity for sediments to settle. These controls offer the second line of defence after erosion control against the offsite migration of sediment. The use of sediment controls involves properly installing the appropriate device or measure and regularly inspecting and maintaining them.

## Environmental Standards and Guidelines

### Temporary Barriers and Perimeter Controls

Temporary barriers and perimeter controls are used to protect adjacent undisturbed areas and waterbodies down gradient from the work area. They should not be considered as sediment control measure unless it meets the applicable standards and guidelines for installation. They may be used in some circumstances to divert sediment laden or clean water away from unprotected slopes and encroaching onto adjacent sensitive features such as waterbodies, wetlands and forest. In general:

- Uncontrolled sediment entering a waterbody will be considered a spill and must be reported to PCA and the Ontario Ministry of Environment and Climate Change Spills Action Centre (SAC).
- The use of stormwater drain sediment barriers is prohibited.
- The use of straw bale check dams is prohibited. Straw bales are only appropriate for structural support (e.g., sediment pond structural walls) or as straw mulch for erosion control.
- Perimeter earthen berms shall be considered for longer periods of perimeter control consider construction of earthen berms. See Erosion Control ([ESG-1-Pre](#)) for standards and guidelines.

Sediment fences (frequently referred to as silt fences) are temporary sediment barriers consisting of synthetic filter fabric entrenched into the soil with attached wooden or metal posts. A sediment fence does not filter run-off. It is intended create upstream ponding of sediment laden water, allowing the suspended sediment to fall out of suspension. A sediment fence is intended to address moderate sheet flow and is not suitable to treat concentrated flows. Best practices and limitations (VOI, 2005) include:

- The location(s) and type(s) of sediment fence shall be identified in the EMP and accepted by PCA.
- The locations and types of sediment fences shall be determined by a Qualified Professional(s).
- Sediment fences shall not be placed into drainage ditches or into a natural watercourse.
- Sediment fences constructed from woven geotextile fabric are preferred over non-woven fabrics.



- Maximum slope length above a sediment fence should be less than or equal to 30 m.
- Maximum gradient upslope of sediment fence should be less than or equal to 1.5H:1V.
- Maximum length of a single sediment fence from corner to corner should be less than or equal to 40 m.
- Sediment fences shall be installed as per design but generally as illustrated in the Figures below (VOI, 2014).

### Stabilized Site Entrances

Vehicular Tracking Control and Mud Mats are devices placed at construction site access / exit points to stabilize site entrances by removing sediment (mud and debris) from construction vehicles leaving the site and entering adjacent established public roadways. Temporary tracking pads are constructed of clear stone underlain with geotextile material. Mud mats typically consist of high-strength fabric with high tensile reinforcing ribs confined within a sleeve which allows for easy deployment. Mats connect together to form custom sizes. Best practices and limitations (VOI, 2005) include:

- All construction site entrances from public roads shall be stabilized using temporary tracking pads or mud mats. Entrances with steep grades (>8%) shall be avoided.
- The location(s) and type(s) of vehicle tracking controls and mud mats shall be identified in the EMP and accepted by PCA.
- The design of stabilized site entrances, including vehicle tracking controls and mud mats, shall be determined by a Qualified Professional(s).
- Temporary gravel pads shall be constructed from 75 mm or coarser, clean open graded aggregate, with a pad thickness not less than 15 cm placed on non-woven geotextile fabric.
- The pad or mud mats should be designed for the full width of the entrance or a minimum pad/mat width of 3.6 m wide and the minimum pad/mat length of 5 m. Shorter lengths may be required at constrained entrances.
- The stabilized site entrance should be designed in combination with other erosion and sediment control measures and in combination with vehicle wash facilities (as required).

### Sediment Retention Ponds

Sediment retention ponds are constructed depressions that allow runoff to pond and promote settling of sediment. They typically serve as an “end-of-pipe” control, receiving run-off from areas using other primary sediment and erosion control methods. Sediment ponds are generally used to contain runoff or divert flow during heavy precipitation events and improve the detaining of sediment through the active regulation of filling and draining. Passive draining can also be achieved using granular filled perforated risers and pipes. Sediment ponds occupy relatively large areas and are usually only considered on sites with disturbed drainage exceeding 2 ha in size. They are generally effective for 50 to 80% for the design rainfall / runoff event.

Sediment traps are similar to sediment ponds but generally smaller in area. Sediment traps require large surface areas, and as such, are not recommended for drainage areas of more than 2 hectares in size. Used in combination with sediment bags, they are generally placed near areas where sediment laden runoff may enter a waterbody. Traps are generally constructed by excavation within a low area of drainage. Best practices and limitations (VOI, 2005) include:

- The location(s) and sizes of sediment retention ponds and/or traps shall be identified in the EMP and accepted by PCA.
- The location(s) and design of sediment retention ponds and/or traps shall be determined by a Qualified Professional(s).



- Ponds shall be designed to maximize flow path length with a length to width ratio greater than 6:1.
- Embankment materials shall be clean soil placed 2H:1V in lifts not exceeding 140 mm. Soils shall be well compacted. Ponds shall be equipped with a stabilized outlet and an armoured emergency spillway.
- Sediment retention ponds shall be installed as per design but generally as illustrated in the Figures below (VOI, 2014).
- Sediment retention ponds and traps shall be cleaned when approximately 33% of their capacity has been filled with sediment.
- Proactive pumping of sediment retention ponds and traps into filtration bags shall be undertaken to improve the feature's capacity (freeboard). Access to sediment retention ponds shall be maintained in the event that sediment-laden water needs to be removed and filtered.

### Filtration Controls

- Sediment Bags
- Siltsoxx™ and Filter Rings™

Sediment bags are fabricated from non-woven geotextile materials that filter sediment-laden water from dewatering operations. Sediment laden water is pumped into the non-woven geotextile fabric bag that allows filtered water to pass through. Sediment bags are preferred for use on relatively small sites as an effective method of removing sediment rather than larger sediment retention ponds. Sediment bags require frequent routine monitoring to ensure hoses and clamps remain connected and sediment accumulation does not exceed the manufacturer's specifications. Using flocculants will improve flow rates, discharge clarity and percentage of solids retained. Best practices and limitations include:

- The location(s), types and sizes of sediment bags shall be identified in the EMP and accepted by PCA prior to installation.
- The use of flocculants shall be identified in the EMP and accepted by PCA prior to use.
- The location(s), types and sizes of sediment bags shall be determined by a Qualified Professional(s).
- The required size structural integrity and flow rate of the sediment bag is dependent upon soil type in the dewatering area, pumping rates.
  - Sediment bags should be sized to accommodate a minimum of two times the peak flow rate generated from the dewatering pump to account for a 50% clogging factor.
  - Maximum pumping rate is typically 18,170 liters / hour.
- Sediment bag locations shall be relatively flat. Sediment bags can be placed directly on the ground surface, but can also be placed on a thin gravel pad, jute or straw mats. Sediment bags can be co-located with sediment retention ponds in the event that sediment laden water needs to be removed and filtered in the bag.
- Remove and replace sediment bags when half full of sediment or when discharge rate is not being achieved.

Siltsoxx™ and Filter Rings™ are temporary filtration devices that incorporate filter media inside a prefabricated semipermeable material to filter water passing through the device. Siltsoxx also promote ponding to create settling of fine sediment behind the device and can therefore also be used as a settling control. Siltsoxx™ is typically used to prevent or reduce sheet flow on areas up to and exceeding a 2:1 slope. Both Siltsoxx™ and Filter Rings™ also have the ability to bind various contaminants contained in run-off. Siltsoxx and similar devices can be provided in biodegradable forms, allowing the addition of



seeds to promote the establishment of vegetation directly in the Soxx, thus avoiding the need to remove the device and disturb the soil.

### Turbidity Curtains

Turbidity curtains consist of geotextile material vertically suspended in water to enclose an in-water work area and contain sediment transport to a limited area within the disturbed water body. They are used around construction activities undertaken in-water. The turbidity curtains act as a filter baffle and isolate/protect an important or sensitive in-water feature. Turbidity curtains should not be used as a primary or secondary settling area for dewatering activities. Best practices and limitations include:

- The location(s), types and sizes of turbidity curtains shall be identified in the EMP and accepted by PCA prior to installation.
- The location(s) and type of turbidity curtains shall be determined by a Qualified Professional(s).
- Turbidity curtains must be used when constructing or removing coffer dams. They should be placed according to OPSD 219.260 and 219.261 for the Turbidity Curtain specifications and as close to the coffer dam as possible to minimize area of potential impact of sedimentation.
- Curtain should be positioned at least five (5) metres outside of the perimeter of the area of disturbance.
- Floatation devices should provide greater than 50 mm of freeboard.
- Curtains should be overlapped by at least 75 mm at the ends and should be sewn or threaded to form a continuous barrier.

### Inspection and Maintenance of Sediment Controls

- An inspection program (e.g., performance monitoring) that evaluates the integrity, functionality and effectiveness of sediment control methods shall be described in the EMP and accepted by PCA.
- Inspection of sediment controls within the construction area shall be undertaken a twice weekly, in advance of and following each rainfall or snowmelt event, and repaired as required. The inspections are intended to:
  - confirm sediment control methods and devices have been installed according to the contract plans and correctly according to installation standards;
  - confirm sediment control methods and devices are maintained and functioning as intended; and,
  - identify deficiencies of selected measures based on observations of terrain, soils, or construction progress.

### Related Environmental Standards and Guidelines

- General Environmental Protection Procedures
- Erosion Control (ESG-1-Pre)
- Soil Stripping, Grubbing and Stockpiling (ESG-3-Pre)
- Vegetation Clearing and Protection (ESG-5-Pre)
- Treatment of Discharge Waters (ESG-14-C)

### Related EMP Component Plans

- Dust and Air Quality Management
- Blasting



- Demolition
- Site Dewatering and Wastewater Management
- Surface Water Management, Erosion and Sediment Control
- Dredging and Sediment Removal
- Vegetation Protection
- Wildlife Protection and Management
- Aquatic Resources Management
- Spills Prevention and Emergency Response
- Dam and/or Bypass Channel Commissioning
- Site Restoration

### *Other Design and Environmental Considerations*

All sediment controls shall be designed to control a specified area, slope and sediment type.

- All sediment controls shall be designed to control a specified area, slope and sediment type.
- Timing of works should avoid seasonally high rainfall and snowmelt periods.
- Timing windows for in-water works shall be respected.

### *Further Guidance*

OPSD 219.260 for Turbidity Curtains, November 2015. Available at:  
[http://www.ragsb.mto.gov.on.ca/techpubs/ops.nsf/0/86fe295ab74b61158525808200628e17/\\$FILE/OPSD%20219.260%20Rev%232%20Nov2015.pdf](http://www.ragsb.mto.gov.on.ca/techpubs/ops.nsf/0/86fe295ab74b61158525808200628e17/$FILE/OPSD%20219.260%20Rev%232%20Nov2015.pdf)

OPSD 219.261 for the Turbidity Curtains Seam Details, November 2016. Available at:  
[http://www.ragsb.mto.gov.on.ca/techpubs/opsa.nsf/0/2ea4866bb726ba7e85257fae006851ee/\\$FILE/OPSD219.261%20Rev%231%20Nov2006.pdf](http://www.ragsb.mto.gov.on.ca/techpubs/opsa.nsf/0/2ea4866bb726ba7e85257fae006851ee/$FILE/OPSD219.261%20Rev%231%20Nov2006.pdf)

### *References*

CISEC, 2014. Certified Inspector and Sediment and Erosion Control Training Manual. Revised Edition V6. 9520 Pine valley Drive, Woodbridge Ontario, Canada.

Erosion and Sediment Control Guidelines for Urban Construction, 2006. Greater Golden Horseshoe Area Conservation Authorities.

VOI Training Group, 2005. Erosion and Sediment Control – Participant’s Manual. Developed by Van Osch Innovations Ltd., 130 Columbia Street, Nanaimo, British Columbia, Canada.

VOI Training Group, 2014. Environmental Field Procedures for Works in and About Water. Developed by Van Osch Innovations Ltd., 130 Columbia Street, Nanaimo, British Columbia, Canada.

ASSUMING A SEDIMENT FENCE SLOPE OFFSET ON FLAT GROUND OF  $\geq 2000$  MM AND AN INSTALLED HEIGHT OF 610 MM:

1. SLOPE LENGTH ABOVE SEDIMENT FENCE  $\leq 30$  M
2. SLOPE GRADIENT ABOVE FENCE  $\leq 1.5H:1V$
3. DRAINAGE AREA  $\leq 33$  M<sup>2</sup> / M OF FENCE (CORNER-TO-CORNER LENGTH)

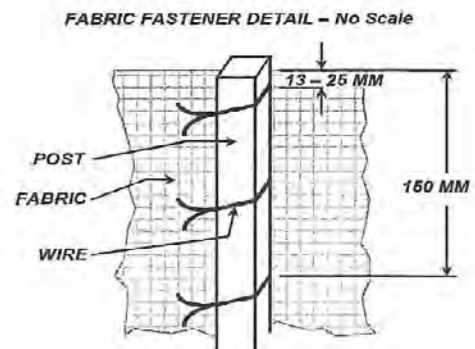
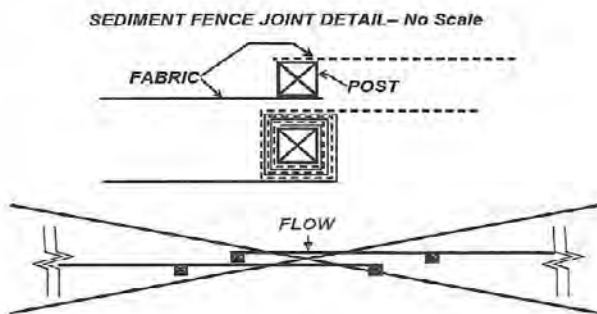
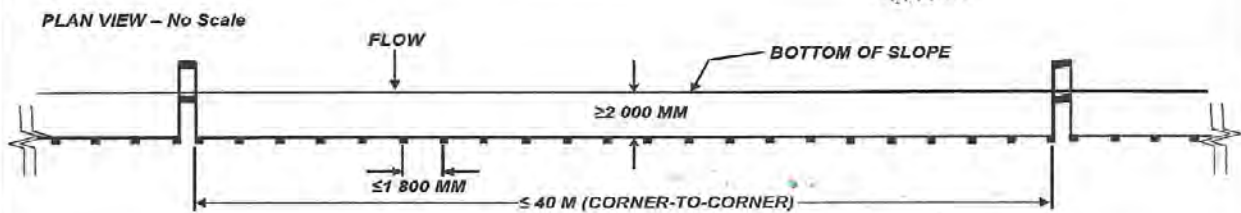
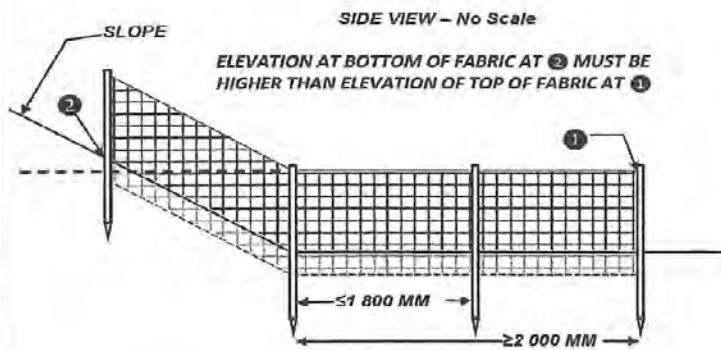
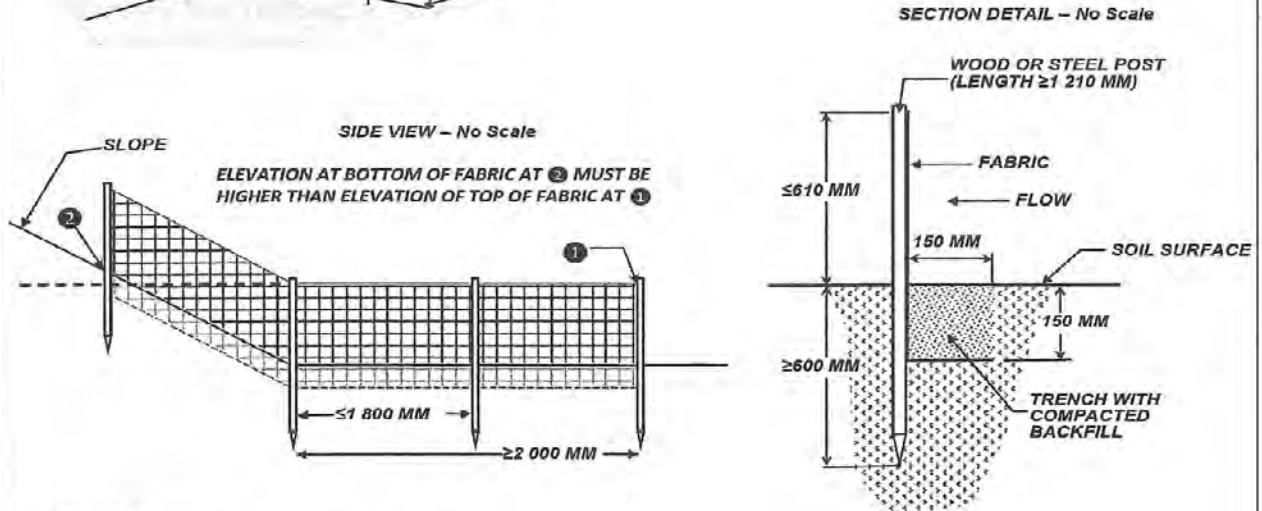
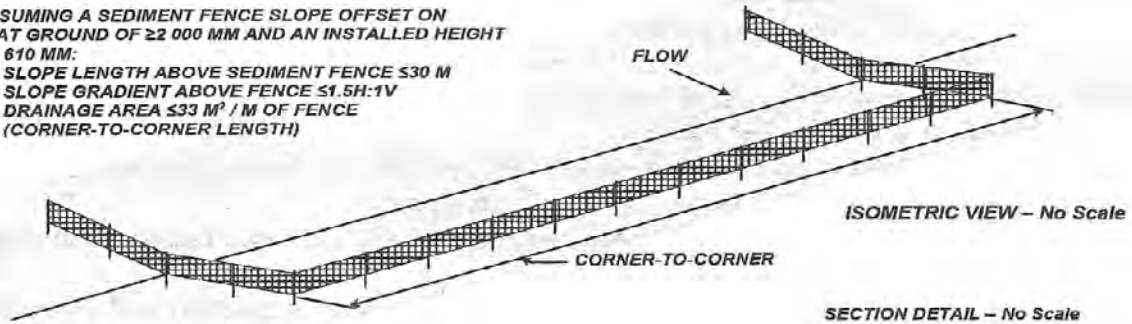

NOTES:

1. SEDIMENT FENCE MUST BE CORRECTLY CONFIGURED, INSTALLED AND MAINTAINED FOR EFFECTIVE SEDIMENT CONTROL FUNCTION.
2. SEDIMENT FENCE FUNCTIONS BY POOLING RUNOFF TO PROMOTE SEDIMENTATION.
3. RUNOFF THROUGH, UNDER OR AROUND FENCE IS NOT DESIREABLE.
4. DO NOT INSTALL ACROSS WATERCOURSES OR DRAINAGEWAYS.
5. ENHANCE INTEGRITY OF SEDIMENT FENCE BY INSTALLING ADDITIONAL POSTS.
6. SEDIMENT FENCING, IF INSTALLED CORRECTLY, DOES NOT REQUIRE WIRE BACKING.
7. FUNCTIONAL LIFE OF SEDIMENT FENCE IS 1 YEAR.
8. FIGURE IS PROVIDED FOR REFERENCE ONLY. CONSULT QUALIFIED PROFESSIONAL FOR SITE-SPECIFIC DESIGN.

SEDIMENT FENCE



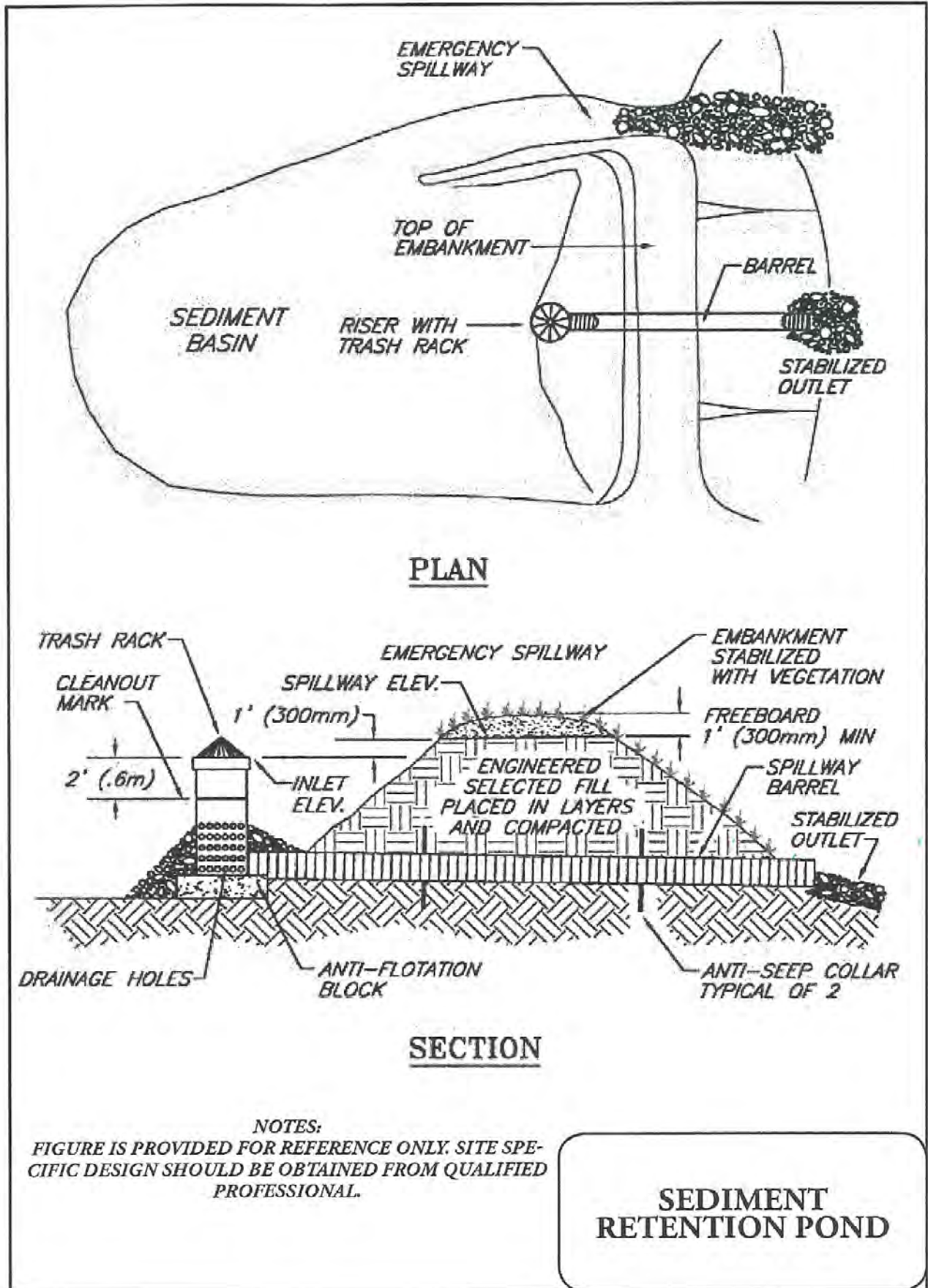



# Soil Stripping, Grubbing & Stockpiling (ESG-3-Pre)

---

## Application to Ontario Waterways' Projects

Land based construction typically involves the disturbance and removal (stripping) of topsoil prior to excavation or contouring earthworks. The storage of stripped topsoil or other excavated surficial material creates stockpiles of erodible material that require management due to the potential for soil erosion and sediment transport into adjacent waterbodies, wetlands or forests. Proper removal and separation of topsoil from underlying soil layers preserves naturally occurring seed banks and provides a growing media that can be used during the site restoration phase. During construction and maintenance projects it is also important to protect exposed soil from erosion and to contain run-off to prevent off-site migration and deposition of fine sediment. For these reasons, the use of industry accepted standards for Soil stripping and stockpiling are used on all land based construction projects on Ontario Waterways. Soil stripping, grubbing and stockpiling activities also have invasive species management requirements.

## Description of Activity

Soil stripping involves the intentional removal of the active soil layer in which rainwater, small animals and micro-organisms interact with soil particles to create conditions suitable for the growth and maintenance of vegetation. The term 'topsoil' generally refers to the A soil horizon which is usually darker than the underlying soil because of the accumulation of organic matter. Stripping is typically performed using graders or earth scrapers to remove the active growing soil layer. Storage of removed material is often accomplished by creating storage piles (stockpiles) in designated areas for later retrieval of the material.

## Environmental Standards and Guidelines

General guidelines for soil management have the following objectives:

- Do not admix (i.e., mixing topsoil with other material). This helps to preserve topsoil value.
- If subsoil becomes compacted soil de-compaction measures shall be implemented (See Revegetation (ESG-1-Post)).
- All topsoil must be retained for re-use during the post-construction period.
- No vegetation shall be removed or soil shall be disturbed in riparian areas (i.e., next to wetlands and watercourses), unless identified in the site-specific EMP and accepted by PCA.

## Soil Stripping

- All soil stripping locations and volumes must be identified in the site-specific EMP and accepted by PCA.
- Restrict topsoil stripping to areas that will be disturbed by the construction activities. Project staging must be described in the Construction Plan of the site-specific EMP.
- Sediment control measures must be in place prior to commencement of soil stripping activities. Erosion control measures shall be implemented for all areas following stripping;
- Vegetated buffer strips;
- Ensure full salvage of topsoil and upper root zone while avoiding admixing soil layers;



- During frozen soil conditions, topsoil/root zone salvage work is to be conducted using specialized equipment (e.g., frozen topsoil cutter) with fine excavation depth control to remove soil horizon of variable depths.

### Grubbing

- All areas to be grubbed and their timing must be identified in the site-specific EMP and accepted by PCA.
- Grubbing should not be conducted unless a Site Restoration plan as part of the site-specific EMP has been accepted by PCA.
- The National Master Specification (NMS) Section 31 11 00 – Clearing and Grubbing, and OPSS 201 Guideline for “Clearing, Close Cut Clearing, Grubbing, Removal of Boulders and Mechanical Stump Cutting”, shall be adhered to during clearing and grubbing operations unless specified otherwise in the Historic Canals Regulations permit.
- Grubbing should not proceed too far ahead of construction. This will limit the time that the mineral soil is exposed to erosion.
- All stumps and visible surface roots shall be removed except where removal might endanger the health or stability of a nearby tree or other preserved element that has been identified for retention.
- Cleared and grubbed material shall be stockpiled in separate locations from growing medium stockpiles. Where noxious or undesirable weeds are found on site, grubbed materials shall not be used as a constituent of, or as a growing medium.
- Grubbing material should not be piled where it will block drainage courses.
  - If windrows are used, they should be kept behind roadside ditches and breaks should be provided so animals can move across the right-of-way (approximately 5 metres every 65 metres).
  - If push-outs are used, they should be pre-cut to a large enough size to avoid knockdown of standing trees.
- Remove material and debris, and dispose of at an authorized disposal site.
- Trees and shrubs removed from work areas during vegetation clearing activities shall be shredded and used as mulch on newly exposed surfaces. Mulch will be weed-free to prevent the introduction of invasive species.

### Stockpile Management

- All stockpile locations, areas, heights and storage volumes must be identified in the site-specific EMP and accepted by PCA.
- Special attention shall be given to the placement and management of the salvaged topsoil and soils from other horizons.
  - Avoid stockpiling in low-lying wet areas that will result in saturated soils or in areas receiving site drainage flow.
  - Do not place geotextile material under topsoil stockpiles as such materials are subject to tearing mixing upon removal.



- When stockpiling topsoil, mound soil no higher than 1.3 m high for less than 1 year and preferably less than 6 months. Where space limitations necessitate higher mounds, topsoil stockpiles should not exceed 3 m.
  - Short-term stockpiles (< 6 months) should be covered with tarps or woven geotextile materials to prevent erosion and contamination by weeds during storage.
  - Longer term stockpiles (>6 months) should be stabilized by temporarily establishing ground cover vegetation using native Ontario species, either by application of seeded compost or seeded biodegradable mats.
- Ensure all stockpiles are protected with perimeter sediment controls (see Sediment Control (ESG-2-Pre)) and apply appropriate erosion control methods (see Erosion Control (ESG-1-Pre)).
- Clearly separate windrows/stockpiles of soils from different horizons, ensuring to stockpile topsoil/root zone and underlying mineral material separately and excavate in depth sequence.
- Where topsoil is stockpiled greater than 1.3 m or longer than 6 months, the soil shall be amended with compost to re-establish health soil structure and restore soil organism populations.
- Soil stockpiles shall be inspected monthly and every 6 months during construction for growth of noxious or invasive species.

#### *Related Environmental Standards and Guidelines*

- General Environmental Protection Procedures
- Erosion Control (ESG-1-Pre)
- Sediment Control (ESG-2-Pre)
- Soil Stripping, Grubbing and Stockpiling (ESG-3-Pre)
- Vegetation Clearing and Protection (ESG-5-Pre)
- Revegetation (ESG-1-Post)

#### *Related EMP Component Plans*

- Dust and Air Quality Management
- Transportation Management
- Surface Water Management, Erosion and Sediment Control
- Vegetation Protection
- Species at Risk Protection
- Invasive Species Management
- Waste Management
- Site Restoration

#### *Other Design and Environmental Considerations*

- Timing of works should avoid seasonally high rainfall and snowmelt periods.
- Timing windows for in-water works shall be respected.



### *Further Guidance*

National Research Council of Canada, 2015. National Master Specification (NMS) Section 31 11 00 – Clearing and Grubbing. Revised August, 2015.

Government of Ontario, 2011. Ontario Provincial Standard Specification OPSS 201. Construction Specification for Clearing, Close Cut Clearing and Removal of Surface and Piled Boulders, Grubbing. November 2011.

### *References*

CISEC, 2014. Certified Inspector and Sediment and Erosion Control Training Manual. Revised Edition V6. 9520 Pine valley Drive, Woodbridge Ontario, Canada.

Greater Golden Horseshoe Area Conservation Authorities, 2006. Erosion and Sediment Control Guidelines for Urban Construction.

Toronto and Region Conservation Authority, 2012. Preserving and Restoring Healthy Soil: Best Practices for Urban Construction. Version 1.0., June, 2012.

VOI Training Group, 2014. Environmental Field Procedures for Works in and About Water. Developed by Van Osch Innovations Ltd., 130 Columbia Street, Nanaimo, British Columbia, Canada.



# Tree Protection and Hording (ESG-4-Pre)

---

## Application to Ontario Waterways' Projects

Construction projects on Ontario Waterways are undertaken on lands that are often well vegetated with natural vegetation or grounds that have been landscaped. Individual or specimen trees may occur throughout a site and may require isolation and protection prior to site preparation works and activities (e.g., clearing, grubbing, installation of erosion and sediment controls) to prepare laydown areas, storage areas, camps, access roads/trails etc. In some cases the relocation or transplanting of trees may be warranted.

## Description of Activity

Tree protection and hording involves the identification and delineation of areas and individual specimen trees to be avoided and protected from potentially damaging works and activities.

## *Environmental Standards and Guidelines*

### Trees to be Protected

All individual or specimen trees to be retained and requiring protection must be identified in the site-specific EMP and accepted by PCA. To the extent possible, retain trees >10 cm DBH intact and instead, remove lower limbs (<2.5 m high).

- All individual or specimen trees to be retained and requiring protection must be identified in the site-specific EMP and accepted by PCA. To the extent possible, retain trees >10 cm DBH intact and instead, remove lower limbs (<2.5 m high).
- Relocation or transplanting of any trees is prohibited unless accepted by PCA in the site-specific EMP. All relocations or transplanting of trees shall be planned and supervised by a Certified Arborist.
- All project personnel are to be informed of the exact location of individual or specimen trees to be retained and their protection requirements. Any special treatments or protection requirements shall be established identified in the site-specific EMP and accepted by PCA.
- Damaged trees designated for protection require assessment by a Certified Arborist.
- Delineate individual or specimen trees to be protected with flagging tape, temporary protective fence, hording or other suitable protection measures.
- The area to be protected for any individual or specimen tree shall be at a minimum radius, the area within the tree's "drip-line" plus a 1.5 m distance. This is applicable to both deciduous trees and conifers.
- The following activities are not permitted within the protected area:
  - Changes, alteration, or disturbance to grade by filling, excavating, or scraping, except as indicated in the contract documents.
  - Storage of construction materials and equipment.
  - Stockpiling of construction materials and excavated materials.
  - Disposal of liquids, including concrete slurry, gas, oil, and paint.
  - Vehicular traffic, equipment, or pedestrian traffic.
  - Attachment of wires, ropes, lights, or other such attachments other than those of a protective nature to trees to be preserved.
  - Cleaning of equipment or material under canopy of tree or group of trees to be preserved.



### Protective Fencing

Individual or specimen trees to be protected shall be fenced off by either:

- Individual or specimen trees to be protected shall be fenced off by either:
  - Chain link fence of at least 1.2 m height mounted on steel or sturdy wooden posts. Fence posts should be placed no farther than 2.4 m apart.
  - Solid plywood hoarding mounted securely on durable wooden posts. Fence posts should be placed no farther than 2.4 m apart.
  - Board fencing (i.e., hording) consisting of 100 mm square posts set securely in the ground and extending at least 1 m above the ground shall be placed as in Table 3-1, with a minimum of two horizontal boards fastened securely between posts. Fence posts should be placed no farther than 2.4 m apart.
  - Plastic fencing, “international orange” plastic (polyethylene) web fencing securely mounted on a sturdy wooden framework that includes top and bottom rail. Fence posts should be placed no farther than 2.4 m apart, or
  - Plastic fencing, “international orange” plastic (polyethylene) web fencing secured to conventional metal “T” or “U” posts driven to a minimum depth of 450 mm on 2 m minimum centers shall be installed at the limits of clearing. Plastic snow fencing should not be tied to metal stakes or rebar.

### Root Protection Measures

- In the event that the installation of protective fencing for an individual or specimen tree is not possible and/or ideal, alternative measures (e.g., blasting mats, mud mats) must be implemented with prior acceptance by PCA. Such measures must provide a sufficient amount of soil compaction prevention with regards to the highest level of activity to occur within the immediate area of protection.
  - For areas of light-to-medium levels of traffic activity, a geotextile cloth shall be placed over the area of protection and covered with a 20 cm (at minimum) thick layer of mulch material. Pins or staples must be used to anchor the geotextile material to the ground.
  - For areas of medium-to-high levels of traffic activity, a geotextile cloth shall be placed over the area of protection and covered with a 20 cm (at minimum) thick layer of mulch material. The mulch material shall then be covered with 2 cm (3/4 inch) sheets of laminated plywood. Large sheets are preferred.
- Mulch material should not be permitted to pile against the trunk(s) or root flare(s) of the tree(s), as this may lead to unwanted bark rot and oxygen deprivation, subsequently leading to the death of the tree(s).

### Inspections and Maintenance

- Fencing and root protection measures shall be inspected monthly.
- Plywood sheets and mulch must be replaced and replenished as necessary to maintain the 20 cm root protection layers thickness at all times.
- Any damaged fencing, hording or other approved protection measures shall be replaced immediately.
- Fencing and armoring devices shall only be removed after the completion of the project, following the final cleanup.



### *Related Environmental Standards and Guidelines*

- General Environmental Protection Procedures
- Erosion Control (ESG-1-Pre)
- Sediment Control (ESG-2-Pre)
- Soil Stripping, Grubbing and Stockpiling (ESG-3-Pre)
- Vegetation Clearing and Protection (ESG-5-Pre)
- Invasive Species Management (ESG-11-C)
- Revegetation (ESG-1-Post)

### *Related EMP Component Plans*

- Vegetation Protection
- Species at Risk Protection

### *Other Design and Environmental Considerations*

- Timing windows for migratory birds and in-water works shall be respected.

### *References*

Government of Ontario, 2011. Ontario Provincial Standard Specification OPSS 201. Construction Specification for Clearing, Close Cut Clearing and Removal of Surface and Piled Boulders, Grubbing. November 2011.

Landscape Ontario Horticultural Trades Association, 2004. Landscape Guidelines. Available at: [http://landscapeontario.com/attach/1246977850.Landscape\\_Guidelines.pdf](http://landscapeontario.com/attach/1246977850.Landscape_Guidelines.pdf).

Ontario Ministry of Natural Resources, 2009. Environmental Guidelines For Access Roads and Water Crossings.





# Vegetation Clearing and Protection (ESG-5-Pre)

---

## Application to Ontario Waterways' Projects

Site preparation for a construction project on PCA property may require the removal of natural vegetation to prepare for construction. Areas of a construction site that typically require large areas to be cleared are laydown areas, storage areas, locations of camps, new access roads or trails etc. Practically all projects completed by Parks Canada on Ontario Waterways occur in close proximity to fish bearing waterbodies. The protection of fish habitat and water quality during near water and in water construction projects is of critical importance to Park Canada. Protecting existing vegetation, especially in close proximity to waterbodies, reduces the potential for soil erosion and sedimentation (off-site migration and deposition of fine sediment) at construction sites. For these reasons, the protection of riparian vegetation is applicable to most major and small scale construction projects on Ontario Waterways. This ESG applies to the removal and protection of common, natural (non-SAR) vegetation.

## Description of Activity

The primary objective of vegetation protection is to identify and retain as much vegetated areas as possible. On land this is accomplished by delineating protection or “no go” zones. Near water this is accomplished maintaining or creating a buffer strip along the riparian zone to maintain of a healthy aquatic environment. Overall, protection is accomplished by limiting the removal of vegetation, avoiding unnecessary intrusion, and delaying removals until just before the area is about to be worked. Vegetative buffers protect adjacent waterbodies or wetlands from the effects of sedimentation and stabilize the shoreline against erosion and bank failure. Nevertheless, some vegetation clearing will likely be necessary for most projects. Vegetation clearing involves felling, trimming, and cutting of trees and shrubs, the removal (e.g., downed timber, snags, brush,), and grass cutting occurring within areas to be cleared in preparation for construction (i.e., not a maintenance activity).

## Environmental Standards and Guidelines

- All vegetation clearing activities are subject to compliance with the *Migratory Birds Convention Act*. Vegetation clearing work shall not be undertaken during the active bird breeding season (April 1st to August 31st),
- All vegetated areas to be cleared must be identified in the site-specific EMP and accepted by PCA. An inventory of species to be removed shall be undertaken.
- All vegetated areas to be protected must be identified in the site-specific EMP and accepted by PCA. No vegetation shall be removed until all protection or “no go” zones are established and accepted by PCA.

## Vegetated Areas to be Protected

- Clearing of vegetation, including the clearing of vegetation in riparian areas, shall be minimized.
- All vegetated areas (e.g., forested areas, riparian areas, other vegetated buffers) to be retained and requiring protection must be identified in the site-specific EMP and accepted by PCA.
- All project personnel are to be informed of the exact location of the areas to be retained and their protection requirements. Any special treatments or protection requirements shall be established identified in the site-specific EMP and accepted by PCA.



- Vegetated areas to be protected shall be delineated with flagging tape, temporary protective fence, hording or other suitable protection measures.
- The forested area to be protected shall be a minimum distance from the largest “drip-line” plus a 1.5 m distance. This is applicable to both deciduous trees and conifers within a forested area.
- The following activities are not permitted within the protected area:
  - Changes, alteration, or disturbance to grade by filling, excavating, or scraping, except as indicated in the contract documents.
  - Storage of construction materials and equipment.
  - Stockpiling of construction materials and excavated materials.
  - Disposal of liquids, including concrete slush, gas, oil, and paint.
  - Vehicular traffic, equipment, or pedestrian traffic.
  - Attachment of wires, ropes, lights, or other such attachments other than those of a protective nature to trees to be preserved.
  - Cleaning of equipment or material under canopy of tree or group of trees to be preserved.

#### Protective Fencing

- Vegetated areas, including riparian area buffers, to be protected shall be fenced off by either:
  - Chain link fence of at least 1.2 m height mounted on steel or sturdy wooden posts. Fence posts should be placed no farther than 2.4 m apart.
  - Solid plywood hoarding mounted securely on durable wooden posts. Fence posts should be placed no farther than 2.4 m apart.
  - Board fencing (i.e., hording) consisting of 100 mm square posts set securely in the ground and extending at least 1 m above the ground shall be placed as in Table 3-1, with a minimum of two horizontal boards fastened securely between posts. Fence posts should be placed no farther than 2.4 m apart.
  - Plastic fencing, “international orange” plastic (polyethylene) web fencing securely mounted on a sturdy wooden framework that includes top and bottom rail. Fence posts should be placed no farther than 2.4 m apart, or
  - Plastic fencing, “international orange” plastic (polyethylene) web fencing secured to conventional metal “T” or “U” posts driven to a minimum depth of 450 mm on 2 m minimum centers shall be installed at the limits of clearing. Plastic snow fencing should not be tied to metal stakes or rebar.

#### Clearing and Debris Handling Methods

- Vegetation clearing shall be undertaken in accordance with National Master Specification (NMS) Section 31 11 00 – Clearing and Grubbing (2015).
- Staging and sequencing of vegetation clearing shall be planned to coincide with construction activities and the installation of erosion and sediment controls.
  - Where advanced vegetation clearing is necessary, leave the vegetative ground mat and root structure intact to the extent practicable.
  - If riparian vegetation is to be removed, erosion and sediment control measures shall be in place prior to the commencement of clearing activities.
- Trees shall only be cut using tools designed for tree cutting activities (e.g., chainsaws, brush saws). Tree removal or pruning shall be a clean cut. Work on mature trees near power lines, overhead facilities or adjacent to public roads should be undertaken under the supervision of a Certified Arborist. The *Ontario Occupational Health and Safety Act* requires that people and equipment keep a minimum distance of 3 m from high voltage power lines (750 volts and above).



- Trees shall only be cut using tools designed for tree cutting activities (e.g., chainsaws, brush saws). Tree removal or pruning shall be a clean cut. Work on mature trees near power lines, overhead facilities or adjacent to public roads should be undertaken under the supervision of a Certified Arborist. The *Ontario Occupational Health and Safety Act* requires that people and equipment keep a minimum distance of 3 metres from high voltage power lines (750 volts and above).
- Vegetation clearing from unstable or erodible banks or riparian areas shall be minimized or undertaken by hand. Use of heavy machinery will not be acceptable.
- Use equipment with wide track or “high float” rubber tired vehicles and having a greater reach to reduce the overall area of disturbed vegetation and soil compaction.
- Woody material less than 10 cm DBH of non-invasive species will be chipped or mulched. The material will be stored on-site to supplement erosion and sediment controls when required. Surplus material should either be stored or disposed off-site.
- Logs of 10 cm DBH or greater may be left on-site with approval of PCA.
- Burning of vegetation or other debris is prohibited.

#### *Related Environmental Standards and Guidelines*

- General Environmental Protection Procedures
- Erosion Control (ESG-1-Pre)
- Sediment Control (ESG-2-Pre)
- Soil Stripping, Grubbing and Stockpiling (ESG-3-Pre)
- Tree Protection and Hording (ESG-4-Pre)
- Vegetation Clearing and Protection (ESG-5-Pre)
- Invasive Species Management (ESG-11-C)
- Use and Maintenance of Heavy Equipment (ESG-15-C)
- Wildlife and Species at Risk Protection During Construction (ESG-17-C)
- Revegetation (ESG-1-Post)

#### *Related EMP Component Plans*

- Dust and Air Quality Management
- Transportation Management
- Surface Water Management, Erosion and Sediment Control
- Vegetation Protection
- Species at Risk Protection
- Invasive Species Management
- Waste Management
- Site Restoration

#### *Other Design and Environmental Considerations*

- Timing of works should avoid seasonally high rainfall and snowmelt periods.
- Timing windows for in-water works shall be respected.



### *Further Guidance*

Government of Ontario, 2011. Ontario Provincial Standard Specification OPSS 201. Construction Specification for Clearing, Close Cut Clearing and Removal of Surface and Piled Boulders, Grubbing. November 2011.

National Research Council of Canada, 2015. National Master Specification (NMS) Section 31 11 00 – Clearing and Grubbing. Revised August, 2015.

### *References*

Coker, G.A., Ming, D.L., and Mandrak, N.E. 2010. Mitigation Guide For The Protection Of Fishes and Fish Habitat To Accompany The Species at Risk Recovery Potential Assessments Conducted by Fisheries and Oceans Canada (DFO) in Central and Arctic Region. Version 1.0. Can. Manusc. Rep. Fish. Aquat. Sci. 2904: vi + 40 p.

Environment Yukon, 2011. Best Management Practices for Works Affecting Water in Yukon. Water Resources Branch, Government of Yukon.

Erosion and Sediment Control Guidelines for Urban Construction, 2006. Greater Golden Horseshoe Area Conservation Authorities.

Landscape Ontario Horticultural Trades Association, 2004. Landscape Guidelines. Available at: [http://landscapeontario.com/attach/1246977850.Landscape\\_Guidelines.pdf](http://landscapeontario.com/attach/1246977850.Landscape_Guidelines.pdf).

Ontario Ministry of Natural Resources, 2009. Environmental Guidelines For Access Roads and Water Crossings.

VOI Training Group, 2014. Environmental Field Procedures for Works in and About Water. Developed by Van Osch Innovations Ltd., 130 Columbia Street, Nanaimo, British Columbia, Canada.



# Abrasive Blasting (ESG-1-C)

---

## Application to Ontario Waterways' Projects

Repairs and upgrades to locks, walls, dams and bridges may require abrasive blasting to remove rust, scale, paint, etc., from surfaces in preparation for finishing.

## Description of Activity

The process of abrasive blasting uses compressed air to propel the abrasive material at high speeds to remove the old surface finish. Significant amounts of dust are generated during the process. A variety of abrasive materials can be used and include: silica sand, glass beads, metal slag (e.g., Kleen Blast), steel grit, metal shot, and aluminum oxide. In the case of wet blasting, water is used as the abrasive media along with compressed air to achieve the desired surface finish. Wet abrasive blast cleaning is also known as wet blasting or vapor abrasive blast cleaning. Abrasive blasting will result in the generation of solid and/or liquid wastes. The primary types of solid wastes are spent abrasives and removed coating materials, rust and scale. Other solid wastes may include off-specification coatings, contaminated soils, protective clothing and materials damaged during blasting operations. Liquid wastes are typically waters contaminated by coatings, rust and scale.

## Environmental Standards and Guidelines

- The proposed use of abrasive blasting and the types of wastes that may be produced must be identified in the site-specific EMP and accepted by PCA.
- All abrasive blasting must be carried out in an approved abrasive blasting enclosure. Options include:
  - *Partial or Full Enclosure:* A partial or full enclosure is to be used when the abrasive blasting procedure is carried out in proximity to any residential area or watercourse. The abrasive blasting area is partially enclosed with a tarp on the floor to collect spent debris and partial side enclosures to prevent particles from being blown around. The sides of the enclosure shall be as high as the area which is being worked on. A full enclosure involves an abrasive blasting area that is enclosed on all sides including the top of the area.
  - *Full enclosure with negative pressure:* A full enclosure with negative pressure is to be used when escape of all or any materials or debris from the operations must be prevented. The abrasive blasting area is an area which is sealed tight on all joints and entryways to prevent any leakage of dust. It utilizes negative pressure from forced airflow along with dust collectors.
- The spent abrasive material must be cleaned out of the working area at least once a day. If heavy abrasive blasting with high accumulations of dust occurs, the area may need to be cleaned on a more regular basis (e.g., at end of shift or when sectional tasks are completed).
- Where wet abrasive blasting is carried out, care must be taken due to the accumulation of water on the floor area. Waters used in wet abrasive blasting must be separated and isolated in the work areas. If wet abrasive blasting is carried out, only a partial enclosure is required.



### Spent Abrasives and Wastewater Management

- Spent abrasives along with waste generated, must be contained in covered containers with appropriate visible labels until tested.
- Spent abrasives, wastewater and other wastes generated during abrasive blasting operations cannot be removed from the project site until it is tested. This wet or dry waste material must be defined as a non-hazardous waste or hazardous waste.
- Wastewater (contaminated or otherwise) that is generated by wet abrasive blasting is to be considered as a Liquid Industrial Waste (LIW) under R.R.O 1990, Regulation 347 (O. Reg. 347) of the *Environmental Protection Act*. All wastewater must be contained in sealed containers and temporarily stored on the project site until it is collected for disposal by a licensed waste hauler.
- All off-site shipments of spent abrasives and wastewater must be accompanied by a MOECC waste manifest and the generator of the materials must be registered as a generator of hazardous waste with the MOECC. A Hazardous Waste Information Network (HWIN) number will be issued for the waste generator upon their registration with the MOECC, and this HWIN number must be used on all waste manifests.
- All other non-hazardous waste generated by abrasive blasting operations shall be disposed according to Ontario Regulation 558/00. R.R.O. 1990 (General – Waste Management).
- Environmental permits shall be obtained by the Contractor for any off-site disposal.

### *Related Environmental Standards and Guidelines*

- General Environmental Protection Procedures
- Fugitive Dust Control During Construction (ESG-8-C)

### *Related EMP Component Plans*

- Dust and Air Quality Management
- Noise, Vibration and Ambient Light Management
- Blasting
- Surface Water Management Erosion and Sediment Control
- Aquatic Resources Management
- Hazardous Materials Management

### *Other Design and Environmental Considerations*

- Timing of works should avoid seasonally high rainfall and snowmelt periods.

### *References*

Government of Newfoundland and Labrador, 1996. Environmental Code of Practice for Abrasive Blasting. Prepared by the Department of Environment and Labour, Industrial Environmental Engineering Division. March 1995. Revised June 1996. Available at:  
[http://www.ecc.gov.nl.ca/env\\_protection/abrasive\\_blasting.pdf](http://www.ecc.gov.nl.ca/env_protection/abrasive_blasting.pdf)

Nova Scotia Power, 2014. Contractor Environmental Requirements. Available at:  
<https://www.nspower.ca/site/media/Parent/Contractor%20Environmental%20Requirements.pdf>



# Blasting (ESG-2-C)

---

## Application to Ontario Waterways' Projects

Blasting on land is occasionally required during some construction projects when the removal of large quantities of rock is required. Blasting on land has the potential to result in adverse noise and vibration to local receptors including nearby residents and communities as well as wildlife. When conducted in proximity to Ontario Waterways, blasting also has the potential to harm or kill fish and adversely affect water quality. The use of explosives to remove quantities of rock is more likely to be associated with large scale PCA construction projects.

Blasting in or near waterbodies has the potential to disrupt or cause serious harm to fish. Uncontrolled or unmitigated blasting will adversely affect water quality. The proximity of PCA's assets to fish bearing waterbodies elevates the need to address these potential effects and adhere to strict standards and guidelines.

## Description of Activity

Blasting is the controlled use of explosives to clear or excavate large quantities of intact rock. Blasting produces noise and vibration shock waves that can adversely affect nearby wildlife and temporarily affect nearby residents and communities. Blasting in / or near water produces shock waves that can damage fish swim bladders and rupture their internal organs. Blasting vibrations may also kill or damage fish eggs or larvae. Chemicals harmful to aquatic life, including ammonia, can be released from the explosive into the water during blasting.

## Environmental Standards and Guidelines

- A construction and operation of a factory or a fixed site for the manufacture of blasting explosives shall be avoided. Explosives should be transported to the site and stored temporarily for use on-site.
- Blasting on land and in-water should be avoided. No blasting should occur within 300 m of known bat habitat features.
- Should blasting be required, a Blasting plan must be included in the site-specific EMP and accepted by PCA.
- The Blasting plan shall be developed by a Qualified Professional(s), in accordance with:
  - OPSS 120 General Specification for the Use of Explosives, including 120.04 Submission and Design Requirements.
  - "Guidelines for the use of Explosives In or Near Canadian Fisheries Waters" (DFO 1998) to reduce particle velocities and pressure changes created by underwater explosives that can result in fish injuries and mortality. This also includes the methods of small scare blasts and stacking of charges.
  - Canadian Standards Association Z107.54-M85 (R 1999) regarding procedure for measurement of sound and vibration due to blasting operations.
  - OPSS 120 General Specification for the Use of Explosives, including OPSS 120.07.04 Monitoring and address the following:
    - Ground vibration and the peak sound pressure level shall be monitored 100 m from the blast site or at the closest residence, utilities, structure, or facility within this radius during each blast.



- Water overpressure in affected fish habitats shall be monitored adjacent to the shore closest to the blast site.
- All blasting operations shall be undertaken under the supervision of a Qualified Professional.
- PCA shall be notified within 48 hours prior to the commencement of any blasting activities.

#### *Related Environmental Standards and Guidelines*

- General Environmental Protection Procedures
- Erosion Control (ESG-1-Pre)
- Sediment Control (ESG-2-Pre)
- Borehole and Rock Drilling (ESG-3-C)
- Fish Exclusion, Salvage and Relocation (ESG-7-C)

#### *Related EMP Component Plans*

- Dust and Air Quality Management
- Noise, Vibration and Ambient Light Management
- Blasting
- Demolition
- Surface Water Management Erosion and Sediment Control
- Vegetation Protection
- Wildlife Protection and Management
- Aquatic Resources Management
- Species at Risk Protection
- Hazardous Materials Management
- Fuel Management

#### *Other Design and Environmental Considerations*

- Timing windows for migratory birds and in-water works shall be respected.

#### *Further Guidance*

Ontario Provincial Standard Specification (OPSS) 120 - General Specification for the Use of Explosives  
Department of Fisheries and Oceans, 1998. Guidelines for the Use of Explosives In or Near Canadian Fisheries Waters.

Canadian Standards Association Z107.54-M85 (R 1999) Procedure for Measurement of Sound and Vibration Due to Blasting Operations.

#### *References*

British Columbia Ministry of Forests, Lands and Natural Resource Operations, 2014. A Compendium of Wildlife Guidelines for Industrial Development Projects in the North Area, British Columbia Interim Guidance, November 19 2014.

Gosse, M.M., A.S. Power, D.E. Hyslop, and S.L. Pierce. 1998. Guidelines for Protection of Freshwater Fish Habitat in Newfoundland and Labrador. Fisheries and Oceans, St. John's, NF. x + 105 pp., 2 appendices.





# Borehole and Rock Drilling (ESG-3-C)

---

## Application to Ontario Waterways' Projects

Borehole and rock drilling are occasionally required during some construction projects when there is a need to undertake geotechnical investigations to determine the physical properties of soil and rock in order to assist with the design earthworks and/or foundations for locks, dams and bridges. Borehole and rock drilling may also be required for the construction of anchors, coffer dam steel beams, the installation of ground water monitoring or dewatering wells. Borehole and rock drilling has the potential to result in adverse noise and vibration to local receptors including nearby residents and communities as well as wildlife. When conducted in water or in proximity to a waterway, borehole and rock drilling also has the potential to disturb or harm fish and adversely affect water quality.

## Description of Activity

There are several types of borehole and drilling methods. Diamond drilling produces cylindrical pieces of rock called core; reverse circulation or rotary drilling produces chips of rock; overburden drilling is conducted to sample overburden, and auger drilling is used most often to sample surficial soils for geotechnical purposes. Borehole and rock drilling can be conducted with small truck mounted or track mounted drill rigs or with larger fixed drill rigs. Drill rigs may also be employed on barges.

For most drilling activities, small areas of land must be cleared to make a drill pad or for access. It must be large enough for safe operation of the drill and other equipment. Some types of drilling, including diamond drilling, pump water to the drill and down the hole. The water pumps may be placed on the shores of lakes, rivers and streams. The water is pumped through heavy hoses to the drill rig.

## Environmental Standards and Guidelines

- Borehole and rock drilling shall conform to Parks Canada Agency's "BMP: Geotechnical Investigations (Bore-hole Drilling)" (2016).
- All borehole and rock drilling activities, including construction, operation and decommissioning shall be undertaken under the supervision of a Qualified Professional.
- The PCA Environmental Authority shall be contacted and advised at least fourteen (14) days in advance of the start of the proposed borehole or rock drill operations. All drilling locations will be identified on a map with GPS coordinates in the EMP. If borehole locations are moved greater than 3 m or are within 5 m of identified/know archaeological resources, PCA's Environmental Authority must review and accept changes.

## Drill Cuttings and Fluid Management

- Drill cuttings and fluids shall not be released into a wetland, watercourse or waterbody under any circumstances.
- If drilling fluids are required, only fresh water shall be used for fluid preparation. No toxic or hazardous substances are to be added to the drilling fluid at any time.
- All lubricants used on drill bits, casings or down-hole applications shall be free of any toxic or hazardous substances
- Recirculation pits or in-ground sumps shall be constructed (as surface conditions allow) to contain drilling mud, cuttings, treatment chemicals and discharged water from the drilling process. Drill cuttings recirculation tanks that capture cuttings will be required where sumps cannot be constructed, such as in bedrock.
- At the conclusion of drilling, sumps will be backfilled with clean soil materials, leveled and graded.



### Purged Groundwater and Drilling Wastes

- Groundwater (contaminated or otherwise) that has been purged/removed from groundwater monitoring wells is defined as a Liquid Industrial Waste (LIW) under R.R.O 1990, Regulation 347 (O. Reg. 347) of the *Environmental Protection Act*. All groundwater purged from monitoring wells must be contained in sealed containers and temporarily stored on the project site until it is collected for disposal by a licensed waste hauler.
- All off-site shipments of purged groundwater must be accompanied by a MOECC waste manifest and the generator of the purged groundwater must be registered as a generator of hazardous waste with the MOECC. A Hazardous Waste Information Network (HWIN) number will be issued for the waste generator upon their registration with the MOECC, and this HWIN number must be used on all waste manifests.
- All waste generated by drilling shall be disposed according to Ontario Regulation 558/00. R.R.O. 1990 (General – Waste Management)
- Environmental permits shall be obtained by the Contractor for any off-site disposal.

### Artesian or Flowing Wells

- Artesian or flowing wells must be controlled and constructed in accordance with Ontario Regulation 903 (Wells) as amended, made under the *Ontario Water Resources Act* which provides minimum construction requirements for the construction of a flowing well.

### Borehole or Well Decommissioning

- A borehole or well shall be abandoned if it is not being used or maintained for future use and decommissioned in accordance with Ontario Regulation 903 (Wells) as amended, made under the *Ontario Water Resources Act*.

### Related Environmental Standards and Guidelines

- General Environmental Protection Procedures
- Erosion Control (ESG-1-Pre)
- Sediment Control (ESG-2-Pre)
- Vegetation Clearing and Protection (ESG-5-Pre)
- Fugitive Dust Control During Construction (ESG-8-C)
- Refueling and Spill Management (ESG-13-C)
- Treatment of Discharge Waters (ESG-14-C)
- Use and Maintenance of Heavy Equipment (ESG-15-C)

### Related EMP Component Plans

- Dust and Air Quality Management
- Noise, Vibration and Ambient Light Management
- Site Dewatering and Wastewater Plan
- Surface Water Management, Erosion and Sediment Control
- Species at Risk Protection
- Fuel Management
- Spills Prevention and Emergency Response



### *Other Design and Environmental Considerations*

- Works are preferably undertaken during periods of dry weather (e.g., summer) as this allows easier control of sediment.
- Timing windows for in-water works shall be respected.

### *Further Guidance*

Parks Canada Agency, 2016. BMP: Geotechnical Investigations (Bore-hole Drilling), September, 2016.

*Ontario Water Resources Act*, R.R.O. 1990, Regulation 903. Wells.

*Ontario Protection Act*, R.R.O. 1990, Regulation 558/00. General – Waste Management.



# Chipping and Cutting (ESG-4-C)

---

## Application to Ontario Waterways' Projects

Projects involving repairs and upgrades to assets such as locks, bridges, retaining / approach walls and concrete dams often require the removal of concrete by chipping and cutting. Construction operations that involve chipping and cutting require special consideration because concrete is alkaline and highly toxic to fish and aquatic life. Concrete and concrete wastewater that contains suspended cement particles may increase the pH of water to a pH of 10 – 12. Concrete chipping and cutting also produces fine dust and sediment that is extremely difficult to remove once in suspension with water. Measures must be taken to prevent any incidence of concrete or concrete wastewater or leachate from entering a watercourse, either directly or indirectly.

## Description of Activity

Chipping typically involves breaking off small pieces of concrete from surfaces by chiseling and/or routing out cracks in concrete with a saw or angle grinder before filling with a repair material. Cutting involves scoring the concrete surface and/or slicing the concrete into pieces using a sharp, straight-edged tool (e.g., concrete saw). While chipping is primarily a dry operation undertaken on land, concrete cutting can be undertaken on land using water to wet the concrete surface and cutting tool and underwater. Both chipping and cutting of concrete results in rubble of various dimensions, from fine dust to large concrete slabs. Concrete cutting may also result in leachates and slurries or concrete pastes. Concrete pieces may contain internal or exposed materials (e.g., rebar, wood, rock)

## Environmental Standards and Guidelines

### General

- Chipping and cutting operations undertaken in the “dry” are preferred to operations using water or those conducted underwater.
- The work site involving chipping and cutting of concrete shall be isolated from the environment. The isolated work site should be sufficiently large to contain water run-off, residues and any waste material. Prior to commencement of the work, water, erosion and sediment control measures shall be installed to ensure that concrete debris, concrete fines, wash or contact water is not deposited directly or indirectly into any watercourse, stormwater drain, ditch or street gutter. Measures (e.g., sediment bags with or without the use of flocculants) must be tailored to capture very small fines. See Sediment Control ([ESG-2-Pre](#)).

### Dry Chipping and Cutting – Fugitive Dust Control

- Fugitive dust emissions from dry chipping and cutting operations shall be strictly controlled. See Abrasive Blasting ([ESG-1-C](#)).



### Wet Cutting – Water Management

- Use as little water as possible when wet cutting.
- Runoff water shall be collected by a wet industrial vacuum or suction pump and filtered into covered containers.
- Water from wet cutting operations shall be strictly controlled. The discharge of concrete leachate or slurries into a watercourse is prohibited. See Concrete Pour Operations and Grouting (ESG-5-C).

### Clean-up and Waste Management

- Concrete debris shall be placed into an enclosed container daily, or more frequently if required, in order to ensure that no debris escape or remain at the site.
- Washing of cutting or chipping tools and equipment in any body of water is prohibited. All cutting and chipping equipment must be washed in a wash down area. Any wash-down area location shall be identified and approved in the EMP. (See Concrete Pour Operations and Grouting (ESG-5-C)).
- All concrete debris shall be completely removed and area restored to original state upon completion of work.
- Concrete cutting leachates or slurries generated during chipping or cutting operations cannot be removed from the project site until tested. This waste material must be defined as a non-hazardous waste or hazardous waste.
- Leachates or slurries (contaminated or otherwise) that are generated by wet cutting with a pH  $\geq$  12.5 are considered corrosive and a hazardous waste under Ontario Regulation 347 of the *Environmental Protection Act*. All leachates and slurries must be contained in sealed containers and temporarily stored on the project site until they are collected for disposal by a licensed waste hauler.
- All off-site shipments of concrete cutting leachates or slurries must be accompanied by a MOECC waste manifest and the generator of the materials must be registered as a generator of hazardous waste with the MOECC. A Hazardous Waste Information Network (HWIN) number will be issued for the waste generator upon their registration with the MOECC, and this HWIN number must be used on all waste manifests.
- All other non-hazardous waste generated chipping or cutting operations shall be disposed according to Ontario Regulation 558/00. R.R.O. 1990 (General – Waste Management). Concrete debris that is considered to be inert should be diverted from landfill.
- Environmental permits shall be obtained by the Contractor for any off-site disposal.

### Environmental Performance and Monitoring

- Concrete leachate and slurries shall be routinely tested to confirm compliance with performance standards.
- Monitor pH frequently in the intake of discharge pump, holding tank, outflow of the isolated worksite until the works are completed. Corrective measures should be implemented if downstream water pH has changed more than 1.0 pH unit, measured to an accuracy of +/- 0.2 pH units from the background level, or is below 6.5 or above 9.0 pH units.



### *Related Environmental Standards and Guidelines*

- General Environmental Protection Procedures
- Erosion Control (ESG-1-Pre)
- Sediment Control (ESG-2-Pre)
- Concrete Pour Operations and Grouting (ESG-5-C)
- Treatment of Discharge Waters (ESG-14-C)

### *Related EMP Component Plans*

- Dust and Air Quality Management
- Noise, Vibration and Ambient Light Management
- Demolition
- Surface Water Management, Erosion and Sediment Removal

### *Other Design and Environmental Considerations*

- Works are preferably undertaken during periods of dry weather (e.g., summer) as this allows easier control of sediment.

### *References*

NSW Environmental Protection Authority, 2002. Environmental Management Best Practice Guideline for Concrete Contractors. ISBN 0-7347-7535-0, October 2002. Available at: [www.epa.nsw.gov.au](http://www.epa.nsw.gov.au).

VOI Training Group, 2014. Environmental Field Procedures for Works in and About Water. Developed by Van Osch Innovations Ltd., 130 Columbia Street, Nanaimo, British Columbia, Canada.



# Concrete Pour Operations and Grouting (ESG-5-C)

---

## Application to Ontario Waterways' Projects

Concrete dam replacement projects, and projects involving repairs and upgrades to assets such as locks, bridges, retaining / approach walls and concrete dams may require the pouring of concrete for foundations and/or for the main structure. Concrete pours underwater are undertaken by a special technique referred to as a "Tremie Pour". Grouting and sealing operations are also undertaken to seal a dam to its foundations, stabilize rock anchors. Sealants may also be used to seal concrete surfaces or infill cracks and joints in the concrete once poured.

Construction operations that involve concrete pours and grouting require special consideration because concrete and grouts are alkaline and highly toxic to fish and aquatic life. Concrete and concrete wastewater contains suspended cement particles which may increase to a pH of 10 – 12. Measures must be taken to prevent any incidence of concrete, wastewater or concrete leachate from entering a watercourse, either directly or indirectly.

## Description of Activity

Concrete pouring operations involve producing the desired concrete material either on-site or off-site, ensuring the concrete is properly mixed, placed into forms, shaped, and cured / set within time constraints. Cement pouring operations are strictly controlled to achieve its desired properties such as mechanical strength, low moisture permeability, and chemical and volumetric stability.

Tremie concrete is a special mix that allows the concrete to be placed underwater or into deep foundations. Tremie concrete has the ability to achieve full compaction by self-weight when placed by Tremie in a deep foundation, under submerged conditions. Underwater concreting using the Tremie method is convenient for pouring large amount of high flowable concrete. The concrete is moved to the hopper by either pumping, belt conveyer or skips. Tremie pipe, which upper end connected to a hopper and lower end continuously submerged in fresh concrete, is used to place concrete at the exact location from a hopper at the surface.

Any interruption in pouring of the concrete can cause the initially placed material to begin to set before the next batch is added on top. A wide variety of equipment is used for concrete pour operations, from hand tools to heavy industrial machinery (e.g., mixers, pumps). Concrete washout areas are typically used to contain concrete slurry and liquids when the chutes of concrete mixers and hoppers of concrete pumps are rinsed out after delivery to a site. The washout facilities are used to consolidate solids for easier disposal or reuse and to prevent runoff of contaminated liquids.

Grouting and sealing is carried out to fill cracks and voids in concrete and to fill voids partly occupied by several different types of materials (e.g., concrete, metal, rock, etc.). Cementitious grouts are most commonly applied in sealing of concrete, brick or rock structures. Chemical grouts (e.g., epoxy mixes, polyurethane) are used in smaller quantities for more specialized purposes. Equipment used in the application of cementitious grouting includes grout mixers, holding tanks with agitators, pumps and various grout applicators.



## *Environmental Standards and Guidelines*

### General

- All concrete pour operations must be described in the Construction Plan of the site-specific EMP and accepted by PCA.
- Use pre-cast concrete structures where feasible to minimize concrete pour operations.
- Works are preferably undertaken during periods of dry weather (e.g., summer) as this allows easier control of sediment.
- Concrete delivery routes and pump truck and/or concrete delivery system location(s) must be described in the site-specific EMP and accepted by PCA.
- Washing of concrete pouring, grouting and sealing tools and equipment in any body of water is prohibited. All concrete pouring, grouting and sealing equipment must be washed in a wash-down area.
- All wash-down area and containment facility locations must be identified in the site-specific EMP and accepted by PCA.
- All concrete products, grouts and sealants shall be stored under cover, away from watercourse, stormwater drains, ditches or street gutters
- Prior to commencement of the work, ensure water, and sediment control measures are designed to ensure that concrete is not deposited directly or indirectly into any watercourse, stormwater drain, ditch or street gutter.
- No excess concrete shall be deposited on-site.

### Normal Concrete Pour Operations

- PCA shall be notified within 48 hours prior to the commencement of any significant concrete pour operations (e.g., foundations) and for all Tremie pour operations.
- Maintain complete isolation of cast-in-place concrete for a minimum of 48 hours if the ambient air temperature is above 0°C (for the entire period) and for a minimum of 72 hours if ambient air temperature is below 0°C;
- All water that contacts uncured or partly cured concrete, all leachates or wastewater with high pH (greater than 9) shall be captured in a wastewater containment area.
- The waste water containment area shall be designed by a Qualified Professional(s) and sized to hold twice the volume of anticipated water run-off, leachate or wastewater.
- Carbon dioxide (CO<sub>2</sub>) or neutralizing acids shall be used to neutralize waters with high pH (greater than 9).
- Sufficiently sized carbon dioxide (CO<sub>2</sub>) tanks with regulators, hoses and gas diffuser, shall be readily available during normal concrete pour operations. The tank shall be used to release carbon dioxide gas into an affected area to neutralize pH levels should a concrete spill occur. Workers shall be trained in the use of the tank.
- Neutralizing acids must be contained in a professionally established system operated by a Qualified Professional.
- Any use of carbon dioxide (CO<sub>2</sub>) or neutralizing acids to modify pH levels shall be reported to PCA as soon as reasonably possible





### Tremie Pour Operations

- Tremie pour operations must be described in the Construction Plan of the site-specific EMP and accepted by PCA.
- Tremie pour operations may be undertaken where site conditions do not allow work in the “dry” and in still water or near zero flow conditions exist (i.e., <0.5 m/sec). Justification of the need for the Tremie pour operations must be included in the site-specific EMP.
- All Tremie pour equipment shall be operated from the shore.
- All forms shall be examined prior to concrete pours to ensure they are tight.
- The work area for a Tremie pour shall be isolated with a turbidity curtain (See Sediment Control ESG-2-Pre) and/or impermeable material (e.g., sheet piling, sandbags plus impermeable material to line sandbags).
- Carbon dioxide (CO<sub>2</sub>) shall be used to neutralize waters with high pH (greater than 9).
- Sufficiently sized carbon dioxide (CO<sub>2</sub>) tanks with regulators, hoses and gas diffuser, shall be readily available during normal concrete pour operations. The tank shall be used to release carbon dioxide gas into an affected area to neutralize pH levels should a concrete spill or seepage from the concrete form occur. Workers shall be trained in the use of the tank.
- Any use of carbon dioxide (CO<sub>2</sub>) to modify pH levels shall be reported to PCA as soon as reasonably possible
- The use of neutralizing acids to neutralize waters with high pH is prohibited at Tremie pour operations.

### Grouting and Sealing

- The type(s) of grouts and sealants proposed for use shall be identified in the site-specific EMP and accepted by PCA.
- Avoid mixing or ordering more grout and sealant material than is required to complete the work.
- Isolate the work site involving grouting to the extent possible. The isolated work site should be sufficiently large to contain water run-off, residues and any waste material.
- Store grout and sealant products under cover, away from watercourse, stormwater drains, ditches or street gutters.
- All grout and sealant products and excess materials shall be removed in a way that will ensure material does not enter the waterway, stormwater drain, ditch or street gutter. Collect excess grout in the “dry”.

### Wash-down Areas

- Provide appropriately sized containment facilities for the wash-down water from concrete delivery trucks, concrete pumping equipment.
- Containment structure area should be emptied/changed once 50% full.
- The wash-down area should be located away from a watercourse, stormwater drain, ditch or street gutter on flat even terrain.
- The wash-down area should be conveniently located for washing out equipment and clearly sign-posted.
- All wash-down water is to be contained.
- Concrete wash-down areas are generally not designed for the collection of excess concrete. Excess concrete waste should be returned to the local batching plant for treatment and re-use, or placed in a site receptacle designated for concrete and masonry, and allowed to set.
- To minimize the amount of wash-down water generated, excess concrete should be scraped off the equipment before it is washed and placed in a site receptacle designated for concrete.
- A high pressure, low volume water spray nozzle should be used to reduce water use.



### Spill Response Involving Wet Concrete

In situations where wet (fresh) concrete or partially mixed cementitious materials, or waste water are released from concrete pouring equipment (e.g., the mixer drum, pumper truck) or forms in an uncontrolled situation the following release response procedures should be followed:

- Concrete is considered a deleterious substance and must be reported to PCA and the Ontario Ministry of Environment and Climate Change Spills Action Centre (SAC).
- Maintain an on-site concrete spill response kit that includes:
  - Sand bags (number to match the scale of the project) and to isolate a contaminated area
  - Impermeable material to line sandbags
  - Impermeable turbidity curtains
  - CO<sub>2</sub> Bubblers
- Secure concrete spill area and establish access control.
- Safely contain the released material. Build berms using available on-site surface materials to contain the wet concrete or slurry. Berms constructed from low permeability material (e.g., clays) are preferred. Ensure the flow of wet concrete or slurry is prevented from entering any storm sewer opening, drainage ditch or water body.
- Depending on site conditions and area activities, let the wet concrete set, (usually within 75 to 120 minutes). Once set up, spilled concrete can be broken up using available equipment (e.g., loader, dozer or backhoe), loaded and trucked away for recycling or disposal. If the release occurs on bare ground, some surface soil may have to be removed.
- For slurry, collect into drums or plastic garbage cans if spill volume is less than one cubic meter. A vacuum truck is recommended for collecting any larger volumes of slurry.
- If the concrete spill occurs into a drainage ditch, use berms of low permeability materials and sandbags to contain the spilled concrete.
- If concrete is spilled in a watercourse or waterbody – deploy impermeable turbidity curtains to contain area. Once site is contained, install CO<sub>2</sub> bubbler and removed as much solid material as possible.
- Let the wet concrete set. When set, concrete can be recovered using available equipment (e.g., loader, dozer or backhoe), broken up and trucked away for recycling or disposal. All efforts must be made in recovery to avoid further disturbance of the bed, slopes or banks of the water body or watercourse. Isolation berms cannot be removed until pH has returned to background levels.
- Monitoring of water pH downstream of a worksite or discharge point shall be undertaken at 100 m, 200, and 400 m or as directed by PCA.

### Water Quality Monitoring

- All concrete pours in or near water must have a Qualified Professional(s) on-site to monitor downstream surface water turbidity and pH and assist in mitigating the effects of a concrete release.
- Water pH shall be monitored frequently in the intake of discharge pump, holding tank, outflow, and/or downstream of the isolated work site or discharge point until the works are completed. Monitoring of water downstream of a worksite or discharge point shall be undertaken at 100 m, 200, and 400 m or as directed by PCA. In addition, waters within the isolated work area for a Tremie pour operation shall be sampled.
- Water pH monitoring must be conducted by a Qualified Professional(s) using a digital pH meter with an accuracy of +/- 0.2 pH units.
- Corrective measures shall be implemented if downstream pH has changed more than 1.0 pH unit from background, measured to an accuracy of +/- 0.2 pH units, or is below 6.5 or above 9.0 pH units.



### Waste and Wastewater Management

- The discharge of concrete wastewater, leachate or slurries into a watercourse is prohibited.
- Should the amount of water in the Tremie pour work site exceed the amount that the Tremie pour is able to handle, the excess water and any leachate will be pumped and contained in covered containers with appropriate visible labels and tested. Waters and leachates (contaminated or otherwise) that are generated by a concrete pour operation with a pH  $\geq$  12.5 are considered corrosive and a hazardous waste under Ontario Regulation 347 of the *Environmental Protection Act*. All wastewater, leachates and slurries must be contained in sealed containers and temporarily stored on the project site until they are collected for disposal by a licensed waste hauler.
- All off-site shipments must be accompanied by a MOECC waste manifest and the generator of the materials must be registered as a generator of hazardous waste with the MOECC. A Hazardous Waste Information Network (HWIN) number will be issued for the waste generator upon their registration with the MOECC, and this HWIN number must be used on all waste manifests.
- All other non-hazardous waste generated by a concrete pour operation shall be disposed according to Ontario Regulation 558/00. R.R.O. 1990 (General – Waste Management).
- Environmental permits shall be obtained by the Contractor for any off-site disposal.

### *Related Environmental Standards and Guidelines*

- General Environmental Protection Procedures
- Erosion Control (ESG-1-Pre)
- Sediment Control (ESG-2-Pre)
- Treatment of Discharge Waters (ESG-14-C)

### *Related EMP Component Plans*

- Transportation Management
- Site Dewatering and Wastewater Plan
- Surface Water Management, Erosion and Sediment Control
- Dredging and Sediment Removal
- Hazardous Materials Management
- Spill Prevention and Emergency Response

### *Other Design and Environmental Considerations*

- Confirm need /exemption for a PTTW based on volume and duration of removals and the requirement of a Historic Canals Regulations permit. Planning must allow sufficient time to obtain a permit from the MOECC/PCA.
- Grouting operations to be undertaken when ambient temperature falls below 4.4°C require special design considerations regarding the selection of masonry materials for cold weather performance need to protect and/or heat materials, water requirements, etc.)



## *References*

Canadian Ready Mixed Concrete Association, CRMCA, 2014. Recommended Guideline for Environmental Management Practices for the Canadian Ready Mixed Concrete Industry. May, 2004. Available at <https://3qcake159kca33qhh23so84g-wpengine.netdna-ssl.com/wp-content/uploads/2014/09/CRMCA-EMP-MAY-04.pdf>

Ontario Waterpower Association, 2012. Best Management Practices Guide for the Mitigation of Impacts of Waterpower Facility Construction. Version 1, June 2012.

NSW Environmental Protection Authority, 2002. Environmental Management Best Practice Guideline for Concrete Contractors. ISBN o-7347-7535-0, October 2002. [www.epa.nsw.gov.au](http://www.epa.nsw.gov.au).

NSW Government, 2015. Concrete Washout Guideline. Document 3TP-SD-112/2.0. Available at: <http://www.transport.nsw.gov.au/sites/default/files/b2b/projects/Concrete%20Washout%20Guideline%20-%203TP-SD-112.pdf>

Portland Cement Association, 2008. Cold Weather Masonry Construction. Available at: [http://www.cement.org/docs/default-source/fc\\_mat-app\\_pdfs/masonry/is248-cold-weather-masonry-construction.pdf?sfvrsn=4](http://www.cement.org/docs/default-source/fc_mat-app_pdfs/masonry/is248-cold-weather-masonry-construction.pdf?sfvrsn=4)

VOI Training Group, 2014. Environmental Field Procedures for Works in and About Water. Developed by Van Osch Innovations Ltd., 130 Columbia Street, Nanaimo, British Columbia, Canada.



# Dredging and Sediment Removal (ESG-6-C)

---

## Application to Ontario Waterways' Projects

Dredging and sediment removal is occasionally undertaken in waterways to facilitate construction, for facility maintenance and/or navigation purposes. Pre-dredging to remove soil or soft sediments may be undertaken in conjunction with cofferdam installation, and dredging is often used to remove sediment from behind a cofferdam or for site restoration. Dredging and sediment removal have the potential to harm or kill benthic organisms and fish. Water quality can be adversely affected through the resuspension of sediment.

## Description of Activity

Dredging and sediment removal refers to the removal of sediment from areas where sediment has accumulated over time (e.g., channel beds, water intakes, beneath boat slips / dock areas, locks and dams). Dredging and sediment removal can be undertaken using a variety of equipment, including mechanical dredges (e.g., buckets, clamshells, dippers); hydraulic or suction dredges (e.g., cutter head, auger head); and/or using speciality equipment and methods (e.g., water injection, or "jetsed", pneuma pumps and precision dredging tools).

## Environmental Standards and Guidelines

### General

- All sediment removal should be considered in the "dry" as the primary option. Where sediment removal in the "dry" is not feasible then dredging can be undertaken.
- All dredging activities shall be undertaken under the supervision of a Qualified Professional(s).
- Timing windows for in-water works shall be respected for dredging and sediment removal activities.
- The area(s) and volumes to be dredged, the dewatering method, equipment and operational controls to be used shall be outlined in a Dredging and Sediment Removal Plan to be reviewed and accepted by PCA prior to commencement of these activities.
- The PCA Environmental Authority shall be contacted and advised at least 48 hours in advance of the start of the proposed dredging or sediment removal operations if the activity has been previously assessed in the EIA.

### Dredging Operations

- Hydraulic or suction dredging will be the preferred method for sediment removal. Where contaminated sediments exist there is a potential for contaminated sediments, hydraulic or suction dredging is the only acceptable method for sediment removal. Refer to the Canadian Sediment Quality Guidelines for the Protection of Aquatic Life (CCME, 2001).
- Dredging operations shall be conducted from the shore or from an existing structure (e.g., berm, dam) where possible.
- If necessary, dredging and sediment removal may be conducted from a floating structure (i.e., a barge). In addition:
  - sufficient water must be present to prevent the barge from grounding;
  - minimize the use of barge stabilizing spuds and their disturbance of bottom substrates;
  - fully restore any areas disturbed by barge stabilizing spuds;
  - prop scour must not occur from tending vessel(s). This may require maneuvering of barges in shallow water with ropes tied to shore and/or pilings;



- exclude fish and other wildlife from the work area prior to the commencement of any pile driving operations;
- All boats and equipment used in pile driving operations will be cleaned off-site before coming onto the project site and before leaving the project site; and
- Boats shall be free of ballast water.
- Turbidity curtains shall be deployed around the dredge area for water depths greater than 0.5 m above the sediment bed. Turbidity curtains are ineffective at depths greater than 6 m and at current velocities greater than 0.5 m/sec (approx. 1 knot). Where turbidity curtains cannot be deployed then suction dredging or alternatives that minimize re-suspension of sediments will be used.
- Dredging operations shall be monitored using a Global Positioning System (GPS) tracking device to maintain dredging within the designated area(s).

#### Dewatering

- The pumping of turbid water directly back into the waterbody is not permitted. Downstream waters shall be routinely tested and compared to background to confirm compliance with performance standards. The field measurement for turbidity will be in NTU.
  - At the discharge points of pumping into any waterbody, a maximum increase of 8 NTU from background levels within 100 m of the dredge area for a short-term exposure (i.e., less than 24 hours). Maximum average increase of 2 NTU from background levels for a longer term exposure (e.g., more than 30 days). Should there be exceedances the PCA Environmental Authority may analyze Suspended Solids (SS) concentration with laboratory samples. When this occurs, TSS samples should be taken upstream of the work area (background), within the work area, and 100 m downstream of the dredge area. Additional downstream samples may be required by PCA.
  - At the discharge points of pumping into any waterbody, a maximum increase of suspended sediment concentration shall not be more than 25 mg/L over background levels within 100 m of the dredge area during any short term exposure period (i.e., less than 24 hours). For longer term operations (i.e., more than 30 days), average suspended sediment concentrations shall not be increased by more than 5 mg/L over background levels. TSS (mg/L) is only acceptable from laboratory results and will only be used if there is exceedances and for potential enforcement action.

#### Dredged Material Management

- No dredged materials shall be stored or stockpiled on top of ice during winter operations or where turbidity can run off-site and contaminate surrounding waterbodies.
- Any dredged material must have a suitable holding area designed to contain the volume of anticipated removal in a containment area or trucked off-site immediately.
- Dredged materials shall not be disposed of in a waterbody. Dredged materials shall be disposed in an approved Confined Disposal Facility (CDF) or licensed landfill.
- Storage of dredged material shall be managed and contained in accordance with PCA Sediment and Erosion and Sediment Control standards and guidelines.

#### Restoration

- Prior to re-watering, site must meet navigation depth requirements (these are site specific). All materials shall be removed and the dredge site restored.



### *Related Environmental Standards and Guidelines*

- General Environmental Protection Procedures
- Erosion Control (ESG-1-Pre)
- Sediment Control (ESG-2-Pre)
- Fish Exclusion, Salvage and Relocation (ESG-7-C)
- Installation and Removal of Cofferdams and Isolation Structures (ESG-10-C)
- Invasive Species Management (ESG-11-C)
- Refueling and Spill Management (ESG-13-C)
- Treatment of Discharge Waters (ESG-14-C)
- Use and Maintenance of Heavy Equipment (ESG-15-C)
- Vehicle and Equipment Washing and Cleaning (ESG-16-C)
- Wildlife and Species at Risk Protection During Construction (ESG-17-C)

### *Related EMP Component Plans*

- Dust and Air Quality Management
- Noise, Vibration and Ambient Light Management
- Transportation Management
- Demolition
- Site Dewatering and Wastewater Plan
- Surface Water Management, Erosion and Sediment Control
- Dredging and Sediment Removal
- Vegetation Protection
- Aquatic Resources Management
- Species at Risk Protection
- Fuel Management
- Spills Prevention and Emergency Response
- Dam and/or Bypass Channel Commissioning

### *Other Design and Environmental Considerations*

- Design and locate new structures to avoid the need for future maintenance dredging.

### *Further Guidance*

Parks Canada Agency, 2013. Parks Canada EIA - Best Management Practice for Routine Maintenance Dredging: Trent-Severn Waterway and Rideau Canal National Historic Sites. August, 2013.

Canadian Council of Ministers of the Environment (CCME), 2001. Canadian Environmental Quality Guidelines - Canadian Sediment Quality Guidelines for the Protection of Aquatic Life. Available at: <http://cegg-rcqe.ccme.ca>

### *References*

British Columbia Ministry of Environment, General BMPs and Standard Project Considerations - Standards and Best Practices for Instream Works. Available at: <http://www.env.gov.bc.ca/wld/instreamworks/downloads/GeneralBMPs.pdf>



# Fish Exclusion, Salvage and Relocation (ESG-7-C)

---

## Application to Ontario Waterways' Projects

In-water works often require partial isolation of work areas to perform construction and maintenance activities in the “dry”. The installation of the isolation structures like (coffer dams, turbidity curtains), coupled with dewatering operations, may result in stranded fish in the work areas to be dewatered and will require that measures are taken for fish exclusion, salvage and relocation.

## Description of Activity

Fish exclusion measures are those that prevent fish from entering or re-entering the working area. Fish exclusion involves deploying netting and “sweeping” the areas to drive fish out of the work area or into the netted area for capture. Fish salvage means the physical, non-lethal, capture of fish using other gear such as netting and electrofishing. Fish relocation involves moving the salvaged fish from the work area to either storage in buckets and tanks or directly to another location for release.

## Environmental Standards and Guidelines

### General

- Fish exclusion, salvage and relocation procedures and equipment shall be outlined in the site-specific EMP and accepted by PCA.
- All fish exclusion, salvage and relocation operations must be completed by a Qualified Professional(s) typically supported by a trained team.

### Work Site Isolation

- In low flow settings (<0.5 m/sec), deploy turbidity curtains around the perimeter of the work site unless work area is isolated using impermeable materials (coffer dam, sheet pile, etc.). See Sediment Control ([ESG-2-Pre](#)) for guidance regarding turbidity curtain installation. If using a net instead of a turbidity curtain, the mesh size must be sized according to the smallest fish expected.
- In high flow conditions, where turbidity curtains will be ineffective, low turbidity isolation structures (e.g., low berms constructed from lined sandbags) shall be used as an exclusion structure.

### Fish Salvage

- Perform an initial sweep of the work area to drive fish out prior to completely closing off the turbidity curtains surrounding the work area.
- Collect fish using gear suitable for the project site, habitat complexity, fish species likely to be encountered (particularly Species at Risk), and fish activity as determined by the Qualified Professional(s). Typical gear includes seine nets, dip nets, enmeshing nets and fish traps, and/or electrofishing. Other equipment includes buckets, holding tanks, fish transportation tanks. A combination of methods will usually be required. Electrofishing as a fish salvage method will be employed only if other salvage methods prove unsuccessful.
- Salvage should occur at water depths <0.5 m or depths that are most effective for the method chosen (e.g., boat e-fishing vs. seine netting).





- Initial fish salvage must continue until a rate of decline in the catch from subsequent efforts is observed and only a few individuals are caught.
  - A minimum of three (3) passes is recommended. Larger work areas and salvage undertaken at greater depths will require more passes.
  - Fish traps (bated or unbaited) must be deployed for a minimum of 24 hours. More traps (typically more than two) are required for larger work areas.
- Following initial salvage operations, the presence of residual fish should be anticipated. Additional efforts to safely remove stranded individuals should continue until dewatering activities are complete.
- An Inventory of captured fish numbers, species caught and mortality in accordance with permit conditions shall be prepared and submitted to PCA within one week of the completion of salvage operations.
- Any substantial mortality event (greater than 2%) shall be reported immediately to PCA.
- Release live fish into the same waterbody at the location of the salvaging of the work area (i.e., upstream fish go upstream and downstream go downstream)
- If invasive species are caught, fish will be euthanized and disposed of according to Canadian Council on Animal Care's "Guidelines on The Care and Use of Fish in Research, Teaching and Testing".
- Any fish exclusion method including turbidity curtains must be monitored for the duration of in water works. If fish are observed within the exclusion area, barriers must be reinstalled and fish salvage must reoccur.

#### Fish Handling Guidelines

- Fish must be handled as little as possible while collecting and transferring them into buckets, holding tanks or safety pools.
- Fish shall be transferred immediately to either a safe upstream or downstream area (15 min max holding time).
- Live tanks fitted with aeration bubblers must be used for larger capture operations where numerous (i.e., thousands) fish or sensitive coldwater species are anticipated. Fish should not be crowded in the holding containers. Fish will be less stressed in larger containers (300 gallons or larger preferred), in colder water, and with supplemental oxygen or aeration.
- Fish should be carefully released into the watercourse. Buckets will be submersed and fish allowed to swim out under their own power.
- The water temperature in the holding tanks will not be substantially (within 1-2 C<sup>o</sup>) different from the river water.

#### Related Environmental Standards and Guidelines

- General Environmental Protection Procedures
- Erosion Control (ESG-1-Pre)
- Sediment Control (ESG-2-Pre)
- Installation and Removal of Cofferdams and Isolation Structures (ESG-10-C)
- Treatment of Discharge Waters (ESG-14-C)
- Wildlife and Species at Risk Protection During Construction (ESG-17-C)



### *Related EMP Component Plans*

- Blasting
- Site Dewatering and Wastewater Management
- Surface Water Management, Erosion and Sediment Control
- Dredging and Sediment Removal
- Aquatic Resources Management
- Species at Risk Protection
- Invasive Species Management
- Spills Prevention and Emergency Response
- Dam and/or Bypass Channel Commissioning
- Site Restoration

### *Other Design and Environmental Considerations*

- None

### *Further Guidance*

Canadian Council on Animal Care, 2005. Guidelines on The Care and Use of Fish in Research, Teaching and Testing. ISBN: 0-919087-43-4. Available at: <http://www.ccac.ca>.

### *References*

British Columbia Ministry of Agriculture, Food and Fisheries, 2005. Drainage Management Guide – No. 17 in series order No. 527.110.1 – Fish Salvage. April, 2005.

Washington State Department of Transportation (WSDOT), undated. WSDOT Fish Exclusion Protocols and Standards. Available at: [https://www.wsdot.wa.gov/NR/rdonlyres/70E7E285-ECC6-41BA-A2DF-87FD0D68128D/0/BA\\_FishHandling.pdf](https://www.wsdot.wa.gov/NR/rdonlyres/70E7E285-ECC6-41BA-A2DF-87FD0D68128D/0/BA_FishHandling.pdf)



# Fugitive Dust Control during Construction (ESG-8-C)

---

## Application to Ontario Waterways' Projects

Site preparation, construction and site restoration activities undertaken for projects on Ontario Waterways such as earthworks, excavation, soil stripping, clearing and grubbing, earthmoving and revegetation, can result in significant dust emissions, especially during dry weather periods and particularly if followed by high winds.

## Description of Activity

Water or chemical dust suppressants can be applied to mitigate fugitive dust from site preparation and construction activities. The application of water is typically the most common and preferred by PCA dust control method that is employed by construction companies across Canada. A variety of chemical dust suppressants are available to suppress fugitive dust emissions from construction sites.

## Environmental Standards and Guidelines

### General

- All fugitive dust control measures must be described in the site-specific EMP and accepted by PCA, including all proposed chemical applications for dust control.
- Use of salts or petroleum products for dust control is prohibited.
- Fugitive dust levels, measured as total suspended particulate (TSP) at the property boundary shall not exceed the Ontario Ambient Air Quality Criteria (AAQC) of 120 micrograms per cubic metre ( $\mu\text{g}/\text{m}^3$ ) over 24 hours or  $60 \mu\text{g}/\text{m}^3$  averaged over a year. For measuring methods, refer to the Canada-wide Standards for Particulate Matter and Ozone Ambient Air Monitoring Protocol.

The following best practices for the management of construction sites shall be considered in developing a Dust and Air Quality Management Plan as part of the site specific EMP.

### Site Preparation

The first principle in minimizing fugitive dust is to follow erosion control best practices (See Erosion Control ([ESG-1-Pre](#))).

- Clear and grade the construction site in stages
- Maintain vegetative buffers as wind screens and utilize wind fencing
- Stabilize surfaces of completed earthworks
- Prohibit open burning
- Where possible, reduce earthworks during windy conditions.

### Storage Piles

- Locate storage piles in sheltered areas
- Utilize enclosures/coverings for storage piles where feasible
- Utilize wind fences/screens for storage piles in addition to sediment fencing.



- Stabilize short term and long term stockpiles (See Soil Stripping, Grubbing and Stockpiling, [ESG-3-Pre](#))

#### Material Handling and Transfer Systems

- Establish stabilized work site entrances (See Sediment Control [ESG-2-Pre](#))
- Secure loads on haul trucks. Total enclosures are preferred to partial enclosures
- Minimize material handling
- Where possible, reduce certain material handling activities during windy conditions

#### Using Water and Chemical Dust Suppressants at Construction Sites

- The use of water as a dust suppressant is preferred to then use of chemical agents.
- Water should be applied, at a minimum, once a daily basis, to all inactive disturbed areas, unpaved roads used for vehicular traffic and active storage or stockpiles. The frequency of application should be increased beyond once per day to prevent visible emissions of fugitive dust. Consideration should be given to spraying water onto materials with the potential to generate dust 15 minutes prior to handling and/or at points of transfer.
- Water will not be applied in volumes capable of creating erosion or uncontrolled run-off.
- Only approved chemical agents, accepted by PCA, can be applied as dust suppressants. The categories of products for dust suppression include:
  - Lignin derivatives (e.g., Tembec's Tembind or TDS)
  - Vegetable oils (canola, soybean, linseed, etc.)
  - Synthetic polymer emulsions
- Products that have not been accepted by PCA must undergo an assessment before being accepted for use as a dust suppressant.
- Application of chemical agents must follow manufacturer's specifications.

#### *Related Environmental Standards and Guidelines*

- General Environmental Protection Procedures
- Erosion Control ([ESG-1-Pre](#))
- Sediment Control ([ESG-2-Pre](#))
- Soil Stripping, Grubbing and Stockpiling ([ESG-3-Pre](#))

#### *Related EMP Component Plans*

- Dust and Air Quality Management
- Noise, Vibration and Ambient Light Management
- Blasting
- Vegetation Protection
- Wildlife Protection and Management
- Aquatic Resources Management
- Species at Risk Protection



### *Other Design and Environmental Considerations*

- A variety of chemical dust suppressants are available to suppress fugitive dust emissions from construction sites. While being more expensive than water, they are also more effective in suppressing dust and have to be applied much less frequently.
- MSDS sheets or equivalent data for chemical dust suppressants should be available on-site.

### *Further Guidance*

Canadian Council of Ministers of the Environment (CCME). (2011). Ambient Air Monitoring Protocol for PM<sub>2.5</sub> and Ozone – Canada –wide Standards for Particulate Matter and Ozone. PN 1456. Available at: [http://www.ccme.ca/files/Resources/air/pm\\_ozone/pm\\_oz\\_cws\\_monitoring\\_protocol\\_pn1456\\_e.pdf](http://www.ccme.ca/files/Resources/air/pm_ozone/pm_oz_cws_monitoring_protocol_pn1456_e.pdf)

### *References*

Centre for Excellence in Mining Innovation (CEMI), 2010. Literature Review of Current Fugitive Dust Control Practices within the Mining Industry. Prepared by Golder Associates, August 11, 2010.

Cheminfo, 2005. Best Practices for the Reduction of Air Emissions from Construction and Demolition Activities. Report prepared for Environment Canada, March 2005.

Federation of Canadian Municipalities and National Research Council, 2005. Dust Control for Unpaved Roads. Version 1.0. October, 2005. ISBN 1-897094-93-0. Available at: [https://www.fcm.ca/Documents/reports/Infraguide/Dust\\_Control\\_for\\_Unpaved\\_Roads\\_EN.pdf](https://www.fcm.ca/Documents/reports/Infraguide/Dust_Control_for_Unpaved_Roads_EN.pdf)

Ontario Ministry of Environment, 2012. Ontario's Ambient Air Quality Criteria. Standards Development Branch, Ontario Ministry of the Environment, April 2012. PIBS#6570e01.

Provincial / Territorial Committee (PTOC) on Local Government, 2016. Dust Suppression Alternatives – 2016 Update. June 2016.



# Grinding and Welding (ESG-9-C)

---

## Application to Ontario Waterways' Projects

Grinding and welding operations are anticipated for projects on Ontario Waterways involving placement of steel and structural steel for locks, gates, building super-structure, the fabrication, installation, dismantling of mechanical equipment (HVAC equipment) and ancillary equipment such as handrails, guardrails, specialties, and ornamental metal.

## Description of Activity

Grinding and welding are processes used to cut or join metal using heat. Operations such as welding and grinding, or similar, are capable of igniting combustible materials or flammable atmospheres or providing a source of ignition for a fire. They involve the use of portable compressed gas cylinders, arc welding equipment, open flame or spark-producing equipment. Compressed gas cylinders have inherent dangers. The handling and storage of compressed gas cylinders must be undertaken with great care. Grinding and welding operations on land are undertaken with shielding such as non-combustible welding drapes, used in hot work areas.

Grinding and welding can also be undertaken underwater by trained divers. Underwater grinding and welding operations involve several hazards, including lethal electrical currents and the use of oxygen and hydrogen rich gases which can explode.

## Environmental Standards and Guidelines

- Land-based or grinding and welding activities conducted in the “dry” are preferred to underwater grinding and welding.

### Land-based Grinding and Welding

- All land based grinding and welding activities must be conducted in a manner as to prevent release of weld rods, metal chips, or any other debris into a stormwater drain, waterbody or watercourse.
- Undertake grinding and welding activities indoors or off-site where possible and comply with health & safety, technical and waste management specifications. Ensure designated substance report is followed (if applicable).
- Fit grinders and other power tools with dust extraction and collection systems.
- Establish an isolated, well-ventilated area for using oxy-acetylene torches and welders, away from combustible materials such as fuels, oils, grease and rubber.
- Conduct all grinding operations on a sealed surface inside a screened area to minimize the dispersion of metal fragments
- Schedule outdoor grinding and welding activities for dry weather. Do not conduct outdoor grinding and welding activities during a rain event.
- Daily records must be maintained of all weld rods consumed.
- Metal scraps, filings and waste/unusable weld rods shall be stored in a container identified for scrap metal recycling.



### Underwater Grinding and Welding

- All underwater grinding or welding activities must be described in the site-specific EMP and accepted by PCA, including:
  - all chemicals and gases to be used underwater;
  - Procedures for the containment or otherwise collection / retrieval of metal scraps, filings and waste/unusable weld rods from the underwater work area.
- Underwater grinding and welding operations shall only be undertaken in still or extremely low flow conditions.
- Underwater grinding and welding operations shall be undertaken by a Qualified Professional(s).
- Daily records must be maintained of all weld rods consumed.
- Metal scraps, filings and waste/unusable weld rods shall be stored in a container identified for scrap metal recycling.

### Waste Management

- Wastes that are generated by grinding and welding operations that are considered to be hazardous wastes under Ontario Regulation 347 of the *Environmental Protection Act* must be contained in sealed containers and temporarily stored on the project site until they are collected for disposal by a licensed waste hauler.
- All other non-hazardous waste generated by a concrete pour operation shall be disposed according to Ontario Regulation 558/00. R.R.O. 1990 (General – Waste Management).
- Environmental permits shall be obtained by the Contractor for any off-site disposal.

### Related Environmental Standards and Guidelines

- General Environmental Protection Procedures
- Fugitive Dust Control During Construction (ESG-8-C)
- Refueling and Spill Management (ESG-13-C)

### Related EMP Component Plans

- Dust and Air Quality Management
- Noise, Vibration and Ambient Light Management
- Demolition
- Fuel Management
- Hazardous Materials Management
- Spills Prevention and Emergency Response
- Dam and/or Bypass Channel Commissioning

### Other Design and Environmental Considerations

- None

### References

Centre for Environmental Excellence, 2017. Construction Practices for Environmental Stewardship. [http://environment.transportation.org/environmental\\_issues/construct\\_maint\\_prac/compendium/manual/detailed\\_toc.aspx](http://environment.transportation.org/environmental_issues/construct_maint_prac/compendium/manual/detailed_toc.aspx)



# Installation and Removal of Cofferdams and Isolation Structures (ESG-10-C)

---

## Application to Ontario Waterways' Projects

In-water works often require partial isolation of work areas to perform construction and maintenance activities in the “dry”. In some instances, this may require the maintenance of downstream flow and fish passage using a coffer dam. Cofferdams may be used for larger scale projects (e.g., dam replacements) and smaller scale projects such as maintenance, minor upgrades and repairs.

## Description of Activity

The use of a coffer dam involves isolating a portion of a water body to create a dry work area. In channels this involves isolating the work area from the active flow and dewatering the created isolated work area. Cofferdams are also used in static waterbodies such as lakes to isolate piers or retaining walls. This isolation technique is generally considered a “passive” method, only requiring periodic removal of water from the work area using a small pump and hose following precipitation events or minor seep inflow. Due to the passive nature of this technique, its use should be encouraged during all operations having an anticipated duration of more than one week on appropriate sized waterbodies.

## Environmental Standards and Guidelines

- To the extent possible, all in-water work shall be conducted in the “dry” by using an isolation coffer dam.
- All coffer dam designs, installation and removal procedures, including timing, shall be described in the site-specific EMP and accepted by PCA.
- Cofferdams shall be designed by a Qualified Professional(s), taking into consideration the following best practices:

**Sizing** It is essential to use an adequately sized coffer dam in order to prevent overtopping during high flow events. A coffer dam shall be sized to isolate a specified portion of a channel during discharge events up to bankfull or the 1 in 20 year return flow, per year of construction. Frequent over-topping or persistent leaks requiring repeated dewatering of the work area shall not be permitted.

**Materials**

- It is essential that the most appropriate type of material be selected to construct a coffer dam. The preferred method is to use sheet steel, prefabricated inflatable rubber dam, meter bags filled with washed stone with a waterproof liner, or a form dam. See Pile Driving ([ESG-12-C](#)) for guidance regarding installation of sheet piling.
- For larger coffer dams, cellular structures containing aggregate shall be used.
- The placement of loose aggregate into a waterbody shall not be permitted.





- Dewatering
- A “clean water zone” on the inside of the coffer dam shall be established to keep water from leaking into the work area.
  - Dewatering of the work area requires the use of a pump. Clean water may be pumped directly into the active portion of the water body if no scour potential exists. The pumping of turbid water directly back into the waterbody is not permitted. Pumping operations shall ensure that the pump inlet(s) is protected using an appropriately designed and sized fixed screen or other device to prevent debris blockage and fish entrainment.
  - Screens may need to be designed and fabricated to be “fit for purpose”. See Treatment of Discharge Waters ([ESG-14-C](#)).
  - Periodic removal of water from behind the coffer dam may be required following precipitation events or minor seep inflow to keep the work area dry.
- Fish Salvage and Relocation
- Fish from within the isolated work area shall be salvaged and relocated. See Fish Exclusion, Salvage and Relocation ([ESG-7-C](#)).
  - In the event that the coffer dam is overtopped and inundated with water from the surrounding waterbody, fish shall be removed from the work area prior to de-watering.
- Dam Removal
- Following completion of works, the coffer dam shall be carefully removed from the waterbody so as to avoid disturbance of the bed and banks. Removal shall begin at the downstream end of a coffer dam in flowing water.

#### *Related Environmental Standards and Guidelines*

- General Environmental Protection Procedures
- Erosion Control ([ESG-1-Pre](#))
- Sediment Control ([ESG-2-Pre](#))
- Fish Exclusion, Salvage and Relocation ([ESG-7-C](#))
- Treatment of Discharge Waters ([ESG-14-C](#))

#### *Related EMP Component Plans*

- Dust and Air Quality Management
- Noise, Vibration and Ambient Light Management
- Blasting
- Demolition
- Site Dewatering and Wastewater Plan
- Surface Water Management, Erosion and Sediment Control
- Dredging and Sediment Removal
- Vegetation Protection
- Wildlife Protection and Management
- Aquatic Resources Management
- Species at Risk Protection
- Invasive Species Management
- Fuel Management
- Spills Prevention and Emergency Response
- Dam and/or Bypass Channel Commissioning



### *Other Design and Environmental Considerations*

- Confirm need /exemption for a PTTW based on volume and duration of removals and the requirement of a Historic Canals Regulations permit. Planning must allow sufficient time to obtain a permit from the MOECC/PCA.
- Timing of works should avoid seasonally high rainfall and snowmelt periods.
- Timing windows for in-water works shall be respected.

### *Further Guidance*

Department of Fisheries and Oceans (DFO), 1995. Freshwater Intake End-of-Pipe Fish Screen Guideline. ISBN 0-662-23168-6. Catalogue No. Fs 23-270 / 1995E.



# Invasive Species Management (ESG-11-C)

---

## Application to Ontario Waterways' Projects

There are a number of invasive species at properties along Ontario waterways sites that are currently being managed by PCA. Invasive species can be both plants, animals, fungi and/or viruses (e.g., dog strangling vine, water flea, butternut canker, snake fungal disease).

Construction activity requires numerous types of vehicles, boats and equipment, such as: passenger cars and trucks, motorbikes, all terrain Vehicles (ATV's), snowmobiles, boats and heavy equipment (e.g., trucks, tractors, backhoes, graders, dozers, excavators, skidders, loaders, cement pumpers, water tankers and trucks). The transport and operation of these vehicles, boats and equipment has the potential to introduce invasive species into areas of native vegetation and non-infested waters. Similarly, the disturbance of soils, stockpiling, moving impacted soils, water, wood, mulch and compost can result in the spread of invasive species across a site.

## Description of Activity

Activities associated with the clearing, construction, and restoration could introduce and accelerate the spread of invasive plants. Avoiding and/or reducing the introduction and spread of invasive species during construction activity is desirable for the protection of native vegetation and wildlife habitat. The term invasive plant species includes plants listed as weeds and/or noxious listed by the Ontario Ministry of Agriculture, Food and Rural Affairs. The most current list is available at: [http://www.omafra.gov.on.ca/english/crops/facts/noxious\\_weeds.htm](http://www.omafra.gov.on.ca/english/crops/facts/noxious_weeds.htm)

## Environmental Standards and Guidelines

### General

- Management or control plans to address invasive species infestations identified on-site and those highlighted in the EIA will be included in the site-specific EMP to be accepted by PCA.
- Any new invasive species identified will be reported to PCA and a management plan shall be developed and accepted by PCA.
- Management or control plans for invasive species infestations will be developed by a Qualified Professional(s).

### Preventive Measures at Construction Sites

- The following preventative measures shall be implemented for all construction sites:



<p>Movement of Construction Vehicles, Vessels and Equipment</p>	<ul style="list-style-type: none"> <li>• All construction vehicles, vessels (i.e., boats, barges, etc.) and equipment will be cleaned off-site before coming onto the project site and before leaving an area of infestation.</li> <li>• Boats shall be free of ballast water.</li> </ul>
<p>Cleaning of Construction Vehicles, Vessels and Equipment</p>	<ul style="list-style-type: none"> <li>• Vehicles, vessels and equipment should be cleaned at least weekly and in accordance with the Ontario Invasive Plant Council’s “Clean Equipment Protocol” for cleaning of vehicles and equipment. See Vehicle and Equipment Washing and Cleaning (<a href="#">ESG-16-C</a>) for additional guidance.</li> <li>• Pressure wash (non-frozen conditions) or use compressed air (frozen conditions) to clean vehicles, vessels and equipment when leaving infested areas.</li> </ul>
<p>Construction Crews</p>	<ul style="list-style-type: none"> <li>• Work attire, boots, and other personal protection equipment will be cleaned in accordance with the Ontario Invasive Plant Council’s “Clean Equipment Protocol”.</li> </ul>
<p>Construction Materials</p>	<ul style="list-style-type: none"> <li>• Contractors shall certify that all construction material sources used for supplies of sand, gravel, rock and mulch are weed-free prior to obtaining or transporting any material from them. Obtain and use only certified weed-free straw or use fiber roll logs for sediment containment. Hay shall not be used as it contains seed heads and seeds from agricultural fields (often weedy/invasive species).</li> </ul>
<p>Construction Works and Activities</p>	<ul style="list-style-type: none"> <li>• Soils where invasive species are present will not be reused or left on-site but disposed off-site at a licensed facility.</li> <li>• No intact, untreated wood will be removed off-site or brought to the site, to prevent the spread of invasive insects, unless removed by a Qualified Professional(s) following approved treatment or disposal methods.</li> <li>• Invasive fish species shall not be relocated during fish salvage operations. If invasive species are caught, fish will be euthanized and disposed of according to Canadian Council on Animal Care’s “Guidelines on The Care and Use of Fish in Research, Teaching and Testing”.</li> </ul>
<p>Inspections</p>	<ul style="list-style-type: none"> <li>• Vehicle, vessel and equipment inspection shall be done before: <ul style="list-style-type: none"> <li>○ Moving vehicles out of a local area of operation.</li> <li>○ Moving machinery between properties or sites within the same property where invasive species may be present in one area, and not in another.</li> <li>○ Using machinery along roadsides, in ditches, and along watercourses.</li> <li>○ Vehicles using unformed dirt roads, trails or off road conditions.</li> <li>○ Using machinery to transport soil and quarry materials.</li> <li>○ Visiting remote areas where access by vehicles is limited.</li> </ul> </li> </ul>



Post-Construction Works and Activities	<ul style="list-style-type: none"><li>• Revegetate or otherwise prevent the establishment of invasive species in all areas of the job site through a program of monitoring and post-construction weed treatment for the life of the project.</li><li>• Revegetate using soil components and mulches obtained from non-weed infested sources.</li><li>• Utilize seed and other plant material that has been checked and certified as noxious weed-free and that has a weed content of 0.05% or less.</li><li>• Revegetate using native plant materials that have a high likelihood of survival.</li><li>• Maintain all planted material and native vegetation located on the project site for the life of the project.</li><li>• Monitor all seeded sites for weed infestation. Treat all weeds adjacent to newly seeded areas prior to planting and treat planted areas for weeds in the first growing season.</li></ul>
--	--

#### Control Measures in Areas Infested with Invasive Species

- Control measures shall be undertaken for infestations of invasive plant species prior to and after construction under the supervision of a Qualified Professional(s). The control method should be informed by the biological characteristics of the species, the size of the infestation, and the potential to transport on-site and off-site. Acceptable methods of invasive species control include:
  - **Mechanical Control** – Mechanical control methods involve doing manual labour to remove the vegetation from the ground. Some techniques include cutting, pulling, mowing, smothering, removing the outer layer from the stem, or prescribed burning.
  - **Chemical Control** – Chemical control methods involve using herbicides to target the invasive plant species. Pesticides should only be used if other more desirable methods did not work and if there is a net benefit to the environment that is positive. Any proposed chemical control must be included in the site-specific EMP and accepted by PCA.

#### *Related Environmental Standards and Guidelines*

- General Environmental Protection Procedures
- Vegetation Clearing and Protection (ESG-5-Pre)
- Fish Exclusion, Salvage and Relocation (ESG-7-C)
- Revegetation (ESG-1-Post)

#### *Related EMP Component Plans*

- Transportation Management
- Wildlife Protection and Management
- Aquatic Resources Management
- Species at Risk Protection
- Invasive Species Management



### *Further Guidance*

Canadian Council on Animal Care, 2005. Guidelines on The Care and Use of Fish in Research, Teaching and Testing. ISBN: 0-919087-43-4. Available at: <http://www.ccac.ca>.

Ontario Invasive Plant Council, 2013. Clean Equipment Protocol for Industry - Inspecting and cleaning equipment for the purposes of invasive species prevention. Available at: [http://www.ontarioinvasiveplants.ca/wp-content/uploads/2016/07/Clean-Equipment-Protocol\\_June2016\\_D3\\_WEB-1.pdf](http://www.ontarioinvasiveplants.ca/wp-content/uploads/2016/07/Clean-Equipment-Protocol_June2016_D3_WEB-1.pdf)

### *References*

Ontario Ministry of Agriculture, Food and Rural Affairs, 2015. Noxious Weeds in Ontario. Available at: [http://www.omafra.gov.on.ca/english/crops/facts/noxious\\_weeds.htm](http://www.omafra.gov.on.ca/english/crops/facts/noxious_weeds.htm)

Ontario Invasive Species Strategic Plan 2012. Government of Ontario. Available at: [http://www.mnr.gov.on.ca/stdprodconsume/groups/lr/@mnr/@biodiversity/documents/document/stdprod\\_097634.pdf](http://www.mnr.gov.on.ca/stdprodconsume/groups/lr/@mnr/@biodiversity/documents/document/stdprod_097634.pdf)

Invasive Species Management for Infrastructure Managers and the Construction Industry 2008.

Wade, M. Booy, O. and White, V. Available at:

[http://www.ciria.org/service/Web\\_Site/AM/ContentManagerNet/ContentDisplay.aspx?Section=Web\\_Site&ContentID=9001](http://www.ciria.org/service/Web_Site/AM/ContentManagerNet/ContentDisplay.aspx?Section=Web_Site&ContentID=9001)



# Pile Driving (ESG-12-C)

---

## Application to Ontario Waterways' Projects

Pile driving is often used to establish or support the foundations of buildings and structures, control settlement or used as part of a coffer dam installation (e.g., sheet pile coffer dam). Pile driving has the potential to result in adverse noise and vibration to local receptors including nearby residents and communities as well as wildlife. When conducted in water or in proximity to a waterway, pile driving also has the potential to disturb or harm fish and adversely affect water quality.

## Description of Activity

Pile driving can be undertaken using a variety of construction methods, equipment and materials. Hammers; including drop, diesel, air, vibratory and hydraulic, vibroflot, and rotary, air and churn drills are the primary instruments in a pile driving operation. These hammers and drills are supported by a wide variety of heavy equipment, including a range of conventional cranes (truck mounted, crawler and pedestal mounted), scows and barges. The piling types may include: lumber, concrete and steel piles (pipes, beams and sheets).

## Environmental Standards and Guidelines

- All pile driving activities shall be undertaken under the supervision of a Qualified Professional.
- The PCA Environmental Authority shall be contacted and advised at least 48 hours in advance of the start-up of the proposed pile driving operations.
- Use inert (concrete, steel) or untreated materials that are to be submerged in water. Treated lumber must not be used as it may contain compounds that can be released into the water and become toxic to the aquatic environment. Any proposed use of treated wood must be approved by PCA and undertaken in accordance with PCA's "Guidelines for the Use, Handling and Disposal of Treated Wood" (Parks Canada, 2009).
- Timing windows for in-water works shall be respected for pile driving activities in water.
- The energy required to drive the pile to the final point of installation shall not result in sound pressure in excess of 30 kPa (BC Marine and Pile Driving Contractors Association and Fisheries and Oceans Canada, 2003).
- Visual and hydrophone monitoring of the impact on fish by the sound waves emitted will be required when driving concrete piles with a diameter greater than 60 cm (approximately 24 inches) (BC Marine and Pile Driving Contractors Association and Fisheries and Oceans Canada, 2003).
- Pile driving should be done within an isolated work area where fish have been excluded, salvaged and relocated.
- Pile driving shall be conducted from the shore or from an existing structure (e.g., berm, dam) where possible.
- If necessary, pile driving in water shall be conducted from a floating structure (i.e., a barge) so that disturbance to the waterbody bottom is prevented. In addition:
  - sufficient water must be present to prevent the barge from grounding;
  - minimize the use of barge stabilizing spuds and their disturbance of bottom substrates;
  - fully restore any areas disturbed by barge stabilizing spuds;
  - prop scour must not occur from tending vessel(s). This may require maneuvering of barges in shallow water with ropes tied to shore and/or pilings;



- exclude fish and other wildlife from the work area prior to the commencement of any pile driving operations;
- All boats and equipment used in pile driving operations will be cleaned off-site before coming onto the project site and before leaving the project site; and
- Boats shall be free of ballast water.
- If conducting pile driving work during the winter, inspect shoreline conditions and foreshore substrates to determine whether frozen conditions exist and if machine pads are required to minimize disturbance.

#### *Related Environmental Standards and Guidelines*

- General Environmental Protection Procedures
- Fish Exclusion, Salvage and Relocation ([ESG-7-C](#))
- Invasive Species Management ([ESG-11-C](#))
- Refueling and Spill Management ([ESG-13-C](#))
- Treatment of Discharge Waters ([ESG-14-C](#))
- Use and Maintenance of Heavy Equipment ([ESG-15-C](#))
- Vehicle and Equipment Washing and Cleaning ([ESG-16-C](#))
- Wildlife and Species at Risk Protection During Construction ([ESG-17-C](#))

#### *Related EMP Component Plans*

- Dust and Air Quality Management
- Noise, Vibration and Ambient Light Management
- Blasting
- Site Dewatering and Wastewater Plan
- Surface water Management, Erosion and Sediment Control
- Dredging and Sediment Removal
- Fuel Management
- Spills Prevention and Emergency Response
- Dam and/or Bypass Channel Commissioning

#### *Further Guidance*

Parks Canada, 2009. Guidelines for the Use, Handling and Disposal of Treated Wood.

BC Marine and Pile Driving Contractors Association and Fisheries and Oceans Canada, 2003.

Best Management Practices for Pile Driving and Related Operations. March 2003. Available at: <https://projects.eao.gov.bc.ca/api/document/5887e34fad20ac134d916367/fetch>

#### *References*

British Columbia Ministry of Environment, General BMPs and Standard Project Considerations - Standards and Best Practices for Instream Works. Available at: <http://www.env.gov.bc.ca/wld/instreamworks/downloads/GeneralBMPs.pdf>





# Refueling and Spill Management (ESG-13-C)

---

## Application to Ontario Waterways' Projects

The use of heavy equipment and other machinery near water is generally required on many PCA construction and maintenance projects on Ontario Waterways. Refueling and routine maintenance of this machinery occur at the work site on a daily basis. Although most machinery is mobile, some equipment such as pumps and cranes cannot practically be relocated for fueling and maintenance. Fuel, grease and other mechanical fluids are pollutants and considered a deleterious substance under the *Fisheries Act*. The proximity of PCA's assets to natural areas and fish bearing waterbodies elevates the need to address refueling and routine maintenance through the application of these standards and guidelines. Most Ontario Waterways sites do not have space to allow for refueling in areas greater than 30 m from the water.

## Description of Activity

Refueling and maintenance refer to the regular activity of providing fuel, upkeep and light duty repair to heavy equipment and other construction machinery throughout the construction period. The most common form of potential fuel contamination on work sites occurs from drips and spills released from fueling nozzles and gas can spouts as they are moved between the fuel tank and the equipment. Being a daily activity, the potential for drips and minor spills is a common and frequently occurring potential environmental hazard.

## Environmental Standards and Guidelines

### General

- A Fuel Management plan, including refueling procedures, shall be developed as part of the site-specific EMP and accepted by PCA.
- A Spill and Emergency Management Plan will be developed as part of the site-specific EMP and accepted by PCA. The Spill and Emergency Management plan shall use a risk based approach. It shall be tailored to seasonal conditions at the site.

### Fuel Storage

- Fuel storage facilities and containers shall comply with the CCME Environmental Code of Practice for Aboveground and Underground Storage Tank Systems Containing Petroleum and Allied Petroleum Products. Double-walled storage containers must be used and located within a berm or impermeable containment boom.
- All fuel storage and containment must be intact, monitored and replaced as required through all phases of the project.

### Refueling

- Vehicle, heavy equipment and machinery re-fuelling shall be conducted in a designated, flat and low sensitive area. Commonly, this area is the same location that fuel and other chemicals are stored.
- Designated refueling areas shall be constructed with impermeable containment such as berms, booms and liners. They shall contain an adequately sized drip tray or other impermeable layer to capture and contain drips from the nozzle and minor spills. Snow and water must be managed



from the drip trays to prevent contamination of the water. Drip trays must be on level ground. Any contaminated soil or aggregate must be disposed of properly.

- Spill containment for refueling shall be sized adequately to accommodate the volume of the fuel source container.
- The use of small volume fuel cubes is preferred for refueling immobile equipment and equipment operating in or near water.
- Fuel trucks and hoses cannot be used on coffer dam or within dewatered areas.

### Spill Management and Reporting

- All construction staff should be trained and familiar with the Spills and Emergency Management plan, including roles and responsibilities, locations and contents of spill kits, and use of equipment. A check list approach should be developed for staff to sign-off and confirm training.
- Upon identification of a spill, immediate containment is required. All areas affected by the spill shall be remediated.
- Spill response equipment shall be located and maintained on-site and utilized in accordance with applicable the spill containment procedures. Multiple spills kits (number to match the scale of the project and to isolate a contaminated area) shall be placed in covered, accessible structures around the construction site.
  - Typical spill response equipment (spill kit) shall include as a minimum: absorbent spill pads, berms, cover drains and personal protective equipment (materials for both in-water and on land spill) to be used to contain the spill as appropriate. Replace or repair material after use.
  - Concrete spill response equipment (spill kit) will include as a minimum: sand bags (number to match the scale of the project and to isolate a contaminated area); impermeable material to line sandbags; Impermeable turbidity curtains; and CO<sub>2</sub> Bubblers. Replace or repair material after use.
- Wastes that are generated from remedial operations that are considered to be hazardous wastes under Ontario Regulation 347 of the *Environmental Protection Act* must be contained in sealed containers and temporarily stored on the project site until they are collected for disposal by a licensed waste hauler.
- All other non-hazardous waste generated by a concrete pour operation shall be disposed according to Ontario Regulation 558/00. R.R.O. 1990 (General – Waste Management).
- Environmental permits shall be obtained by the Contractor for any off-site disposal
- Any spill into water, onto ice or in a dewatered area must be reported immediately to PCA's Environmental Authority, the Departmental Representative and the Ontario Ministry of Environment and Climate Change's Spills Action Centre (SAC).
- Any spill on land must be reported immediately to PCA's Environmental Authority and the Departmental Representative. Any spill on land meeting the criteria set out in Ontario's *Environmental Protection Act*, O. Reg. 675/98 must be reported immediately to the Ontario Ministry of Environment and Climate Change's Spills Action Centre (SAC).

### Related Environmental Standards and Guidelines

- General Environmental Protection Procedures
- Use and Maintenance of Heavy Equipment (ESG-15-C)



### *Related EMP Component Plans*

- Dust and Air Quality Management
- Noise, Vibration and Ambient Light Management
- Transportation Management
- Site Dewatering and Wastewater Plan
- Surface Water Management, Erosion and Sediment Control
- Dredging and Sediment Removal
- Vegetation Protection
- Aquatic Resources Management
- Species at Risk Protection
- Hazardous Materials Management
- Fuel Management
- Spills Prevention and Emergency Response

### *Other Design and Environmental Considerations*

- Spill prevention and response measures shall consider spills on land, in water and on ice.

### *References*

Environment Yukon, 2011. Best Management Practices for Works Affecting Water in Yukon. Water Resources Branch, Government of Yukon.

VOI Training Group, 2014. Environmental Field Procedures for Works in and About Water. Developed by Van Osch Innovations Ltd., 130 Columbia Street, Nanaimo, British Columbia, Canada.



# Treatment of Discharge Waters (ESG-14-C)

---

## Application to Ontario Waterways' Projects

In-water works often require isolation of work areas to perform construction and maintenance activities in the “dry”. This will require pumping of water from the isolated worksite (e.g., from behind a coffer dam, aqua-dams, or other temporary dams constructed with rock, pea gravel bags, concrete blocks, steel or wood walls) or from inside a lock and discharging the water into a receiving watercourse or elsewhere. Most construction sites on Ontario Waterways will have limited area that can be used for sediment retention pond construction, which limits pond size and consequently decreases settling efficiency. Therefore, novel methods will need to be considered to ensure that the water discharged meets specified performance criteria in the receiving waters. Design coffer dams to have a clean water collection area that can be directly discharged back to the river – this will limit the need to remove turbid water from the worksite.

High velocity flows from discharge structures (e.g., pipes) or outfalls can cause extensive erosion and scour at an outfall and/or receiving waterway. Every attempt should be made to decrease this energy where erosion concerns warrant. If discharged directly to a watercourse there may be no requirement.

## Description of Activity

Treatment of discharge waters is intended to control sediment concentrations in water pumped from a work area and discharged downstream. Treatment options include:

- Isolate clean water from the worksite to minimize the amount of turbid water requiring treatment
- Sediment retention and waste water storage ponds;
- Water tanks and tanker trucks;
- Dedicated wastewater and filtration equipment;
- Sediment retention “bags”.
- The use of a flocculation treatment

Suitable techniques for energy dissipation must be tailored to the amount of flow expected compared to the erodibility of the soil at the outflow location. These techniques are also used to slow the flow out of lined open channels such as spillways, ditches and other hydraulic structures.

## Environmental Standards and Guidelines

- The pumping of turbid water directly back into the waterbody is not permitted. Water which is in exceedance of the following performance criteria must be treated/managed appropriately:
  - At the discharge points of pumping into any waterbody, a maximum increase of suspended sediment concentration shall not be more than 25 mg/L over background levels during any short term exposure period (i.e., less than 24 hours). For longer term operations (i.e., more than 30 days), average suspended sediment concentrations shall not be increased by more than 5 mg/L over background levels. Note: the field measurement for turbidity will be in NTU. TSS (mg/L) is only acceptable from lab results and will only be used if there is exceedances and potential enforcement action.
  - At the discharge points of pumping into any waterbody, a maximum increase of 8 NTU from background levels for a short-term exposure (i.e., 24 hours). Maximum average increase of 2 NTU from background levels for a longer term exposure (e.g., more than 30 days). Should



- there be exceedances then PCA/Contractor may analyze Suspended Solids (SS) concentration with lab samples. Measurements should be taken  $\mu$ s(background) within the work area and downstream directly in the receiving water.
- Receiving waters at the point of discharge shall be routinely tested and compared to background to confirm compliance with performance standards (e.g., pH readings should be taken if there is any concrete work being completed).

#### Sediment Retention and Waste Water Storage Ponds

- Avoid steep and or unstable slopes, surface water and wetlands, areas with soils susceptible to erosion and existing drainage channels (VOI).
- Ponds are to be used when the anticipated volume of water is very large. A site specific design (e.g., location, size, configuration) for the sediment pond shall be prepared by a Qualified Professional in accordance with standards provided in Sediment Control (ESG-2-Pre).
- A Qualified Professional(s) should design embankment dykes and other water retaining structures to avoid failure.
- The optimal design parameters is a 5:1 to 10:1 length to width ratio is preferred (VOI Training Group, 2014).
- Areas to be used for a pond shall be identified in the site-specific EMP and accepted by PCA.
- Ponds shall be constructed prior to any construction activity with the exception of vegetation clearing and grubbing for the pond itself.
- Ponds are largely dependent on the sediment type as a result there needs to be sufficient retention time for the various sediment types to settle.
- Embankment dykes should be stripped of vegetation, and fill materials should be clean soil, properly compacted.
- The main outlet structure should be installed at the farthest possible point from the inlet to encourage settling. An emergency spillway should be constructed to convey flows not carried by the main outlet to prevent embankment failure during high volume and flow periods.
- Prevent erosion of outlets by reinforcing/armoring them with rip rap or other appropriate measures If utilizing reinforcement/armoring measures consider the following:
  - place large, durable, clean (free of fine particulate matter), suitably graded and sized angular rocks (rip rap) into the eroding area at the outlets only;
  - carefully unload and key into place (if placing rocks along the embankment) above the high water mark (HWM);
  - implement appropriate erosion and sediment control measures and maintain their functionality;
  - do not obtain rocks from below the high water mark (HWM) of any water body;
  - install rip rap at a similar slope as the stream bank to maintain a uniform stream bank slope and natural stream alignment;
  - use acid-free rocks; and
  - ensure rip rap does not constrict the channel width or flow.
- Sediment retention ponds should be inspected regularly and during high volume and flow periods.
- Sediment accumulation in the ponds must be measured regularly as required. Bathymetric surveys indicate the amount of sediment that has accumulated within the pond and consequently, estimates the remaining stormwater pond life, and dredging volumes. The pond will require cleaning when sediment accumulation reaches 50% of the design capacity.
- Waste water storage ponds are used to store waste waters with no provision to discharge the water into a well vegetated area or a receiving watercourse.



### Water Tanks and Trucks

- Water tanks and trucks can be used to temporarily store small volumes of water prior to discharge, typically at an off-site location.
- An incremental or iterative approach should be used, whereby additional capacity is added
- Any off-site or on-site discharge location shall be identified and approved in the EMP. Environmental permits shall be obtained by the Contractor for any off-site discharges.
- If transport and disposal is interrupted, in-water works that require pumping should be stopped.
- If clean, Water stored in tanks and trucks can be used for fugitive dust control

### Sediment Retention Bags

- Sediment retention bags are best used when appropriately sized sediment retention or waste water ponds cannot be located on-site. See Sediment Control (ESG-2-Pre) for further guidance.
- For fine sediment soils treating discharge water prior to the filter bag with a flocculant will improve results.
- Bags are manufactured in various sizes with various opening sizes. The numbers, type and size of filter bag should be determined by a Qualified Professional(s) based on expected discharge rates and predicted particle sizes to be treated.
- Not to be used for concrete waste water as it will not filter pH.
- High quality woven monofilament geotextile of 100% polypropylene stable fibers are preferred to non-woven geotextile materials.
- Areas to be used for sediment retention bags shall be identified in the site-specific EMP and accepted by PCA. A minimum setback of 10 m from a watercourse is recommended.
- The sediment retention bag must be secured to the ground surface, surrounded by silt fencing and straw bales with a designed outlet.
- If a flocculant is used it must be designed for the soil type and for optimum mixing and retention time prior to release at the outlet. Use a treated Jute with flocculant to clarify the discharge water.
- Any off-site disposal location shall be identified in the site-specific EMP and accepted by PCA. Environmental permits shall be obtained by the Contractor for any off-site disposal of bags and sediment.

### Dedicated Wastewater and Filtration Equipment

- Must be designed by engineer for expected flows and soil types
- Dedicated filtration equipment should be used when appropriately sized sediment retention or waste water ponds or sediment retention bags cannot be located on-site. Suitable options include:
  - Sediment treatment tank with internal weirs (over and under weirs), to remove waste, solids (gravel, sand, and silt), visible oil grease and hydrocarbons, and some metals (removed with sediment);
  - Sand Media Filters, Clay & Carbon Media Filters; and
  - Canister Filters.
- Flocculent addition can be done to waters contained Enviro-Tanks and canister filters so that mixing can be done in a controlled mode.
- Any off-site disposal location shall be identified and approved in the EMP. Environmental permits shall be obtained by the Contractor for any off-site disposal of sediment.



### Energy Dissipation

- All water discharge structures or outfalls will be designed with energy dissipation devices where erosion is likely to occur.
- The design of an energy dissipation device is unique to the site. The Qualified Professional designing the system should consider that the device may not match these specifications. However, as long as it can be proven to both dissipate energy and protect against erosion and scour, it can be considered acceptable.
- The energy dissipater (width, length substrate) will be designed according to the expected outflow velocities and soil types and will be detailed in the dewatering plan.
- Outfalls shall not be located in areas of steep slopes or banks or where the bank is susceptible to slumping.
- Any erosion protection applied must be free of fines (overburden, spoil, silt, clay, and or organic material).
- Energy dissipation devices will be inspected before periods of flow to ensure they are functioning as expected. The devices should also be inspected periodically to check for scour and if there are any repairs required. Typical maintenance practices include:
  - Restore dissipater to its original specifications if it is found to diverge from design criteria.
  - Replace rock or other components that have been dislodged by heavy flows.
  - If rock continues to wash away, consider using larger material.
  - Repair and damage to underlying fabric.
  - Where erosion/scour is occurring outside dissipater area, increase dissipater size in the eroded area.
  - Frequently remove sediment and other debris accumulations from inlets, flow pipes/ditches, and the dissipater area.

### *Related Environmental Standards and Guidelines*

- General Environmental Protection Procedures
- Erosion Control (ESG-1-Pre)
- Sediment Control (ESG-2-Pre)

### *Related EMP Component Plans*

- Blasting
- Demolition
- Site Dewatering and Wastewater Plan
- Surface Water Management, Erosion and Sediment Control
- Dredging and Sediment Removal
- Vegetation Protection
- Aquatic Resources Management
- Invasive Species Management
- Waste Management
- Spill Prevention and Emergency Response



### *Other Design and Environmental Considerations*

- Sediment retention bags have seasonal limitations as they can freeze in the winter, reducing capacity and effectiveness.
- Large retention ponds may be required to retain fine sediments, while smaller ponds may only be effective to retain larger sediment sizes (e.g., sands).
- If suspended sediment concentrations are very high in the discharge water and/or receiving watercourse, discharges could be shut down until issues are identified and rectified.
- The design of an energy dissipation device is unique to the site. The engineer designing the system should consider that the device may not match these specifications. However, as long as it can be proven to both dissipate energy and protect against erosion and scour, it can be considered acceptable.
- For appropriate design for drainage system outfalls, OMAFRA Factsheet, Subsurface Drainage System Outfalls.

### *Further Guidance*

Ontario Ministry of Agriculture, Food and Rural Affairs, 2015. Subsurface Drainage System Outfalls Factsheet. October 2015. Available at: <http://www.omafra.gov.on.ca/english/engineer/facts/13-035.htm>

Ontario Ministry of Environment and Energy (MOEE), 2003. Stormwater Management Planning and Design Manual, March, 2003.

### *References*

Department of Fisheries and Oceans (DFO), 1995. Freshwater Intake End-of-Pipe Fish Screen Guideline. ISBN 0-662-23168-6. Catalogue No. Fs 23-270 / 1995E.

Nova Scotia Ministry of Environment, 2015. Nova Scotia Watercourse Alterations Standard.

Ontario Ministry of Transportation, 2011. OPSS511 – Construction Specification for Rip-Rap, Rock Protection and Granular Sheeting. April 2001.

Oregon Department of Transportation. Hydraulics Manual. Chapter 11 – Energy Dissipaters. Available at: [https://www.oregon.gov/ODOT/HWY/GEOENVIRONMENTAL/docs/Hydraulics/Hydraulics%20Manual/CHAPTER\\_11.pdf](https://www.oregon.gov/ODOT/HWY/GEOENVIRONMENTAL/docs/Hydraulics/Hydraulics%20Manual/CHAPTER_11.pdf)

VOI Training Group, 2014. Environmental Field Procedures for Works in and About Water. Developed by Van Osch Innovations Ltd., 130 Columbia Street, Nanaimo, British Columbia, Canada.





# Use and Maintenance of Heavy Equipment (ESG-15-C)

---

## Application to Ontario Waterways' Projects

The use of heavy equipment near water is generally required on many PCA construction and maintenance projects on Ontario Waterways. Heavy equipment moving through the construction area has the potential to render soils susceptible to erosion. Used in proximity to waterbodies, heavy equipment can destabilize banks and affect water quality through the release of fuel, grease and other fluids. In-water use of heavy machinery can also affect fish habitat through the resuspension of fine sediments and creation of elevated turbidity. The proximity of PCA's assets to fish bearing waterbodies elevates the need to address these potential impacts and adhere to best practices and guidelines for the protection of fish and water quality during near water and in water construction projects on Ontario Waterways.

## Description of Activity

Heavy equipment includes all specialized construction tracked or tired vehicles or machinery used during PCA maintenance, upgrade or construction projects. Such equipment is often used to transport or lift into place construction materials or move, excavate or compact soil.

## Environmental Standards and Guidelines

- All heavy equipment to be used on-site, their anticipated designated work areas and site entrances shall be described in the site-specific EMP and accepted by PCA.
- An equipment maintenance program shall be described in the site-specific EMP and accepted by PCA.

## Heavy Equipment Condition

- All heavy machinery brought to the work site shall be in good repair, free of leaks and be externally cleaned / degreased. All equipment using hydraulic fluids shall use vegetative (non-petroleum based) based fluids.
- All heavy equipment should comply with the latest equipment specifications in the *Off-Road Compression-Ignition Engine Emission Regulations (SOR/2005-32)* that contain emission standards for diesel engines used in off-road applications such as those typically found in construction. The Regulations, under Section 160 of the *Canadian Environmental Protection Act, 1999 (CEPA 1999)*, are applied to engines of the 2006 and later model year.
- All heavy machinery brought to the work site shall arrive free of soil, seeds and vegetation fragments to avoid the import and spread of invasive species.
- Equipment shall be inspected prior to arrival on site. An inspection checklist shall be included in the site-specific EMP and accepted by PCA.



### Stabilized Site Entrances and Heavy Traffic Areas

- All site entrances shall be stabilized as per standards set in Sediment Control (ESG-2-Pre).
- Equipment storage areas, laydown areas and other high traffic areas shall be stabilized with geotextile overlain with a minimum 15 cm of clean gravel surface layer or other suitable cover material.

### Heavy Equipment Use

- Heavy equipment shall be operated exclusively by trained equipment operators or other Qualified Professionals.
- Heavy machinery shall operate from above the top of the streambank, on-shore above the normal water level, or within a dewatered site. Heaving equipment shall not enter water. Only working part of equipment (bucket or drill end or equivalent) entering the water shall be free of fluid leaks and externally cleaned/degreased to mitigate any deleterious substance from entering the water.
- Heavy machinery shall not be parked overnight or for long periods of shutdown in dewatered areas or on coffer dams. Where site conditions do not allow for removal of equipment, other measures to address potential flooding must be implemented (e.g., ground protection mats or rig mats)
- For guidance on refueling, see Refueling and Spill Management (ESG-13-C).

### Related Environmental Standards and Guidelines

- General Environmental Protection Procedures
- Erosion Control (ESG-1-Pre)
- Sediment Control (ESG-2-Pre)
- Vegetation Clearing and Protection (ESG-5-Pre)
- Installation and Removal of Cofferdams and Isolation Structures (ESG-10-C)
- Refueling and Spill Management (ESG-13-C)
- Vehicle and Equipment Washing and Cleaning (ESG-16-C)

### Related EMP Component Plans

- Dust and Air Quality Management
- Noise, Vibration and Ambient Light Management
- Transportation Management
- Blasting
- Demolition
- Site Dewatering and Wastewater Management
- Surface Water Management, Erosion and Sediment Control
- Dredging and Sediment Removal
- Vegetation Protection
- Wildlife Protection and Management
- Aquatic Resources Management
- Invasive Species Management
- Fuel Management
- Spills Prevention and Emergency Response



### *Other Design and Environmental Considerations*

- The Regulations Amending the Off-Road Compression-Ignition Engine Emission Regulations (the Amendments) impose stricter standards and new requirements starting with engines of the 2012 and later model years.

### *References*

CISEC, 2014. Certified Inspector and Sediment and Erosion Control Training Manual. Revised Edition V6. 9520 Pine valley Drive, Woodbridge Ontario, Canada.

Coker, G.A., Ming, D.L., and Mandrak, N.E. 2010. Mitigation Guide For The Protection Of Fishes and Fish Habitat To Accompany The Species at Risk Recovery Potential Assessments Conducted by Fisheries and Oceans Canada (DFO) in Central and Arctic Region. Version 1.0. Can. Manuscript Rep. Fish. Aquatic. Sci. 2904: vi + 40 p.

Erosion and Sediment Control Guidelines for Urban Construction, 2006. Greater Golden Horseshoe Area Conservation Authorities.

VOI Training Group, 2014. Environmental Field Procedures for Works in and About Water. Developed by Van Osch Innovations Ltd., 130 Columbia Street, Nanaimo, British Columbia, Canada.



# Vehicle and Equipment Washing and Cleaning (ESG-16-C)

---

## Application to Ontario Waterways' Projects

Construction activity requires numerous types of vehicles, boats and equipment, such as: passenger cars and trucks, all terrain vehicles (ATV's), snowmobiles, boats and heavy equipment (e.g., trucks, tractors, backhoes, graders, dozers, excavators, skidders, loaders, cement pumpers, water tankers and trucks). Construction vehicles, boats and equipment will become soiled over time and require washing and cleaning, particularly if they are to be used or transported off the construction site. Washing and cleaning reduces fugitive dust emissions and is integral to invasive (non-native) species management.

## Description of Activity

Washing and cleaning is a process of inspection, sweeping, vacuuming or using a compressed air or a high pressure hose to wash and clean vehicles, boats and equipment from visible direct and plant material. This ESG does not address solvent cleaning, abrasive cleaning, and other types of cleaning such as ultrasonic cleaning, chemical polishing and electro-polishing.

## Environmental Standards and Guidelines

- Inspection, washing and cleaning of all vehicles, boats and equipment should be performed in accordance with the procedures, checklists and diagrams provided in the "Clean Equipment Protocol for Industry - Inspecting and Cleaning Equipment for the Purposes of Invasive Species Prevention", as summarized below:
  - When vehicle/equipment washing/cleaning must occur on-site, and the operation cannot be located within a structure or building equipped with appropriate water management facilities, the outside cleaning area should be:
    - accepted by PCA prior to use;
    - mud free, gravel covered or a hard surface (i.e., stabilized construction entrance if designated to handle runoff). If this option is not available, choose a well maintained (i.e., regularly mowed) grassy area;
    - gently sloping to assist in draining water and material away from the vehicle or equipment;
    - at least 30 m away from any watercourse, water body and natural vegetation; and
    - large enough to allow for adequate movement of larger vehicles and equipment.
  - Washing and cleaning is required when inspection identifies visible dirt, plant material or snow and when moving vehicles, boats or equipment from one area to another or off-site.
  - Used of compressed air is preferred to pressure washing. Compressed air may also be used under frozen conditions.
  - Clean the interior of the vehicle by sweeping, vacuuming or using a compressed air device. Particular attention should be paid to the floor, foot wells, pedals, seats, and under the seats.
  - Clean the interior of the vehicle by sweeping, vacuuming or using a compressed air device. Particular attention should be paid to the floor, foot wells, pedals, seats, and under the seats.



- Clean exteriors of vehicles, boats and equipment with either compressed air or a high pressure hose in combination with a stiff brush and/or pry bar to further assist the removal of dirt.
- Equipment such as boats that may be exposed to aquatic invasive species should also be disinfected with bleach solution before conducting work in a new area or left to dry for 5-7 days in warm, dry weather.
- The use of diesel for vehicle and equipment cleaning is prohibited. Cleaning of vehicles and equipment with soap, solvents or steam should not occur on the project site.
- Resulting wastewater must be fully contained and treated in accordance with Treatment of Discharge Waters ([ESG-14-C](#)) and Sediment Controls ([ESG-2-Pre](#)).
- If the area has been identified as having invasive species, waste water will be disposed of off-site.

#### *Related Environmental Standards and Guidelines*

- General Environmental Protection Procedures
- Sediment Control ([ESG-2-Pre](#))
- Vegetation Clearing and Protection ([ESG-5-Pre](#))
- Invasive Species Management ([ESG-11-C](#))
- Revegetation ([ESG-1-Post](#))

#### *Related EMP Component Plans*

- Dust and Air Quality
- Transportation Management
- Surface Water Management, Erosion and Sediment Control
- Vegetation Protection
- Aquatic Resources Management
- Invasive Species Management
- Fuel Management

#### *Further Guidance*

Ontario Invasive Plant Council, 2013. Clean Equipment Protocol for Industry - Inspecting and cleaning equipment for the purposes of invasive species prevention. Available at: [http://www.ontarioinvasiveplants.ca/wp-content/uploads/2016/07/Clean-Equipment-Protocol\\_June2016\\_D3\\_WEB-1.pdf](http://www.ontarioinvasiveplants.ca/wp-content/uploads/2016/07/Clean-Equipment-Protocol_June2016_D3_WEB-1.pdf)



# Wildlife and Species Protection During Construction (ESG-17-C)

---

## Application to Ontario Waterways' Projects

Construction projects on Ontario Waterways are undertaken on lands that are often well vegetated with natural vegetation (e.g., forests, wetlands, grasslands, etc.) or grounds that have been landscaped. Similarly, projects on Ontario Waterways are undertaken in or near water. These areas and watercourses can provide suitable habitat for a variety of wildlife species including Species at Risk (SAR).

All projects on Ontario Waterways must be in compliance with the *Species at Risk Act (SARA)* and have regard for listed species identified by the Province in the *Ontario Endangered Species Act* that are not listed under the federal *SARA*.

Ontario Waterways evaluates the impact on species listed under the *SARA* whenever it grants a formal permit, or undertakes work that has the potential to affect species or habitats. Ontario Waterways may require follow-up and monitoring to be undertaken that is consistent with relevant species' recovery strategies and action plans, and the objectives, scope, timelines and responsibilities for monitoring activities outlined in the EIA report.

## Description of Activity

Wildlife protection during construction involves the diligent implementation of wildlife and related habitat mitigation measures identified in the EIA along with relevant best practices, specifications and performance criteria, particularly timing windows. In addition, wildlife protection during construction will require recording and reporting of incidental encounters with wildlife (non-SAR).

SAR protection involves the diligent implementation of SAR mitigation measures identified in the EIA along with relevant best practices, specifications and performance criteria, particularly timing windows. In addition, SAR protection will require contractor staff training and awareness that support the implementation of procedures and work modifications to be undertaken in the event of encounters with SAR. Prompt recording and reporting of SAR encounters is also required.

## Environmental Standards and Guidelines

### General

- All wildlife and habitat related mitigation measures identified in the EIA and any other measures proposed must be included in the site-specific EMP and accepted by PCA. All measures must be implemented, with special emphasis on:
  - the construction timing windows identified in the Project's EIA;
  - tailoring protection measures to wildlife seasonal patterns; and
  - the implementation of any protection measures aimed at excluding wildlife species from the work area, minimizing disturbance/harm and any "no go" areas aimed at excluding project works activities from species habitats.
- The work site should be inspected by a Qualified Professional(s) prior to vegetation clearing, to identify potential wildlife issues (e.g., hibernating animals or nursing mothers and their young, etc.) and to inform or adjust mitigation planning as needed. The timing and scope of this



inspection will vary depending on the type and extent of habitat to be affected and the anticipated timing for site clearing. If recommended by a Qualified Professional and accepted by PCA, exclusion zones or “no go” areas will be established to protect critical habitat or areas with known residences (e.g., hibernacula, dens, nests).

- If recommended by a Qualified Professional and accepted by PCA, conduct “Pre-stressing” activities within a few days prior to the onset of site preparation to encourage wildlife to move away from a site. The need for, type and frequency of pre-stressing activities will consider:
  - The amount and quality of information available about wildlife;
  - The size of the area to be affected;
  - The proposed timing of project works and activities (i.e., within or outside of prescribed timing windows);
  - The need for multiple pre-stressing events.
- On a daily basis, an inspection or “sweep” of the work area shall be performed prior to commencement of project works and activities to ensure wildlife is not present in the work area. A site inspection checklist shall be included in the site-specific EMP and accepted by PCA.
- Animals should be provided a safe corridor to escape and/or move around the construction site. Corridors designed to facilitate species movement should be a minimum of 50 m to 100 m in width.
- Any proposed material changes to the EIA or EMP must be reviewed and accepted by PCA.

#### Wildlife Protection Best Practices

- All vehicles and equipment used by project personnel will follow construction zone speed limits to reduce the risk of hitting wildlife, as enforced by the site supervisor.
- Camps and associated infrastructure will be designed to exclude wildlife. Options include security fencing, regular snow removal, covering vents with wire mesh to exclude small mammals and birds, and metal mesh skirting around elevated trailers, walkways, and stairs to prevent wildlife access. Fencing should be tailored to the wildlife expected on-site. Fencing will be used to prevent wildlife from entering waste storage areas. See Tree Protection and Hording (ESG-4-Pre) for guidelines regarding exclusion fencing.
- Work areas will be kept clean and free of potential hazards to wildlife such as wire, cable, tubing, plastic, antifreeze or other materials that wildlife may eat or become entangled in.
- Waste will be stored, handled, and transported in accordance with the Waste Management Plan included in the site-specific EMP, including external storage of all solid waste in sealed, bear-proof containers. Proper food storage/cleanup of all wildlife attractants. Avoid littering, keeping all trash secured in wildlife-proof containers and promptly remove waste from site especially in warm weather.
- Feeding of wildlife is prohibited.
- Hunting or trapping by project personnel is prohibited.

#### Encounters with Wildlife (SAR and/ non-SAR)

The following procedures shall be followed for incidental encounters with all species, including SAR

- For a SAR, immediately cease activity within the work area of the encounter;
  - Immediately notify site supervisors and PCA and prepare a report to PCA;
  - Do not approach or handle the species (i.e., do not harm or harass the species);
  - Identify the individual species and determine species status.



- For mobile species:
  - Provide 24 hours and a safe corridor for species to leave the area before continuing the activity. If the species does not leave the site within 24 hours and work must proceed in the area of the encounter, take measures to relocate the species to a nearby suitable location.
  - Only a Qualified Professional should handle or relocate species.
- For injured species:
  - Take measures to ensure the species is protected from further harm (e.g. provide operator/worker awareness to avoid the location of the encounter).
  - Contact a Qualified Professional to determine and implement required actions (e.g., if feasible, the capture and relocation of an injured species to an appropriate care facility by the Qualified Professional).
  - Do not perform any work in the immediate location of the encounter until the species is removed from further harm.
  - Species handling and relocation measures will be based on the Ontario Species at Risk Handling Manual and will be implemented by, or under the guidance of the Qualified Professional.
- For a nest or breeding site of a species:
  - Stop work within 100 m and consult with a Qualified Professional.
  - Contact a Qualified Professional to determine whether the nest is active or inactive.
  - Notify PCA immediately of the nest status.
  - If active, mark an area at the location of the encounter around the nest and implement protective measures. Ensure that the nest is not more identifiable to predators.
  - Monitor the species to ensure it is not stressed or disturbed, including not disturbing its habitat. If the species appears stressed or disturbed cease operations immediately and contact a Qualified Professional for direction.
  - If a protected underground nest has been exposed, ensure it is covered with the same material and to the same depth if appropriate.
  - If it is necessary to remove a nest to proceed with work, contact the Qualified Professional to determine options for removal in accordance with the legislation and regulation (including the *Migratory Birds Convention Act*) and to determine consultation requirements with regulatory agencies.
  - Understand the nesting periods of various species.
- For species giving live birth, with eggs, or young:
  - Mark an area at the location of the encounter in a way that will protect the species from harm and will not identify the species to predators.
  - Contact the Qualified Professional to determine and implement required actions.
  - Monitor the species to ensure it is not stressed or disturbed, including not disturbing its habitat. If the species appears stressed or disturbed cease operations immediately and contact a Qualified Professional for direction.
  - Species handling and relocation measures will be based on the Ontario Species at Risk Handling Manual and will be implemented by, or under the guidance of the qualified biologist.
- For hibernating species:
  - Contact a Qualified Professional to determine how work may proceed. If the species must be relocated, obtain a SAR permit to proceed.





- Species handling and relocation measures will be based on the Ontario Species at Risk Handling Manual and will be implemented by, or under the guidance of the qualified biologist.
- For mosses, lichens, or vascular plant species:
  - Mark and protect the area at the location of the encounter in a way that will protect the species from harm and will not identify the species to predators.
- For reptile and amphibian species:
  - Contact a Qualified Professional to determine how to proceed.
  - Turtles can often be gently moved to a safe location nearby. Wear gloves or use a broom to steer the turtle in the direction of safety.
  - Exclusion fencing shall be used to eliminate access to specific area where activities could harm animals are occurring.
  - Exclusion fence design should consider the target species as well as those that might be unintentionally impacted. Fencing material should not pose a risk of entanglement or permit individuals to pass under or between openings.
  - For short-term activities (<6 months), a light-duty geotextile fence is appropriate and for longer term or permanent fencing projects, a more durable material such as heavy-duty geotextile, wood, concrete, woven-wire etc. would be appropriate.
  - Geotextile fencing with nylon mesh lining should be avoided due to the risk of entanglement by snakes.
  - To deter digging, bury the fence at least 10 cm down with an additional 10 cm horizontal lip. For snakes and toads, the fence should have an overhanging lip on the species side.
  - Exclusion fences should be installed prior to emergence from hibernation. Once the fence is installed, a survey should be done to ensure that no individuals have been trapped inside.
  - Fences should be inspected at regular intervals throughout the active season, especially following heavy rain events.
- For any other wildlife species:
  - No shut down is required unless young are present or animals do not calmly move away.
  - Provide the animal with a safe corridor to escape.
  - If young are present, stop construction activities within 100 m of sighting until animal moves away.
  - If a bear is detected within 1 kilometer away from the work area, issue an alert to all workers.

#### SAR Protection Measures

- The site-specific EMP must reflect the project as designed for implementation and the most current Species at Risk (SAR) records.
- Prior to any physical works or activities to be conducted on the project site, the Historic Canals Regulations permit for the project, and the site-specific EMP accepted by PCA should be reviewed to confirm if any SAR and/or habitat may be present and potentially affected by project works and activities.
- If SAR and/or habitat are present and are likely to be affected by the project, the SAR mitigation measures identified in the EIA and accepted site-specific EMP must be implemented, with special emphasis on:
  - the construction timing windows identified in the Project's EIA;
  - tailoring protection measures to wildlife seasonal patterns; and



- the implementation of any protection measures aimed at excluding wildlife species from the work area, minimizing disturbance/harm and any “no go” areas aimed at excluding project works activities from species habitats.

### SAR Training and Awareness

All personnel conducting work on the site should be provided with SAR information and/or awareness training so they are familiar with the SAR procedures for the work, including reporting requirements. A record of all persons provided information and awareness training should be kept. The information and training should include:

- Obligations under the SARA;
- Information about the specific species that may be present in the work area;
- How to identify the species;
- Habitat characteristics for the species/where species are likely to be found;
- Potential threats and impacts to the species; and
- EMP commitments regarding SAR protection, including the SAR encounters procedure.

### Recording and Reporting

- For all wildlife encounters, the following information should be recorded in the field:
  - Locations, dates and time of day where species at risk were encountered;
  - the names of species encountered;
  - photographs of the species, if taken.
  - Condition of the animal.
- PCA shall be notified immediately if injured/dead wildlife are encountered. PCA may require retrieval and storage on ice of carcass for laboratory testing.
- Field information regarding incidental encounters with wildlife (non-SAR wildlife) shall be compiled and reported on a monthly daily basis.
- To document that the SAR encounter procedure has been followed for the purpose of demonstrating compliance, record and make available the following information:
  - A description of the work or activity being undertaken;
  - The locations, dates and times of day the activity was undertaken;
  - A list of SAR potentially affected and its condition / status during the encounter;
  - All measures implemented to avoid or minimize harm; including specific locations the best practices process was implemented;
  - The Qualified Professional assisting in implementation;
  - The duration of the work stoppage; and
  - The restart and completion dates of the activity at each location.

### Related Environmental Standards and Guidelines

- General Environmental Protection Procedures
- Erosion Control (ESG-1-Pre)
- Sediment Control (ESG-2-Pre)
- Vegetation Clearing and Protection (ESG-5-Pre)
- Invasive Species Management (ESG-11-C)
- Revegetation (ESG-1-Post)



### *Related EMP Component Plans*

- Dust and Air Quality Management
- Noise, Vibration and Ambient Light Management
- Site Dewatering and Wastewater Plan
- Vegetation Protection
- Wildlife Protection and Management
- Aquatic Resources Management
- Species at Risk Protection
- Invasive Species Management
- Spills Prevention and Emergency Response
- Site Restoration

### *Other Design and Environmental Considerations*

- For sites located within or adjacent to existing developed areas, nearby residents should be informed about the onset of pre-stressing activities and the potential for increased encounters with wildlife dispersing from the site. Local noise by-laws shall be respected.
- Scratches and bites from animals, whether domestic or wild, can result in serious infections and/or transmit diseases. Immediate medical treatment should be sought for any person injured by an animal.

### *Further Guidance*

Environment and Climate Change Canada, 2017. General Nesting Periods of Migratory Birds in Canada. Available at: <http://www.ec.gc.ca/paom-itmb/default.asp?lang=En&n=4F39A78F-1#cn-tphp>

Ontario Ministry of Natural Resources and Forestry, 2016. Best Management Practices for Mitigating the Effects of Roads on Amphibian and Reptile Species at Risk in Ontario.

Ontario Ministry of Natural Resources and Forestry, 2013. Species at Risk Branch Best Practices Technical Note: Reptile and Amphibian Exclusion Fencing. Version 1.1. Available at: [http://files.ontario.ca/environment-and-energy/species-at-risk/mnr\\_sar\\_tx\\_rptl\\_amp\\_fnc\\_en.pdf](http://files.ontario.ca/environment-and-energy/species-at-risk/mnr_sar_tx_rptl_amp_fnc_en.pdf)

Ontario Ministry of Transportation, 2016. MTO Best Management Practices for Species at Risk Protection during Maintenance Activities. Draft for Comment, November 18, 2016.

Ontario Ministry of Natural Resources and Forestry. Ontario Species at Risk Handling Manual: For *Endangered Species Act* Authorization Holders. Available at: [http://files.ontario.ca/environment-and-energy/species-at-risk/mnr\\_sar\\_tx\\_sar\\_hnd\\_mnl\\_en.pdf](http://files.ontario.ca/environment-and-energy/species-at-risk/mnr_sar_tx_sar_hnd_mnl_en.pdf)

### *References*

City of Ottawa, 2015. Ottawa Region Best Management Practices for Wildlife During Construction. Available at <http://ottawa.ca/en/wildlife-strategy-city-ottawa/wildlife-construction-protocol>

Environment and Climate Change Canada, 2013. How Much Habitat is Enough? Third Edition. Environment Canada, Toronto, Ontario. Available at: <https://www.ec.gc.ca/nature/default.asp?lang=En&n=E33B007C-1>



# Winter Weather Stabilization and Operations (ESG-18-C)

---

## Application to Ontario Waterways' Projects

Winter weather stabilization activities are critical to projects that carry over more than one construction season or require construction during the winter. Heavy accumulation of snow in disturbed areas or poor snow management practices can create blowing snow that reduces visibility or lead to severe erosion and sediment transport during temporary thaws or during the spring melt. Heavy truck and equipment traffic over unprotected and recently thawed or wet ground can create deep ruts that could divert or hold meltwater. Water accumulation can freeze creating a slippery ice hazard.

## Description of Activity

Winter weather stabilization or winterization activities involve preparing disturbed areas and erosion and sediment control features for effective operation during winter, temporary thaws and during the spring melt. Winter operations involve snow and meltwater management through plowing, dozing and/or storing snow on the site and measures to prevent excessive snow accumulation and uncontrolled meltwater.

## Environmental Standards and Guidelines

- All construction sites must be winterized no later than November 15 of each year.
- No fish salvage operations shall be undertaken after freeze-up or November 15 of each year.
- Areas of a construction site that will remain **inactive** over winter (i.e., where construction activity will not occur), must meet the following winterization requirements:
  - Install and maintain effective temporary erosion and sediment control devices prior to ground freezing.
  - Stabilize all disturbed and bare soil areas with native vegetation, mulch, hydro-mulch with a tackifier or erosion control blankets. See Erosion Control ([ESG-1-Pre](#)) and Sediment Control ([ESG-2-Pre](#)).
  - All mulch applied during winter shall be anchored. Installing erosion control blankets is not recommended on frozen ground or if more than one inch of snow is present.
  - Cover soil stockpiles to be used next season with mulch or plastic sheeting and contain within sediment fencing. Sediment fences shall not be installed when frozen conditions prevent proper embedment.
- All drainage ditches, swales, berms and channels should be constructed and stabilized prior to ground freeze. Temporary stabilization shall be undertaken using stone or erosion control blankets appropriate for the design flow conditions, as determined by a Qualified Professional.
- All spills on snow, ice or frozen ground shall be cleaned-up immediately and reported.
- Ice shall not be used as a catchment area for construction debris (concrete rubble/dust, gravel, etc.)
- Frozen materials that are removed during winter construction, should be stockpiled separately from previously excavated materials in a designated location.
- Prior to the onset of a forecasted thaw and following each rainfall, or thaw period, the site Contractor shall conduct an inspection of all installed erosion and sediment control devices and



perform repairs as needed to ensure they function as required. If supplementary ditching or berming needs to be constructed this shall be done before melt starts to prevent flooding.

- For any area stabilized by temporary or permanent seeding prior to the onset of the winter season, the Contractor should conduct an inspection in the spring to ascertain the condition of vegetation cover, and repair any damaged areas or bare spots and reseed as required to achieve an established vegetative cover (at least 85% of area vegetated with healthy, vigorous growth).

### *Snow and Meltwater Management*

- The storage and application of road salt for de-icing purposes is prohibited. Only environmentally friendly sand and de-icing products approved by PCA shall be used at a construction site. Grit and deicers should be ordered and on-site prior to first snow fall, usually in September. Follow manufacture's specifications for application of de-icing products.
- Accumulated snow shall be removed from active construction work areas prior to significant earth-moving activities when accumulations reach up to 30 cm.
- Utilize snow blowers, snowploughs or other equipment to remove snow into windrows or to move snow to designated storage areas. Do not pile snow on erosion sensitive areas. These areas should be identified in the EMP. For snow windrows, gaps would be left at natural drainage swales to allow for cross drainage.
- Designated snow disposal areas within the site shall be identified in the EMP. They should be clearly delineated in a way that is easily identifiable under adverse winter conditions, to ensure that the snow is placed in the proper location on the site.
- Snow storage areas should be designated in locations where soil rutting will not be an issue otherwise storage areas shall be constructed with a solid base as designed by a Qualified Professional (e.g., Geotechnical engineer).
- All excavations occurring through the winter season should be marked with high visibility markers, blinking lights or bermed / barricaded. Snow cover can hide leading edges of excavations causing deep holes to look like shallow depressions.
- Remove equipment and supplies from flood prone areas prior to snow melt or spring thaw.
- To avoid flooding during spring melt, snow disposal areas should not be placed on high ground. Site meltwater should be directed away from the snow piles and dumping area to reduce ponding/rutting.
- Remove snow accumulations from around flow conveyance structures such as culverts and ditches following major snowfalls to minimize ice jamming or structure failure during freeze-thaw cycles.
- Install snow fences in areas where snow drifts of more than 1.5 m in depth can occur. Snow fences should be between 1.5 to 2.0 m in height, placed at a distance of 15 to 20 times the fence height from the area to be protected.
- Prior to spring melt, review the site's surface water management plan and ensure that planned water run-off areas are still appropriate. If supplementary ditching or berming needs to be constructed, this should be done before melt starts to prevent flooding.

### *Related Environmental Standards and Guidelines*

- General Environmental Protection Procedures
- Erosion Control (ESG-1-Pre)
- Sediment Control (ESG-2-Pre)
- Fish Exclusion, Salvage and Relocation (ESG-7-C)
- Refueling and Spill Management (ESG-13-C)
- Revegetation (ESG-1-Post)



### *Related EMP Component Plans*

- Transportation Management
- Demolition
- Site Dewatering and Wastewater Management
- Surface Dewatering and Wastewater Plan
- Aquatic Resources Management
- Waste Management
- Hazardous Materials Management
- Fuel Management
- Spills Prevention and Emergency Response

### *References*

Transportation Association of Canada, 2013. Syntheses of Best Practices Road Salt Management - Snow Storage and Disposal. April 2013. Available at: <http://www.tac-atc.ca/en/bookstore-and-resources/free-resources-and-tools/syntheses-practice>

Hawryluk, T., 2014. Winter Works Best Practice. Available at: <https://www.coaa.ab.ca/COAA-Library/SAF-WTW-PBP-01-2014-v1%20Winter%20Works%20with%20Appendices.pdf>



# Revegetation (ESG-1-Post)

---

## Application to Ontario Waterways' Projects

Site preparation for a construction project on PCA property will require vegetation removal (i.e., clearing and grubbing) to prepare laydown areas, storage areas, camps, access roads/trails etc. Riparian and aquatic vegetation removal may also be necessary for in-water works (e.g., bridge and dam sites, water crossings). Revegetation is required as part of site restoration. Revegetation covers many different habitat types, boreal, St. Lawrence lowlands, Carolinian, manicured, open/savannah, riparian, etc.

## Description of Activity

Revegetation is a key component of site restoration. Revegetation stabilizes soil, reduces erosion and sediment runoff, and inhibits growth of invasive species. Revegetation involves providing a suitable growing medium for vegetation. Revegetation can include reseeding and replanting of shrubs and trees. There are two approaches to seeding: 1) temporary seeding for short-term exposed soils and 2) long-term seeding associated with site restoration. Replanting of shrubs and trees is undertaken for long-term site restoration following the completion of construction works and activities.

## Environmental Standards and Guidelines

### General

- All proposed revegetation measures shall be described in the site-specific EMP and accepted by PCA.
- Develop revegetation objectives in terms of short-term and long-term goals (revegetation plan in EMP provided to PCA):
  - Short Term: stabilize the ground surface at all disturbed areas.
  - Long Term: restore the site and work areas to a specific future state or for a specific end use (e.g., public use, recreation, wildlife habitat), including any remediation, if required.
- Native species to Ontario will be used when revegetating sites, with the exception of sod. Species will be appropriate for site conditions and habitat. Invasive species will not be used.
- Necessary erosion and sedimentation control practices should be established prior to seeding.
- Optimal timing for seeding is early spring (before spring runoff) or fall; however, seeding can occur throughout summer with irrigation.

### Soil De-compaction

- De-compact soil which has been compacted from the movement of construction equipment and project staging.
  - The most effective way to manage soil compaction on construction sites is to avoid compacting the soil in the first place. This can be accomplished by dedicating access and haul routes and restricting access to areas of the site that are more susceptible to compaction such as clay soils and wet soils. All site entrances will be identified in the site-specific EMP and accepted by PCA.



- Topsoil stripping and stockpiling should be employed at all construction sites where heavy machinery, continuous lightweight traffic, equipment storage or stockpiling of materials is anticipated. See Soil Stripping, Grubbing and Stockpiling, [ESG-3-C](#).
- Areas that have been compacted or had the topsoil layer removed must be decompacted and amended by reapplying topsoil, the addition of compost or through other techniques that are capable of mitigating lost moisture holding capacity.
- Prior to de-compaction activities, the location of all buried utilities must be determined. Avoid de-compaction of soils in areas that have buried utilities, wires, pipes, culverts, or diversion channels.
- Soil de-compaction is most effective when the ground is dry. This is especially important for clay soils.
- Perform ripping operations during late summer or fall to take advantage of the relatively dry seasonal conditions while allowing soil settling for early spring tree planting.
- When ripping is performed on nearly level ground, the direction of ripping is not critical. However, when ripping is performed on slopes, it is advisable to rip along the contour to minimize erosion. Once soil has been decompacted follow up immediately with topsoil placement and seeding/erosion control or sod as per the specifications.
- It is recommended to following ground contours whenever possible when performing de-compaction to increase water capture, protect run-off quality, and reduce soil erosion.
- Decompaction becomes increasing important in relation to the root depth of the vegetation being planted as part site restoration. Deeper rooted plants such as shrubs and trees require deeper de-compaction to facilitate healthy root penetration and vigorous growth. Ensure that de-compaction depth is consistent with the revegetation plan.
- Placement of topsoil over disturbed lands shall be undertaken to provide a suitable growing medium for revegetation plant species and site conditions. Most of the soil to be used for this purpose should come from on-site topsoil stockpiles (See Invasive Species Management [ESG-11-C](#)). Typically, topsoil is not applied to slopes greater than 2:1.
- Suitable sub-soils must also be used for revegetated areas if the native fill has been removed. Revegetation will follow the poorly drained soil requirements in the table below.
- The following minimum depths of growing medium should be achieved to the extent possible (given soil availability and site conditions).

<b>Application</b>	<b>Over Prepared Sub-grade, retaining the "A" horizon</b>	<b>Over rapidly draining soil</b>	<b>Over poorly draining soil</b>
Lawns	100 mm	150 mm	225 mm
Ground Cover Areas	150 mm	300 mm	225 mm
Small Shrubs	300 mm	450 mm	225 mm
Large Shrubs	450 mm	600 mm	450 mm
Trees	600 mm	600 mm	600-900 mm

- Mulch will be applied to areas where invasive plants have been removed. Areas where mulch has been displaced by a rainfall event or high winds should be repaired when conditions allow.
- Any seeding requires some form of erosion protection product (e.g., compost, mulch, erosion control blanket) in order to minimize disturbance and provide immediate stabilization while establishment occurs. See Erosion Control ([ESG-1-Pre](#)).





- Where a seedbed cannot be prepared properly, hydromulching, compost shall be used on slopes up to 1.5:1 or for anything steeper, an anchored rolled erosion protection measures (see Erosion Control ESG-1-Pre) shall be used. Hydromulching may also be used where seedbeds may retain large clods of soil or rocks, and on sites where other soil stabilising, seeding, and mulching practices would not be effective due to unacceptable levels of surface soil disturbance. See Erosion Control (ESG-1-Pre) and Sediment Control (ESG-2-Pre) for further guidance on hydromulching and required thickness for slopes.
- Revegetation of all exposed soils shall be undertaken using Ontario native seed mixes, as soon as practicable and accepted by PCA, to reduce the risk of soil erosion and sedimentation.
- Sod can be used at lock stations where areas are expected to be mowed. Any areas where plants will be left to go to seed, then Ontario native species must be used.
- Seeding shall be undertaken on slopes of 3:1 or less. For greater slopes, hydraulic seeding is recommended.
- Native Ontario seed mixes should be applied at a rate that produces a seedling density such that each seedling develops into a viable reproducing plant. Some species require only small quantities of seed. According to the Ontario Construction Specification for Seeding and Mulching, Temporary Cover, and Erosion Control Blanket, the minimum rate of seed application for standard roadside, salt tolerant, lowland or acidic soil mix should be 100 kg/ha and for crown vetch or birdsfoot trefoil mix the rate is 75 kg/ha.
- Bags of commercial seed are frequently sources of non-native invasive species. Only certified, weed-free seed will be used.
- Areas that fail to establish adequate cover, or have been invaded by weedy species shall be reseeded. Spot seeding can be done on small areas to fill in bare spots where seed did not germinate. Successful re-vegetation is considered once seeded/planted species have reached a ground cover of 80%.
- Where shrubs and/or deciduous trees were present along a watercourse or wetland prior to construction, willow stakes, red-osier dogwood, aspen, and other riparian trees and shrubs will be implanted in moist soils along the edge up to 20 m of the width of the clearance area and for the full area of work areas to stabilize disturbances and reduce sedimentation.
- All tree and shrubs planted should be covered by mulch (the size of planted root ball) with a well around the trunk to allow for water infiltration.
- The use of fertilizers is prohibited. Compost will be considered the first option where fertilizers would otherwise be utilized. Compost must be weed-free or from a facility where temperatures have rendered seeds non-viable.
- Ensure Qualified Professional(s) complete post-construction vegetation monitoring to ensure success of revegetation.
- During the establishment period of the new plants, the plants will need to be watered (weather dependant) at minimally every 7 to 10 days or preferably every 2-3 days between May and August 30, and minimally every 14 to 21 days between September 1 and November 15.
  - Watering should be enough to penetrate the full depth of the growing medium.
  - Soil moisture should be monitored throughout the growing season and the frequency of watering should be increased when plant materials are reaching the permanent wilting point. Scheduled applications of water should be skipped when rainfall has penetrated the soil fully.



### *Related Environmental Standards and Guidelines*

- General Environmental Protection Procedures
- Erosion Control (ESG-1-Pre)
- Sediment Control (ESG-2-Pre)
- Soil Stripping, Grubbing and Stockpiling (ESG-3-Pre)
- Vegetation Clearing and Protection (ESG-4-Pre)
- Invasive Species Management (ESG-11-C)

### *Related EMP Component Plans*

- Vegetation Protection
- Wildlife Protection and Management
- Species at Risk Protection
- Invasive Species Management
- Site Restoration

### *Other Design and Environmental Considerations*

- Necessary erosion and sedimentation control practices should be established prior to seeding.
- Optimal timing for seeding is early spring (before spring runoff) or fall; however, seeding can occur throughout summer with irrigation.
- Timing of works should avoid seasonally high rainfall and snowmelt periods.

### *Further Guidance*

Landscape Ontario Horticultural Trades Association, 2004. Landscape Guidelines. Available at: [http://landscapeontario.com/attach/1246977850.Landscape\\_Guidelines.pdf](http://landscapeontario.com/attach/1246977850.Landscape_Guidelines.pdf).

TRCA. 2010. Preserving and Restoring Healthy Soil: Best Practices for Urban Construction. Version 1.0. June 2012. Available online: [www.conservationhalton.ca/.../preserving\\_and\\_restoring\\_healthy\\_soil\\_trca\\_2012.pdf](http://www.conservationhalton.ca/.../preserving_and_restoring_healthy_soil_trca_2012.pdf)

### *References*

Kees, 2008. Using Subsoiling To Reduce Soil Compaction; USDA Forest Service Technology and Development Program Missoula, MT 5E52F74 Soil Tilth Restorer

Government of Yukon, 2011. Best Management Practices for Works Affecting Water in Yukon. Water Resources Branch, Environment Yukon. May 2011. ISBN 978-1-55362-525-4.

Government of Ontario. 1990. Contract Design, Estimating and Documentation – Special Provisions Volumes, Seeding and Cover. August 1990. Index 572S01. Available online: <http://www.raqsa.mto.gov.on.ca/techpubs/cdedspa.nsf/83b14ef9766e4ae385257081006823bb/ecb4894b75949c39852568070076d35e?OpenDocument>

Minnesota Stormwater Manual, 2016. Alleviating Compaction from Construction Activities; URL: [https://stormwater.pca.state.mn.us/index.php?title=About\\_the\\_Minnesota\\_Stormwater\\_Manual&oldid=21614](https://stormwater.pca.state.mn.us/index.php?title=About_the_Minnesota_Stormwater_Manual&oldid=21614)

Virginia Department of Conservation and Recreation (VA-DCR), 2011. Virginia DCR Stormwater Design Specification No. 4: Soil Restoration, <http://vwrrc.vt.edu/swc/>.



## **APPENDIX A**

### **Glossary and Acronyms**



Word/Acronym	Acronym	Definition
Adaptive Management		A planned and systematic process for continuously improving environmental management practices by learning about their outcomes.
Angular gravel		Typically 14 to 20 mm in size and most suitable for driveways as the pieces lock together when driven on so are less likely to rut. Also referred to as Flint or Golden Spa gravel.
ATV	ATV	All-Terrain Vehicle
By-pass Channel		An alternate passage created to carry excess water from river or channel while work is being completed on a portion of the river or channel.
Capital Plan		A plan for four to ten years identifying projects that will help maintain or improve City assets, providing a planning schedule and identifies option for financing the plan.
CEAA	CEAA	<i>Canadian Environmental Assessment Act</i>
CEPA	CEPA	<i>Canadian Environmental Protection Act</i>
CO2	CO2	Carbon Dioxide
Coffer dam		A watertight enclosure pumped dry to permit construction work below the water line.
Compaction (soil)		Soil compaction is the process in which a stress applied to a soil causes densification as air is displaced from the pores between the soil grains.
Component plans		As part of a broader Environmental Management Plan, a highly specific plan aimed at providing guidance regarding how a specific project work, activity would be undertaken or how an objective would be achieved.
Compost blankets		A layer of loosely applied composted material placed on the soil in disturbed areas to reduce storm water runoff and erosion.
Cut slope roughening		Creating a rough soil surface to reduce the speed of runoff, increase infiltration and trap sediment. This helps establish vegetative cover by reducing runoff velocity and thus reducing erosion.
Cutoff walls		An area of reclamation separated by an impervious material.
DBH	DBH	Unit of measure applied to mature trees - diameter at breast height.



Word/Acronym	Acronym	Definition
Deleterious substances		A substance which when introduced to fish bearing waters is one that will harm fish or fish habitat.
Drip-line		The area defined by the outermost circumference of a tree canopy where water drips from and onto the ground.
Dust suppressants		Water or chemical compounds that are finely sprayed on a surface to eliminate or minimize dust generation.
EA	EA	Environmental Assessment
Earthworks		Activities that include grading, excavation, backfilling in connection to a construction project.
ECCC	ECCC	Environment and Climate Change Canada
EIA	EIA	Environmental Impact Assessment
Environmental Management Plan	EMP	An EMP is a project-specific and site-specific document, based on the site-specific EIA, that contains a set of over-arching EMP requirements plus a set of highly specific component plans that, when implemented collectively as a management system, are intended to avoid, eliminate or reduce the severity of adverse environmental effects.
Energy dissipation		Equipment or structures used where concentrated flows are discharged into a natural or manmade drainage feature such as a stream, wetland, lake, or ditch, typically applied at the outlets of ponds, pipes, drains, culverts, ditches, or other conveyances.
EPA	EPA	Effective Project Approval
Erosion		The gradual process of degrading soil as a result of wind, water or other natural agents.
Erosion control blanket	ECB	A degradable rolled erosion control product composed of processed natural or polymer fibers mechanically, structurally or chemically bound together to form a continuous matrix to provide erosion control and facilitate vegetation establishment.
ESG	ESG	Environmental Standards and Guidelines
ESSB	ESSB	Explosives Safety and Security Branch



Word/Acronym	Acronym	Definition
Fiber roll		A temporary erosion control and sediment control device used on construction sites to protect water quality in nearby streams, rivers and lakes from sediment erosion. It is made of straw, coconut fiber or similar material formed in a tubular roll.
Fish salvage		The physical removal of fish from an isolated in-water work area, aimed at removing fish, using non-lethal methods, from construction areas and releasing them downstream or elsewhere with minimal handling.
Flumes		An artificial narrow channel conveying water through it.
Fugitive dust		Visible emissions of particulate matter released from sources other than stacks, typically dust blown from storage piles, roads, and areas of disturbed soil.
Grubbing		The activity of digging out or mulching in-situ stumps and roots below the ground surface. The removal of visible rocks and boulders is often undertaken while grubbing.
HASP	HASP	Health and Safety Plan
High water mark	HWM	The water level reached by a lake or river at its highest stand.
Hoarding		A temporary wooden or metal structure placed around a building or structure under construction or repair or around trees or other areas to be protected from encroachment by construction personnel or equipment.
HVAC	HVAC	Heating, ventilation and air conditioning
HVLP	HVLP	High volume low pressure
Hydromulching		A one-step process where seed, fertilizer and mulch and a binder are combined together in water. The resulting slurry is sprayed onto the soil surface providing a wood fiber interlocking mat that retains moisture for seed germination.
Industrial Health and Safety Plan		A plan listing how worker safety, health and welfare will be maintain during a project.
Invasive species		Non-native species to an ecosystem whose introduction causes or is likely to cause environmental harm.



Word/Acronym	Acronym	Definition
In-water works		Construction work which occurs in a watercourse or waterbody (e.g., canal).
Isolated piers		Piers are vertical structures made from brick, concrete, block, stone, timber or steel which supports floor structures. An engaged pier is a pier that is bonded to a wall while an isolated pier is separate from a wall.
Land-Based Activities		Construction work which occurs primarily on land.
MSDS	MSDS	Material Safety Data Sheet
Mud Mats		Used for construction site access and other soft or sensitive ground condition areas where vehicle access is required. They can be unrolled on any muddy or swampy ground and driven over without rutting, getting stuck or tracking mud off-site.
Noise abatement		A set of strategies to reduce noise pollution or to reduce the impact of that noise.
Notional approval		The approval of a concept or idea.
Noxious weeds		A plant species that has been designated by an agricultural authority as one that is injurious to agricultural or horticultural crops, natural habitats or ecosystems or humans or livestock.
NRCan	NRCan	Natural Resources Canada
NTU	NTU	Nephelometric Turbidity Unit, measure of turbidity
Off-road compression-ignition engine emission regulations (SOR/2005-32)		The Off-Road Compression-Ignition Engine Emission Regulations (the Regulations) introduced emission standards for diesel engines used in off-road applications such as those typically found in construction, mining, farming and forestry machines.
OMRF	OMRF	Ontario Ministry of Natural Resources and Forestry
Ontario Ambient Air Quality Criteria	AAQC	A desirable concentration of contaminant in air, based on protection against adverse effects on health or the environment. The term ambient is used to reflect general air quality independent of location or source of a contaminant.
Ontario Regulation 347		An Ontario regulation on waste management.



Word/Acronym	Acronym	Definition
Ontario Waterways		Lands and waters in the Rideau Canal and Trent-Severn Waterway owned and administered by Parks Canada Agency
OPSD	OPSD	Ontario Provincial Standards
OPSS 120.04		Ontario Provincial Standard Specification for general specification for the use of explosives.
OPSS 201 Guideline for clearing, close cut clearing, grubbing, removal of boulders and mechanical stump cutting		Ontario Provincial Standard Specification for the construction specification for clearing, close cut clearing, grubbing and removal of surface boulders.
OWA	OWA	Ontario Waterpower Association
Oxy-acetylene torch		A cutting and welding process that uses fuel gases and oxygen to weld and cut metals.
PCA	PCA	Parks Canada Agency
Peak particle velocity		The maximum speed of a particular particle as it oscillates about a point of equilibrium that is moved by a passing wave.
Performance Criteria		Standards by which performance is evaluated.
pH	pH	Unit of measure - potential of hydrogen, which is measure of the degree of acidity or alkalinity
Physiographic regions		A definition of the earth's landforms into distinct regions based upon the tree-tiered approach that further defines landforms.
PPA	PPA	Preliminary Project Approval
Pre-stressing activities		In the context of environmental protection, the activity of temporarily disturbing wildlife to encourage them to vacate an area
PTTW	PTTW	Permit to take Water
Qualified Professional	QP	Typically an engineer, applied scientist or technologist who is registered and in good standing with an appropriate professional organization or who, through demonstrated experience and knowledge relevant to the particular matter, may be reasonably relied on to provide advice within their area of expertise. Such a professional could be an ecologist / biologist, forester, geoscientist, engineer, or technologist.
Riparian		The banks of a river





Word/Acronym	Acronym	Definition
Rock check dam		A small rock dam constructed across a drainage way, swale or road ditch to counteract erosion by reducing water flow velocity.
Rolled erosion control products	RECP	Rolled erosion control products consist of prefabricated blankets or netting which are formed from both natural and synthetic materials to provide erosion control.
RPA	RPA	Requests for Project Approval
SAR	SAR	Species at Risk
SARA	SARA	<i>Species at Risk Act</i>
SEC	SEC	Sediment and Erosion Control
Sediment bags		A filter for silt laden water from construction sites. As water from the construction site is pumped into the bag, sediment is collected by the fabric allowing filtered water to pass through.
Sediment fence		A temporary sediment barrier, typically comprised of a permeable geotextile fabric designed to intercept and slow the flow of sediment-laden runoff from areas of disturbed soil.
Sediment ponds		A temporary pond built on a construction site to capture eroded or disturbed soil that is washed off during rain storms, and protect the water quality of nearby stream, river or lake. The sediment-laden soil settles in the pond before the runoff is discharged.
Sediment traps		Instruments used to measure the quantity of sinking particulate material in an aquatic system.
Sedimentation		The tendency for particles in suspension to settle out of the fluid in which they are entrained and deposit or accumulate against a barrier.
Seine nets		A fishing net that hangs vertically in the water with its bottom edge held down by weights and its top edge buoyed by floats.
Shock-tubes		An instrument used to replicate and direct blast waves at a sensor or a model in order to simulate actual explosions and their effects on a smaller scale.



Word/Acronym	Acronym	Definition
Siltsoxx		A tubular mesh sediment-trapping device which uses filter media materials applied with a pneumatic blower device or equivalent.
Soil horizon		A layer generally parallel to the soil crust, whose physical characteristics differ from the layers above and beneath. Each soil type usually has three or four horizons. Horizons are defined in most cases by obvious physical features, chiefly colour and texture.
SPEC	SPEC	Specifications
Stripping		The disturbance and removal of topsoil.
Surveillance monitoring		Compliance monitoring or site inspection
Tackifiers		A chemical compound used in formulating adhesives to increase the tack, the stickiness of the surface of the adhesive.
<i>TDG</i>	<i>TDG</i>	<i>Transportation of Dangerous Goods Act</i>
Timing windows		A time interval in which construction can occur.
Total suspended particulate	TSP	A measure of mass concentration of particulate matter in air
Tremie concrete pours		A method which uses a pipe, through which concrete is placed below water level. The lower end of the pipe is kept immersed in fresh concrete so that the rising concrete from the bottom displaces the water without washing out the cement content.
UNESCO World Heritage Site		A place that is listed by the United Nations Education, Scientific and Cultural Organization as of special cultural or physical significance.
Vehicular tracking control	VTC	Provides stabilized construction site access where vehicles exit the site onto paved public roads. It helps remove sediment from vehicles, reducing tracking onto the paved surface.
Wash-down Area		An area of a construction site, typically located at an access points, constructed and equipped to remove debris and sediment from tires and undercarriages of vehicles or other equipment to prevent sediment from entering a watercourse or waterbody or from being transported onto public roadways.



**APPENDIX B**  
**Policy and Legislative Context for Projects on Ontario Waterways**



## APPENDIX B: POLICY AND LEGISLATIVE CONTEXT FOR PROJECTS ON ONTARIO WATERWAYS

### **B.1. PCA Policies**

PCA has developed a comprehensive set of Guiding Principles and Operational Policies which give direction to current and future programs, initiatives and projects on Ontario Waterways. These guiding principles and policies are centered on the goals and values of Parks Canada articulated in their mission statement:

*"Building our future together - strengthening a shared sense of Canadian identity which respects the diversity of the land and the people" (Parks Canada, 2013).*

PCA's vision is to protect heritage areas through stewardship, citizen awareness and the protection of their ecological and commemorative integrity. PCA's activities entail direct responsibility for the management of federal lands and their associated assets and natural resources. This is the case for national parks, aspects of marine conservation areas and a number of national historic sites, including historic canals such as the Rideau Canal and the Trent-Severn Waterway (Parks Canada, 2013).

PCA, its Contractors or their agents must have regard for PCA's policies. The following sections summarize key PCA's policies that may apply to projects on Ontario Waterways.

#### ***Historic Canals Policy***

As a result in the change of use of canals in Canada from commercial transportation to heritage appreciation, the Government of Canada transferred the responsibility for a number of operating canals in the 1970's from the Minister of Transport to the Minister responsible for Parks Canada. The objective of the Historic Canals Policy is to:

*"foster appreciation, enjoyment and understanding of Canada's historic canals by providing for navigation; by managing cultural and natural resources for purposes of protection and presentation; and by encouraging appropriate uses" (Parks Canada, 2009).*

Any project on Ontario Waterways will require careful consideration of navigation. The following considerations will guide the provision of navigation: availability of adequate water levels, maintenance of public safety, preservation of heritage character, physical condition of the works, time of year, demand, and available human and financial resources. It is PCA's objectives to maintain adequate canal water depths, structures and navigation aids in order to provide for navigation.

#### ***Policies for In-Water and Shoreline Works Related Activities***

PCA's Ontario Waterways Unit has developed policies for In-Water and Shoreline Works Related Activities<sup>4</sup> that provide guidance for a variety of construction activities which may be proposed along the canals. This policy applies to the following:

---

<sup>4</sup> For a detail description on each of these policies, refer to Parks Canada website: <http://www.pc.gc.ca/eng/docs/r/poli/page01.aspx>



- Docks and Boatlifts
- Boathouses and Boat Ports
- Dredging including the removal or relocation of logs, stumps or rock
- Shoreline Stabilization
- Beach Creation
- Inland Boatslips and Mooring Basins
- Launch Ramps
- Marine Railways
- Heat Pump Loops
- Waterlines
- Mooring Buoys, Swimming Buoys, Rafts and Water Ski Courses and Ramps
- In-Water and Shoreline Works in Narrow Channels
- In-Water and Shoreline Works in Wetlands.

These policies for In-Water Works and Shoreline Works can also be considered as Best Practices.

### ***Cultural Resource Management Policy***

PCA has developed a Cultural Resource Management Policy to assist in the management of cultural resources, including historic canals, in accordance with the principles of value, public benefit, understanding, respect and integrity. In the design and construction of projects on Ontario Waterways, reasonable precautions will need to be taken by Contractors and their agents to ensure that PCA continues to:

- provide for navigation;
- manage cultural and natural resources for purposes of protection and presentation; and
- encourage appropriate uses of federal lands and resources.

### ***Green Energy Development***

PCA is working with Ontario Waterpower Association (OWA) to optimize water power production and expanding Green Energy development opportunities<sup>5</sup>. PCA has also made available select sites that are suitable for hydro development applications. The process to permit, licence, and generate electricity through water power is extensive and ensures that the needs of many partners are met, including the PCA, the Province of Ontario, the environment, the water power industry and, ultimately, the Canadian public.

PCA's historic canals are important to the waterpower industry, and a major employer. The historic canals and local economies benefit directly from the revenue derived from waterpower generation, which is reinvested back into the canals to support their long-term sustainability.

## **B.2. Federal Legislation**

PCA, its Contractors or their agents must have regard for, and remain in compliance with all applicable federal legislative requirements throughout the duration of any project, from its initial design through construction, project completion / close-out. Specifically, a Contractor's Environmental Management Plan (EMP) will need to demonstrate their understanding of the

---

<sup>5</sup> Parks Canada (2016). Trent-Severn Waterway National Historic Site: Green Energy Development on Parks Canada's Historic Canals in Ontario. Available online: <http://www.pc.gc.ca/eng/lhn-nhs/on/trentsevern/plan/energie-verte-green-energy.aspx>



legislative context and how their proposed works and activities will be undertaken to ensure compliance.

### ***Parks Canada Agency Act***

The *Parks Canada Agency Act*<sup>6</sup> (1998) is administered by Environment and Climate Change Canada (ECCC). The *Act* established the Parks Canada Agency for the purpose of ensuring that Canada's national parks, national historic sites and related heritage areas are protected and presented for this and future generations. All work completed in water and on land within historic canals are under the authority of PCA.

### ***Canada National Parks Act***

The *Canada Parks Act*<sup>7</sup> (2000) is administered by the PCA. The *Act* states that national parks are for the benefit, education and enjoyment of the Canadian people and the parks shall be maintained and made use of as to leave them unimpaired for future enjoyment. While the *Canada National Parks Act* does not specifically apply to Historic Canals, the *Act* and its regulations are often used by PCA as guidance regarding various standards, design, materials, construction and maintenance activities that may be undertaken on Historic Canals.

### ***Historic Canals Regulations***

The Historic Canals Regulations<sup>8</sup> under the *Department of Transport Act* is administered by the PCA. The Regulations are intended to assist in the maintenance, management and protection of historic canals. Authorization for work to be completed in water and on land within historic canals is under the authority of PCA. Contractors and their agents will require a permit from PCA prior to the commencement of any physical works or activities on the Rideau Canada and/or the Trent-Severn Waterway. The permit will be based on the EIA and the accepted EMP. The regulation gives PCA's the authority to issue a stop work order if the work fails to comply with the terms and conditions specified in the permit.

### ***Navigation Protection Act***

The *Navigation Protect Act* is administered by Transport Canada. The *Act* was established to protect transportation along Canada's navigable waterways listed in Schedule of the *Act*. Many of the waterways listed in the schedule to the *Act* are within the Rideau Canal and Trent-Severn Waterways. Authorization for work completed in water and on land within the listed canals is not required if a permit under the Historic Canals Regulations has been issued.

---

<sup>6</sup> *Parks Canada Agency Act* (S.C. 1998, c. 31). Available from the Department of Justice Canada website: <http://laws-lois.justice.gc.ca/eng/acts/P-0.4/index.html>

<sup>7</sup> *Canada National Parks Act* (S.C. 2000, c. 32). Available from the Department of Justice Canada website: <http://laws-lois.justice.gc.ca/eng/acts/N-14.01/>

<sup>8</sup> Historic Canals Regulations (SOR/93-220) (last amended June 5, 2015). Available from the Department of Justice Canada website: <http://laws-lois.justice.gc.ca/eng/regulations/SOR-93-220/index.html>



## **CEAA 2012**

The *Canadian Environmental Assessment Act, 2012*<sup>9</sup> is administered by the Canadian Environmental Assessment Agency. The *Act* was established to protect the environment from significant adverse environmental effects caused by a designated project and to ensure that designated projects are considered in a careful and precautionary manner to avoid significant adverse environmental effects. Currently, none of the projects subject to this ESG Document are “designated projects”, although future projects may be added to the Designated Project list. Under Section 67 of the CEAA 2012, all projects on federal lands must not result in significant adverse environmental effects, or if there are significant adverse effects those effects must be justified in the circumstances. PCA will ensure that an Environmental Impact Analysis (EIA) is undertaken for projects on the Rideau Canal and Trent-Severn Waterway in accordance with PCA’s EIA procedures and that a determination is made regarding if the project can proceed. Additional details are available in PCA’s “Guide to the Parks Canada Environmental Impact Analysis Process”<sup>10</sup> (June 2015). No construction can begin until an EIA is approved by PCA.

Contractors and their agents will need to ensure that all mitigation measures identified in the approved EIA are implemented and effective as they are the requirements under which the assessment has concluded that there will likely be no significant adverse effects.

## **Fisheries Act**

The *Fisheries Act*<sup>11</sup> is administered by the Fisheries and Oceans Canada (DFO). The *Act* was established to protect fish and fish habitat by prohibiting work or the deposition of a deleterious substance that results in serious harm to fish that are part of a commercial, recreational or Aboriginal fishery, or to fish that support such fishery unless the work is completed in accordance with prescribed conditions within a DFO authorization.

Should PCA determine that serious harm to fish is likely, PCA will send the Projects to DFO for project review and possible authorization. Residual serious harm to fish will need to offset in accordance with an approved offsetting plan. DFO requires all information stated in Schedule 1 of the *Fisheries Act* to begin a *Fisheries Act* review. This process may take up to 60 days. If a *Fisheries Act* authorization is required there is an additional 90 days to issue an authorization from the date all information is provided including an approved offsetting plan. An EIA cannot be approved until there is a *Fisheries Act* authorization.

Contractors and their agents will be required to comply with all provisions of any authorization issued by DFO or other measures identified by PCA intended to protect fish and fish habitat. These measures will need to be included in an EMP.

---

<sup>9</sup> *Canadian Environmental Assessment Act, 2012* (S.C. 2012, c. 19, s. 52). Available from the Department of Justice Canada website: <http://laws-lois.justice.gc.ca/eng/acts/c-15.21/FullText.html>

<sup>10</sup> “Guide to the Parks Canada Environmental Impact Analysis Process” June 2015. Available from Parks Canada Agency’s website: <http://www.pc.gc.ca/progs/eie-eia/itm1/itm1b/itm1b-2.aspx>.

<sup>11</sup> *Fisheries Act, 2012* (R.S.C., 1985, c. F-14). Available from the Department of Justice Canada website: <http://laws-lois.justice.gc.ca/eng/acts/F-14/>



### **Species at Risk Act**

The *Species at Risk Act*<sup>12</sup> (SARA) is administered by Environment and Climate Change Canada, but Parks Canada is the competent minister for all PCA lands and waters. The *Act* was established to prevent wildlife species from being extirpated or becoming extinct, to provide for the recovery of wildlife species that are extirpated, endangered or threatened as a result of human activity and to manage species of special concern to prevent them from becoming endangered or threatened.

SARA imposes obligations on federal land management agencies. As such, PCA has the responsibility for implementing SARA for those species at risk that occur on federal lands it administers, including species of fish (as defined by SARA) and of migratory birds.

PCA evaluates the impact on species listed under the *Act* whenever it grants a formal permit, or undertakes work that has the potential to affect species or habitats. Similarly, an authorization under SARA is required before any authorization such as a lease, license, or permit can be issued if the activity being authorized may affect an individual of a species listed in Schedule 1 of the *Act* or the critical habitat of the species. PCA may require follow-up and monitoring to be undertaken that is consistent with relevant species' recovery strategies and action plans, and the objectives, scope, timelines and responsibilities for monitoring activities outlined in the EIA report<sup>13</sup>.

Contractors and their agents will be required to comply with all provisions of any permits issued by PCA and include measures to protect species at risk within an EMP.

### **Migratory Birds Convention Act**

The *Migratory Birds Convention Act*<sup>14</sup> is administered by Environment and Climate Change Canada. The *Act* was established to implement the Convention by protecting and conserving migratory birds as populations and as individual birds and their nests. In general, projects affecting migratory birds, their nests, egg or egg shelter are protected under the *Act*. The discovery of a migratory bird's nest could result in a temporary shutdown of construction until a process for mitigation can be agreed to with Parks Canada and Environment and Climate Change Canada. During construction, no substances shall be deposited that may be harmful to migratory birds.

Contractors and their agents will be required to comply with all provisions of any permits issued under the *Act* and include measures to protect migratory birds within an EMP.

---

<sup>12</sup> *Species at Risk Act* (S.C. 2002, c. 29). Available from the Department of Justice Canada website: <http://laws-lois.justice.gc.ca/eng/acts/s-15.3/>

<sup>13</sup> For further information, please consult "Addressing *Species at Risk Act* Considerations Under the *Canadian Environmental Assessment Act* for Species Under the Responsibility of the Minister Responsible for Environment Canada and Parks Canada" and "*Species at Risk Act* Guidelines - Guidelines for Permitting Under Section 73 of the *Species at Risk Act*"

<sup>14</sup> *Migratory Birds Convention Act* (S.C. 1994, c. 22). Available from the Department of Justice Canada website: <http://laws-lois.justice.gc.ca/eng/acts/M-7.01/FullText.html>





### **Canadian Environmental Protection Act**

The *Canadian Environmental Protection Act*<sup>15</sup> (CEPA), 1999, is administered by Environment and Climate Change Canada. The *Act* was established to contribute to sustainable development through pollution prevention and to protect the environment, human life and health from the risks associated with toxic substances.

Contractors and their agents must be in compliance with the *Act* by ensuring that any relevant policies, guidelines, codes of practice, government notices and orders which may affect the construction work are considered in project planning and design, or referenced within an EMP.

### **Transportation of Dangerous Goods Act**

The *Transportation of Dangerous Goods Act*<sup>16</sup>, (TDG) 1992, is administered by Transport Canada. The *Act* was established to promote public safety in the transportation of dangerous goods (e.g., explosives, gases, flammable liquids and solids). Under the Historic Canals Regulations (see above) no person in charge of a vessel shall allow the vessel to transport any dangerous goods as defined in the *TDG Act* in a historic canal, except in accordance with a permit issued by PCA.

Contractors and their agents will be required to comply with all provisions of any permit issued by PCA or other measures identified by PCA intended to protect public safety in the transportation of dangerous goods. These measures will need to be included in an EMP.

### **Explosives Act**

The *Explosives Act*<sup>17</sup> is administered by the Explosives Safety and Security Branch (ESSB) of Natural Resources Canada (NRCan). The *Act* was established to respecting the manufacture, testing, acquisition, possession, sale, storage, transportation, importation and exportation of explosives and the use of fireworks. Any work on land or in the water in the canals which may require explosives for construction (i.e., blasting) will require a permit or licence.

Contractors and their agents may be required to submit permit applications and will be required to comply with all provisions of any permit issued by NRCan or other measures identified by PCA intended to protect public safety and the environment from blasting activities. These measures will need to be included in an EMP.

## **B.3. Provincial Legislation**

In general, Provincial legislation is not applicable to projects undertaken on federal lands. Nevertheless, PCA, its Contractors or their agents should be aware and have regard for Provincial legislative requirements throughout the duration of any project, from its initial design through construction, project completion / close-out. There may also be circumstances where certain project works or activities are undertaken on non-federal lands (e.g., private or municipal

---

<sup>15</sup> *Canadian Environmental Protection Act* (S.C. 1999, c. 33). Retrieved from the Department of Justice Canada website: <http://laws-lois.justice.gc.ca/eng/acts/c-15.31/FullText.html>

<sup>16</sup> *Transportation of Dangerous Goods Act*, 1992 (S.C. 1992, c. 34). Retrieved from the Department of Justice Canada website: <http://laws-lois.justice.gc.ca/eng/acts/T-19.01/>

<sup>17</sup> *Explosives Act* (R.S.C., 1985, c. E-17). Retrieved from the Department of Justice Canada website: <http://laws-lois.justice.gc.ca/eng/acts/E-17/FullText.html>



leased properties, Provincial Crown lands). In such instances, Provincial legislative requirements would apply. Key Provincial legislation that may require consideration during and EIA and throughout project delivery include:

### ***Ontario Environmental Assessment Act***

The *Ontario Environmental Assessment Act* is administered by the Ontario Ministry of the Environment and Climate Change. The *Act* is not applicable to PCA projects conducted on federal lands. However, some projects on Ontario Waterways may involve or otherwise interact with other proposed projects subject to the *Ontario Environmental Assessment Act*. These other projects may be proceeding as either Individual Environmental Assessments, an EA process defined by an approved Class Environmental Assessment (Class EA) or other form of Provincial EA (e.g., Class Environmental Assessment for Resource Stewardship and Facility Development Projects; Class Environmental Assessment for Waterpower Projects).

### ***Ontario Endangered Species Act***

The *Ontario Endangered Species Act*<sup>18</sup> is administered by the Ontario Minister of the Natural Resources and Forestry (OMRF). The *Act* identifies species at risk, protects species that are at risk and their habitats and promotes the recovery of species that at risk. The *Act* is not applicable to PCA projects conducted on federal lands, however PCA is to have regard for endangered species identified by the Province that are not listed under the federal SARA.

### ***Ontario Invasive Species Act***

The *Ontario Invasive Species Act*<sup>19</sup>, 2015, is administered by the Ontario Minister of the Natural Resources and Forestry (OMNRF). The *Act* provides rules to prevent and control the spread of invasive species in the natural environment. Specific provisions apply to the release of invasive species into Provincial Park or conservation reserve. The *Act* is not applicable to PCA projects conducted on federal lands; however PCA is to have regard for the *Act* and associated guidance materials.

### ***Lakes and Rivers Improvement Act***

The *Lakes and Rivers Improvement Act*<sup>20</sup> is administered by the Ontario Minister of the Natural Resources and Forestry. The *Act* provides rules for the management, protection, preservation and use of the waters of the lakes and rivers of Ontario and the land under them and the use of the fish, wildlife and other natural resources dependent on the lakes and rivers. The *Act* does not apply to PCA projects conducted on federal lands.

---

<sup>18</sup> *Endangered Species Act* (S.O. 2007, CHAPTER 6). Retrieved from the Ontario e-Laws website: <https://www.ontario.ca/laws/statute/07e06#top>

<sup>19</sup> *Invasive Species Act* (S.O. 2015, c. 22). Retrieved from the Ontario e-Laws website: <https://www.ontario.ca/laws/statute/15i22>

<sup>20</sup> *Lakes and Rivers Improvement Act* (R.S.O. 1990, c. L.3). Retrieved from the Ontario e-Laws website: <https://www.ontario.ca/laws/statute/90l03>



### **Ontario Water Resources Act**

The *Ontario Water Resources Act*<sup>21</sup> is administered by the Ontario Minister of Environment and Climate Change. The purpose of the *Act* is to provide for the conservation, protection and management of Ontario's waters and for their efficient and sustainable use, in order to promote Ontario's long-term environmental, social and economic well-being. The *Act* prohibits discharges (or permitting the discharge) of any material of any kind into or in any waters or on any shore or bank or into any place that may impair the quality of the water of any waters. The *Act* also requires a permit to take water (PPTW) for takings of more than 50,000 L of water on any day by any means except in accordance with a permit issued.

The following water takings related to construction site dewatering and road construction may be eligible for registration in the Environmental Activity and Sector Registry (EASR):

- Surface water takings related to specific road construction purposes; and
- Ground water and/or storm water takings of more than 50,000 L/day but less than 400,000 L/day for the purposes of construction site dewatering.

For an activity to be exempted as a water taking and not require a PPTW, all conditions for the exemption must be met. Further information can be found in The Water Taking User Guide for Environmental Activity and Sector Registry<sup>22</sup> and Ontario Regulation 387/04<sup>23</sup>.

### **Ontario Environmental Protection Act**

The *Environmental Protection Act*<sup>24</sup> is the principal pollution control statute in Ontario. It is used interchangeably with the *Ontario Water Resources Act* to address sources of water pollution. The *Act* contains a number of general provisions that can be used to protect surface water and groundwater against contamination. Primarily, the *Environmental Protection Act* prohibits discharges of contaminants into the natural environment in an amount, concentration or level in excess of prescribed regulatory standards. The *Act* is also where regulations establishing the Environmental Activity and Sector Registry (EASR) have been enacted.

### **Ontario Conservation Authorities Act**

The *Ontario Conservation Authorities Act*<sup>25</sup> is administered by the Ontario Minister of Natural Resources and Forestry. The *Act* established and governs all Conservation Authorities in Ontario. The *Act* gives Conservation Authorities jurisdiction over one or more watersheds and the ability to enforce regulations in order to ensure a complete and rational approach to issues

---

<sup>21</sup> *Ontario Water Resources Act* (R.S.O. 1990, c. O.40). Retrieved from the Ontario e-Laws website: <https://www.ontario.ca/laws/statute/90o40#BK0>

<sup>22</sup> [The Water Taking User Guide](https://www.ontario.ca/page/water-taking-user-guide-environmental-activity-and-sector-registry) for Environmental Activity and Sector Registry. Available at: <https://www.ontario.ca/page/water-taking-user-guide-environmental-activity-and-sector-registry>

<sup>23</sup> *Ontario Regulation 387/04*. Retrieved from the Ontario Laws website: <https://www.ontario.ca/laws/regulation/040387>

<sup>24</sup> *Ontario Environmental Protection Act* (R.S.O. 1990), c. E.19. Retrieved from the Ontario Laws website: <https://www.ontario.ca/laws/statute/90e19>

<sup>25</sup> *Ontario Conservation Authorities Act* (R.S.O. 1990, Chapter C.27). Last amendment: 2011, c. 9, Sched. 27, s. 22. Retrieved from the Ontario Laws website: <https://www.ontario.ca/laws/statute/90c27#BK0>



such as flood protection and erosion control. This *Act* becomes relevant for all non-federal land that may be leased by Contractors.

#### **B.4. Municipal Requirements**

The *Ontario Municipal Act* is the main statute governing the creation, administration, governance of municipalities in Ontario, and Ontario's *Planning Act* affords municipalities a major role in local planning decisions. The Ministry of Municipal Affairs promotes infrastructure planning, environmental protection, economic development and safe communities, but it is the municipality's responsibility to execute this through municipal planning decisions identified in the Official Plans and through municipal by-laws. Common by-laws include by-laws for zoning, tree cutting, noise, water and sewage, waste disposal.

While municipal requirements are not applicable on federal lands, there may be instances where a project requires municipal or private lands off federal property, where the project relies on municipal services (e.g., waste management, water and sewage, storm sewers, electric utilities, fire and emergency services, roads/transportation) or where project effects (e.g., noise, dust, traffic) extend off-site.



**APPENDIX C**  
**Parks Canada Agency's Environmental Impact Assessment Process**



## APPENDIX C: PARKS CANADA AGENCY'S ENVIRONMENTAL IMPACT ASSESSMENT (EIA) PROCESS

Under Section 67 of *CEAA 2012* PCA has a legal responsibility to ensure that projects and activities undertaken on the lands it manages do not result in significant adverse environmental effects. These include the project and activities undertaken at the National Historic Sites of the Rideau Canal and the Trent-Severn Waterway.

### **C.1. Environmental Impact Assessment Process**

The objective of Parks Canada's Environmental Impact Assessment (EIA) process is to ensure project review is conducted efficiently and that effort is focused on projects with the greatest potential to significantly affect the integrity of natural or cultural resources or characteristics of the environment that are important to key visitor experience objectives.

A project will not occur until an EIA has been completed, approved and the results taken into account in decision-making. It is the responsibility of the project proponent (i.e., either PCA itself or an external organization) to follow the PCA EIA process and gain the necessary approvals for the project to proceed.

***Project proponents, contractors or their agents may be requested to assist PCA in making their determination regarding the most appropriate EIA pathway through the preparation of an initial project description and/or design documents that describe the physical works and activities to be undertaken and any project features aimed at avoiding or minimizing adverse environmental effects.***

No EIA is required if an initial analysis completed by PCA determines that the proposed project is not likely to cause adverse effects to natural or cultural resources, or characteristics of the environment that are important to key visitor experience objectives, and the potential for effects does not require further investigation. An EIA is also not required if the proposed project is being prepared in response to a clear and immediate emergency (e.g., dam failure) where there is insufficient time to undertake an EIA. No EIA is required if the proposed project was part of another project that was previously assessed in sufficient detail.

If the initial analysis determines that a proposed project is likely to cause adverse effects on natural or cultural resources, or on characteristics of the environment important to key visitor experience objectives, it will be assigned to one of the four (4) EIA pathways deemed by Parks Canada to be the most appropriate for addressing the potential environmental effects. These are described below. Parks Canada has developed an EIA Decision Framework and associated criteria to guide their decision-making on specific projects and taking into consideration site-specific circumstances.



### **1. Alternative Process**

PCA's EIA requirements may be fulfilled through the application of an alternative process that has been approved as fulfilling EIA requirements by PCA. Currently, no such process exists for typical projects on Ontario Waterways, however in some cases, Provincial EAs (i.e., Individual or Class EAs) may be considered as meeting PCA's EIA requirements.

In any case, PCA determines, in accordance with its legal obligation, whether the project may cause significant adverse environmental effects. Taking into account the information available to PCA and other considerations as appropriate to the proposed project, a project would only proceed if it is determined not to cause significant adverse effects. Prior to approving a project, Parks Canada must ensure the EIA adequately meets *SARA* and *Fisheries Act* requirements.

### **2. Best Management Practices**

In addition to the Environmental Standards and Guidelines presented in this ESG Document, PCA has developed a number of other Best Management Practices (BMPs) as pre-determined environmental management and mitigation measures for a defined class of routine, repetitive projects with well understood and predictable effects.

Parks Canada may determine that the measures presented in this ESG Document and/or other BMPs shall be applied in whole, or in part, as mitigation for a proposed project. In circumstances where potential environmental effects can be fully addressed through the application of these measures, no additional EIA may be required.

Parks Canada will inform a proponent if a proposed project is subject to BMPs and will provide BMPs along with any project-specific clarifications or additions as appropriate.

In some circumstances accepted Environmental Standards and Guidelines and BMPs may only address a portion of the potential effects associated with a project. In these cases, Parks Canada will advise proponents regarding the potential application of these measures in association with the requirements for these other EIA paths as appropriate.

### **3. Basic Impact Analysis (BIA)**

A Basic Impact Analysis (BIA) is typically undertaken where:

- The adverse effects are predictable and well understood;
- The adverse effects will be confined to the project site or immediate surroundings;
- Mitigation measures and impact management techniques are familiar;
- There is minimal potential for contributing to cumulative adverse effects to the integrity of ecological and cultural resources, or to environmental components critical to visitor experience;
- There is little or no need for follow up monitoring; and
- There is normally no need to consult the public.



BIAs are typically conducted using a standard template or form. The template documents how a proposed project may interact with valued environmental components, identifies any applicable Standards or Guidelines and BMPs, and identifies other site and project-specific mitigation or other measures (e.g., follow-up and monitoring) as needed to ensure that the project does not result in significant adverse environmental effects.

Although a BIA does not typically require public or stakeholder consultation, PCA may conduct engage the public and stakeholder in the preparation and/or review of the BIA, at its discretion.

Following completion of the draft BIA, Parks Canada will determine, in accordance with its legal obligation, whether the project may cause significant adverse environmental effects. Taking into account the BIA and other considerations as appropriate to the proposed project, a project would only proceed if it is determined not to cause significant adverse effects. Prior to approving a BIA, Parks Canada must ensure the BIA adequately meets *SARA* and *Fisheries Act* requirements.

#### **4. Detailed Impact Analysis (DIA)**

A Detailed Impact Analysis (DIA) is typically undertaken where the proposed project may potentially result in significant adverse effects, and/or public concern with respect to ecological integrity, the integrity of cultural resources or characteristics of the environment that are important to key visitor experience objectives.

PCA has developed criteria that are used to guide the decision-making as to whether a proposed project should be required to undergo a DIA. Examples relevant to projects on Ontario Waterways include:

- Projects likely to result in the substantive alteration of water level, flow or management regime in a water body, or result in other important changes to surface or groundwater resources;
- Projects involving new or expanded roads, including operational service or access roads or crossing structures;
- Projects likely to change the nature and experience of unique, iconic or otherwise valued environmental components characteristic of wilderness, the natural environment, or the historical and cultural significance of a protected heritage place; and
- Projects likely to adversely affect the integrity of level 1 cultural resources.

DIAs are typically conducted on the basis of a project description (as necessary, such as when more detailed project design information becomes available) and a Terms of Reference (ToR) prepared by Parks Canada.





A DIA would specifically address all items identified in the ToR, but would typically include the following:

- A description and comparison of feasible alternatives to be assessed, as specified in ToR;
- A description of existing or baseline environmental conditions, supported by additional research or field work, as identified in the TOR;
- A description of potential environmental effects of the project including the integrated consideration of cumulative effects;
- The development of mitigation measures including improvements or modifications to designs, plans or implementation procedures;
- A prediction of residual impact based on desired conditions or outcomes including integrated consideration of cumulative effects;
- An assessment of the significance of the predicted residual adverse effects; and
- The identification of any follow-up or monitoring required.

PCA may conduct engage the public and stakeholder in the preparation and/or review of the DIA, as outlined in the ToR.

Following completion of the draft DIA, Parks Canada will determine, in accordance with its legal obligation, whether the project may cause significant adverse environmental effects. Taking into account the DIA and other considerations as appropriate to the proposed project, a project would only proceed if it is determined not to cause significant adverse effects. Prior to approving a DIA, Parks Canada must ensure the DIA adequately meets *SARA* and *Fisheries Act* requirements.

The need for the public and/or stakeholders to be informed of and otherwise engaged in a project EIA will be considered at the outset of the EIA process. Parks Canada must engage in additional and separate consultations with Aboriginal groups if there is a possibility of a project, adversely affecting established or potential Aboriginal or Treaty rights. The requirement for consultation with Aboriginal peoples is determined as early as possible during an EIA. PCA will consult and collaborate with relevant departments and jurisdictions as appropriate when a project may have adverse effects outside of the lands and waters it administers.



**APPENDIX D**  
**Typical Project Works and Activities on Ontario Waterways**



## APPENDIX D: TYPICAL PROJECT WORKS AND ACTIVITIES ON ONTARIO WATERWAYS

PCA undertakes a wide variety of projects on Ontario Waterways in order to maintain and operate their marine and land-based assets. Many of PCA assets on Ontario Waterways were constructed between the 1950's and 1970's with some of the most historic and culturally valuable assets were constructed the early 1800's through to the early 1900's. As such, they require substantial work to maintain their physical integrity, function and commemorative value. The potential environmental effects of such projects are vast and varied and inevitably very site-specific (i.e., dependent on the nature of the local environmental and socio-economic setting) and project-specific (i.e., dependent on the nature, scale, timing and design of the project).

In most cases, PCA projects on Ontario Waterways tend to involve a set of common works and activities during the **site preparation** phase:

- **Vegetation Removal** (e.g., clearing, grubbing) at a construction site is often undertaken to prepare laydown areas, storage areas, camps, access roads/trails. Vegetation removal involves stripping of the ground cover; felling, trimming, and cutting of trees and shrubs; and, other the removal (e.g., downed timber, snags, brush, and rubbish) occurring within areas to be cleared. Grubbing involves digging out or mulching in-situ stumps and roots below ground surface. This would include removal of visible rocks and boulders. Riparian and aquatic vegetation removal may also necessary for in-water works (e.g., bridge and dam sites, water crossings). In some cases, this would involve removal of natural vegetation, while in others this may require removal of lawns (e.g., at lock stations).
- **Earthworks** (e.g., excavation, grading) are undertaken to prepare laydown areas, storage areas, camps, access roads/trails allow construction equipment and personnel access to structures (e.g., lock or approach walls, bridge abutments, dam foundations, etc.) to be repaired or upgraded. Top soil is stripped and excavated materials may be stockpiled for future backfilling or site restoration. Earthworks are also required for major construction activities that require the removal of overburden to allow for construction of foundations or supports on bedrock. In some instances existing shoreline protection measures such as 'rip-rap' or armour stone may need to be removed.
- **Installation and Removal of Sediment and Erosion Control and Water Quality Protection Measures** are undertaken. This involves installing measures that prevent sediment laden waters from ground disturbance or other project activities from entering the aquatic environment. Measures may range from physical devices such as sediment controlling fencing and mats to re-vegetation, hydro seeding and tackifiers. Water treatment measures may involve the installation and/or use of filter bags, settling ponds, silt curtains, fractionation tanks etc.
- **Dewatering** may need to be undertaken for repairs and upgrades of canal locks by draining or pumping water out of the lock or from below a coffer dam. Similarly, dewatering may involve dam and flume operations to divert water away from work areas near locks, dams and bridges. In some instances, dewatering may be required to remove groundwater to permit excavation and construction below grade.
- **Installation and Removal of Cutoff Walls, Cofferdams or By-Pass Channels** may be required to provide a dewatered area upstream and/or downstream of the lock, dam



or other structure or surrounding a bridge abutment or support, if work is occurring in these areas. By-pass or water diversion channels may need to be installed to accommodate minimum flow requirements during the construction period.

- **Fish Passage, Salvage and Relocation** measures are typically undertaken in conjunction with coffer dam installations and dewatering operations.

Locks are typically concrete, brick and/or stone chambers with gates and sluiceways that allow the chamber to be drained and filled with water. Along many sections of the Rideau Canal or Trent-Severn Waterways, there are many locks at a given lockstation. They may be pedestrian or vehicular bridges (fixed or swing bridges; headrace and weir bridges) constructed from concrete, metal and/or wood. The physical works and activities undertaken during the **construction phase** for lock, bridge or concrete dam repair or upgrade projects on Ontario Waterways typically involve:

- **Demolition and/or Dismantling** of major structural features at locks, dams and bridges such as concrete foundations and other structures such as gates, spillways, sluices etc. Demolition materials may be temporarily stored on-site, salvaged or transported off-site for recycling or disposal.
- **Concrete Removal** from lock chamber walls, dam structures, bridge abutments and supports. Additional removal of concrete from areas where concrete removal and repair is required may include monoliths, approach and retaining walls, stairs, and floors. This may involve removal of chipped concrete, parging and other small eroded areas of the concrete surfaces by chipping, cutting and/or sandblasting.
- **Concrete Application and Minor Re-construction** may involve repairing concrete by applying new coping concrete, pouring concrete formwork and curing, deck pours, pouring concrete formwork underwater, concrete placement by pump, underwater pour by tremie, concrete/masonry repair, replacing grout, pointing stone, cutting back the surface of concrete structures. Major concrete works involve forming and repouring of foundations and structures at their original location or total replacement of entire sections of concrete or concrete structures.
- **Repair, Salvage and/or Reinstallation of Ancillary Equipment** is often undertaken for lock and dam gates and arms; various swing bridge mechanical components; lock and dam scramble ladders, handrails/railings, wooden/metal decking, roller assemblies, mooring cleats/cables; anchor bolts, lock and dam signage. Repairs may involve metal work (e.g., grinding and welding), cleaning and/or painting of the equipment.

Earth dams may require repairs and/or upgrades to increase their heights/widths and to strengthen them by addressing washouts and/or removing vegetation. Some vegetation may loosen the soil in the dam creating seepage paths that can lead to internal erosion and vulnerabilities in the embankment. In some instances, earth dam repairs may also involve works and activities similar to concrete dam repairs (see above). Gravel roads that service PCA assets such as locks, bridges and dams may also require repairs and upgrades involving similar works and activities. The physical works and activities undertaken during the **construction phase** for earth dam and gravel road repair or upgrade projects on Ontario Waterways typically involve:



- **Transport and Stockpiling of Earth, Aggregate and/or Clean Fill** will often be required to increase the heights/widths of earthen dams. Stockpiling could be undertaken on-shore or on the existing dam structure itself.
- **Designated Vegetation Removal** (e.g., stripping clearing, grubbing) on an earthen dam site is often undertaken by stripping of the ground cover in designated areas; felling, cutting of designated trees and shrubs; and, digging out stumps and roots below ground surface.
- **Earth, Aggregate and/or Clean fill Placement** involves transfer, placement and compaction of materials at specific locations along the dam that are subject to repair or upgrade. This may be on the dam surface or along its embankments. Holes created by removal of trees or shrubs would be filled.

Concrete dam replacement projects involve either reconstruction in-situ or reconstruction downstream. Reconstruction in-situ typically involves the removal of the existing dam and construction of a new dam at the same location, and isolation of the work area from the Waterway with cofferdams or by-pass channels. Reconstruction Downstream involves construction of a new dam immediately downstream of the existing dam and isolation of the work area from the Waterway with cofferdams or by-pass channels. The existing dam could either be partially or fully removed. The physical works and activities undertaken during the **construction phase** for concrete dam replacement projects (e.g., in-situ or downstream replacements) on Ontario Waterways typically involve:

- **Demolition and/or Dismantling** of major structural features at the existing dam such as concrete foundations, gates, spillways, sluices etc. Demolition materials may be temporarily stored on-site, salvaged or transported off-site for recycling or disposal.
- **Blasting or Drilling** may be required during the demolition of existing dam structures and/or to prepare foundations and footings for the new dam structure.
- **Concrete Pouring and Dam Reconstruction** involves preparing reconstruction forms, re-enforcing steel placement, and concrete pouring for approach walls, piers, dam foundations and primary structures.
- **Installation of Ancillary Equipment** involves gates and arms; various swing bridge mechanical components; lock and dam scramble ladders, handrails/railings, wooden/metal decking, roller assemblies, mooring cleats/cables; anchor bolts, lock and dam signage. Repairs may involve metal work (e.g., grinding and welding), cleaning and/or painting of the equipment.

In most cases, PCA projects on Ontario Waterways tend to involve a set of common works and activities during the **site restoration** phase:

- **Backfilling** of excavated areas and other earthworks are undertaken to restore the ground surface to its original or to establish desired slopes and surface drainage patterns. In some cases, restoration would re-establish erosion protection measures (e.g., river stone, riprap) along exposed banks and shorelines susceptible to erosion.
- **Site restoration** activities typically involve removal of temporary vegetation protection measures (e.g., hoarding), reseeding, placement of sod, replanting of ground cover, trees and shrubs.