

2
A103

SOUS-SOL DU GRAND HALL
NIVEAU - 3000

1
A104

L'ESCALIER DE LA ROTONDE (NON INCLUS AU CONTRAT)
NIVEAU - 6 000

1
A102

LA GALERIE (NON INCLUS AU CONTRAT)
NIVEAU - 6 000

1
A103

L'ESCALIER DU GRAND HALL
NIVEAU - 6 000

1
A101

LA COLONNADE
NIVEAU - 4 000

MUSÉE DES BEAUX-ARTS DU CANADA - PLAN CLÉ
1 : 1000

1
A100

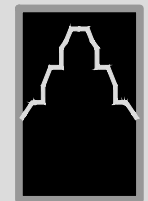

Musée des beaux arts du Canada
A100 - PLAN CLÉ, AUX NIVEAUX 4 000 À 6 000
ÉCHELLE 1 : 1000

Mises à jour du Code de construction – Phase II
A100

LE 15 FÉV. 2017
Moshe Safdie and Associates, Inc.

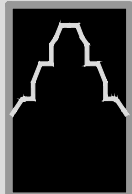
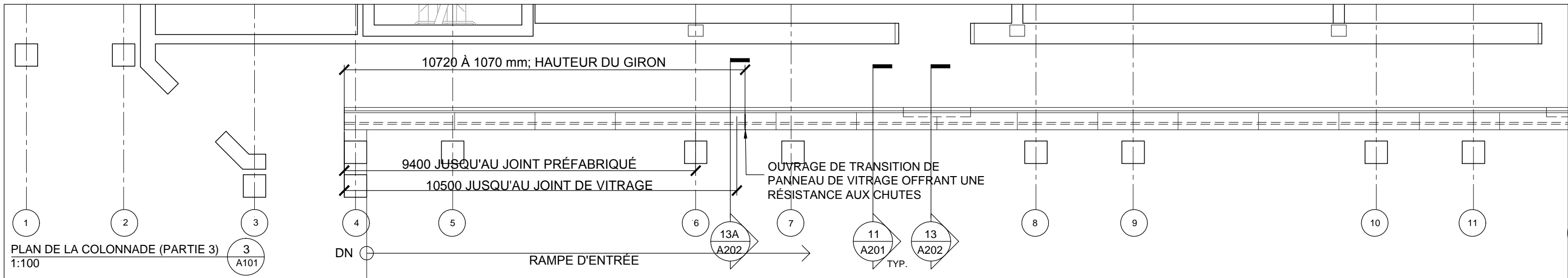
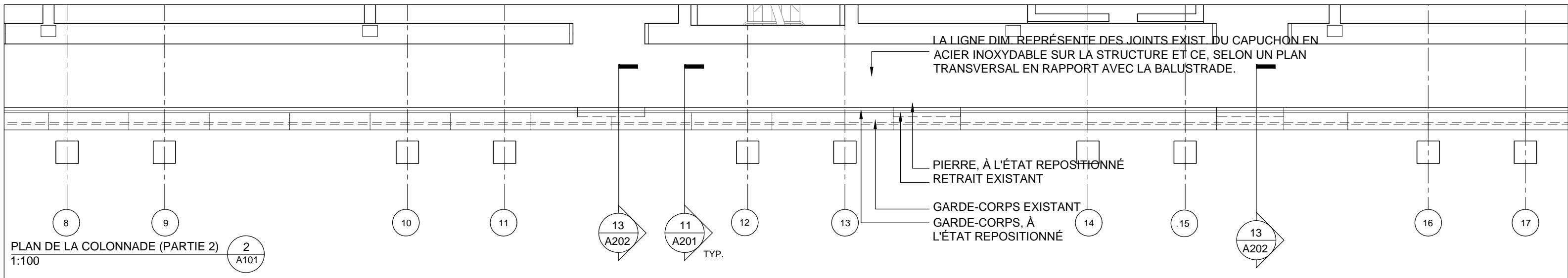
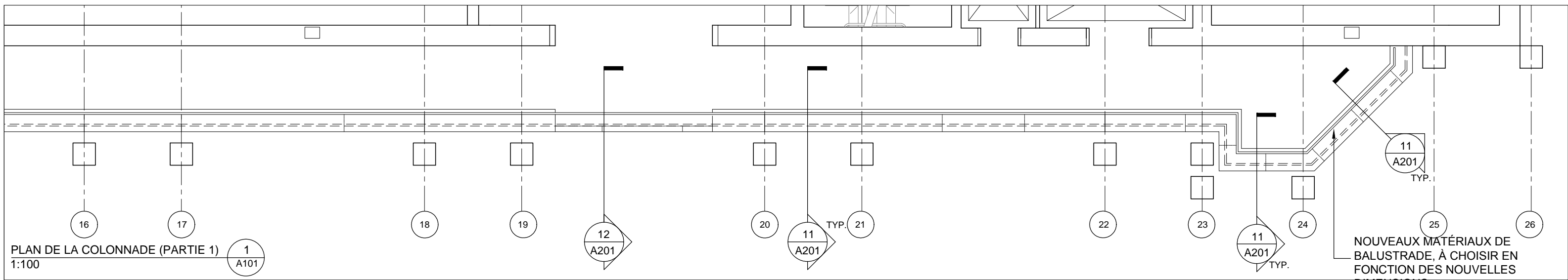

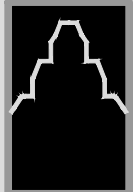
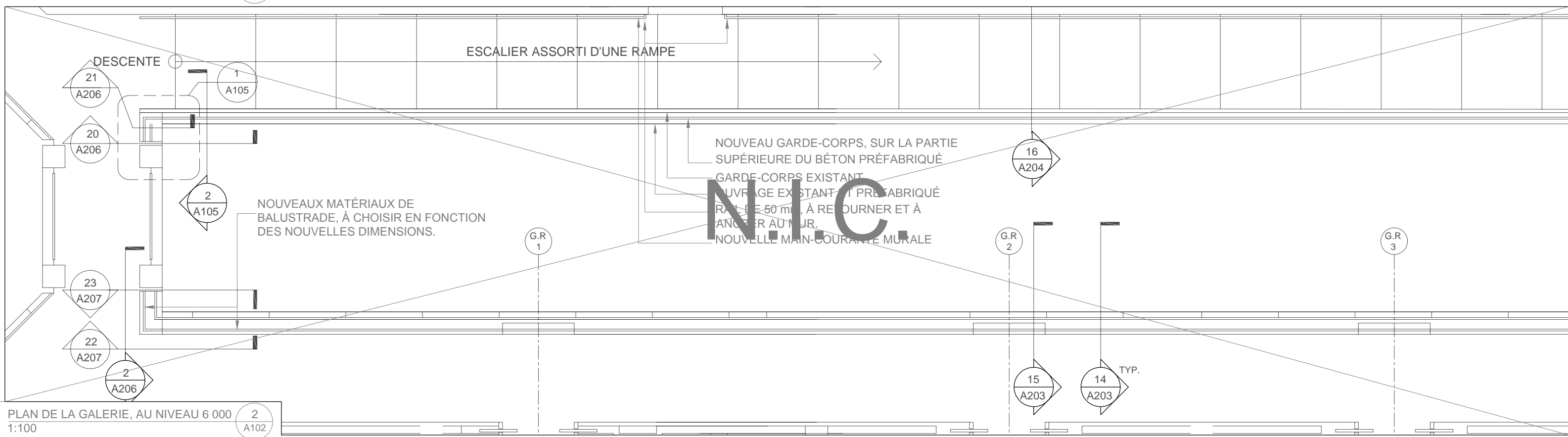
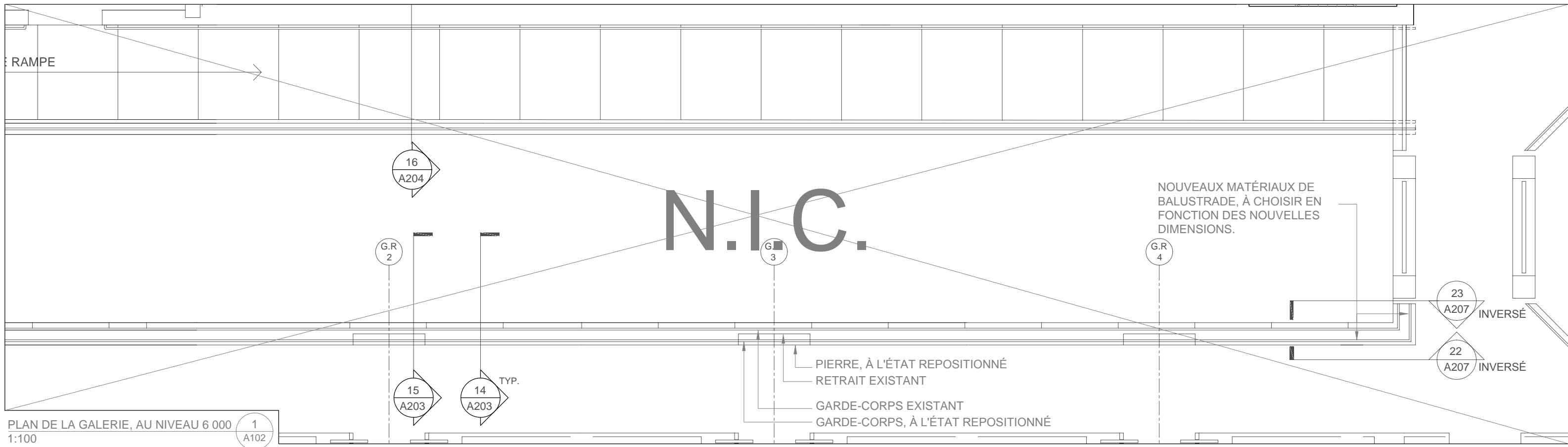

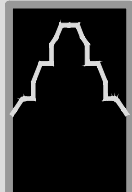
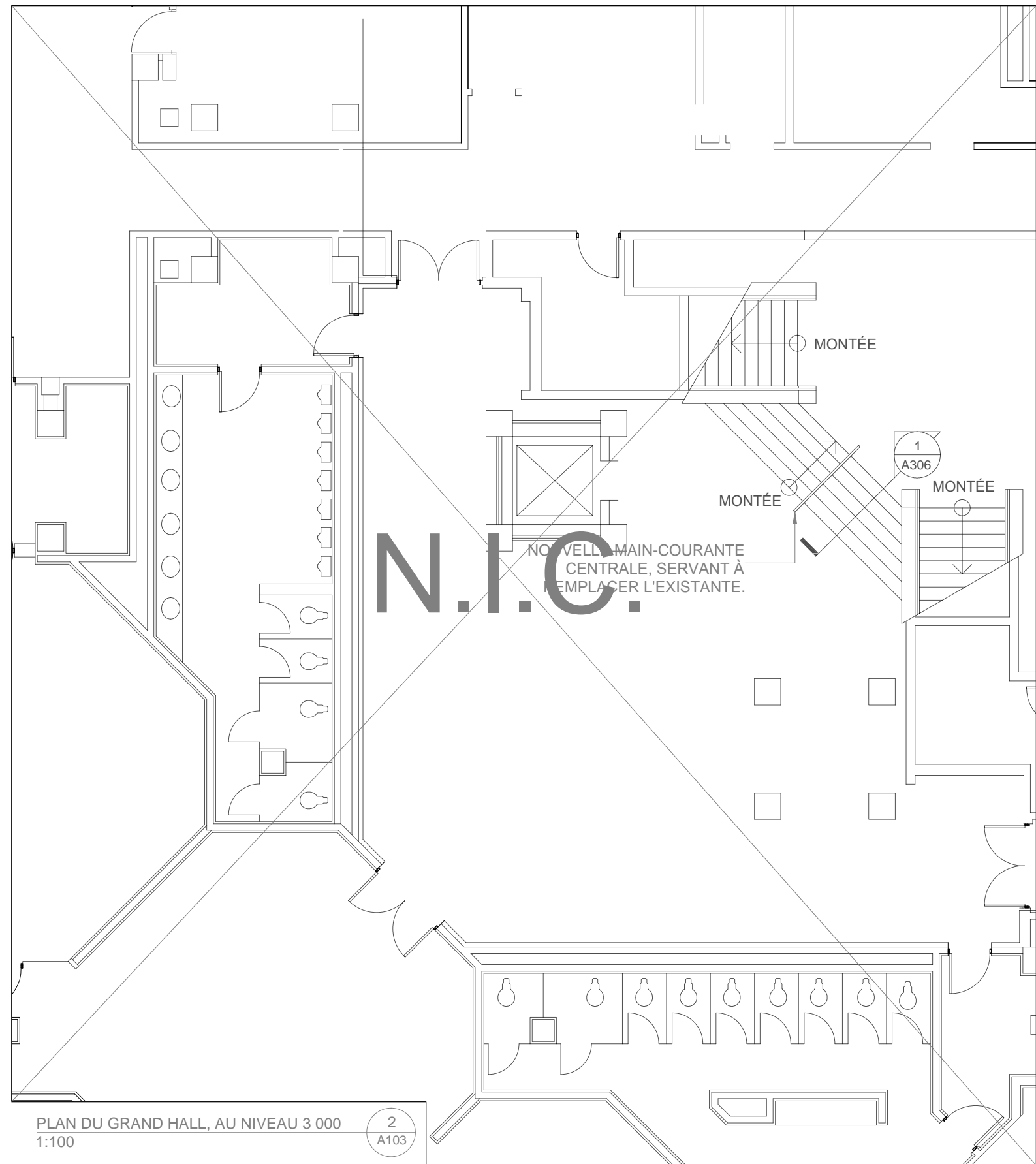
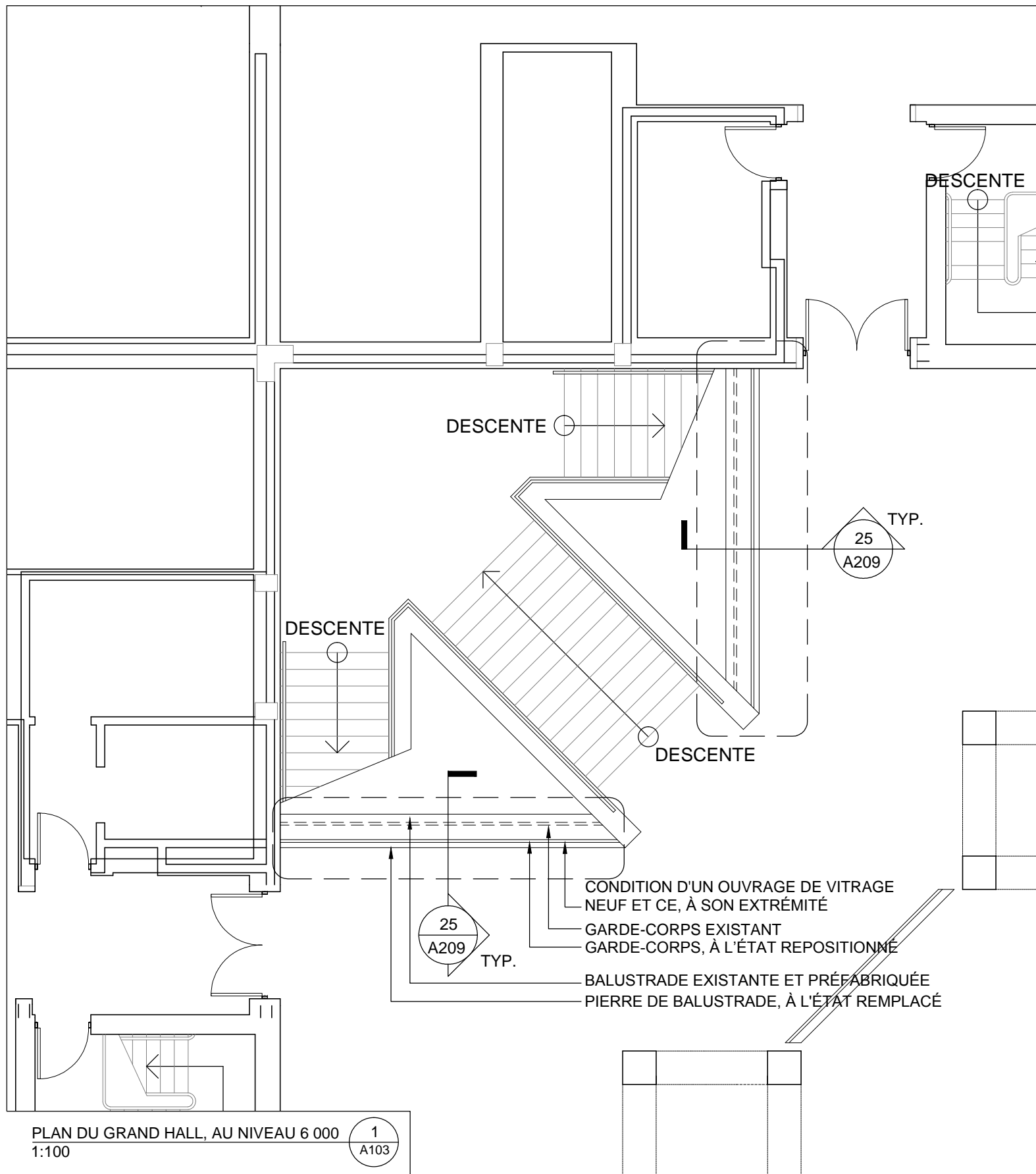

Musée des beaux arts du Canada

A104 - PLANS DU GRAND HALL

ÉCHELLE 1 : 100

Mises à jour du Code de construction – Phase II
A103

LE 15 FÉV. 2017

Moshe Safdie and Associates, Inc.

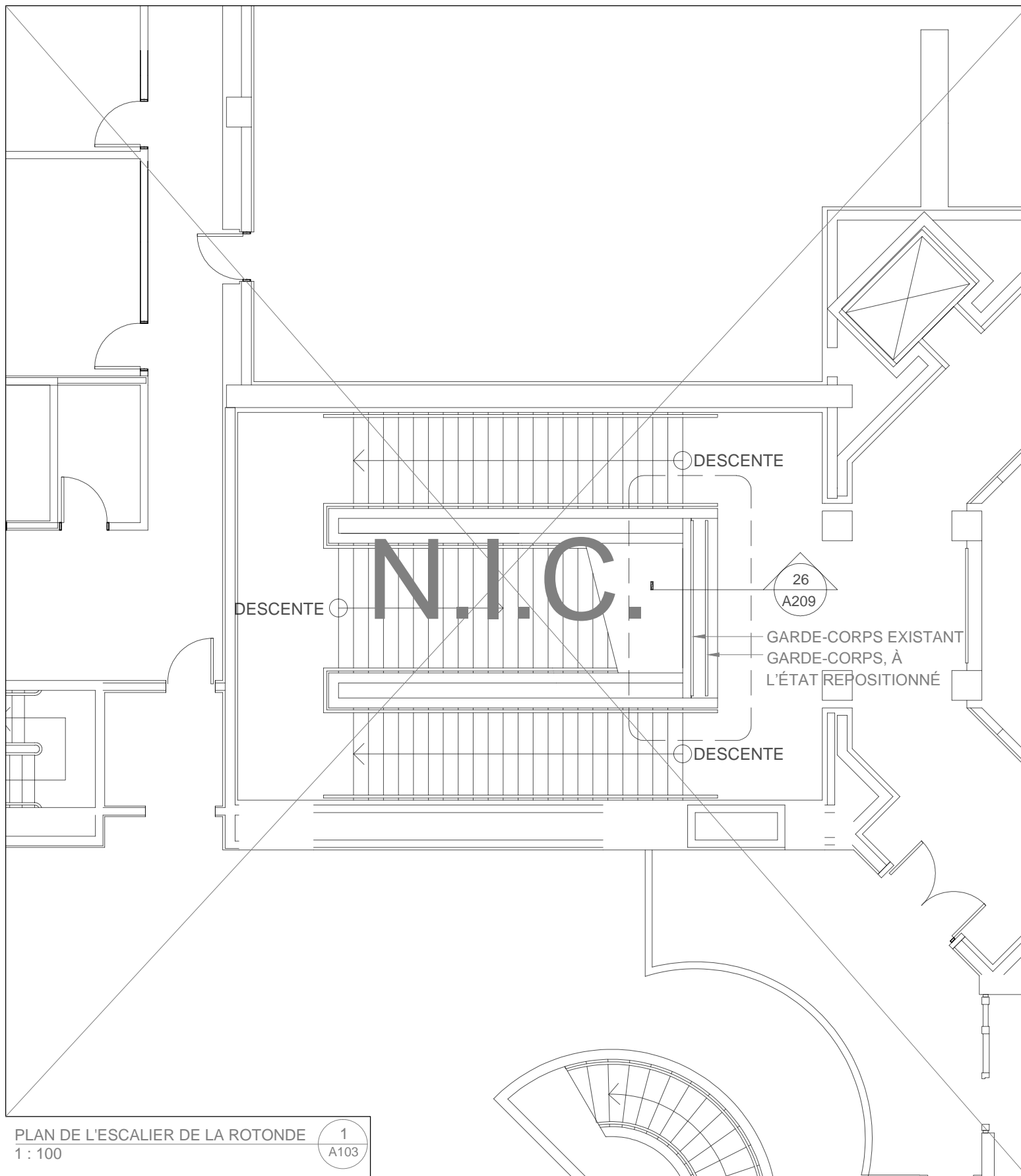

PLAN DE L'ESCALIER DE LA ROTONDE
1 : 100

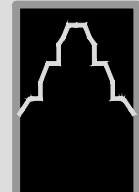

Musée des beaux arts du Canada

A103 - PLAN DE LA ROTONDE

ÉCHELLE 1 : 100

Mises à jour du Code de construction – Phase II
A104

LE 15 FÉV. 2017

Moshe Safdie and Associates, Inc.

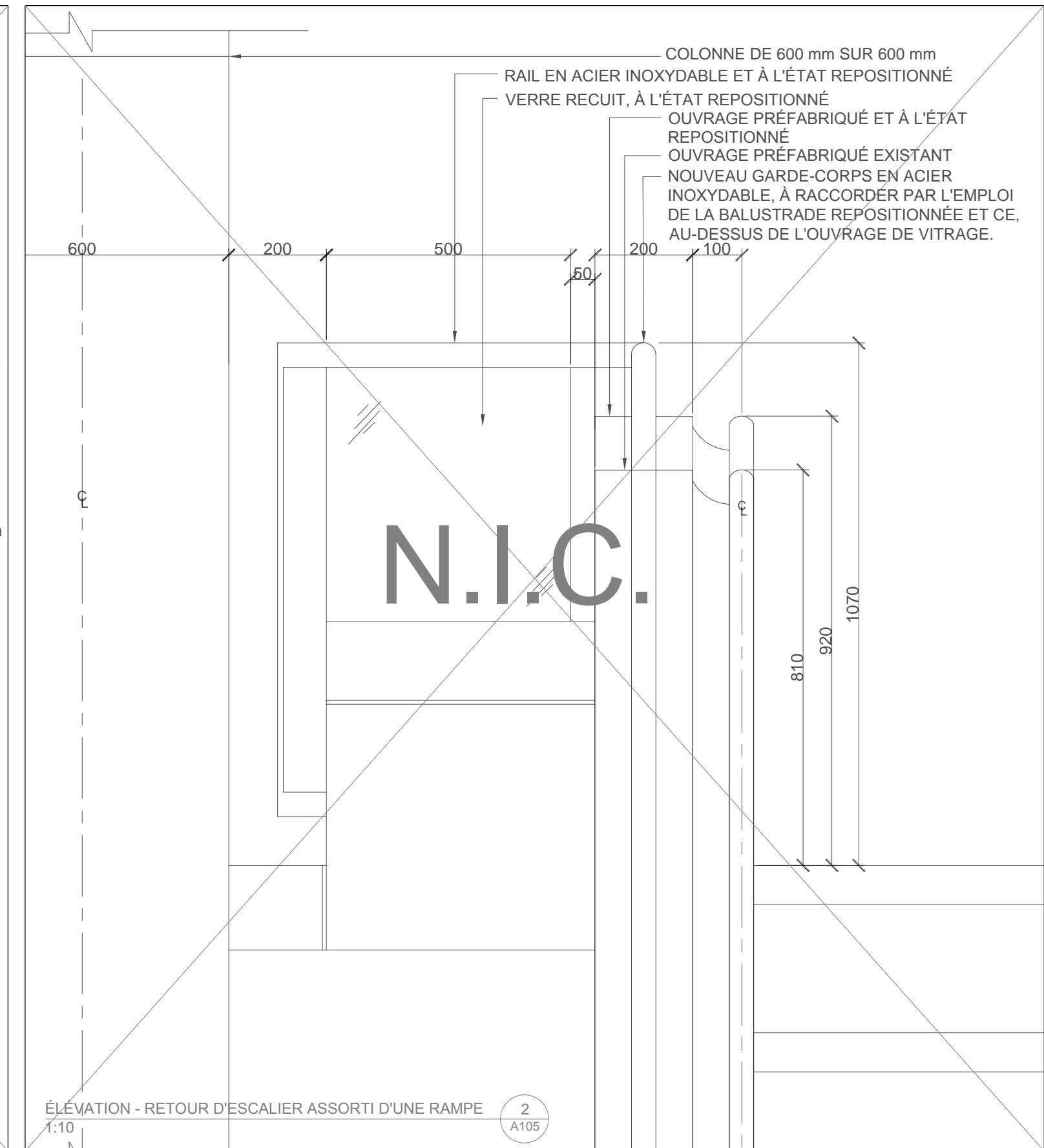
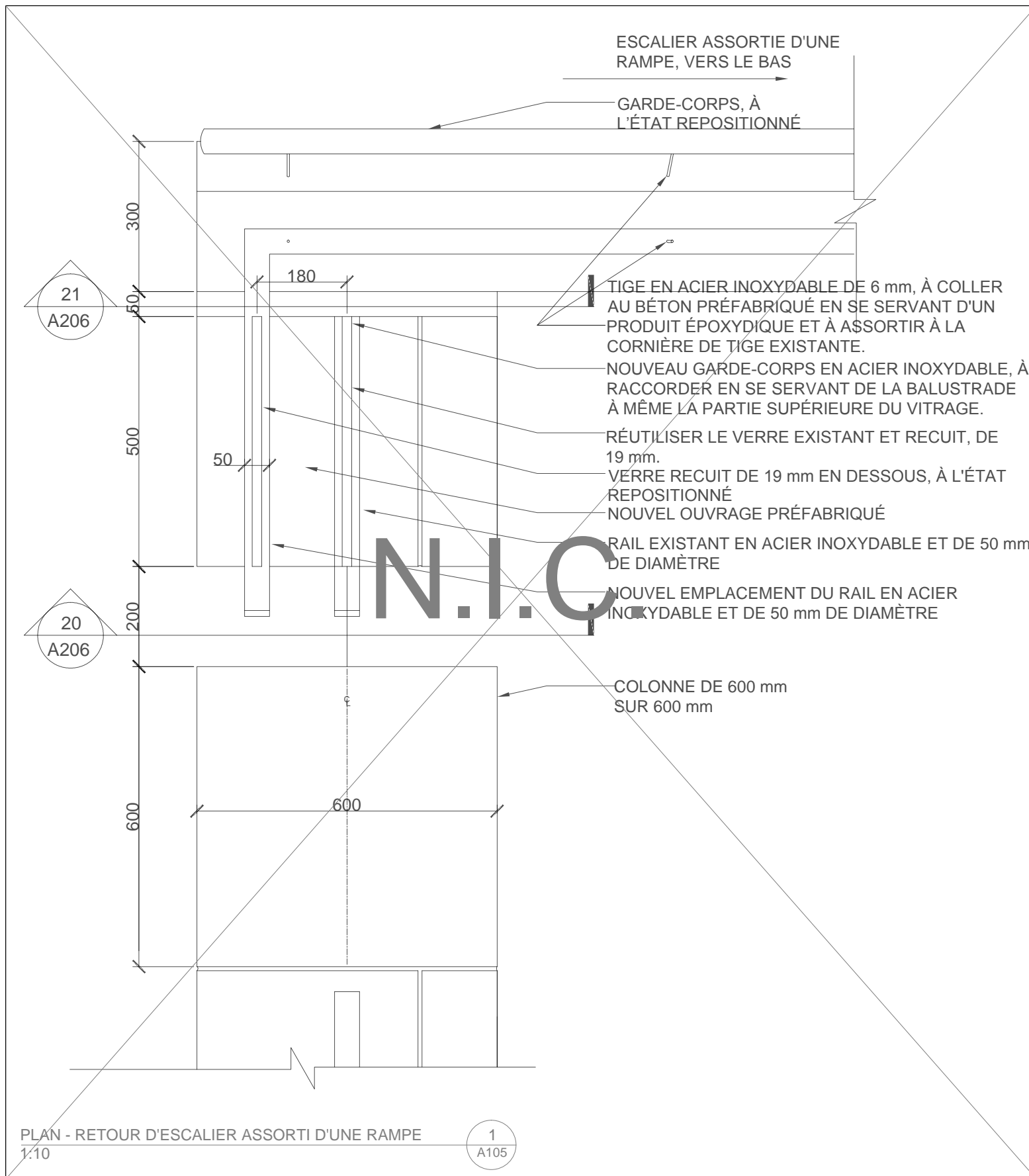

Musée des beaux arts du Canada

A105 - BALUSTRADE DE RETOUR D'ESCALIER
ASSORTI D'UNE RAMPE, AU NIVEAU 6 000
ÉCHELLE 1:10

Mises à jour du Code de construction – Phase II
A105

LE 15 FÉV. 2017

Moshe Safdie and Associates, Inc.

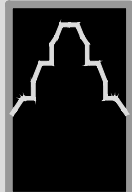
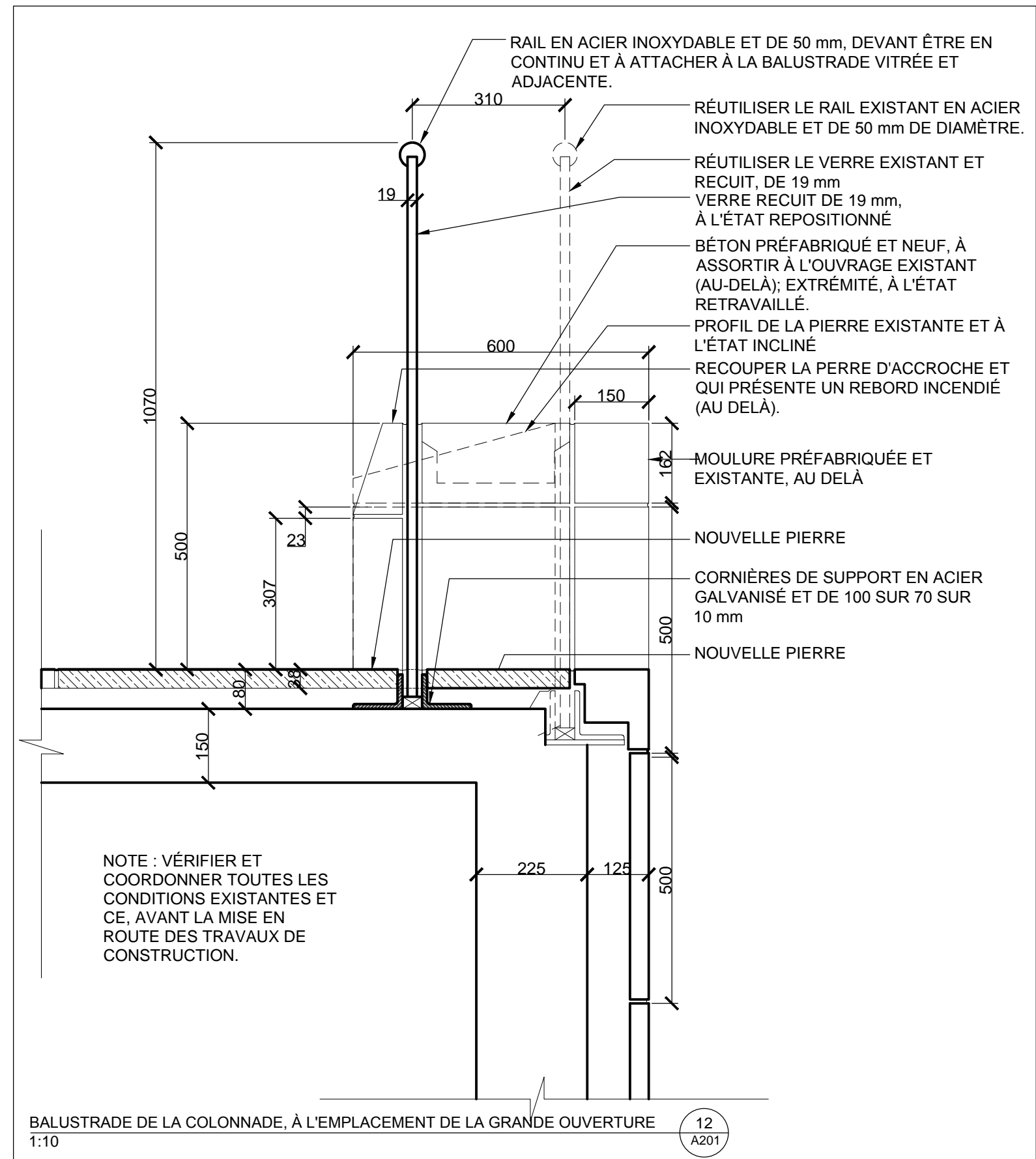
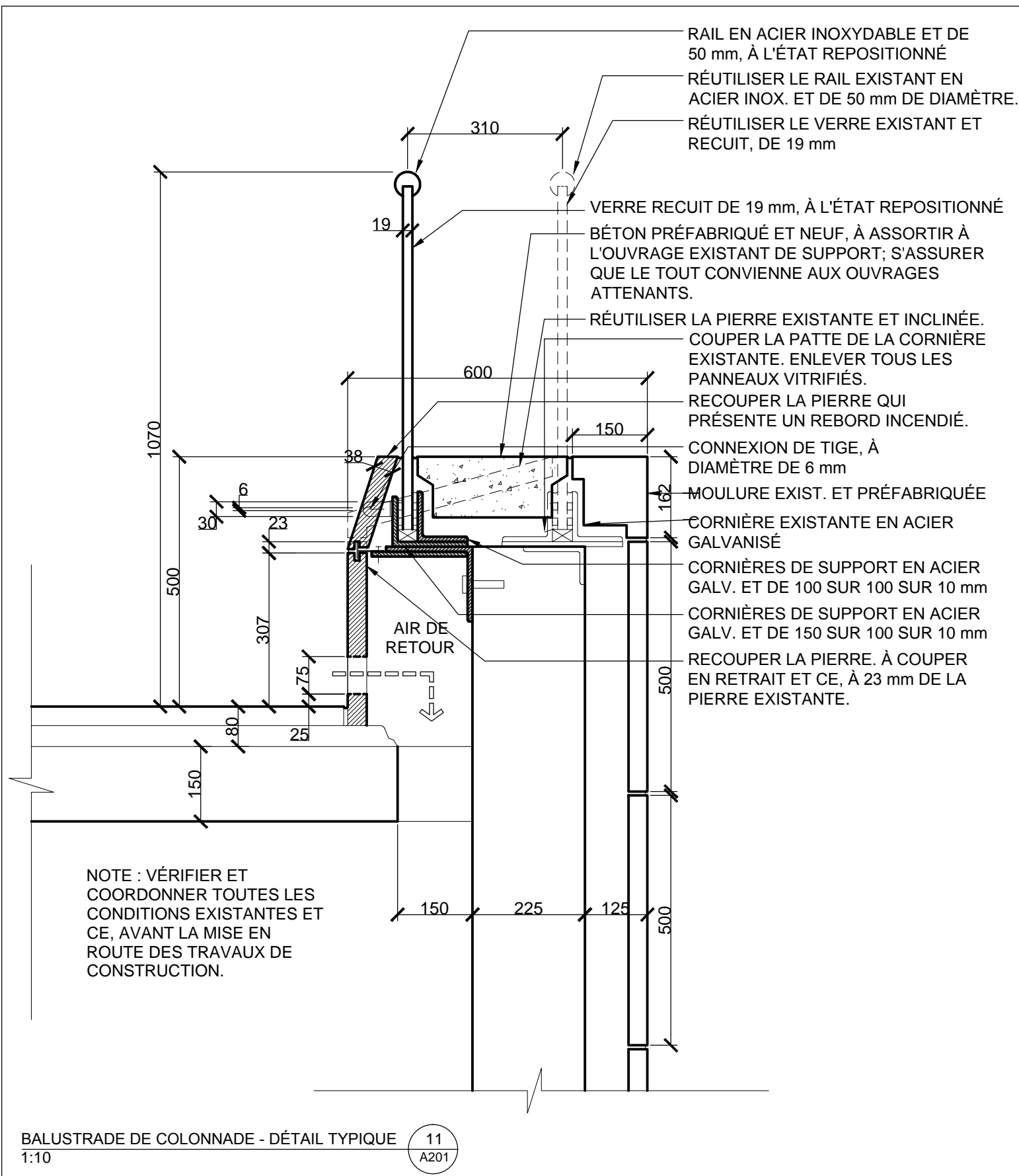

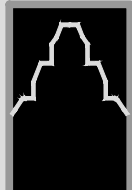
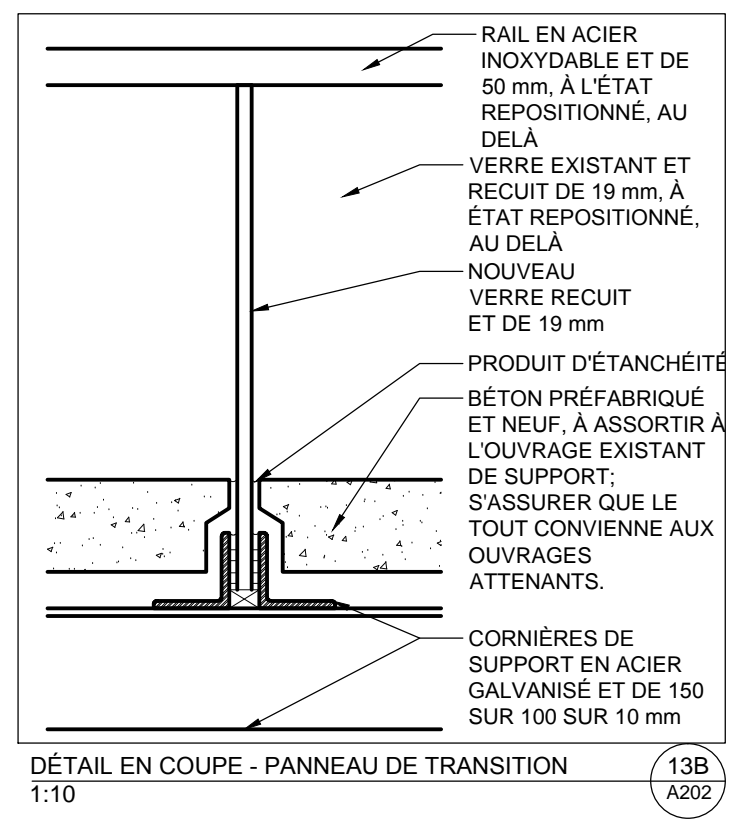
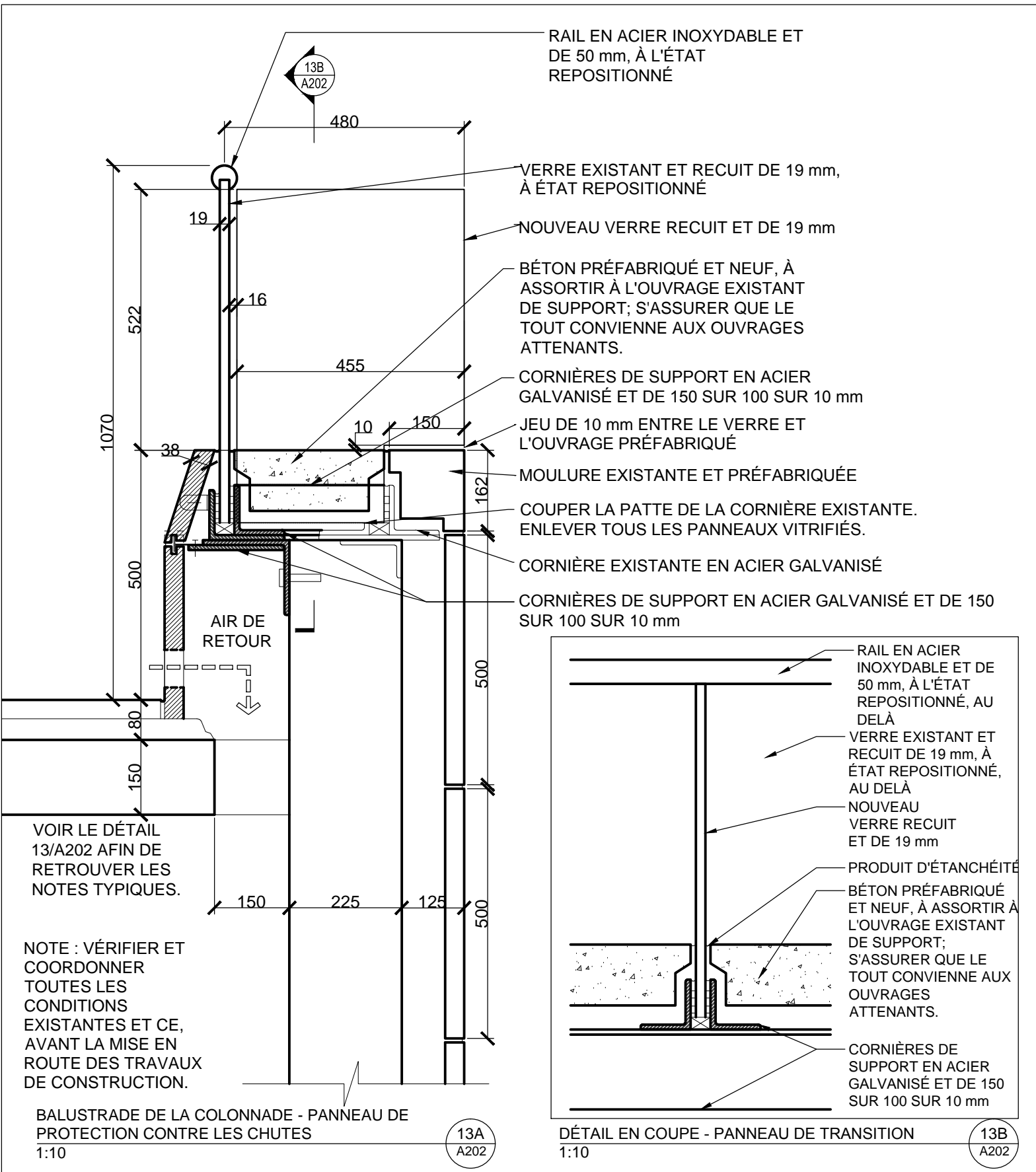
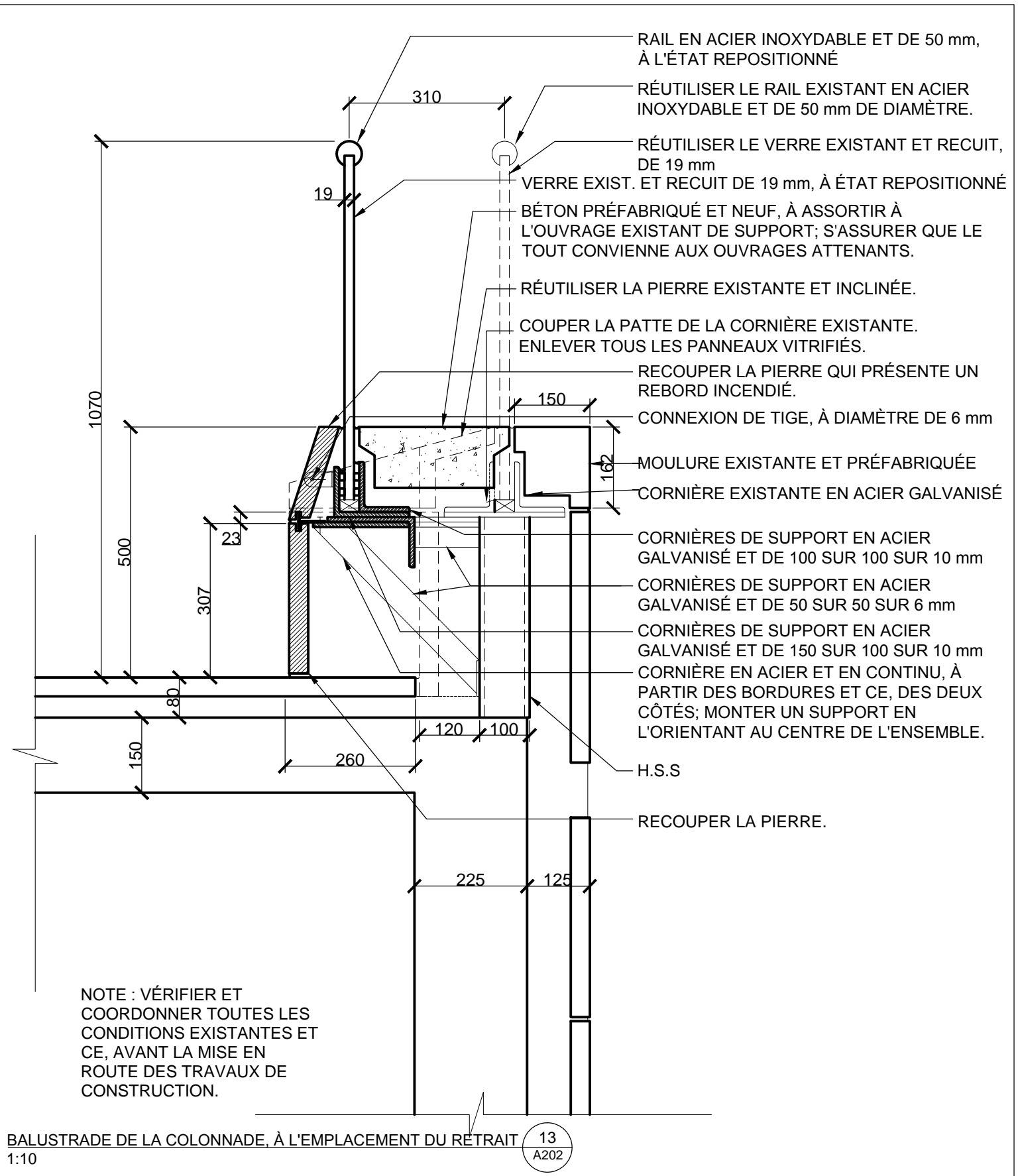

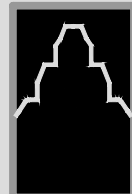
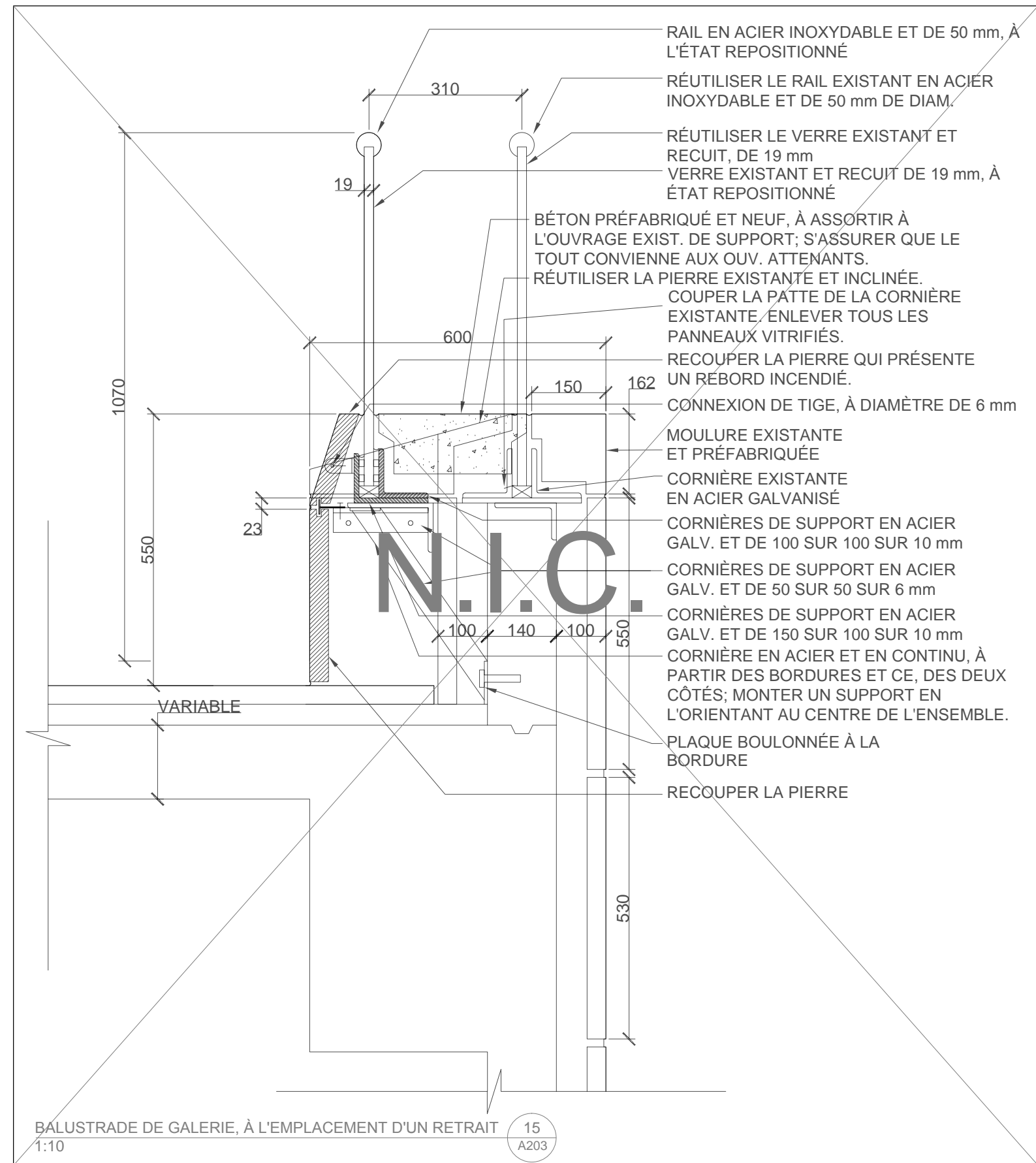
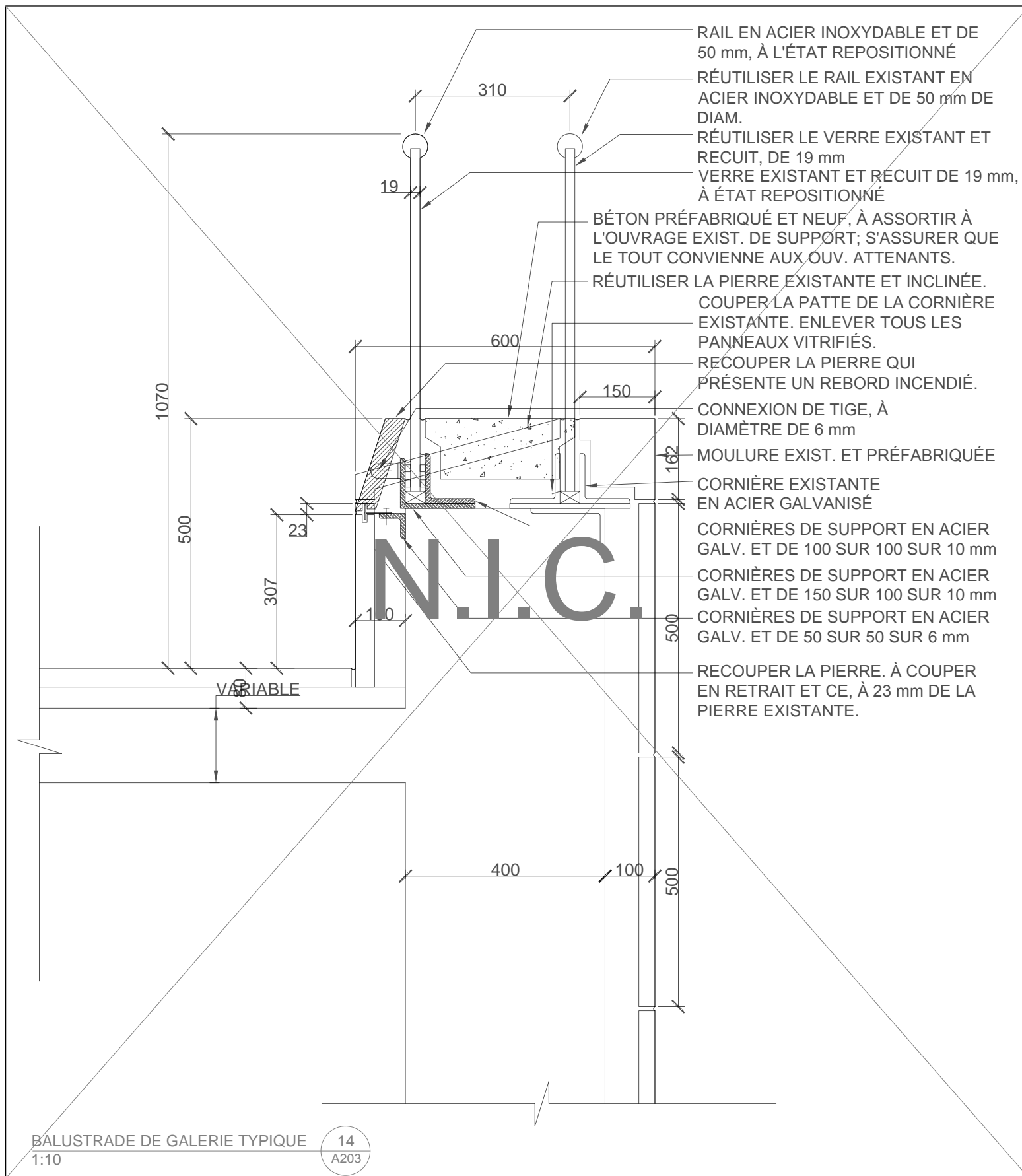

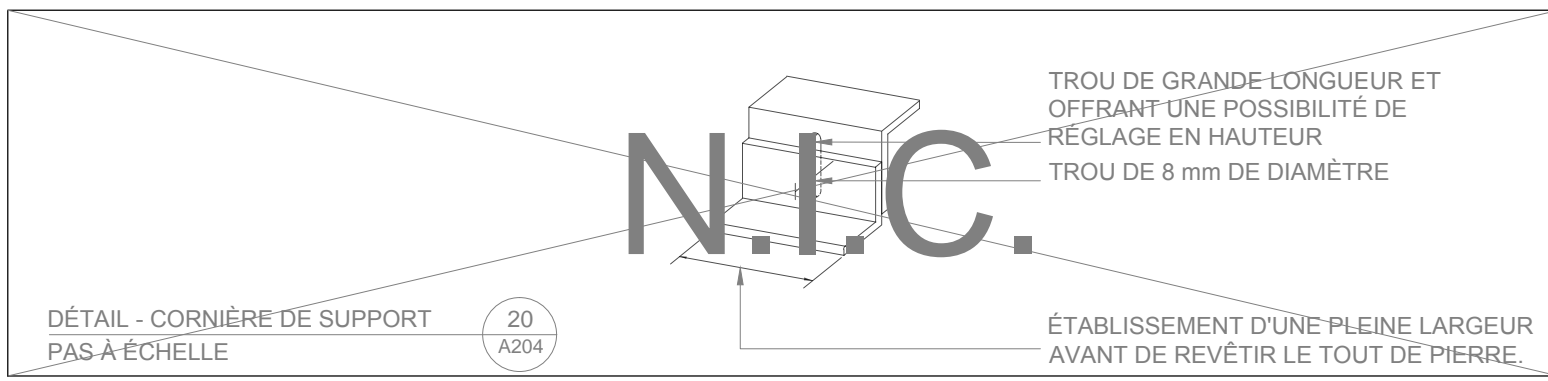
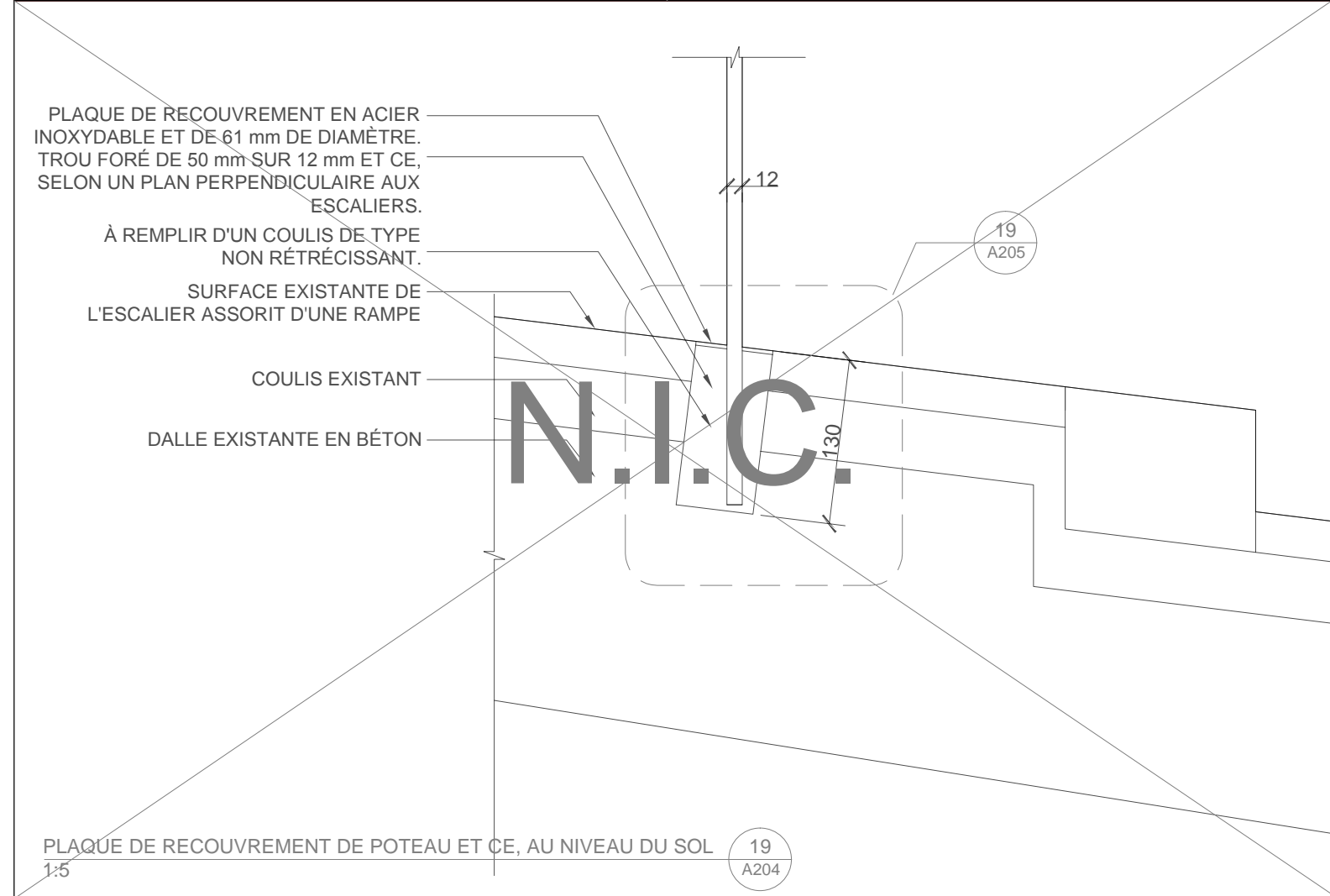
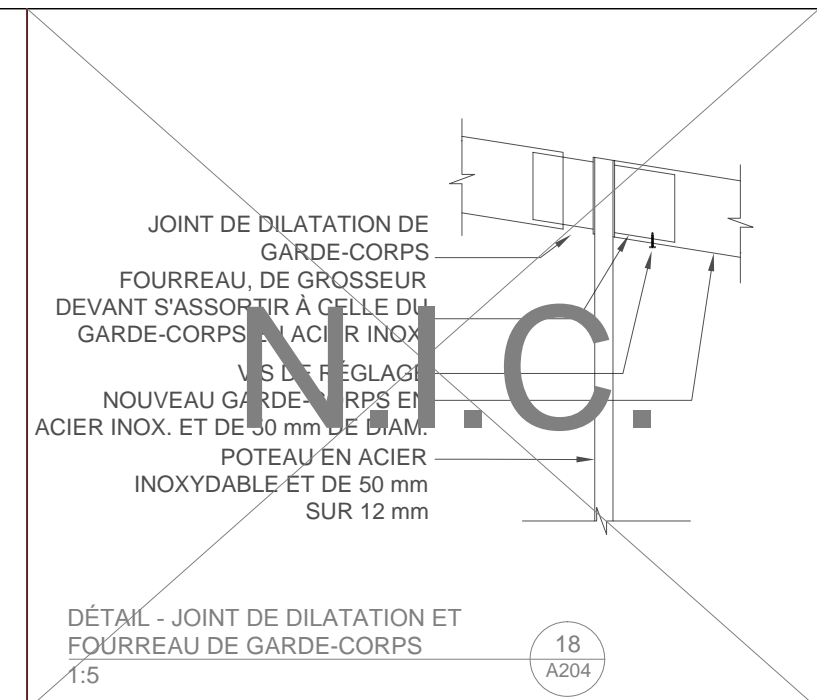
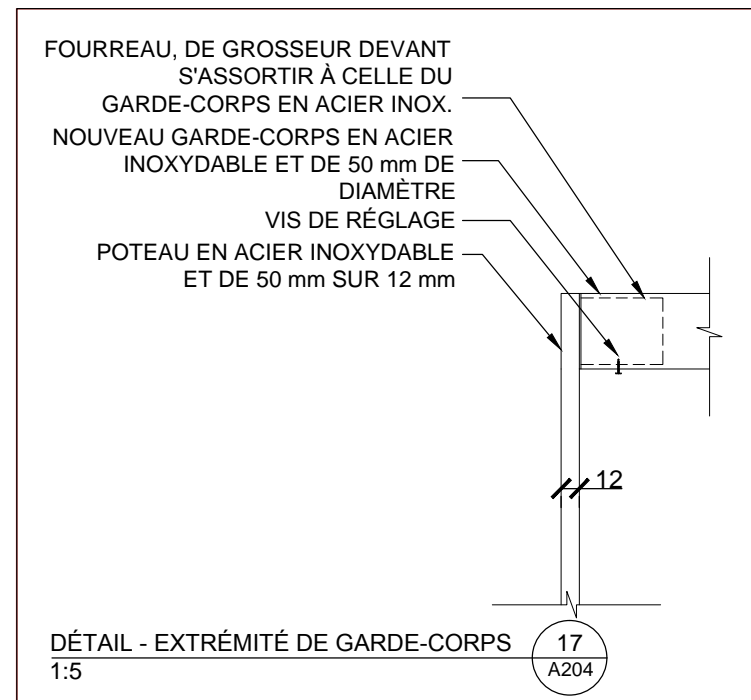
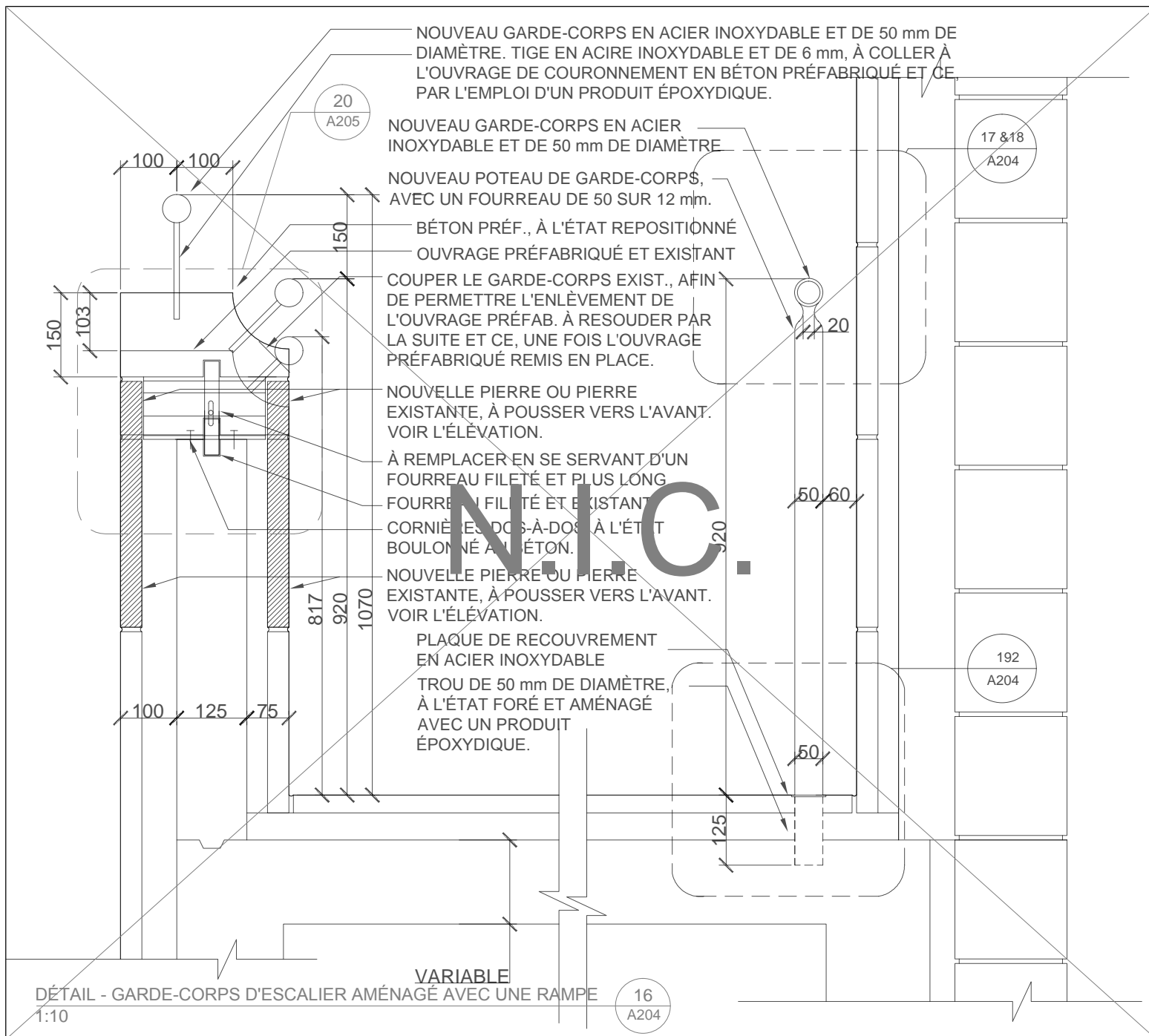

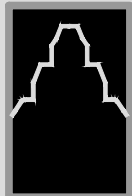
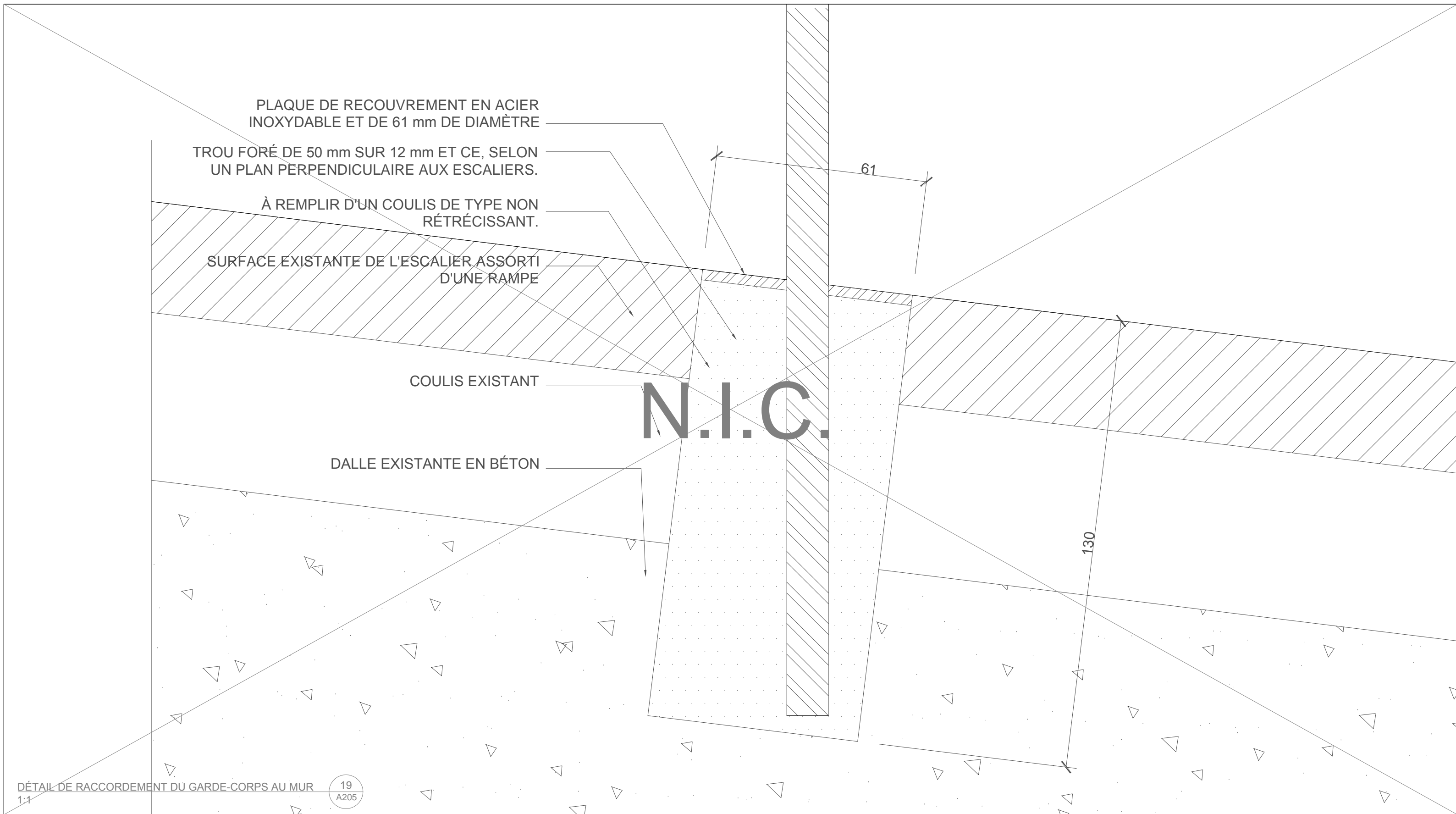

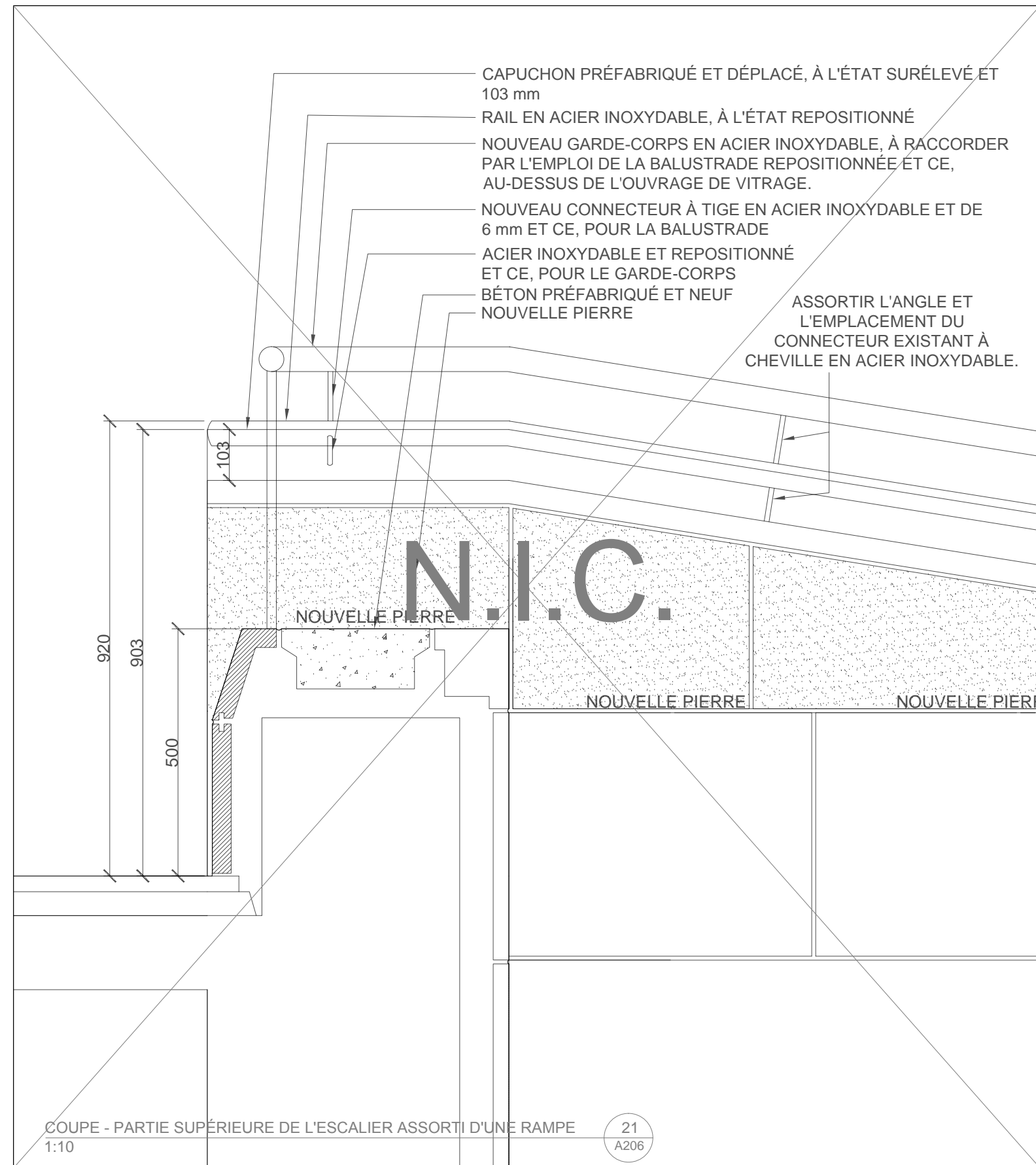
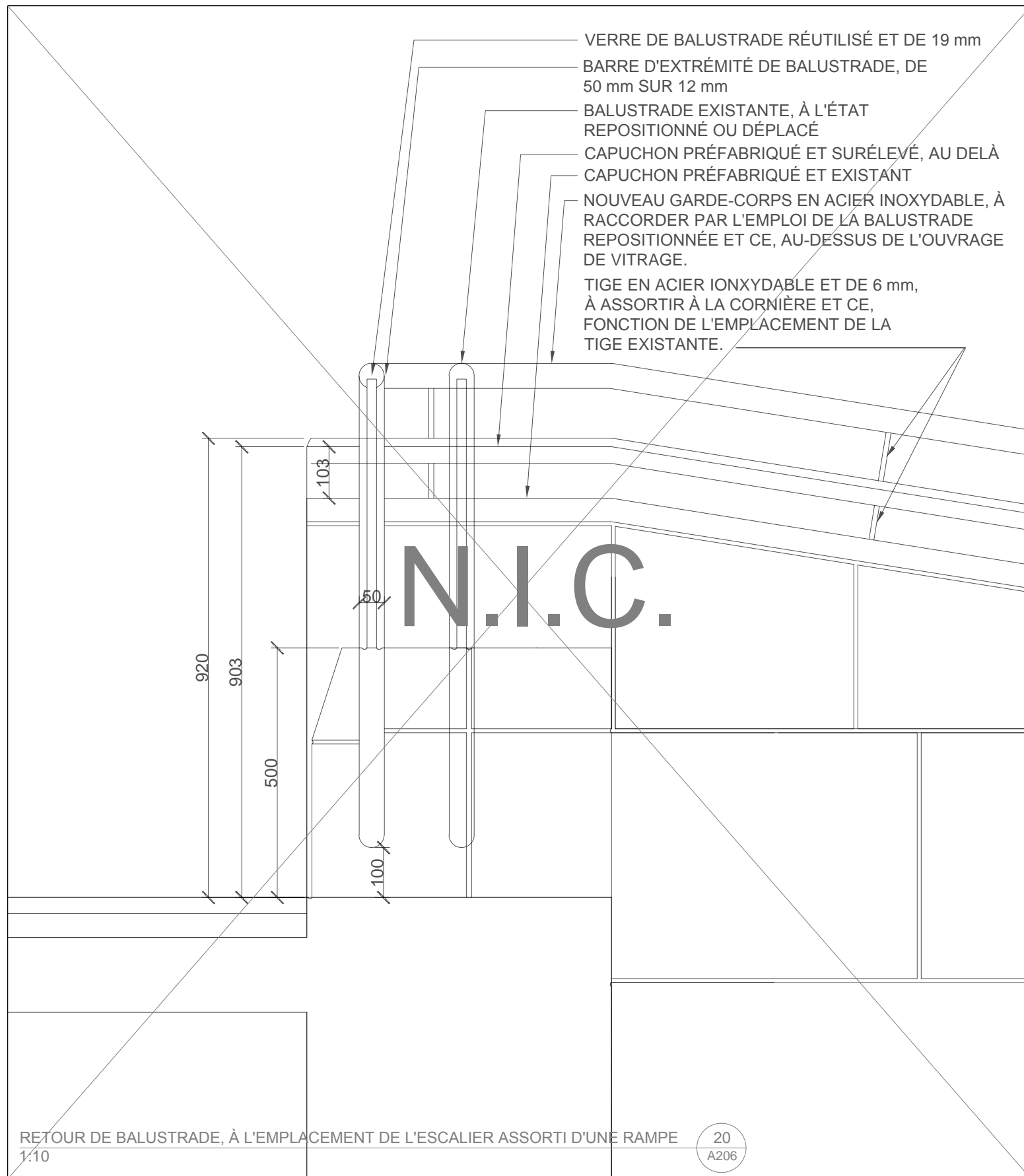

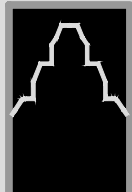
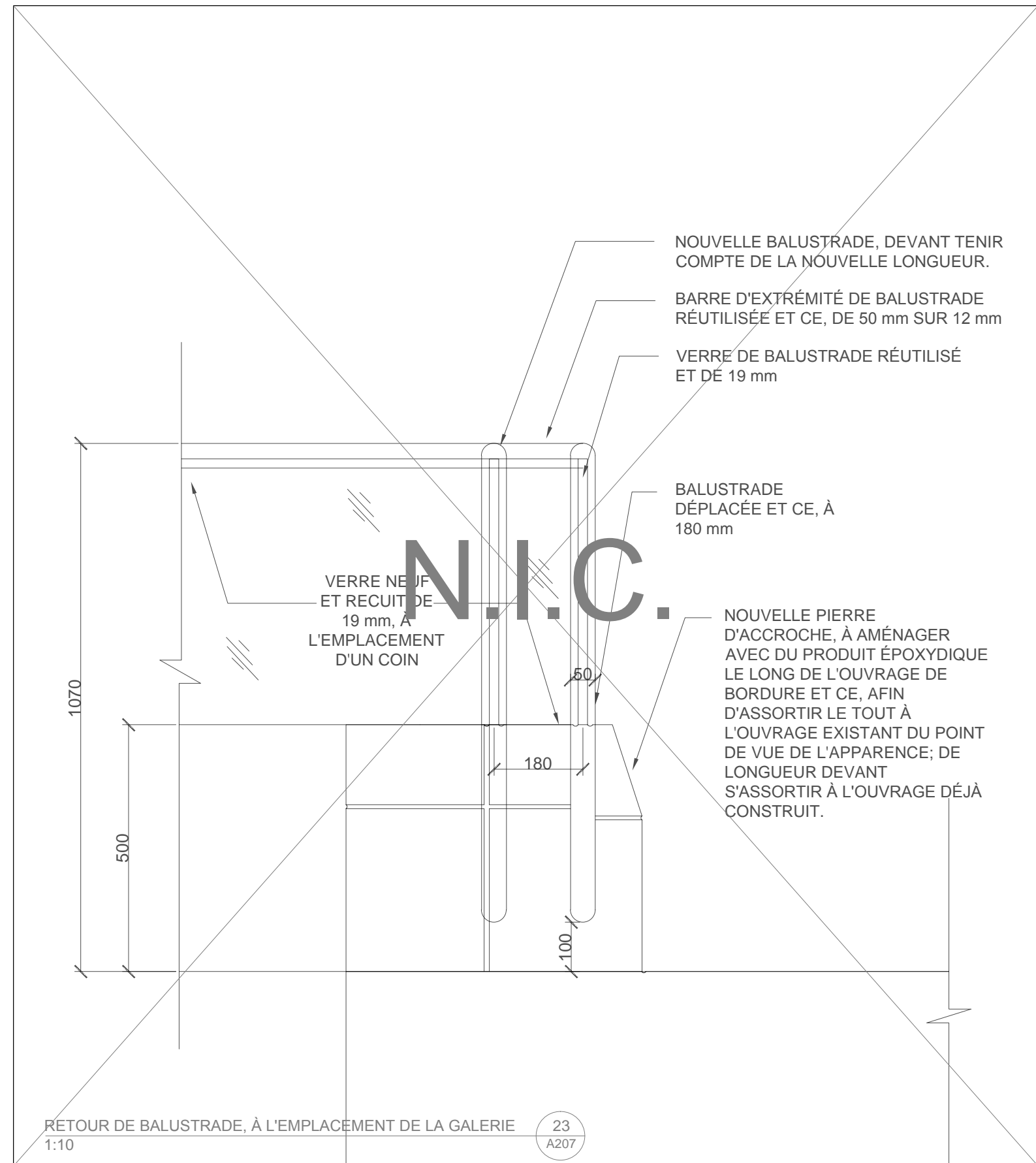
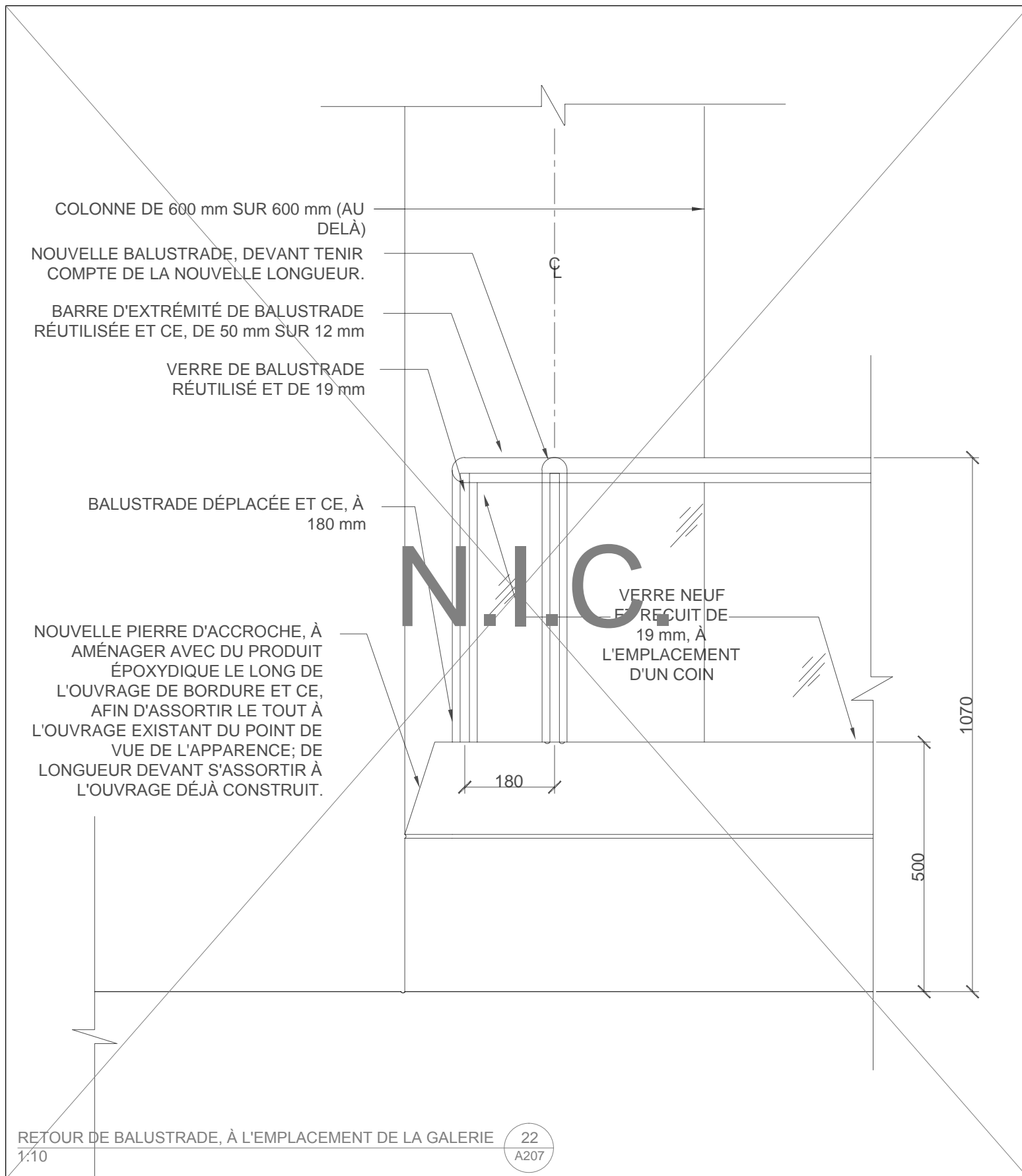

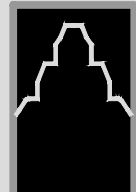
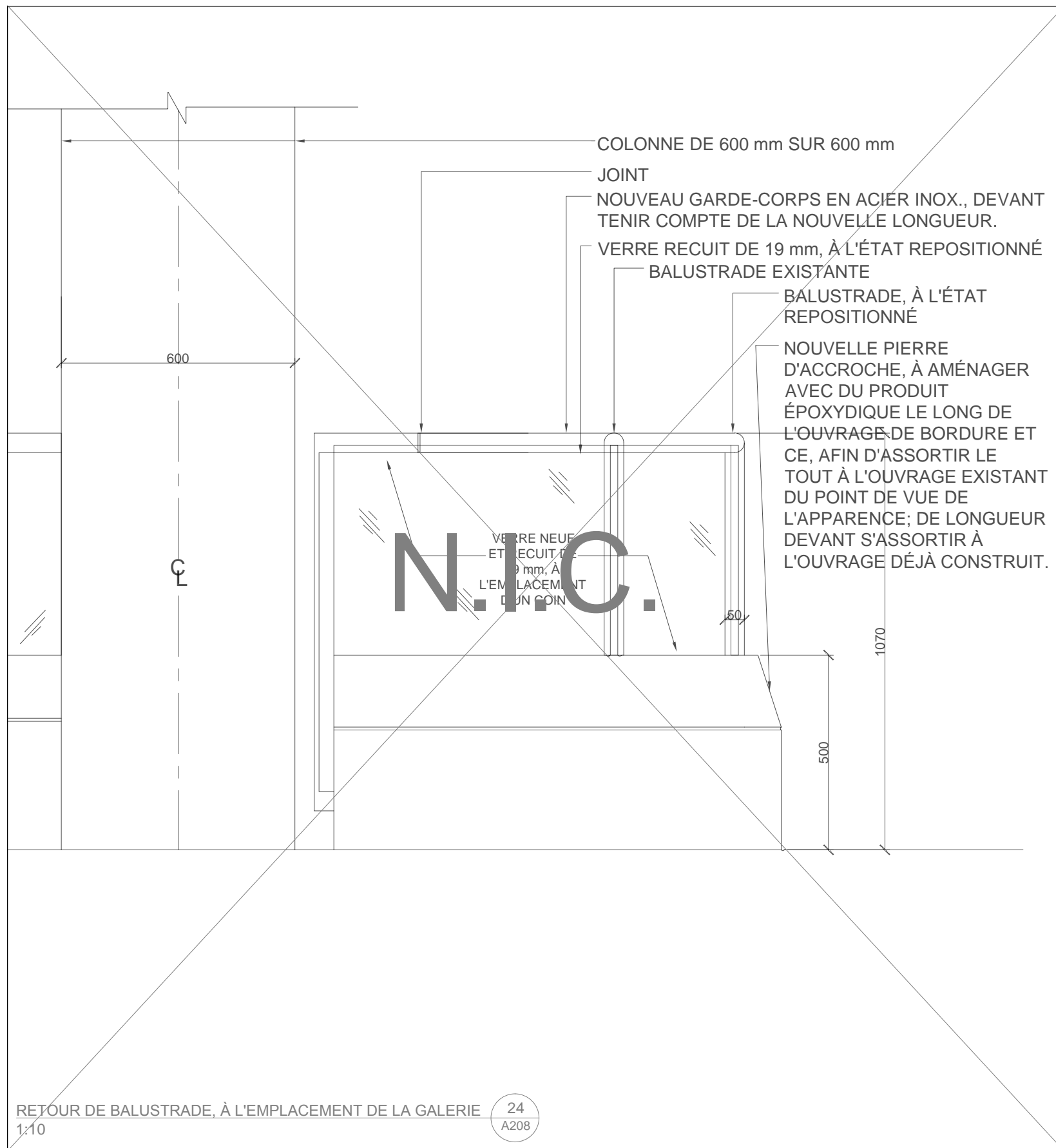

Musée des beaux arts du Canada

A208 - DÉTAIL - ÉLÉVATION - RETOUR DE BALUSTRADE

ÉCHELLE 1 : 100

Mises à jour du Code de construction – Phase II
A208

LE 15 FÉV. 2017

Moshe Safdie and Associates, Inc.

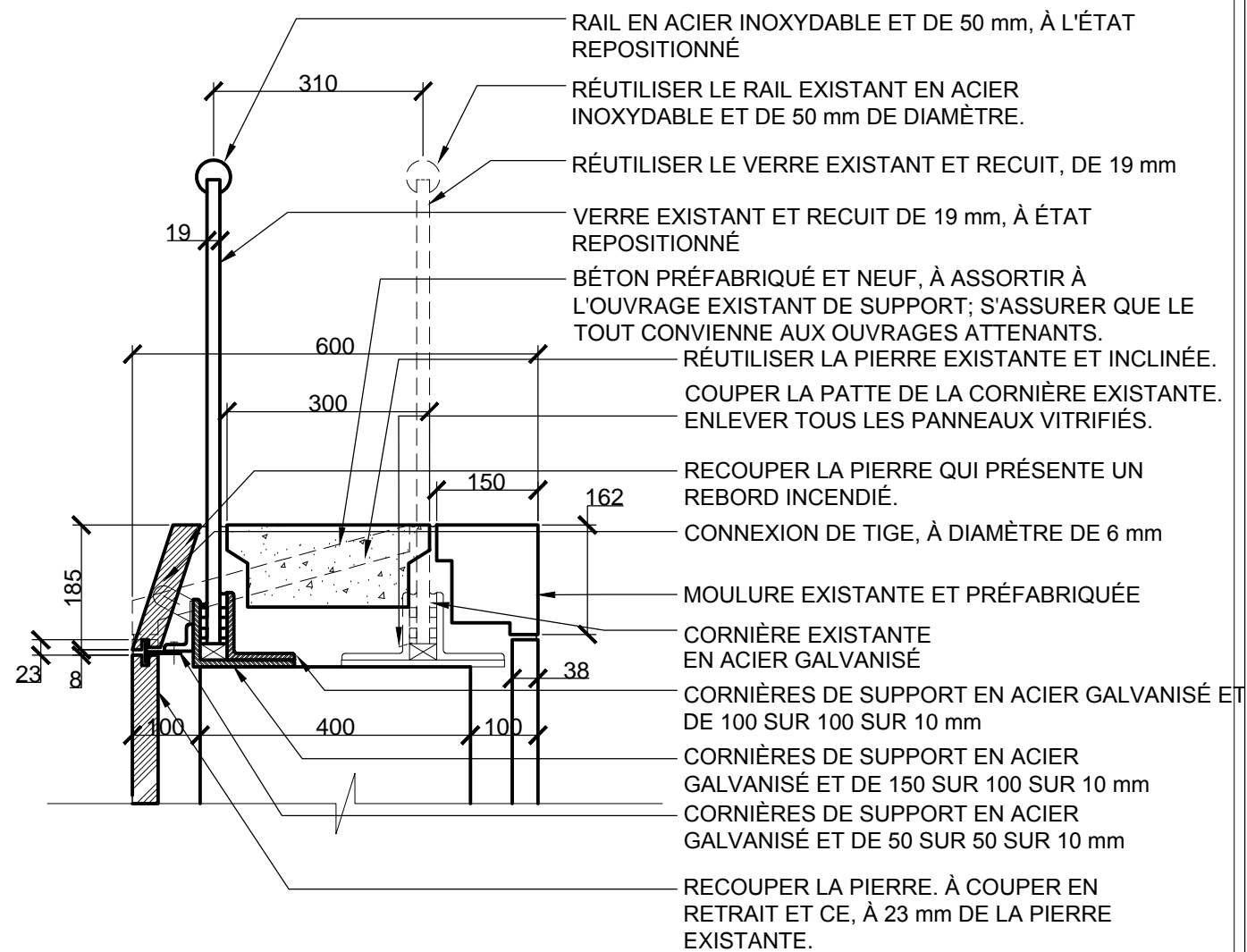

BALUSTRADE DU GRAND HALL
1:10

25
A209

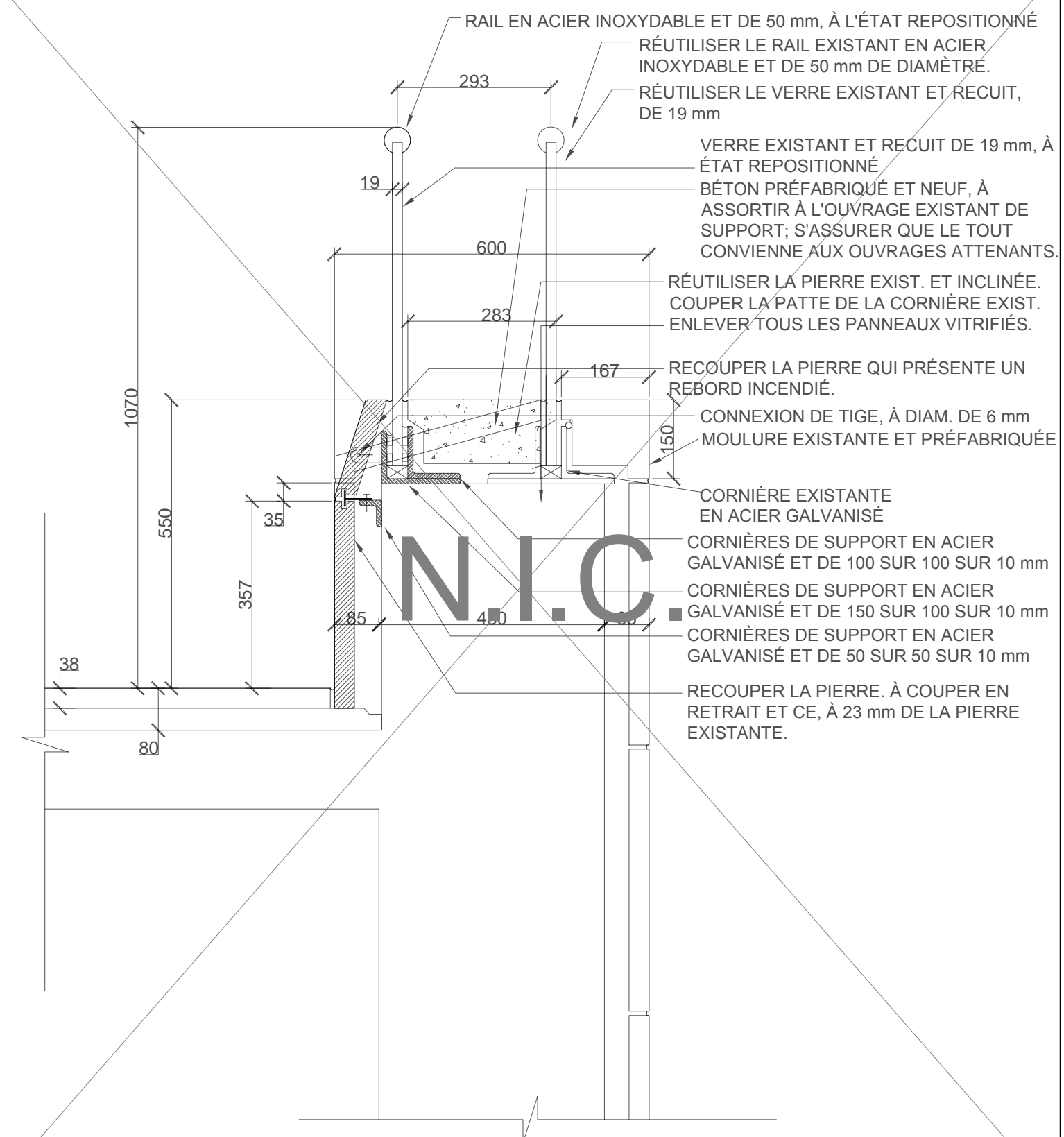

DÉTAIL TYPIQUE - BALUSTRADE DE ROTONDE
1:10

26
A209



Musée des beaux arts du Canada

A209 - DÉTAIL - BALUSTRADE D'ESCALIER DE LA ROTONDE ET (OU) DU GRAND HALL
ÉCHELLE 1 : 100

Mises à jour du Code de construction – Phase II
A209

LE 15 FÉV. 2017
Moshe Safdie and Associates, Inc.

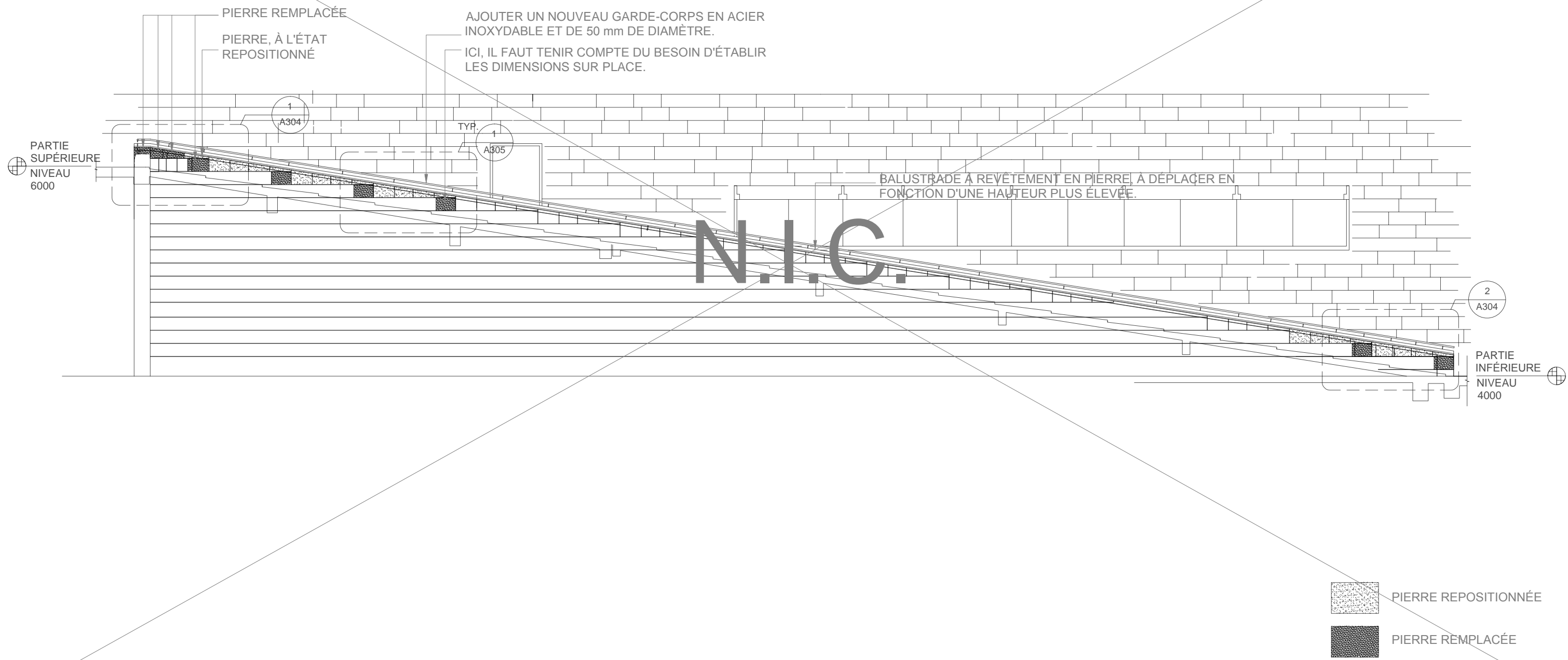

N.I.C.

ÉLÉVATION - ESCALIER ASSORTI D'UNE RAMPE 1 A301
1:150

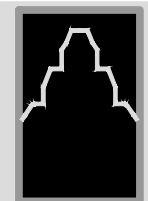

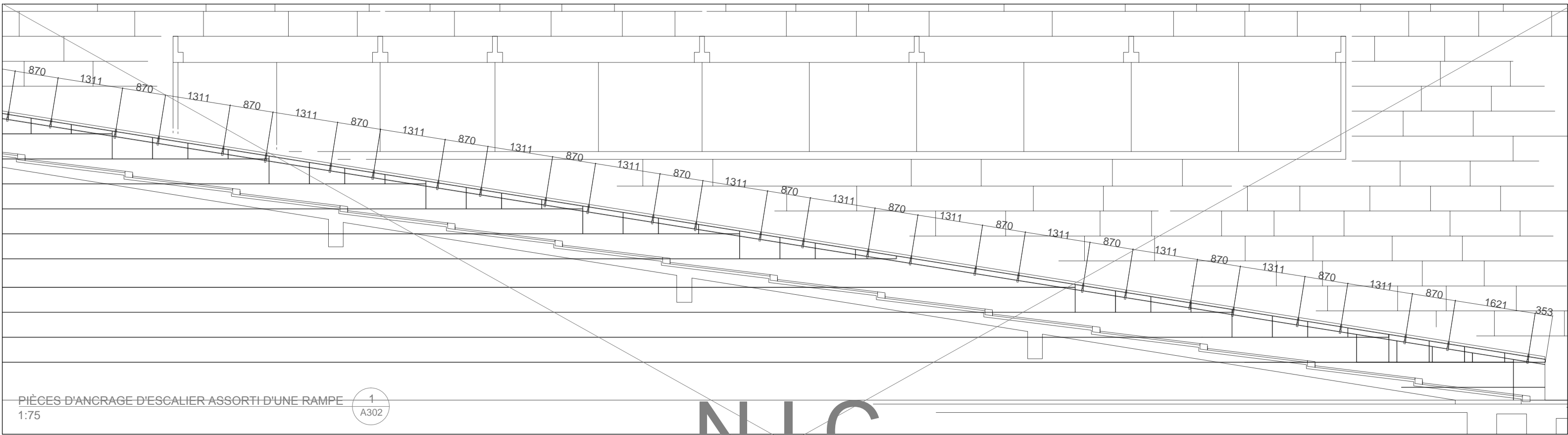

PIÈCES D'ANCRAGE D'ESCALIER ASSORTI D'UNE RAMPE
1:75

1
A302

N.I.C.

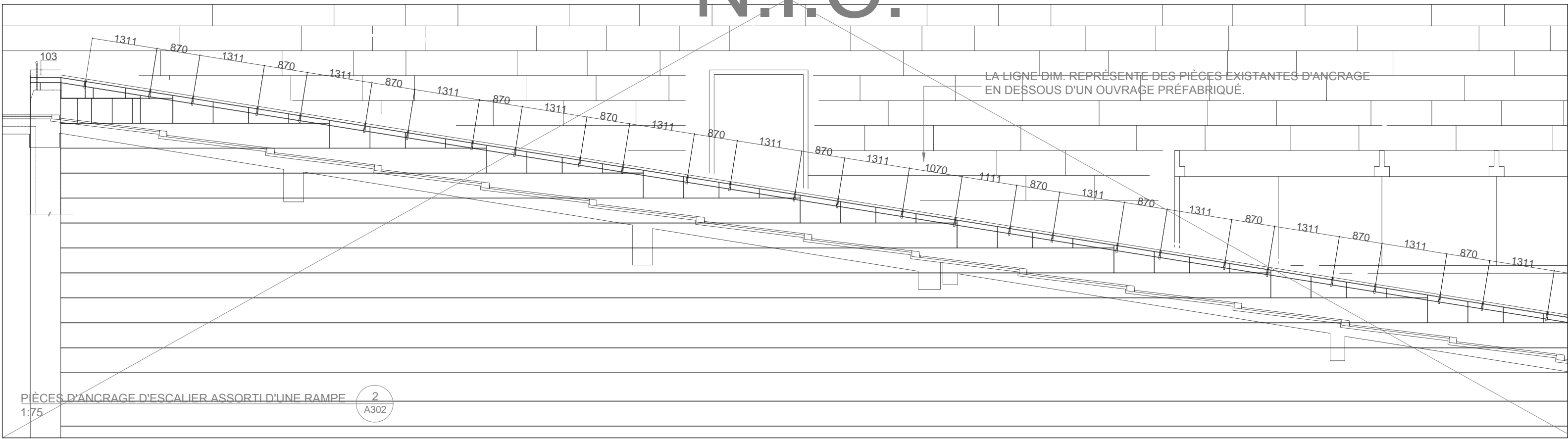

LA LIGNE DIM. REPRÉSENTE DES PIÈCES EXISTANTES D'ANCRAGE
EN DESSOUS D'UN OUVRAGE PRÉFABRIQUÉ.

PIÈCES D'ANCRAGE D'ESCALIER ASSORTI D'UNE RAMPE
1:75

2
A302



PARTIE SUPÉRIEURE
NIVEAU 6000

920

1666, 1500, 1308, 1500, 1500, 1308, 1500

JOINT DE DILATATION LE LONG DU RAIL
JOINT DE DILATATION LE LONG DE L'ESCALIER
JOINT DE DILATATION SUR UNE DALLE

2
A303
N.I.C.

RAIL EN TUBULURE DE 50 mm DE DIAMÈTRE, À
RETOURNER ET À ANCRER AU MUR.

LA LIGNE DIM. REPRÉSENTE LA DISTANCE
ENTRE LES LIGNES MÉDIANES DE POTEAUX.

PARTIE INFÉRIEURE
NIVEAU 4000

1308, 1500, 1359

ESCALIER ASSORTI D'UNE RAMPE - COUPE
1:150

1
A303



Musée des beaux arts du Canada

A303 - COUPE - GARDE-CORPS MURAL D'UN
ESCALIER ASSORTI D'UNE RAMPE
ÉCHELLE 1:150

Mises à jour du Code de construction – Phase II
A303

LE 15 FÉV. 2017
Moshe Safdie and Associates, Inc.

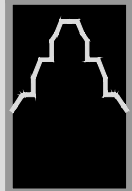
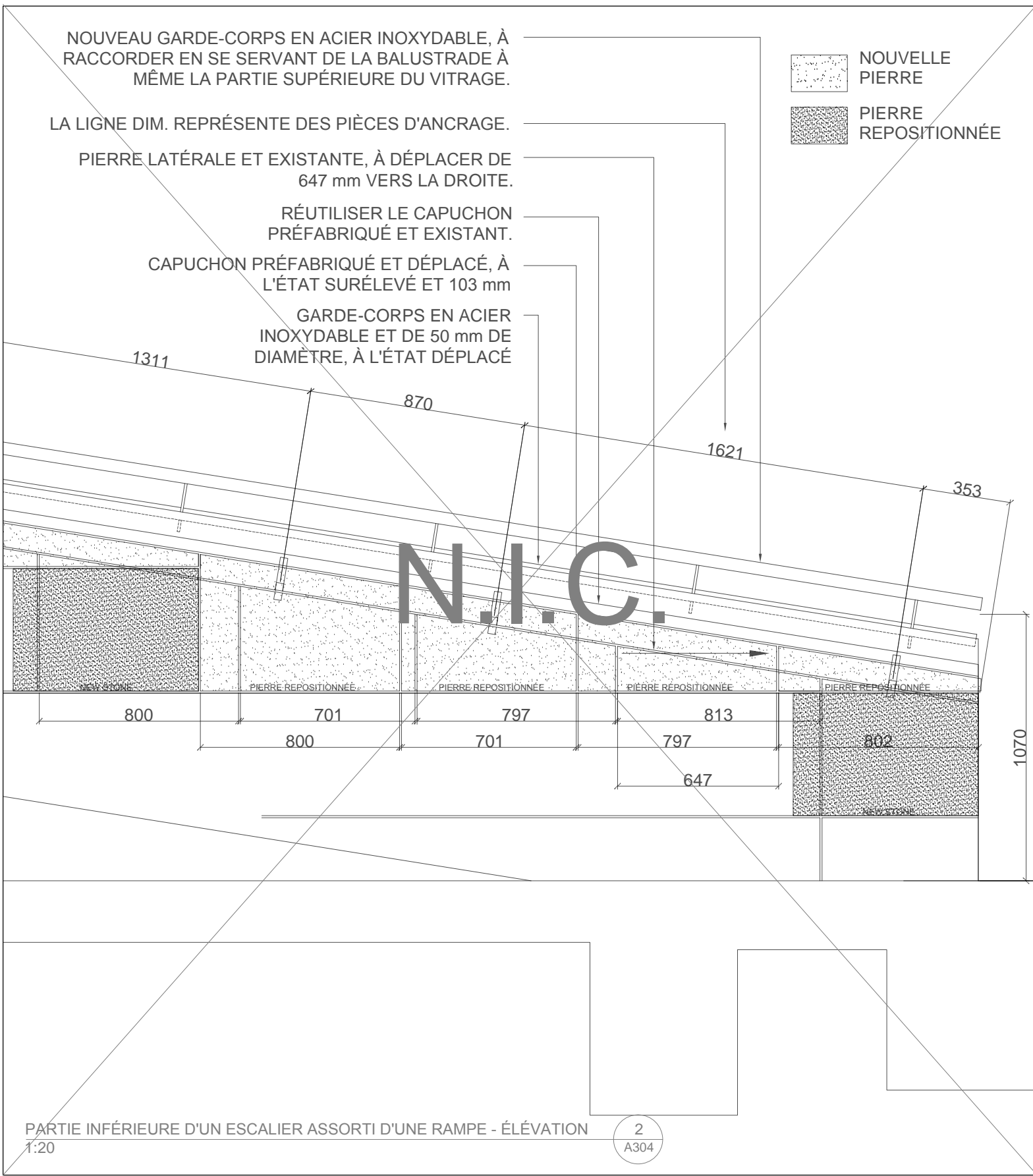
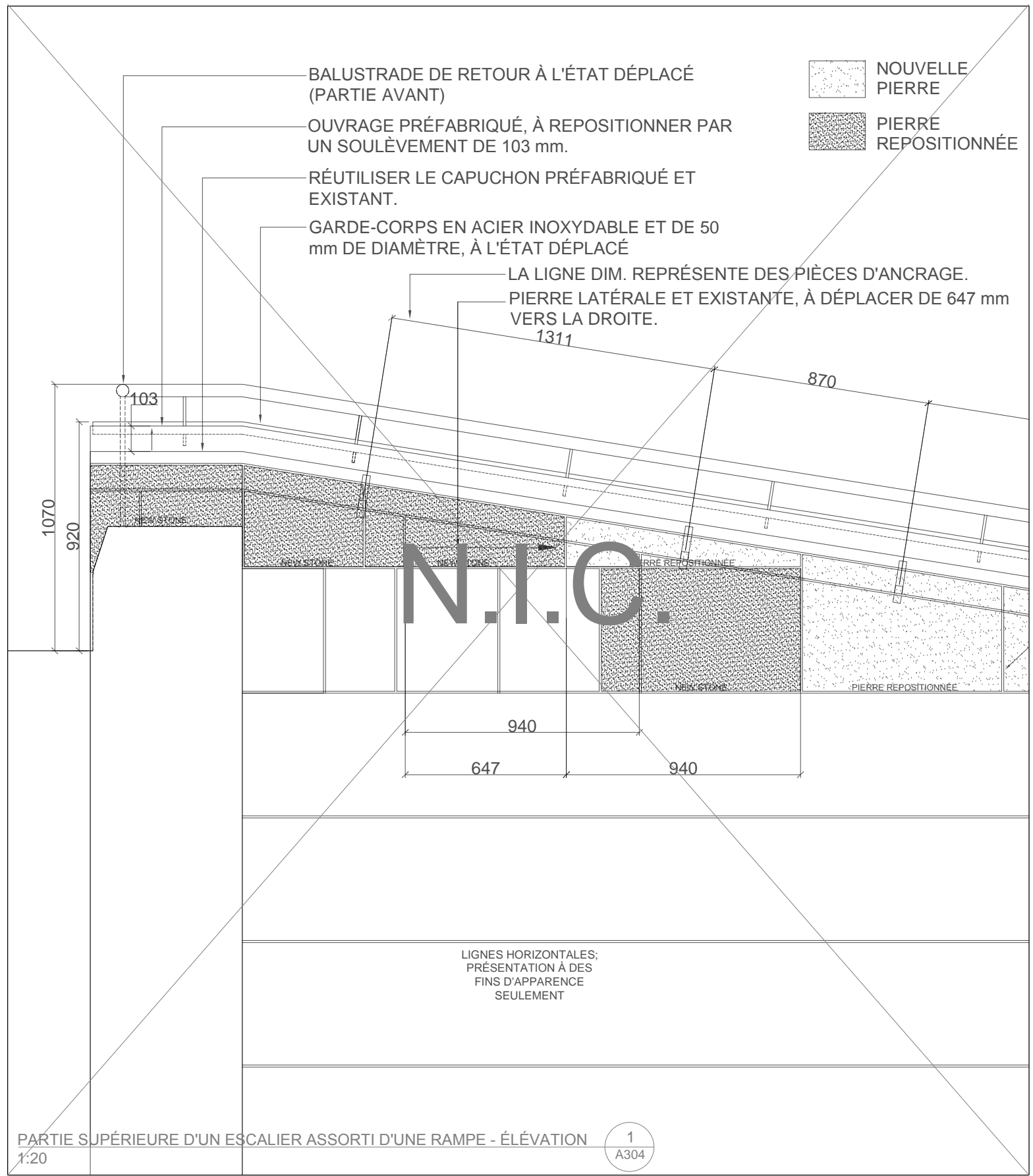

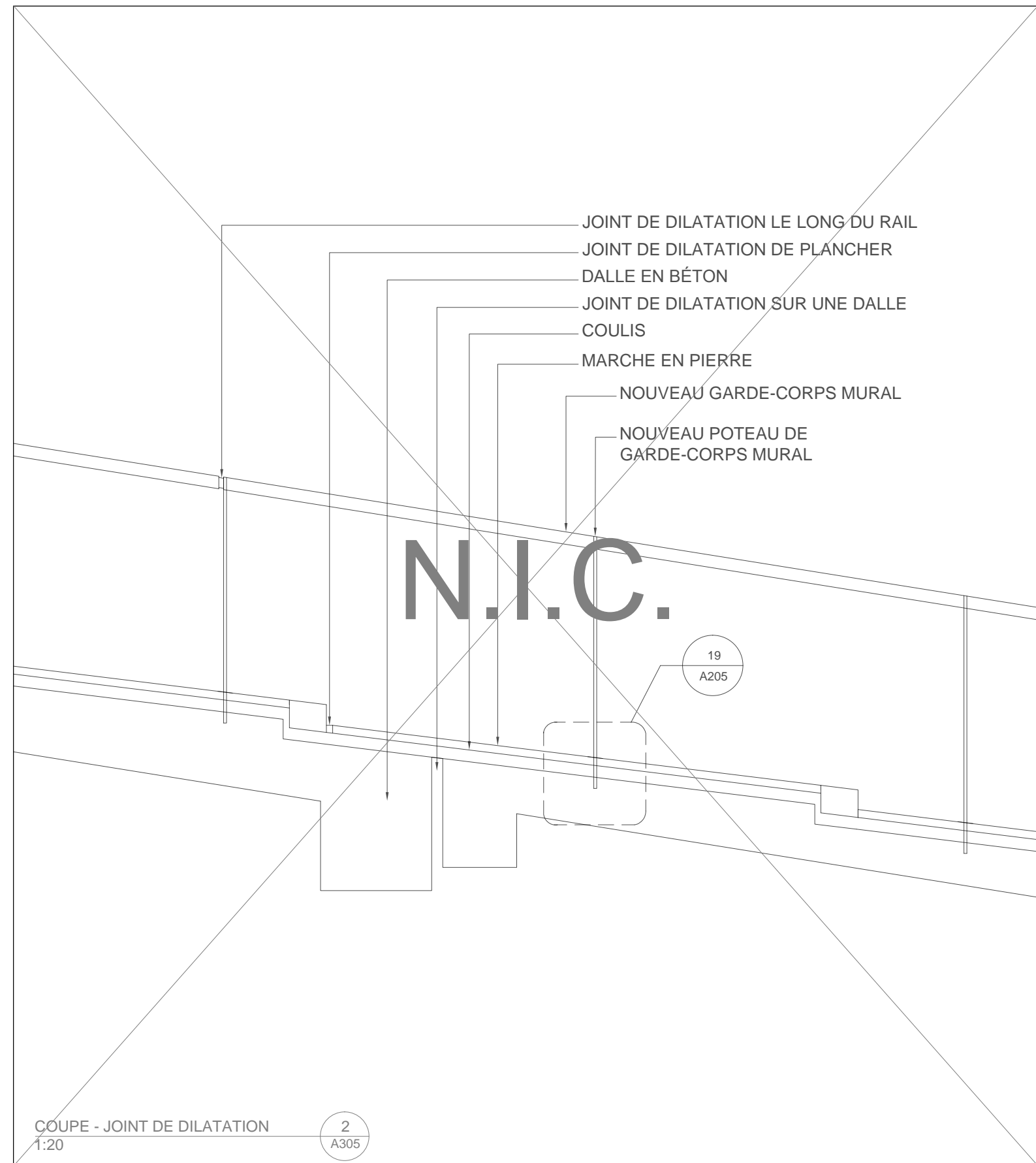
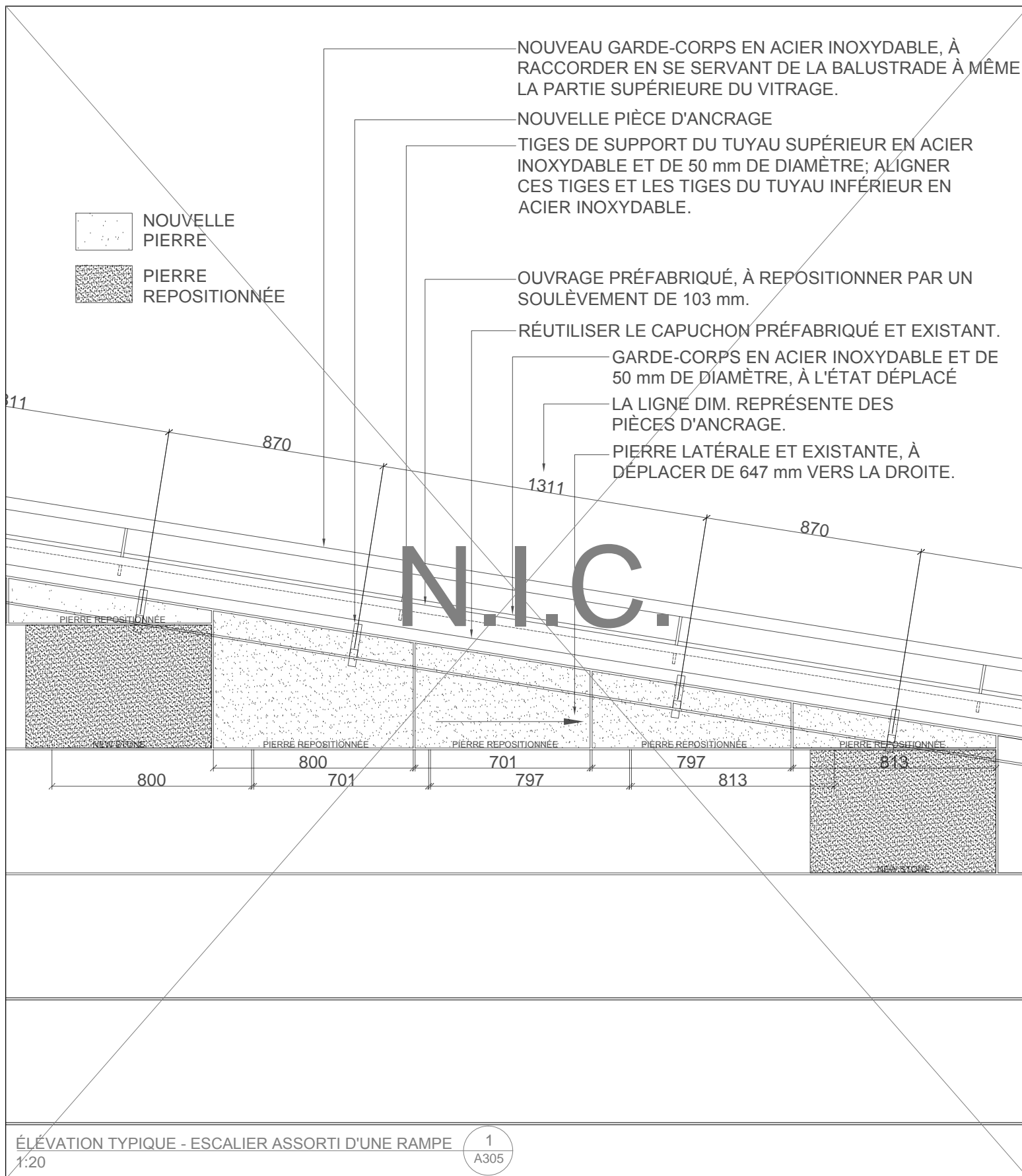

Musée des beaux arts du Canada

A305 - DÉTAIL EN ÉLEVATION D'UN ESCALIER ASSORTI D'UNE RAMPE
ÉCHELLE 1:20

Mises à jour du Code de construction – Phase II A305

LE 15 FÉV. 2017
Moshe Safdie and Associates, Inc.

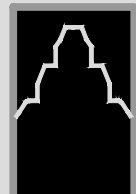
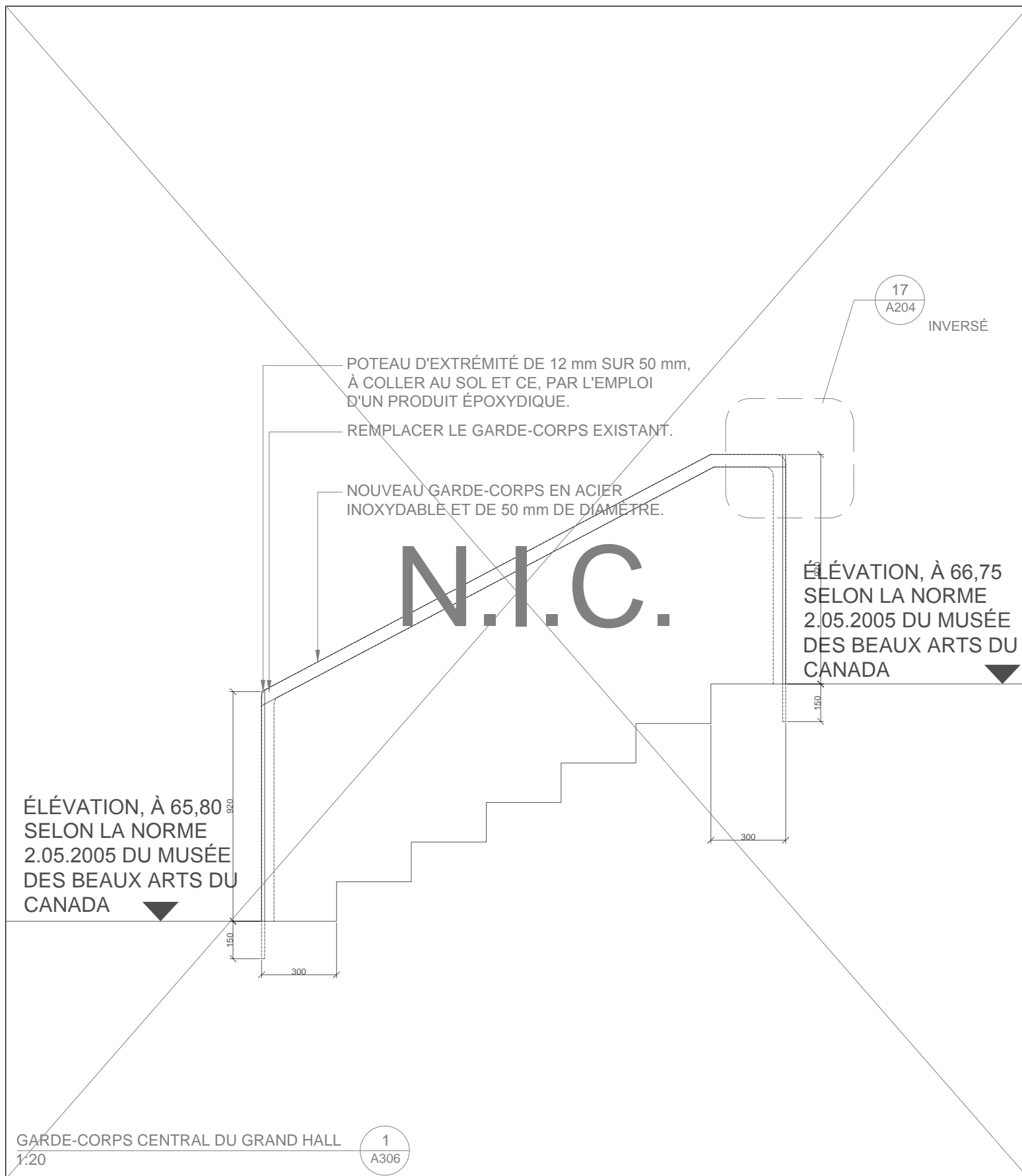

Musée des beaux arts du Canada

A305 - DÉTAIL EN ÉLÉVATION D'UN ESCALIER
ASSORTI D'UNE RAMPE
ÉCHELLE 1 : 20

Mises à jour du Code de construction – Phase II
A306

LE 15 FÉV. 2017
Moshe Safdie and Associates, Inc.