



Fisheries and Oceans
Canada

Pêches et Océans
Canada

Canadian
Coast Guard

Garde côtière
canadienne



SOW – FOUNDATION AND TOWER REPLACEMENT

LL1405 Black Forest Shoal

Lake Joseph, ON

MARITIME AND CIVIL INFRASTRUCTURE

Prepared by: BH

Approved by: BH

Revision: 0

File: EWTM 8010-1405000

Rev Date: 17 JUL 2018



TABLE OF CONTENTS

SECTION:	011100 GENERAL INSTRUCTIONS	1
SECTION:	013300 SUBMITTAL PROCEDURES	7
SECTION:	013530 HEALTH AND SAFETY REQUIREMENTS	8
SECTION:	013543 ENVIRONMENTAL PROCEDURES	10
SECTION:	014500 QUALITY CONTROL.....	13
SECTION:	016100 COMMON PRODUCT REQUIREMENTS	15
SECTION:	024116 DEMOLITION OF STRUCTURES.....	17
SECTION:	033000 CONCRETE WORK	20
SECTION:	055000 METAL WORK	26
SECTION:	133613 METAL TOWERS.....	29
APPENDIX A:	SITE LOCATION AND PHOTOGRAPHS	32
APPENDIX B:	SUMMARY OF SUBMITTALS	36
APPENDIX C:	DRAWINGS.....	37
APPENDIX D:	MARINE ACCESS REQUIREMENTS	43
APPENDIX E:	MANDATORY CRITERIA	46



SECTION: 011100 GENERAL INSTRUCTIONS

PART 1 - GENERAL

1.1 Minimum Standards

- .1 Perform work in accordance with National Building Code of Canada (NBC) and any other code of provincial or local application. In the case of any conflict or discrepancy, the more stringent requirements shall apply
 - .1 Meet or exceed requirements of:
 - .1 Contract documents;
 - .2 Specified standards, codes and referenced documents.

1.2 Description of Work

- .1 Work under this Contract includes but is not limited to the provision of all labour, materials, and equipment required to:
 - .1 Mobilize to site with a work barge of appropriate size and certification;
 - .2 Clearing of rubble to expose bedrock.
 - .1 CCG staff will be on site to determine appropriate location for new tower.
 - .3 Install one [1] new concrete pier;
 - .1 Bidder shall assume water depth of 0.915 m for bidding purposes.
 - .4 Scheduling of concrete testing by CCG acquired third party firm.
 - .5 Transportation and installation of one [1] new CCG supplied 20' aid to navigation (AtoN) tower and 1.2m x 3m dayboard;
 - .6 Salvage and return of the existing tower, complete with all appurtenances to CCG Base Parry Sound;
 - .7 Demolish and dispose of two [2] existing piers; and
 - .8 Demobilize.
- .2 The following work will be undertaken by others and is hereby excluded:
 - .1 Supply one [1] ATON tower and dayboard;
 - .1 Tower and dayboard are to be transported to site from staging location by contractor.
 - .2 Supply and installation of lantern, battery and solar panel onto new ATON tower.



1.3 Submittals

- .1 Mandatory submittals and schedule for submission are detailed below and in Appendix B. The following identifies general requirements only. The relevant sections must be consulted for a complete listing of mandatory content.
- .2 Detailed Schedule:
 - .1 Deadline:
 - .1 No later than ten [10] working days following award.
 - .2 Deliverables:
 - .1 The contractor shall furnish a high level schedule outlining the major construction milestones. Schedule shall clearly define the anticipated start and finish dates of the project.
 - .2 For fieldwork to proceed, all other mandatory submittals must be received and accepted by Coast Guard.
- .3 Mandatory Technical Criteria:
 - .1 Each vessel used by the bidder for this contract must be commercially registered in Canada in the Small Vessel Register (SVR) or the Canadian Register of Vessels (CRV).
 - .2 Deadline:
 - .1 With bid.
 - .3 Deliverables:
 - .1 Copy of registration certificate; and
 - .2 Picture of the vessel with its Official Number visible.
- .4 Proof of Qualifications:
 - .1 Deadline:
 - .1 No later than ten [10] working days following award.
 - .2 Deliverables:
 - .1 The Contractor shall provide the name and contact information for the following project team members:
 - .1 The Project Manager; and
 - .2 The Site Foreman;
 - .2 The contractor shall also provide a detailed list of all subcontractors being used to



complete the work described herein (Section 011100 – 1.4).

.5 Construction Plan:

.1 Deadline:

.1 No less than ten [10] working days prior to mobilization.

.2 Deliverables:

.1 A Construction Plan of sufficient detail to demonstrate that the Contractor has considered all the challenges of the project and is prepared to undertake the works in a competent and professional manner in accordance with all legislation, including:

.1 Project Specific Safety Program (Section 013530);

.2 Project Environmental Protection Plan (Section 013543);

.3 Detailed Demolition Plan (Section 024116);

.4 Dewatering Plan (Section 033000);

.5 Foundation Construction Plan (Section 033000); and

.6 Drilling Plan (Section 055000).

.6 As Built and QA/QC:

.1 Deadline:

.1 No more than twenty eight [28] calendar days after construction.

.2 Deliverables:

.1 The following documents shall be forwarded upon completion of the contract:

.1 Set of red-lined as built drawings.

1.4 Contractor Qualifications

.1 The work shall be carried out under the supervision and responsibility of a sole specialized Contractor, capable of performing installations of offshore drilled foundations.

.2 The Contractor shall designate the following key project members, including any subcontractors. The project members shall have completed projects of similar scope and complexity to the work described herein.

.1 Project Manager: Contact information for the main point of contact for the project shall be provided by the contractor.

.2 The contractor shall provide a detailed list of all subcontractors being used to complete the work described herein.



- .3 Requests to amend the project team, following contract award, must be forwarded in writing. Coast Guard reserves the right to reject any proposal to amend the project team.

1.5 Site Location

- .1 The location of the site is as follows:
 - .1 Lat./Long.: 45° 8'20.43"N, 79°41'50.71"W.
- .2 The closest major settlement is Foot's Bay, Ontario.
- .3 The site is located on a shallow shoal, offshore in Lake Joseph.

1.6 Existing Conditions

- .1 Bidders shall make their own estimate of the difficulties associated with all phases of the works.
- .2 Bidders must include in their costs all expenses related to the difficulties of working at the sites.
- .3 The site is located on a natural rock shoal. Bidder shall consider the nature of the site and shall not assume in any way that the site will be perfectly flat or level. Difficulties associated with working on the natural rock shoal shall be included in the bid price.
- .4 Photographs of the existing site are included in Appendix A.

1.7 Contractor's Access to Site

- .1 Contractor is responsible for transportation of all labour, materials, and equipment to and from the site, including any and all material furnished or itemized for salvage by Coast Guard.
- .2 The site is accessible by water. The site is located on a shoal in Lake Joseph, approximately 3.5 km East of Foot's Bay, ON.
- .3 The Contractor is responsible for sourcing appropriate marine access to support all construction work. Contractors are also responsible for ensuring that all the requirements of Appendix D – Marine Access Requirements are met, failure to do so will result in the bid being deemed non-compliant. Use of vessels other than those approved by Coast Guard is not permitted. All vessels used, no matter how the vessel is used, shall be approved by Coast Guard as meeting the applicable requirements and regulations.

1.8 Completion, Scheduling and Planning of the Works

- .1 Work may commence as early as practical following Coast Guard's acceptance and approval of mandatory submissions.
- .2 Site work shall not commence without written authorization of Coast Guard Project Authority.
 - .1 Advise Coast Guard at least two [2] weeks in advance of proposed installation date.
- .3 Work shall be complete by October 31, 2018.



- .4 Demolition of the existing pier shall not begin until the new tower has been fully commissioned by CCG, as this is a working aid and must remain so during construction.

1.9 Coast Guard Staging Location

- .1 Items to be supplied by, or salvaged to Coast Guard shall be collected or delivered by the Contractor to the following staging location. The Contractor shall be responsible for all transportation costs between the project site and the identified staging location. Material drop off or access to stored goods outside of regular operating hours shall be at the discretion of Coast Guard and may be subject to cost recovery:

- .1 Staging location:

CCG Base Parry Sound
28 Waubeek St.
Parry Sound, ON P2A 1B9

- .2 Advise Coast Guard at least three (3) working days prior to pick-up/delivery
- .3 Shipping/Receiving hours: Monday through Friday, 9:00AM to 3:00PM

1.10 Temporary Facilities

- .1 Provide sanitary facilities for work force in accordance with governing regulations and ordinances.
- .2 Arrange, pay for, and maintain temporary electrical power supply as required for construction, and water supply as required, in accordance with governing regulations and ordinances.
- .3 Maintain emergency spills kit on-site at all times.

1.11 Fees, Permits, Certificates and Information

- .1 Contractor shall provide authorities having jurisdiction with all information requested.
 - .1 Contractor shall provide copies to Coast Guard of any documentation submitted to other authorities related to the work described in this document.
- .2 Contractor shall pay fees and obtain certificates and permits required.
- .3 Contractor shall furnish certificates and permits when requested.

1.12 Reference Documents

- .1 The most recent publication or edition of any document referenced in this specification should be used unless the referencing clause states that this clause does not apply.



Fisheries and Oceans
Canada

Pêches et Océans
Canada

Canadian
Coast Guard

Garde côtière
canadienne



1.13 Required Submissions

- .1 A summary of the minimum mandatory submissions required can be found in Appendix B. This summary is not an exhaustive list of all submissions required for the duration of the project. Additional submissions may be required after award.



SECTION: 013300 SUBMITTAL PROCEDURES

PART 1 - GENERAL

1.1 General

- .1 This section specifies general requirements and procedures for the Contractor's submissions of documents to Coast Guard for review.
- .2 For each phase of the project, work shall not progress until all mandatory submittals required before the start of that phase have been received, reviewed and accepted by Coast Guard
- .3 Where items or information is not produced in SI Metric units, converted values are acceptable.
- .4 Contractor's responsibility for errors and omissions in submission is not relieved by Coast Guard's review of the submitted documents.
- .5 Notify Coast Guard, in writing at time of submission, identifying deviations from requirements of Contract Documents stating reasons for deviations.
- .6 Contractor's responsibility for deviations in submission from requirements of Contract Documents is not relieved by Coast Guard's review of submission, unless Coast Guard gives written acceptance of specific deviations.
- .7 Make any changes to submissions that Coast Guard may require consistent with Contract Documents and resubmit as directed by Coast Guard.
- .8 Provide Coast Guard with a written notice, when resubmitting, of any revisions other than those requested by Coast Guard.

1.2 Submission Requirements

- .1 Coordinate each submission with requirements of work and Contract Documents. Individual submissions will not be reviewed until all related information is available.
- .2 Allow three (3) working days, or as stipulated in the specifications, for Coast Guard to review the submission.
- .3 The Contractor's Engineer shall stamp and sign any submissions requiring a Professional Engineer's seal certifying his approval of samples, verification of field measurements, and compliance with Contract Documents.



SECTION: 013530 HEALTH AND SAFETY REQUIREMENTS

PART 1 - GENERAL

1.1 Scope

- .1 The Contractor shall be responsible to develop, implement and enforce a safety program which addresses all elements of the work.

1.2 References

- .1 Work under this section shall be undertaken in strict conformance with all listed references, In the case of any conflict or discrepancy the more stringent requirements shall apply.
 - .1 Canada Labour Code Part II - January 2008
 - .2 NRC-CNRC National Building Code of Canada
 - .3 Ontario Occupational Health and Safety Act and Regulations, 2009
 - .4 ISO Small Craft Stability Standard 12217-1
 - .5 Canada Shipping Act, 2001
 - .6 Any and all other Provincial/Territorial Regulations and Policies; Worker's Compensation Board Policies; Local municipal regulations; pertaining to safety of the contractors workers.

1.3 Submittals

- .1 Submittals shall be forwarded to Coast Guard in accordance with the provisions of section 013300.
- .2 Project Specific Safety Program
 - .1 Deadline:
 - .1 With Construction Plan.
 - .2 Deliverables:
 - .1 Safety Program Document, include:
 - .1 A listing of all activities specific to this phase of the project and their Health & Safety risks or hazards;
 - .2 Detailed descriptions of how the activities are to be carried out as well as methods for mitigating hazards and risks; and,
 - .3 A listing of personnel responsible for health and safety measures, and emergency procedures.



- .4 Material Safety Data Sheets for hazardous products to be utilized in the execution of the works.
- .2 Proof that a Notice of Project has been filed with the Ontario Ministry of Labour.
- .3 Contractor shall be familiar with O. Reg. 213/91: Construction Projects. Special attention shall be paid to the sections regarding cofferdams and formwork, as related to the project.
- .4 Contractor shall submit completed Field Level Hazard Assessment (FLHA) forms to CCG upon request.

1.4 Existing Conditions

- .1 Existing pier has deteriorated and a gap has formed beneath the existing concrete base making this tower unstable. Contractors must ensure the tower is dismantled and removed in a safe manner.
 - .1 Photos of the existing pier and tower are included in Appendix A.

1.5 Site Condition Upon Departure

- .1 When leaving the site unattended for any duration of time, hazards shall be minimized. These hazards may include but are not limited to the following:
 - .1 Rock anchors and reinforcement exposed prior to concrete pour;
 - .2 Open forms, cofferdams, or enclosed spaces.
 - .1 Access to these areas shall be restricted when possible, as per industry best practices.
- .2 All materials left at site shall be secured in place prior to departure.



SECTION: 013543 ENVIRONMENTAL PROCEDURES

PART 1 - GENERAL

1.1 Scope of Work

- .1 The Contractor must implement and enforce the following procedures throughout the duration of the work to mitigate potential negative impacts on the surrounding environment.

1.2 References

- .1 Work under this section shall be undertaken in strict conformance with all listed references, In the case of any conflict or discrepancy the more stringent requirements shall apply.

- .1 Canadian Environmental Protection Act
- .2 Canadian Council of Ministers of the Environment (CCME) Documentation
- .3 Canadian General Standards Board (CGSB)

1.3 Submittals

- .1 Submittals shall be forwarded to Coast Guard in accordance with the provisions of section 013300.
- .2 Contractor shall submit an environmental protection plan.
 - .1 Deadline:
 - .1 With Construction Plan.
 - .2 Deliverables:
 - .1 Submit a plan addressing procedures to be implemented to mitigate any negative impact on the environment. Detail:
 - .1 Equipment features (age, spill containment);
 - .2 Staging, refueling, and cleaning areas;
 - .3 Clean-up and/or containment procedures (including concrete/grout);
 - .4 Waste disposal methods and sites;
 - .5 De-watering plan.



PART 2 - PRODUCTS

2.1 General

- .1 Avoid use of hazardous products. Use environmentally friendly products where practical.

PART 3 - EXECUTION

3.1 Construction Area

- .1 Confine construction activities to as small an area as practical.
- .2 Establish material storage, cleaning, and refueling areas where impacts to the surrounding environment will be negligible or readily mitigated.

3.2 Stockpiling of materials

- .1 Materials must be stockpiled as far from the shoreline as practical. Tarps must be used to control dust and run-off.
- .2 Stockpiled excavated materials shall be skirted using filter fabric to control run-off of fines during rain.

3.3 Disposal of Wastes

- .1 Clean-up the site at the end of each working day.
- .2 All waste material to be disposed of in a legal manner at a site approved by local authorities. Transporter/hauler must be appropriately licensed.
 - .1 Recycle or reuse materials where possible.
- .3 Fires and burning of rubbish on site not permitted.
- .4 Do not bury rubbish and waste materials on site.
- .5 Waste materials must not enter watercourse in any capacity.

3.4 Drainage

- .1 Provide temporary drainage and pumping as necessary to keep excavations and site free from water.
 - .1 Suspend works during periods of heavy rainfall and add temporary covers to discourage run-off.
 - .2 Water pumped from excavation shall be adequately treated to ensure that water returning to the watercourse contains minimal fines. Procedures anticipated for preventing the pumping of fines shall be identified in the environmental protection plan, and may include the following:



- .1 The use of filter bags;
- .2 Straw bale check dams or silt fence;
- .3 The means for controlling silt run-off shall be dependent on the site and the quantity of water pumped, and shall be to the discretion of the CCG site staff.
- .4 Sediment control measures shall be inspected and improved/cleaned/replaced as necessary.

3.5 Pollution Control

- .1 Provide methods, means, and facilities to prevent the contamination of soil, water, and atmosphere from the discharge of pollutants produced by construction operations.
- .2 Vehicles, machinery, and equipment shall be in good repair, equipped with emission controls as applicable and operated within regulatory requirements.
- .3 Abide by local noise by-laws.
- .4 Avoid unnecessary idling of vehicles or heavy machinery.
- .5 Limit use of equipment around the shoreline where possible.
- .6 Implement and maintain dust and particulate control measures in accordance with provincial requirements:
 - .1 All bulk material haul equipment shall be appropriately tarped. Watertight vehicles shall be used to haul wet materials.
- .7 Designate a cleaning area for tools to limit water use and runoff. Do not allow deleterious materials to enter waterways. Ensure emptied containers are sealed and stored safely for disposal.
- .8 The contractor shall take all necessary precautions to guard against the release of any noxious substance or pollutant to the environment. In the event of any spill the Contractor shall take immediate action to contain the release and mitigate any impact.
 - .1 Materials and equipment to intercept contain, and clean-up any spill or other release shall be maintained on site throughout the construction period and must be readily accessible at all times.
 - .2 Any uncontrolled release of a known contaminant (spills, fire/smoke) shall be reported to appropriate Provincial Authority and Coast Guard. Spills of deleterious substances to be immediately contained and cleaned up in accordance with provincial regulatory requirements.
 - .3 Provincial Authority: Ontario Spills Action Centre 1-800-268-6060.



SECTION: 014500 QUALITY CONTROL

PART 1 - GENERAL

1.1 Inspection

- .1 Canadian Coast Guard (CCG) or its representative shall have access to the work at all times. If parts of the work are prepared off-site or in a shop, access shall be given to such work throughout the duration of the project.
- .2 In the event the work must be submitted to special testing, inspection or approvals prescribed by CCG in these specifications or provided for in work-site regulations, the request for inspection must be made without unreasonable delay.
- .3 The below list identifies key milestones where the CCG will require an opportunity to take samples/inspect:
 - .1 Location verification: Coast Guard will confirm correct location for installation upon arrival of the contractor at site. The contractor shall be required to provide access to the site at all times to CCG site staff.
 - .2 Drilling: Coast Guard shall witness the drilling and epoxying of holes for vertical rebar installation.
 - .3 Concreting: Coast Guard shall verify rebar placement before concrete pour and witness concrete pour and testing.
 - .4 Installation of tower: Coast Guard shall witness the erection of the new nav-aid tower.

1.2 Procedures

- .1 Provide CCG with advance notice whenever testing is required in accordance with these specifications, so that all parties involved can be present.
- .2 Provide necessary manpower and installations for obtaining and handling samples and material on site.
- .3 Provide access to site if the site is of remote nature whereby the contractor is responsible for providing access to the site.

1.3 Rejected Work

- .1 Remove defective work, whether incorporated into the work or not, which has been rejected by CCG as failing to comply with the contract documents. Replace or re-execute in accordance with the Contract Documents.

1.4 Tests and Mixture Formulas

- .1 Supply test reports and required mixture formulas.



Fisheries and Oceans
Canada

Pêches et Océans
Canada

Canadian
Coast Guard

Garde côtière
canadienne



1.5 Factory Tests

- .1 Submit test certificates as prescribed in the relevant section of the specifications.

1.6 Acceptance of Work

- .1 CCG will make acceptance visits of work executed by the Contractor at critical milestones identified in the following sections.
- .2 The Contractor shall inform CCG at least three (3) working days before these inspection visits.
- .3 All work shall be completed in compliance with the specifications before requesting the visit for inspection, or completed during the visit if work is requested to be witnessed. If the work is not completed or deemed non-compliant, the Contractor shall be responsible for all costs incurred for subsequent inspections.



SECTION: 016100 COMMON PRODUCT REQUIREMENTS

PART 1 - GENERAL

1.1 General

- .1 Secure Coast Guard approval of all products to be incorporated into the works. Work shall not commence until product data and/or samples have received Coast Guard approval.
- .2 Supply and/or fabricate material and equipment of prescribed quality, with performance conforming to established standards.
- .3 Use new material and equipment unless otherwise specified.
- .4 Ensure replacements parts may be readily procured.
- .5 Use products from one manufacturer for material and equipment of same type or classification, unless otherwise specified.

1.2 Manufacturer's Instructions

- .1 Unless otherwise specified, comply with manufacturer's latest printed instructions for materials and installation methods.
- .2 Notify CCG in writing of any conflict between these specifications and manufacturer's instructions; CCG will designate which document is to be followed.

1.3 Compliance

- .1 When material or equipment is specified by standard or performance specifications, upon request of CCG, obtain an independent testing laboratory report from the manufacturer, stating that material or equipment meets or exceeds specified requirements.

1.4 Substitution

- .1 Where specific products have been specified, proposals for substitution may only be submitted after award of contract. Such requests must include statements of respective costs of items originally specified and the proposed substitution.
- .2 No substitutions will be permitted without prior written approval of CCG. Substitutions will be considered by CCG only when:
 - .1 Materials specified in Contract Documents, are not available; or,
 - .2 Delivery date of materials selected from those materials specified would unduly delay completion of contract; or,
 - .3 Alternative materials to those specified which are brought to the attention of and considered by CCG as equivalent to the material specified will result in a credit to the Contract amount.



Fisheries and Oceans
Canada

Pêches et Océans
Canada

Canadian
Coast Guard

Garde côtière
canadienne



- .3 Should the proposed substitution be accepted either in whole or in part, the Contractor must assume full responsibility and costs when such substitution affects other work on the project including any and all design or drawing changes required as a result of substitution.

1.5 Submittals

- .1 Provide product specifications and/or samples upon request from Coast Guard.



SECTION: 024116 DEMOLITION OF STRUCTURES

PART 1 - GENERAL

1.1 Scope of Work

- .1 Work under this section consists of the provision of all labour, materials, and equipment necessary to complete the following activities:
 - .1 Salvage and transport of existing tower, lighting equipment and all related appurtenances to Parry Sound CCG Base;
 - .2 Demolition of two [2] existing concrete piers;
 - .3 Disposal of all waste at a licensed waste disposal facility.

1.2 References

- .1 Work under this section shall be undertaken in strict conformance with all listed references. In the case of any conflict or discrepancy the more stringent requirements shall apply.
 - .1 Canada Labour Code Part II - January 2008
 - .2 NRC-CNRC National Building Code of Canada 2015
 - .3 Ontario Occupational Health and Safety Act and Regulations, 2016
 - .4 CSA S350-[M1980(R1998)], Code of Practice for Safety in Demolition of Structures.

1.3 Submittals

- .1 Submittals shall be forwarded to Coast Guard in accordance with the provisions of section 013300.
- .2 Contractor to provide Demolition Plan.
 - .1 Deadline:
 - .1 With Construction Plan.
 - .2 Deliverables:
 - .1 Method of demolition including all associated tasks and schedule;
 - .2 Methods for protecting the site from demolition debris;
 - .3 The ultimate disposal location of all waste materials and debris.
 - .1 Include documentation detailing regulatory approval for waste disposal facility and transporter.



- .3 Work under this section shall not proceed until written approval of the demolition plan has been received from the Coast Guard.
- .4 Submit copies of certified receipts from the disposal sites for all material removed from the work site upon request.

1.4 Existing Conditions

- .1 Existing pier has deteriorated and a gap has formed beneath the existing concrete base making this tower unstable. Contractors must ensure the tower is dismantled and removed in a safe manner.
 - .1 Photos of the existing pier and tower are included in Appendix A.

PART 2 - PRODUCTS

- 2.1 Not used.

PART 3 - PART 3 - EXECUTION

3.1 General

- .1 Work under this section shall be performed following the installation of the new tower and commissioning unless otherwise approved by Coast Guard.
- .2 If possible, piers shall be lifted onto the barge in one piece to avoid environmental issues.
- .3 Demolition work shall not commence until the new pier and aid to navigation are complete and operational.
 - .1 Schedule shall provide CCG 2-3 days to install lantern and appurtenances onto new tower before beginning demolition of the existing tower.

3.2 Protection

- .1 Implement effective controls to catch/collect all tower debris during demolition.
- .2 Implement effective controls to prevent injury to workers, and mariners.

3.3 Preparation

- .1 Erect warning signs and barricades as applicable.
- .2 Ensure all environmental protection/mitigation measures are in place.
- .3 Ensure all items identified for salvage have been removed and stored.

3.4 Demolition

- .1 Salvage existing tower including all lighting equipment and related appurtenances. Ensure that lighting equipment and related appurtenances do not get damaged.



- .2 Demolish existing concrete foundation in its entirety.
 - .1 All existing exposed rebar shall be cut flush to grade.
- .3 Ensure that demolition does not adversely affect adjacent watercourses, groundwater and wildlife, or contribute to excess air and noise pollution.
- .4 Ensure demolition is undertaken safely. If at any period during demolition the safety of the Contractor's staff cannot be maintained take preventative measures, stop work and immediately notify Coast Guard.

3.5 Disposal

- .1 All material not marked for salvage is to be disposed of off-site and a licensed disposal/recycling facility.



SECTION: 033000 CONCRETE WORK

1.1 Scope of Work

- .1 Work of this section includes the supply of all labour, material, and equipment, necessary to complete the following:
 - .1 Installation of concrete foundation as per appended STEM foundation drawings.
 - .1 A southern design with water depth of 0.915 m shall be assumed for bidding purposes.
 - .1 The actual water depth measured in June 2018 at one location suitable for tower erection on the shoal was approximately 0.45 m. High water level is estimated to be 0.915 m. The entire shoal was not measured during the site visit, just one test location.
 - .2 A square or round pier design is to be chosen by the Contractor and the choice should be noted in the submitted Foundation Construction Plan.
 - .2 Any and all provisions necessary to ensure that the anticipated performance of the placed concrete will be obtained regardless of conditions under which pour occurs.

1.2 References

- .1 Work under this section shall be undertaken in strict conformance with all listed references. In the case of any conflict or discrepancy, the more stringent requirements shall apply.
 - .1 Canada Labour Code Part II
 - .2 NRC-CNRC National Building Code of Canada
 - .3 Ontario Occupational Health and Safety Act and Regulations
 - .4 CAN/CSA A23.1 Concrete Materials and Methods of Concrete Construction
 - .5 CAN/CSA A23.2 Methods of Test and Standard Practices for Concrete
 - .6 CAN/CSA S269.3 Concrete Formwork
 - .7 ACI Specification 306 Cold Weather Concreting (if relevant)

1.3 Submittals

- .1 Submittals shall be forwarded to Coast Guard in accordance with the provisions of section 013300.
- .2 Dewatering Plan (if relevant):
 - .1 Deadline:
 - .1 With Construction Plan



- .2 Deliverables:
 - .1 Cofferdam and/or other relevant drawings
 - .1 Drawings must detail:
 - .1 Plan, elevation and relevant section views of the proposed installation;
 - .2 Any pertinent commentary concerning construction and implementation of dewatering plan.
 - .2 Summary Report (if necessary):
 - .1 The summary report shall contain all additional technical references and requirements not otherwise detailed within the engineered drawings.
- .3 Foundation Construction Plan:
 - .1 Deadline:
 - .1 With Construction Plan
 - .2 Deliverables:
 - .1 Provide high level summary of mix properties and admixtures to demonstrate compliance with CCG criteria and STEM foundation design;
 - .2 Provide MSDS, (pre-mixed products only).
 - .3 Concrete placement methods and curing procedures, detail:
 - .1 Source of concrete, including mix plan;
 - .2 Shop drawings for formwork and false-work;
 - .3 Placement methods and procedures to control consolidation/segregation;
 - .1 If dewatering will not occur, tremie concrete pour details must be provided to CCG.
 - .4 Location of necessary cold joints;
 - .5 Finishing procedures;
 - .6 Mill test certificates for rebar, piles or any other steel used in the foundations;
 - .7 Curing methods and schedule;
 - .8 Strength requirements for structural stability (removal of forms);
 - .9 Clean-up procedures;



- .10 Mitigation measures to account for hot or cold temperatures where reasonably anticipated during the construction period.

.4 As-built and Quality Control

.1 Deadline:

- .1 28 days following completion of construction activities

.2 Deliverables:

- .1 Red-lined drawings showing all changes from the sealed design drawings (if any);

- .1 Drawing or sketch indicating the position of the constructed pier relative to the former installation, detail:

- .1 Height of former pier, bedrock to top of foundation;
- .2 Difference in elevation from top of former pier to top of new pier;
- .3 Highest high water mark of indicated former pier, relative to bedrock grade;
- .4 Height of new pier, bedrock to top of foundation;
- .5 Water level above bedrock for new pier;
- .6 Horizontal offsets to the center of new pier (north, south, east, & west) relative to former pier.

- .2 Concrete test results.

1.4 Quality Assurance

- .1 Coast Guard's minimum inspection requirements are detailed herein.
- .2 The Contractor shall be responsible to notify Coast Guard of the date and time that the works may be inspected. Notice must be provided no less than three [3] working days in advance to permit scheduling of quality assurance testing.
- .3 All deficiencies in the works identified at the time of inspection shall be remedied to the satisfaction of Coast Guard, at the Contractors expense. Work shall not progress until inspections have been completed and the Contractor has been provided with written notice to proceed with the works.
- .4 The below list identifies key milestones for which Coast Guard will require an opportunity to take samples, inspect or witness testing:
 - .1 Upon completion of formwork and placement of reinforcement.
 - .2 During execution of concrete placement.
- .5 The Contractor shall be responsible to arrange for concrete testing on site the day of the pour.



- .1 Once a project schedule is received, Coast Guard will hire a company to carry out concrete testing on the day of the pour. The work will include at minimum a test for slump, air entrainment and strength (three [3] cylinders: one [1] 7-day, and two [2] 28-day).
- .2 It shall be the Contractor's responsibility to schedule the concrete testing from that point forward.
- .3 Extra concrete cylinders shall be cast and broken to determine foundation strength prior to tower erection.

PART 2 - PRODUCTS

2.1 General

- .1 All materials shall conform to requirements of CAN/CSA-A23.1 and appended STEM drawings.

2.2 Formwork

- .1 Shall be in accordance with CAN/CSA S269.3.
 - .1 If formwork is to be dewatered, formwork should be watertight.

2.3 Concrete

- .1 Concrete shall possess the minimum characteristic detailed in the Contract Drawings and attached STEM foundation drawings, provided in Appendix C.
 - .1 Concrete employed shall be locally available ready-mix concrete supplied by a RMCAO certified batch plant.
 - .2 Alternatively pre-proportioned or bagged concrete to be approved by Coast Guard.
- .2 For concrete placement via tremie method, concrete supplier must verify concrete mix is intended for use in a tremie application.

2.4 Water

- .1 Water utilized for the production of concrete must be potable, unless otherwise approved in writing by Coast Guard.

PART 3 - EXECUTION

3.1 General

- .1 Concrete must be placed, finished, and cured in accordance with the Contractor's submitted construction plan.
 - .1 Ensure that the top of the concrete is no less than 600 mm (24 in) above high water level.
- .2 Installation shall be undertaken in accordance with attached STEM foundation drawings and contractors concrete placement plan.



- .3 Exposed concrete edges shall be chamfered.
 - .1 If cylindrical design is chosen top edge to be rounded over with use of hand trowel or equivalent.

3.2 Preparation

- .1 Preparation shall not commence until bearing surfaces have been inspected by Coast Guard.
- .2 Remove all loose and deleterious material.
- .3 Construct forms as detailed in the submitted construction plan.
- .4 Place reinforcement in accordance with Contract Drawings.
- .5 Concrete cover must be as indicated in the attached STEM foundation drawings.

3.3 Placement

- .1 Concrete placement shall not commence until formwork and reinforcement have been inspected by Coast Guard.
- .2 Contractor shall place finish and cure concrete as per CAN/CSA A23.1 making all adjustments necessary to account for climatic conditions anticipated during the curing period.
- .3 Concrete shall be placed in one continuous pour.
 - .1 The development of cold joints shall be avoided. Alternatively, cold joints must be previously approved in writing by CCG.
- .4 Finish exposed concrete surfaces to provide a lightly brushed non-skid surface.
- .5 Cut control joints where specified.
- .6 Contractor shall provide samples as required during placement operation for the performance of quality assurance testing.
- .7 Concrete shall be finished so as to slope gently away from the center of the slab. No water shall pond on the finished surface.
- .8 All exposed 90° edges shall be chamfered.

3.4 Curing

- .1 Shall be undertaken in accordance with CAN/CSA A23.1 and the Contractor's approved Construction Plan.
 - .1 Curing regiment employed must take into account local climatic conditions reasonably anticipated to occur during the curing period.



Fisheries and Oceans
Canada

Pêches et Océans
Canada

Canadian
Coast Guard

Garde côtière
canadienne



3.5 Grout

- .1 Supply and install load bearing grout between the top of the completed foundation and the tower base/anchor plate.
- .1 Edges of grout shall be chamfered.



SECTION: 055000 METAL WORK

1.1 Scope of Work

- .1 Work of this section includes the supply of all labour, material, and equipment, necessary to complete the following activities:
 - .1 Drilling and installation of vertical bars in to competent bedrock as per STEM foundation drawings;
 - .1 Fabrication and installation of foundation reinforcing cage as per STEM foundation drawings.

1.2 References

- .1 Work under this section shall be undertaken in strict conformance with all listed references, In the case of any conflict or discrepancy the more stringent requirements shall apply.
 - .1 Canada Labour Code Part II - January 2008
 - .2 NRC-CNRC National Building Code of Canada 2010
 - .3 Ontario Occupational Health and Safety Act and Regulations
 - .4 CAN/CSA G40.20-13 – General Requirements for Rolled or Welded Structural Quality Steel
 - .5 CAN/CSA G164 - Hot Dip Galvanizing of Irregularly Shaped Articles
 - .6 CAN/CSA A13.1-04 - Concrete Materials and Methods of Concrete Construction
 - .7 ASTM A36-14 - Standard Specification for Carbon Structural Steel
 - .8 ASTM A615-15 – Standard Specification for Deformed and Plain Carbon-Steel Bars for Concrete reinforcement

1.3 Submittals

- .1 Submittals shall be forwarded to Coast Guard in accordance with the provisions of section 013530.
- .2 Drilling Plan:
 - .1 Deadline:
 - .1 With Construction Plan.
 - .2 Deliverables:
 - .1 Description of the equipment that will be utilized to drill into bedrock;



- .2 Description of the methods that will be implemented to stabilize the drilling equipment, and to ensure verticality of holes;
 - .3 Description of how epoxying activities will occur;
 - .4 Provide material specifications for the epoxy adhesive to be used;
 - .5 Provide cut-sheets for the reinforcing bars to be used;
 - .6 Describe how works will be undertaken to mitigate impacts on the surrounding watercourse.
- .3 As Built Drawings:
- .1 Deadline:
 - .1 28 Calendar days following the acceptance of the works.

1.4 Quality Assurance

- .1 Coast Guards minimum inspection requirements are detailed below. The Contractor shall be responsible to notify Coast Guard of the date and time that the works may be inspected. Notice must be provided no less than three (3) working days in advance to permit scheduling of quality assurance testing. All deficiencies in the works identified at the time of inspection shall be remedied to the satisfaction of Coast Guard, by the Contractor at their expense. Work shall not progress until inspections have been completed and the Contractor has been provided with written notice to proceed with the works.
 - .1 Coast Guard is to confirm location of foundation prior to drilling;
 - .2 Coast Guard is to witness drilling and epoxying of vertical bars;
 - .3 Coast Guard must inspect reinforcing cage prior to concrete placement.

PART 2 - PRODUCTS

2.1 Anchor bolts, accompanying washers & nuts

- .1 All anchor bolts and accompanying appurtenances must be hot dip galvanized with minimum yield strength of 400 MPa, conforming to ASTM A325;
 - .1 Anchor bolts to be supplied as per STEM drawing, CCG must be notified as to style of anchor bolt.

2.2 Reinforcing Steel and Vertical Bars

- .1 Reinforcing steel and vertical bars shall conform to the attached drawings and to the following standards:
 - .1 CAN/CSA A23.1-04 - Concrete Materials and Methods of Concrete Construction



.2 CAN/CSA-G30.18-09 - Carbon Steel Bars for Concrete Reinforcement

.2 All reinforcing steel and vertical bars are to be epoxy coated as per CSA-G30.18-09;

.1 Reinforcing cage to be tied with plastic or plastic coated rebar tie wire.

2.3 Epoxy Adhesive

.1 Epoxy Adhesive used for vertical bars to be HILTI HIT-RE 500 V3 as per STEM drawings;

.1 Alternates must be approved by Coast Guard.

PART 3 - EXECUTION

3.1 Fabrication

.1 Fabricate and install reinforcing cage as shown in the appended drawings.

.2 Vertical rebar to be epoxied into bedrock and cured prior to installation of remaining rebar.

.3 Hot dip galvanizing shall conform to CAN/CSA G164, most recent edition.

3.2 Installation

.1 Installation shall be carried out as per the installation directions on the appended drawings.

.2 The location for foundation placement to be verified by on-site CCG staff.

.3 The elevation of the top of the pier will be as determined by CCG staff and by the Engineer on Record. Please refer to foundation drawing in Appendix C for more information.

.1 Provisions shall be made to allow for variance in the lengths of the drilled rebar from that of the drawings, based on water depth and field conditions. Rock shall not be assumed to be flat.

.1 A southern design with water depth of 0.915 m can be assumed for bidding purposes.

.2 A square or round pier design is to be chosen by the Contractor and the choice should be noted in the submitted Foundation Construction Plan.



SECTION: 133613 METAL TOWERS

PART 1 - GENERAL

1.1 Scope of Work

- .1 Work under this section includes the supply of all labour, material, and equipment required to complete:
 - .1 The transportation of the tower, dayboard and all associated hardware to site from the designated staging area;
 - .2 The installation of the 20' tower and 1.2m x 3m dayboard detailed in the appended Contract Drawings and photos;
- .2 Work of this section excludes:
 - .1 The installation of a lantern on the tower, and confirmation of proper operation;
 - .2 Fabrication and supply of the tower, to be undertaken by CCG;
 - .3 Supply of the navigational lantern, battery box and batteries will be undertaken by CCG.

1.2 References

- .1 Work under this section shall be undertaken in strict conformance with all listed references. In the case of any conflict or discrepancy the more stringent requirements shall apply.
 - .1 Canada Labour Code Part II
 - .2 NRC-CNRC National Building Code of Canada
 - .3 CSA S37-13 - Antenna Towers and Antenna Supporting Structures
 - .4 CAN/CSA S16.1 - Limit States Design of Steel Structures
 - .5 CAN/CSA G164 - Hot Dip Galvanizing of Irregularly Shaped Articles

1.3 Quality Assurance

- .1 Coast Guard's minimum inspection requirements are detailed below. The Contractor shall be responsible to notify Coast Guard of the date and time that the works may be inspected.
 - .1 Notice must be provided no less than three (3) working days in advance to permit scheduling of quality assurance testing.
 - .1 All deficiencies in the works identified at the time of inspection shall be remedied to the satisfaction of Coast Guard, by the Contractor at their expense.
 - .2 Work shall not progress until inspections have been completed and the Contractor has been provided with written notice to proceed with the works:



- .2 Upon completion of the work an inspection will take place to ensure tower is plumb.

PART 2 - PRODUCTS

2.1 Materials

.1 Steel:

- .1 The tower is structural grade steel 350W and 300W.

.2 Coatings:

.1 Galvanizing:

- .1 All materials, structural steel, pipe and fittings, including bolts, nuts and washers shall be hot dip galvanized to the requirement of the National Building Code, CAN/CSA S16.1, and CSA-G164 and as otherwise specified therein.

PART 3 - EXECUTION

3.1 Fabrication

- .1 Fabrication has been completed by the CCG. This includes everything shown on the drawing which comprises the tower in Appendix C.

3.2 Protective Coatings

.1 Galvanizing:

- .1 The tower and all hardware are hot dip galvanized. The contractor shall be prepared to make repairs to the coating as needed.

3.3 Handling of Material and Transportation

- .1 Estimated weight of the tower is 375 kg (825 lbs). Estimated weight of dayboard is 25 kg (55 lbs).
- .2 The Contractor shall take all necessary precautions to avoid damage to the tower members or to tower coating during transport, unloading and erection. All components or damaged members shall be replaced to the satisfaction of Coast Guard at the expense of the Contractor.
- .3 It is the responsibility of the Contractor to ensure that the tower sections, particularly the joints are protected from bending and alignment damage.
- .4 The contractor will be asked to identify how he would like the tower packaged for shipping shortly after award. This will be coordinated by CCG.

3.4 Placement of Tower

- .1 The tower shall be fitted to foundation anchor rods



Fisheries and Oceans
Canada

Pêches et Océans
Canada

Canadian
Coast Guard

Garde côtière
canadienne



- .2 Each bolt shall have one [1] heavy hex levelling nut below tower base and two [2] heavy hex nuts above base.
 - .1 Heavy flat washers shall be placed between heavy hex nuts and tower base.
- .3 Levelling nuts shall be placed to provide 50 mm gap between pier and tower base.
- .4 Contractor shall tighten the first nut using turn of nut method associated to the length of bolt provided. The second nuts shall be snug tight to lock into place the two nuts.
- .5 Non-shrink, gassing, cementitious grout shall be placed between top of foundation and tower base.
 - .1 Sika M-Bed Standard or equal.



APPENDIX A: SITE LOCATION AND PHOTOGRAPHS

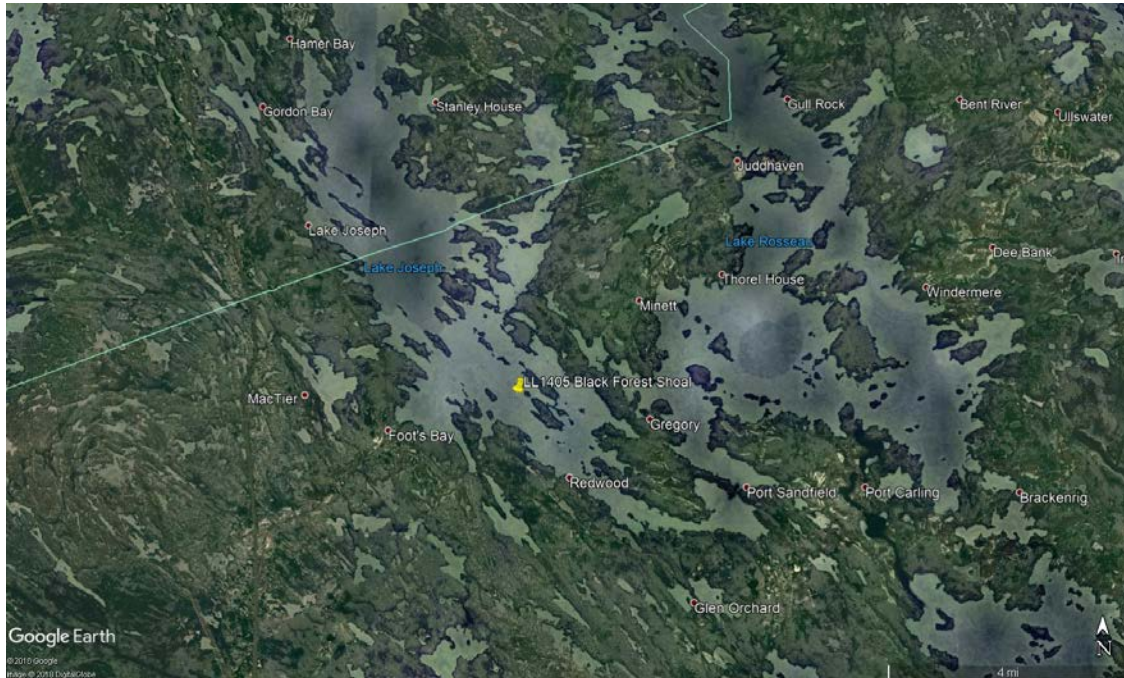

Figure 1: Project Site
45° 8'20.43"N, 79° 41'50.71"W



Figure 2: Project Site



Fisheries and Oceans
Canada

Pêches et Océans
Canada

Canadian
Coast Guard

Garde côtière
canadienne

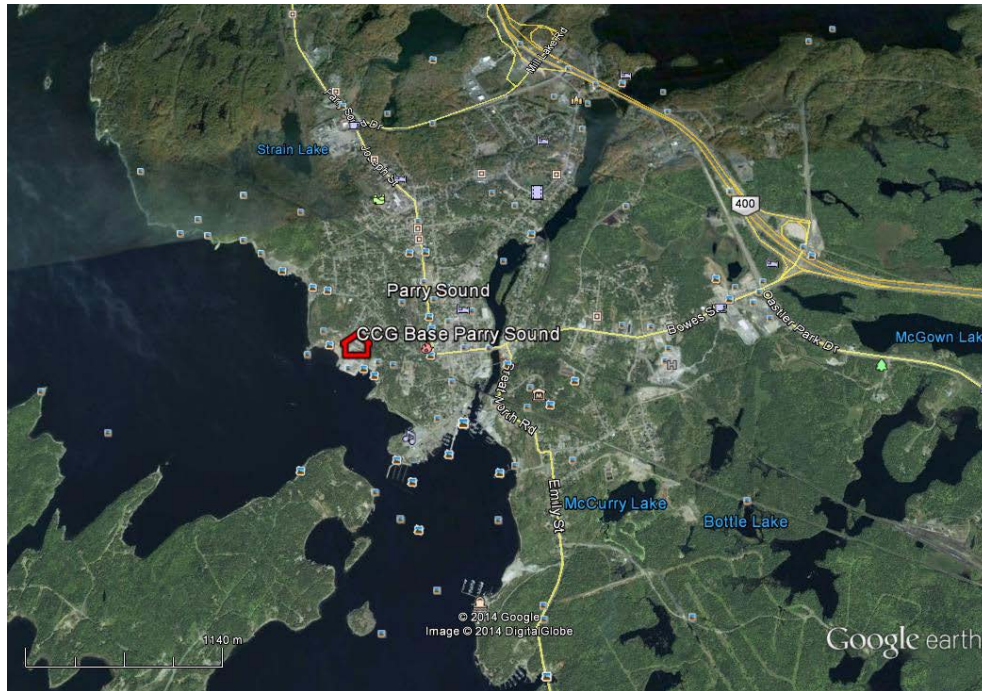

Figure 3: Coast Guard Staging Location
CCG Base Parry Sound
28 Waubeek St. Parry Sound, ON P2A 1B9
45°20'38.93" N - 80°2'34.46" W



Figure 4: Coast Guard Staging Location



Fisheries and Oceans
Canada

Pêches et Océans
Canada

Canadian
Coast Guard

Garde côtière
canadienne



Figure 5: Existing Navaid with Current and Abandoned Foundations, Both to be Removed



Fisheries and Oceans
Canada

Pêches et Océans
Canada

Canadian
Coast Guard

Garde côtière
canadienne



Figure 6: Existing Weathered Piers (To be Removed)



Figure 7: Rock Shoal Conditions



APPENDIX B: SUMMARY OF SUBMITTALS

Following Contract Award

Deadline	Submission Description	Reference Section(s)
With Bid	Mandatory Technical Criteria	011100 – 1.3.3
10 working days following award	Detailed schedule	011100 – 1.3.2
	Proof of Qualifications	011100 – 1.3.4
10 working days prior to mobilization	Construction Plan	
	a) Project Specific Safety Program	013530 – 1.3.2
	b) Project Environmental Protection Plan	013543 – 1.3.2
	c) Detailed Demolition Plan	024116 – 1.3.2
	d) Dewatering Plan	033000 – 1.3.2
	e) Foundation Construction Plan	033000 – 1.3.3
	f) Drilling Plan	055000 – 1.3.2
28 calendar days after construction		011100 – 1.3.6
	As-built and QA/QC documents	033000 – 1.3.4
		055000 – 1.3.3
Upon request of Coast Guard	Completed Field Level Hazard Assessment (FLHA) forms	013530 – 1.3.3
	Product specifications and/or samples	016100 – 1.5
	Copies of certified receipts from the disposal sites	024116 – 1.3.4



Fisheries and Oceans
Canada

Pêches et Océans
Canada

Canadian
Coast Guard

Garde côtière
canadienne



APPENDIX C: DRAWINGS

CONCRETE & EPOXY

FORMS MAY EITHER BE KEPT DE-WATERED OR CONTAIN STANDING WATER DURING CONSTRUCTION, PROVIDED REQUIREMENTS FOR EACH CASE ARE MET AS FOLLOWS:

IF INSIDE OF FORM IS KEPT DE-WATERED AND DRY DURING PLACEMENT OF REINFORCING AND POURING OF CONCRETE, CONCRETE MAY BE POURED IN CONVENTIONAL MANNER (CHUTE). ENSURE DRILLED HOLES ARE FREE OF STANDING WATER WHEN EPOXYING THE VERTICAL REBAR.

IF INSIDE OF FORM IS NOT KEPT DEWATERED AND WILL HAVE STANDING WATER DURING PLACEMENT OF REINFORCING AND POURING OF CONCRETE, THEN A TEMPLATE FOR DRILLING THE HOLES FOR THE VERTICAL BARS SHALL BE USED. ALSO, THE CONCRETE SHALL BE PLACED USING THE TREMIE METHOD, AND THE MIX DESIGN TO HAVE ANTI-WASH ADDITIVE.

IN GENERAL, CONTRACTOR SHALL BE EXPERIENCED IN PLACING EPOXYED REBAR IN WET OR SUBMERGED CONDITIONS AS REQUIRED.

CONFORM TO CSA STANDARDS CAN3-A23.1-A23.3 AND THEIR SUPPLEMENTS.

TOLERANCES: CONFORM TO CSA STANDARD CAN3-A23.1

PORTLAND CEMENT WATER AND AGGREGATES TO CONFORM TO CSA A23.1 AND CAN3-A5.

AIR ENTRAINMENT ADMIXTURE: TO CSA STANDARD A266.1.

CHEMICAL ADMIXTURES: TO CSA STANDARD A266.2.

CURING/SEALING COMPOUND: TO ASTM C309.

ALL REINFORCING STEEL SHALL BE GRADE 400 MPa, CSA G30.18, EPOXY COATED.

INSTALL EPOXY ADHESIVE IN CONFORMANCE WITH MANUFACTURER'S INSTRUCTIONS. EPOXY ADHESIVE TO BE HILTI HIT-RE 500 V3.

USE VIBRATORS FOR PLACEMENT OF CONCRETE.

FOR READY-MIX CONCRETE THE MAXIMUM TIME PERMITTED BETWEEN CHARGING THE MIXER AND FINAL DEPOSIT IS 90 MINUTES. THERE IS NO TOLERANCE FOR ADDITIONAL TIME SPANS UNLESS A CONCRETE RETARDER IS USED.

EXPOSED CONCRETE SHALL BE FREE FROM HONEYCOMBING, VOIDS, LOSS OF FINES, VISIBLE FLOW LINES AND COLD JOINTS, CHIPS AND SPALLS.

PROTECT FRESH CONCRETE FROM PREMATURE DRYING, SUNSHINE, EXCESSIVELY HOT OR COLD TEMPERATURES AND MECHANICAL INJURY, MAINTAIN AT A RELATIVELY CONSTANT TEMPERATURE FOR AS LONG AS REQUIRED FOR HYDRATION OF THE CEMENT AND CURING OF THE CONCRETE.

SUPPLEMENTAL ADMIXTURES IMPACTING PLASTIC AND HARDENED PERFORMANCE SHALL BE SUBJECT TO APPROVAL OF COAST GUARD.

PLACEMENT OF REINFORCEMENT TO BE CONFIRMED BY COAST GUARD PRIOR TO CONCRETE PLACEMENT.

CONTRACTOR TO PROVIDE CONCRETE TESTING FOR 7 DAY AND 28 DAY COMPRESSIVE STRENGTH. ALSO PROVIDE TESTING FOR SLUMP AND AIR CONTENT. TESTING REPORTS TO BE SUBMITTED TO COAST GUARD FOR REVIEW.

TOWER SHALL NOT BE ERECTED UNTIL CONCRETE TESTING INDICATES AT LEAST 75% OF 28 DAY COMPRESSIVE STRENGTH

REFER TO COAST GUARD SPECIFICATIONS FOR FURTHER CONCRETE REQUIREMENTS

CLASS OF CONCRETE

PROVIDE NORMAL DENSITY CONCRETE TO ACHIEVE THE FOLLOWING PROPERTIES:

- CLASS OF EXPOSURE: C-1
- CEMENT TYPE: 10
- MINIMUM COMPRESSIVE STRENGTH: 5076psi (35MPa)
- MAXIMUM WATER CEMENT RATIO: 0.50
- AIR ENTRAINMENT: 5%-8%
- NOMINAL SIZE OF COURSE AGGREGATE: 3/4" (20MM)
- SLUMP AT 3" ±1" (75MM ±25MM)
- CURING REGIME TYPE: 2, (7 DAYS TOTAL AT >10°C)

SUBMITTALS

CONTRACTOR SHALL SUBMIT A SUMMARY OF CONCRETE PROPERTIES WITH CONSTRUCTION PLAN. SUBMIT TO COAST GUARD FOR REVIEW.

SUBMIT REBAR SHOP DRAWINGS FOR COAST GUARD REVIEW

FORMWORK AND FALSEWORK SHALL BE AS DETAILED IN APPROVED CONSTRUCTION PLAN. FOR DE-WATERED INSTALLATION, THE CONSTRUCTION PLAN SHALL SHOW ENGINEERED METHOD OF KEEPING WATER OUT OF THE FORM, EITHER WITH CAISSON AROUND FORM, OR USING THE FORM ITSELF.

CURING SHALL BE COMPLETED IN ACCORDANCE WITH APPROVED CONSTRUCTION PLAN

ANY ALTERNATE PRODUCTS OR PROCEDURES MUST BE APPROVED BY THE COAST GUARD

BEDROCK

VERTICAL REBAR SHALL BE EMBEDDED IN COMPETENT BEDROCK HAVING A MINIMUM COMPRESSIVE STRENGTH OF 5076 psi (35 MPa). SUITABILITY OF BEDROCK TO EITHER BE VERIFIED BY A GEOTECHNICAL ENGINEER, OR APPROVED BY COAST GUARD PERSONNEL.

DESIGN LOAD NOTES

TOWER WIND LOADS: WIND TOWER LOADS AS PROVIDED BY CANADIAN COAST GUARD, AND ARE SHOWN FACTORED

ICE LOADS: ICE LOADS HAVE BEEN DETERMINED IN ACCORDANCE WITH THE CANADIAN HIGHWAY BRIDGE DESIGN CODE CAN/CSA-S6.

TOTAL FACTORED LOADS: FOR TOTAL FACTORED DESIGN FORCES AND MOMENTS ON BASE OF PIER, SEE DWGS. s2.0 AND s3.0 AS APPLICABLE.

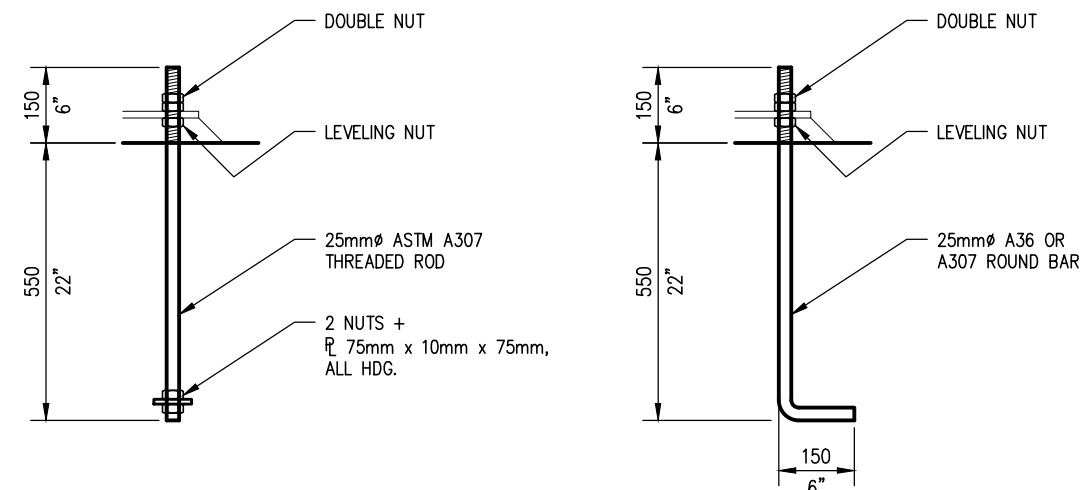
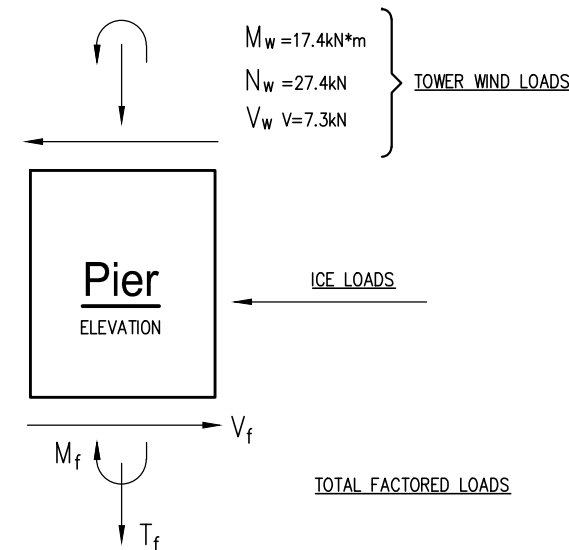

* ALL COMPONENTS HOT DIP GALVANIZED.

Typ. Anchor Bolt Detail

SCALE: 1:15

* ALL COMPONENTS HOT DIP GALVANIZED.

Alternate Anchor Bolt Detail

SCALE: 1:15

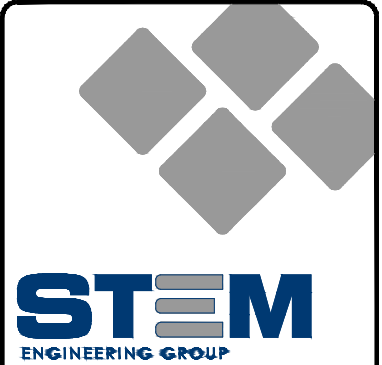

REVISIONS:		
NO.	DESCRIPTION	DATE

SEAL:



CLIENT:

FISHERIES AND OCEANS
CANADIAN COAST GUARD

PROJECT:

FOUNDATION FOR 16'-0"
PIPEMAST NAVIGATION
BEACONS

DRAWING:

GENERAL NOTES
DESIGN LOADS
ANCHOR BOLT DETAIL

SCALE: N.T.S.

PLOT SCALE: 1:1

STEM PROJ. NO: 17266

CAD FILE: 17266 s0.0

FORMAT SIZE: 280mmx432mm

DRAWN: TAB

DESIGNED: DMAC

CHECKED: DMAC

DATE: 18.03.26

DRAWING:

1 OF 4

s0.0

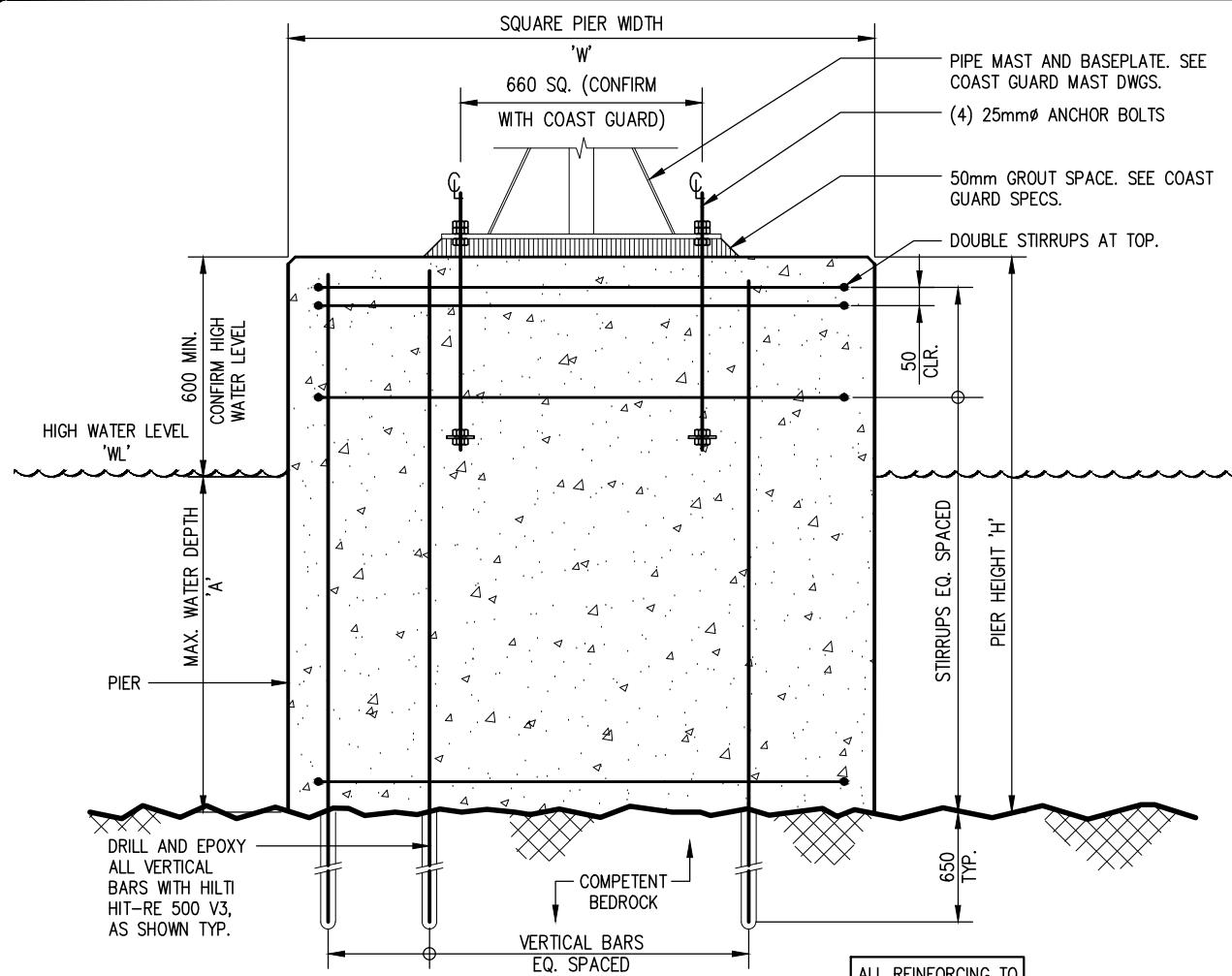

SECTION-VIEW (SQUARE PIER)

ALL REINFORCING TO BE EPOXY COATED

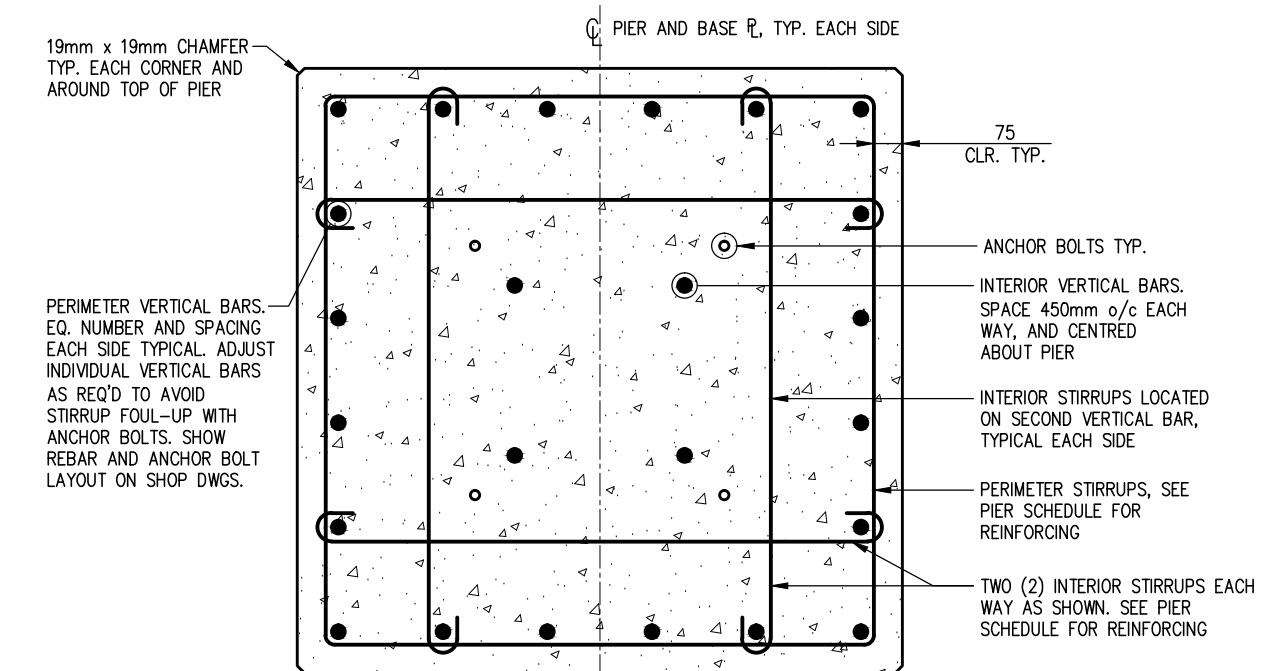

PLAN-VIEW (SQUARE PIER)

4.87m (16') PIPEMAST FOUNDATION PIER

SOUTHERN ONTARIO PIER SCHEDULE, SEE DWG. s2.0.
NORTHERN ONTARIO PIER SCHEDULE, SEE DWG. s3.0.

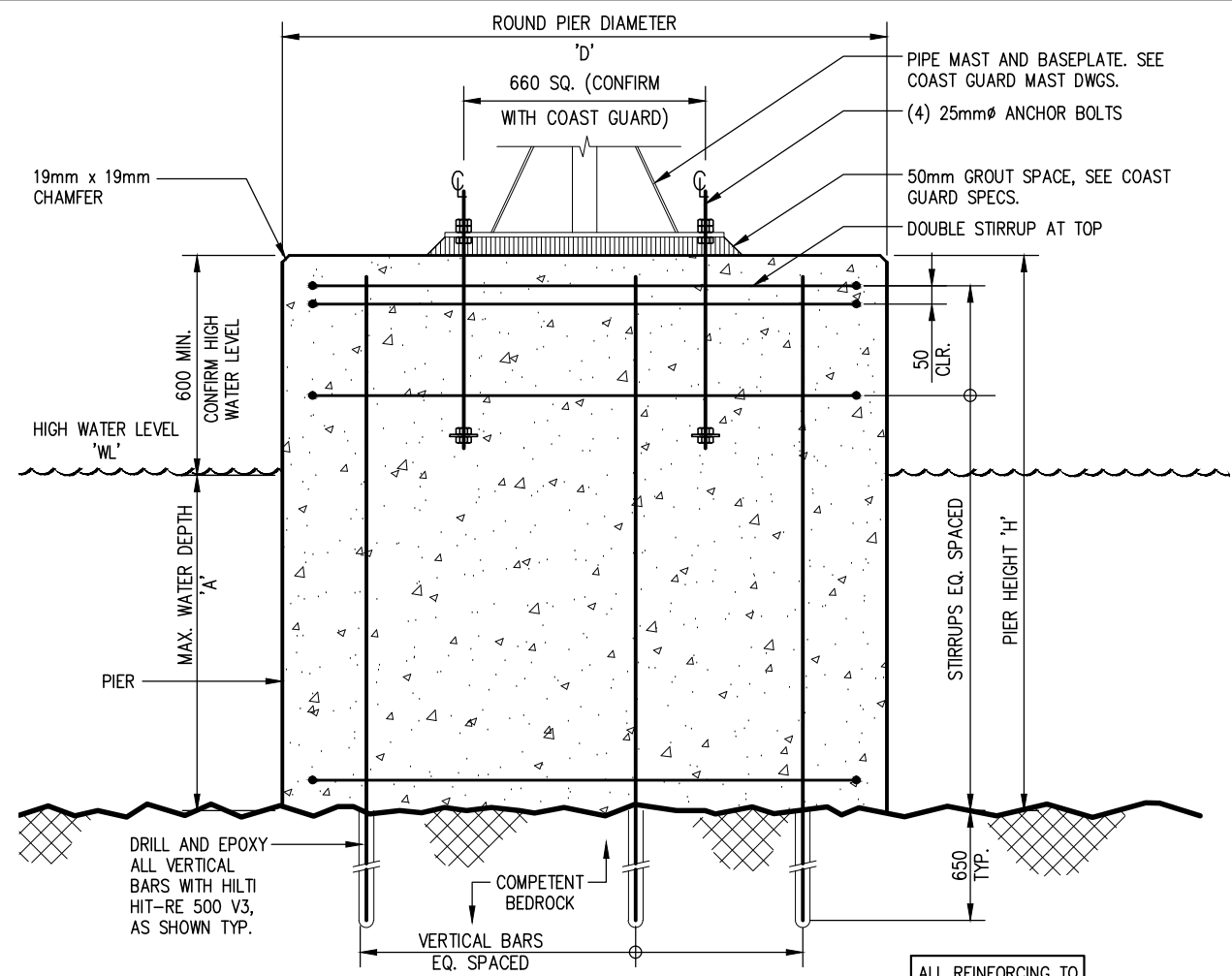

SECTION-VIEW (ROUND PIER)

ALL REINFORCING TO BE EPOXY COATED

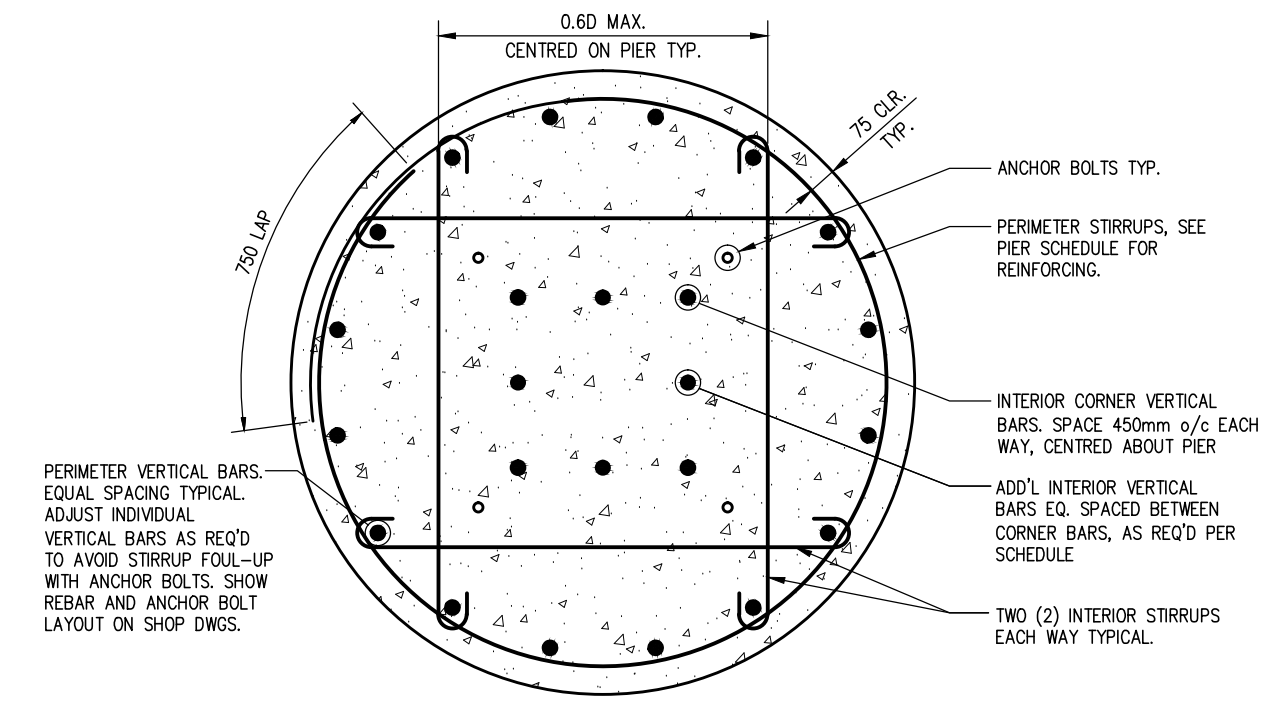

PLAN-VIEW (ROUND PIER)

4.87m (16') PIPEMAST FOUNDATION PIER

SOUTHERN ONTARIO PIER SCHEDULE, SEE DWG. s2.0.
NORTHERN ONTARIO PIER SCHEDULE, SEE DWG. s3.0.

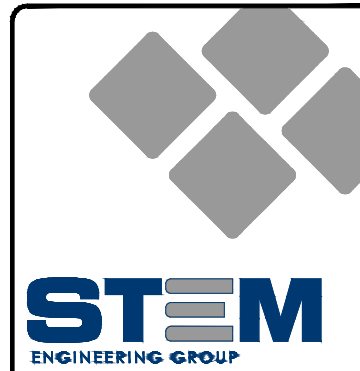

REVISIONS:

NO.	DESCRIPTION	DATE

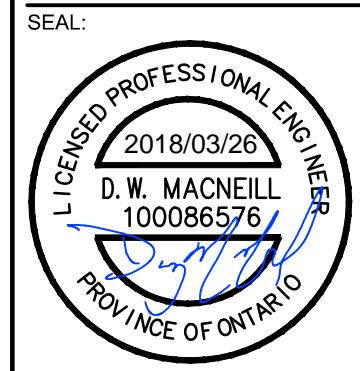

CLIENT:
FISHERIES AND OCEANS
CANADIAN COAST GUARD

PROJECT:
FOUNDATION FOR 16'-0"
PIPEMAST NAVIGATION
BEACONS

DRAWING:
SQUARE PIER DETAILS
ROUND PIER DETAILS

SCALE:	AS NOTED
PLOT SCALE:	1:1
STEM PROJ. NO:	17266
CAD FILE:	17266 s1.0
FORMAT SIZE:	280mmx432mm
DRAWN:	TAB
DESIGNED:	DMAC
CHECKED:	DMAC
DATE:	18.03.26

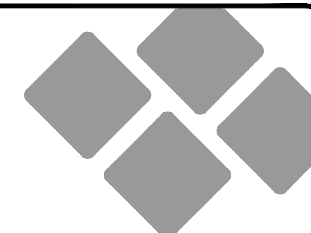

STEM
ENGINEERING GROUP

REVISIONS:		
NO.	DESCRIPTION	DATE

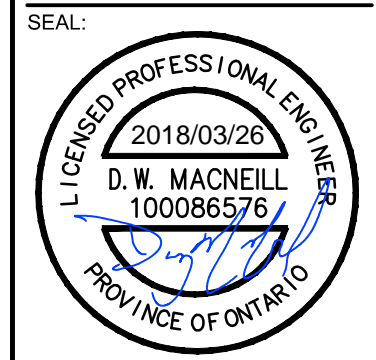

CLIENT:
FISHERIES AND OCEANS
CANADIAN COAST GUARD

PROJECT:
FOUNDATION FOR 16'-0"
PIPEMAST NAVIGATION
BEACONS

DRAWING:
PIER SCHEDULES
NORTHERN ONTARIO

SCALE: AS NOTED
PLOT SCALE: 1:1
STEM PROJ. NO: 17266
CAD FILE: 17266 s3.0
FORMAT SIZE: 280mmx432mm
DRAWN: TAB
DESIGNED: DMAC
CHECKED: DMAC
DATE: 18.03.26

DRAWING:
4 OF 4 **s3.0**

Square Pier: 'Northern Ontario' Classification: North of Ottawa and Extends to Kenora & Big Woods Lake as the Limit



Freezing Index 3000 F° Deg. Days

Pier Geometry			Pier Reinforcing				Total Factored Ice & Wind Forces on Base of Pier (S6-06 Bridge Code)			
Water Depth 'A' (m)	Pier Height 'H' (m)	Square Pier Width 'W' (m)	Perimeter Vertical Bars Total	Interior Vertical Bars Total	Perimeter Stirrups Typical	Interior Stirrups Typical	Design Ice thickness (mm)	Vf (kN)	Mf (kN-m)	Tf (kN)
0.000	0.600	1.050	8-25M's	0	15M's @300	0	0	9	22	-43
0.305	0.905	1.050	12-25M's	0	15M's @300	0	305	630	114	139
0.610	1.210	1.200	16-30M's	4-30M's	15M's @300	0	610	1433	456	651
0.915	1.515	1.500	20-35M's	4-35M's	15M's @300	15M's @300	832	2438	1237	1233
1.220	1.820	1.800	24-35M's	4-35M's	15M's @300	15M's @300	832	2924	2373	1220
1.525	2.125	1.900	28-35M's	4-35M's	15M's @300	15M's @300	832	3086	3447	1202
1.830	2.430	2.000	32-35M's	4-35M's	15M's @300	15M's @300	832	3248	4619	1180

Round Pier: 'Northern Ontario' Classification: North of Ottawa and Extends to Kenora & Big Woods Lake as the Limit



Freezing Index 3000 F° Deg. Days

Pier Geometry			Pier Reinforcing				Total Factored Ice & Wind Forces on Base of Pier (S6-06 Bridge Code)			
Water Depth 'A' (m)	Pier Height 'H' (m)	Round Pier Diameter 'D' (m)	Perimeter Vertical Bars Total	Interior Vertical Bars Total	Perimeter Stirrups Typical	Interior Stirrups Typical	Design Ice thickness (mm)	Vf (kN)	Mf (kN-m)	Tf (kN)
0.000	0.600	1.350	8-25M's	0	15M's @300	0	0	9	22	-48
0.305	0.905	1.350	12-25M's	0	15M's @300	0	305	620	113	137
0.610	1.210	1.350	12-30M's	4-30M's	15M's @300	15M's @300	610	1235	396	651
0.915	1.515	1.650	16-35M's	4-35M's	15M's @300	15M's @300	832	2055	1046	1232
1.220	1.820	1.800	20-35M's	4-35M's	15M's @300	15M's @300	832	2241	1824	1223
1.525	2.125	2.000	24-35M's	6-35M's	15M's @300	15M's @300	832	2490	2785	1207
1.830	2.430	2.000	24-35M's	8-35M's	15M's @300	15M's @300	832	2490	3546	1193

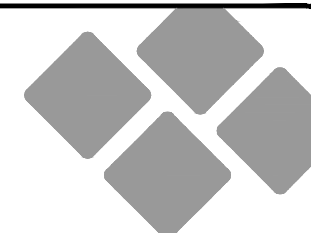

STEM
ENGINEERING GROUP

REVISIONS:

NO.	DESCRIPTION	DATE

SEAL:

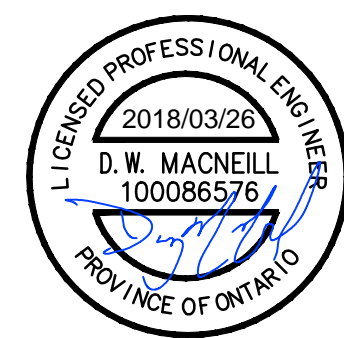

CLIENT:
FISHERIES AND OCEANS
CANADIAN COAST GUARD

PROJECT:
FOUNDATION FOR 16'-0"
PIPEMAST NAVIGATION
BEACONS

DRAWING:
PIER SCHEDULES
SOUTHERN ONTARIO

SCALE: AS NOTED
PLOT SCALE: 1:1
STEM PROJ. NO: 17266
CAD FILE: 17266 s2.0
FORMAT SIZE: 280mmx432mm
DRAWN: TAB
DESIGNED: DMAC
CHECKED: DMAC
DATE: 18.03.26

DRAWING:
3 OF 4 **s2.0**

Square Pier: 'Southern Ontario' Classification: Ottawa & Huntsville Inclusive and All Areas Extending Southwards

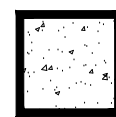

Freezing Index 1800 F° Deg. Days

Pier Geometry			Pier Reinforcing				Total Factored Ice & Wind Forces on Base of Pier (S6-06 Bridge Code)			
Water Depth 'A' (m)	Pier Height 'H' (m)	Square Pier Width 'W' (m)	Perimeter Vertical Bars Total	Interior Vertical Bars Total	Perimeter Stirrups Typical	Interior Stirrups Typical	Design Ice thickness (mm)	Vf (kN)	Mf (kN-m)	Tf (kN)
0.000	0.600	1.050	8-25M's	0	15M's @300	0	0	9	22	-43
0.305	0.905	1.050	12-25M's	0	15M's @300	0	305	630	114	139
0.610	1.210	1.200	16-30M's	0	15M's @300	0	610	1433	456	651
0.915	1.515	1.200	12-35M's	4-35M's	15M's @300	0	644	1512	917	724
1.220	1.820	1.400	16-35M's	4-35M's	15M's @300	0	644	1764	1606	715
1.525	2.125	1.600	20-35M's	4-35M's	15M's @300	15M's @300	644	2015	2447	698
1.830	2.430	1.800	24-35M's	4-35M's	15M's @300	15M's @300	644	2266	3442	674

Round Pier: 'Southern Ontario' Classification: Ottawa & Huntsville Inclusive and All Areas Extending Southwards



Freezing Index 1800 F° Deg. Days

Pier Geometry			Pier Reinforcing				Total Factored Ice & Wind Forces on Base of Pier (S6-06 Bridge Code)			
Water Depth 'A' (m)	Pier Height 'H' (m)	Round Pier Diameter 'D' (m)	Perimeter Vertical Bars Total	Interior Vertical Bars Total	Perimeter Stirrups Typical	Interior Stirrups Typical	Design Ice thickness (mm)	Vf (kN)	Mf (kN-m)	Tf (kN)
0.000	0.600	1.350	8-25M's	0	15M's @300	0	0	9	22	-48
0.305	0.905	1.350	12-25M's	0	15M's @300	0	305	620	113	137
0.610	1.210	1.350	12-30M's	4-30M's	15M's @300	15M's @300	610	1235	396	651
0.915	1.515	1.500	12-35M's	4-35M's	15M's @300	15M's @300	644	1449	879	724
1.220	1.820	1.500	16-35M's	4-35M's	15M's @300	15M's @300	644	1449	1323	716
1.525	2.125	1.650	18-35M's	4-35M's	15M's @300	15M's @300	644	1593	1940	704
1.830	2.430	1.800	20-35M's	4-35M's	15M's @300	15M's @300	644	1737	2645	688

inches

millimètres

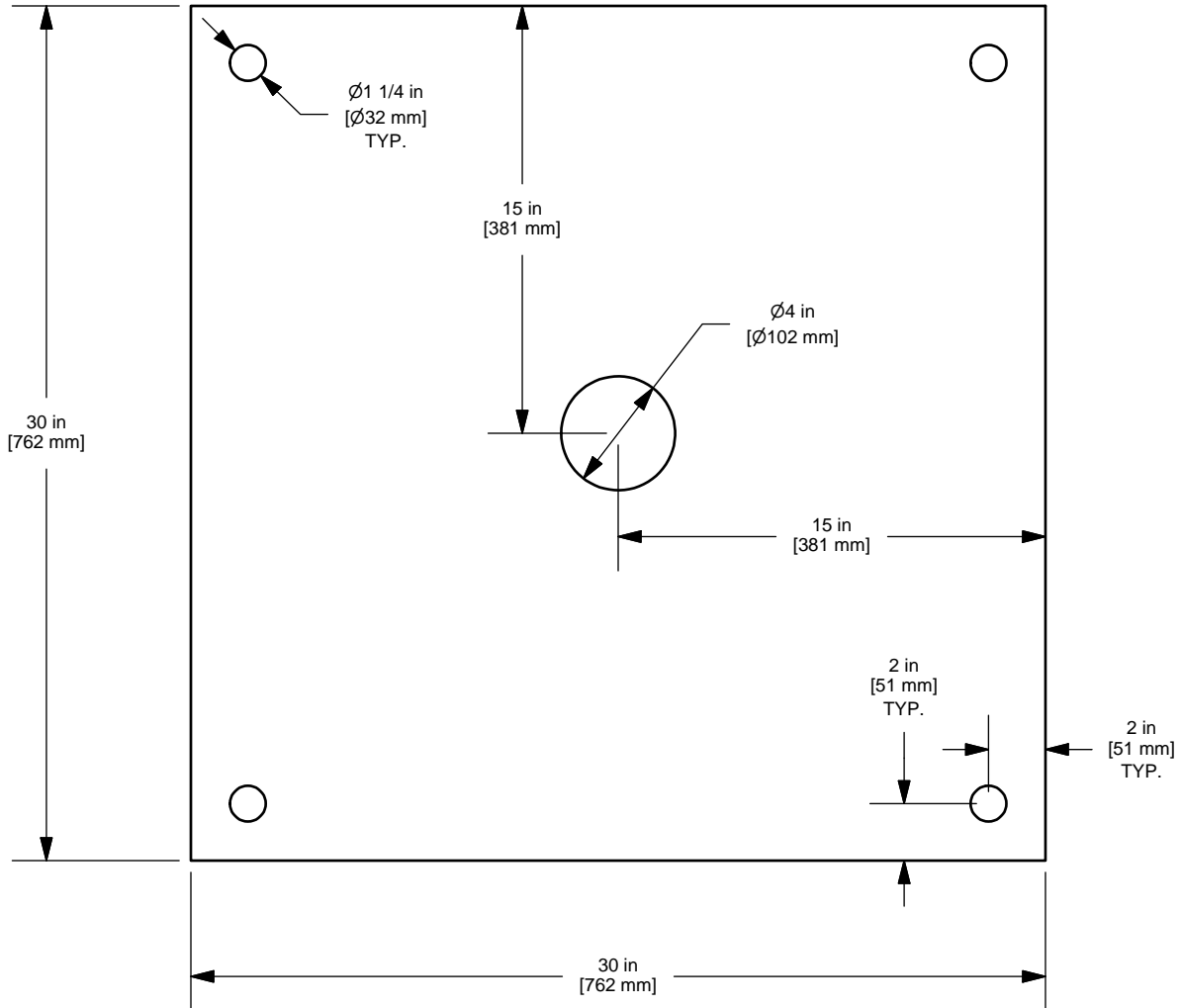
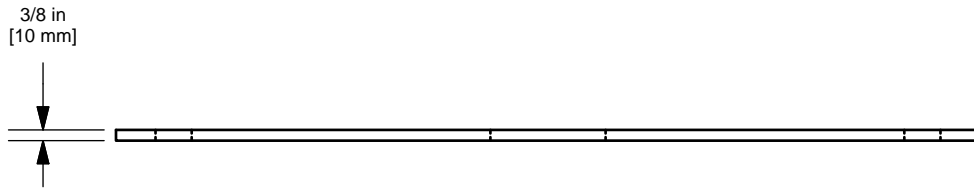

	Fisheries and Oceans Canada	Pêches et Océans Canada
	Canadian Coast Guard	Garde côtière Canadienne
CCG ref. no. - no. réf. GCC EWTM-8010-6	scale - échelle AS SHOWN	

Asset - Actif	12', 16', AND 20' PIPEMASTS		designed - conception BH	date 2017-12-11
Drawing - Dessin	P5 - BASE PLATE		approved - approuvé BY	date 2017-12-11
			drawing no. - no. dessin EWTM-8010-6	sheet-feuille 10/25
			rev 0	A

designed - conception BH	date 2017-12-11
approved - approuvé BY	date 2017-12-11
drawing no. - no. dessin EWTM-8010-6	sheet-feuille 10/25
rev 0	A

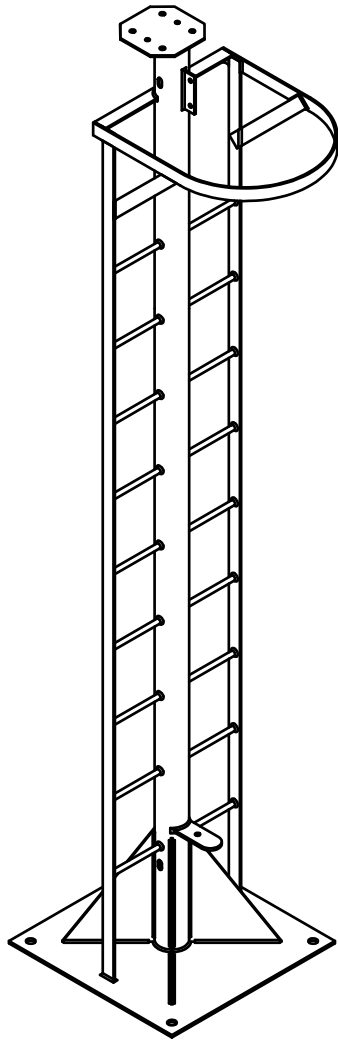

12' PIPEMAST

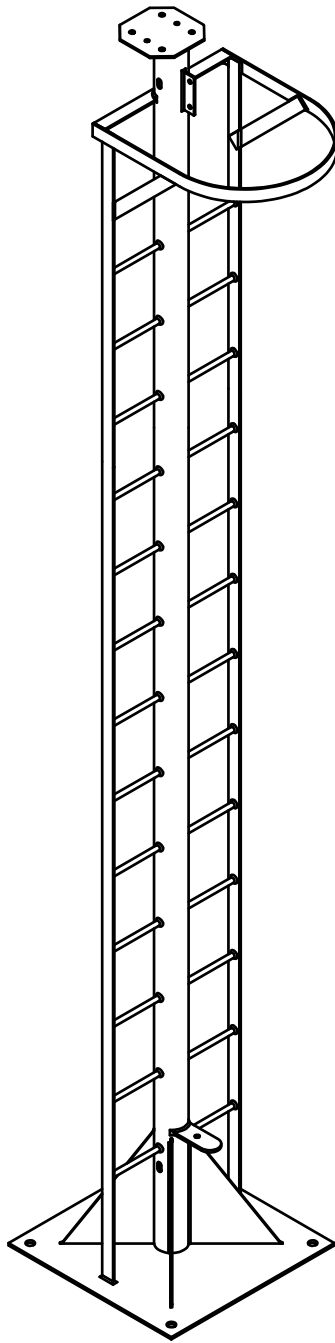

16' PIPEMAST

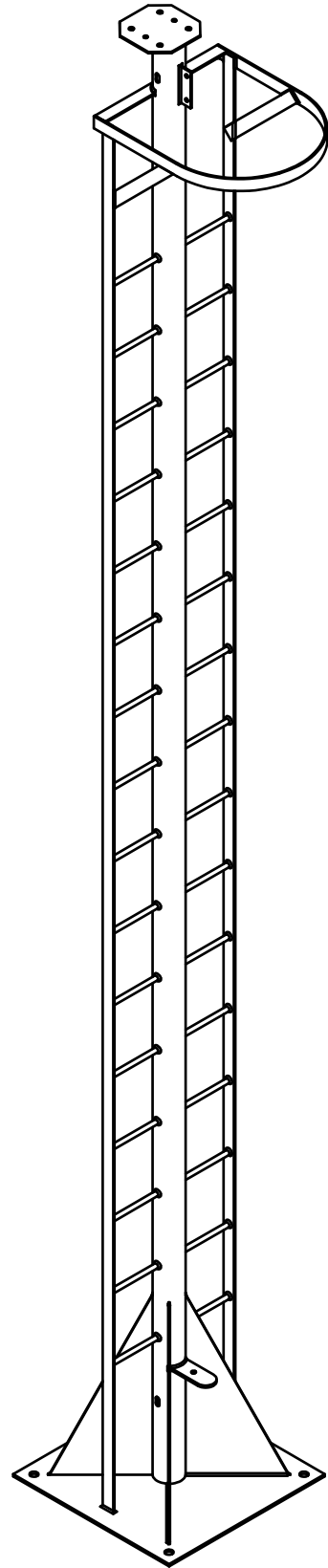

20' PIPEMAST

inches 0 1 2 3 4

millimeters 0 1 2 3 4 5 6 7 8

 Fisheries and Oceans Canada Canadian Coast Guard	Pêches et Océans Canada Garde côtière Canadienne

Asset - Actif	12', 16', AND 20' PIPEMASTS		designed - conception	date
Drawing - Dessin			BH	2017-12-11
	approved - approuvé	date		
	BY	2017-12-11		
	drawing no. - no. dessin	sheet-feuille	rev	
	EWTM-8010-6	1/25	0	

File / Fichier: 12', 16' and 20' Pipemasts.dwg

inches
0
1
2
3
4
pouces

millimeters
0
1
2
3
4
5
6
7
8
millimètres

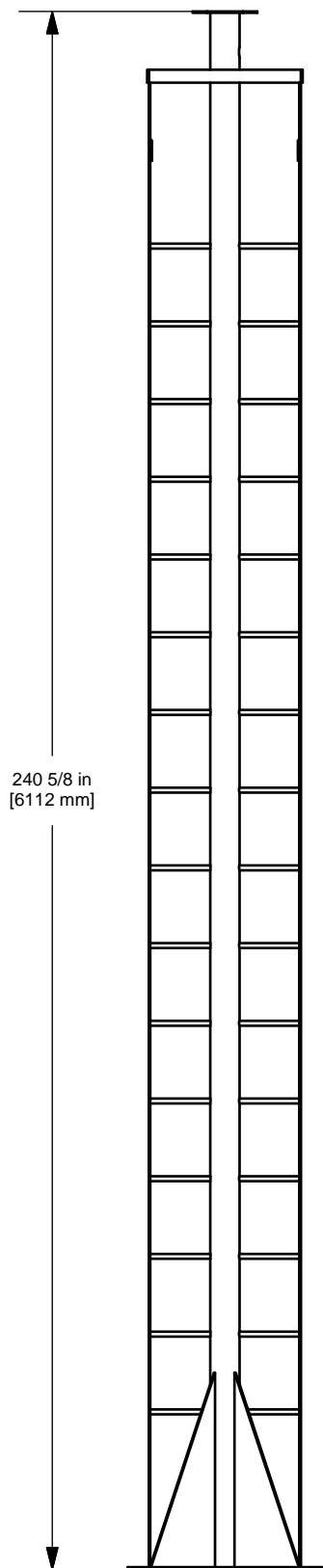
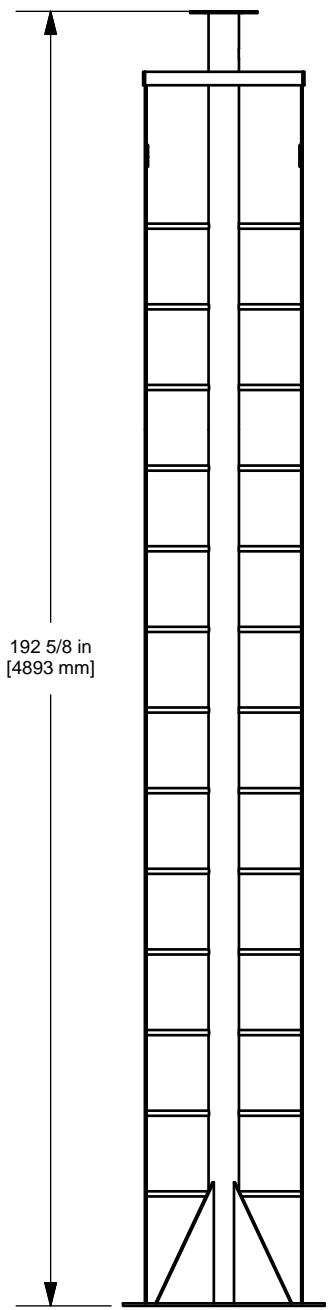
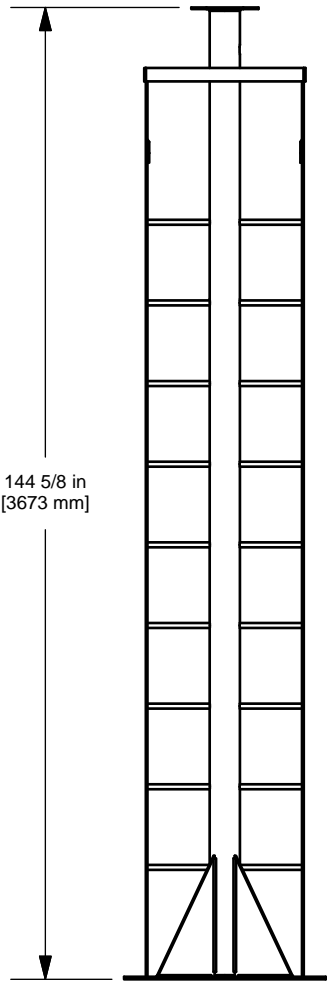

<p>Fisheries and Oceans Canada Canadian Coast Guard</p>	<p>Pêches et Océans Canada Garde côtière Canadienne</p>

Asset - Actif	<h3>12', 16', AND 20' PIPEMASTS</h3>	
Drawing - Dessin		
<h4>PIPEMAST SIZES</h4>		

designed - conception	date
BH	2017-12-11
approved - approuvé	date
BY	2017-12-11
drawing no. - no. dessin	sheet-feuille
EWTM-8010-6	2/25
	rev
	0



Fisheries and Oceans
Canada

Pêches et Océans
Canada

Canadian
Coast Guard

Garde côtière
canadienne



APPENDIX D: MARINE ACCESS REQUIREMENTS

.1 Marine Access

- .1 Vessel(s) employed in the performance of the contract shall be certified as required by the Canada Shipping Act 2001 and its applicable regulations including Marine Personnel Regulation.
 - .1 The bidder shall ensure that the vessel(s) proposed for the work meets all requirements of the Canada Shipping Act 2001 and the applicable Regulations under the Canada Shipping Act.
 - .2 Bidders shall provide copies of the following documentation to facilitate evaluation and award:
 - .1 Proof of vessel registration as a commercial vessel in accordance with the Canada Shipping Act 2001. Either one of two registrations will be accepted:
 - .1 Proof of commercial vessel registration in the Small Vessel Register (SVR) if less than 15 Gross Tons or;
 - .2 Proof of commercial vessel registration in the Canadian Register of Vessels (CRV) if more than 15 Gross Tons.
 - .3 NOTE: Pleasure Craft and Fishing Vessels are not acceptable for the performance of this work – it must be a commercially registered vessel.
 - .2 Where the vessel is registered in the SVR the bidder shall also provide the following:
 - .1 Copy of vessel certification and any limitations the vessel is operating under. Where the vessel is restricted, the operator shall ensure that the vessel can be used to safely perform the work in this specification;
 - .2 Copy of inspection according to the Small Vessel Compliance Program; Bidder shall submit proof of enrolment in the compliance program and;
 - .3 Either a copy of the initial inspection report or the most recent copy of an annual inspection report and;
 - .4 Copy of the crew certification that will be operating the vessel. Crewing and certification of crew shall be in accordance with the Marine Personnel Regulations, latest edition.
 - .3 Where the vessel is registered in the CRV the bidder shall also provide the following:
 - .1 Copy of the latest Annual Inspection Certificate endorsement and;

- .2 Copy of any restrictions that the vessel is operating under and the general sailing limitations of the vessel. Where the vessel is restricted, the operator shall ensure that the vessel can be used to safely perform the work in this specification;
 - .3 Copies of the crew certification that will be operating the vessel. Crewing and certification of crew shall be in accordance with the Marine Personnel Regulations, latest edition.
- .2 Vessels and crew found to be in contravention of the act will not be permitted to be engaged in any elements of the works identified herein. In the event that a vessel or crew is found non compliant a suitable replacement vessel and/or crew will be retained by the Contractor at their sole expense.



Fisheries and Oceans
Canada

Pêches et Océans
Canada

Canadian
Coast Guard

Garde côtière
canadienne



APPENDIX E: MANDATORY CRITERIA

Mandatory Technical Criteria				
Item	Criteria	Compliant		
		Yes	No	N/A
1	<p>Each vessel used by the bidder for this contract must be registered in Canada in the Small Vessel Register (SVR) or the Canadian Register of Vessels (CRV).</p> <p>Proof of registration as well as a picture of the vessel with its Official Number visible shall be submitted with bid.</p>			

Reference

Small
Commercial
Vessel Safety
Guide - p. 29

Company Name: _____

Signature: _____

Date: _____