



**RETURN BIDS TO:
RETOURNER LES SOUMISSIONS À:**

Veterans Affairs Canada
Procurement & Contracting –
Attn: Monique Mader
monique.mader@canada.ca

REQUEST FOR PROPOSAL

DEMANDE DE PROPOSITION

Proposal To: Veterans Affairs Canada

We hereby offer to sell to Her Majesty the Queen in right of Canada, in accordance with the terms and conditions set out herein, referred to herein or attached hereto, the goods, services, and construction listed herein and on any attached sheets at the price(s) set out thereof.

Proposition aux: Anciens Combattants Canada

Nous offrons par la présente de vendre à Sa Majesté la Reine du chef du Canada, aux conditions énoncées ou incluses par référence dans la présente et aux annexes ci-jointes, les biens, services et construction énumérés ici sur toute feuille ci-annexées, au(x) prix indiqué(s)

Comments - Commentaires

Vendor/Firm Name and address
Raison sociale et adresse du fournisseur/de l'entrepreneur

Issuing Office – Bureau de distribution

Veterans Affairs Canada
Procurement & Contracting
Charlottetown, PEI
Canada

Title – Sujet Cemetery Maintenance-Halifax	
Solicitation No. – N° de l'invitation 0X180801384501P	Date 2018-08-16
GETS Reference No. – N° de reference de SEAG -	
File No. – N° de dossier	CCC No. / N° CCC - FMS No. / N° VME
Solicitation Closes – L'invitation prend fin at – à 02 :00 PM on – le (2018-09-06)	
Time Zone Fuseau horaire Atlantic Standard Time ADT	
F.O.B. - F.A.B. <i>Plant-Usine:</i> <input type="checkbox"/> <i>Destination:</i> <input type="checkbox"/> <i>Other-Autre:</i> <input type="checkbox"/>	
Address Inquiries to : - Adresser toutes questions à: Monique Mader	Buyer Id – Id de l'acheteur
Telephone No. – N° de téléphone : (902) 626-2771	FAX No. – N° de FAX N/A
Destination – of Goods, Services, and Construction: Destination – des biens, services et construction : Various Cemeteries in the Halifax region	

Instructions: See Herein
Instructions : Voir aux présentes

Delivery required - Livraison exigée See Herein	Delivered Offered – Livraison proposée
Vendor/firm Name and address Raison sociale et adresse du fournisseur/de l'entrepreneur	
Facsimile No. – N° de télécopieur Telephone No. – N° de téléphone	
Name and title of person authorized to sign on behalf of Vendor/firm (type or print)- Nom et titre de la personne autorisée à signer au nom du fournisseur/de l'entrepreneur (taper ou écrire en caractères d'imprimerie)	
Signature	Date _____

TABLE OF CONTENTS

PART 1 - GENERAL INFORMATION 3

1.1 SECURITY REQUIREMENTS 3

1.2 STATEMENT OF WORK..... 3

1.5 DEBRIEFINGS..... 3

1.7 TRADE AGREEMENTS 3

PART 2 - BIDDER INSTRUCTIONS 3

2.1 STANDARD INSTRUCTIONS, CLAUSES AND CONDITIONS..... 3

2.2 SUBMISSION OF BIDS..... 3

2.3 FORMER PUBLIC SERVANT..... 4

2.4 ENQUIRIES - BID SOLICITATION..... 5

2.5 APPLICABLE LAWS..... 5

PART 3 - BID PREPARATION INSTRUCTIONS..... 5

3.1 BID PREPARATION INSTRUCTIONS 5

PART 4 - EVALUATION PROCEDURES AND BASIS OF SELECTION 6

4.1 EVALUATION PROCEDURES..... 6

4.2 BASIS OF SELECTION..... 7

PART 5 – CERTIFICATIONS AND ADDITIONAL INFORMATION 7

5.1 CERTIFICATIONS REQUIRED WITH THE BID..... 7

5.2 CERTIFICATIONS PRECEDENT TO CONTRACT AWARD AND ADDITIONAL INFORMATION 7

PART 6 - RESULTING CONTRACT CLAUSES 8

6.1 SECURITY REQUIREMENTS 8

6.2 STATEMENT OF WORK..... 8

6.3 STANDARD CLAUSES AND CONDITIONS..... 8

6.4 TERM OF CONTRACT 8

6.5 AUTHORITIES 8

6.6 PROACTIVE DISCLOSURE OF CONTRACTS WITH FORMER PUBLIC SERVANTS 9

6.7 PAYMENT 9

6.8 INVOICING INSTRUCTIONS 10

6.9 CERTIFICATIONS AND ADDITIONAL INFORMATION..... 10

6.10 APPLICABLE LAWS..... 10

6.11 PRIORITY OF DOCUMENTS 10

6.13 SACC MANUAL CLAUSES..... 11

ANNEX "A"..... 12

STATEMENT OF WORK 12

51019-13-1003

PART 1 - GENERAL INFORMATION

1.1 Security Requirements

There is no security requirement applicable to the Contract.

1.2 Statement of Work

The Work to be performed is detailed under Article 6.2 of the resulting contract clauses.

1.3 Debriefings

Bidders may request a debriefing on the results of the bid solicitation process. Bidders should make the request to the Contracting Authority within 15 working days from receipt of the results of the bid solicitation process. The debriefing may be in writing, by telephone or in person.

1.74 Trade Agreements

The requirement is subject to the provisions of the Canadian Free Trade Agreement (CFTA).

PART 2 - BIDDER INSTRUCTIONS

2.1 Standard Instructions, Clauses and Conditions

All instructions, clauses and conditions identified in the bid solicitation by number, date and title are set out in the [Standard Acquisition Clauses and Conditions Manual](https://buyandsell.gc.ca/policy-and-guidelines/standard-acquisition-clauses-and-conditions-manual) (https://buyandsell.gc.ca/policy-and-guidelines/standard-acquisition-clauses-and-conditions-manual) issued by Public Works and Government Services Canada.

Bidders who submit a bid agree to be bound by the instructions, clauses and conditions of the bid solicitation and accept the clauses and conditions of the resulting contract.

The [2003](#) (2018-05-22) Standard Instructions - Goods or Services - Competitive Requirements, are incorporated by reference into and form part of the bid solicitation.

Subsection 5.4 of [2003](#), Standard Instructions - Goods or Services - Competitive Requirements, is amended as follows:

Delete: 60 days

Insert: 90 days

2.2 Submission of Bids

Bids must be submitted only to Monique Mader by the date, time and email address indicated on the cover page of the bid solicitation.

Due to the nature of the bid solicitation, bids submitted by facsimile, mail, or courier service will not be accepted.

2.3 Former Public Servant

Contracts awarded to former public servants (FPS) in receipt of a pension or of a lump sum payment must bear the closest public scrutiny, and reflect fairness in the spending of public funds. In order to comply with Treasury Board policies and directives on contracts awarded to FPSs, bidders must provide the information required below before contract award. If the answer to the questions and, as applicable the information required have not been received by the time the evaluation of bids is completed, Canada will inform the Bidder of a time frame within which to provide the information. Failure to comply with Canada's request and meet the requirement within the prescribed time frame will render the bid non-responsive.

Definitions

For the purposes of this clause, "former public servant" is any former member of a department as defined in the [Financial Administration Act](#), R.S., 1985, c. F-11, a former member of the Canadian Armed Forces or a former member of the Royal Canadian Mounted Police. A former public servant may be:

- a. an individual;
- b. an individual who has incorporated;
- c. a partnership made of former public servants; or
- d. a sole proprietorship or entity where the affected individual has a controlling or major interest in the entity.

"lump sum payment period" means the period measured in weeks of salary, for which payment has been made to facilitate the transition to retirement or to other employment as a result of the implementation of various programs to reduce the size of the Public Service. The lump sum payment period does not include the period of severance pay, which is measured in a like manner.

"pension" means a pension or annual allowance paid under the [Public Service Superannuation Act](#) (PSSA), R.S., 1985, c. P-36, and any increases paid pursuant to the [Supplementary Retirement Benefits Act](#), R.S., 1985, c. S-24 as it affects the PSSA. It does not include pensions payable pursuant to the [Canadian Forces Superannuation Act](#), R.S., 1985, c. C-17, the [Defence Services Pension Continuation Act](#), 1970, c. D-3, the [Royal Canadian Mounted Police Pension Continuation Act](#), 1970, c. R-10, and the [Royal Canadian Mounted Police Superannuation Act](#), R.S., 1985, c. R-11, the [Members of Parliament Retiring Allowances Act](#), R.S. 1985, c. M-5, and that portion of pension payable to the [Canada Pension Plan Act](#), R.S., 1985, c. C-8.

Former Public Servant in Receipt of a Pension

As per the above definitions, is the Bidder a FPS in receipt of a pension? **Yes () No ()**

If so, the Bidder must provide the following information, for all FPSs in receipt of a pension, as applicable:

- a. name of former public servant;
- b. date of termination of employment or retirement from the Public Service.

By providing this information, Bidders agree that the successful Bidder's status, with respect to being a former public servant in receipt of a pension, will be reported on departmental websites as part of the published proactive disclosure reports in accordance with [Contracting Policy Notice: 2012-2](#) and the [Guidelines on the Proactive Disclosure of Contracts](#).

Work Force Adjustment Directive

Is the Bidder a FPS who received a lump sum payment pursuant to the terms of the Work Force Adjustment Directive? **Yes () No ()**

If so, the Bidder must provide the following information:

- a. name of former public servant;
- b. conditions of the lump sum payment incentive;
- c. date of termination of employment;
- d. amount of lump sum payment;
- e. rate of pay on which lump sum payment is based;
- f. period of lump sum payment including start date, end date and number of weeks;
- g. number and amount (professional fees) of other contracts subject to the restrictions of a work force adjustment program.

For all contracts awarded during the lump sum payment period, the total amount of fees that may be paid to a FPS who received a lump sum payment is \$5,000, including Applicable Taxes.

2.4 Enquiries - Bid Solicitation

All enquiries must be submitted in writing to the Contracting Authority no later than 5 calendar days before the bid closing date. Enquiries received after that time may not be answered.

Bidders should reference as accurately as possible the numbered item of the bid solicitation to which the enquiry relates. Care should be taken by Bidders to explain each question in sufficient detail in order to enable Canada to provide an accurate answer. Technical enquiries that are of a proprietary nature must be clearly marked "proprietary" at each relevant item. Items identified as "proprietary" will be treated as such except where Canada determines that the enquiry is not of a proprietary nature. Canada may edit the question(s) or may request that the Bidder do so, so that the proprietary nature of the question(s) is eliminated, and the enquiry can be answered to all Bidders. Enquiries not submitted in a form that can be distributed to all Bidders may not be answered by Canada.

2.5 Applicable Laws

Any resulting contract must be interpreted and governed, and the relations between the parties determined, by the laws in force in Prince Edward Island.

Bidders may, at their discretion, substitute the applicable laws of a Canadian province or territory of their choice without affecting the validity of their bid, by deleting the name of the Canadian province or territory specified and inserting the name of the Canadian province or territory of their choice. If no change is made, it acknowledges that the applicable laws specified are acceptable to the Bidders.

PART 3 - BID PREPARATION INSTRUCTIONS

3.1 Bid Preparation Instructions

Bidders must submit bids via email.

The bid must be gathered per section and separated as follows:

- Section I: Technical Bid
- Section II: Financial Bid
- Section III: Certifications

Due to the nature of the bid solicitation, bids transmitted by facsimile, mail, or courier service will not be accepted.

Prices must appear in the financial bid only. No prices must be indicated in any other section of the bid.

Canada requests that bidders follow the format instructions described below in the preparation of hard copy of their bid:

- (a) use 8.5 x 11 inch (216 mm x 279 mm) paper;
- (b) use a numbering system that corresponds to the bid solicitation.

In April 2006, Canada issued a policy directing federal departments and agencies to take the necessary steps to incorporate environmental considerations into the procurement process [Policy on Green Procurement](https://www.tbs-sct.gc.ca/pol/doc-eng.aspx?id=32573) (https://www.tbs-sct.gc.ca/pol/doc-eng.aspx?id=32573). To assist Canada in reaching its objectives, bidders should:

- 1) use 8.5 x 11 inch (216 mm x 279 mm) paper containing fibre certified as originating from a sustainably-managed forest and containing minimum 30% recycled content; and
- 2) use an environmentally-preferable format including black and white printing instead of colour printing, printing double sided/duplex, using staples or clips instead of cerlox, duotangs or binders.

Section I: Technical Bid

In their technical bid, Bidders should explain and demonstrate how they propose to meet the requirements and how they will carry out the Work.

Section II: Financial Bid

Bidders must submit their financial bid in accordance with the Basis of Payment.

C3011T (2014-11-27), Exchange Rate Fluctuation

Section III: Certifications

Bidders must submit the certifications and additional information required under Part 5.

PART 4 - EVALUATION PROCEDURES AND BASIS OF SELECTION

4.1 Evaluation Procedures

- (a) Bids will be assessed in accordance with the entire requirement of the bid solicitation including the technical and financial evaluation criteria.
- (b) An evaluation team composed of representatives of Canada will evaluate the bids.

4.1.1 Technical Evaluation

4.1.1.1 Mandatory Technical Criteria

Offerors must demonstrate that they meet all the criteria set out in Annex "A" Statement of Work & Specifications. Failure to do so will deem bid non-responsive.

- All mandatory criteria set out in the Statement of Work & Specifications at Annex "A" is read, understood and met:

Yes_____ No_____

4.1.2 Financial Evaluation

SACC Manual Clause A0220T (2014-06-26), Evaluation of Price

4.2 Basis of Selection

A bid must comply with all requirements of the bid solicitation to be declared responsive. The responsive bid with the lowest evaluated price will be recommended for award of a contract.

PART 5 – CERTIFICATIONS AND ADDITIONAL INFORMATION

Bidders must provide the required certifications and additional information to be awarded a contract.

The certifications provided by Bidders to Canada are subject to verification by Canada at all times. Unless specified otherwise, Canada will declare a bid non-responsive, or will declare a contractor in default if any certification made by the Bidder is found to be untrue whether made knowingly or unknowingly, during the bid evaluation period or during the contract period.

The Contracting Authority will have the right to ask for additional information to verify the Bidder's certifications. Failure to comply and to cooperate with any request or requirement imposed by the Contracting Authority will render the bid non-responsive or constitute a default under the Contract.

5.1 Certifications Required with the Bid

Bidders must submit the following duly completed certifications as part of their bid.

5.1.1 Integrity Provisions - Declaration of Convicted Offences

In accordance with the Integrity Provisions of the Standard Instructions, all bidders must provide with their bid, **if applicable**, the declaration form available on the [Forms for the Integrity Regime](http://www.tpsgc-pwgsc.gc.ca/ci-if/declaration-eng.html) website (<http://www.tpsgc-pwgsc.gc.ca/ci-if/declaration-eng.html>), to be given further consideration in the procurement process.

5.2 Certifications Precedent to Contract Award and Additional Information

The certifications and additional information listed below should be submitted with the bid, but may be submitted afterwards. If any of these required certifications or additional information is not completed and submitted as requested, the Contracting Authority will inform the Bidder of a time frame within which to provide the information. Failure to provide the certifications or the additional information listed below within the time frame provided will render the bid non-responsive.

5.2.1 Integrity Provisions – Required Documentation

In accordance with the section titled Information to be provided when bidding, contracting or entering into a real procurement agreement of the [Ineligibility and Suspension Policy](http://www.tpsgc-pwgsc.gc.ca/ci-if/politique-policy-eng.html) (<http://www.tpsgc-pwgsc.gc.ca/ci-if/politique-policy-eng.html>), the Bidder must provide the required documentation, as applicable, to be given further consideration in the procurement process.

5.2.2 Federal Contractors Program for Employment Equity - Bid Certification

By submitting a bid, the Bidder certifies that the Bidder, and any of the Bidder's members if the Bidder is a Joint Venture, is not named on the Federal Contractors Program (FCP) for employment equity "FCP Limited Eligibility to Bid" list available at the bottom of the page of the [Employment and Social](#)

[Development Canada \(ESDC\) - Labour's](https://www.canada.ca/en/employment-social-development/programs/employment-equity/federal-contractor-program.html#) website (<https://www.canada.ca/en/employment-social-development/programs/employment-equity/federal-contractor-program.html#>).

Canada will have the right to declare a bid non-responsive if the Bidder, or any member of the Bidder if the Bidder is a Joint Venture, appears on the "FCP Limited Eligibility to Bid" list at the time of contract award.

PART 6 - RESULTING CONTRACT CLAUSES

Delete this title and the following sentence at contract award

The following clauses and conditions apply to and form part of any contract resulting from the bid solicitation.

6.1 Security Requirements

6.1.1 There is no security requirement applicable to the Contract.

6.2 Statement of Work

The Contractor must perform the Work in accordance with the Statement of Work at Annex "A".

6.3 Standard Clauses and Conditions

All clauses and conditions identified in the Contract by number, date and title are set out in the [Standard Acquisition Clauses and Conditions Manual](https://buyandsell.gc.ca/policy-and-guidelines/standard-acquisition-clauses-and-conditions-manual) (<https://buyandsell.gc.ca/policy-and-guidelines/standard-acquisition-clauses-and-conditions-manual>) issued by Public Works and Government Services Canada.

6.3.1 General Conditions

[2010A](#) (2018-06-21), General Conditions- Goods (Medium Complexity) apply to and form part of the Contract.

[2010C](#) (2018-06-21), General Conditions - Services (Medium Complexity) apply to and form part of the Contract.

6.4 Term of Contract

6.4.1 Period of the Contract

The period of the Contract is from date of Contract to March 31, 2020 inclusive.

6.4.2 Delivery Date

All the deliverables must be received on or before March 31, 2020.

6.4.3 Delivery Points

Delivery of the requirement will be made to delivery point(s) specified at Annex "A" of the Contract.

6.5 Authorities

6.5.1 Contracting Authority

The Contracting Authority for the Contract is:

Name: Monique Mader
Title: Senior Advisor, Procurement & Contracting
Veterans Affairs Canada
Telephone: 902-626-2771
E-mail address: Monique.mader@canada.ca

The Contracting Authority is responsible for the management of the Contract and any changes to the Contract must be authorized in writing by the Contracting Authority. The Contractor must not perform work in excess of or outside the scope of the Contract based on verbal or written requests or instructions from anybody other than the Contracting Authority.

6.5.2 Project Authority

The Project Authority for the Contract is:

Name: _____
Title: _____
Organization: _____
Address: _____

Telephone: ____ ____ _____
Facsimile: ____ ____ _____
E-mail address: _____

The Project Authority is the representative of the department or agency for whom the Work is being carried out under the Contract and is responsible for all matters concerning the technical content of the Work under the Contract. Technical matters may be discussed with the Project Authority, however the Project Authority has no authority to authorize changes to the scope of the Work. Changes to the scope of the Work can only be made through a contract amendment issued by the Contracting Authority.

6.5.3 Contractor's Representative

Fill in or delete as applicable

6.6 Proactive Disclosure of Contracts with Former Public Servants

By providing information on its status, with respect to being a former public servant in receipt of a [Public Service Superannuation Act](#) (PSSA) pension, the Contractor has agreed that this information will be reported on departmental websites as part of the published proactive disclosure reports, in accordance with [Contracting Policy Notice: 2012-2](#) of the Treasury Board Secretariat of Canada.

6.7 Payment

6.7.1 Basis of Payment

In consideration of the Contractor satisfactorily completing all of its obligations under the Contract, the Contractor will be paid firm unit prices as specified in the contract for a cost of \$ _____ (*insert the amount at contract award*). Customs duties are included and Applicable Taxes are extra. Canada will not pay the Contractor for any design changes, modifications or interpretations of the Work, unless they have been approved, in writing, by the Contracting Authority before their incorporation into the Work.

6.7.2 Limitation of Price

SACC Manual clause C6000C (2017-08-17) Limitation of Price

6.7.3 Multiple Payments

Canada will pay the Contractor upon completion and delivery of units in accordance with the payment provisions of the Contract if:

- a. an accurate and complete invoice and any other documents required by the Contract have been submitted in accordance with the invoicing instructions provided in the Contract;
- b. all such documents have been verified by Canada;
- c. the Work delivered has been accepted by Canada.

6.7.4 Electronic Payment of Invoices – Contract

The Contractor accepts to be paid using any of the following Electronic Payment Instrument(s):

- a. Direct Deposit (Domestic and International);

6.8 Invoicing Instructions

1. The Contractor must submit invoices in accordance with the section entitled "Invoice Submission" of the general conditions. Invoices cannot be submitted until all work identified in the invoice is completed.

Each invoice must be supported by:

- a. a copy of the release document and any other documents as specified in the Contract;
2. Invoices must be distributed as follows:
 - a. The original must be forwarded to the address shown on page 1 of the Contract for certification and payment.

6.9 Certifications and Additional Information

6.9.1 Compliance

Unless specified otherwise, the continuous compliance with the certifications provided by the Contractor in its bid or precedent to contract award, and the ongoing cooperation in providing additional information are conditions of the Contract and failure to comply will constitute the Contractor in default. Certifications are subject to verification by Canada during the entire period of the Contract.

6.10 Applicable Laws

The Contract must be interpreted and governed, and the relations between the parties determined, by the laws in force in Prince Edward Island.

6.11 Priority of Documents

If there is a discrepancy between the wording of any documents that appear on the list, the wording of the document that first appears on the list has priority over the wording of any document that subsequently appears on the list.

- (a) the Articles of Agreement;
- (b) the general conditions 2010A (2018-06-21), General Conditions- Goods (Medium Complexity) ;
- (c) the general conditions 2010C (2018-06-21), General Conditions - Services (Medium Complexity);
- (d) Annex A, Statement of Work;
- (e) the Contractor's bid dated _____ (*insert date of bid*) (*If the bid was clarified or amended, insert at the time of contract award: “, as clarified on _____” or “, as amended on _____” and insert date(s) of clarification(s) or amendment(s)*)

6.12 SACC Manual Clauses

SACC Reference	Section	Date
B7500C	Excess Goods	2006-06-16
G1005C	Insurance-No Specific Requirement	2016-01-28

Site Regulations

The Contractor must comply with all regulations, instructions and directives in force on the site where the Work is performed.

**ANNEX "A"
STATEMENT OF WORK**

**Veteran Grave Marker Maintenance
Various Cemeteries, Halifax Regional Municipality, Nova Scotia**

Background

Veterans Affairs Canada (VAC) is responsible for the care and maintenance of approximately 220,000 Veterans’ graves and grave markers across Canada, including cleaning and aligning existing markers and removing and installing new markers.

Location of Work

Halifax Regional Municipality, Nova Scotia.

Contracting Requirements

1. Contractor will be required to provide all labour, material and equipment necessary for the supply, delivery, and installation of the following deliverables over two fiscal years (April 1, 2018-March 31, 2019 and April 1, 2019-March 31, 2020) in four cemeteries:

Fiscal Year 2018-2019

<u>1. Mount Olivet Cemetery, Halifax, Nova Scotia</u>		
Marker Type	Work Requirements	Quantity
Upright Granite	Clean	37
Upright Granite	Clean& align	8
Upright Granite	Align	1
Upright Granite	Supply and install new base foundation, install existing marker and clean	2
Upright Granite	Supply and install new marker with base foundation	4
Flat Granite	Clean	68
Flat Granite	Clean & align	9
Flat Granite	Align	1
Flat Granite	Supply and install new base foundation and clean and install existing marker	1

Flat Granite	Flat Granite – Supply and install new marker with base foundation	10
--------------	---	----

2.Gate of Heaven Cemetery - Lower Sackville, Nova Scotia		
Marker Type	Work Requirements	Quantity
Upright Granite	Clean	51
Upright Granite	Clean& align	63
Upright Granite	Clean & grout	2
Upright Granite	Clean & sink foundation	1
Upright Granite	Grout to base	2
Upright Granite	Align	37
Upright Granite	Supply and install new base foundation and install existing marker	1
Upright Granite	Supply and install new base foundation, install existing marker and clean	9
Upright Granite	Supply and install new marker with foundation	4
Flat Granite	Clean	68
Flat Granite	Clean & align	56
Flat Granite	Clean & sink foundation	1
Flat Granite	Sink foundation	1
Flat Granite	Align	31
Flat Granite	Supply and install new marker with base foundation	27
Upright Granite Laid Flat	Clean	9
Upright Granite Laid Flat	Clean & align	2
Upright Granite Laid Flat	Supply and install new base foundation, install existing marker and clean	6

Fiscal Year 2019-2020

3.Camp Hill Cemetery - Halifax Nova Scotia		
Marker Type	Work Requirements	Quantity
Upright Granite	Clean	76
Upright Granite	Clean& align	25
Upright Granite	Clean & sink foundation	5
Upright Granite	Align	1
Upright Granite	Clean, align, trim shrubs	1
Upright Granite	Supply and install new base foundation and install existing marker	1
Upright Granite	Supply and install new base foundation, install existing marker and clean	7
Upright Granite	Supply and install new marker with foundation	3
Flat Granite	Clean	76
Flat Granite	Clean & align	25
Flat Granite	Clean & sink foundation	5
Flat Granite	Clean & trim shrubs	1
Flat Granite	Trim shrubs	1
Flat Granite	Align	9
Flat Granite	Supply and install new base foundation and clean and install existing marker	7
Flat Granite	Supply and install new marker with base foundation	3
Upright Granite Laid Flat	Supply and install new base foundation, install existing marker and clean	1

4.St. John’s Cemetery and Columbarium – Halifax, Nova Scotia		
Marker Type	Work Requirements	Quantity
Upright Granite	Clean	48
Upright Granite	Clean& align	2
Upright Granite	Clean & sink foundation	1
Upright Granite	Supply and install new base foundation and install existing marker	5
Upright Granite	Supply and install new base foundation, install existing marker and clean	2
Upright Granite	Supply and install new marker with foundation	1
Flat Granite	Clean	14
Flat Granite	Clean & align	1
Flat Granite	Clean & sink foundation	1
Flat Granite	Supply and install new marker with base foundation	5

Contingency-In addition to the above detailed work, if there are issues that arise as a result of complications when trying to align, replace, grout, trim shrubs or repair markers, it is beneficial to have a contingency fund associated with this contract that would cover necessary repairs, replacement markers and base foundations. Prior to commencing any additional work or purchasing new markers or bases, the Project Authority must be contacted and give authority to proceed with the repairs or replacement. This amount is not to exceed the additional 5% + HST per cemetery, calculated in the Basis of Payment at Annex B.

2. Provide all labour, material and equipment required for the removal and proper disposal of all debris associated with the work.
3. Complete any landscaping required to bring the site to its original state. Any required sod or seeding must be completed at each new or repaired marker.
4. Provide photographs of all new and repaired markers as per specifications contained in Appendix C. NOTE: All photographs must be submitted on CD to the Project Authority.

Additional Contracting Information

- All work must be completed in accordance with Section 4 and Section 5 of the Veterans Affairs Canada National Technical Maintenance Manual, applicable sections attached as Appendix A and Appendix B.
- As per the terms and conditions of the contract, every marker on which maintenance has been completed must be photographed, burned on a CD and sent to the Project Authority. Pictures will include both the marker and foundation and should be taken so that the marker and foundation fill approximately 75% of the frame. Any photograph that is not taken correctly must be redone at the expense of the contractor. See Appendix C for additional instruction and hints for ensuring that photographs are acceptable. There is no requirement for photographs of markers prior to work being completed.
- Successful Contractor will be provided with a list of markers including date of death and work required, as well as GPS coordinates (if available). No new GPS coordinates are required.
- Contractor and workers must conduct themselves as professionals and adhere to all terms and conditions of the cemetery, including hours of work. Work will cease if in the immediate vicinity of a funeral, until the conclusion of the service. No work is allowed to begin on a Saturday that cannot be finished, including the removal of litter and debris, by noon of that day. No work is permitted on any Sunday or Statutory Holiday. The work area must be in a tidy state at the end of each day.

Ownership and Control

All information provided to the Contractor for the purposes of this contract, remains under the ownership and control of VAC. All applicable Federal legislation applies under all circumstances, even when such information is in the sole custody of the Contractor. Upon delivery of the final product(s) to VAC, the Contractor shall ensure that all information is returned to the project authority.

Time line and Payment

Fiscal year 2018/2019 – All required work to be completed by November 2, 2018.
Fiscal year 2019/2010 – All required work to be completed by August 2, 2019.

Invoices are to be submitted each year upon completion of all work for that Fiscal year. Government of Canada is PST exempt. Payment will not be made to the Contractor until

all requirements for work outlined for each Fiscal year are fulfilled, including proper photographs provided to the project authority on a CD.

Attachments

Appendix A – National Technical Maintenance Manual – Section 4.0

Appendix B – National Technical Maintenance Manual – Section 5.0

Appendix C – Specifications for photographs

Appendix A

National Technical Maintenance Manual-Section 4.0

4.0 STANDARDS FOR THE INSTALLATION OF GRAVESITES

4.0.1 Orientation for Gravesite Inspectors

This section provides VAC gravesite inspectors with a set of standards by which to determine the successful completion for installations of veterans' grave markers. The standards cover all aspects of the gravesites, including grave markers, their inscriptions, foundations and mounting, as well as grave surfacing, to which cemetery staff or private contractors must comply.

Whenever gravesite inspectors are assessing new installations, including replacement grave markers, this will be the most important section in the *National Technical Maintenance Manual for Veterans' Gravesites in Canada*, to determine whether to accept the new work of the contractor.

The following standards represent a process of evolution. The master policy document for the installation of veterans' gravesites is VAC's *Veterans Programs Policy Manual* [VPPM], and specifically Volume IV, Commemorative Programs, Appendices E and F, dated September 1997. The specifications from this document have since been updated by the LPF in their *Management and Operations Manual* [LPFMOM], Section 4.8.3 Grave (Memorial) Marker Specifications, dated January 22, 2002. This set of standards has in turn been analyzed by the current project team, and changes recommended in order to better control the standardization and longevity of the end products: veterans' grave markers, inscriptions, foundations, connections, and grave surfacing.

It should be noted that VAC is also responsible for supplying grave markers for service personnel of the Department of National Defence [DND] and for Civilians, i.e. First Aid workers, who have made contributions to Canada's war efforts. In addition to the standards for veterans' markers, this section will also include standards for Civilian and DND grave markers.

For the benefit of VAC and LPF staff, it should be noted that a number of changes have been made to previous marker specifications, particularly in the subsection on inscriptions, in order to correct errors or omissions. Some of these changes include:

- specifying 6mm (¼") minimum depth for all inscriptions in order to ensure legibility;
- specifying 25mm (1") minimum height for all inscribed letters in order to ensure that the minimum depth of inscription can be achieved from the sand blast process;
- changing the maximum number of letter spaces on lines of inscription to accommodate the changed letter sizes;
- adjusting the sizes of flat, pillow and bronze markers to accommodate the increased amount of inscription text called for in LPFMOM; and
- changing letter sizes on bronze markers to accommodate the increased amount of inscription text.

Note: Cemetery bylaws may stipulate that flat markers must be a certain size. In this situation, the inspector should discuss with the cemetery authority the possibility of accepting the standards in this manual when starting a new row.

4.0.2 Replacement of Veteran Grave Markers

There are two types of veteran grave markers:

Standardized veteran grave markers - are the markers described in this section and were placed at the expense of Canada.

Non-standardized veteran grave markers - are located mostly in departmentally owned cemeteries and in South Africa. They are usually historic military style markers which pre date the First World War and in some cases Confederation (1867). Non-standardize markers may or may not have been placed at the expense of Canada, yet are the responsibility of Canada.

When replacing veteran grave markers that are the responsibility of Canada:

- replace the standardized markers with markers that replicate the originals in conjunction with the grave marker specifications identified in this section.
- replace non-standardized markers with markers that replicate as closely as possible, the original. Replacement is a last resort and should only be considered in situations where corrective conservation efforts will not save the grave marker.

The policy is to be applied worldwide.

When replacing a Victoria Cross grave marker the inscription order is as follows:

- Top - maple leaf, official military crest or religious symbol;
- 1st line - Name;
- 2nd line - Rank;
- 3rd line - Unit and Conflict if space permits;
- 4th line - Date of Death;
- 5th line - Age;
- 6th line - Victoria Cross template; and
- Bottom - A few words/quote selected by family or regiment if space permits.

When replacing a marker that has a Maple Leaf on it, replace it with the copyrighted Commonwealth War Graves Commission Maple Leaf.

4.1 Markers: Form and Size

4.1.1 Veteran's Standard Upright Granite Marker

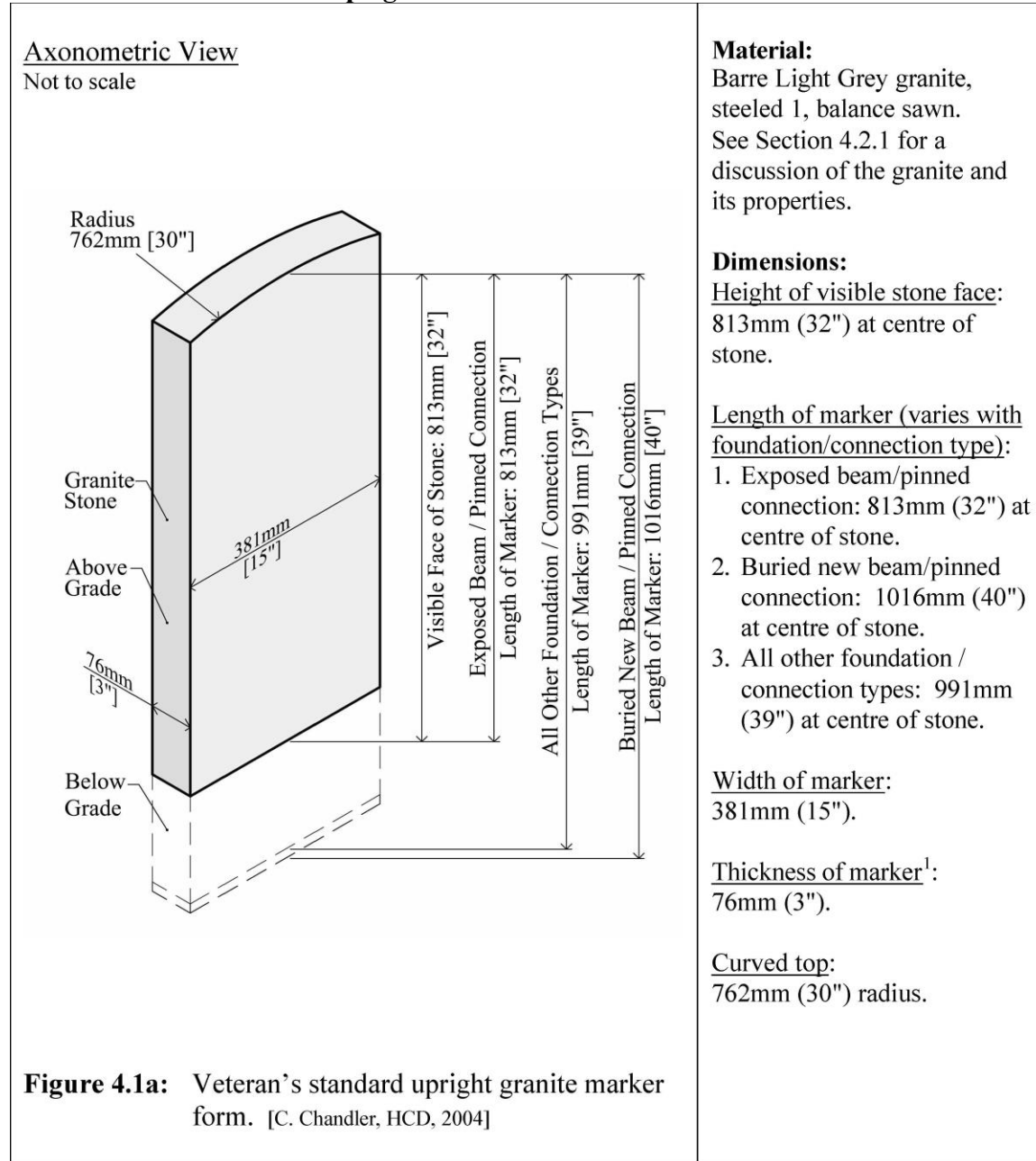

¹ Due to cemetery regulations in the Province of Ontario, the thickness of an upright marker in Ontario can be increased to 200mm (8").

4.1.2 Veteran's Standard Flat Granite Marker

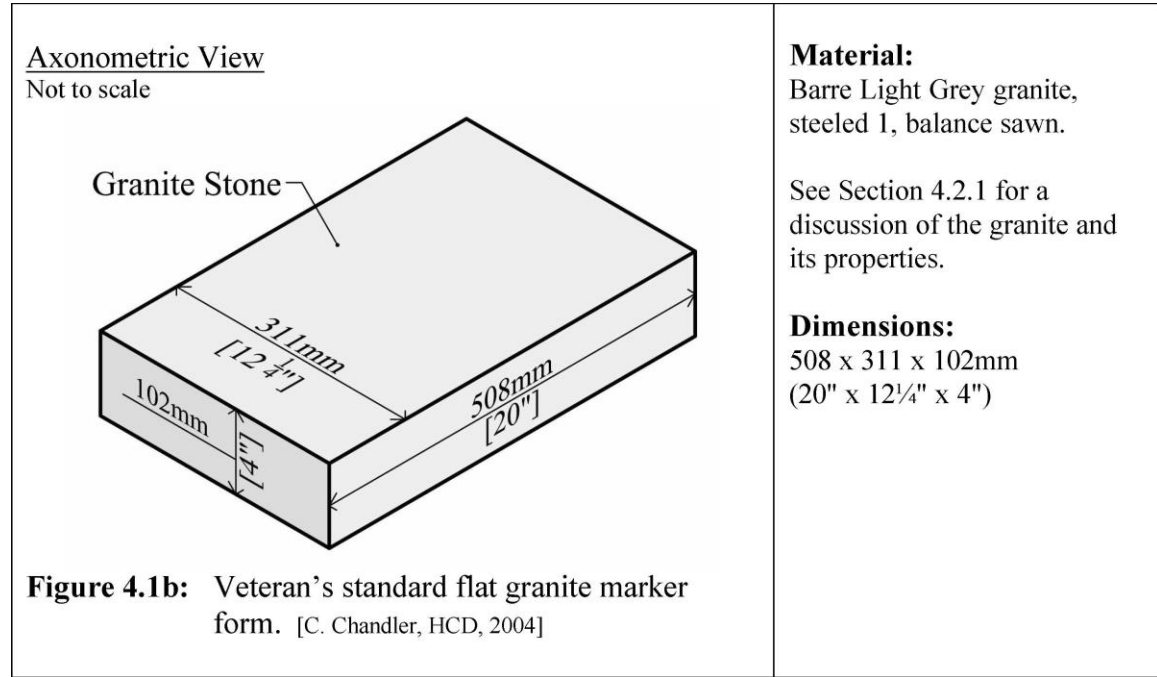

4.1.3 Veteran's Special Order Pillow Granite Marker

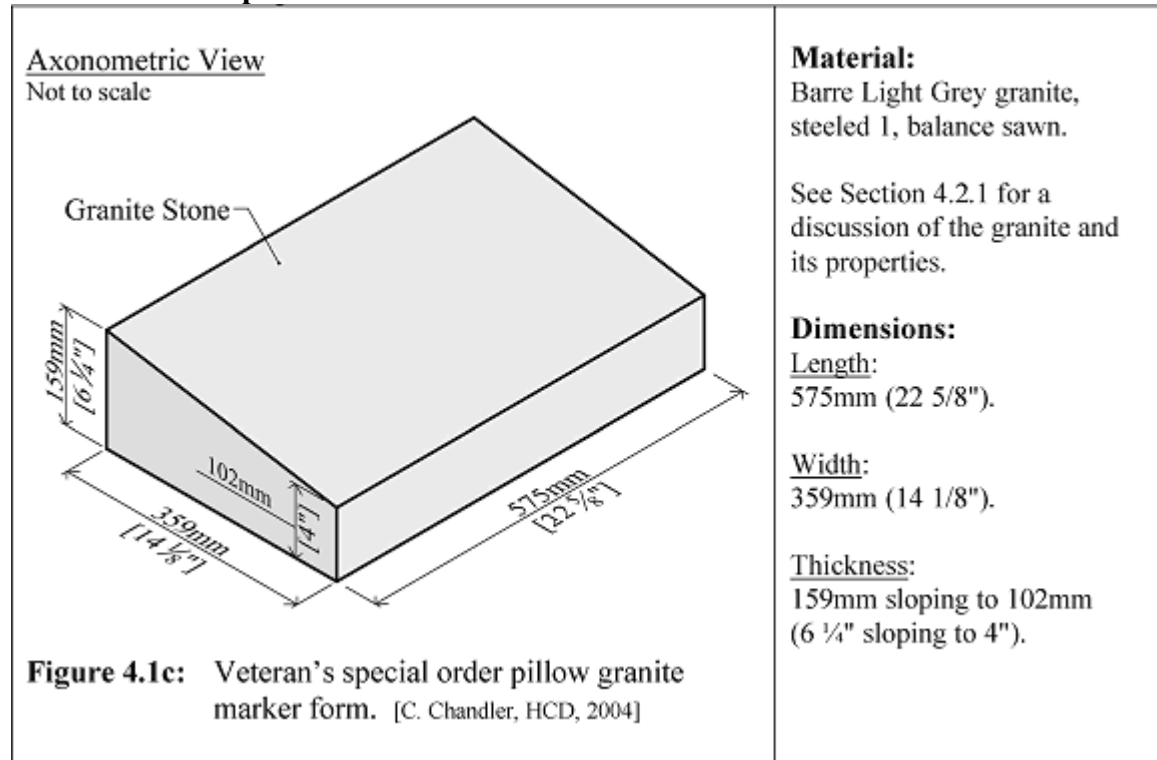

4.1.4 Veteran's Special Order Flat Bronze Marker

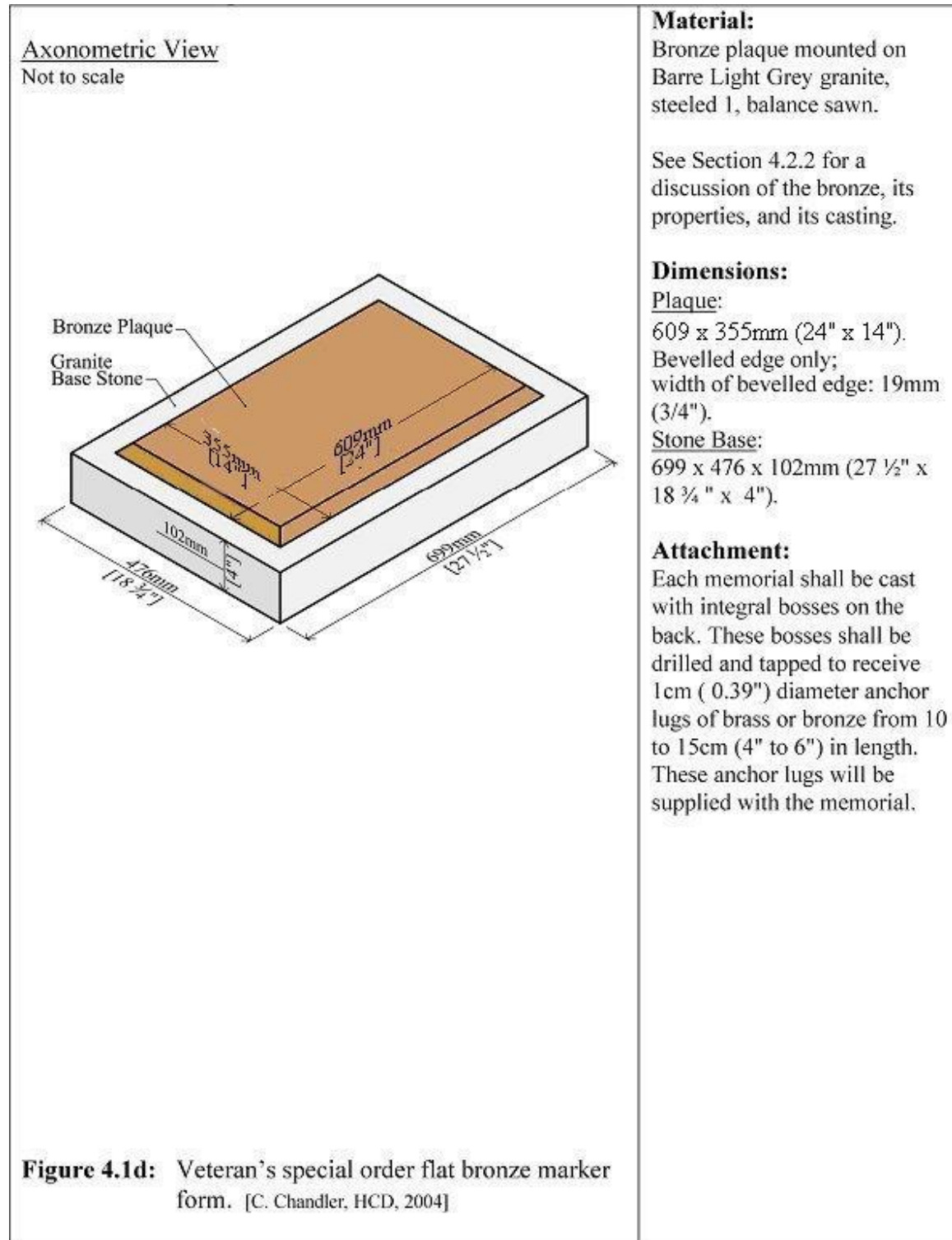

4.1.5 VAC Civilian Upright Granite Marker

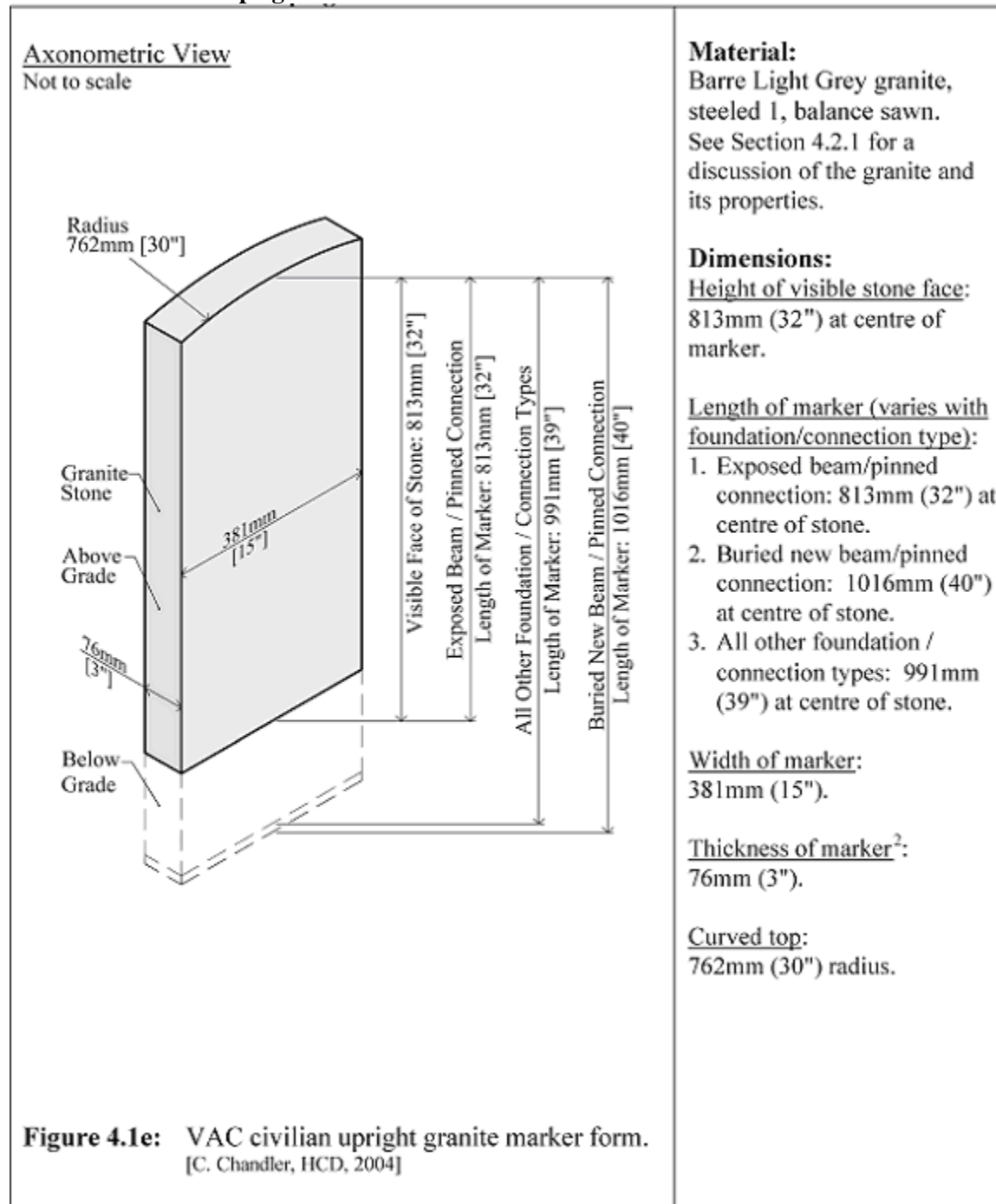

Figure 4.1e: VAC civilian upright granite marker form.
[C. Chandler, HCD, 2004]

²Due to cemetery regulations in the Province of Ontario, the thickness of an upright marker in Ontario can be increased to 200mm (8").

4.1.6 VAC Civilian Flat Granite Marker

Axonometric View

Not to scale

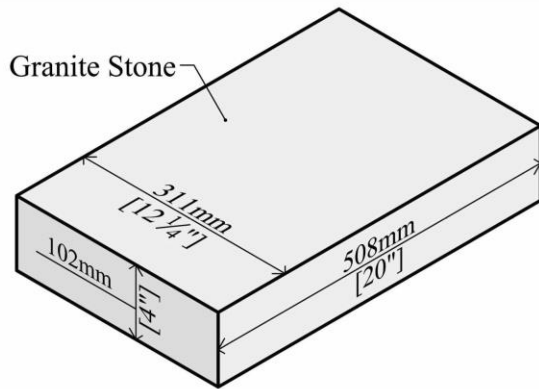

Figure 4.1f: VAC civilian flat granite marker form. [C. Chandler, HCD, 2004]

Material:

Barre Light Grey granite, steeled 1, balance sawn.

See Section 4.2.1 for a discussion of the granite and its properties.

Dimensions:

508 x 311 x 102mm
(20"x 12 1/4"x 4").

4.1.7 VAC Civilian Flat Bronze Marker

Axonometric View

Not to scale

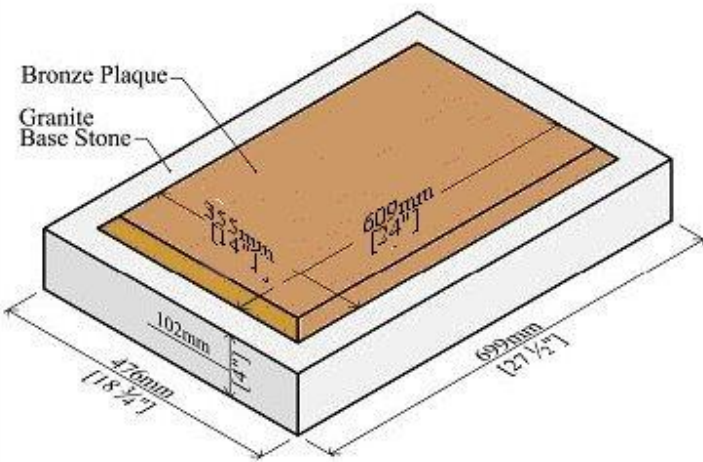

Figure 4.1g: VAC civilian flat bronze marker form. [C. Chandler, HCD, 2004]

Material: Bronze plaque mounted on Barre Light Grey granite, steeled 1, balance sawn. See Section 4.2.2 for discussion of bronze, its properties, and casting.

Dimensions: Plaque: 609 x 355mm (24" x 14"). Bevelled edge only; width of bevelled edge: 20mm (3/4"). Stone Base: 699 x 476 x 102mm (27 1/2"x 18 3/4 "x 4").

Attachment: Memorial cast with integral bosses on back. Bosses drilled and tapped to receive 10mm (0.39") diameter anchor lugs of brass or bronze, from 102-152mm (4"- 6") in length. Anchor lugs supplied with the memorial.

4.1.8 DND Upright Granite Marker

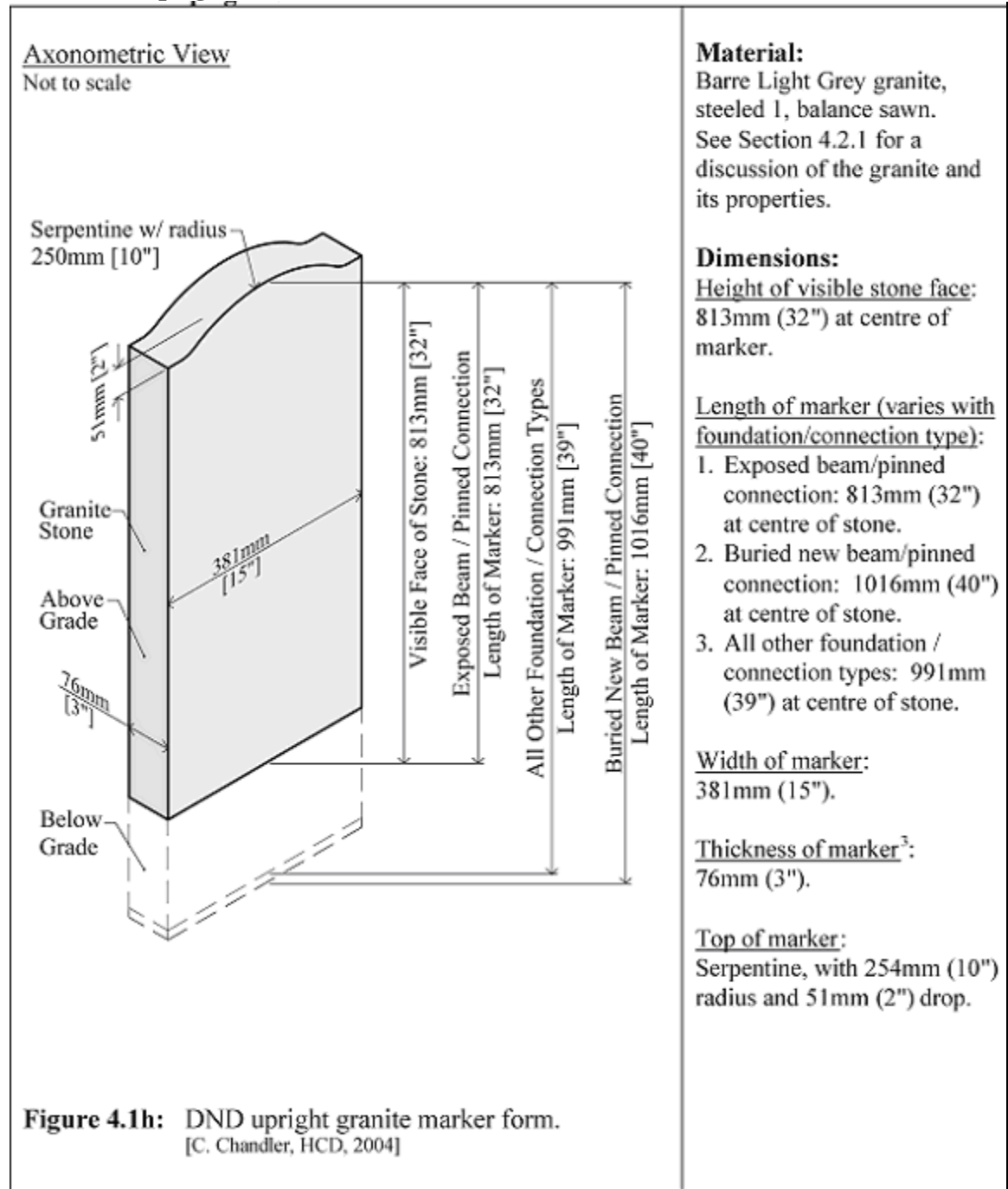

Due to cemetery regulations in the Province of Ontario, the thickness of an upright marker in Ontario can be increased to 200mm (8").

4.1.9 DND Flat Granite Marker

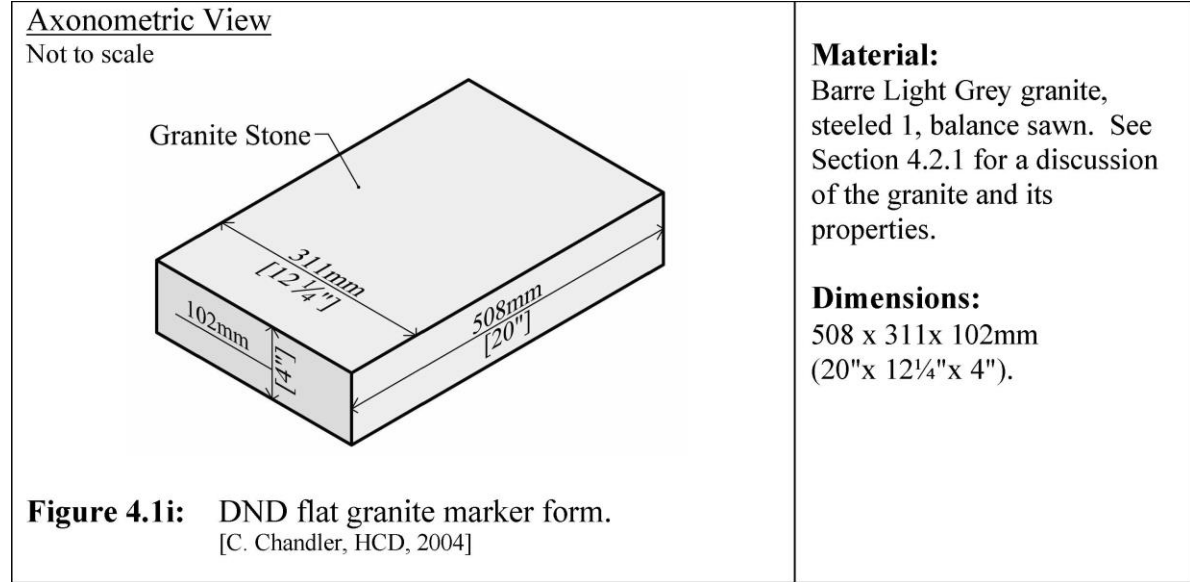

4.1.10 DND Flat Bronze Marker

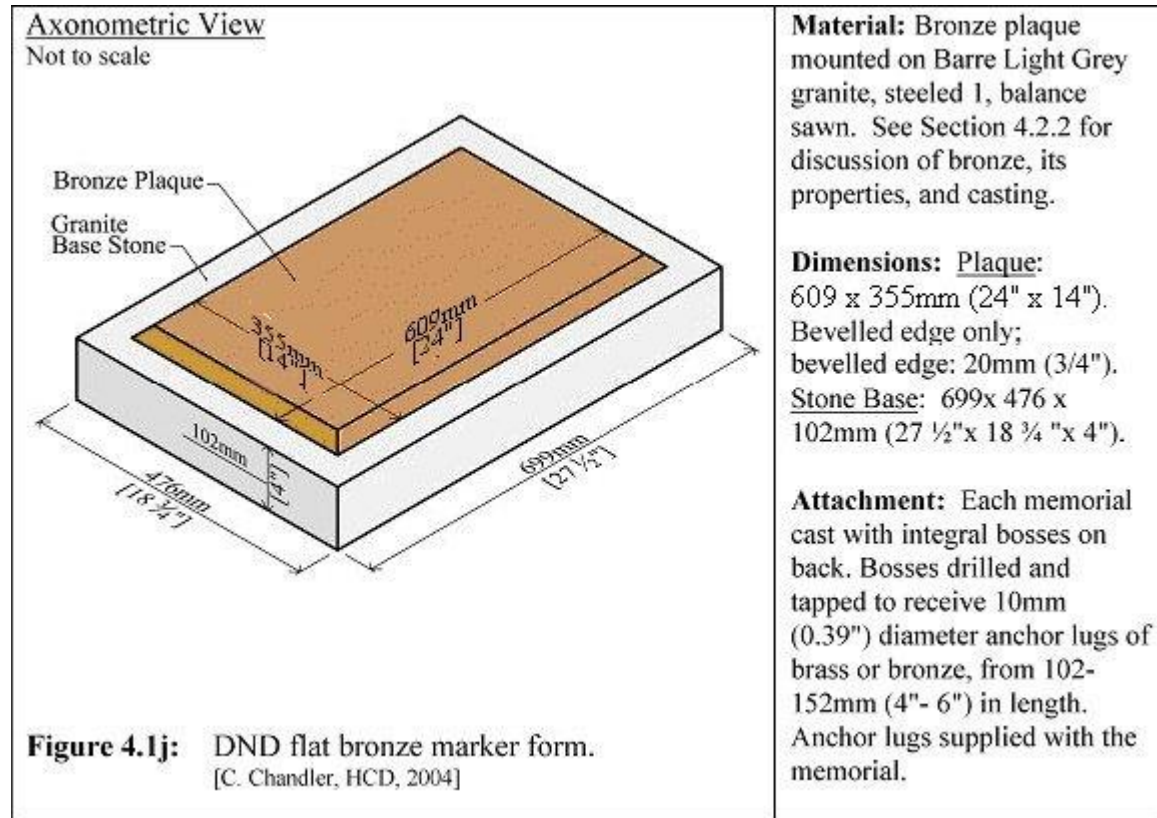

4.1.11 Cremation Markers

VAC has no standard form for markers indicating the interment of cremated remains. Typically cremated remains are interred either in the ground or above ground in columbaria. For veteran, VAC civilian and DND interments, grave markers for cremated remains should follow cemetery specifications as set out by cemetery authorities.

4.1.12 General Guidelines for Other Forms

Because of VAC's willingness to accommodate local cemeteries when the forms of the standard or special order LPF or VAC grave markers are not acceptable to a cemetery, a number of other forms have been used occasionally within Canada for veterans' graves. A number of these other marker forms fabricated from granite and occasionally from concrete, were observed during the site visits for this manual. The marker forms that were observed include: wedge-shaped markers, and scroll-shaped markers.



Figure 4.1k: Wedge-shaped marker. **Figure 4.1l:** Scroll-shaped marker.

[D. Stephenson, HCD, 2003][D. Stephenson, HCD, 2003]

Because the current researchers visited only a small fraction of the cemeteries that contain veterans' graves, it is highly likely that there are additional 'other' marker forms in place at veterans' graves within Canada. It is impossible to provide standards for all the other forms that exist. However, it is recommended that when grave site inspectors encounter markers other than the standard and special order forms, they approach pertinent cemetery administrators to request specifications for these unusual markers in use. In this way a collection of fabrication standards for other forms of veterans' grave markers can be built up and added to this technical maintenance manual, if appropriate.

4.2 Markers: Materials and Alignment

4.2.1 Granite and Its Properties

The standard granite type for new VAC grave markers is listed in the LPFMOM as Barre Light Grey. Barre Light Grey granite is the VAC and LPF name for Barre Gray granite that is supplied under a registered trademark by Rock of Ages Corporation, P.O. Box 482, Barre Vermont 05641, USA.

The mechanical properties of Barre Gray, obtained from Rock of Ages, are noted in the table below.

Table 4.2a		Mechanical Properties for Barre Gray Granite	
ASTM Test		Mechanical property	Average
ASTM C97-96 <i>Absorption and Bulk Specific Gravity</i>	Absorption	.206%	
	Bulk Specific Gravity	166 lbs/ft ³	
ASTM C99-87 <i>Modulus of Rupture</i>	Perpendicular dry	2909 psi	
	Perpendicular wet	2621 psi	
	Parallel dry	2142 psi	
	Parallel wet	1900 psi	
ASTM C170-90 <i>Compressive Strength</i>	Perpendicular dry	29388 psi	
	Perpendicular wet	25000 psi	
	Parallel dry	23899 psi	
	Parallel wet	16293 psi	
ASTM C880-98 <i>Flexural Strength</i>	Perpendicular dry	2769 psi	
	Perpendicular wet	2437 psi	
	Parallel dry	1917 psi	
	Parallel wet	1567 psi	

4.2.2 Bronze, Its Properties and Casting

The cemetery bronze alloy shall consist of :

- Copper.....82-87%
- Tin.....3-7%
- Lead..... 2% maximum
- Zinc..... 3-8%

Each casting shall be true, free from all weakening defects of any character, and also free from minor defects and imperfections that would be visible from a distance of 90 cm (3 feet). All exposed surfaces must be smooth. No sand-like roughness will be permitted. All letters, numerals, ornamentation and insignia shall be finely buffed and highlighted.

Backgrounds shall be of sculptured texture and shall be finished in medium dark statuary bronze colour (brown) secured by chemical means through the formation of cupreous oxide and cupric oxide on the background surface. No sulphide finishes or painted or pigmented lacquer finishes will be permitted.

4.2.3 Marker Alignment

Marker alignment refers to the relationship between individual grave markers within a grouping of markers. It is suggested that VAC follow an adaptation of the criteria developed by the CWGC in the matter of alignment. During installation every effort should be made to ensure that all markers are plumb. Upright markers should show the standard 81.3 cm (32") height of face above ground level for buried foundations, and the same height above their foundations for exposed foundations. However, the criterion for acceptance *“is that the group of markers should conform reasonably with each other, and that seen from the face or the three-quarter face, they should not appear unsightly to the practiced eye”*. (CWGC, 1999, para. 945)



Figure 4.2a: An example of a well aligned group of upright markers. [D. Stephenson, HCD, 2003]

4.3 Inscriptions: Lettering Properties and Content

4.3.1 Inscription Format for Veterans' Standard Upright Markers

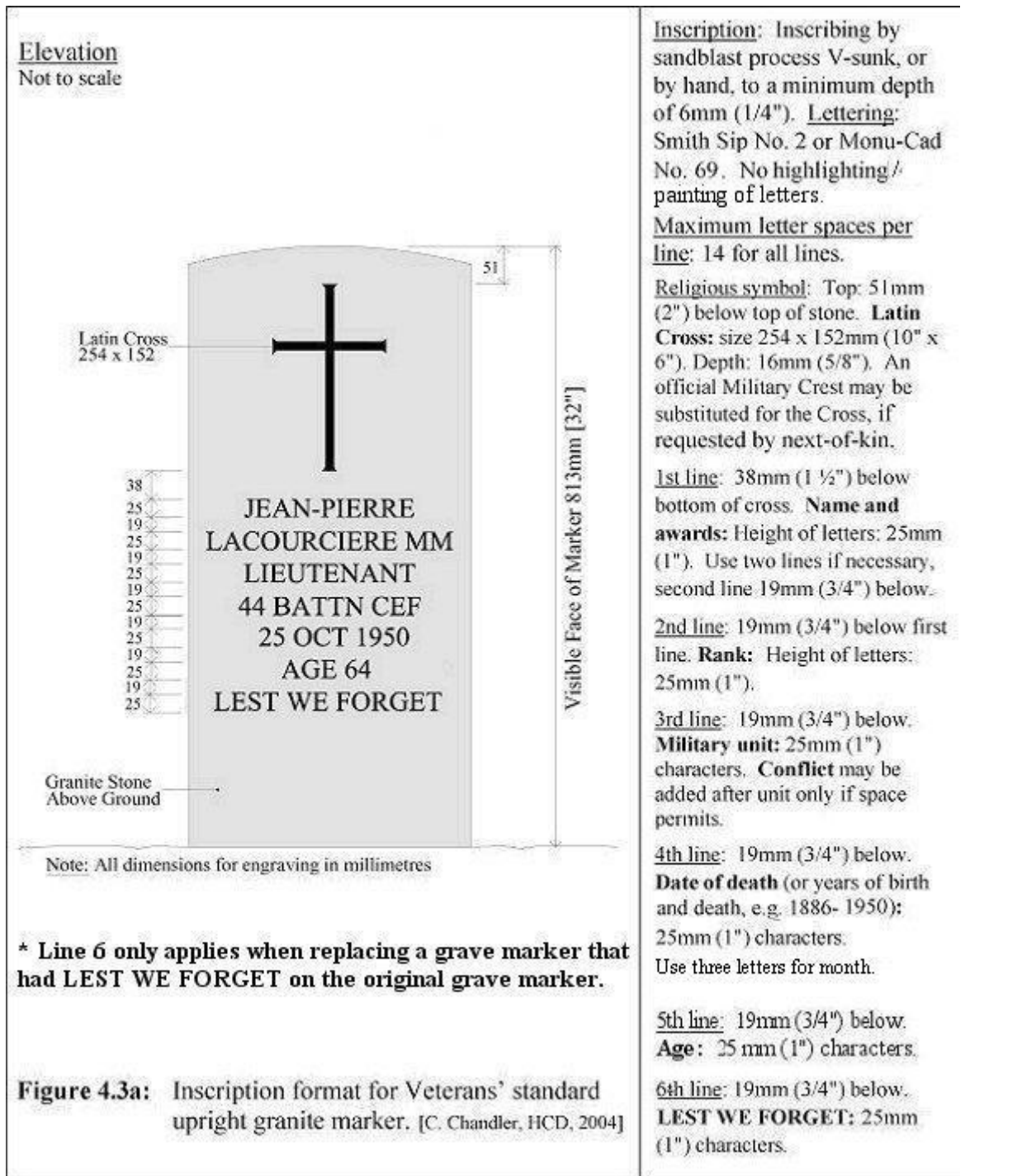

* Line 6 only applies when replacing a grave marker that had LEST WE FORGET on the original grave marker.

Figure 4.3a: Inscription format for Veterans' standard upright granite marker. [C. Chandler, HCD, 2004]

4.3.2 Inscription Format for Veterans' Standard Flat Granite Marker

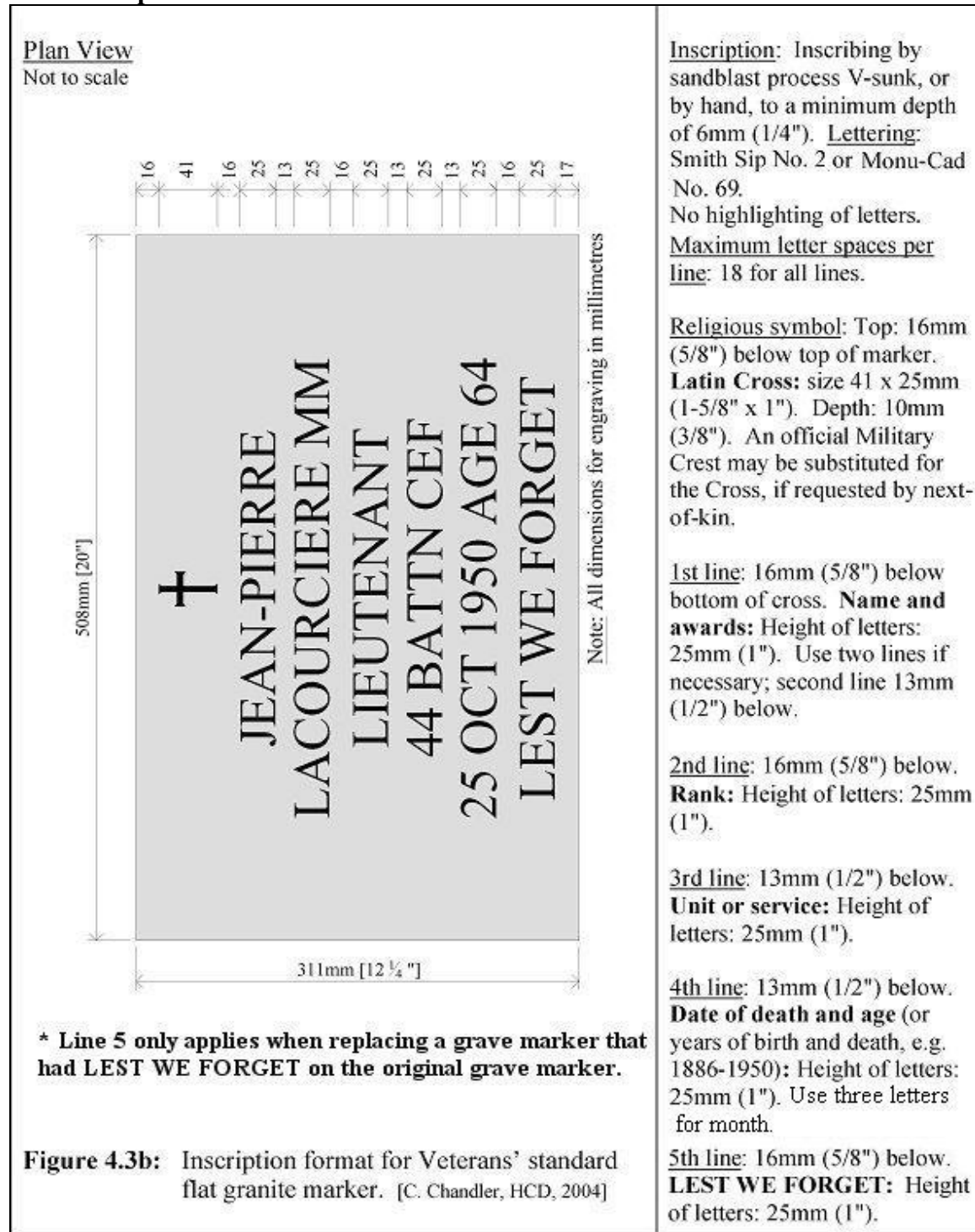

4.3.3 Inscription Format for Veterans' Special Order Pillow Marker

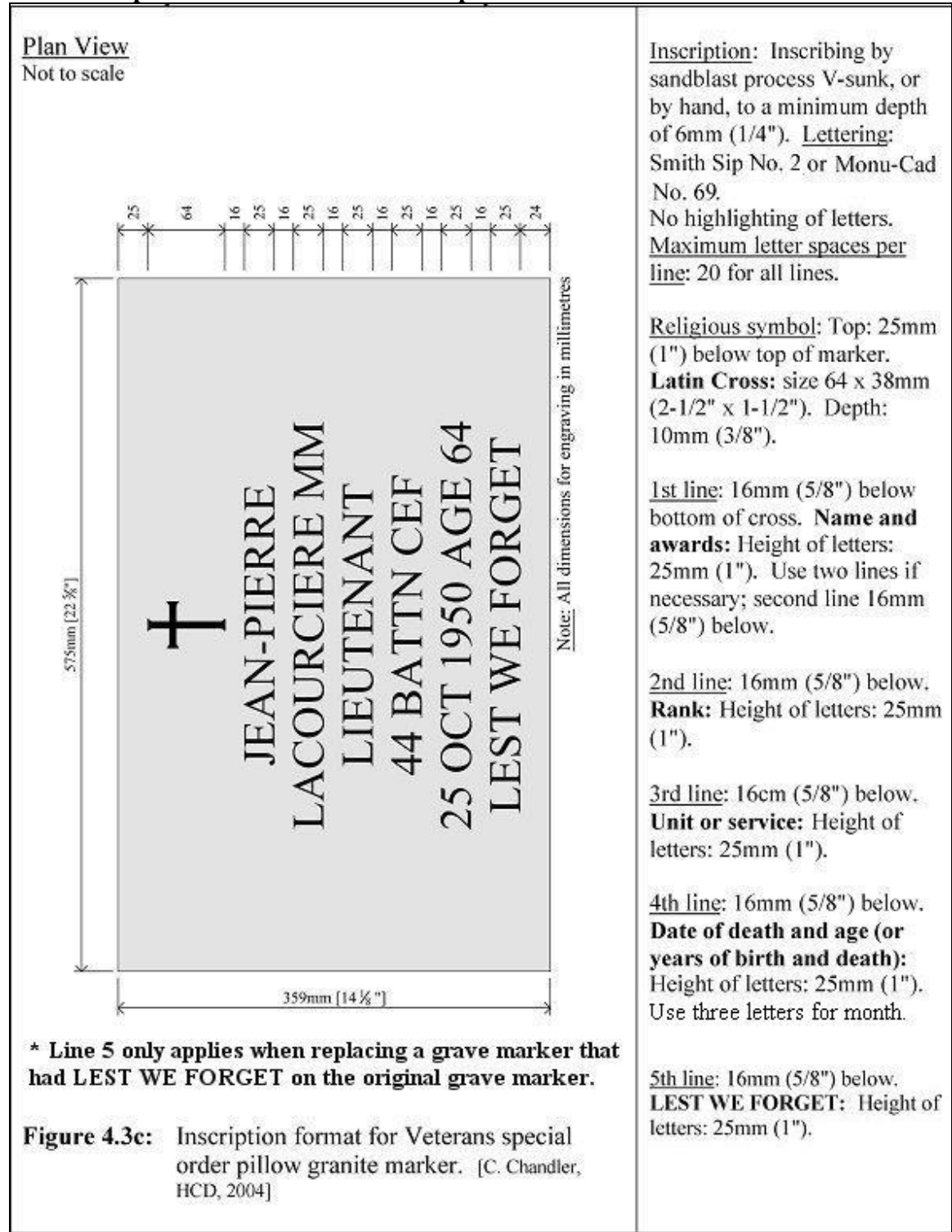

4.3.4 Inscription Format for Veterans' Special Order Flat Bronze Markers

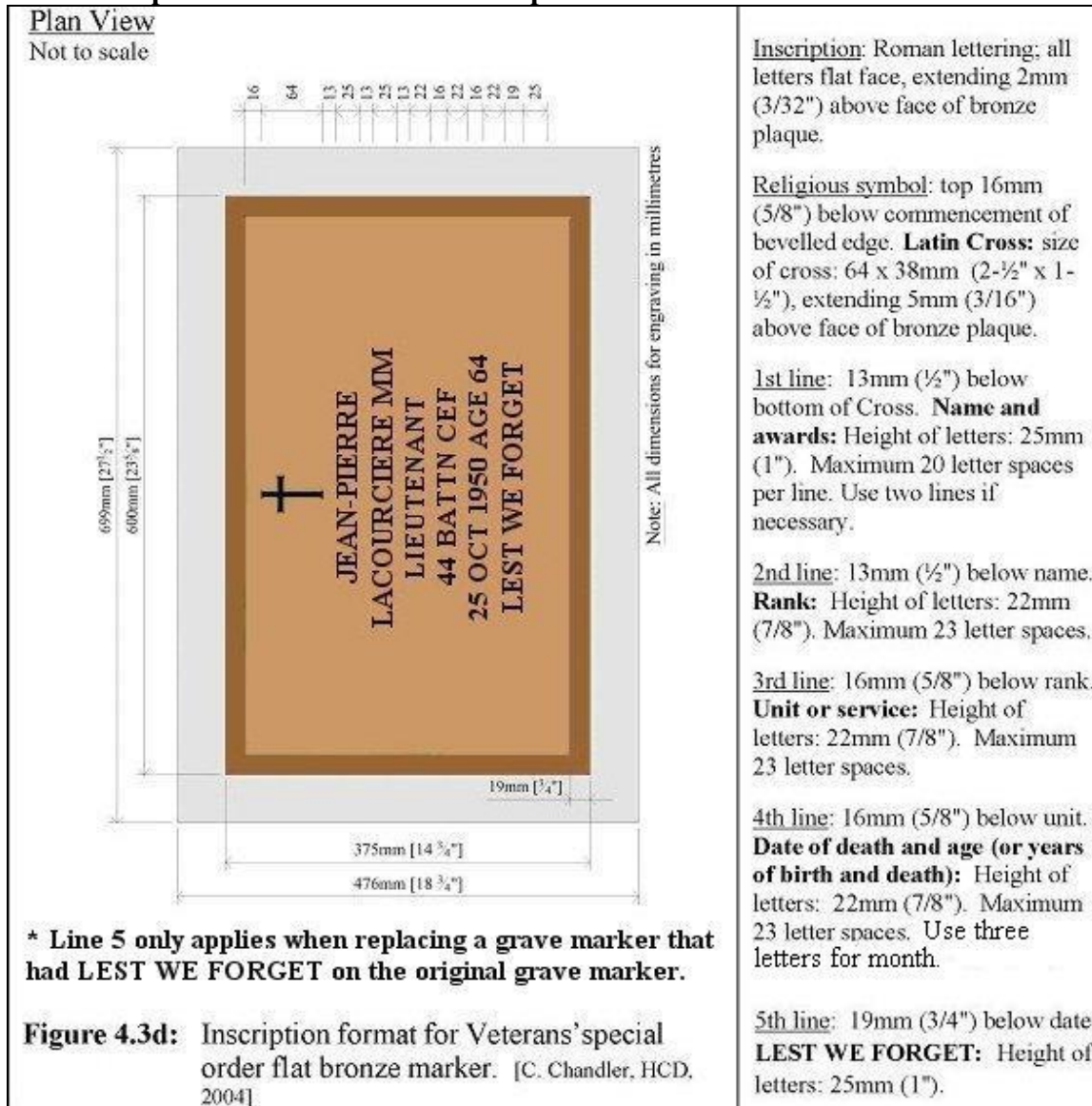

4.3.5 Inscription for Veterans' Special Order Cremation Markers

While the forms for veterans' cremation markers can follow individual cemetery specifications, their inscriptions should adhere to the specifications below:

Cross: If space permits.

1st line: Veteran's name and awards (if applicable); use two lines if necessary.

2nd line: Rank.

3rd line: Unit or Service.

4th line: Definitely containing date of death and age (or years of birth and death).

5th line: If space permits: "LEST WE FORGET". (Only applies if this was on the original marker)

4.3.6 Inscription Format for VAC Civilian Upright Granite Markers

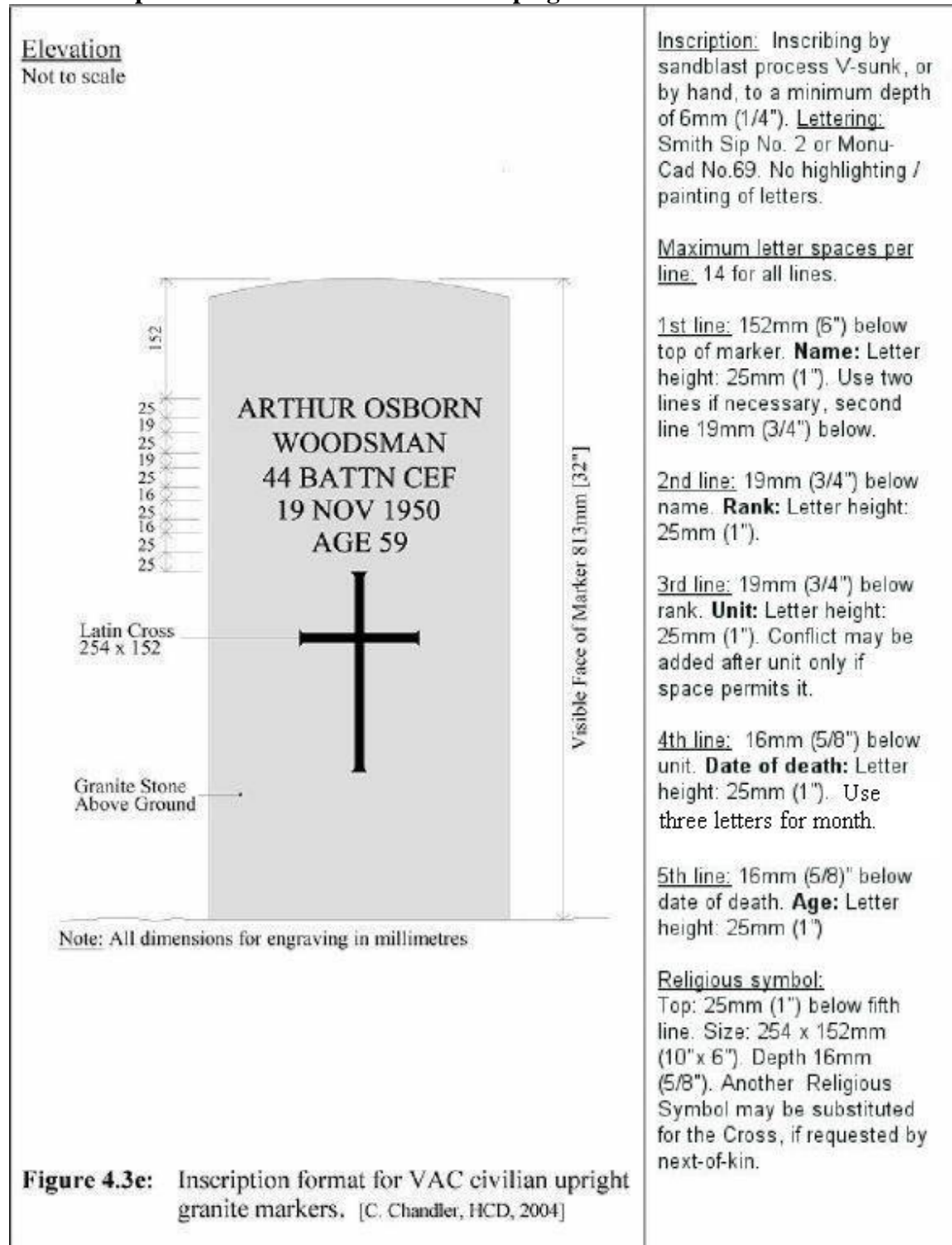

4.3.7 Inscription Format for VAC Civilian Flat Granite Markers

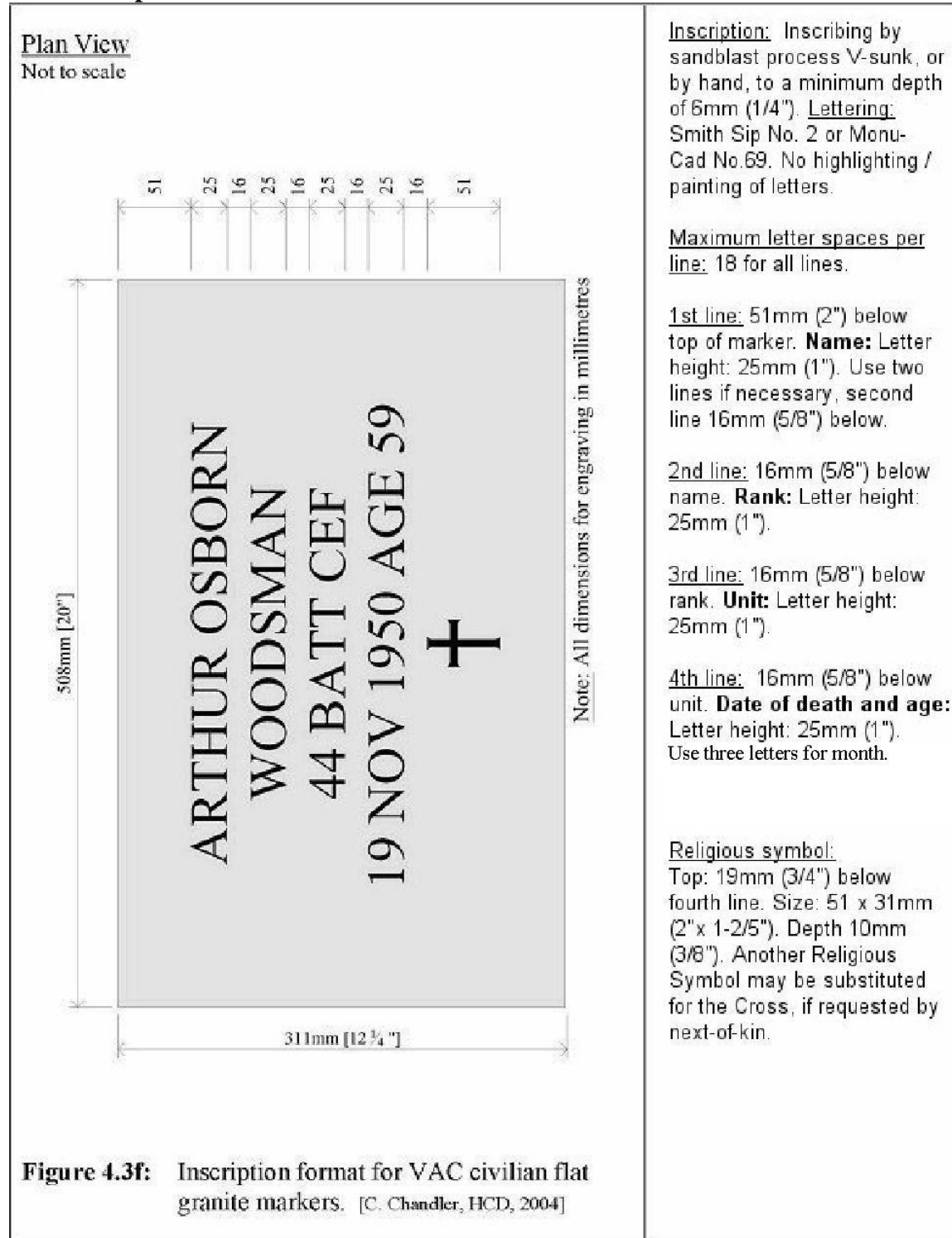
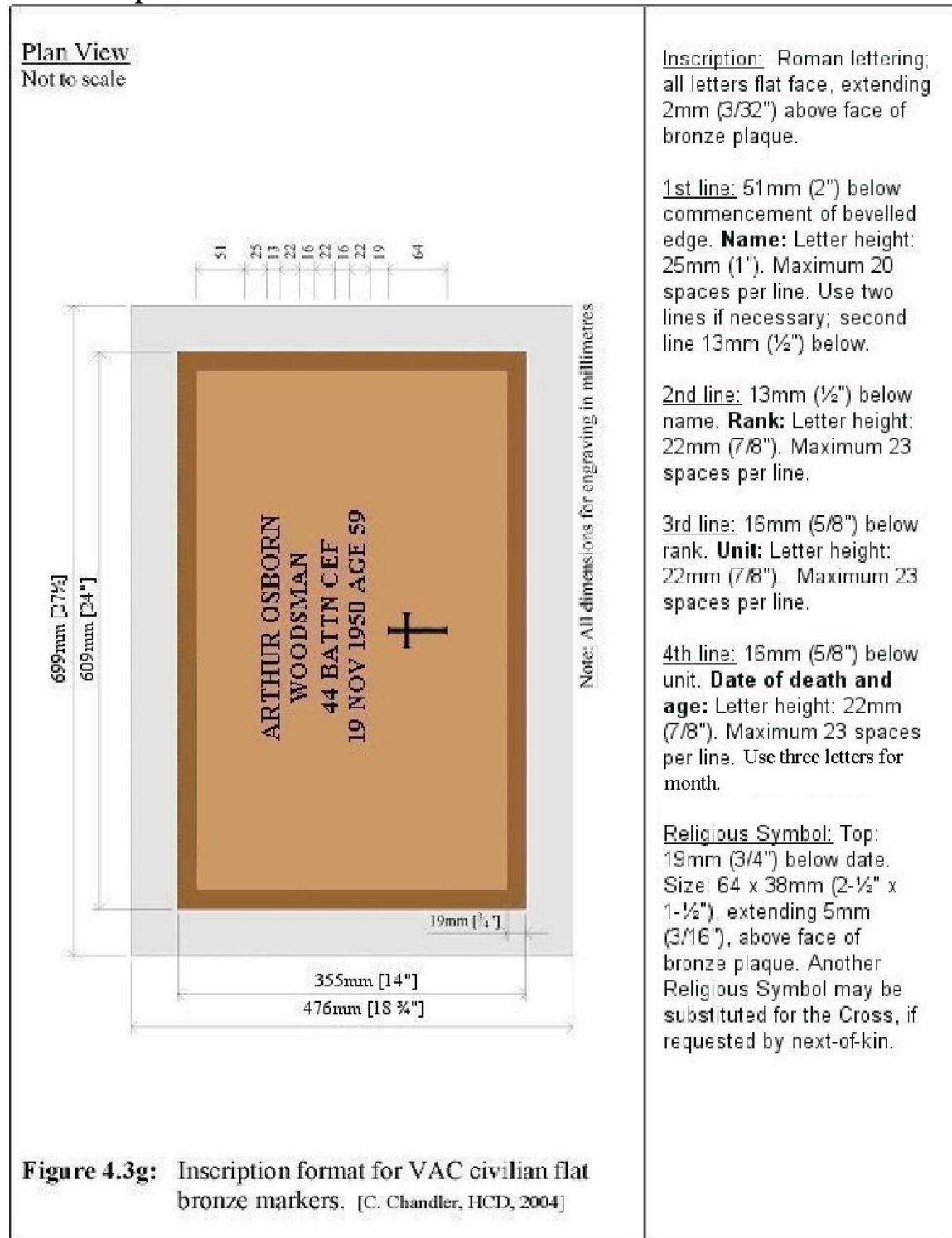
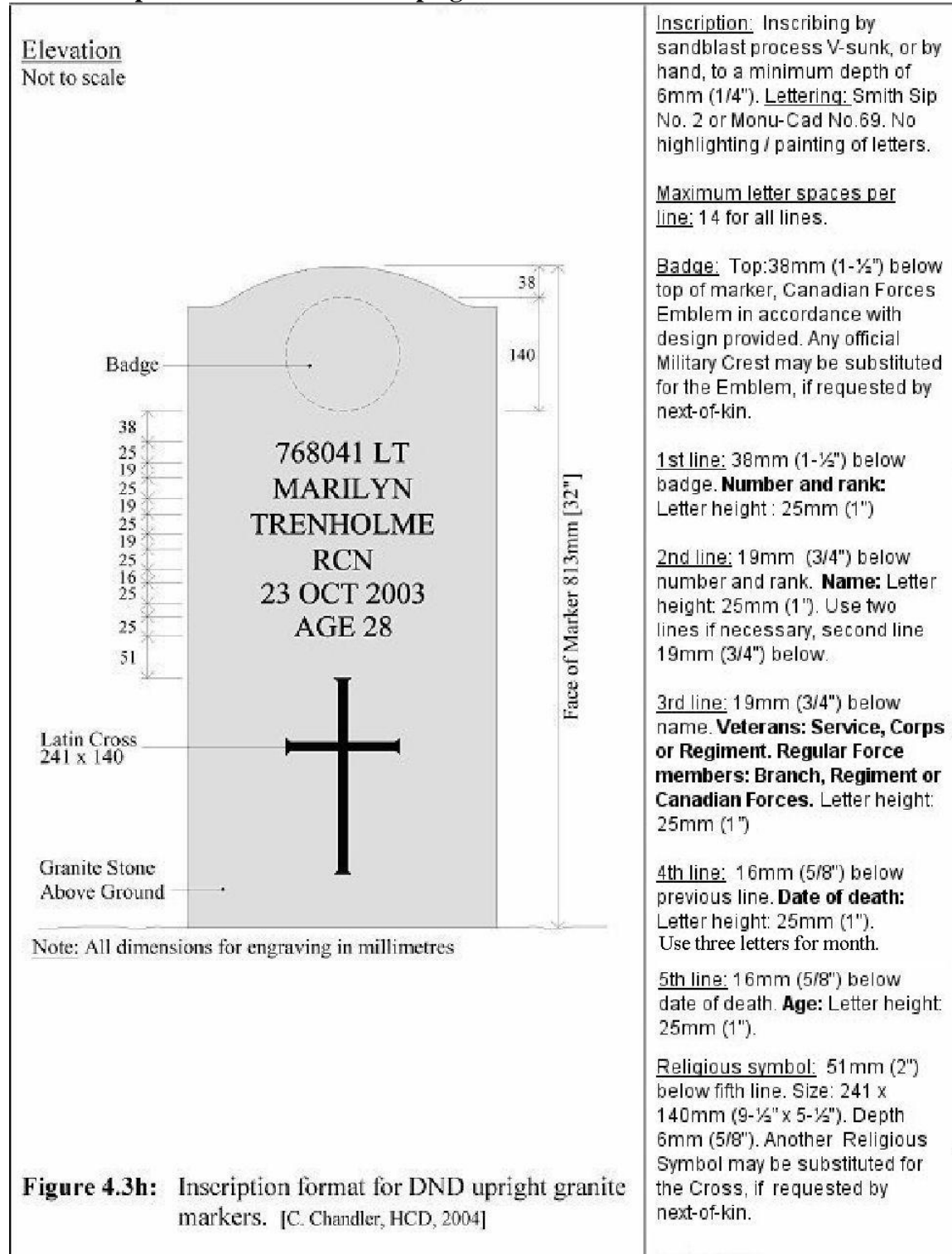

Figure 4.3f: Inscription format for VAC civilian flat granite markers. [C. Chandler, HCD, 2004]

4.3.8 Inscription Format for VAC Civilian Flat Bronze Markers



4.3.9 Inscription Format for DND Upright Granite Markers



4.3.10 Inscription Format for DND Flat Granite Marker

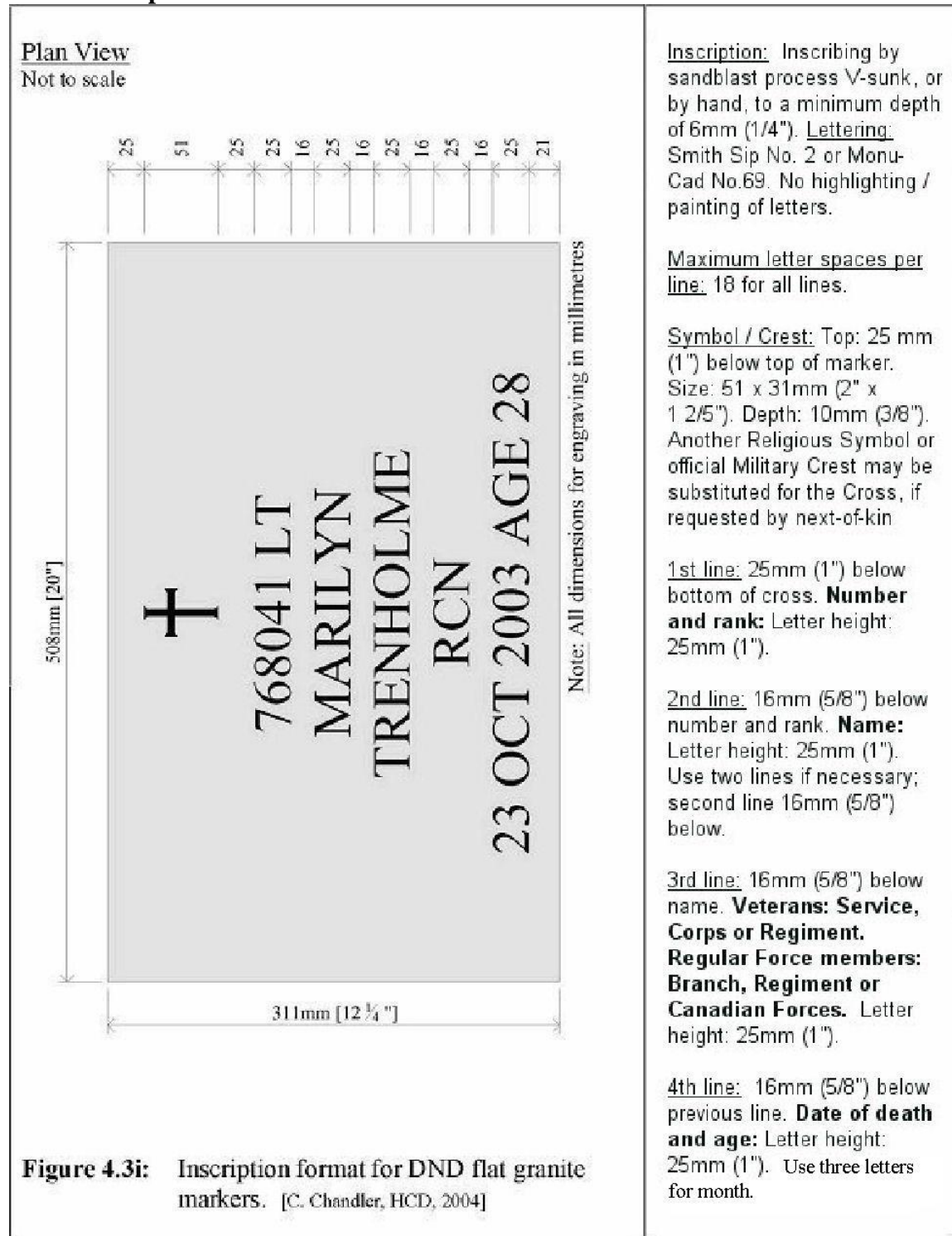
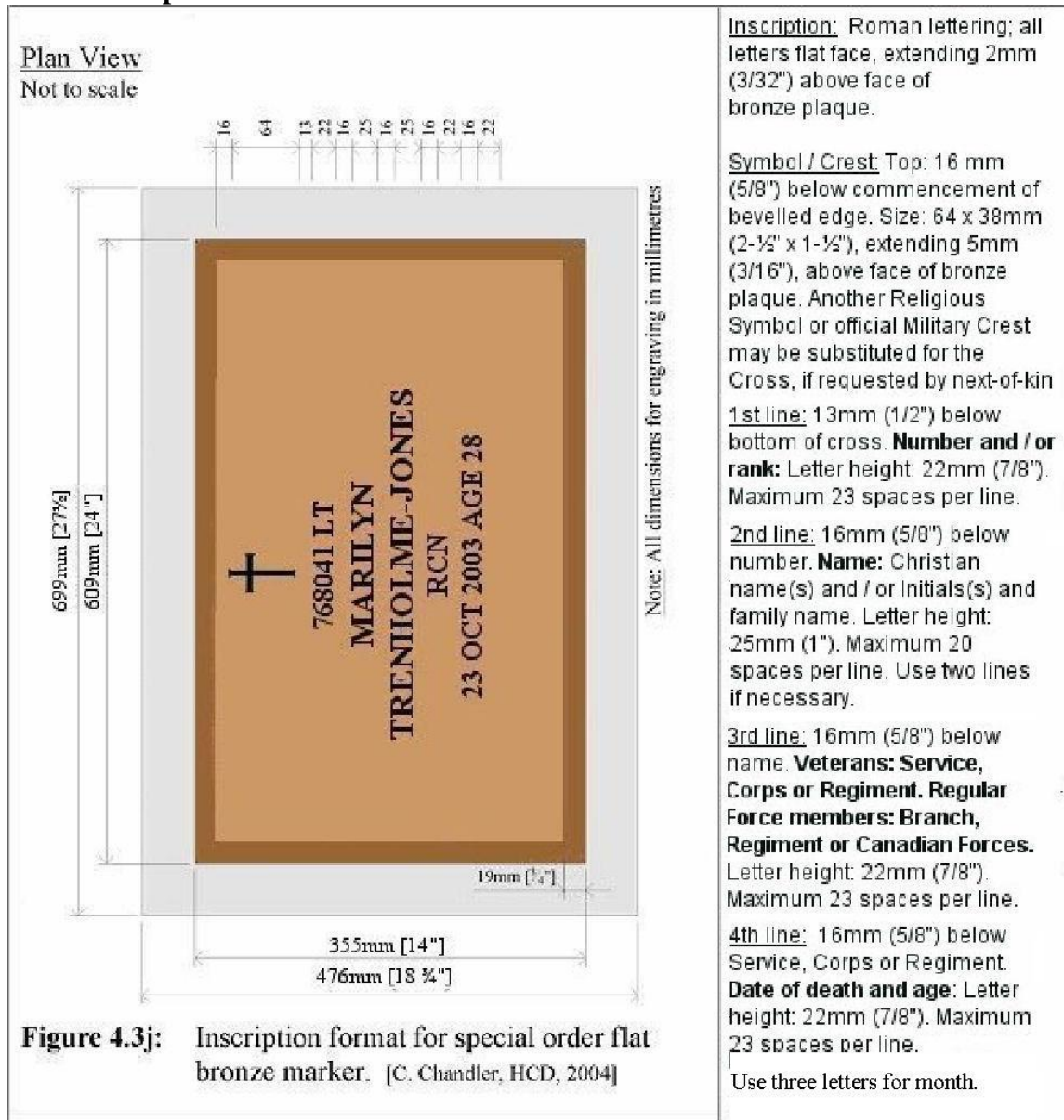

Figure 4.3i: Inscription format for DND flat granite markers. [C. Chandler, HCD, 2004]

4.3.11 Inscription Format for DND Flat Bronze Markers



4.3.12 Inscription Format for DND Cremation Markers

While the forms for DND cremation markers can follow individual cemetery specifications, their inscriptions should adhere to the specifications below:

Cross: If space permits.

- 1st line: Service personnel's name and awards if any.
- 2nd line: Awards, if need be, and rank.
- 3rd line: Rank, if need be, and unit.
- 4th line: Definitely containing years of birth and death.

4.3.13 Spousal Commemoration

VAC recognizes that the commemoration of spouses at the same gravesite is a common practice within Canada. To accommodate this custom VAC recommends that in response to family wishes, a veteran's spouse may be commemorated by means of a foot marker at the gravesite.

The specifications for the spousal commemoration are as follows:

- The size of the foot marker is to be 500 x 300 x 100mm (20" x 12" x 4").
- Material for the foot marker is to match the veteran's marker as to type of granite (Stanstead or Barre), or bronze on granite.
- Inscription to employ the same font used in the veteran's marker, whether Smith Sip No. 2 or Monu-Cad No. 69 with no highlighting of letters.
- Inscribing by sandblast process letters to be V-sunk, or by hand, to a minimum depth of 6mm (1/4").
- If a foot marker is not permissible by the cemetery authority, commemoration by another appropriate and dignified means, acceptable to the family/next of kin, VAC and the cemetery authority is possible. The instrument that commemorates the spouse/common-law partner should not detract or overshadow the eligible person's grave marker.
- If the commemoration inscription is to be on the existing grave marker the font size may be smaller than 25mm (1").

4.4 Grave Marker Foundations

Mounting a grave marker onto its foundation, as part of the installation process requires that three topics be considered: the foundation type (which includes consideration of soil type), the materials for the foundation and its installation, and the methods and materials for connecting the grave marker to the foundation. **Section 4.4.1** presents the recommended types of new grave marker foundations with their standards. **Section 4.4.2** presents the standards for the materials used to fabricate and install these foundations, and **Section 4.4.3** presents the standards for connecting the grave markers to their foundations.

4.4.1 Foundation Types

Three standard foundation types are recommended:

- single marker foundation pad,
- multiple marker beam-on-grade foundation, and
- multiple marker beam-on-pier foundation.

The selection of the foundation type for installation should be based on the type of soils present, the number and arrangement of markers to be installed, and whether the installation is a new installation or a restoration of an existing installation. The most appropriate emplacement method, buried or exposed, also needs to be considered for each type of foundation.

Deciding on the Foundation Type

Single marker foundation pads are appropriate in instances where the marker is isolated from other VAC markers. In this type of foundation, a reinforced concrete pad, solid granite block, or a compacted bed of granular fill spreads the weight of the marker over the soil and provides resistance against overturning of upright markers.

In general, single marker foundation pads should only be used when ongoing soil movement is not a problem, as for example, when the soil type is a free draining coarse soil or a free draining sandy soil. On-going movements in other soils will eventually shift a marker on this type of foundation out of alignment. Grave settlement will also typically be more pronounced in sandy, granular, non-cohesive soils and a single marker foundation pad used in this instance may shift out of vertical alignment as a result. When such misalignment does occur, however, the foundation and marker assembly can be re-leveled as a unit. The cost-benefit analysis for installing a group of single marker foundation pads versus installing a multiple marker foundation should thus include consideration for the soil conditions and the cost and effort involved in future re-leveling of markers on single foundations.

Multiple marker foundations are recommended in instances where there is a grouping of markers being installed, as for example within a Field of Honour. In this type of foundation, markers are supported in a line by a continuous reinforced concrete beam. The beam can be supported on a compacted layer of granular fill or on concrete or steel piers, which have been driven or cast into the soil.

Multiple marker beam-on-grade foundations utilize a continuous reinforced concrete beam supported on a compacted layer of granular fill. Beam-on-grade foundations are best suited for soils that are composed of reasonably free draining coarse or sandy materials. When used on soils that are highly organic, such as peat or organic silt, or soils that contain clays or fill material, a beam-on-grade foundation may eventually become misaligned as a result of soil movements. However this situation can be addressed to some degree through the design of the granular base for the foundation. Beam-on-grade foundations have been installed on highly organic soils in the past and have performed satisfactorily for ten or more years.

Multiple marker beam-on-pier foundations utilize a continuous reinforced concrete beam supported on concrete or steel piers, which have been driven or cast into the soil. Beam-on-pier foundations are best suited for use when restoring an existing beam-on-grade installation that has experienced on-going undesirable soil movements. In some situations, where local conditions warrant, a beam-on-pier foundation may be appropriate for use with a new installation. This includes situations where soil conditions are such that considerable beam-on-grade movement can be expected over a short time period.

The decision to install a beam-on-pier foundation in place of a beam-on-grade foundation should include a cost benefit analysis of the two foundation types. Because of the work involved in driving or casting piers, a beam-on-pier foundation is typically considerably more expensive than a beam-on-grade foundation. This premium in cost becomes less of a factor when large numbers of foundations are being installed as the mobilization costs involved in constructing the piers become less significant relative to the total cost of the work. Beam-on-pier foundations may also require access for large equipment for drilling the pier holes or driving the piers into the ground, and the impact and feasibility of bringing such equipment into the cemetery must be considered.

Emplacement Method

Marker foundations can be buried or exposed, and the decision to bury or expose should be based on a consideration of several factors, including:

- original design intent for the cemetery landscape,
- evolution of the site or previous practice at the cemetery,
- topography of the cemetery, and
- type and number of markers.

In evaluating the suitability of an exposed foundation, consideration should be given to the fact that exposing or raising the foundation above the grave surface has the benefit of reducing the risk of accidental damage to the markers from impacts with maintenance equipment as cutting the turfgrass right against the marker is eliminated. This can also reduce the time spent on mowing, and the need to water the turfgrass during dry periods.

Single Foundation Pads for Upright Granite Markers

The preferred foundation for single upright markers is the Commonwealth War Graves Commission foundation (see next two pages) and the second preferred option is a reinforced concrete pad supported by a prepared base of new free draining granular fill. Figure 4.4a (i), 4.4a (ii), and 4.4a (iii), below, detail the recommended installation procedure and the pads dimensions and reinforcement. If the emplacement is to be an exposed foundation, extra care must be taken in providing a proper finish to all of the exposed concrete surfaces.

Commonwealth War Graves Commission Foundation (Note: This is different than an LPF/VAC foundation)

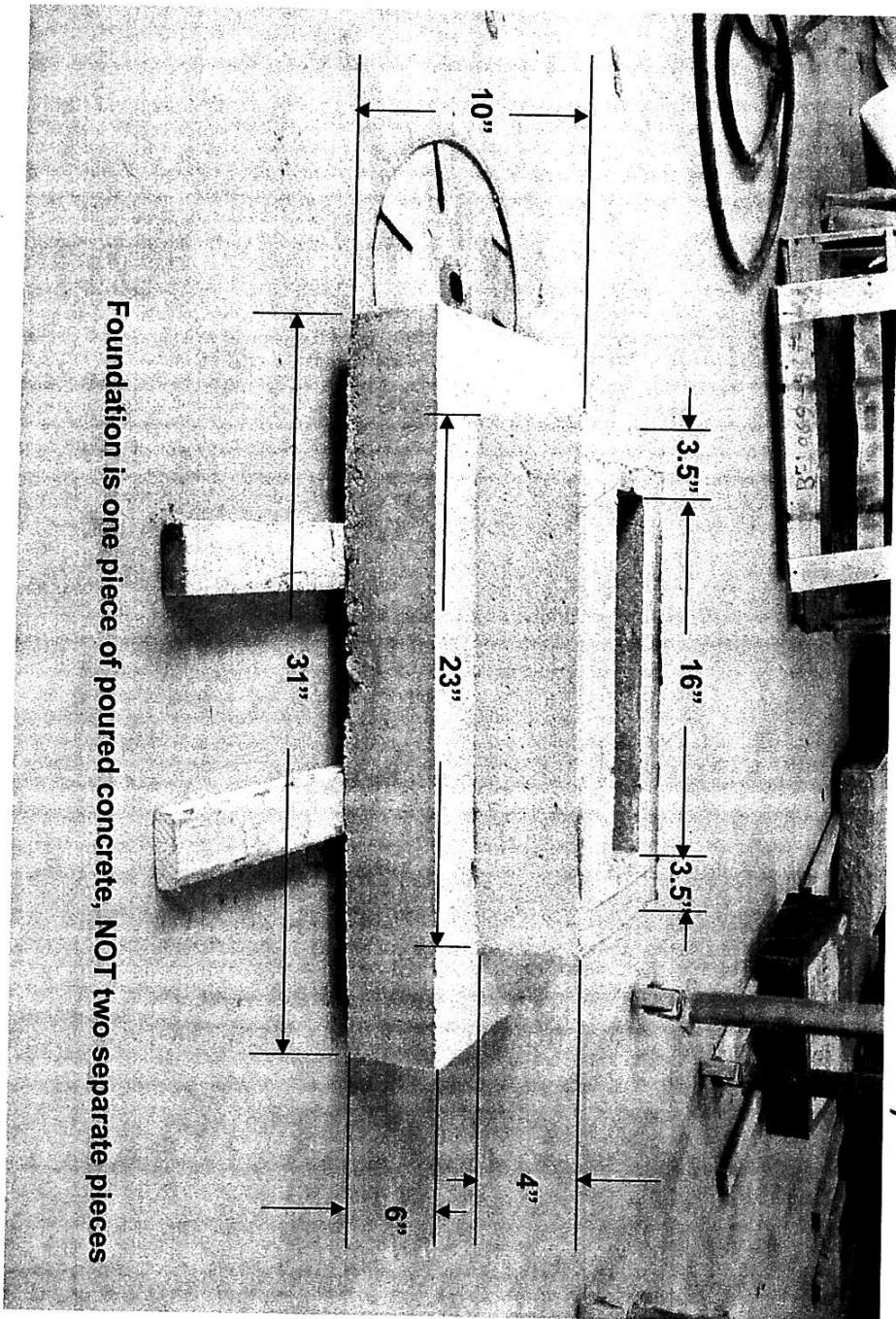

Foundation is one piece of poured concrete, NOT two separate pieces

Commonwealth War Graves Commission Foundation

(Note: This is different than an LPF/VAC foundation)

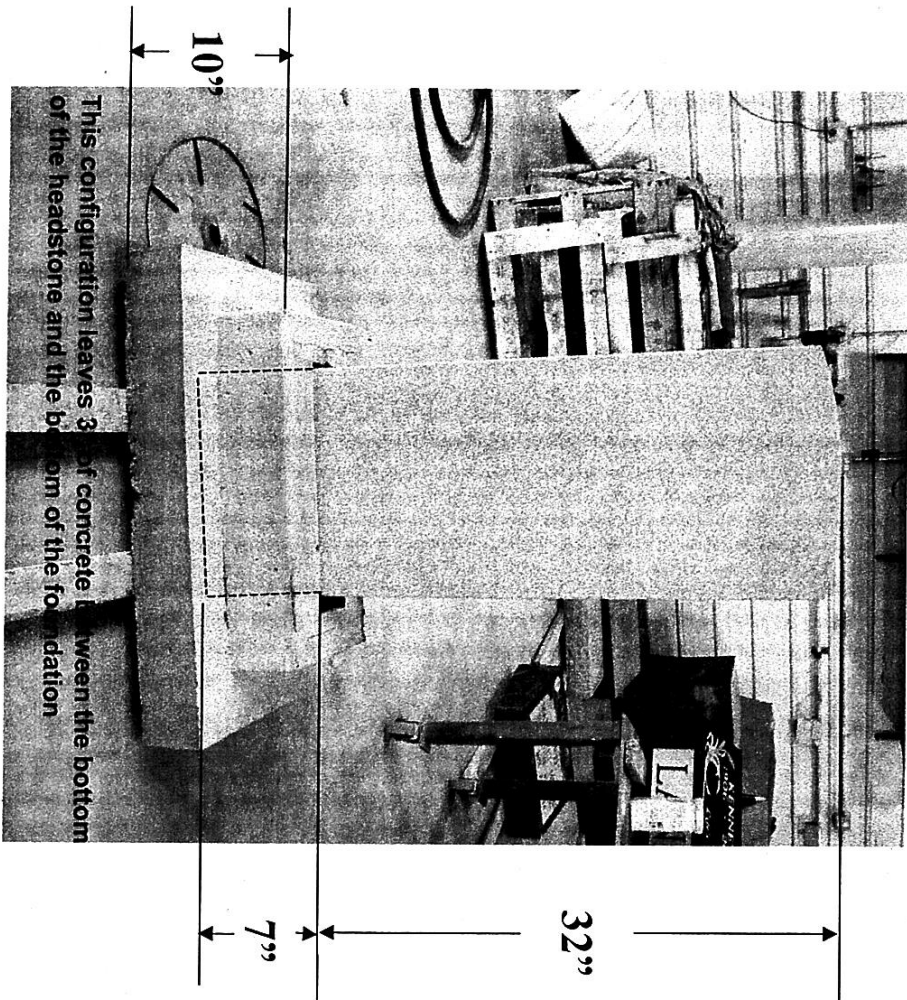

Exposed Emplacement

Not to scale

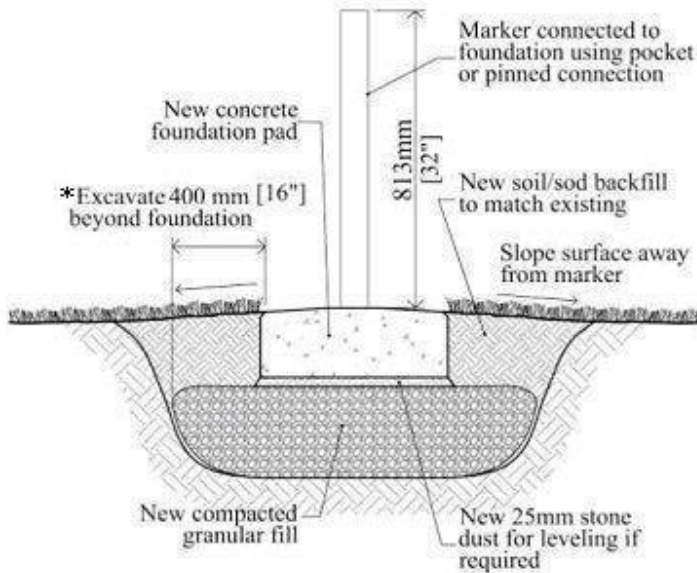

Buried Emplacement

Not to scale

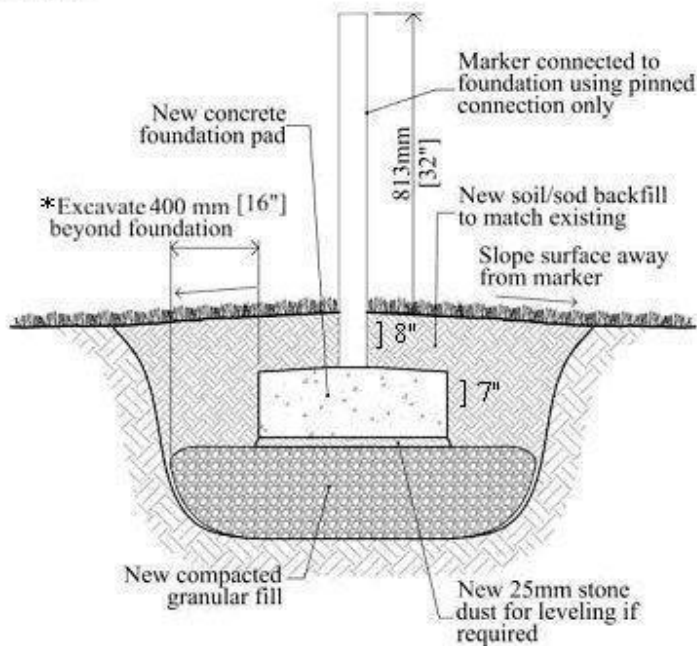

Figure 4.4a (i): Single foundation for upright marker
[C. Chandler, HCD, 2004].

Materials for Installation:

Reinforced concrete foundation pad. Refer to drawings 4.4a(ii) and (iii) for pad construction details.

New granular fill. For depth of new fill and compaction requirements refer to Section 4.4.2.

Wrap new granular fill in geotextile fabric, overlap joints 200mm minimum.

Use limestone screenings for stone dust.

Re-use existing sod or grave surface if suitable, otherwise provide new to match existing.

* Width of excavation for marker installation may be reduced to a minimum of 100 mm (4") on either side of the marker to avoid disruption to adjacent graves and to stay within grave boundaries.

**For Buried Emplacement marker length is 1016 mm (40") or more if necessary.

Axonometric view

Not to scale

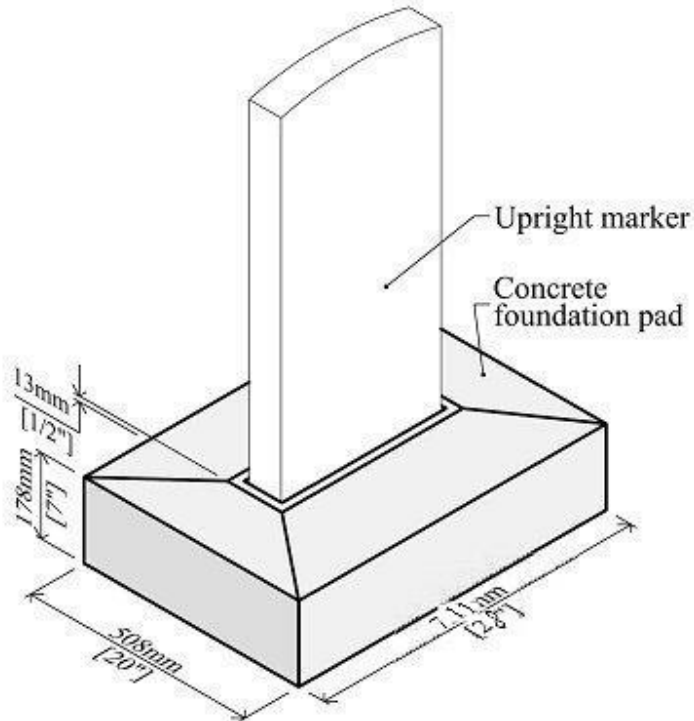

Figure 4.4a (ii): Single foundation for upright marker
 [C. Chandler, HCD, 2004].

Materials for Installation:

Reinforced concrete foundation pad. Refer to drawings 4.4a(iii) for pad construction and reinforcement details.

The exception to the size of the marker would be in replacing the marker within an existing row, where the base size would cause the new marker's centre to be out of alignment with other markers in that row.

Dimensions and Reinforcement

Not to scale

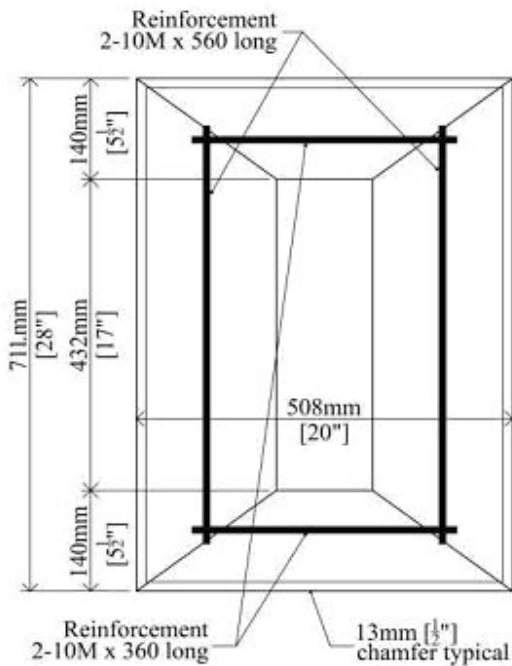
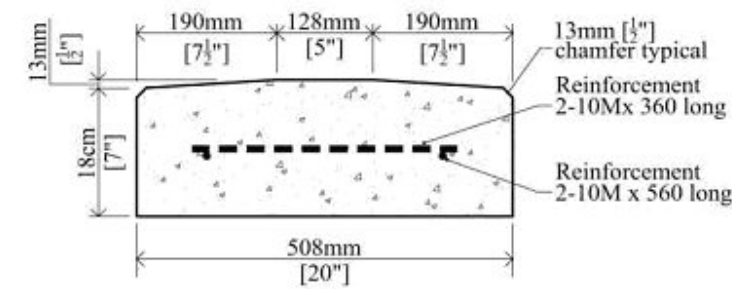

Figure 4.4a (iii): Single foundation for upright marker
[C. Chandler, HCD, 2004].

Materials for Installation:

Concrete to match specifications in Section 4.4.2 to match soil conditions of the site.

Reinforcement to match specifications in Section 4.4.2.

13mm [1/2"] chamfer not necessary for buried emplacements.

For markers with 6" thickness to meet some Ontario Cemetery requirements:

1. Increase the width of the flat ledge on top of the pad from 127mm [5"] to 203mm [8"].

Single Foundation Pads for Flat Granite Markers The preferred foundation for a single flat marker is a solid granite block supported on a prepared base of new free draining granular fill. Figure 4.4b (i) below, details the foundation block's dimensions.

An alternative to the granite block foundation, for installations where the face of the marker is set flush with the grave surface, involves setting the marker on a bed of compacted granular fill only, with no intermediate granite block foundation pad. This alternative installation is also suitable for instances where existing flat markers are being re-set.

Figure 4.4b (ii) details the emplacement methods for both foundation types.

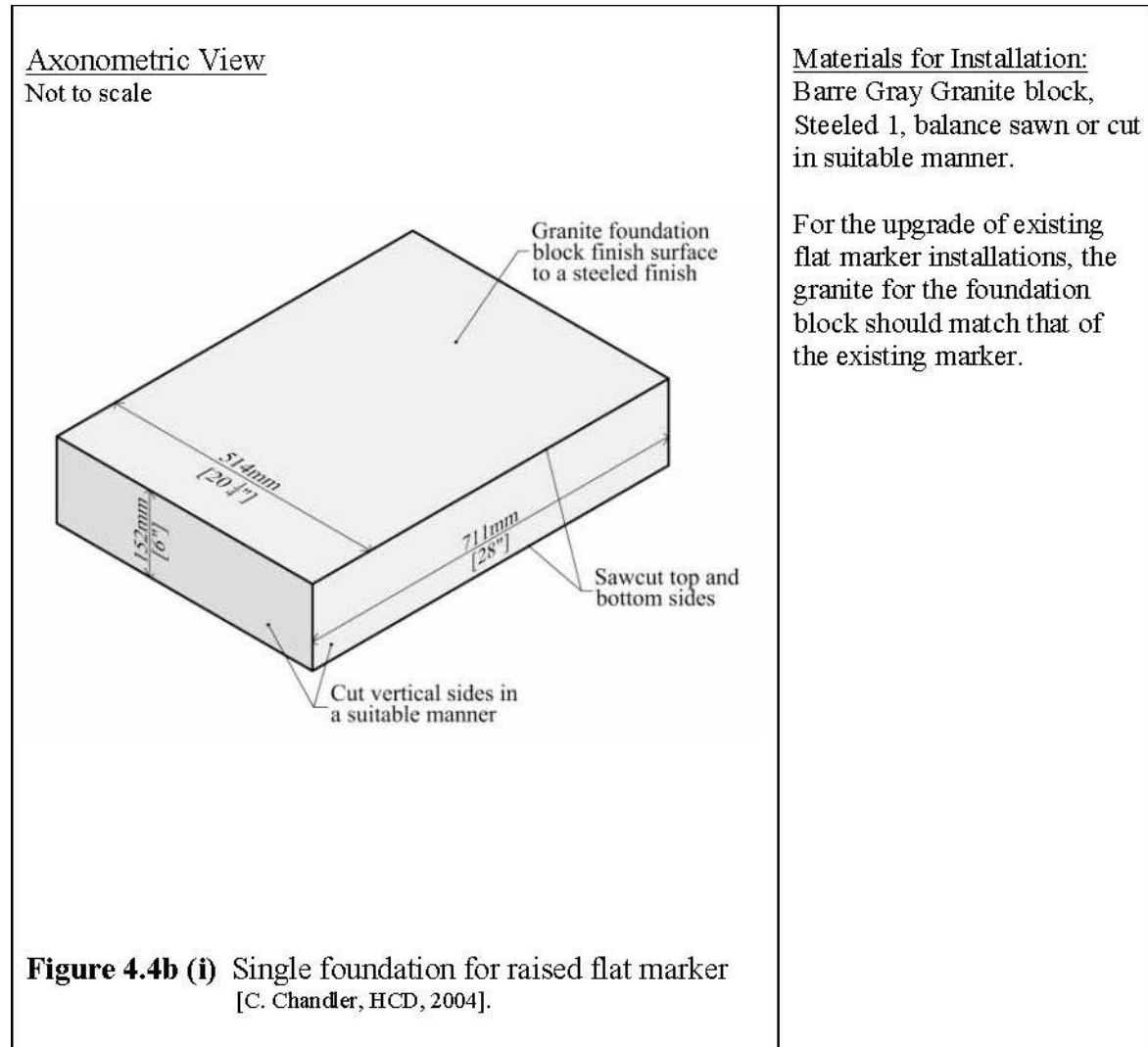

Emplacement With Granite Block Foundation

Not to scale

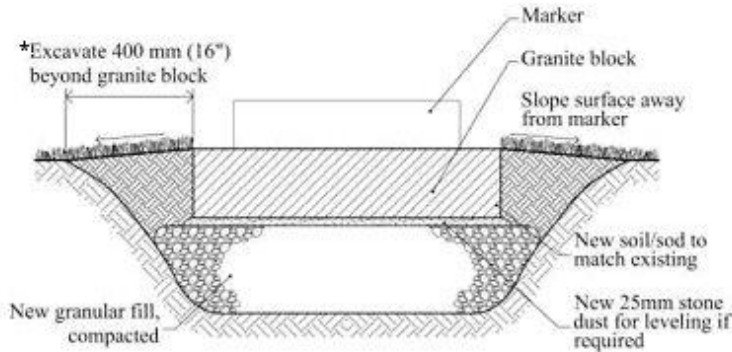

Emplacement With Compacted Granular Fill Foundation

Not to scale

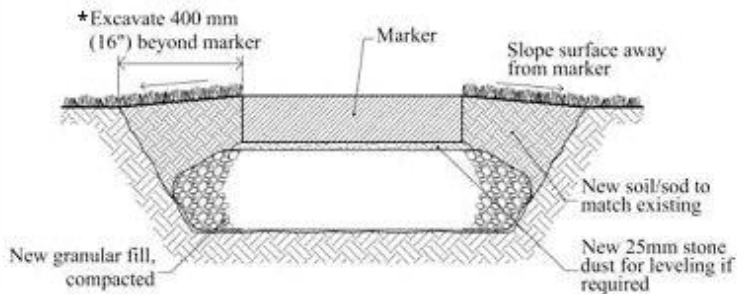

Figure 4.4b (ii) Single foundation for flat marker.
[C. Chandler, HCD, 2004].

Materials for Installation:
Barre Gray Granite block,
Steeled 1, balance sawn or cut
in suitable manner.

For the upgrade of existing
flat marker installations, the
granite for the foundation
block should match that of
the existing marker.

New granular fill. For depth
of new fill and compaction
requirements refer to Section
4.4.2.

Wrap new granular fill in
geotextile fabric, overlap
joints 200mm minimum.

Use limestone screenings for
stone dust.

Re-use existing sod or grave
surface if suitable, otherwise
provide new to match
existing.

* Width of excavation for
marker installation may be
reduced to a minimum of
100 mm (4") on either side
of the marker to avoid
disruption to adjacent graves
and to stay within grave
boundaries.

pillow,
ngle
ions

Axonometric View

Not to scale

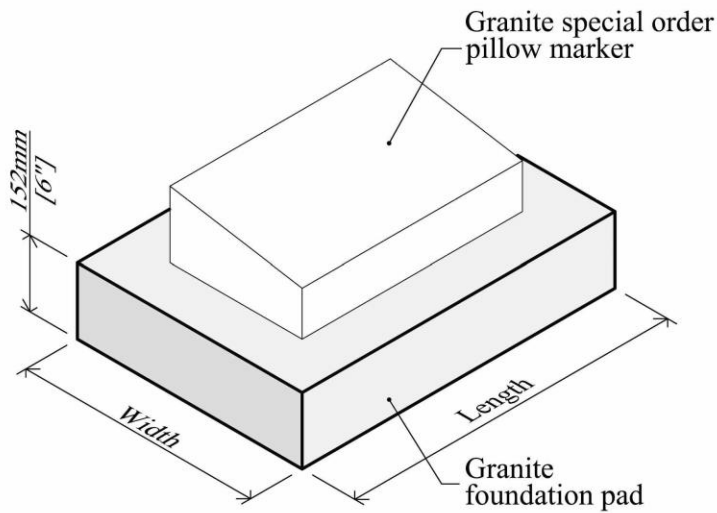

Figure 4.4c(i): Single foundation for special order marker [C. Chandler, HCD, 2004].

Dimensions of Granite Block:

Pillow Marker

Width: 562mm [22-1/8"]

Length: 930mm [36-5/8"]

Bronze Marker

Width: 679mm [26-3/4"]

Length: 902mm [35-1/2"]

Materials for Installation:

Barre Gray Granite block,
Steeled 1, balance sawn or cut
in suitable manner.

For the upgrade of existing flat
marker installations, the
granite for the foundation
block should match that of the
existing marker.

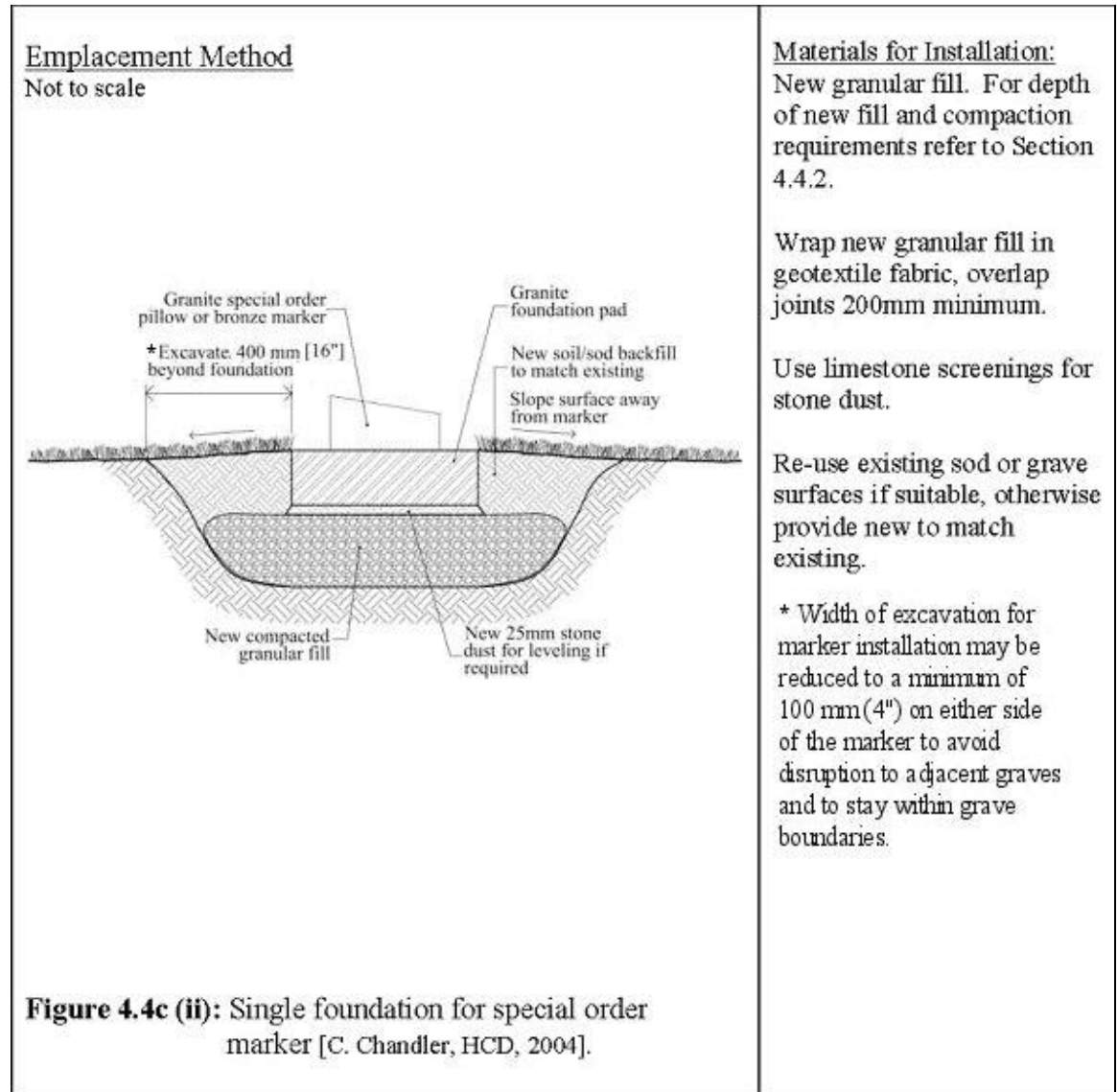

Beam-on-Grade Foundation for Multiple Upright Markers

The preferred foundation for multiple upright markers is a reinforced concrete beam-on-grade foundation on a prepared base of new free draining granular fill. The dimensions of the foundation beam are the same for both buried and exposed emplacement conditions. Figure 4.4d (i) details the recommended installation procedures. If the emplacement is to be an exposed foundation, extra care must be taken in providing a high quality finish to all of the exposed faces of the concrete surfaces. Figure 4.4d (ii) details the dimensions of the beam and treatment between adjoining foundation beams. Figure 4.4d (iii), details the dimensions and reinforcement of the concrete beam.

Exposed Emplacement

Not to scale

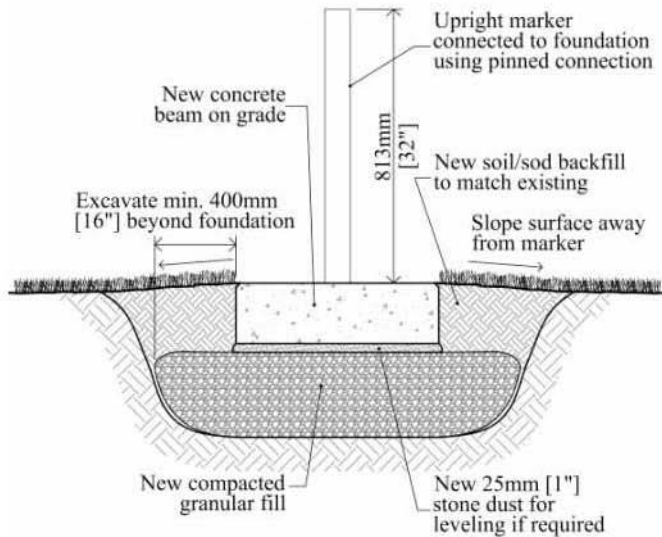

Buried Emplacement

Not to scale

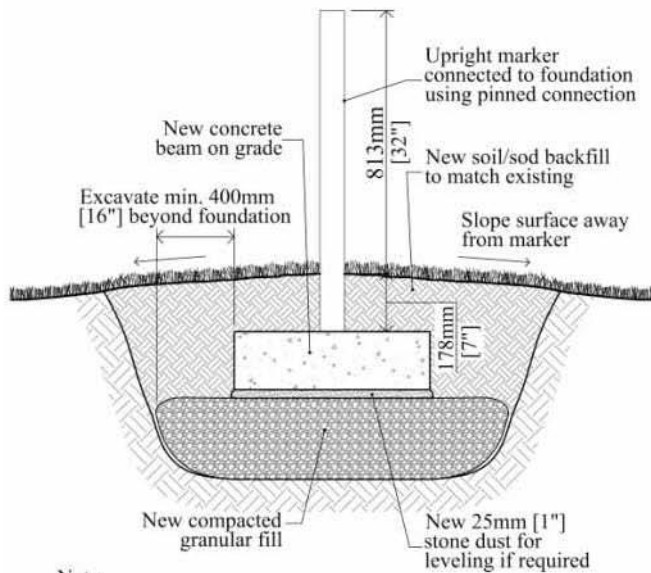

Note:
Grouted pocket connections are not suitable for this installation type

Figure 4.4d (i): Beam-on-grade foundation for multiple upright markers [C. Chandler, HCD, 2004]

Materials for Installation:

Reinforced concrete beam.
Refer to drawing 4.4d (ii) and (iii) for beam dimensions and details.

New granular fill. For depth of new fill and compaction requirements refer to Section 4.4.2.

Wrap new granular fill in geotextile fabric, overlap joints 200mm minimum.

Use limestone screenings for stone dust.

Re-use existing sod or grave surfaces if suitable, otherwise provide new to match existing.

Axonomic View

Not to scale

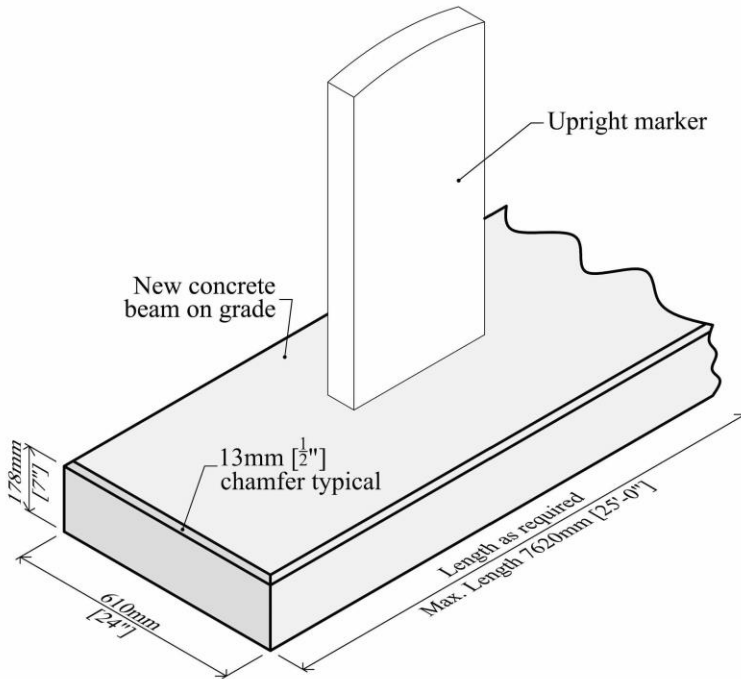

Materials for Installation:

Concrete to match specifications in Section 4.4.2 to match soil conditions of the site.

Reinforcement to match specifications in Section 4.4.2.

13mm [1/2"] chamfer not necessary for buried emplacement.

Cross Section and Reinforcement

Not to scale

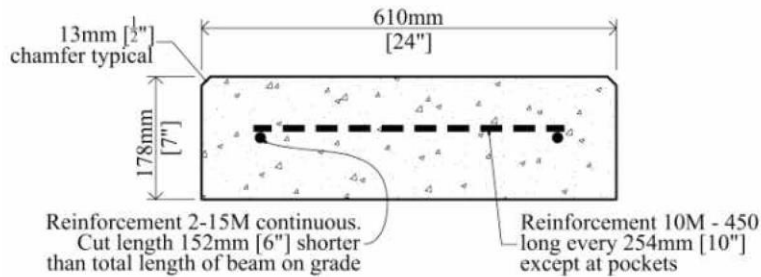
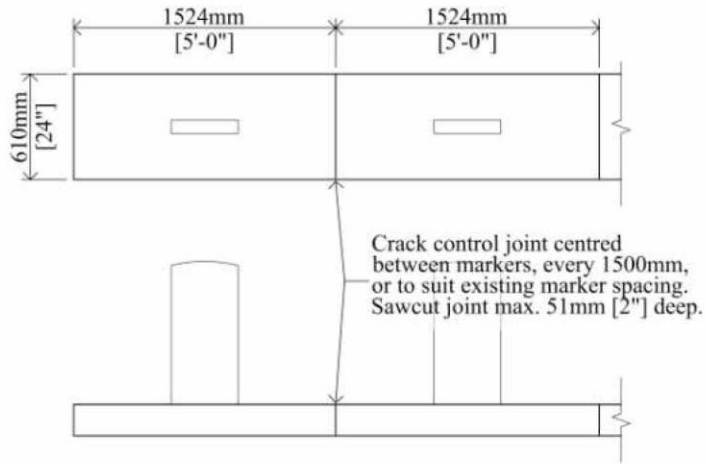

Figure 4.4d (ii): Beam-on-grade foundation for multiple upright markers [C. Chandler, HCD, 2004]

Beam Dimensions

Not to scale



Detail at Joint between Beams

Not to scale

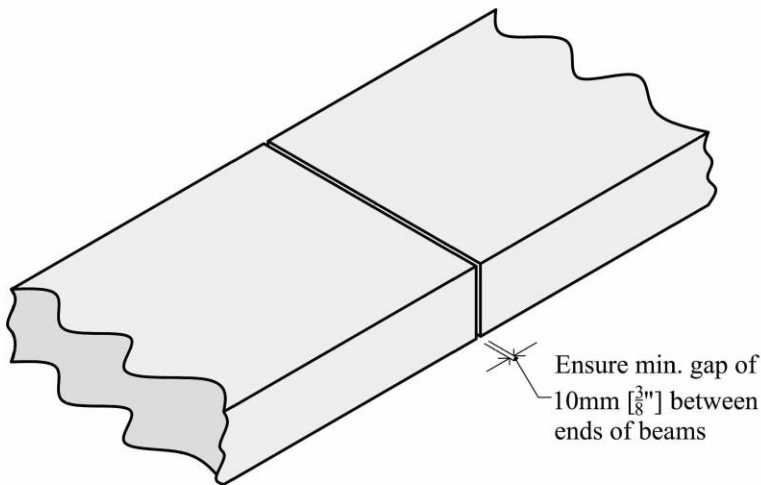

Figure 4.4d (iii): Beam-on-grade foundation for multiple upright markers [C. Chandler, HCD, 2004].

Materials for Installation:

Concrete to match specifications in Section 4.4.2 to match soil conditions of the site.

Reinforcement to match specifications in Section 4.4.2.

Beam-on-Grade Foundation for Multiple Flat Markers and Multiple Special Order Markers

The preferred foundation for multiple flat markers is a reinforced concrete beam-on-grade foundation supported by a prepared base of new free draining granular fill. The dimensions and shape of the foundation beam will differ depending on whether the foundation beam is to be buried or exposed. In the case of an exposed emplacement, the installation procedure and concrete beam dimensions and reinforcement are detailed in Figure 4.4e (i), (ii), (iii), and (iv) below.

In the case of a buried emplacement, the concrete beam dimensions, reinforcing, and installation procedures differ significantly. Furthermore, in a buried beam emplacement there are two options to consider for placement of the marker: the entire marker is raised above the turfgrass on a concrete pad, or the face of the marker is set flush with the turfgrass. The raised marker is the preferred installation for minimizing damage to the markers from mowing operations and the foundation beam is detailed in Figure 4.4f (i), (ii), (iii), and (iv) below. The foundation beam for buried emplacement, where the marker is flush with the turfgrass, is detailed in Figure 4.4g (i), (ii), (iii), and (iv) below.

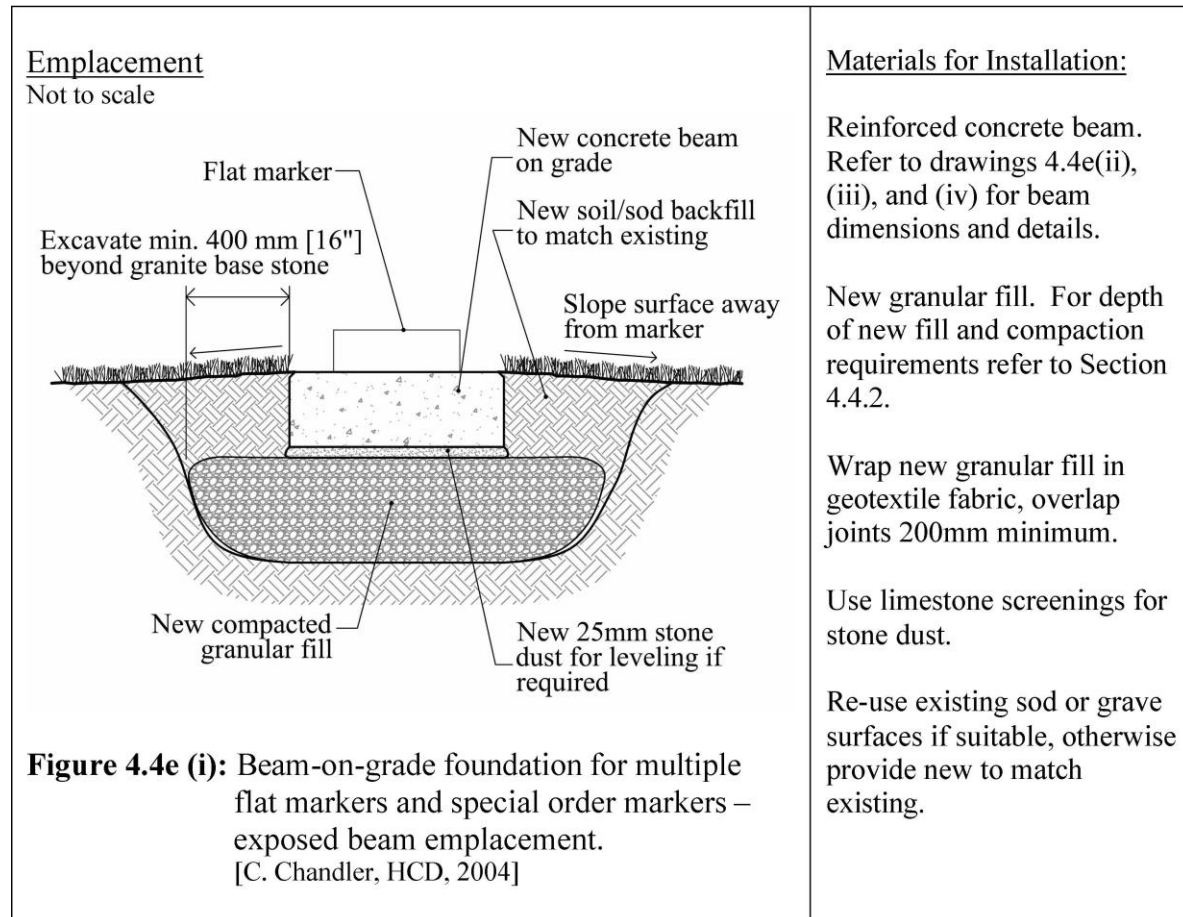

Axonomic View

Not to scale

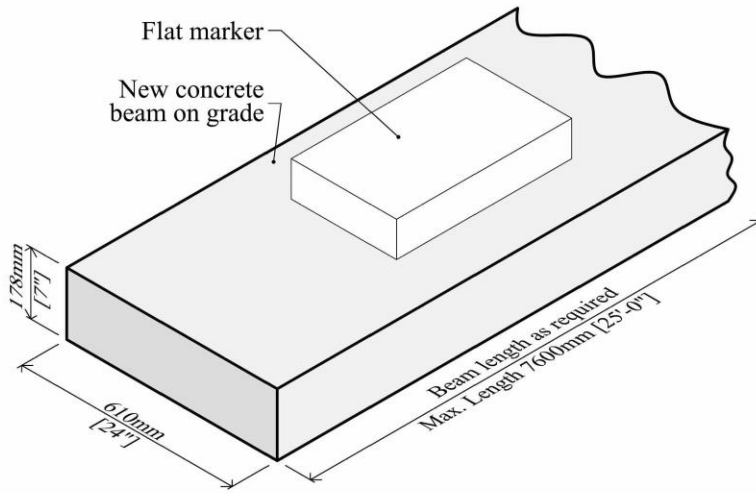

Materials for Installation:

Concrete to match specifications in Section 4.4.2 to match soil conditions of the site.

Reinforcement to match specifications in Section 4.4.2.

Beam Reinforcement

Not to scale

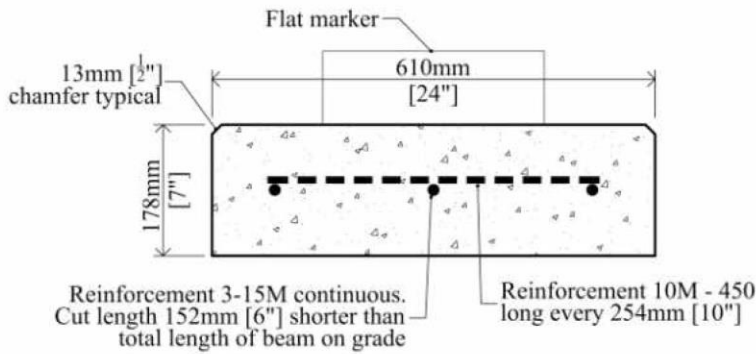
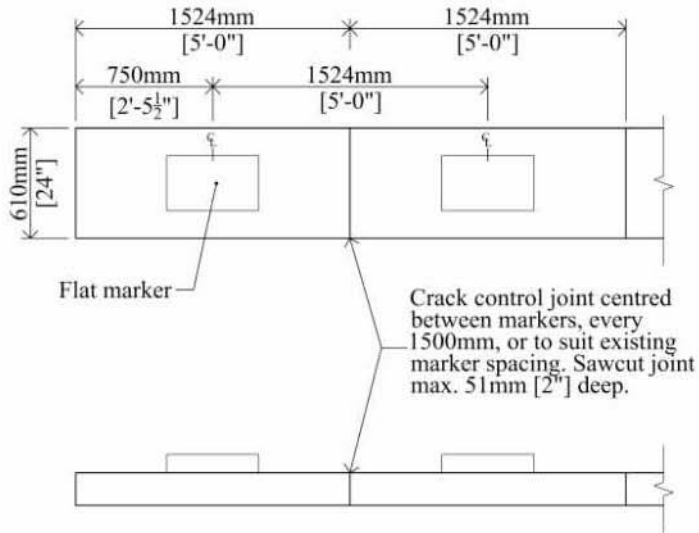

Figure 4.4e (ii): Beam-on-grade foundation for multiple flat markers and special order markers – exposed beam emplacement.
[C. Chandler, HCD, 2004]

Beam Dimensions

Not to scale



Materials for Installation:

Concrete to match specifications in Section 4.4.2 to match soil conditions of the site.

Reinforcement to match specifications in Section 4.4.2.

Figure 4.4e (iii): Beam-on-grade foundation for multiple flat markers and special order markers – exposed beam emplacement.
[C. Chandler, HCD, 2004]

Detail at Joint Between Beams

Not to scale

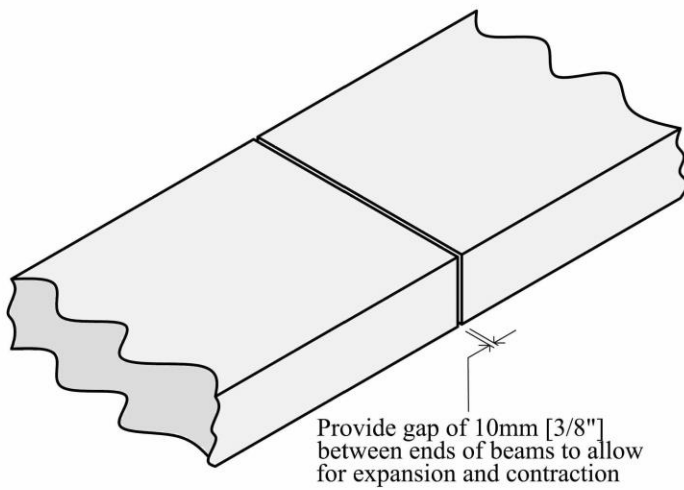

Figure 4.4e (iv): Beam-on-grade foundation for multiple flat markers and special order markers – exposed beam emplacement.
[C. Chandler, HCD, 2004]

Materials for Installation:

Place 10mm thick fibreboard in joint to prevent joint from filling with debris.

Emplacement

Not to scale

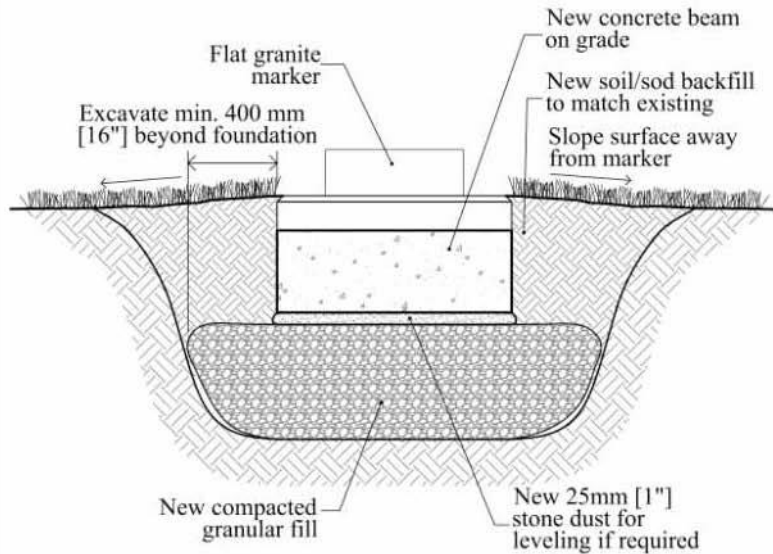

Beam Reinforcement

Not to scale

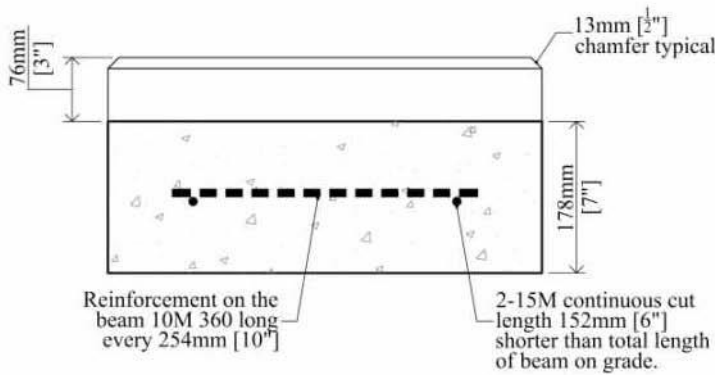

Figure 4.4f (i): Beam-on-grade foundation for flat markers and special order markers – buried emplacement marker raised above turfgrass [C. Chandler, HCD, 2004].

Materials for Installation:

Reinforced concrete beam. Refer to drawings 4.4f (ii), (iii), and (iv) for beam dimensions and details.

New granular fill. For depth of new fill and compaction requirements refer to Section 4.4.2.

Wrap new granular fill in geotextile fabric, overlap joints 200mm minimum.

Use limestone screenings for stone dust.

Re-use existing sod or grave surfaces if suitable, otherwise provide new to match existing.

Concrete to match specifications in Section 4.4.2 to match soil conditions of the site.

Reinforcement to match specifications in Section 4.4.2.

Axonometric View

Not to scale

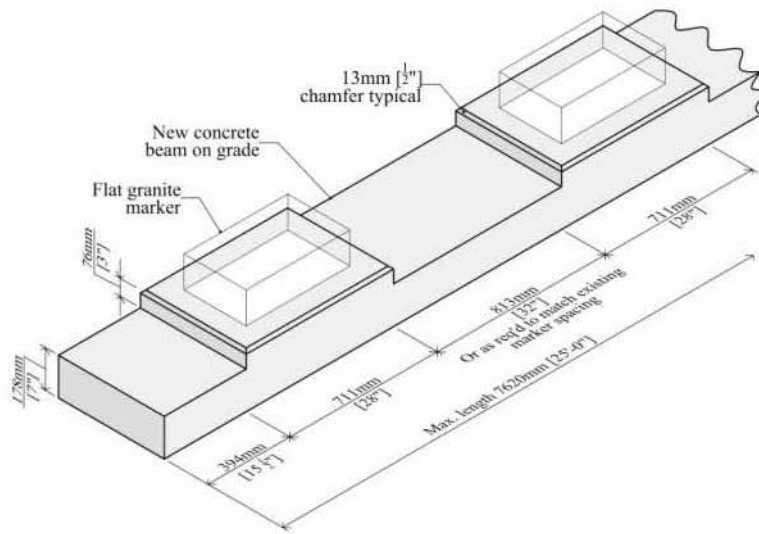

Materials for Installation:

Concrete to match specifications in Section 4.4.2 to match soil conditions of the site.

Reinforcement to match specifications in Section 4.4.2.

Figure 4.4f (ii): Beam-on-grade foundation for flat markers and special order markers – buried emplacement marker raised above turfgrass [C. Chandler, HCD, 2004].

Beam Dimensions

Not to scale

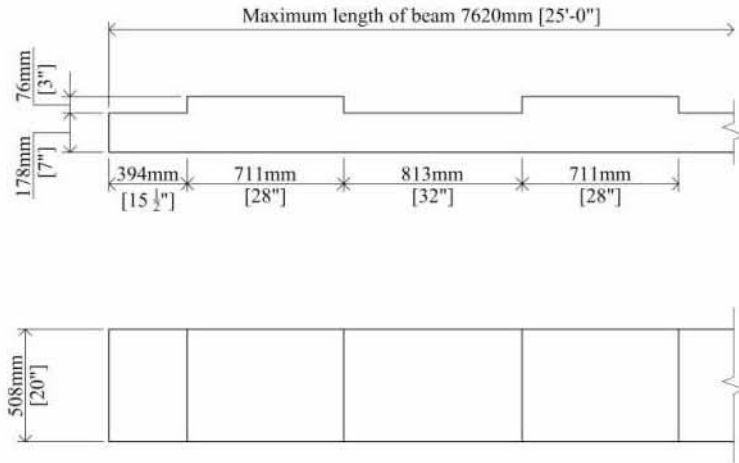

Materials for Installation:

Concrete to match specifications in Section 4.4.2 to match soil conditions of the site.

Reinforcement to match specifications in Section 4.4.2.

Dimensions for Special Order Markers:

Pillow Marker

Width of Beam: 562mm [22-1/8"]

Length of Upstand: 930mm [36-5/8"]

Bronze Marker

Width of Beam: 679mm [26-3/4"]

Length of Upstand: 902mm [35-1/2"]

Longitudinal Reinforcement for Special Order Bronze Markers:

Increase reinforcement to 2-15M continuous.

Figure 4.4f (iii): Beam-on-grade foundation for flat markers and special order markers – buried emplacement marker raised above turfgrass [C. Chandler, HCD, 2004].

Detail at Joint Between Beams

Not to scale

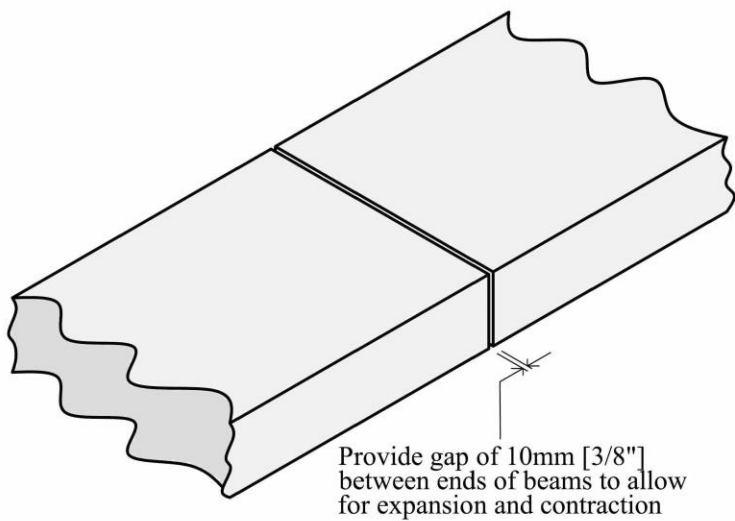

Materials for Installation:

Place 10mm thick fibreboard in joint to prevent joint from filling with debris.

Figure 4.4f (iv): Beam-on-grade foundation for flat markers and special order markers – buried emplacement marker raised above turfgrass [C. Chandler, HCD, 2004].

Emplacement

Not to scale

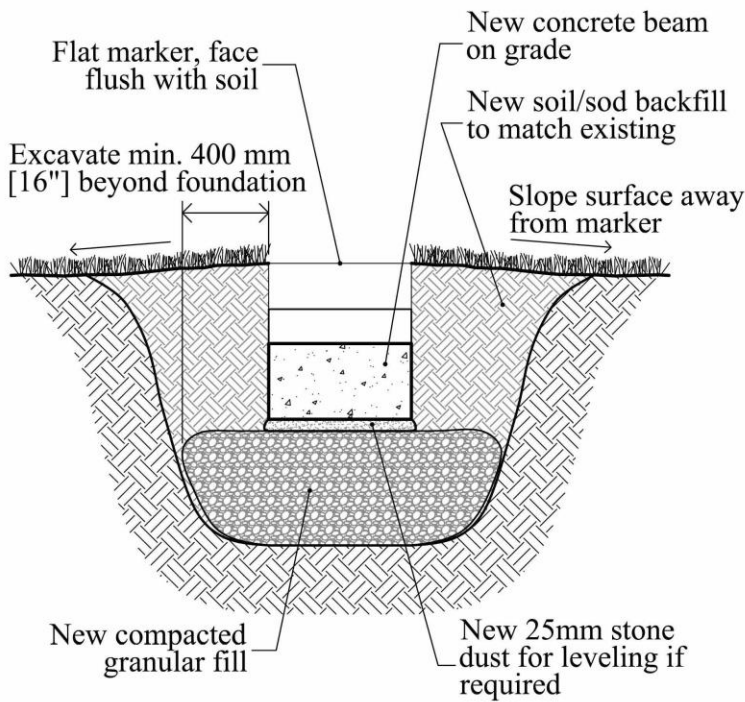

Beam Reinforcement

Not to scale

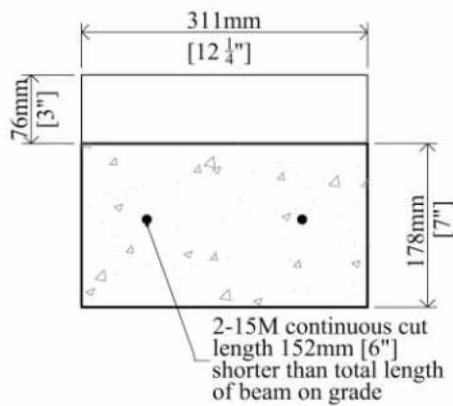

Figure 4.4g (i): Beam-on-grade foundation for flat markers and special order markers – buried emplacement marker flush with turfgrass [C. Chandler, HCD, 2004].

Materials for Installation:

Reinforced concrete beam. Refer to drawings 4.4g (ii), (iii), and (iv) for beam dimensions and details.

New granular fill. For depth of new fill and compaction requirements refer to Section 4.4.2.

Wrap new granular fill in geotextile fabric, overlap joints 200mm minimum.

Use limestone screenings for stone dust.

Re-use existing sod or grave surfaces if suitable, otherwise provide new to match existing.

Concrete to match specifications in Section 4.4.2 to match soil conditions of the site.

Reinforcement to match specifications in Section 4.4.2.

Axonometric View

Not to scale

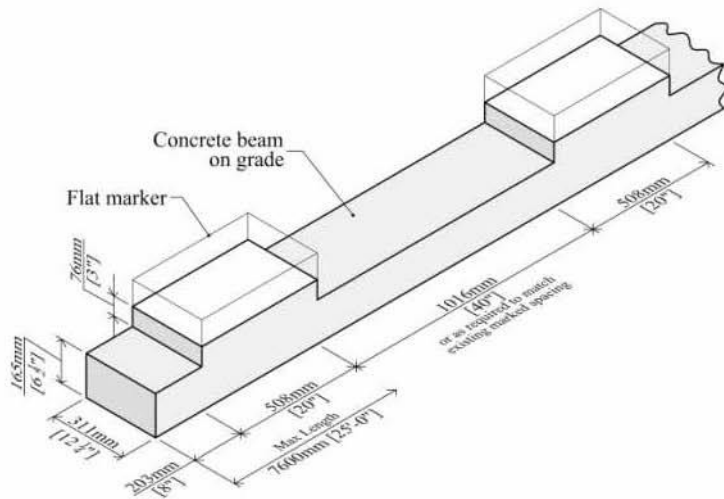

Figure 4.4g (ii): Beam-on-grade foundation for flat markers and special order markers – buried emplacement marker flush with turfgrass [C. Chandler, HCD, 2004].

Materials for Installation:

Concrete to match specifications in Section 4.4.2 to match soil conditions of the site.

Reinforcement to match specifications in Section 4.4.2.

Beam Dimensions

Not to scale

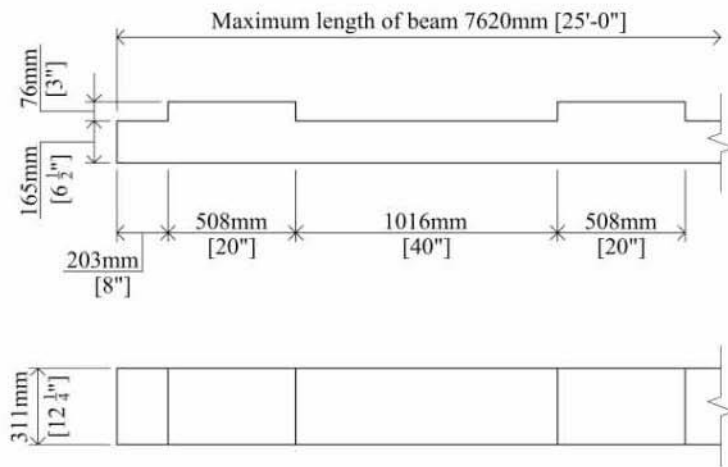

Figure 4.4g (iii): Beam-on-grade foundation for flat markers and special order markers – buried emplacement marker flush with turfgrass [C. Chandler, HCD, 2004].

Materials for Installation:

Concrete to match specifications in Section 4.4.2 to match soil conditions of the site.

Reinforcement to match specifications in Section 4.4.2.

Dimensions for Special Order Markers:

Bronze Marker

Width of Beam: 476mm [18-3/4"]

Length of Upstand: 699mm [27-1/2"]

Detail at Joint Between Beams

Not to scale

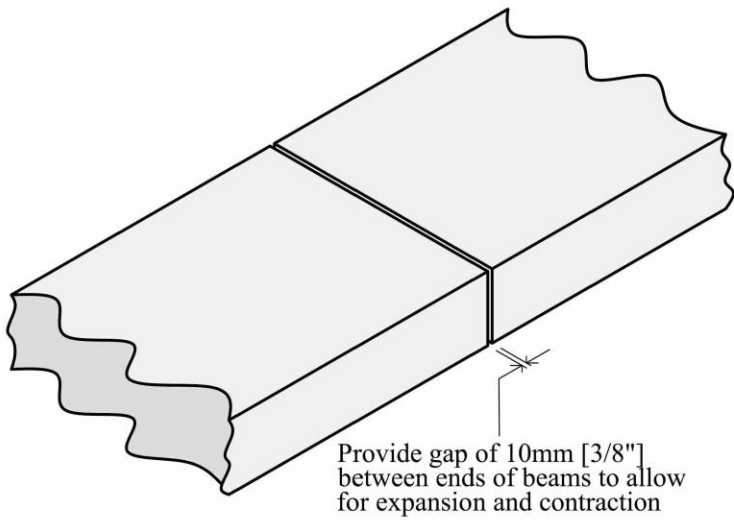

Materials for Installation:

Place 10mm thick fibreboard in joint to prevent joint from filling with debris.

Figure 4.4g (iv): Beam-on-grade foundation for flat markers and special order markers – buried emplacement marker flush with turfgrass [C. Chandler, HCD, 2004].

Beam-on-Pier Foundations for Multiple Upright, Flat and Special Order Markers

The preferred foundation for multiple markers where beam-on-grade foundations are known to not perform satisfactorily, or where soil conditions are such that considerable beam-on-grade foundation movement can be expected over a short time period, is a reinforced concrete beam-on-pier foundation.

The design of this type of foundation system requires consideration for the unique specific site conditions present, including the length of the beam, the number and location of the piers, and the soil type. The following general standards are the basis for the design of this type of foundation; however, specialist professional engineering advice must be obtained to complete the design of the reinforcing and the foundation piles.

The recommended shape of the concrete beam for upright, flat and special order markers, with an exposed emplacement, and for upright markers with a buried emplacement is similar to the beam-on-grade foundation detailed in Figure 4.4d, above.

The recommended shape of the concrete beam for flat markers and special order markers with a buried emplacement is similar to the beam-on-grade foundations detailed in Figure 4.4f and 4.4g, above.

The only difference between the dimensions of the beam-on-grade foundations illustrated previously and the beam-on-pier foundations should be the thickness of the beam, which may need to be increased beyond the thickness shown to increase the beams strength and stiffness. The width of the beam should not be increased as a way of increasing its strength. The strength of the concrete mix may also need to be adjusted to achieve the required beam strength and any revisions to the standard mix design should match it in terms of durability.

If the emplacement is to be an exposed foundation, extra care must be taken in providing a proper finish to all of the exposed faces of the beam.

4.4.2 Foundation Materials

Concrete

The following concrete mix designs are appropriate for use with individual upright marker foundations and with multiple marker beam-on-grade type foundations. These concrete mix designs are also suitable for multiple marker beam-on-pier type foundations; however, because of the unique nature of these types of foundations, the design engineer may need to deviate from these mixes to meet the specific design criteria for the beams and piers in question.

Mass produced marker foundations using pre-cast techniques or pre-stressed beam designs may also require some deviation from these mixes to accommodate the different casting procedures followed in this type of manufacture. In such an instance, the pre-cast manufacturing company should use these mixes as a guideline in developing their mix design and the revised concrete mix should match these designs in durability and performance.

Any changes or revisions to the mix design and placement procedures and recommendations

listed below should follow the CSA Standard A23.1, *Concrete Materials and Methods of Concrete Construction*, as a guideline.

Concrete standards for soils that are known to contain sulphates:

- minimum 35 MPa compressive strength;
- maximum water/cement ratio 0.4;
- use Type 20 Moderate Cement if water soluble sulphate (SO₄) in soil measures between 0.1 and 0.2 %, or sulphates in ground water measure between 150 and 1500 mg/litre;
- use Type 50 Sulphate Resistant Cement if water soluble sulphate (SO₄) in soil measures greater than 0.2 %, or sulphates in ground water measure greater than 1500 mg/litre;
- air entrainment 5% to 8%;
- slump 80mm.

Do not use calcium chloride or any admixture containing calcium chloride if the soil is known to contain sulphates.

Concrete standards for all other soils:

- minimum 35 MPa compressive strength;
- maximum water/cement ratio 0.4;
- use Type 10 Normal Cement;
- air entrainment 5% to 8%;
- slump 80mm.

In locations where drainage of the ground water is problematic and the number of freeze thaw cycles is high, using cements that contain Silica Fume can improve the durability of the concrete by reducing its permeability. Silica Fume cement has the designation SF added to the cement type, thus use Type 10 SF, Type 20 SF or Type 50 SF as appropriate for the sulphate conditions noted above.

Water used in mixing all concrete should be clear and free of oils, acids, alkalies, soluble chlorides, organic matter and sediment.

Fine aggregate for the concrete mix should consist of natural sand, manufactured sand or a combination of both. Coarse aggregate should be no larger than 38mm (1 ½") in diameter. All aggregate should be free of organic impurities.

Aggregates should not react with alkalies contained in the concrete. Premature deterioration of the concrete can occur as a result of a reaction between minerals in some rock types and the soluble alkaline components in the concrete. This is typically a regional problem resulting from the use of a particular rock as an aggregate. The source of the aggregate should be contacted to confirm that alkali-aggregate reaction is not a problem and that the aggregate conforms to the CSA Standard A23.1, *Concrete Materials and Methods of Concrete Construction*.

Concrete can be cast on site, or pre-cast off site. When feasible, the use of pre-cast concrete is preferred. Pre-cast concrete typically possesses superior finishing, weathering and strength characteristics over cast-in-place concrete, because of the greater ability to easily maintain

uniform quality control and curing conditions in the controlled environment of a pre-cast facility. In situations where reasonably large quantities of foundations are being cast, pre-cast concrete should not involve a significant cost premium over cast in place concrete, in smaller batches, however, pre-cast concrete could be more expensive than cast in place. Cast-in-place concrete can approach the quality and performance of pre-cast concrete if properly formed, mixed, placed and cured.

When casting concrete it must be placed within properly constructed wooden or metal forms as follows:

- When casting on site, the earthen sides of the excavated foundation pit should not be used as the form to shape the concrete mass.
- Formwork should be adequately fixed in place using wooden stakes and blocking to ensure that straight true lines are formed, and that the formwork does not shift or sag after the concrete has been placed.
- The formwork should be coated with a form release or parting agent that is nonstaining and non-volatile prior to casting the concrete. This will ensure easy removal of the formwork. If no release agent is used prior to casting, the formwork should be dampened with water prior to placing the concrete.
- Before casting the concrete, clean the form of any organic matter, ice or snow prior to placing the concrete.
- Careful stripping of formwork is required, so as not to accidentally chip or mar any surfaces of concrete that is intended to be exposed. Strip the formwork only after the concrete has gained sufficient strength, which usually takes 2 to 3 days.
- When casting concrete on site, wet the granular base prior to placing the concrete. Standing water should not be present.
- Use vibrators to ensure complete consolidation of the concrete and to prevent segregation, honeycombing or voids.
- When casting on site, do not bury or leave the wooden formwork in place after curing, always remove the formwork for re-use or disposal.
- Complete the placement of the concrete within 1-½ hours from the time water was first added to the dry material.
- When placing large amounts of concrete, take precautions to prevent cold joints forming between pours. Cold joints occur when concrete that is placed in the form is allowed to cure somewhat before the next pour of concrete is placed against it. The resulting “cold” joint between the two pours becomes a weak point in the casting.
- When casting on site, do not place concrete when the temperature of the soil or formwork

is below 10°C. Protect freshly cast concrete from freezing for a minimum of 7 days after placement. Use insulated tarps or plastic sheets covered with a thick layer of straw to contain the heat of the curing concrete and to protect the concrete from freezing. Ideally the concrete should not be cast if cold weather, below 5°C to 10°C, is forecast.

- Similarly, protect freshly cast concrete from high temperatures, direct sun, and high winds by covering the concrete with burlap and regularly wetting the burlap. Ensure the burlap is clean so as not to stain the concrete.

The exposed surfaces of concrete should be level and finished with a uniform brush finish.

Steel Reinforcement

Steel reinforcement should conform to CSA Standard A23.1, *Concrete Materials and Methods of Concrete Construction*. Reinforcement bars should be deformed bars. Welded wire fabric may also be used in some instance and should conform to CSA Standard G30.5, *Welded Steel Wire Fabric for Concrete Reinforcement*. Steel strands, tendons and cables may be used in pre-stressed concrete to fabricate multiple marker beam-on-grade and beam-on-pier type foundations, and should conform to CSA Standard G279, *Steel for Prestressed Concrete Tendons*.

The following are general recommendations for reinforcement:

- Reinforcement steel should be clean and free of mud, oil, and heavy rust deposits. Mild mill scale and surface corrosion on the reinforcing is acceptable.
- Reinforcement bars should be supported inside the formwork as required on pre-cast concrete block supports. The concrete blocks should be made of a concrete that is at least equal in quality to the concrete being placed for the footing. Do not use formed wire supports, broken bricks, or pieces of wood as supports for the reinforcement.
- Secure the reinforcement to the supports using plastic coated wire to prevent accidental slipping during placement of the concrete. Do not use plain un-coated wire.
- Reinforcement bars must always be provided with a minimum of 75mm (3") concrete cover on surfaces exposed to the soil.

Epoxy coated reinforcement bars can be used to increase the corrosion resistance of the steel, however, accidental cuts, scratches and nicks in the epoxy coating resulting from rough handling during delivery and installation can reduce the effectiveness of the coating and must be touched up with a brushed on epoxy. Similarly, the ends of the bars, where they have been cut, must also be field coated. Epoxy coated bars must be shop bent using proper tools and equipment so as not to shatter or crack the epoxy coating: bending the bars to too tight a curvature can damage the coating. Epoxy coated bars should never be field bent. Epoxy coated bars should meet the requirements of ASTM standard D3963, *Specification for Prefabricated Epoxy-Coated Reinforcing Steel Bars*.

A practical reinforcement alternative to steel or epoxy coated steel reinforcement is fibre-reinforced polymer reinforcement, in particular glass fibre reinforced polymer reinforcement

(GFRP). This type of reinforcement does not corrode and is of particular benefit in beams where the 75mm concrete cover required for steel reinforcement is difficult to obtain. Also, based on testing by the University of Manitoba, GFRP is preferred for use as the dowels in the pinned connections used for upright markers, because of its strength, flexibility, and corrosion resistance.

Granite

Granite blocks used as foundation pads for flat and other form markers should be fabricated from Barre Gray Granite. When new blocks are being installed to support existing markers, the granite should match the granite of the existing marker.

The top and bottom sides of the granite blocks should be sawn to permit accurate seating of the block on the granular fill base and the marker on the block. The sides of the block may be sawn or cut in a suitable manner determined by the quarry or the local supplier. If the top of the granite base is intended to be exposed at the grave surface, it should be finished with neatly squared edges and a steeled finish.

Epoxy Adhesive

Epoxy Adhesive is used with the pinned connection method to bond the stainless steel or glass fibre dowels to the concrete foundation and granite marker. The epoxy should come pre-packaged in two-part mixing tubes to ensure proper mixing proportions. The epoxy must be appropriate for use in holes cored with diamond coring equipment, and must have a low sensitivity to use in wet or oversized holes. The epoxy should have a reasonably long working time, also referred to as its gel time, of up to thirty minutes to permit adjustment to the alignment of the markers, and should be fully cured within twelve hours at normal temperatures (10 degree Celsius or above).

The epoxy adhesive should match or exceed the following specifications for performance:

Standard	Type IV, grade III, class A, B, C except gel time as per ASTM C881 <i>Standard Specification for Epoxy-Resin Based Bonding Systems for Concrete</i>
Bond Strength	12.4 MPa at 2 days per ASTM C882-91 <i>Standard Test Method for Bond Strength of Epoxy-Resin Systems Used With Concrete by Slant Shear</i>
Compressive Strength	82.7 MPa as per ASTM D-695-96 <i>Standard Test Methods for Compressive Properties of Rigid Plastics</i>
Tensile Strength	43.5 MPa at 7 days as per ASTM D638-97 <i>Standard Test Method for Tensile Properties of Plastics</i>
Elongation at break	2.0% as per ASTM D-638-97 <i>Standard Test Method for Tensile Properties of Plastics</i>
Absorption	0.06% as per ASTM D-570-95 <i>Standard Test Method for Water Absorption of Plastics</i>

Epoxy mixing, placement, and curing procedure must follow the manufacturers' recommendations; however, the following general recommendations also apply:

- Use correct mixing nozzles and applicators, as recommended by the epoxy manufacturer.
- Clean holes with a brush and air prior to injecting epoxy. Cleaning dust from the holes is essential to the performance of the epoxy and most manufacturers supply air nozzles and hand pumps specifically designed to clean holes out.
- Twist the dowels while inserting them into the epoxy filled hole.
- After making adjustments for alignment, do not disturb the anchor or marker prior to completion of the full cure time.

Glass Fibre Reinforced Polymer (GFRP) Rod

Glass Fibre Reinforced Polymer (GFRP) rods are recommended for use as the dowels connecting the granite marker to the concrete foundation in the pinned connection method. The rods must be glass fibre reinforced polymer bars with a sandy coating on their surface to aid in bond development. GFRP rods must conform with the standards outlined in CAN/CSA-S806-02, *Design and Construction of Building Components with Fibre Reinforced Polymers*. Material specifications for the rods must match the following:

Bar diameter	16mm (5/8")
Binding material	Modified vinyl ester, volume fraction 25%
Fibre reinforcement	Continuous E-glass fibres, volume fraction 75%
Ultimate Tensile Strength, F_u	674 MPa
Tensile Modulus of Elasticity, E_t	42000 MPa

Follow the manufacturer's recommendations for handling, storing, cutting and placing GFRP rods.

Stainless Steel Threaded Rod

Stainless Steel threaded rods are acceptable for use as the dowels connecting the granite marker to the concrete foundation in the pinned connection method, though GFRP rods are preferred. The rods must be AISI 316 stainless steel rods, threaded to aid in bond development. Material specifications for the rods must match the following:

Bar diameter 16mm (5/8")

Follow the manufacturers recommendations for handling, storing, cutting and placing stainless steel rods.

Cementitious Grout

Cementitious grout is used with the grouted in pocket and grouted between bumper connection methods to bond the granite marker in the pocket or between the bumpers. The grout should be a pre-blended cementitious mixture requiring the addition of only water to ensure ease of mixing on site. The grout must be concrete coloured, non-shrinking, non-metallic, non-corrosive and must not contain chlorides. The grout should also only develop low levels of heat when curing.

The grout should match or exceed the following specifications for performance:

Compressive Strength	35 MPa at 28 days as per CSA A23.2-1B <i>Methods of Test for Concrete</i>
Flow Cone	25-30 sec as per CSA A23.2-1B <i>Methods of Test for Concrete</i>
Aggregate Grading	100% passing 2.5mm as per ASTM C136 <i>Standard Test Method for Sieve Analysis of Fine and Coarse Aggregates</i>
Durability Factor	101 as per ASTM C666 (Procedure A) <i>Standard Test Method for Resistance of Concrete to Rapid Freezing and Thawing</i>

In installations where water soluble sulphates (SO₄) in the soil measure greater than 0.2 %, or sulphates in ground water measure greater than 1500 mg/litre; ensure that the grout is also sulphate resistant.

Grout mixing, placement, and curing procedures must follow the manufacturers recommendations, however, the following general recommendations also apply:

- Remove all grease, oil, ice, snow, or other foreign deposits from the surfaces into which the grout will come into contact.
- Roughen the concrete surfaces to which the grout will bond, remove all dust and loose particles using a brush or oil-free compressed air.
- Keep the concrete surfaces with which the grout will come into contact wet for a several hours before grouting. Surfaces must be saturated surface dry (surface will not absorb any more moisture) at the time of grouting. Remove any standing water before grouting.
- Apply a slurry of grout to the concrete surfaces with which it is intended to bond (i.e. inside faces of pocket and bumpers). A slurry is a very liquid mixture of the grout, made by adding additional water to the grout mixture.
- Grout should be used within one hour of mixing, discard any grout which has not been used within this time in an appropriate manner.
- Moist cure the grout, starting immediately after placement and finishing, in accordance with manufacturers instructions. Typical curing methods include misted water, damp burlap, and white polyethylene film. Protect freshly placed grout from direct sunlight, wind, rain and frost.
- Protect grout from freezing for a minimum of 72 hours after placement.

Granular Fill

Granular fill used for drainage purposes beside and below the foundation pads and beams should be a granular material composed of inert, hard, durable crushed stone or gravel. The fill should be screened of fine particles and free of organic material, and clay and silt balls.

Two gradations of granular fill are required depending on the depth of the fill: base course and sub-base course. The base course and sub-base course material should fall within the gradations outlined in Table 4.4a, below and determined in accordance with ASTM C136 *Method for Sieve Analysis of Fine and Coarse Aggregates*.

Table 4.4a	Recommended Gradation of Base Course and Sub-base Course Granular Fill																									
	Passing Standard Sieve	Gradation Limits (Percent passing by weight)																								
		<table border="1"> <thead> <tr> <th>Base course granular</th> <th>Sub-base granular</th> </tr> </thead> <tbody> <tr> <td></td> <td>100</td> </tr> <tr> <td>100</td> <td>50-85</td> </tr> <tr> <td>80-100</td> <td></td> </tr> <tr> <td>50-100</td> <td></td> </tr> <tr> <td>40-70</td> <td></td> </tr> <tr> <td>25-50</td> <td></td> </tr> <tr> <td>15-35</td> <td></td> </tr> <tr> <td>5-20</td> <td></td> </tr> <tr> <td></td> <td>0-16</td> </tr> <tr> <td>0-5</td> <td></td> </tr> <tr> <td></td> <td>0-5</td> </tr> </tbody> </table>	Base course granular	Sub-base granular		100	100	50-85	80-100		50-100		40-70		25-50		15-35		5-20			0-16	0-5			0-5
Base course granular	Sub-base granular																									
	100																									
100	50-85																									
80-100																										
50-100																										
40-70																										
25-50																										
15-35																										
5-20																										
	0-16																									
0-5																										
	0-5																									
75 mm		100																								
25 mm	100	50-85																								
19 mm	80-100																									
9.5 mm	50-100																									
4.75 mm	40-70																									
2.36 mm	25-50																									
1.18 mm	15-35																									
0.3 mm	5-20																									
0.15 mm		0-16																								
425 µm	0-5																									
75 µm		0-5																								

The thickness of the layers of granular material placed beneath the foundation will vary depending on the soil type present. Table 4.4b, below details the thickness of the fill and compaction recommendation for each common soil type.

The granular material should be placed in maximum 150mm (6”) deep layers, and each layer should be compacted prior to the placement of subsequent layers. Layers compacted with vibrating plate compactors, or similar, should be compacted to 95% standard proctor density.

Table 4.4b Recommended Thickness Of New Granular Fill By Soil Type		
Soil Type	Recommended Thickness of New Granular Fill	
	Single Marker Foundations	Multiple Marker Beam-on-Grade Foundations
Reasonably free draining coarse granular soil (i.e. gravely soil), including glacial till.	No new granular fill is required beyond that necessary for leveling purposes.	Minimum 100mm (4") base course compacted by vibrating plate or similar, for leveling purposes.
Reasonably free draining sandy soil with no ongoing soil movement problems.	Minimum 150mm (6") base course compacted by hand.	Minimum 200mm (8") base course compacted by vibrating plate or similar.
Organic soils (including peat and organic silts), clays, and fills with ongoing soil movement problems.	Minimum 250mm (10") compacted by vibrating plate or similar. Base course 4" thick, sub-base course 8" thick.	Minimum 400mm (16") compacted by vibrating plate or similar. Base course 4" thick, sub-base course 12" thick.

Geotextile Filter Fabric

The granular fill should always be wrapped with a geotextile filter fabric to prevent it from becoming clogged with fine soil particles transported by water movements. The geotextile should be a non-woven synthetic fabric with a filtering opening size (FOS) of 75 to 150 micrometers. Any joints in the fabric should be overlapped by a minimum of 200mm (8").

4.4.3 Marker / Foundation Connections

Three methods of connecting grave markers to their foundations are presented in this section: pinned, grouted in pocket, and grouted between bumpers. The following presents details on the fabrication and installation procedures recommended for each connection method. A brief discussion is also presented on connections between flat and special order markers, and their foundations.

Pinned Connection for Upright and Special Order Markers

The pinned connection method is the preferred method for all upright marker to foundation connections. The pinned connection method uses two GFRP or stainless steel dowels to connect the granite marker to the concrete foundation. Epoxy adhesive bonds the dowels to the marker and the foundation. Holes, into which the dowels are epoxied, must be drilled into the base of the granite marker and top of the concrete foundation.

Some special order markers, notably the taller wedge markers, also require the marker to be fixed to the foundation base, and the pinned connection type should again be used in these situations. Another less common special order marker is one that involves the use of upright markers that are connected to exposed granite bases, which in turn sit on multiple marker beam type foundations. This emplacement method is used in some cemeteries when the marker is located in civilian areas, and cemetery regulations forbid attaching the markers to the

foundations. These markers should use the pinned connection to connect the marker to its granite base.

Figure 4.4h, below, illustrates the pinned connection detail for connecting an upright marker to its concrete foundation and the recommended installation process. The details and procedures are similar when using this connection detail for other markers types.

The following steps are required to complete the installation of a marker using the pinned connection method. Steps 2 and 3 can typically be completed at the memorial contractors workshop, as well as steps 4 and 5 for single marker foundations. The other steps are completed on site at the cemetery:

1. Cast and install the foundation pad or beam following the recommendations for new installations. Ensure that none of the steel reinforcement in the foundation passes through the middle of the foundation where the holes for the dowels will be core-drilled.
2. Using a template to ensure accuracy, core-drill holes in the bottom of the granite marker. Ensure the holes are straight into the marker and do not tilt towards one face of the marker. Use a diamond-coring bit sized slightly larger than the diameter of the dowel, and note that the sand coating on the GFRP dowels increases their actual diameter closer to 17.5 mm (11/16"). Core drill the holes 150 mm (6") deep, do not over-drill the depth. Clean the holes of all dust or excess water using oil free compressed air.
3. Inject epoxy into the holes and insert the dowel, twisting it as it is being pushed into the hole. Inject only enough epoxy to fill the hole when the dowel is completely inserted (the actual quantity will vary depending on the depth of the hole and will become more apparent after a few installations). Partially withdraw the dowel to check that full coverage with the epoxy has been achieved. Clean off any epoxy that oozes from the hole taking care to keep it off of the faces of the marker. Allow the epoxy to fully cure before moving the marker.
4. Using a template to ensure accuracy, core-drill holes into the foundation pad or beam. Ensure the holes are plumb by using a bubble level or similar to check the angle of the drill while drilling. Use a 25mm (1") diameter diamond core drill. Drill the holes 150mm (6") deep, over-drill the depth of the hole slightly if necessary to ensure that the dowel does not bottom out when the marker is set on the foundation (measure the depth of the hole and compare with length of exposed dowel protruding from the marker). Clean the holes of all dust or excess water using oil free compressed air.
5. Fill holes in foundation one half to two thirds full of epoxy (the actual quantity will vary depending on the depth of the hole and will become more apparent after a few installations). Carefully and slowly lower the marker onto the foundation. After the marker is fully seated on the foundation, temporarily lift the marker several inches and check to see that the epoxy in the holes has filled the hole to the top. Add more epoxy as required to fill the hole when the marker is fully seated, and re-lower the marker.

6. Check marker alignment and use small wood shims to level and align the marker. Complete all adjustments within the gel time of the epoxy. Clean any epoxy that may have oozed out from beneath the marker if this is an exposed foundation emplacement. Use lacquer thinner to clean the epoxy.
7. Allow the epoxy to fully cure before removing shims and backfilling topsoil around marker.

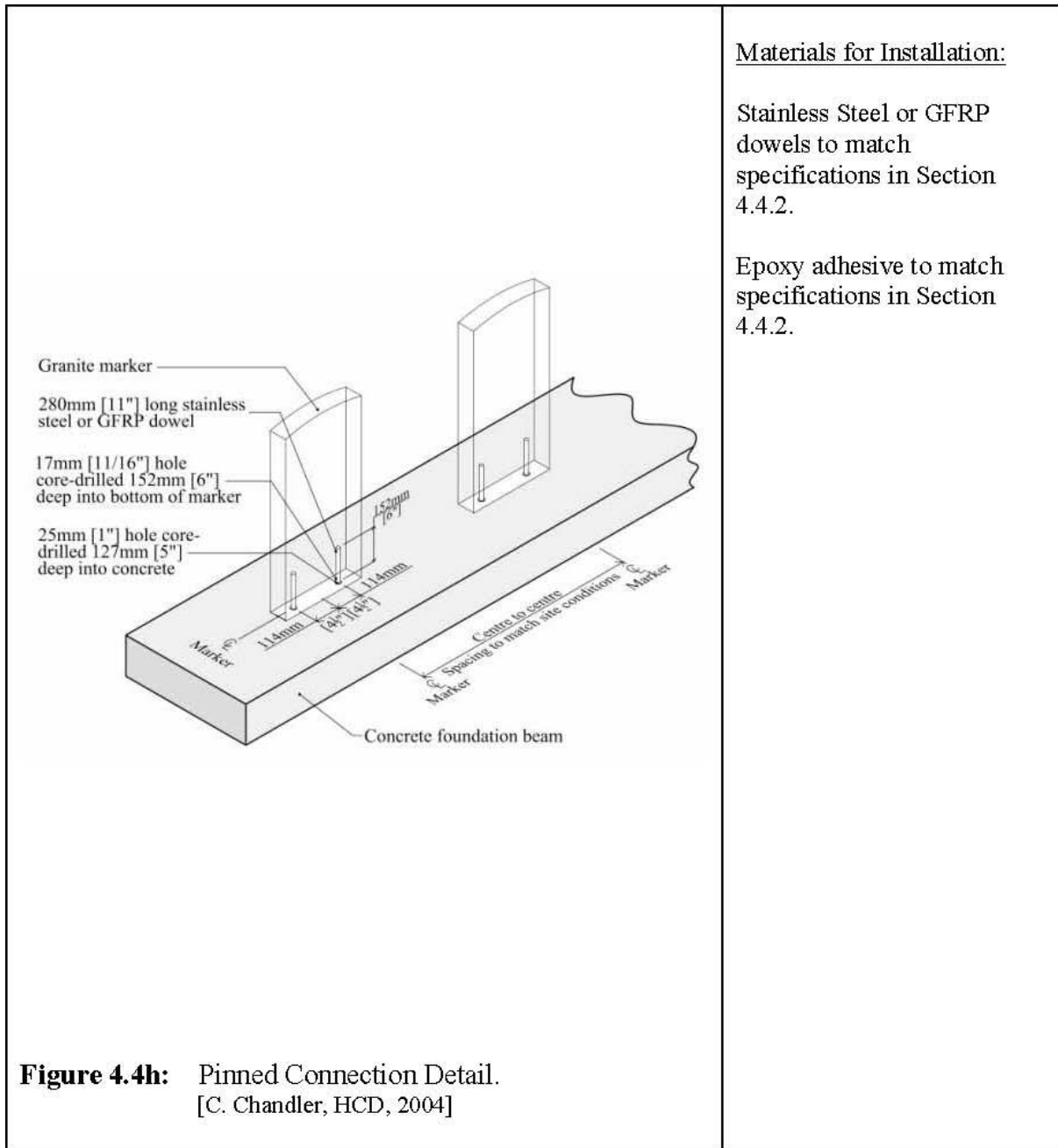

Grouted-in-Pocket Connection for Upright Markers

The grouted-in-pocket connection type is acceptable for use with upright markers when installing a new marker on an existing foundation beam with pre-existing pockets cast for this type of connection. New installations on new foundations should utilize the pinned connection method, which allows for a uniform depth of soil over top of the beam.

The grouted-in-pocket connection involves setting the marker in a roughly 100 mm (4") wide x 400 mm (16") long pocket previously cast into the middle of a multiple marker foundation beam. The actual dimensions of the pocket may vary, and in some cases, a trough is cast along the entire length of the beam, instead of individual pockets.

Figure 4.4i, below, illustrates the pocket connection installation process for fastening a marker using this type of connection.

The following steps are required to complete the installation of a marker using the grouted-in-pocket connection. All of the following steps will be completed at the cemetery:

1. If necessary, excavate and expose the existing beam foundation and pocket. Clean the pocket of all soil and debris. If the pocket has been temporarily grouted full, remove the grout using small pneumatic or electric chipping hammers. Place and align the new marker in the pocket. Fill the bottom of the pocket with crushed stone to a depth required to suit the height of the marker.
2. Use wooden wedges to adjust the alignment of the marker to match the markers previously installed on the same foundation beam, four wedges should be sufficient. The wooden wedges should be soaked in water prior to use.
3. Prior to placing the grout, wet the inside of the pocket and the faces of the granite marker with a misting of water over a period of several hours or until the surfaces stay damp. Grout the marker into place using the grout mix and placement procedures recommended by the grout manufacturer and above. Take care not to smear or spill the grout on the face of the marker or on the foundation around the pocket. Clean any spills or smears immediately using water and a soft bristle brush.
4. Ensure that the grout joint is proud of the concrete and is sloped from the marker down to the concrete as shown in Figure 4.4j. The grout joint should have a smooth finish matching that of the concrete.
5. Cure the grout following the grout manufacturers recommended procedures. Once the grout has set to a sufficient strength to support the marker, remove the wooden wedges, and fill the remaining joint openings with additional grout. Cure the grout following the grout manufacturers' recommended procedures.
6. If the existing beam is buried, ensure the grout is fully cured before backfilling topsoil around marker.

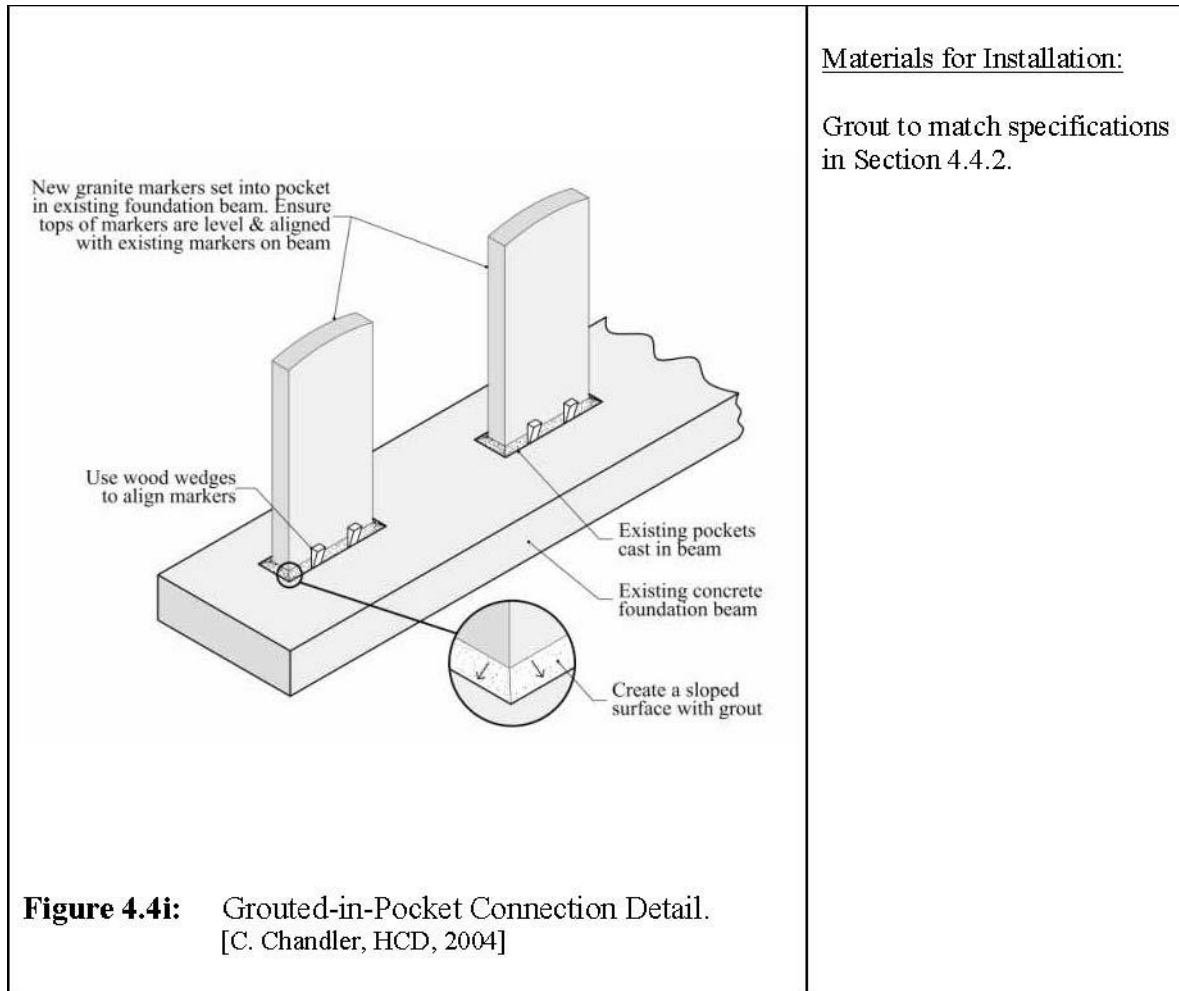

Grouted-Between-Bumpers Connection for Upright Markers

The grouted-between-bumpers connection type is acceptable for use with upright markers when installing a new marker on an existing buried foundation installation with pre-existing bumpers. New installations on new foundations should utilize the pinned connection method.

The grouted-between-bumpers connection involves setting the marker between concrete “bumpers” that have been cast on the top side of the multiple marker foundation beam, and grouting the marker in between these bumpers.

Figure 4.4j, below, illustrates the installation process for fastening a marker using this type of connection.

The following steps are recommended to complete the installation of a marker using the grouted-between-bumpers connection. All of the following steps are completed at the cemetery:

1. Excavate and expose the existing beam foundation and bumper. Clean the area between the bumpers of all soil and debris. Erect and align the marker in between the bumpers. Use wood shims at the base of the marker to align its height with adjacent

markers

2. Use wooden wedges to adjust the alignment of the marker to match the markers previously installed on the same foundation beam, four wedges should be sufficient. The wood wedges should be soaked in water prior to use.
3. Prior to placing the grout, wet the bumpers and the faces of the granite marker with a misting of water over a period of several hours or until the surfaces stay damp. Grout the marker into place using the grout mix and placement procedures recommended by the grout manufacturer, and above.
4. Take care not to smear or spill the grout on the face of the marker where it will be visible after burial of the foundation. Clean any spills or smears immediately using water and a soft bristle brush.
5. Ensure that the grout joint is proud of the concrete and is sloped from the marker down to the concrete as shown in Figure 4.4h.
6. Cure the grout following the grout manufacturers recommended procedures. Once the grout has set to a sufficient strength to support the marker, remove the wooden wedges and fill the remaining joint openings with additional grout. Again cure the grout following the grout manufacturers' recommended procedures.
7. Ensure the grout is fully cured before backfilling topsoil around marker.

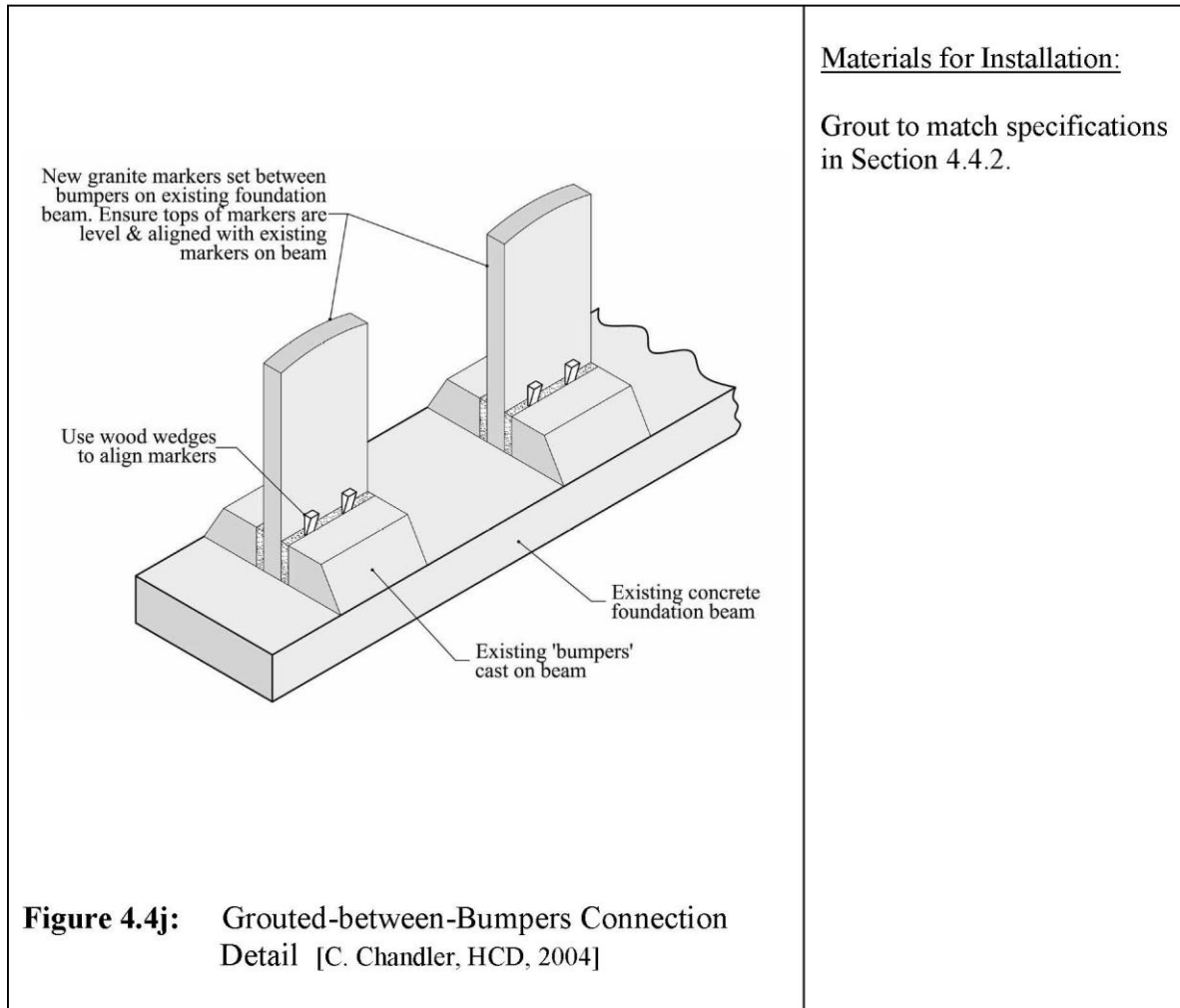

Connections for Flat, Bronze, Pillow and Scroll Markers

Flat, bronze, pillow, and scroll type markers should not be mechanically anchored to their foundations in any way. Fixing these markers will subject them to a greater risk of damage in the event of an accidental impact with a lawn mower or other maintenance equipment. Where vandalism is a concern, however, some light attachment may be appropriate. In the case of buried emplacements, a bed of mortar placed between the marker and its foundation will help hold the marker in place. In the case of exposed foundation emplacements, the markers can be adhered to the foundation with dabs of silicone sealant. It is very important to only use dabs of sealant and not continuous beads or lines, so as not to inadvertently trap moisture between the marker and its foundation.

Note that in the case of bronze markers, the connection in question is between the granite base on which the bronze plaque is mounted and the granite or concrete foundation on which this base rests. The bronze plaque must be appropriately fixed to its granite base as detailed in Section 4.1.4.

4.5 Grave Surfaces

While mown grass is the most common surface material for veterans' gravesites in Canada, it is not a practical material for installation in all parts of the country. Cemeteries subjected to extreme cold, on-going drought, or substantial salt accumulation due to ocean spray may not be able to keep grass alive over several years with a reasonable amount of maintenance effort. Therefore, this section will provide standards for surfacing veterans' gravesites with non-living material, as well as with turfgrass. It will also discuss the conditions that need to be in place before other plant material can be considered for installation, and why the use of other plant material is not recommended at this time.

4.5.1 Non-Living Surface Materials

This recommended standard for gravesites surfaced with local gravel is derived from existing practices in Churchill, Manitoba and parts of Newfoundland and Labrador where grass is not easily grown.

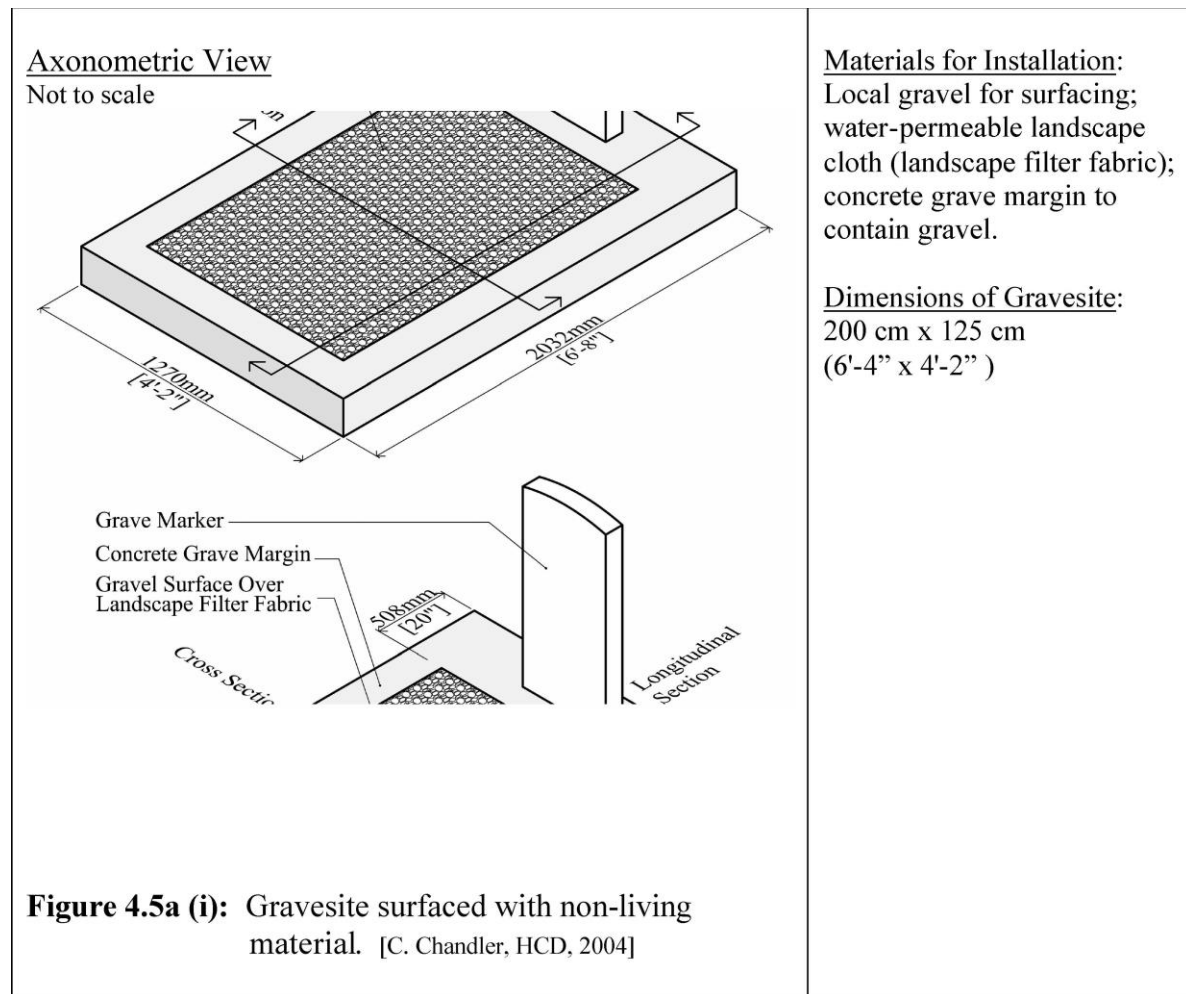

Cross-Section Through Grave

Not to scale

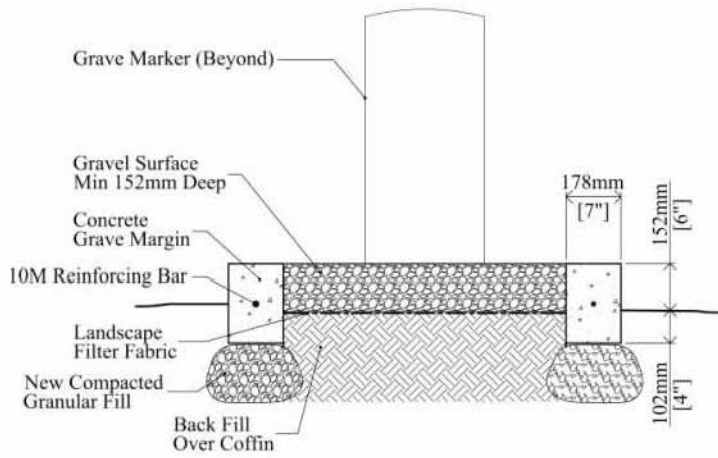

Figure 4.5a (ii): Cross-section detail of gravesite surfaced with non-living material. [C. Chandler, HCD, 2004]

Materials for Installation:
New granular fill beneath concrete curb. For depth of fill and compaction requirements refer to **Section 4.4.2**. Treat curb as a single marker foundation.

New concrete curb. Refer to **Section 4.4.2** for recommended concrete mix design and forming and curing requirements.

New reinforcing. Refer to **Section 4.4.2** for reinforcing specifications and placement requirements.

Longitudinal-Section Through Grave

Not to scale

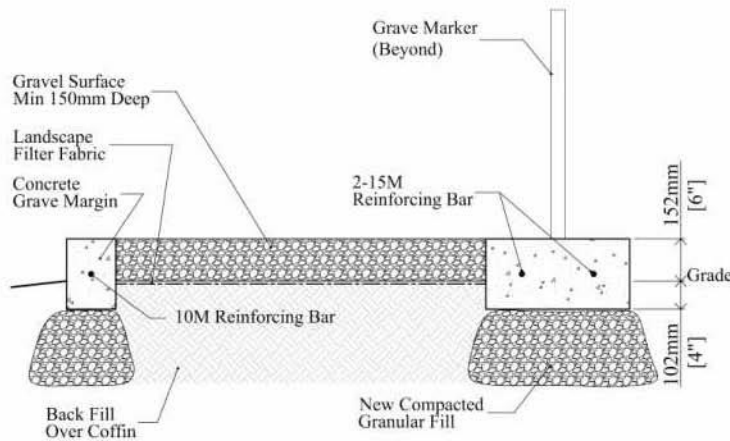
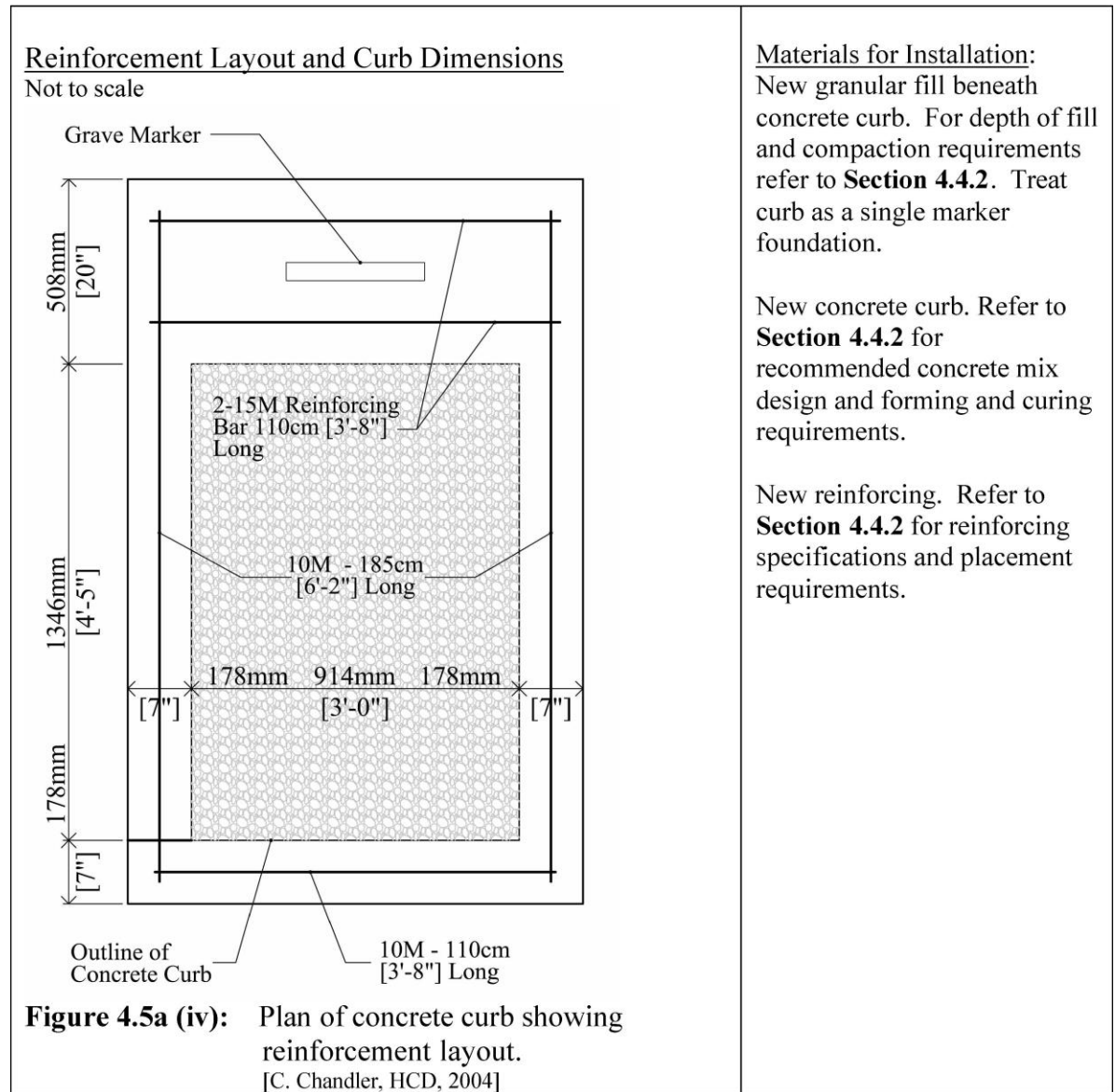

Figure 4.5a (iii): Longitudinal-section detail of gravesite surfaced with non-living material. [C. Chandler, HCD, 2004]

Materials for Installation:
New granular fill beneath concrete curb. For depth of fill and compaction requirements refer to **Section 4.4.2**. Treat curb as a single marker foundation.

New concrete curb. Refer to **Section 4.4.2** for recommended concrete mix design and forming and curing requirements.

New reinforcing. Refer to **Section 4.4.2** for reinforcing specifications and placement requirements.



4.5.2 Turfgrass

Mown turfgrass is the most common grave surfacing material in Canada. While turfgrass in most cemeteries with veterans' gravesites is already well established, a number of grass mixtures can be recommended for areas that need renovation. These mixtures are applicable to either seed or sod.

The recommendations for grass mixtures use the Plant Hardiness Zones developed by Natural Resources Canada and Agriculture and Agri-Food Canada using average climatic data (such as minimum winter temperature, length of frost-free period, summer rainfall, maximum temperature, snow cover, and elevation) to predict plant survival. Plant Hardiness Zones are numbered with the letters 'a' or 'b' attached to the number. The zones range in Canada from 0a, the coldest zone, to 8a, the warmest zone. A zone with 'a' appended to its number is colder than the zone of the same number with 'b' appended. To give some sense of the Plant Hardiness Zones, Vancouver is located in zone 7a, Winnipeg in 2b, Toronto in 5b, Quebec City in 4b, and

St. John’s in 5a.

Maps of the Plant Hardiness Zones in Canada are available from Natural Resources Canada or Agriculture and Agri-Food Canada. All gravesite inspectors should know the Plant Hardiness Zones for the cemeteries they cover.

Table 4.5a		
Plant Hardiness Zone	Other Conditions	Grass Mix
Zones 1a to 2a	Sunny	50% Kentucky bluegrass (<i>Poa pratensis</i>) 40% creeping red fescue (<i>Festuca rubra rubra</i>) 10% annual ryegrass (<i>Lolium multiflorum</i>) Note: Annual ryegrass serves as a nurse crop for the first year until other grasses are established.
Zones 2b to 5b	Sunny	60% Kentucky bluegrass (<i>Poa pratensis</i>) 30% creeping red fescue (<i>Festuca rubra rubra</i>) 10% perennial ryegrass (<i>Lolium perenne</i>)
Zones 2b to 5b	Shade	70% creeping red fescue (<i>Festuca rubra rubra</i>) 20% Kentucky bluegrass (<i>Poa pratensis</i>) 10% perennial ryegrass (<i>Lolium perenne</i>)
Zones 6a to 8a	Sunny	60% perennial ryegrass (<i>Lolium perenne</i>) 30% creeping red fescue (<i>Festuca rubra rubra</i>) 10% Kentucky bluegrass (<i>Poa pratensis</i>)
Zones 6a to 8a	Shade	70% chewing fescue (<i>Festuca rubra commutata</i>) 30% perennial ryegrass (<i>Lolium perenne</i>)

To determine the need for nutrients and pH amendments to grow healthy turfgrass, the soil should be tested once every five years. Results of the soil test will determine the type and amounts of fertilizer to increase soil fertility, as well as any need to add lime or sulphur to bring the soil pH into the range that supports the growth of turfgrass.

4.5.3 Other Plant Material

CWGC cemeteries in northern Europe and other parts of the world have mixed plantings of perennials, alpins and floribunda roses immediately adjacent to the grave markers. The initial concept for this grave surface treatment, developed toward the end of the First World War, was to make an association between the gardens of Great Britain and the foreign fields in which the soldiers are now buried.

At the beginning of this project, VAC managers familiar with the CWGC cemeteries in Europe, asked the HCD team to provide list of plants suitable for veterans' gravesites within Canada. After reviewing the situation in Canada and the CWGC maintenance regime in Europe, HCD has come to the conclusion that gravesite surface treatments involving plant material other than turfgrass should not be recommended for veterans' graves managed by VAC.

The reasons for this recommendation are as follows:

1. To provide planting beds at only some gravesites, and not others, would contradict the principle that all veterans are to be treated with equal dignity in death. Therefore the scale of such a project would be immense.
2. The degree of horticultural expertise required to maintain mixed borders in good order exceeds the capacity of most cemetery maintenance personnel in this country.
3. Contracting to the private sector for the care of planting beds at all veterans' gravesites would be extremely expensive given the numbers of burials. Furthermore, the landscape maintenance industry in Canada is also not geared to the care of mixed borders.
4. If VAC were to take on the task of caring for planting beds at veterans' gravesites by starting a landscape maintenance program in Canada similar to that run by the CWGC in Europe, it would require a minimum of two thousand horticultural workers with equipment and transportation supplied by Canadian taxpayers.
5. Most of Canada is subjected to drought through July and August. This would mean that planting beds would require regular watering during those two months. This watering will increase the build-up of biotic growth on the grave markers, and will increase the need for cleaning in order to ensure that inscriptions remain legible.
6. In order to be visible within the mixed planting beds, all existing flat granite markers would have to be raised and placed on foundations so that they would no longer be flush with the ground surface.

Appendix B
National Technical Maintenance Manual – Section 5.0

5.0 THE CYCLE OF GENERAL MAINTENANCE FOR EXISTING GRAVESITES

5.0.1 Orientation for Gravesite Inspectors

This section presents a series of national standards for the maintenance of gravesite elements that will assist in ensuring that Veterans' graves across the country, for which VAC are responsible, are treated with the respect that they deserve. The section is entitled 'the cycle of general maintenance' because it is important to remember that successful maintenance of exterior resources is an ever-recurring system involving regular inspections, repetitive maintenance at appropriate intervals, and special measures as indicated by the results of inspections. After presenting the general maintenance activities appropriate to each gravesite resource, this section then proposes inspection schedules for VAC.

5.1 Marker Cleaning

Cleaning to remove staining or discoloration should only be performed when the staining or discoloration inhibits the legibility of the inscriptions. The recommended test for legibility is borrowed from the CWGC standards: inscriptions on grave markers are deemed to be legible if they can be read at a glance under normal light conditions from a distance of two metres (6½ feet).

Attempts at cleaning should always be carried out starting with the gentlest means possible and advancing to the next harshest method only if required. Cleaning methods should also always be first tested on a sample of the stain to determine their effectiveness and to identify whether they cause any unanticipated damage to the marker, its foundation, or the surrounding plantings.

Multiple stains can occur on a single marker or foundation. In such instances the cleaning approaches should again always begin with the gentlest method, and as the cleaning proceeds to the harsher methods for the more stubborn stains, the treated areas should be limited only to the remaining stained parts of the marker.

5.1.1 Simple Cleaning

The following are general guidelines that should be followed in any attempts at cleaning stains on granite or bronze markers:

- Wash and scrub markers and their foundations with clean water and a nylon brush.
- Do not undertake cleaning with water when freezing temperatures are expected. Ensure that there is sufficient time for the stone to dry before freezing will occur.
- Use clean water only. Test the water to determine if it contains impurities or minerals that

could produce staining such as salts and iron. If necessary, filter the water or use a chelating or complexing agent such as ethylene diamine tetra-acetic acid (EDTA) to make metallic ions inactive. Specialist technical advice should be sought to help in interpreting the results of any testing, to determine the most effective filtering method, and/or to determine the most effective additive to use to address any water quality issues.

- Do not add detergents to the water.
- Soaking stains and adhered materials with water for a short time prior to cleaning can often help to soften and loosen the materials to improve the effectiveness of the cleaning.
- Do not use steel brushes or metal tools such as spatulas, knives, or screwdrivers.
- Do not use household cleaners with abrasives such as Vim, Spic and Span, Fantastic etc.
- Do not use household cleaners such as Clorox, Borax, Comet or any cleaners with sodium hydroxide (NaOH).
- Do not use abrasive pads such as Brillo, steel wool or ScotchBrite.
- Do not use biocides to kill off plants, such as lichen.
- Do not use rotary grinders or sanders.
- Do not use abrasive “sandblasting” techniques on granite or bronze markers.
- Do not use acids as additives to the water when cleaning bronze markers.

In general, acidic cleaners are not recommended because of the potential for damage to the marker material, the environmental impact on nearby plants and soil, and the health concerns associated with their application and use.

Clean/Control	Surface	Method
Algae	Stable sandstone surfaces that have algae	Wash with water(no pressure); brush with a soft natural bristle brush; rinse with water
Lichen	Stable sandstone surfaces that have Lichen	Do not attempt to clean or control crustose lichen, particularly ‘map lichen’. Foliose or leaf-like lichen may be controlled by gently removal by rubber scraper or soft brush.
Moss	Stable sandstone surfaces that have moss	Gentle removal by rubber scraper or by hand followed by water wash (no pressure).
Loose soil organic debris	Stable sandstone surfaces that have	Wash with water (no pressure); brush with a natural bristle brush if necessary; and rinse with water. If surface and

	soil and debris, particularly near the marker base.	material is dry, brush off debris with a dry natural bristle brush.
All growth, soil and debris	Loose, unstable sandstone surfaces and markers that have bedding plane fractures	Do not clean near surfaces that are unstable or spalling. Avoid washing if water seeps into fractures. Dry brush with natural bristles for areas with bedding plane fractures
Soil and organic debris	Concrete bases	Wash or brush off with a broom. (Raising the base to prevent collection of debris is recommended.)

5.1.2 Pressure Washing

If washing with a nylon brush and water does not produce an acceptable degree of removal, use pressure-washing techniques. Pressure washing is acceptable, provided:

- the maximum pressure is below 400 psi,
- a fan type tip with a minimum 15° spread is used, and
- the nozzle is held perpendicular to the surface at a distance between 18" and 30" from the surface.

Use extreme care with pressure washing so as not to damage or degrade the softer materials of mortar joints between the marker and concrete foundation and the concrete foundation itself. Care must also be exercised when pressure washing the inscriptions as the pressure of the water can break off fragile parts of the inscription.

Pressure washing is not acceptable for use on flat markers with lead filled inscriptions as the water pressure can lift and blow off the lead filling. This is particularly pertinent if any of the lead lettering is already missing.

Do not use acids or other additives when pressure washing. To minimize potential damage, pressure washing should only be used to loosen and soften any adhered organic material. Once this material becomes loose, it should be scrubbed off using a nylon brush and water.

5.1.3 Sources of Staining

The stains occurring on Veterans’ grave markers can be from several sources. Although the general principles of cleaning outlined above still apply, some additional steps may also be necessary depending of the source on the stain.

Lichen

- Prior to washing, remove any loose lichen using a spatula made of wood, plastic, or rubber. Do not use metal spatulas.

- Lichens will return. The schedule for cleaning lichens should be determined based on the rate of growth of the lichens and their impact on the legibility and presentation of the markers. Lichens that have been present on the marker for long periods of time can produce very stubborn stains that cannot be satisfactorily cleaned using the simple methods described above. If the inscription is still illegible after cleaning using simple methods, contact VAC to determine if the stone should be replaced.
- Stains from tree sap, backsplash, and standing water
- Organic stains, which have been present on the marker for long periods of time, can become very stubborn and will resist the simple cleaning methods described above. If the inscription is still illegible after cleaning using simple methods, contact VAC to determine if the stone should be replaced.

Efflorescence

- Efflorescence is caused by moisture that contains salts moving through the stone and evaporating on the face of the stone, leaving salt deposits on the face. Improving drainage around the marker, to reduce moisture absorption, will reduce the severity of the efflorescence. Efflorescence could also indicate problems with the soil or the local water supply. Sub-efflorescence may be occurring where efflorescence is observed. Sub-efflorescence is salts that are deposited just beneath the surface of the stone and can produce expansive forces that can lead to blistering, shaling and deterioration of the surface.
- Brush and water and pressure washing techniques will remove the efflorescence powder off of the marker, however, the cause of the efflorescence, soluble salts, will remain in the stone and the efflorescence will usually return unless steps are taken to address the source of the moisture.
- For severe efflorescence, poultices may be necessary. Poultices are stiff paste-like mixtures that are applied directly over the affected area of the stone. Poultice materials such as Fullers earth, kaolinite, or diatomaceous earth are used to create the thick paste to which salts are drawn to during evaporation. Shredded paper or paper towels can also be used as the inert poultice material. The following is the basic process to follow with poultices:
 - Wet the affected area of the marker with water and apply the poultice mixture in a layer that is about 12 mm (1/2") thick and allow it to dry naturally.
 - Once dry (the poultice mass will have cracked and cupped up), carefully remove the poultice material. Ensure that the poultice material does not fall onto and get mixed into the soil as this can return the soluble salts to the soil where they can be transported back into the stone.
 - Wash the treated area with clean water and a nylon brush.

Rust staining

- Washing with a brush and water or with a pressure washer will typically not remove moderate or heavy rust stains. Cleaning rust stains usually requires the use of harsh chemicals and is generally beyond the scope of simple cleaning or regular maintenance. If the inscription is still illegible after cleaning using simple methods, contact VAC to determine if the stone should be replaced.
- A water supply that is contaminated with metallic ions can lead to rust staining that appears as a uniform discoloration of the entire marker. This type of staining rarely will result in an inability to read an inscription and should not require cleaning. Weathering and rainfall may eventually rinse this type of staining off. To reduce the tendency for this type of staining to occur, treat the water supply through filtering or the use of chelating or complexing agents, to remove the metallic ions.

Tire-tread marks

- Pressure washing should typically remove tire-tread marks. If the inscription is still illegible after pressure washing, contact VAC to determine if the stone should be replaced.

Paint and graffiti

- Contact VAC to report incidents of graffiti and for recommendations on cleaning.

Other stains

- Other specific stains encountered, and not mentioned above, may require more than the simple cleaning methods. If the inscription is still illegible after cleaning using simple methods, contact VAC who will determine if the stone should be replaced or if more intensive environmentally challenging procedures are warranted.

5.2 Marker Realignment

Marker realignment should be carried out as part of the regular maintenance regime. One of the major causes of damage to flat markers is accidental impact from lawnmower blades hitting markers that have heaved or moved upwards. The alignment of the markers is also an important facet of the presentation of the grave.

Flat markers should be regularly realigned to ensure that their top surface is level and flush with the soil surface. By levelling a percentage of the flat markers at the cemetery each year as part of the maintenance program, the entire holdings of the cemetery can be effectively managed over a several year cycle. The number of markers included in each year's maintenance program would depend on the total number of markers at the cemetery. Whenever a flat marker is re-levelled, it is important to assess the condition of its foundation: flat markers that are founded directly on the soil should be reinstalled on proper foundations as described in **Section 4.0**, Standards for the Installation of New Gravesites.

Upright markers should be realigned whenever the misalignment makes it difficult to read the inscriptions on the marker, or when the misalignment detracts significantly from the presentation

of the grave.

It is important to determine the cause of the misalignment. Most causes of marker misalignment can be determined by using the Problem Identification Sheets included in **Section 6.0**. These also include recommended corrective actions that fall within the scope of a general cycle of maintenance.

If misalignment of markers is a widespread problem throughout the site, it is recommended that a specialist engineering consultant be engaged to investigate and confirm the cause of the misalignment. This is particularly the case when the misaligned markers all utilize the same type of foundation design.

If a cluster of markers that are presently supported by individual foundations regularly fall out of alignment, consider introducing a new multiple marker beam-type foundation. In this instance it is recommended that a specialist engineering consultant be engaged to investigate the cause of the misalignment and the suitability of the multiple marker beam-type foundation design.

5.3 Marker Mounting

Regular maintenance of marker mounting connections is important to prevent premature failure of these connections. Of the five common connection types used, the grouted-in-pocket and grouted-in-slot are likely to most often require maintenance. Exposed grout used in these types of connections is particularly susceptible to moisture saturation and freeze-thaw damage. The grout should be inspected for signs of cracking or deterioration, and replaced as required.

Methods of inspecting the connections include the following:

- Lightly move the marker back and forth by hand to see if there is any evidence of looseness. Does the marker move back and forth easily? A loose marker indicates a possible failed connection; if the foundation for the marker is buried, some excavation should be carried out to expose the connection between the marker and the foundation.
- Check the grout for obvious signs of cracking or delamination (flaking of the surface of the grout). Cracks will allow moisture to enter into the pocket or slot which can lead to premature failure of the connection as a result of freeze thaw damage. Delaminated grout is also an indication of freeze thaw damage, and can also lead to premature failure of the grout.
- For grouted-in-pocket connections, lightly drag the tip of a screwdriver or head of a hammer over the length of the grout joint. A hollow “popping” sound will indicate that the grout has de-bonded from the marker or foundation and should be replaced.
- For grouted-in-slot and grouted bumper connections, lightly tap the surface of the grout with a hammer. A hollow “popping” sound will indicate that the grout has de-bonded

from the marker or foundation and should be replaced.

Failed, loose sections of grout should be removed and replaced. Remove the loose grout using a hammer and chisel. Replace the missing grout with the standard grout mix used for new installations.

If a significant amount of the grout requires removal, the repair operation is generally beyond the scope of a cycle of general maintenance, and is therefore presented in detail in **Section 7.5.3**.

It is also important to consider the role of excessive moisture saturation as a cause of the deterioration. Standing water regularly collecting around or over the marker foundation is an indicator that drainage of the soil is a problem and could lead to saturation of the grout. To improve drainage around marker foundations existing soil should be excavated and replaced with free-draining granular fill protected by a water-permeable geotextile fabric. This operation is generally beyond the scope of a cycle of general maintenance, and is therefore presented in detail in **Section 7.5.1**.

5.4 Grave Surfaces

In Canada, Veterans' gravesites are surfaced either by gravel, or more commonly, by turfgrass. Although the maintenance of turfgrass is more labour intensive, gravel surfacing also requires recurring maintenance.

5.4.1 Gravel-surfaced Graves

Gravel is used as a grave surfacing in areas of the country that are inhospitable for growing turfgrass. Local gravel is the common surface material for graves in northern Manitoba, in parts of Newfoundland and Labrador, and in the high North. Regular inspections of a gravel-surfaced grave should look for any deterioration of the concrete grave margin, irregularities in the level of the grave surface, and any signs of weed species growing within the boundaries of the grave.

Concrete grave margins

Deterioration of the concrete grave margin can include hairline or larger cracks, and chipping or staining of the concrete. The inspector should make a note of the type of deterioration and the extent to which it has advanced. If a concrete grave margin has deteriorated to such an extent that the dignity of the Veteran's grave has been impaired, the margin should be replaced.

Uneven grave surfaces

The surface planes of graves should be relatively horizontal. Tipped or uneven grave surfaces can result from three causes that are relatively easy to fix during general maintenance activities:

- Most graves will settle during the first two years after they have been dug. To prevent the concrete grave margin from settling, it is recommended that the grave margin material rest on undisturbed soil. However, a tipped grave margin can be re-levelled by raising the lower parts, and placing gravel underneath them. Care should be taken during this process that the tools used to raise the grave margin do not mark, crack or chip the concrete, and that these tools provide sufficient leverage that no worker is in danger of

suffering muscle strain.

- The natural settlement of the grave during its first two years will cause the surface layer of gravel to be lowered below the top of the concrete grave margin. This creates a depression for water and ice to collect that could damage the grave margin during freeze-thaw cycles. Maintenance workers should expect to top up a new grave's surface with additional gravel immediately before freeze-up in the fall during each of its first two years, and occasionally thereafter.
- Burrowing animals or human vandals can also result in the unevenness of a grave's surface. Immediate and persistent replacement of gravel to ensure a level surface for the grave will eventually discourage two- and four-legged nuisances.

Weed growth

There are three recommended methods and one method to be avoided for dealing with weed growth on gravel surfaced Veterans' graves:

- The provision of a layer of landscape filter fabric (sometimes called landscape cloth) under the gravel of new graves, will cut down significantly on the amount of weed growth on the grave surface, while still allowing water to percolate into the soil.
- Cemeteries with gravel-surfaced Veterans' graves should be inspected twice a year, one month after spring thaw and just before freeze-up, for occasional weeds growing on top of graves. These occasional weeds can be pulled by hand using landscape forks to loosen plant roots. Every attempt should be made to remove the complete root, which should then be bagged to be composted elsewhere. If weeds are hard to remove, watering the grave surface will make the process easier. Where large numbers of Veterans' graves are involved, cemetery administration could turn a weeding day into a community event by offering refreshments to volunteers drawn from the local Royal Canadian Legion, Girl Guides and Boy Scouts or retiree groups. Increasingly, high school curricula include community service as a prerequisite for graduation, and such school programs are also a potential source of volunteer workers for simple tasks such as weeding graves.
- If regular inspections reveal a significant number of weeds appearing on grave surfaces, the layer of landscape filter fabric may be torn or absent. To replace the layer of filter fabric on an existing Veteran's grave, or to install it for the first time, remove all of the gravel over the grave, down to the level of the lower side of the concrete grave margin. Set the gravel aside for easy replacement by placing it on filter fabric to separate it from the adjacent unexcavated ground material. Next level the sub-grade with a rake, and place the landscape filter fabric so that all of the area of ground within the grave margin is covered. Replace the gravel, previously removed, over top of the filter fabric. If need be, top up the grave with additional gravel so that its surface is level with the topside of the concrete grave margin. Because landscape filter fabric will deteriorate if exposed to sunlight for extended periods of time, it is important to cover it with a layer of gravel 125 to 150 cm (5" to 6") thick.
- The ecology of areas where gravel-surfaced Veterans' graves are likely to be installed is

particularly fragile. At no time should chemical herbicides be used to remove weeds from gravel-surfaced graves.

5.4.2 Turfgrass

Grave Surfaces

By far the largest number of Veterans’ graves in Canada are surfaced with turfgrass that is regularly mown to present a neat green carpet which serves to focus attention on the grave marker as the main visible feature of the gravesite. Turfgrass is intended to be a background element framing the marker. However, if badly maintained, the grass becomes the first thing that visitors perceive. In order to promote healthy and visually pleasing turfgrass surfacing, the table below presents several of grass mixtures that will do well under the many different climatic conditions that occur within Canada. Although there may be other mixtures that can also flourish in the conditions listed, those presented in the table are widely and successfully used under the specific light/shade conditions of their respective plant hardiness zones.

Inspectors should ask the head groundskeeper for each cemetery in their territory for the type of grass mixture that is used for both over-seeding and for new sod in the areas used for Veterans’ burials. The information about these grass mixtures should be kept with the inspectors’ records for each cemetery.

Plant Hardiness Zone	Other Conditions	Grass Mix
Zones 1a to 2a	Sunny	50% Kentucky bluegrass (<i>Poa pratensis</i>) 40% creeping red fescue (<i>Festuca rubra rubra</i>) 10% annual ryegrass (<i>Lolium multiflorum</i>) Note: Annual ryegrass serves as a nurse crop for the first year until other grasses are established.
Zones 2b to 5b	Sunny	60% Kentucky bluegrass (<i>Poa pratensis</i>) 30% creeping red fescue (<i>Festuca rubra rubra</i>) 10% perennial ryegrass (<i>Lolium perenne</i>)
Zones 2b to 5b	Shade	70% creeping red fescue (<i>Festuca rubra rubra</i>) 20% Kentucky bluegrass (<i>Poa pratensis</i>) 10% perennial ryegrass (<i>Lolium perenne</i>)
Zones 6a to 8a	Sunny	60% perennial ryegrass (<i>Lolium perenne</i>) 30% creeping red fescue (<i>Festuca rubra rubra</i>) 10% Kentucky bluegrass (<i>Poa pratensis</i>)
Zones 6a to 8a	Shade	70% chewing fescue (<i>Festuca rubra commutata</i>) 30% perennial ryegrass (<i>Lolium perenne</i>)

Inspectors of Veterans’ gravesites should know the plant hardiness zones of the particular

cemeteries they cover. Regular inspections of cemeteries with Veterans' graves surfaced in turfgrass should look for a neat appearance resulting from regular mowing. They should record any deterioration of the plant material that could result in bare patches of soil or infestations of broad-leafed weeds.

Soil samples

Even if a cemetery displays flourishing turfgrass, once every six years inspectors should take a soil sample from the Veterans' area of every cemetery in their inspection territory for testing as to soil pH and nutrient requirements. Results of the soil tests should be kept on file to consult if problems arise, and should be shared with cemetery administrations.

Grass mowing

Although well-mown turfgrass is a pleasing surface treatment for any gravesite, the quality of the mowing is particularly important for Veterans' graves marked by flat stones. If grass mowing is done correctly it can also head off a lot of potential horticultural and resource conservation problems.

- Before mowing, the graves should be cleared of all debris such as paper or sticks.
- Frequency of mowing will vary throughout the growing season, so that only one-third of the grass blade is removed at any one cutting. The easy solution is to set a regular interval of mowing, for example once a week, or once every two weeks. However, a better end result is obtained, with greater economy of effort, when an observant grounds manager determines each time to mow according to the height of the grass.
- In order to discourage the growth of broad leaf weeds and to conserve moisture in the soil, the grass should not be cut shorter than 65 mm (2.5").
- Mower blades should be kept sharp throughout the growing season in order to cut cleanly.
- Grass clippings may be left on the surface of the turf unless their accumulation becomes thick enough to prevent air and water from reaching the soil.
- The grass around grave markers should be cut with string trimmers with nylon filaments, for approximately 150 mm (6") on all sides of the stones. The trimmers should be held on such an angle that the rotating nylon filament does not lash the surface of the grave marker. Similar care should be taken around the trunks of trees and shrubs.
- The wheels of mowers should never drive directly over flat grave markers. This applies to both ride-on and push mowers.
- Similarly, care should be taken that mowers do not bump into upright grave markers.
- Cemeteries with large numbers of flat markers often pass the cutting-decks of their ride-on mowers directly over the markers in order to cut grass immediately surrounding the stones without the need for string trimming. This is most likely to work without damaging the grave markers if two precautions are followed:

- Before cutting, the area to be mown should be inspected for any stones that rise above the surface of the ground, and these should then be levelled and re-set to be flush with the ground surface.
- Ride-on mowers with cutting decks that are connected to the mower tractor with a flexible attachment that permits movement of the deck on the vertical plane, independent of the mower, are less likely to scratch or gouge grave markers.

Fertilization

All living plant material requires nutrients to survive and flourish. Soil testing at five year intervals should be used to determine the need for grass fertilizers. However, the yearly application of top-dressing can be the primary means by which cemetery turfgrass receives nutriment.

- In early spring after raking and thatch removal, spread an even 12 mm layer of 1 part coarse sand to 2 parts manure or humus lightly over the surface of the lawn as a top-dressing. Composed humus is preferable to manure as a top dressing as it is less likely to burn roots or to give off unpleasant odours. Nevertheless, whichever source of nutrient is used the top dressing will be washed into the surface of the soil after one or two rainfalls, and will gradually penetrate to the active layer of the soil.
- In cemeteries with sandy soil, it may be necessary to provide a second application of top-dressing to the turfgrass in mid-summer.
- The soil tests will reveal any further nutrient requirements needed to produce healthy turfgrass.
- As a general rule it is better for the grass, and more economical to rely on slow release fertilizers to meet any nutrient requirements beyond top-dressing.
- Because cemeteries are often frequented by small children and pets, 'weed and feed' chemical fertilizers should be avoided.

Watering

Throughout much of Canada the months of July and August are accompanied by dry hot weather with little rainfall. In Western Canada it is common for lawns to be left to dry out, go dormant and turn brown, with the full knowledge that the autumn rains will cause the Kentucky blue grass to break its dormancy and turn green again. Because watering turfgrass in cemeteries will also accelerate the growth of biotic material on the grave markers, it is recommended that Veterans' gravesites adopt the Western Canadian tradition of lawn care, and water as little as possible. The only exception to this approach may be in cemeteries where perennial rye grass forms more than 50% of the turfgrass mix, because of that grass's high water requirements.

If a proposed water source has not been used before for landscape maintenance, it should be

tested for potability and pH value by a water-testing laboratory, and the results kept on file with the other inspection results for the cemetery. If problems arise in the turfgrass that cannot be explained by other means, the source of irrigation water should again be tested by a laboratory, and those results kept on file.

In general, if the subsoil of turfgrass areas receives a thorough soaking at least once a week during the growing season the grass will not enter dormancy and turn brown. A thorough soaking means that the soil under the grass receives moisture to a depth of 150 mm. If periods with dormant grass are not acceptable to cemetery administration, additional watering should only be instituted when natural rainfall does not provide this soaking. Sprinklers can deliver this additional watering, but care should be taken to try to wet the grave markers as little as possible. A simple tin can should be set out under the sprinkler to gauge the amount of precipitation the watering is actually supplying. By the time about 25 mm of water has accumulated in the tin can, the moisture should have penetrated the required 150 mm into the subsoil. A soil probe can be used to check the rate of penetration and the watering regime can be fine tuned from the results of the probe.

Weeding and over-seeding

Rather than using herbicides, broad-leaf weeds should be removed from the turfgrass surfaces by mechanical means. Avoiding the use of herbicides will protect grave markers from potential chemical damage, and will protect visitors and cemetery groundskeepers from potential health problems. The procedure for removing broad-leaf weeds from turfgrass is as follows:

- The turfgrass in areas of Veterans' burials should be checked for weeds before each mowing, and weed removal should be done before the mowing takes place.
- Weeds should be removed by hand using a gardening fork to loosen the soil before pulling. Care should be taken to ensure that the entire weed root is removed.
- If weed removal creates a noticeable bald spot in the lawn, this area can be over-seeded with a grass mixture to match the mixture of the surrounding turfgrass.
- Cover the seeded area with a 12 mm layer of peat moss, water daily, and protect from pedestrian traffic until the seeded area has sprouted and is ready to be mown.

Uneven grave surfaces

The surface planes of Veterans' graves covered with turfgrass should be relatively flat to enable the grass to be cut to the recommended height without creating bald patches in the turf. The natural settlement of a grave during its first two years will cause the surface layer of soil and grass to sink. This creates a saucer that allows water to accumulate and makes it difficult to provide a neat cutting for the grass covering the grave. Maintenance workers should expect to top up a new grave's surface with additional soil and to re-seed the surface in the spring and fall during each of its first two years, and occasionally thereafter. If older graves show settlement, they should also be topped up with soil and resurfaced with grass.

Tree roots Tree roots can grow large enough, particularly in the area near the base of the trunk known very descriptively as the root flare, to move grave markers out of alignment. Because the

cutting of such main roots will damage large portions of the canopy and perhaps even kill the tree, the best maintenance for this problem is prevention. When installing graves, care should be taken that they are not located within a two metre (6 ½ foot) radius of the tree trunk.

5.5 Inspection Schedules, Checklists and Procedures

All Veterans' gravesites in Canada should be inspected at least once every six years for the general conditions of their individual markers and foundations, and for their grave surfaces. Local conditions at some cemeteries, however, may result in the need to carry out inspections on a more frequent basis. Cemetery-wide conditions should also be noted as part of the inspection because larger scale problems such as site drainage, soil quality, and conditions of trees and shrubs can affect the durability of marker installations, the legibility of their inscriptions, and the dignity of Veterans' gravesites.

Individual marker conditions that should be noted as part of these recommended inspections include: problems with the legibility of the inscriptions, misalignment of the markers, damage to the markers and their foundations, and staining of the markers.

Grave surfacing conditions that should be noted include: any problems with the grave margin (for gravel-surfaced graves), settlement of the surface plane, grass mixes used for seeding and new sod, cutting height for grass, presence of broad-leafed weeds, and overall presentation of the gravesite.

Once every six years the inspectors should also take a soil sample from the VAC departmental plots and cemeteries in their inspection territory for testing for the following:

- soil pH,
- soil nutrient requirements,
- level of sulphates in soil (SO₄), and
- level of chlorides, nitrates, alkalies, iron and other minerals in soil.

VAC should encourage private sector gravesite providers to follow the same testing regime.

5.5.1 Inspection Checklists

Two checklists have been developed to assist inspectors in the collection of information:

- *Cemetery and Grave Surface Inspection Checklist*
- *Grave Marker Inspection Checklist.*

Both checklists are included in **Appendix B**. Photocopies should be made of these checklists for use during the inspections.

Cemetery and Grave Surface Inspection Checklist

The *Cemetery and Grave Surface Inspection Checklist* is intended to be used in examining the

parts of cemeteries that contain Veterans' gravesites, as well as for examining the surface conditions of individual graves. It permits the recording of data relevant to the cemetery wide problems, as well as landscape problems at individual graves. The *Cemetery and Grave Surface Inspection Checklist* is divided into three main parts:

- Part One provides space to record general data about the area of the cemetery where Veterans' graves are located, and about how they are surfaced. This information will typically remain unchanged from year to year as the inspections are completed, though some changes may be necessary if new grave markers are installed or changes are made to the cemetery. If information is available on the location of any unmarked graves this should also be noted as this knowledge would be beneficial for restoration work.
- Part Two provides space to record data specific to the symptoms of drainage, soil-related, and grave surface problems. This information may change from year to year as these areas of the cemetery are treated to solve the problems related to these symptoms.
- Part Three of the checklist is a series of information notes that provide additional data on the types of responses expected for parts one and two.

Grave Marker Inspection Checklist

The *Grave Marker Inspection Checklist* permits the recording of data related to the problems of a specific marker. This checklist should be completed for each marker installation that has problems associated with the legibility of the inscriptions, misalignment of the marker, damage to the marker or its foundation, or staining. The *Grave Marker Inspection Checklist* is divided into three main parts:

- Part One provides space to record general information about the marker. The collection of this information will require some investigative work including minor excavation as required to determine the connection type, foundation type, and the condition and size of the foundation.
- Part Two provides space to record data specific to symptoms present for the five main problem types: inscription legibility, marker misalignment, marker damage, staining, and general presentation of the marker. The symptoms were selected based on their visibility and relative ease of identification. After each symptom the Problem Identification Sheet [Pr/id] where this symptom is discussed is listed to aid the inspector in completing the problem identification.
- Part Three of the checklist is an area where the repair steps taken to treat the symptoms should be recorded with the date of the repair.

5.5.2 Inspection Procedures

In carrying out the inspection of the area within a cemetery with Veterans' gravesites, the *Cemetery and Grave Surface Inspection Checklist* should be completed for each of the areas.

In preparation for the first inspection of a cemetery, and when possible, the inspector should interview cemetery staff to obtain information on the maintenance history of the cemetery and to identify any significant issues or features of the cemetery that may not be obvious to the eye. On subsequent inspections, the inspector should review any records of repairs and maintenance activities for the intervening years between the current and the last inspection. The *Grave Marker Inspection Checklist* has been developed in such a way that the pertinent information on maintenance history of an individual marker can be recorded for just such a review.

For the inspection of the grave markers, the inspector should visually review each marker for evidence of problems with the legibility of its inscription, its alignment, damage to the marker or its foundation, staining, and foundation defects. As part of this review, all upright markers should be checked to determine if the marker / foundation connection is loose by pushing the marker back and forth by hand. When a marker is identified as having any of these problems to a degree that requires repair, the inspector should note these observations on the *Grave Marker Inspection Checklist*, completing a new checklist for each "problem" marker.

Most of the symptoms to be identified on the checklists are visual and require no further investigation. Misalignment, however, requires some additional investigation. If misalignment is an identified problem, the inspector should perform the following quick tests:

- For upright markers, determine if the marker / foundation connection is loose by pushing the marker back and forth by hand. If the marker moves easily, it should be considered loose.
- To acquire data about the foundation, carry out some minor excavation over and around the foundation to determine:
 - ❖ its condition (the extent of cracking and fracturing if any);
 - ❖ its type:
 - single marker foundation (a foundation that supports only one marker);
 - multiple marker (beam-on-grade) foundation (a foundation that is a concrete beam supported directly by the soil and which supports more than 1 marker); or
 - multiple marker (beam-on-piles) foundation (a foundation that is a concrete beam supported on concrete piles located at each end of the beam and which supports more than 1 marker); and
 - ❖ its approximate size.
- Determine the type of connection detail used between the marker and its foundation, and the condition of this connection. Common connections to the foundation include:

- marker cast-in-place (the marker set directly into the concrete of the foundation);
- marker set into a pocket or slot in the concrete foundation, and grouted in place;
- marker grouted between concrete bumpers of the foundation (the marker grouted or mortared into place between raised bumpers that have been cast onto the concrete foundation); and
- marker pinned to the concrete (metal rods connect the marker to its foundation).

After completing the inspection, the information on the *Grave Marker Inspection Checklist* should be compared with the problem identification sheets contained in **Section 6.0**. This will enable the inspector to identify the problems and the recommended repairs to treat them. To aid in this step, the Problem Identification Sheet [Pr/id] relevant to each symptom is identified by its number beside the symptom for quick reference.

All checklists should be retained and filed after the completion of the inspection, and reviewed prior to the start of each subsequent inspection. This will permit an accurate tracking of the problem types and repairs common at the cemetery, and will assist in the identification of long-term trends of specific problem types and the success or failure of specific repair techniques.

Appendix C

Guidelines for Taking Photos of Veteran Grave Markers

Camera

Pixels: No less than 2 mega-pixel
Format: JPG/JPEG format

Upright Markers

Upright grave markers should be taken in the "portrait mode" (440 pixels wide by 640 pixels high).

The marker should fill 75-85% of the frame. Ensure the foundation is visible in the photo.

Flat Markers

Flat markers should be taken in the "landscape mode" (640 pixels wide by 480 pixels high). The marker should fill 75-85% of the frame.



Tips

Water may be sprayed on the stone to bring out the inscription.

Avoid getting your shadow on the marker; however, in cases of glare it may be necessary to shadow out the entire marker.

Saving Photos

1. Download images from the camera to the computer.
2. Copy the images from the computer to CD(s) or memory stick.
3. Mail CD(s) or memory stick to:

Robin Hewitt

Cemetery Maintenance
P.O. Box 7700 (1B304)
Charlottetown, PE
C1A 8M9

Phone: (902) 370-7101
Fax: (902) 566-8501
Cell: (902) 388-4737
E-mail: robin.hewitt@canada.ca

4. Keep a digital copy of the image for your files, in case the CD/memory stick is lost or damaged in shipping.

Annex B

Basis of Payment

- Goods to be delivered FOB destination.
- The Bidder must provide individual prices for each item and/or destination. Failure to do so will render bid non-responsive.
- Pricing excludes applicable taxes.

1.Mount Olivet Cemetery, Halifax, Nova Scotia				
Marker Type	Work Requirements	Quantity	Price / Marker	Cost Estimate
Upright Granite	Clean	37		
Upright Granite	Clean& align	8		
Upright Granite	Align	1		
Upright Granite	Supply and install new base foundation, install existing marker and clean	2		
Upright Granite	Supply and install new marker with base foundation	4		
Flat Granite	Clean	68		
Flat Granite	Clean & align	9		
Flat Granite	Align	1		
Flat Granite	Supply and install new base foundation and clean and install existing marker	1		
Flat Granite	Flat Granite – Supply and install new marker	10		
A	Subtotal Total			
B*	5% contingency			
C	Total			

2.Gate of Heaven Cemetery - Lower Sackville, Nova Scotia				
Marker Type	Work Requirements	Quantity	Price/ Marker	Cost Estimate
Upright Granite	Clean	51		
Upright Granite	Clean& align	63		
Upright Granite	Clean & grout	2		

Upright Granite	Clean & sink foundation	1		
Upright Granite	Grout to base	2		
Upright Granite	Align	37		
Upright Granite	Supply and install new base foundation and install existing marker	1		
Upright Granite	Supply and install new base foundation, install existing marker and clean	9		
Upright Granite	Supply and install new marker with foundation	4		
Flat Granite	Clean	68		
Flat Granite	Clean & align	56		
Flat Granite	Clean & sink foundation	1		
Flat Granite	Sink foundation	1		
Flat Granite	Align	31		
Flat Granite	Supply and install new marker	27		
Upright Granite Laid Flat	Clean	9		
Upright Granite Laid Flat	Clean & align	2		
Upright Granite Laid Flat	Supply and install new base foundation, install existing marker and clean	6		
A	Subtotal Total			
B*	5% contingency			
C	Total			

Fiscal Year 2019-2020

3.Camp Hill Cemetery - Halifax Nova Scotia				
Marker Type	Work Requirements	Quantity	Price/Marker	Cost Estimate
Upright Granite	Clean	76		
Upright Granite	Clean& align	25		
Upright Granite	Clean & sink foundation	5		

Upright Granite	Align	1		
Upright Granite	Clean, align, trim shrubs	1		
Upright Granite	Supply and install new base foundation and install existing marker	1		
Upright Granite	Supply and install new base foundation, install existing marker and clean	7		
Upright Granite	Supply and install new marker with foundation	3		
Flat Granite	Clean	76		
Flat Granite	Clean & align	25		
Flat Granite	Clean & sink foundation	5		
Flat Granite	Clean & trim shrubs	1		
Flat Granite	Trim shrubs	1		
Flat Granite	Align	9		
Flat Granite	Supply and install new base foundation and clean and install existing marker	7		
Flat Granite	Supply and install new marker and base foundation	3		
Upright Granite Laid Flat	Supply and install new base foundation, install existing marker and clean	1		
A	Subtotal Total			
B*	5% contingency			
C	Total			

4.St. John's Cemetery and Columbarium – Halifax, Nova Scotia				
Marker Type	Work Requirements	Quantity	Price Per Marker	Cost Estimate
Upright Granite	Clean	48		
Upright Granite	Clean& align	2		
Upright Granite	Clean & sink foundation	1		

Upright Granite	Supply and install new base foundation and install existing marker	5		
Upright Granite	Supply and install new base foundation, install existing marker and clean	2		
Upright Granite	Supply and install new marker with foundation	1		
Flat Granite	Clean	14		
Flat Granite	Clean & align	1		
Flat Granite	Clean & sink foundation	1		
Flat Granite	Supply and install new marker and base foundation	5		
A	Subtotal Total			
B*	5% contingency			
C	Total			

Total amount for each cemetery – Line C		
1.Mount Olivet Cemetery	C	
2.Gate of Heaven Cemetery	C	
3.Camp Hill Cemetery	C	
4.St. John’s Cemetery and Columbarium	C	
Total for four cemeteries		

Total per Fiscal Year	
2018-2019	
2019-2020	
Total	

B* - In addition to the above detailed work, if there are issues that arise as a result of complications when trying to align, replace, grout, trim shrubs or repair markers, it is beneficial to have a contingency fund associated with this contract that would cover necessary repairs, replacement markers and base foundations. Prior to commencing any additional work or purchasing new markers or bases, the Project Authority must be contacted and give authority to proceed with the repairs or replacement. This amount is not to exceed the additional 5% + HST per cemetery listed.