



Procurement and Contracting Services
30 Victoria Street
Gatineau, Quebec K1A 0M6

REQUEST FOR PROPOSAL AMENDMENT

The Request for Proposal is hereby amended; unless otherwise indicated, all other terms and conditions of the Request for Proposal remain the same.

RFP Amendment No. 1	RFP Amendment Date: August 21, 2018
Office of the Chief Electoral Officer File No. ECLP-RFP-18-0335	
Title: Various Poll Bags	
Request for Proposal Closing Date: September 25, 2018 at 2:00 p.m. (Gatineau time)	
ENQUIRIES – address enquiries to the Contracting Authority: Office of the Chief Electoral Officer of Canada Procurement and Contracting Services 30 Victoria Street Gatineau, Quebec K1A 0M6 proposition-proposal@elections.ca	
Attention: Luc Potvin	Email: proposition-proposal@elections.ca

Part 1. Interpretation

- 1.1** Elections Canada hereby amends in accordance with this amendment the Request for Proposal bearing number ECLP-RFP-18-0335 and dated August 10, 2018 (the “RFP”). This amendment hereby forms part of the RFP.
- 1.2** Unless defined herein or unless the context otherwise requires, all of the words and phrases defined in the RFP and used in this amendment shall have the same meanings assigned to them in the RFP.

Part 2. Questions and Answers

The following question(s) have been asked in response to the Request for Proposal and Elections Canada hereby answers as follows:

2.1 Question No. 1

Question:

Is it one time delivery?

Answer:

Yes, as specified in the specifications we will accept partial deliveries as long as the entire quantity is delivered by November 28th, 2018.

2.2 Question No. 2

Question:

Is it one point delivery address?

Answer:

Yes. As specified in the specifications: Delivery to 100 - 440 Coventry Road, Ottawa, ON.

2.3 Question No. 3

Question:

Can we submit samples after closing date upon request?

Answer:

Samples are not required at this time however the winning bidder must provide proofs/samples before production.

2.4 Question No. 4

Question:

Could you please give me the back photo of flap line item 01 bag for my reference? I want to confirm the structure of flap exactly.

Answer:

Please see attached PDF files for technical drawings of the bags.

2.5 Question No. 5

Question:

Please confirm if we can have samples of each style of the various bags so we can verify the quality of material for costing or if we can view samples at Montreal office.

Answer:

Samples of EC 50480, EC 50490 and EC 50500 are available and will be provided upon request. As for EC 50390, EC 50516 and EC 50517, samples are not available as these bags are new productions. Note: Samples that can be provided are not exactly as requested in the specifications, size and text are different.

2.6 Question No. 6

Question:

I noticed Items EC50500 and EC50390 uses 5mil HDPE. Can you please confirm if EC50490, EC50480, EC50517, and EC50516 use 0.5mil HDPE or all the items supposed to use 5mil, and the period is just a typo?

Answer:

All bags must be of High density polyethylene **5mil** plastic and not .5mil as stipulated in the specifications.

Please see Part 3 – Amendments below.

2.7 Question No. 7

Question:

Also there are some technical issues on the given production information. For example the thickness of 5mil, 2 ply is 10mil, and for bags with gusset, total will be 4 ply / 20mil, which is very hard to heat seal.

Answer:

These bags have been produced before and there was no issue on the heat seal.

Part 3. Amendments

3.1 Amendment to Annex A – Statement of Work of the Request for Proposal

The Request for Proposal is hereby amended by deleting in its entirety **Annex A – Statement of Work** and replacing it with the attached **Annex A – Statement of Work** (Revised August 17, 2018).



Various Poll Bags

ANNEX A – STATEMENT OF WORK

REVISED 2018-08-17

SPECIFICATIONS

DESCRIPTION OF DELIVERABLE:	Plastic security bag with grey opaque inside and yellow colour on the exterior
REFERENCE NUMBER:	EC 50500 (05/2018)
TITLE:	Ordinary Poll Bag - yellow
QUANTITY:	100,000
OVER:	<i>No over / No under</i> Elections Canada will not pay an invoice for items received in excess of the quantity stipulated in this specification, nor will it pay the full amount when items are sent in lower quantities than requested. It is the supplier's responsibility to ensure that items are shipped in the correct quantities.
SIZE:	<ul style="list-style-type: none">• Metric: 46 cm long plus 7 cm flap. Total length with flap 53 cm x 37 cm wide open end plus 10.2 cm gusset.• Imperial: 18" long plus 2 ¾" flap. Total length with flap 20 ¾" x 14 ½" wide open end. (plus 4" gusset).
STYLE:	<ul style="list-style-type: none">• Gusset: 10.2 cm (4") at the bottom• Air Holes: Plastic bag must have 2 half-moon air holes at the bottom, one on the left side and one on the right side
FLAP:	The 7 cm (2 ¾") flap must have one strip of 2 cm wide x 37 cm long (¾" wide x 14. ½" long) of a D transfer tape applied at 1 cm (3/8") from the top of the flap.
PRINTING:	Prints two colours PMS 120C Yellow for bag – bleeds all sides Text: Black one side no bleed – front only. Print quality – Informational
INK:	PMS 120C Yellow for entire outside body of bag – bleeds all sides. Black for text
STOCK:	High density polyethylene 5mil plastic – Co-extruded white outside,

grey opaque inside.

PRODUCTION:

Camera Ready Copy has to be set up printing flat length wise 99cm long x37cm wide (38 ¾” long x 14.5” wide) plus 10.2cm (4”) gusset

IMAGE:

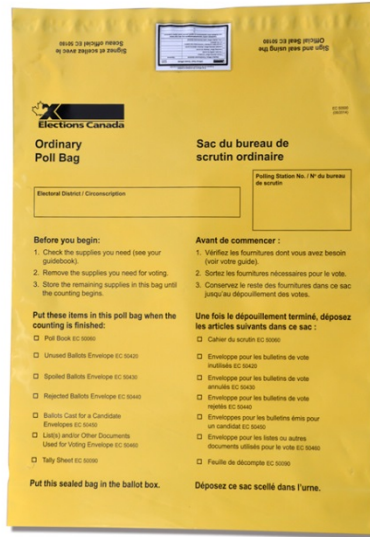

NOTE: IMAGE FOR INFORMATION PURPOSE ONLY

PROOF:

One proof is required for approval before production. Please send to Elections Canada, Material Management, OFG Directorate, 30 Victoria Street, Gatineau QC. K1A 0M6.
Attention Diane Lemay

PACKAGING:

Package flat 100 per corrugated box. Each box not to weigh more than 35 lbs. Clearly identify each box as to content in a minimum 20 pt. type size.

Label on Boxes:

EC 50500 (05/2018)
Ordinary Poll Bag - Yellow /
Sac du bureau de scrutin ordinaire - jaune
Qty/Qté 100

NOTE : Labeling of items going to the Distribution Centre must be exactly as indicated. If not, they will not be accepted

QUOTE SUBMISSION:

Your quotation must show cost per unit and must include the cost of:

- printing plates (if applicable);

- skids; and
- transportation fee.
- .

MANDATORY DELIVERY DATES:

On or before November 28th, 2018
Upon approval by the contracting or technical authority partial deliveries will be accepted but entire quantity must be delivered by November 28th, 2018.

SHIPPING INSTRUCTIONS:

Ship on non-returnable shipping skids 48" wide by 42" deep not to exceed 54" high stacking height. The material must be accessible by hand held hydraulic pallet movers.

SKIDS:

Brewery type skid – 4 way entry type, 48" wide by 42" deep, 3 stringers with three blocks, each running 48" long

NOTE: Items shipped to the Distribution Centre not on requested skids will not be accepted upon delivery.

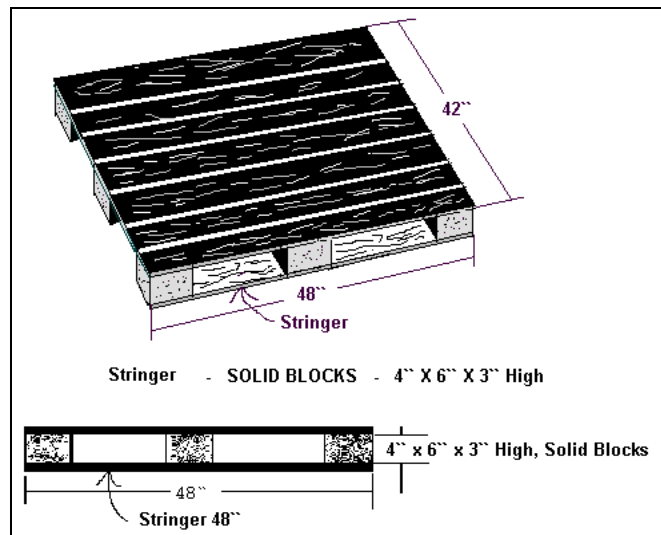

HOURS OF OPERATION :
(Ottawa time)

8 a.m. to 12:00 noon / 1:00 p.m. to 4:00 p.m.

DESTINATION:

Elections Canada Distribution Centre
100-440 Coventry Road, Ottawa, Ontario K1K 2Y5

INVOICING:

Please send your invoice to the following address:

Jocelyne Leroux
Material Management, OFG
Elections Canada
30 Victoria Street
Gatineau, Quebec K1A 0M6

Or by e-mail:

gestiondumatérielSGF-materialmanagementSMS@elections.ca

It is the responsibility of the supplier to provide a valid tax registration number for: HST/GST and QST, as applicable. Elections Canada will not validate tax registration numbers. If applicable sales taxes are invoiced without a tax registration number(s), Elections Canada will not pay the applicable sales tax(es).

Invoices must indicate the Contract number, if applicable, the Reference Number, the revision date and show any correction cost breakdown as applicable

ADDITIONAL INFORMATION:

No change in these specifications will be accepted unless approved by the project authority.

Elections Canada must be informed of the cost of any author's alterations as soon as possible. A contract amendment must be made as soon as any changes affecting cost occur.

The printer is to return to Elections Canada a final electronic file properly identified with all or any corrections made at the proofing stage before invoices are approved for payment.

Wrapping and shipping instructions must be followed to the letter or the Distribution Centre may refuse to accept the shipment.

DESCRIPTION OF DELIVERABLE:	Plastic security bag white with grey opaque inside
REFERENCE NUMBER:	EC 50390 (05/2018)
TITLE:	Office documents bag
QUANTITY:	160,000
OVER:	<i>No over / No under</i> Elections Canada will not pay an invoice for items received in excess of the quantity stipulated in this specification, nor will it pay the full amount when items are sent in lower quantities than requested. It is the supplier's responsibility to ensure that items are shipped in the correct quantities
SIZE:	<ul style="list-style-type: none">• Metric: 46 cm long plus 7 cm flap. Total length with flap 53 cm x 37 cm wide open end plus a 10.2 cm gusset• Imperial: 18" long plus 2 ¾" flap. Total length with flap 20 ¾" x 14 ½" wide open end (plus a 4" gusset).
STYLE:	<ul style="list-style-type: none">• Gusset: 10.2 cm (4") at the bottom.• Air Holes: Plastic bag must have 2 half-moon air holes at the bottom, one on the left side and one on the right side.
FLAP:	The 7 cm (2 ¾") flap must have one strip of 2 cm wide x 37 cm long (¾" wide x 14 ½" long) of a D transfer tape applied at 1 cm (3/8" from the top of the flap.
PRINTING:	Prints two colours white for bag – bleeds all sides. Text: Black one side no bleed – front only. Print quality – Informational.
INK:	White for entire outside body of bag – bleeds all sides Black for text.
STOCK:	High density polyethylene 5mil plastic – Co-extruded white outside, grey opaque inside.
PRODUCTION:	Camera Ready Copy has to be set up printing flat length wise 99 cm long x 37 cm wide (38 ¾" long x 14 ½" wide plus 10.2 cm (4") gusset.

PROOF: One proof is required for approval before production. Please send to Elections Canada, Material Management, OFG Directorate, 30 Victoria Street, Gatineau QC. K1A 0M6 Attention: Diane Lemay

PACKAGING: Package flat 100 per corrugated box. Each box not to weight more than 35 lbs. Clearly identify each box as to content in a minimum 20 pt. Type size.

Label on Boxes

<p><i>EC 50390 (05/2018)</i> <i>Office documents Bag</i> <i>Sac de documents de bureau</i> <i>Qty/Qté 100</i></p>

NOTE: Labelling of items going to the Distribution Centre must be exactly as indicated. If not, they will not be accepted.

QUOTE SUBMISSION: Your quotation must show cost per unit and must include the cost of:

- printing plates (if applicable);
- skids; and
- transportation fee.

MANDATORY DELIVERY DATE: **On or before, November 28th, 2018**
Upon approval by the contracting or Technical authority, partial deliveries will be accepted, but entire quantity must be delivered by November 28th 2018

SHIPPING INSTRUCTIONS: Ship on non-returnable shipping skids 48" wide by 42" deep not to exceed 54" high stacking height. The material must be accessible by hand held hydraulic pallet movers.

SKIDS:

Brewery type skid – 4 way entry type, 48" wide by 42" deep, 3 stringers with three blocks, each running 48" long

NOTE: Items shipped to the Distribution Centre not on requested skids will not be accepted upon delivery.

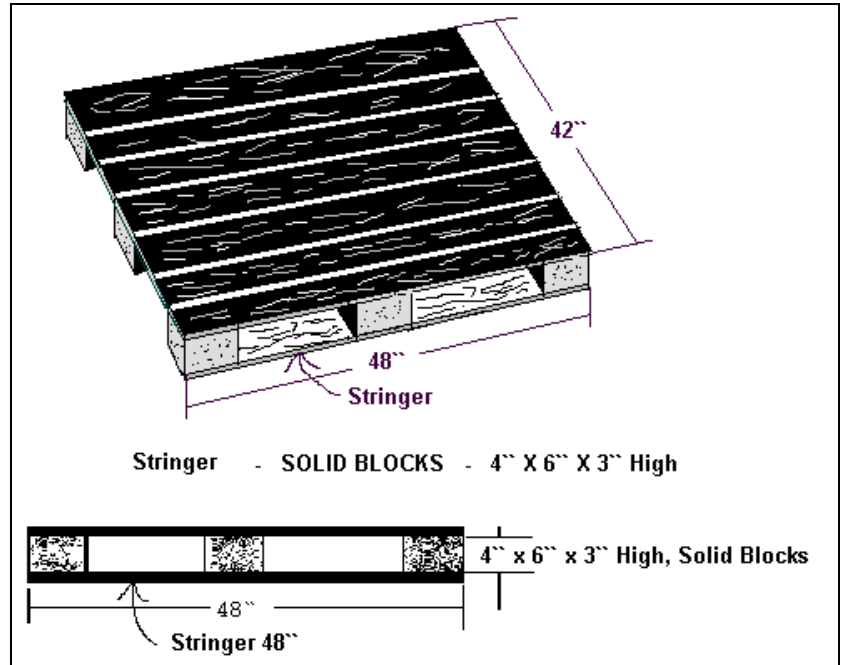

HOURS OF OPERATION:
(Ottawa time)

8 a.m. to 12:00 noon / 1:00 p.m. to 4:00 p.m.

DESTINATION:

Elections Canada Distribution Centre
100-440 Coventry Road, Ottawa, Ontario K1K 2Y5

INVOICE:

Please send your invoice to the following address:

Jocelyne Leroux
Material Management, OFG
30 Victoria Street
Gatineau, Québec K1A 0M6

Or by e-mail:

gestiondumatérielSGF-materialmanagementSMS@elections.ca

It is the responsibility of the supplier to provide a valid tax

registration number for: HST, GST and QST, as applicable. Elections Canada will not validate tax registration numbers. If applicable taxes are invoiced without a tax registration number(s), Elections Canada will not pay the applicable tax(es).

Invoices must indicate the Purchase Order number, if applicable, the Reference Number, the revision date and show any correction cost breakdown whenever it is applicable.

ADDITIONAL INFORMATION:

No change in these specifications will be accepted unless approved by the project authority.

Elections Canada must be informed of the cost of any author's alterations as soon as possible. A contract amendment must be made as soon as any changes affecting cost occur.

The printer is to return to Elections Canada a final electronic file properly identified with all or any corrections made at the proofing stage before invoices are approved for payment.

Wrapping and shipping instructions must be followed to the letter or the Distribution Centre may refuse to accept the shipment.

DESCRIPTION OF DELIVERABLE:	Plastic security bag with grey opaque inside and light violet colour on the exterior.
REFERENCE NUMBER:	EC 50490 (05/2018)
TITLE:	Mobile Poll Bag – Light Violet
QUANTITY:	7,500
OVER:	<i>No over / No under</i> Elections Canada will not pay an invoice for items received in excess of the quantity stipulated in this specification, nor will it pay the full amount when items are sent in lower quantities than requested. It is the supplier's responsibility to ensure that items are shipped in the correct quantities.
SIZE:	<ul style="list-style-type: none">• Metric: 46 cm long plus 7 cm flap. Total length with flap 53 cm x 37 cm wide open end plus 10.2cm gusset• Imperial: 18" long plus 2 ¾" flap. Total length with flap 20 ¾" x 14 ½" wide open end (plus 4" gusset).
STYLE:	<ul style="list-style-type: none">• Gusset: 10.2 cm (4") at the bottom• Air Holes: Plastic bag must have 2 half- moon air holes at the bottom, one on the left side and one on the right side
FLAP:	The 7 cm (2 ¾") flap must have one strip of 2 cm wide x 37 cm long (¾" wide x 14 ½" long) of a D transfer tape applied at 1 cm (3/8") from the top of the flap.
PRINTING:	Prints two colours PMS 2645C -Light violet for bag– bleeds all sides Text: Black one side no bleed – Front only Print quality – Informational
INK:	PMS 2645C – Light Violet for entire outside body of bag – bleeds all sides. Black for text.
STOCK:	High density polyethylene 5mil plastic – Co-extruded white outside,

grey opaque inside.

PRODUCTION:

Camera Ready Copy has to be set up printing flat length wise 99 cm long x 37 cm wide (38 ¾” long x 14 ½” wide) plus 10.2cm (4”) gusset.

IMAGE:

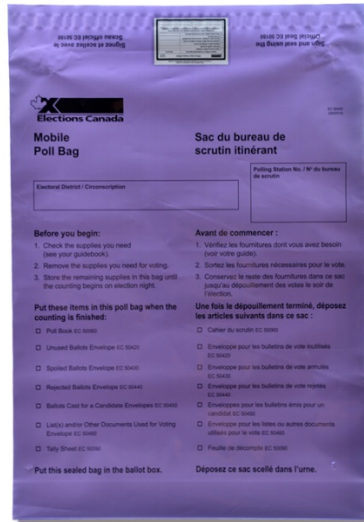

NOTE: IMAGE FOR INFORMATION PURPOSE ONLY

PROOF:

One proof is required for approval before production. Please send to Elections Canada, OFG Directorate, 30 Victoria Street, Gatineau QC. K1A 0M6.

Attention: Diane Lemay

PACKAGING:

Package flat 100 per corrugated box. Each box not to weigh more than 35 lbs. Clearly identify each box as to content in a minimum 20 pt. type size.

Label on Boxes:

EC 50490 (05/2018)
Mobile Poll Bag – Light Violet /
Sac du bureau de scrutin itinérant – Violet pâle
Qty/Qté 100

NOTE : Labeling of items going to the Distribution Centre must be exactly as indicated. If not, they will not be accepted.

MANDATORY DELIVERY DATE:

On or before November 28th, 2018

Upon approval by the contracting or technical authority partial deliveries will be accepted but entire quantity must be delivered

by November 28th, 2018.

SHIPPING INSTRUCTIONS:

Ship on non-returnable shipping skids 48" wide by 42" deep not to exceed 54" high stacking height. The material must be accessible by hand held hydraulic pallet movers.

SKIDS:

Brewery type skid – 4 way entry type, 48" wide by 42" deep, 3 stringers with three blocks, each running 48" long

NOTE: Items shipped to the Distribution Centre not on requested skids will not be accepted upon delivery.

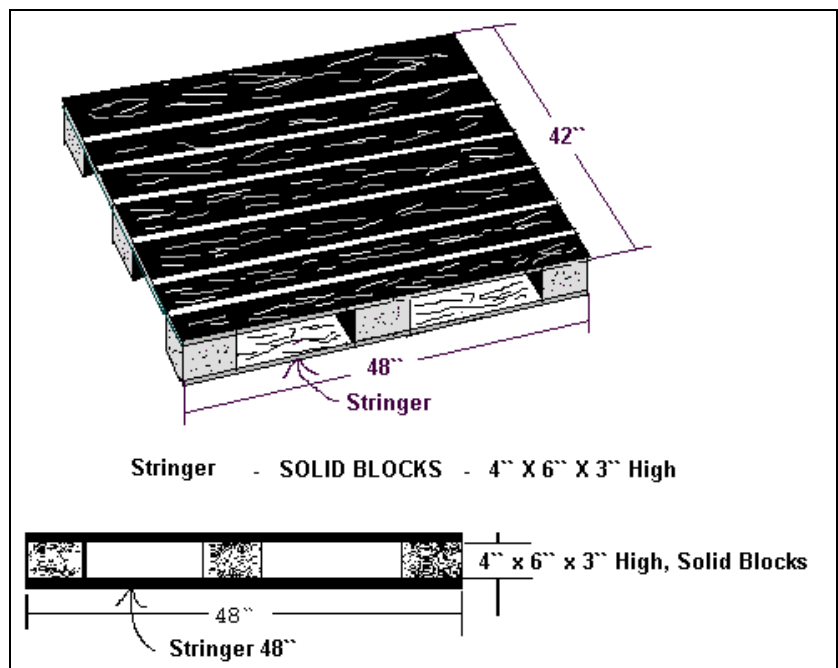

HOURS OF OPERATION :
(Ottawa time)

8 a.m. to 12:00 noon / 1:00 p.m. to 4:00 p.m.

DESTINATION:

*Elections Canada Distribution Centre
100-440 Coventry Road, Ottawa, Ontario K1K 2Y5*

INVOICING:

Please send your invoice to the following address:

Jocelyn Leroux
Material Management, OFG
Elections Canada
30 Victoria Street
Gatineau, Quebec K1A 0M6

Or by e-mail:

gestiondumatérielSGF-materialmanagementSMS@elections.ca

It is the responsibility of the supplier to provide a valid tax registration number for: HST/GST and QST, as applicable. Elections Canada will not validate tax registration numbers. If applicable sales taxes are invoiced without a tax registration number(s), Elections Canada will not pay the applicable sales tax(es).

Invoices must indicate the Contract number, if applicable, the Reference Number, the revision date and show any correction cost breakdown as applicable.

ADDITIONAL INFORMATION:

No change in these specifications will be accepted unless approved by the project authority.

Elections Canada must be informed of the cost of any author's alterations as soon as possible. A contract amendment must be made as soon as any changes affecting cost occur.

The printer is to return to Elections Canada a final electronic file properly identified with all or any corrections made at the proofing stage before invoices are approved for payment.

Wrapping and shipping instructions must be followed to the letter or the Distribution Centre may refuse to accept the shipment.

DESCRIPTION OF DELIVERABLE:	Plastic security bag with grey opaque inside and light green colour on the exterior
REFERENCE NUMBER:	EC 50480 (05/2018)
TITLE:	Advance Poll Bag – light green
QUANTITY:	12,000
OVER:	<i>No over / No under</i> Elections Canada will not pay an invoice for items received in excess of the quantity stipulated in this specification, nor will it pay the full amount when items are sent in lower quantities than requested. It is the supplier's responsibility to ensure that items are shipped in the correct quantities.
SIZE:	<ul style="list-style-type: none">• Metric: 46 cm long plus 7 cm flap. Total length with flap 53 cm x 37 cm wide open end (plus 10.2cm gusset)• Imperial: 18" long plus 2 ¾" flap. Total length with flap 20 ¾" x 14 ½" wide – open end. (plus 4" gusset)
STYLE:	<ul style="list-style-type: none">• Gusset: 10.2 cm (4") at the bottom• Air Holes: Plastic bag must have 2 half-moon air holes at the bottom, one on the left side and one on the right side
FLAP:	The 7 cm (2 ¾") flap must have one strip 2 cm wide x 37 cm long (¾" wide x 14 ½" long) of a D transfer tape applied at 1 cm (3/8") from the top of the flap.
PRINTING:	Prints two colours PMS 2253C Light Green for bag – bleeds all sides Text: Black one side no bleed – front only. Print quality – Informational
INK:	PMS 2253C Light green for entire outside body of bag – bleeds all sides. Black for text
STOCK:	High density polyethylene 5mil plastic – Co-extruded white outside,

grey opaque inside

PRODUCTION:

Camera Ready Copy has to be set up printing flat length wise 99cm long x 37cm wide (38 ¾” long x 14 ½” wide), plus 10.2 cm (4”) gusset.

IMAGE:

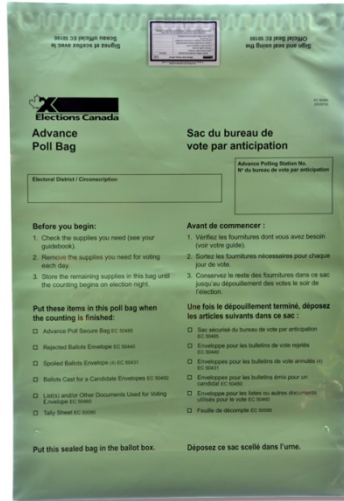

NOTE: IMAGE FOR INFORMATION PURPOSE ONLY

PROOF:

One proof is required for approval before production. Please send to Elections Canada, Material Management, OFG, 30 Victoria Street, Gatineau QC. K1A 0M6.
Attention: Diane Lemay.

PACKAGING:

Package flat 100 per corrugated box. Each box not to weigh more than 35 lbs. Clearly identify each box as to content in a minimum 20 pt. type size.

Label on Boxes:

EC 50480 (05/2018)
*Advance Poll Bag – Light Green/
SAC du bureau de vote par anticipation – vert pâle*
Qty/Qté 100

NOTE : Labeling of items going to the Distribution Centre must be exactly as indicated. If not, they will not be accepted.

QUOTE SUBMISSION:

Your quotation must show cost per unit and must include the cost of:

- printing plates (if applicable);
- skids; and

- transportation fee.

MANDATORY DELIVERY DATE: **On or before November 28th, 2018**
Upon approval by the contracting or technical authority partial deliveries will be accepted but entire quantity must be delivered by November 28th, 2018

SHIPPING INSTRUCTIONS: Ship on non-returnable shipping skids 48" wide by 42" deep not to exceed 54" high stacking height. The material must be accessible by hand held hydraulic pallet movers.

SKIDS: Brewery type skid – 4 way entry type, 48" wide by 42" deep, 3 stringers with three blocks, each running 48" long

NOTE: Items shipped to the Distribution Centre not on requested skids will not be accepted upon delivery.

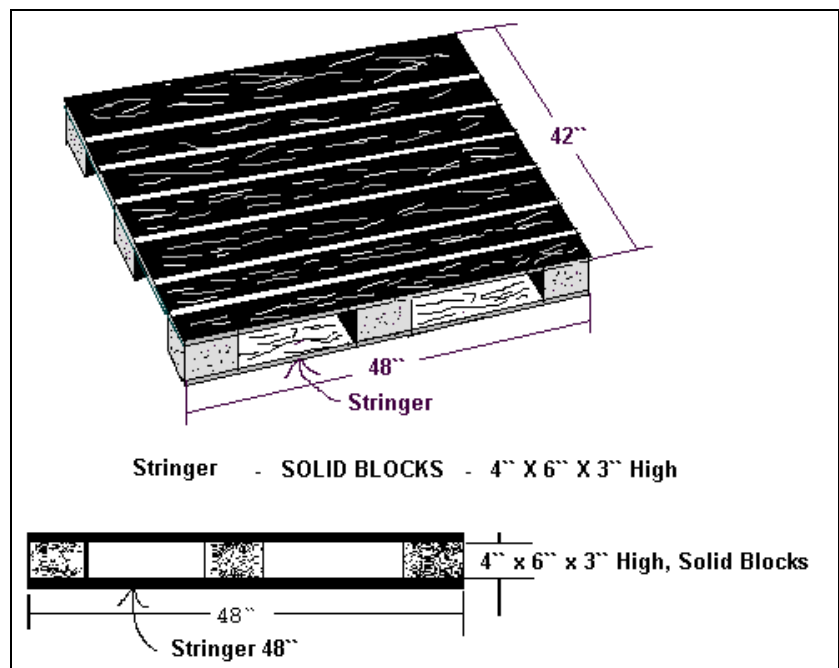

HOURS OF OPERATION : 8 a.m. to 12:00 noon / 1:00 p.m. to 4:00 p.m.
(Ottawa time)

DESTINATION: Elections Canada Distribution Centre
100-440 Coventry Road, Ottawa, Ontario K1K 2Y5

INVOICING:

Please send your invoice to the following address:

Jocelyne Leroux
Material management - OFG
Elections Canada
30 Victoria Street,
Gatineau, Quebec K1A 0M6

Or by e-mail:

gestiondumatérielSGF-materialmanagementSMS@elections.ca

It is the responsibility of the supplier to provide a valid tax registration number for: HST/GST and QST, as applicable. Elections Canada will not validate tax registration numbers. If applicable sales taxes are invoiced without a tax registration number(s), Elections Canada will not pay the applicable sales tax(es).

Invoices must indicate the Contract number, if applicable, the Reference Number, the revision date and show any correction cost breakdown as applicable

ADDITIONAL INFORMATION:

No change in these specifications will be accepted unless approved by the project authority.

Elections Canada must be informed of the cost of any author's alterations as soon as possible. A contract amendment must be made as soon as any changes affecting cost occur.

The printer is to return to Elections Canada a final electronic file properly identified with all or any corrections made at the proofing stage before invoices are approved for payment.

Wrapping and shipping instructions must be followed to the letter or the Distribution Centre may refuse to accept the shipment.

DESCRIPTION OF DELIVERABLE:	Clear Plastic Bag.
REFERENCE NUMBER:	EC 50517 (05/2018)
TITLE:	Ordinary Poll Site Bag
QUANTITY:	28,000
OVER:	<i>No over / No under</i> Elections Canada will not pay an invoice for items received in excess of the quantity stipulated in this specification, nor will it pay the full amount when items are sent in lower quantities than requested. It is the supplier's responsibility to ensure that items are shipped in the correct quantities.
SIZE:	<ul style="list-style-type: none">• Metric: 46 cm long plus 7 cm flap. Total length with flap 53 cm x 37 cm wide open end plus a 10.2 cm gusset)• Imperial: 18" long plus 2 ¾" flap. Total length with flap 20 ¾" x 14 ½" wide – open end. (plus 4" gusset)•
STYLE:	<ul style="list-style-type: none">• Gusset: 10.2 cm or 4" gusset at the bottom• Air Holes: Plastic bag must have 2 half- moon holes at the bottom, one on the left side and one on the right side
FLAP:	The 7 cm (2 ¾") flap has one strip 2 cm wide x 37 cm long (¾" wide x 14 ½" long) of a D transfer tape applied at 1cm (3/8") from the top of the flap.
PRINTING:	Text: Black one side no bleed – front only. Print quality – Informational
INK:	Black for text.
STOCK:	High density polyethylene 5mil clear plastic
PRODUCTION:	Camera Ready Copy has to be set up printing flat length wise 99 cm long x 37 cm wide (38 ¾" long x 14 ½" wide)

PROOF:

One proof is required for approval before production. Please send to:

Elections Canada,
Material Management, OFG
30 Victoria Street,
Gatineau QC K1A 0M6
Attention: Diane Lemay

PACKAGING:

Ship flat 100 per corrugated box. Each box not to weigh more than 35 lbs. Clearly identify each box as to content in a minimum 20 pt. type size.

Label on Boxes:

<p><i>EC 50517 (05/2018)</i> <i>Ordinary Poll Site Bag /</i> <i>Sac du lieu de scrutin ordinaire</i> <i>Qty/Qté 100</i></p>

NOTE : Labeling of items going to the Distribution Centre must be exactly as indicated. If not, they will not be accepted.

QUOTE SUBMISSION:

Your quotation must show cost per unit and must include the cost of:

- printing plates (if applicable);
- skids; and
- transportation fee.

MANDATORY DELIVERY DATE:

On or before November 28th, 2018.

Upon approval by the contracting or technical authority partial deliveries will be accepted but entire quantity must be delivered by November 28th, 2018.

SHIPPING INSTRUCTIONS:

Ship on non-returnable shipping skids 48" wide by 42" deep not to exceed 54" high stacking height. The material must be accessible by hand held hydraulic pallet movers.

SKIDS:

Brewery type skid – 4 way entry type, 48" wide by 42" deep, 3 stringers with three blocks, each running 48" long

NOTE: Items shipped to the Distribution Centre not on requested

skids will not be accepted upon delivery.

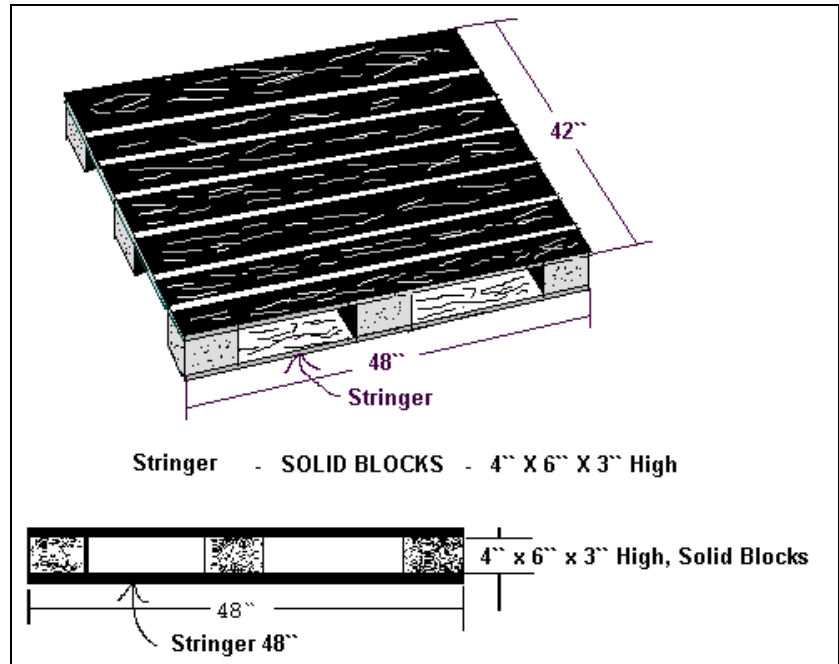

HOURS OF OPERATION:
(Ottawa time)

8 a.m. to 12:00 noon / 1:00 p.m. to 4:00 p.m.

DESTINATION:

Elections Canada Distribution Centre
100-440 Coventry Road, Ottawa, Ontario K1K 2Y5

INVOICING:

Please send your invoice to the following address:

Jocelyne Leroux
Material Management, OFG
Elections Canada
30 Victoria Street,
Gatineau, Quebec K1A 0M6

Or by e-mail:

gestiondumatérielSGF-materialmanagementSMS@elections.ca

It is the responsibility of the supplier to provide a valid tax registration number for: HST/GST and QST, as applicable. Elections Canada will not validate tax registration numbers. If applicable sales taxes are invoiced without a tax registration number(s), Elections Canada will not pay the

applicable sales tax(es).

Invoices must indicate the Contract number, if applicable, the Reference Number, the revision date and show any correction cost breakdown as applicable

ADDITIONAL INFORMATION:

No change in these specifications will be accepted unless approved by the project authority.

Elections Canada must be informed of the cost of any author's alterations as soon as possible. A contract amendment must be made as soon as any changes affecting cost occur.

The printer is to return to Elections Canada a final electronic file properly identified with all or any corrections made at the proofing stage before invoices are approved for payment.

Wrapping and shipping instructions must be followed to the letter or the Distribution Centre may refuse to accept the shipment.

DESCRIPTION OF DELIVERABLE:	Clear Plastic Bag.
REFERENCE NUMBER:	EC 50516 (05/2018)
TITLE:	Advance Poll Site Bag
QUANTITY:	12,000
OVER:	<i>No over / No under</i> Elections Canada will not pay an invoice for items received in excess of the quantity stipulated in this specification, nor will it pay the full amount when items are sent in lower quantities than requested. It is the supplier's responsibility to ensure that items are shipped in the correct quantities.
SIZE:	<ul style="list-style-type: none">• Metric: 46 cm long plus 7 cm flap. Total length with flap 53 cm x 37 cm wide open end (plus 10.2 cm gusset)• Imperial: 18" long plus 2 ¾" flap. Total length with flap 20 ¾" x 14 ½" wide – open end. (plus 4" gusset)
STYLE:	<ul style="list-style-type: none">• Gusset: 10.2 cm or 4" gusset at the bottom• Air Holes: Plastic bag must have 2 half- moon holes at the bottom, one on the left side and one on the right side
FLAP:	The 7 cm (2 ¾") flap has one strip 2 cm wide x 37 cm long (¾" wide x 14 ½" long) of a D transfer tape applied at 1cm (3/8") from the top of the flap.
PRINTING:	Text: Black one side no bleed – front only. Print quality – Informational
INK:	Black for text.
STOCK:	High density polyethylene 5mil clear plastic
PRODUCTION:	Camera Ready Copy has to be set up printing flat length wise 99 cm long x 37 cm wide (38 ¾" long x 14 ½" wide) plus 4" gusset.

PROOF:

One proof is required for approval before production. Please send to:

Elections Canada,
Material Management, OFG
30 Victoria Street,
Gatineau QC K1A 0M6
Attention: Diane Lemay

PACKAGING:

Ship flat 100 per corrugated box. Each box not to weigh more than 35 lbs. Clearly identify each box as to content in a minimum 20 pt. type size.

Label on Boxes:

<p><i>EC 50516 (05/2018)</i> <i>Advance Poll Site Bag /</i> <i>Sac du lieu de vote par anticipation</i> <i>Qty/Qté 100</i></p>

NOTE : Labeling of items going to the Distribution Centre must be exactly as indicated. If not, they will not be accepted.

QUOTE SUBMISSION:

Your quotation must show cost per unit and must include the cost of:

- printing plates (if applicable);
- skids; and
- transportation fee.

MANDATORY DELIVERY DATE:

On or before November 28th, 2018.

Upon approval by the contracting or technical authority partial deliveries will be accepted but entire quantity must be delivered by November 28th, 2018.

SHIPPING INSTRUCTIONS:

Ship on non-returnable shipping skids 48" wide by 42" deep not to exceed 54" high stacking height. The material must be accessible by hand held hydraulic pallet movers.

SKIDS:

Brewery type skid – 4 way entry type, 48" wide by 42" deep, 3 stringers with three blocks, each running 48" long

NOTE: Items shipped to the Distribution Centre not on requested

skids will not be accepted upon delivery.

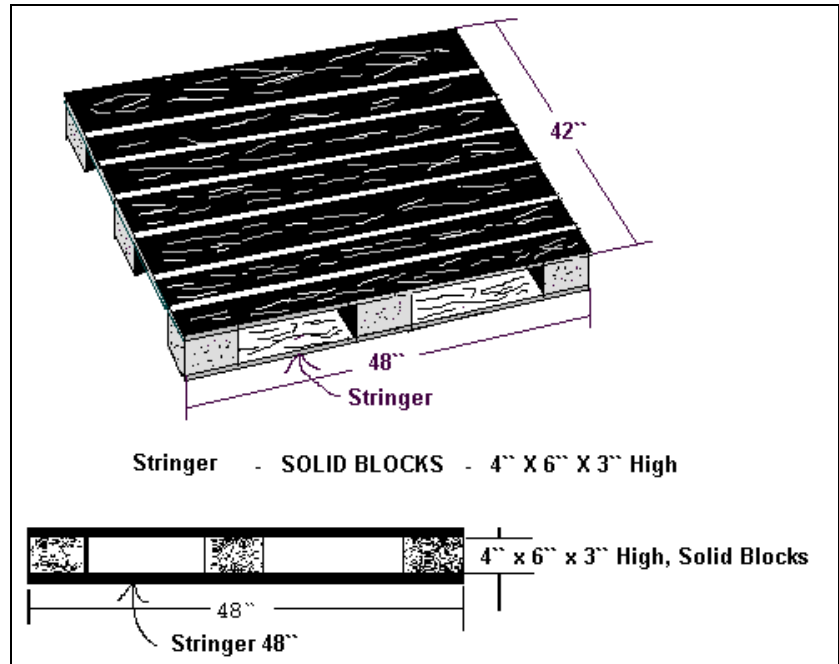

HOURS OF OPERATION:
(Ottawa time)

8 a.m. to 12:00 noon / 1:00 p.m. to 4:00 p.m.

DESTINATION:

Elections Canada Distribution Centre
100-440 Coventry Road, Ottawa, Ontario K1K 2Y5

INVOICING:

Please send your invoice to the following address:

Jocelyne Leroux
Material Management, OFG
Elections Canada
30 Victoria Street,
Gatineau, Quebec K1A 0M6

Or by e-mail:

gestiondumatérielSGF-materialmanagementSMS@elections.ca

It is the responsibility of the supplier to provide a valid tax registration number for: HST/GST and QST, as applicable. Elections Canada will not validate tax registration numbers. If applicable sales taxes are invoiced without a tax registration number(s), Elections Canada will not pay the

applicable sales tax(es).

Invoices must indicate the Contract number, if applicable, the Reference Number, the revision date and show any correction cost breakdown as applicable

ADDITIONAL INFORMATION:

No change in these specifications will be accepted unless approved by the project authority.

Elections Canada must be informed of the cost of any author's alterations as soon as possible. A contract amendment must be made as soon as any changes affecting cost occur.

The printer is to return to Elections Canada a final electronic file properly identified with all or any corrections made at the proofing stage before invoices are approved for payment.

Wrapping and shipping instructions must be followed to the letter or the Distribution Centre may refuse to accept the shipment.

ECLP-RFP-18-0335 Various Poll Bags

EC 50500 (05/2018) – Ordinary Poll Bag – yellow

Signez et scellez avec le
Scellé officiel EC 50180



Sign and seal using the
Official Seal EC 50180



EC 50500
(05/2018)

Ordinary Poll Bag

Purpose: To store and transport the voting material and to securely store some material after the count.

Sac du bureau de scrutin ordinaire

Objectif : Conserver et transporter le matériel électoral, et conserver de façon sécuritaire certains documents après le dépouillement.

Electoral District / Circonscription	Polling Station No. / N° du bureau de scrutin
--------------------------------------	-----------------------------------------------

Refer to your guidebook for instructions on how to use the material in this bag.

Consultez votre guide pour savoir comment utiliser le matériel dans ce sac.



.....

14-1/2"

2-3/4"

18"

4"

18"

3-1/4"

ECLP-RFP-18-0335 Various Poll Bags

EC 50390 (05/2018) – Office documents bag – white

Signez et scellez avec le
Sceau officiel EC 50180

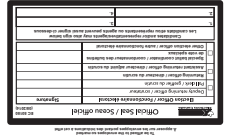

Official Seal/EC 50180
Sign and seal using the



Office documents Bag
Purpose: To securely transport some certificates, forms and envelopes collected during the day for processing at the office.

EC 50390
(05/2018)

Sac de documents de bureau
Objectif : Transporter de façon sécuritaire des certificats, des formulaires et des enveloppes recueillis pendant la journée, aux fins de traitement au bureau.

Electoral District / Circonscription	Polling Station No. N° du bureau de scrutin	Day / Jour <input type="checkbox"/> Friday / vendredi <input type="checkbox"/> Monday / lundi <input type="checkbox"/> Saturday / samedi <input type="checkbox"/> Election day / jour du scrutin <input type="checkbox"/> Sunday / dimanche
--------------------------------------	------------------------------------------------	------------------------------------------------------------------------------------------------------------------------------------------------------------------------------------------------------------------------------------------------------

<p>At the end of the day, count the number of each certificate/form and write the number here:</p>	<p>À la fin de la journée, comptez les certificats et les formulaires puis inscrivez le nombre ici :</p>
----------------------------------------------------------------------------------------------------	----------------------------------------------------------------------------------------------------------

	<table border="1" style="margin: auto;"> <tr> <th style="padding: 2px;"># of certificates/forms # de certificats et de formulaires</th> </tr> <tr> <td style="height: 20px;"></td> </tr> <tr> <td style="height: 20px;"></td> </tr> <tr> <td style="height: 20px;"></td> </tr> </table>	# of certificates/forms # de certificats et de formulaires				
# of certificates/forms # de certificats et de formulaires						

<p>EC 50050 Registration Certificates</p> <p>EC 50051 Voting Status Certificates</p> <p>EC 50055 Oath of Residence Form</p>	<p>EC 50050 Certificats d'inscription</p> <p>EC 50051 Certificats du statut de vote</p> <p>EC 50055 Formulaires de déclaration de résidence sous serment</p>	
-----------------------------------------------------------------------------------------------------------------------------	--------------------------------------------------------------------------------------------------------------------------------------------------------------	--

<p>You do not need to count the other documents.</p>	<p>Vous n'avez pas à compter les autres documents.</p>
------------------------------------------------------	--------------------------------------------------------

14-1/2"
 2-3/4"
 18"
 3-1/4"
 18"

ECLP-RFP-18-0335 Various Poll Bags

EC 50490 (05/2018) – Mobile Poll Bag – light violet

14-1/2"

Signez et scellez avec le
Sceau officiel EC 50180

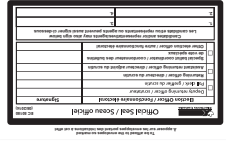

Official Seal/EC 50180
Sign and seal using the



Mobile Poll Bag
Purpose: To store and transport the voting material and to securely store some material after the count.

EC 50490
(05/2018)

Sac du bureau de scrutin itinérant
Objectif : Conserver et transporter le matériel électoral, et conserver de façon sécuritaire certains documents après le dépouillement.

Electoral District / Circonscription	Polling Station No. / N° du bureau de scrutin
--------------------------------------	-----------------------------------------------

Refer to your guidebook for instructions on how to use the material in this bag.

Consultez votre guide pour savoir comment utiliser le matériel dans ce sac.



.....

18"

3-3/4"

18"

3-3/4"

