



**Procurement and Contracting Services**  
30 Victoria Street  
Gatineau, Quebec K1A 0M6

## REQUEST FOR PROPOSAL AMENDMENT

The Request for Proposal is hereby amended; unless otherwise indicated, all other terms and conditions of the Request for Proposal remain the same.

<b>RFP Amendment No.</b>  4	<b>RFP Amendment Date:</b>  September 6, 2018
<b>Office of the Chief Electoral Officer File No.</b>  ECLP-RFP-18-0335	
<b>Title:</b>  Various Poll Bags	
<b>Request for Proposal Closing Date:</b>  September 25, 2018 at 2:00 p.m. (Gatineau time)	
<b>ENQUIRIES – address enquiries to the Contracting Authority:</b>  <b>Office of the Chief Electoral Officer of Canada</b> Procurement and Contracting Services 30 Victoria Street Gatineau, Quebec K1A 0M6  proposition-proposal@elections.ca	
<b>Attention:</b>  Luc Potvin	<b>Email:</b>  proposition-proposal@elections.ca

## **Part 1. Interpretation**

- 1.1** Elections Canada hereby amends in accordance with this amendment the Request for Proposal bearing number ECLP-RFP-18-0335 and dated August 10, 2018 (the “RFP”). This amendment hereby forms part of the RFP.
- 1.2** Unless defined herein or unless the context otherwise requires, all of the words and phrases defined in the RFP and used in this amendment shall have the same meanings assigned to them in the RFP.

## **Part 2. Questions and Answers**

The following question(s) have been asked in response to the Request for Proposal and Elections Canada hereby answers as follows:

### **2.1 Question No. 12**

Question:

I received the samples EC 50480, EC 50490 and EC 50500 thank you.

For the texting please confirm if the format is the same and only the item number may change

Ex: EC50500 (08/2014) will change to (05/2018)

Please also note that on your tender you request Gusset 4” wide but sample received are 3”. Please confirm if we follow tender or samples for size.

As for items # EC 50390, EC 50516 and EC 50517

For the above missing sample all details such as size: style, flap, stock, production seems to be same as above samples except for INK and printing which is printed black on Opaque clear Bag

Can you confirm if the white printed patch next to “sign and seal using the Official Seal EC 50180” on flap is also required for the clear bags?

Answer:

- a) The samples provided are for information only. The text and reference number on each bag are different and a “ready-to-print” PDF file will be supplied to the winning bidder.
- b) Suppliers must follow the size indicated in Annex A – Statement of work of the tender. Do not use the samples provided to prepare your quotation.
- c) The white printed patch is required on the clear plastic bag and on all coloured bags.

## **Part 3. Amendments**

### **3.1 Amendment to Annex A – Statement of Work of the Request for Proposal**

The Request for Proposal is hereby amended by deleting in its entirety **Annex A – Statement of Work** and replacing it with the attached **Annex A – Statement of Work** (Revised September 5, 2018).



## Various Poll Bags

---

### ANNEX A – STATEMENT OF WORK

**REVISED 2018-09-05**

<b>SPECIFICATIONS</b>
-----------------------

<b>DESCRIPTION OF DELIVERABLE:</b>	Plastic security bag with grey opaque inside and yellow colour on the exterior
<b>REFERENCE NUMBER:</b>	<b>EC 50500 (05/2018)</b>
<b>TITLE:</b>	Ordinary Poll Bag - yellow
<b>QUANTITY:</b>	100,000
<b>OVER:</b>	<b>No over / No under</b> Elections Canada will not pay an invoice for items received in excess of the quantity stipulated in this specification, nor will it pay the full amount when items are sent in lower quantities than requested. It is the supplier's responsibility to ensure that items are shipped in the correct quantities.
<b>SIZE:</b>	<ul style="list-style-type: none"><li>• Metric: 46 cm long plus 7 cm flap. Total length with flap 53 cm x 37 cm wide open end plus 10.2 cm gusset.</li><li>• Imperial: 18" long plus 2 ¾" flap. Total length with flap 20 ¾" x 14 ½" wide open end. (plus 4" gusset).</li></ul>
<b>STYLE:</b>	<ul style="list-style-type: none"><li>• <b>Gusset:</b> 10.2 cm (4") at the bottom</li><li>• <b>Air Holes:</b> Plastic bag must have 2 half-moon air holes at the bottom, one on the left side and one on the right side</li></ul>
<b>FLAP:</b>	The 7 cm (2 ¾") flap must have one strip of 2 cm wide x 37 cm long (¾" wide x 14. ½" long) of a D transfer tape applied at 1 cm (3/8") from the top of the flap.
<b>PRINTING:</b>	Prints two colours PMS 120C Yellow for bag – bleeds all sides Text: Black one side no bleed – front only. <b>The square on the front of the flap indicating the placement of the Official Seal must remain white.</b> Print quality – Informational
<b>INK:</b>	PMS 120C Yellow for entire outside body of bag – bleeds all sides. Black for text <b>The square on the front of the flap must remain white.</b>
<b>STOCK:</b>	High density polyethylene 5mil plastic – Co-extruded white outside, grey opaque inside.

**COMPONANT:**

Camera Ready file supplied is prepared flat lengthwise including the gusset and flap. The supplier is not required to do additional set up with the PDF, nor any typesetting.

**IMAGE:**

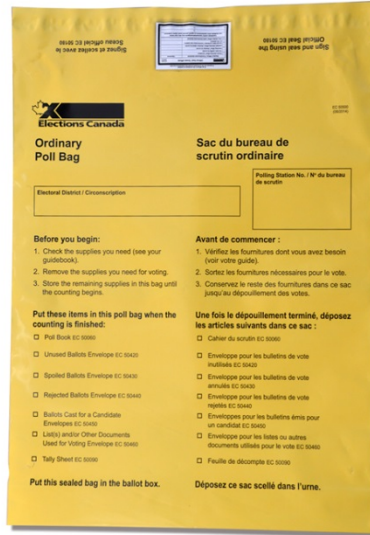

**NOTE: IMAGE FOR INFORMATION PURPOSE ONLY**

**PROOF:**

One proof is required for approval before production. Please send to Elections Canada, Material Management, OFG Directorate, 30 Victoria Street, Gatineau QC. K1A 0M6. Attention Diane Lemay

**PACKAGING:**

Package flat 100 per corrugated box. Each box not to weigh more than 35 lbs. Clearly identify each box as to content in a minimum 20 pt. type size.

**Label on Boxes:**

**EC 50500 (05/2018)**  
**Ordinary Poll Bag - Yellow /**  
**Sac du bureau de scrutin ordinaire - jaune**  
**Qty/Qté 100**

**NOTE :** Labeling of items going to the Distribution Centre must be exactly as indicated. If not, they will not be accepted

**QUOTE SUBMISSION:**

Your quotation must show cost per unit and must include the cost of:  
- printing plates (if applicable);

- skids; and
- transportation fee.

**MANDATORY DELIVERY DATES:**

**On or before November 28th, 2018**

**Upon approval by the contracting or technical authority partial deliveries will be accepted but entire quantity must be delivered by November 28<sup>th</sup>, 2018.**

**SHIPPING INSTRUCTIONS:**

Ship on non-returnable shipping skids 48" wide by 42" deep not to exceed 54" high stacking height. The material must be accessible by hand held hydraulic pallet movers.

**SKIDS:**

Brewery type skid – 4 way entry type, 48" wide by 42" deep, 3 stringers with three blocks, each running 48" long

**NOTE:** Items shipped to the Distribution Centre not on requested skids will not be accepted upon delivery.

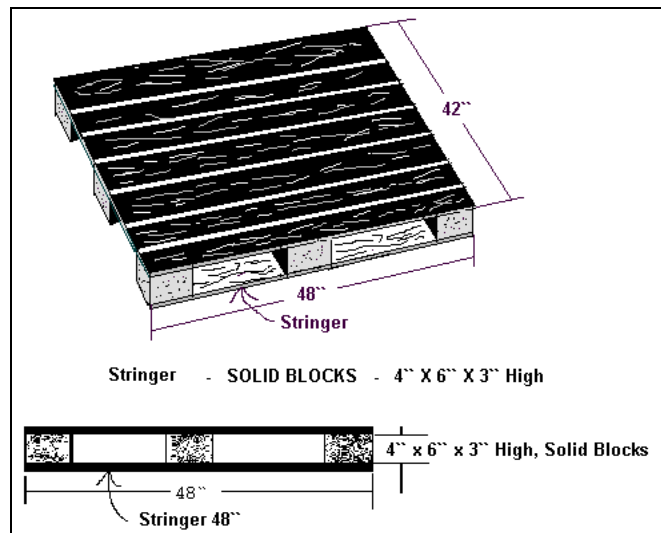

**HOURS OF OPERATION :**  
**(Ottawa time)**

8 a.m. to 12:00 noon / 1:00 p.m. to 4:00 p.m.

**DESTINATION:**

Elections Canada Distribution Centre  
100-440 Coventry Road, Ottawa, Ontario K1K 2Y5

**INVOICING:**

Please send your invoice to the following address:

Jocelyne Leroux  
Material Management, OFG  
Elections Canada  
30 Victoria Street  
Gatineau, Quebec K1A 0M6

Or by e-mail:

[gestiondumatérielSGF-materialmanagementSMS@elections.ca](mailto:gestiondumatérielSGF-materialmanagementSMS@elections.ca)

It is the responsibility of the supplier to provide a valid tax registration number for: HST/GST and QST, as applicable. Elections Canada will not validate tax registration numbers. If applicable sales taxes are invoiced without a tax registration number(s), Elections Canada will not pay the applicable sales tax(es).

**Invoices must indicate the Contract number, if applicable, the Reference Number, the revision date and show any correction cost breakdown as applicable**

**ADDITIONAL INFORMATION:**

**No change in these specifications will be accepted unless approved by the project authority.**

Elections Canada must be informed of the cost of any author's alterations as soon as possible. A contract amendment must be made as soon as any changes affecting cost occur.

The printer is to return to Elections Canada a final electronic file properly identified with all or any corrections made at the proofing stage before invoices are approved for payment.

Wrapping and shipping instructions must be followed to the letter or the Distribution Centre may refuse to accept the shipment. Plastic security bag with grey opaque inside and yellow colour on the exterior



<b>DESCRIPTION OF DELIVERABLE:</b>	Plastic security bag white with grey opaque inside
<b>REFERENCE NUMBER:</b>	<b>EC 50390 (05/2018)</b>
<b>TITLE:</b>	Office documents bag
<b>QUANTITY:</b>	160,000
<b>OVER:</b>	<b><i>No over / No under</i></b> Elections Canada will not pay an invoice for items received in excess of the quantity stipulated in this specification, nor will it pay the full amount when items are sent in lower quantities than requested. It is the supplier's responsibility to ensure that items are shipped in the correct quantities
<b>SIZE:</b>	<ul style="list-style-type: none"><li>• Metric: 46 cm long plus 7 cm flap. Total length with flap 53 cm x 37 cm wide open end plus a 10.2 cm gusset</li><li>• Imperial: 18" long plus 2 ¾" flap. Total length with flap 20 ¾" x 14 ½" wide open end (plus a 4" gusset).</li></ul>
<b>STYLE:</b>	<ul style="list-style-type: none"><li>• <b>Gusset:</b> 10.2 cm (4") at the bottom.</li><li>• <b>Air Holes:</b> Plastic bag must have 2 half-moon air holes at the bottom, one on the left side and one on the right side.</li></ul>
<b>FLAP:</b>	The 7 cm (2 ¾") flap must have one strip of 2 cm wide x 37 cm long (¾" wide x 14 ½" long) of a D transfer tape applied at 1 cm (3/8" from the top of the flap.
<b>PRINTING:</b>	Prints two colours white for bag – bleeds all sides. Text: Black one side no bleed – front only. Print quality – Informational.
<b>INK:</b>	White for entire outside body of bag – bleeds all sides Black for text.
<b>STOCK:</b>	High density polyethylene 5 mil plastic – Co-extruded white outside, grey opaque inside.
<b>COMPONENT:</b>	<b>Camera Ready file supplied is prepared flat lengthwise including the gusset and flap. The supplier is not required to do additional set up with the PDF, nor any typesetting.</b>

**PROOF:** One proof is required for approval before production. Please send to Elections Canada, Material Management, OFG Directorate, 30 Victoria Street, Gatineau QC. K1A 0M6 Attention: Diane Lemay

**PACKAGING:** Package flat 100 per corrugated box. Each box not to weight more than 35 lbs. Clearly identify each box as to content in a minimum 20 pt. Type size.

**Label on Boxes**

<p><b><i>EC 50390 (05/2018)</i></b> <i>Office documents Bag</i> <i>Sac de documents de bureau</i> <i>Qty/Qté 100</i></p>
--

**NOTE:** Labelling of items going to the Distribution Centre must be exactly as indicated. If not, they will not be accepted.

**QUOTE SUBMISSION:** Your quotation must show cost per unit and must include the cost of:

- printing plates (if applicable);
- skids; and
- transportation fee.

**MANDATORY DELIVERY DATE:** **On or before, November 28<sup>th</sup>, 2018**  
**Upon approval by the contracting or Technical authority, partial deliveries will be accepted, but entire quantity must be delivered by November 28<sup>th</sup> 2018**

**SHIPPING INSTRUCTIONS:** Ship on non-returnable shipping skids 48" wide by 42" deep not to exceed 54" high stacking height. The material must be accessible by hand held hydraulic pallet movers.

**SKIDS:**

Brewery type skid – 4 way entry type, 48" wide by 42" deep, 3 stringers with three blocks, each running 48" long

**NOTE:** Items shipped to the Distribution Centre not on requested skids will not be accepted upon delivery.

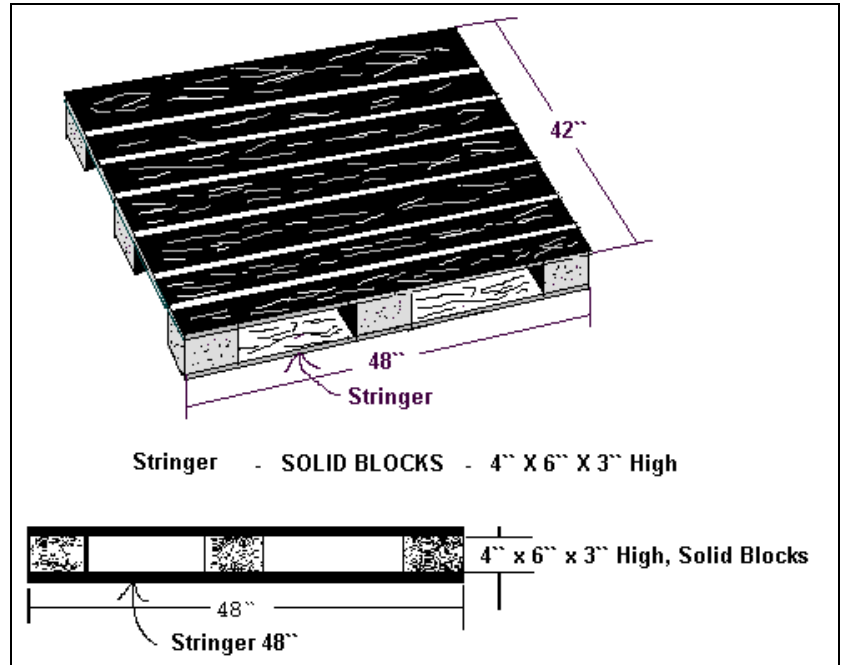

**HOURS OF OPERATION:**  
(Ottawa time)

8 a.m. to 12:00 noon / 1:00 p.m. to 4:00 p.m.

**DESTINATION:**

Elections Canada Distribution Centre  
100-440 Coventry Road, Ottawa, Ontario K1K 2Y5

**INVOICE:**

Please send your invoice to the following address:

Jocelyne Leroux  
Material Management, OFG  
30 Victoria Street  
Gatineau, Québec K1A 0M6

Or by e-mail:

[gestiondumatérielSGF-materialmanagementSMS@elections.ca](mailto:gestiondumatérielSGF-materialmanagementSMS@elections.ca)

It is the responsibility of the supplier to provide a valid tax

registration number for: HST, GST and QST, as applicable. Elections Canada will not validate tax registration numbers. If applicable taxes are invoiced without a tax registration number(s), Elections Canada will not pay the applicable tax(es).

**Invoices must indicate the Purchase Order number, if applicable, the Reference Number, the revision date and show any correction cost breakdown whenever it is applicable.**

**ADDITIONAL INFORMATION:**

**No change in these specifications will be accepted unless approved by the project authority.**

of the cost of any author's alterations as soon as possible. A contract amendment must be made as soon as any changes affecting cost occur.

The printer is to return to Elections Canada a final electronic file properly identified with all or any corrections made at the proofing stage before invoices are approved for payment.

Wrapping and shipping instructions must be followed to the letter or the Distribution Centre may refuse to accept the shipment.

<b>DESCRIPTION OF DELIVERABLE:</b>	Plastic security bag with grey opaque inside and light violet colour on the exterior.
<b>REFERENCE NUMBER:</b>	<b>EC 50490 (05/2018)</b>
<b>TITLE:</b>	Mobile Poll Bag - Light Violet
<b>QUANTITY:</b>	7,500
<b>OVER:</b>	<b><i>No over / No under</i></b> Elections Canada will not pay an invoice for items received in excess of the quantity stipulated in this specification, nor will it pay the full amount when items are sent in lower quantities than requested. It is the supplier's responsibility to ensure that items are shipped in the correct quantities.
<b>SIZE:</b>	<ul style="list-style-type: none"><li>• Metric: 46 cm long plus 7 cm flap. Total length with flap 53 cm x 37 cm wide open end plus 10.2cm gusset</li><li>• Imperial: 18" long plus 2 ¾" flap. Total length with flap 20 ¾" x 14 ½" wide open end (plus 4" gusset).</li></ul>
<b>STYLE:</b>	<ul style="list-style-type: none"><li>• <b>Gusset:</b> 10.2 cm (4") at the bottom</li><li>• <b>Air Holes:</b> Plastic bag must have 2 half- moon air holes at the bottom, one on the left side and one on the right side</li></ul>
<b>FLAP:</b>	The 7 cm (2 ¾") flap must have one strip of 2 cm wide x 37 cm long (¾" wide x 14 ½" long) of a D transfer tape applied at 1 cm (3/8") from the top of the flap.
<b>PRINTING:</b>	Prints two colours PMS 2645C -Light violet for bag– bleeds all sides Text: Black one side no bleed – Front only <b>The square on the front of the flap indicating the placement of the Official Seal must remain white.</b> Print quality – Informational
<b>INK:</b>	PMS 2645C – Light Violet for entire outside body of bag – bleeds all sides. Black for text.

The square on the front of the flap must remain white

**STOCK:**

High density polyethylene 5mil plastic – Co-extruded white outside, grey opaque inside.

**COMPONANT:**

Camera Ready file supplied is prepared flat lengthwise including the gusset and flap. The supplier is not required to do additional set up with the PDF, nor any typesetting.

**IMAGE:**

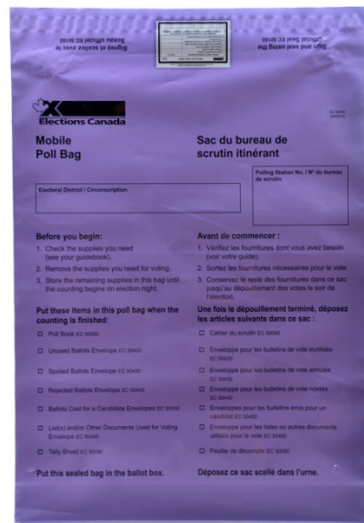

**NOTE: IMAGE FOR INFORMATION PURPOSE ONLY**

**PROOF:**

One proof is required for approval before production. Please send to Elections Canada, OFG Directorate, 30 Victoria Street, Gatineau QC. K1A 0M6.

Attention: Diane Lemay

**PACKAGING:**

Package flat 100 per corrugated box. Each box not to weigh more than 35 lbs. Clearly identify each box as to content in a minimum 20 pt. type size.

**Label on Boxes:**

**EC 50490 (05/2018)**  
*Mobile Poll Bag – Light Violet /*  
*Sac du bureau de scrutin itinérant – Violet pâle*  
*Qty/Qté 100*

**NOTE :** Labeling of items going to the Distribution Centre must be exactly as indicated. If not, they will not be accepted.

**MANDATORY DELIVERY DATE:** **On or before November 28<sup>th</sup>, 2018**  
**Upon approval by the contracting or technical authority partial deliveries will be accepted but entire quantity must be delivered by November 28<sup>th</sup>, 2018.**

**SHIPPING INSTRUCTIONS:** Ship on non-returnable shipping skids 48" wide by 42" deep not to exceed 54" high stacking height. The material must be accessible by hand held hydraulic pallet movers.

**SKIDS:** Brewery type skid – 4 way entry type, 48" wide by 42" deep, 3 stringers with three blocks, each running 48" long

**NOTE:** Items shipped to the Distribution Centre not on requested skids will not be accepted upon delivery.

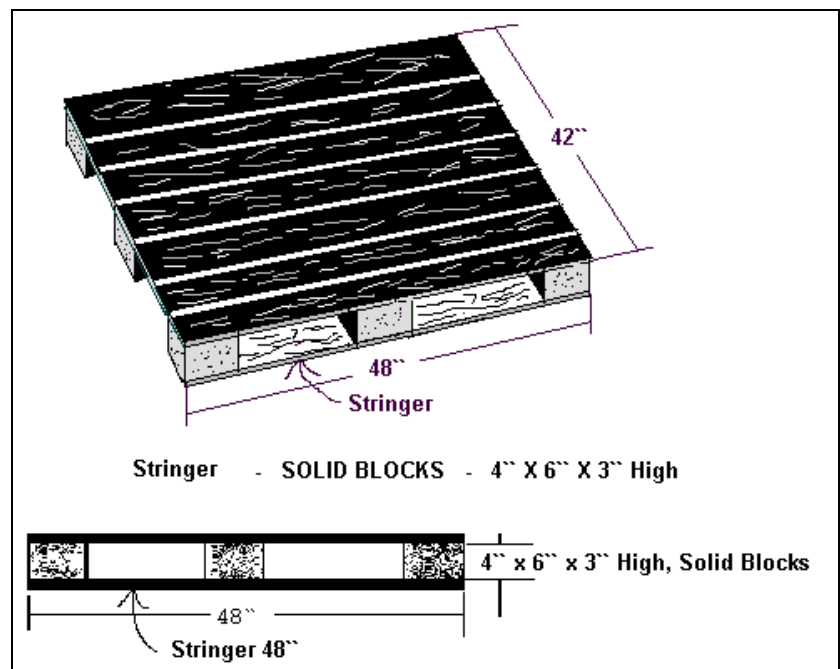

**HOURS OF OPERATION :** 8 a.m. to 12:00 noon / 1:00 p.m. to 4:00 p.m.  
**(Ottawa time)**

**DESTINATION:** Elections Canada Distribution Centre  
100-440 Coventry Road, Ottawa, Ontario K1K 2Y5

**INVOICING:**

Please send your invoice to the following address:

Jocelyn Leroux  
Material Management, OFG  
Elections Canada  
30 Victoria Street  
Gatineau, Quebec K1A 0M6

Or by e-mail:

[gestiondumatérielSGF-materialmanagementSMS@elections.ca](mailto:gestiondumatérielSGF-materialmanagementSMS@elections.ca)

It is the responsibility of the supplier to provide a valid tax registration number for: HST/GST and QST, as applicable. Elections Canada will not validate tax registration numbers. If applicable sales taxes are invoiced without a tax registration number(s), Elections Canada will not pay the applicable sales tax(es).

**Invoices must indicate the Contract number, if applicable, the Reference Number, the revision date and show any correction cost breakdown as applicable.**

**ADDITIONAL INFORMATION:**

**No change in these specifications will be accepted unless approved by the project authority.**

Elections Canada must be informed of the cost of any author's alterations as soon as possible. A contract amendment must be made as soon as any changes affecting cost occur.

The printer is to return to Elections Canada a final electronic file properly identified with all or any corrections made at the proofing stage before invoices are approved for payment.

Wrapping and shipping instructions must be followed to the letter or the Distribution Centre may refuse to accept the shipment.



<b>DESCRIPTION OF DELIVERABLE:</b>	Plastic security bag with grey opaque inside and light green colour on the exterior
<b>REFERENCE NUMBER:</b>	<b>EC 50480 (05/2018)</b>
<b>TITLE:</b>	Advance Poll Bag -light green
<b>QUANTITY:</b>	12,000
<b>OVER:</b>	<b><i>No over / No under</i></b> Elections Canada will not pay an invoice for items received in excess of the quantity stipulated in this specification, nor will it pay the full amount when items are sent in lower quantities than requested. It is the supplier's responsibility to ensure that items are shipped in the correct quantities.
<b>SIZE:</b>	<ul style="list-style-type: none"><li>• Metric: 46 cm long plus 7 cm flap. Total length with flap 53 cm x 37 cm wide open end (plus 10.2cm gusset)</li><li>• Imperial: 18" long plus 2 ¾" flap. Total length with flap 20 ¾" x 14 ½" wide – open end. (plus 4" gusset)</li></ul>
<b>STYLE:</b>	<ul style="list-style-type: none"><li>• <b>Gusset:</b> 10.2 cm (4") at the bottom</li><li>• <b>Air Holes:</b> Plastic bag must have 2 half-moon air holes at the bottom, one on the left side and one on the right side</li></ul>
<b>FLAP:</b>	The 7 cm (2 ¾") flap must have one strip 2 cm wide x 37 cm long (¾" wide x 14 ½" long) of a D transfer tape applied at 1 cm (3/8") from the top of the flap.
<b>PRINTING:</b>	Prints two colours PMS 2253C Light Green for bag – bleeds all sides Text: Black one side no bleed – front only. <b>The square on the front of the flap indicating the placement of the Official Seal must remain white.</b> Print quality – Informational
<b>INK:</b>	PMS 2253C Light green for entire outside body of bag – bleeds all sides. Black for text <b>The square on the front of the flap must remain white</b>

**STOCK:** High density polyethylene 5mil plastic – Co-extruded white outside, grey opaque inside

**COMPONANT:** **Camera Ready file supplied is prepared flat lengthwise including the gusset and flap. The supplier is not required to do additional set up with the PDF, nor any typesetting.**

**IMAGE:**

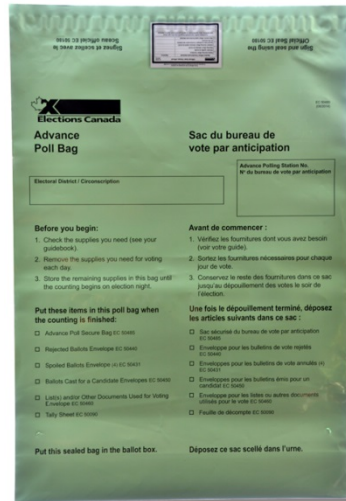

**NOTE: IMAGE FOR INFORMATION PURPOSE ONLY**

**PROOF:** One proof is required for approval before production. Please send to Elections Canada, Material Management, OFG, 30 Victoria Street, Gatineau QC. K1A 0M6. Attention: Diane Lemay.

**PACKAGING:** Package flat 100 per corrugated box. Each box not to weigh more than 35 lbs. Clearly identify each box as to content in a minimum 20 pt. type size.

**Label on Boxes:**

**EC 50480 (05/2018)**  
*Advance Poll Bag – Light Green/  
SAC du bureau de vote par anticipation – vert pâle  
Qty/Qté 100*

**NOTE :** Labeling of items going to the Distribution Centre must be exactly as indicated. If not, they will not be accepted.

**QUOTE SUBMISSION:** Your quotation must show cost per unit and must include the cost of:  
- printing plates (if applicable);

- skids; and
- transportation fee.

**MANDATORY DELIVERY DATE:**

**On or before November 28<sup>th</sup>, 2018**

**Upon approval by the contracting or technical authority partial deliveries will be accepted but entire quantity must be delivered by November 28<sup>th</sup>, 2018**

**SHIPPING INSTRUCTIONS:**

Ship on non-returnable shipping skids 48" wide by 42" deep not to exceed 54" high stacking height. The material must be accessible by hand held hydraulic pallet movers.

**SKIDS:**

Brewery type skid – 4 way entry type, 48" wide by 42" deep, 3 stringers with three blocks, each running 48" long

**NOTE:** Items shipped to the Distribution Centre not on requested skids will not be accepted upon delivery.

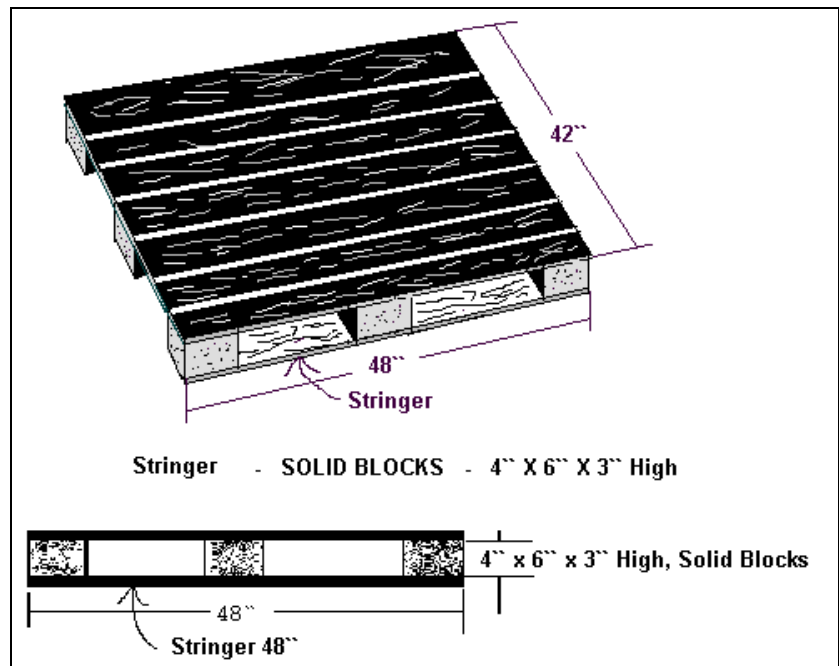

**HOURS OF OPERATION :**  
**(Ottawa time)**

8 a.m. to 12:00 noon / 1:00 p.m. to 4:00 p.m.

**DESTINATION:**

Elections Canada Distribution Centre

100-440 Coventry Road, Ottawa, Ontario K1K 2Y5

**INVOICING:**

Please send your invoice to the following address:

Jocelyne Leroux  
Material management - OFG  
Elections Canada  
30 Victoria Street,  
Gatineau, Quebec K1A 0M6

Or by e-mail:

[gestiondumatérielSGF-materialmanagementSMS@elections.ca](mailto:gestiondumatérielSGF-materialmanagementSMS@elections.ca)

It is the responsibility of the supplier to provide a valid tax registration number for: HST/GST and QST, as applicable. Elections Canada will not validate tax registration numbers. If applicable sales taxes are invoiced without a tax registration number(s), Elections Canada will not pay the applicable sales tax(es).

**Invoices must indicate the Contract number, if applicable, the Reference Number, the revision date and show any correction cost breakdown as applicable**

**ADDITIONAL INFORMATION:**

**No change in these specifications will be accepted unless approved by the project authority.**

Elections Canada must be informed of the cost of any author's alterations as soon as possible. A contract amendment must be made as soon as any changes affecting cost occur.

The printer is to return to Elections Canada a final electronic file properly identified with all or any corrections made at the proofing stage before invoices are approved for payment.

Wrapping and shipping instructions must be followed to the letter or the Distribution Centre may refuse to accept the shipment.

<b>DESCRIPTION OF DELIVERABLE:</b>	Clear Plastic Bag.
<b>REFERENCE NUMBER:</b>	<b>EC 50517 (05/2018)</b>
<b>TITLE:</b>	Ordinary Poll Site Bag
<b>QUANTITY:</b>	28,000
<b>OVER:</b>	<b><i>No over / No under</i></b> Elections Canada will not pay an invoice for items received in excess of the quantity stipulated in this specification, nor will it pay the full amount when items are sent in lower quantities than requested. It is the supplier's responsibility to ensure that items are shipped in the correct quantities.
<b>SIZE:</b>	<ul style="list-style-type: none"><li>• Metric: 46 cm long plus 7 cm flap. Total length with flap 53 cm x 37 cm wide open end plus a 10.2 cm gusset)</li><li>• Imperial: 18" long plus 2 ¾" flap. Total length with flap 20 ¾" x 14 ½" wide – open end. (plus 4" gusset)</li><li>•</li></ul>
<b>STYLE:</b>	<ul style="list-style-type: none"><li>• <b>Gusset:</b> 10.2 cm or 4" gusset at the bottom</li><li>• <b>Air Holes:</b> Plastic bag must have 2 half- moon holes at the bottom, one on the left side and one on the right side</li><li>•</li></ul>
<b>FLAP:</b>	The 7 cm (2 ¾") flap has one strip 2 cm wide x 37 cm long (¾" wide x 14 ½" long) of a D transfer tape applied at 1cm (3/8") from the top of the flap.
<b>PRINTING:</b>	Text: Black one side no bleed – front only. <b>The square on the front of the flap indicating the placement of the Official Seal must be printed in white ink.</b> Print quality – Informational
<b>INK:</b>	Black for text. <b>White for the square on the front of the flap indicating the placement of the Official Seal</b>
<b>STOCK:</b>	High density polyethylene 5mil clear plastic

**COMPONANT:** Camera Ready file supplied is prepared flat lengthwise including the gusset and flap. The supplier is not required to do additional set up with the PDF, nor any typesetting.

**PROOF:** One proof is required for approval before production. Please send to:

Elections Canada,  
Material Management, OFG  
30 Victoria Street,  
Gatineau QC K1A 0M6  
Attention: Diane Lemay

**PACKAGING:** Ship flat 100 per corrugated box. Each box not to weigh more than 35 lbs. Clearly identify each box as to content in a minimum 20 pt. type size.

**Label on Boxes:**

<p><b><i>EC 50517 (05/2018)</i></b> <i>Ordinary Poll Site Bag /</i> <i>Sac du lieu de scrutin ordinaire</i> <i>Qty/Qté 100</i></p>
--

**NOTE :** Labeling of items going to the Distribution Centre must be exactly as indicated. If not, they will not be accepted.

**QUOTE SUBMISSION:** Your quotation must show cost per unit and must include the cost of:

- printing plates (if applicable);
- skids; and
- transportation fee.

**MANDATORY DELIVERY DATE:** **On or before November 28<sup>th</sup>, 2018.**

**Upon approval by the contracting or technical authority partial deliveries will be accepted but entire quantity must be delivered by November 28<sup>th</sup>, 2018.**

**SHIPPING INSTRUCTIONS:** Ship on non-returnable shipping skids 48" wide by 42" deep not to exceed 54" high stacking height. The material must be accessible by hand held hydraulic pallet movers.

**SKIDS:**

Brewery type skid – 4 way entry type, 48" wide by 42" deep, 3 stringers with three blocks, each running 48" long

**NOTE:** Items shipped to the Distribution Centre not on requested skids will not be accepted upon delivery.

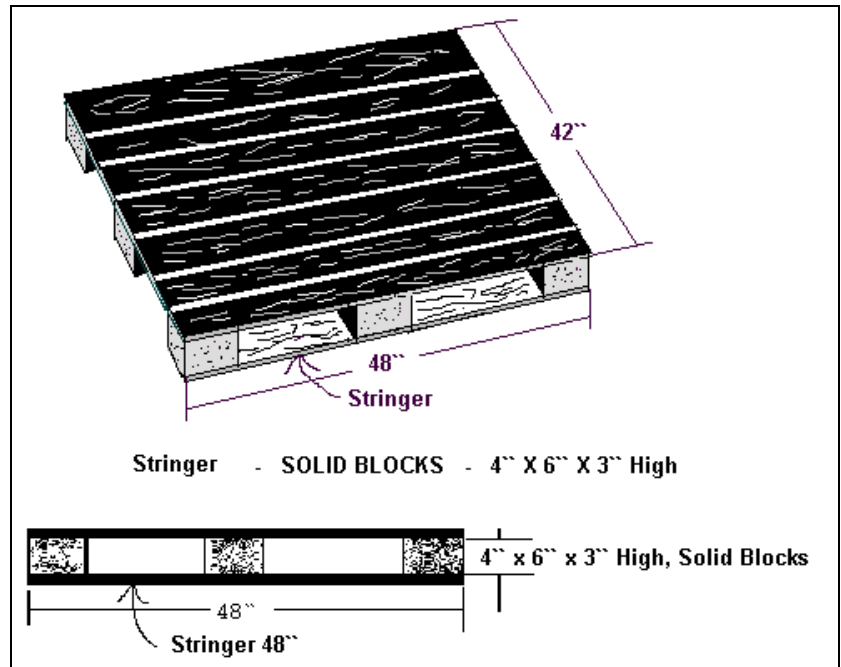

**HOURS OF OPERATION:**  
(Ottawa time)

8 a.m. to 12:00 noon / 1:00 p.m. to 4:00 p.m.

**DESTINATION:**

Elections Canada Distribution Centre  
100-440 Coventry Road, Ottawa, Ontario K1K 2Y5

**INVOICING:**

Please send your invoice to the following address:

Jocelyne Leroux  
Material Management, OFG  
Elections Canada  
30 Victoria Street,  
Gatineau, Quebec K1A 0M6

Or by e-mail:

[gestiondumatérielSGF-materialmanagementSMS@elections.ca](mailto:gestiondumatérielSGF-materialmanagementSMS@elections.ca)

It is the responsibility of the supplier to provide a valid tax registration number for: HST/GST and QST, as applicable. Elections Canada will not validate tax registration numbers. If applicable sales taxes are invoiced without a tax registration number(s), Elections Canada will not pay the applicable sales tax(es).

**Invoices must indicate the Contract number, if applicable, the Reference Number, the revision date and show any correction cost breakdown as applicable**

**ADDITIONAL INFORMATION:**

**No change in these specifications will be accepted unless approved by the project authority.**

Elections Canada must be informed of the cost of any author's alterations as soon as possible. A contract amendment must be made as soon as any changes affecting cost occur.

The printer is to return to Elections Canada a final electronic file properly identified with all or any corrections made at the proofing stage before invoices are approved for payment.

Wrapping and shipping instructions must be followed to the letter or the Distribution Centre may refuse to accept the shipment.



<b>DESCRIPTION OF DELIVERABLE:</b>	Clear Plastic Bag.
<b>REFERENCE NUMBER:</b>	<b>EC 50516 (05/2018)</b>
<b>TITLE:</b>	Advance Poll Site Bag
<b>QUANTITY:</b>	12,000
<b>OVER:</b>	<b><i>No over / No under</i></b> Elections Canada will not pay an invoice for items received in excess of the quantity stipulated in this specification, nor will it pay the full amount when items are sent in lower quantities than requested. It is the supplier's responsibility to ensure that items are shipped in the correct quantities.
<b>SIZE:</b>	<ul style="list-style-type: none"><li>• Metric: 46 cm long plus 7 cm flap. Total length with flap 53 cm x 37 cm wide open end (plus 10.2 cm gusset)</li><li>• Imperial: 18" long plus 2 ¾" flap. Total length with flap 20 ¾" x 14 ½" wide – open end. (plus 4" gusset)</li></ul>
<b>STYLE:</b>	<ul style="list-style-type: none"><li>• <b>Gusset:</b> 10.2 cm or 4" gusset at the bottom</li><li>• <b>Air Holes:</b> Plastic bag must have 2 half- moon holes at the bottom, one on the left side and one on the right side</li></ul>
<b>FLAP:</b>	The 7 cm (2 ¾") flap has one strip 2 cm wide x 37 cm long (¾" wide x 14 ½" long) of a D transfer tape applied at 1cm (3/8") from the top of the flap.
<b>PRINTING:</b>	Text: Black one side no bleed – front only. <b>The square on the front of the flap indicating the placement of the Official Seal must be printed in white ink.</b> Print quality – Informational
<b>INK:</b>	Black for text. <b>White for the square on the front of the flap indicating the placement of the Official Seal.</b>
<b>STOCK:</b>	High density polyethylene 5mil clear plastic

**COMPONANT:** Camera Ready file supplied is prepared flat lengthwise including the gusset and flap. The supplier is not required to do additional set up with the PDF, nor any typesetting.

**PROOF:** One proof is required for approval before production. Please send to:

Elections Canada,  
Material Management, OFG  
30 Victoria Street,  
Gatineau QC K1A 0M6  
Attention: Diane Lemay

**PACKAGING:** Ship flat 100 per corrugated box. Each box not to weigh more than 35 lbs. Clearly identify each box as to content in a minimum 20 pt. type size.

**Label on Boxes:**

<p><b><i>EC 50516 (05/2018)</i></b> <i>Advance Poll Site Bag /</i> <i>Sac du lieu de vote par anticipation</i> <i>Qty/Qté 100</i></p>
---

**NOTE :** Labeling of items going to the Distribution Centre must be exactly as indicated. If not, they will not be accepted.

**QUOTE SUBMISSION:** Your quotation must show cost per unit and must include the cost of:

- printing plates (if applicable);
- skids; and
- transportation fee.

**MANDATORY DELIVERY DATE:** **On or before November 28<sup>th</sup>, 2018.**  
**Upon approval by the contracting or technical authority partial deliveries will be accepted but entire quantity must be delivered by November 28<sup>th</sup>, 2018.**

**SHIPPING INSTRUCTIONS:** Ship on non-returnable shipping skids 48" wide by 42" deep not to exceed 54" high stacking height. The material must be accessible by hand held hydraulic pallet movers.

**SKIDS:**

Brewery type skid – 4 way entry type, 48" wide by 42" deep, 3 stringers with three blocks, each running 48" long

**NOTE:** Items shipped to the Distribution Centre not on requested skids will not be accepted upon delivery.

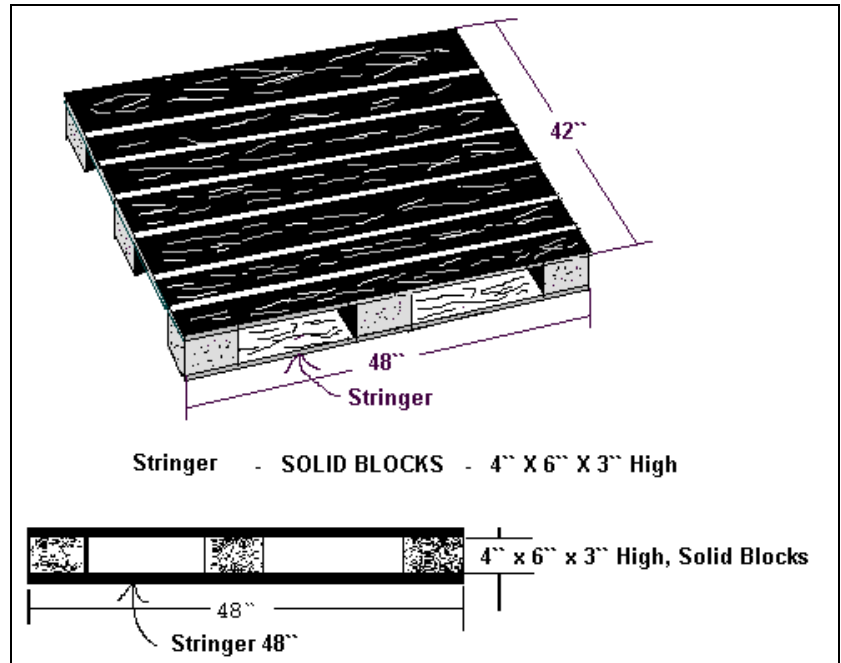

**HOURS OF OPERATION:**  
(Ottawa time)

8 a.m. to 12:00 noon / 1:00 p.m. to 4:00 p.m.

**DESTINATION:**

Elections Canada Distribution Centre  
100-440 Coventry Road, Ottawa, Ontario K1K 2Y5

**INVOICING:**

Please send your invoice to the following address:

Jocelyne Leroux  
Material Management, OFG  
Elections Canada  
30 Victoria Street,  
Gatineau, Quebec K1A 0M6

Or by e-mail:

[gestiondumatérielSGF-materialmanagementSMS@elections.ca](mailto:gestiondumatérielSGF-materialmanagementSMS@elections.ca)

It is the responsibility of the supplier to provide a valid tax registration number for: HST/GST and QST, as applicable. Elections Canada will not validate tax registration numbers. If applicable sales taxes are invoiced without a tax registration number(s), Elections Canada will not pay the applicable sales tax(es).

**Invoices must indicate the Contract number, if applicable, the Reference Number, the revision date and show any correction cost breakdown as applicable**

**ADDITIONAL INFORMATION:**

**No change in these specifications will be accepted unless approved by the project authority.**

Elections Canada must be informed of the cost of any author's alterations as soon as possible. A contract amendment must be made as soon as any changes affecting cost occur.

The printer is to return to Elections Canada a final electronic file properly identified with all or any corrections made at the proofing stage before invoices are approved for payment.

Wrapping and shipping instructions must be followed to the letter or the Distribution Centre may refuse to accept the shipment.