

INVITATION TO TENDER

RETURN BIDS TO:

Bid Receiving / Agriculture and Agri-Food Canada

Agriculture and Agri-Food Canada
 Central Experimental Farm (CEF)
 Bid Receiving (Main Entrance)
 K. W. Neatby building
 960 Carling Avenue
 Ottawa, Ontario K1A 0C6

TENDER TO:

Agriculture and Agri-Food Canada

We hereby offer to sell to Her Majesty the Queen in right of Canada, in accordance with the terms and conditions set out herein, referred to herein or attached hereto, the construction listed herein and on any attached sheets at the price(s) set out therefor.

Comments

ISSUING OFFICE

Agriculture and Agri-Food Canada
 Integrated Services
 960 Carling Ave.
 Ottawa, ON
 K1A 0C6

Title		
Building 82 Restoration		
Solicitation No.		Date
18-1163		2018-09-12
Client Reference No.		
CEF18 00174		
File No.		
18-1163		
Solicitation Closes:		
Wednesday, September 26, 2018, at 02:00 PM, Local Standard Time.		
F.O.B		
<input type="radio"/> Plant <input checked="" type="radio"/> Destination <input type="radio"/> Other		
Address Enquiries to:		
Daniel Lafreniere		
Title:		
Senior Contracts Officer		
Email:		
daniel.lafreniere@canada.ca		
Telephone Number	Ext.	Fax Number
613 759-6876		613 759-7005
Destination		
Agriculture and Agri-Food Canada Central Experimental Farm (CEF) 960 Carling Ave. Ottawa, ON K1A 0C6		

Instructions: See Herein

Delivery Required	Delivery Offered	
Vendor / Firm Name and Address		
Telephone Number	Ext.	Fax Number
Name and title of person authorized to sign on behalf of Vendor / Firm (type or print)		
Signature		Date
_____		_____

TABLE OF CONTENTS

SPECIAL INSTRUCTIONS TO BIDDERS (SI)

INSTRUCTIONS TO BIDDERS (IB)

CONTRACT DOCUMENTS (CD)

GENERAL CONDITIONS FOR MINOR WORKS (GC)

INSURANCE TERMS (IT)

BID AND ACCEPTANCE FORM

DRAWINGS and SPECIFICATIONS



SPECIAL INSTRUCTIONS TO BIDDERS

- SI01 Bid Documents
- SI02 Enquiries during the Solicitation Period
- SI03 Non-Mandatory Site Visit
- SI04 Revision of Bid
- SI05 Bid Results
- SI06 Bid Validity Period
- SI07 Construction Documents
- SI08 Personnel Security Requirements
- SI09 Integrity Provisions - Declaration of Convicted Offences

SI01 BID DOCUMENTS

1) The following are the bid documents:

- (a) SPECIAL INSTRUCTIONS TO BIDDERS;
- (b) INSTRUCTIONS TO BIDDERS - Form A5319-E; and,
- (c) BID AND ACCEPTANCE FORM - Form A5312-E and any attachments thereto.

Canada reserves the right to revise or amend the Bid Documents prior to the date set for opening bids. Such revisions or amendments, if any, will be announced by an addendum or addenda to the documents.

Submission of a bid constitutes acknowledgement that the Bidder has read and agrees to be bound by these documents.

SI02 ENQUIRIES DURING THE SOLICITATION PERIOD

1) Enquiries regarding this bid must be submitted in writing to the Contracting Officer. The Contracting Officer for the purpose of this bid is:

Dani el Lafreni ère
A/Seni or Contracts Offi cer

- 2) Except for the approval of alternative materials as described in IB14 of the INSTRUCTIONS TO BIDDERS, enquiries should be received no later than five (5) calendar days prior to the date set for solicitation closing to allow sufficient time to provide a response. Enquiries received after that time may not result in an answer being provided.
- 3) To ensure consistency and quality of the information provided to Bidders, the Contracting Officer shall examine the content of the enquiry and shall decide whether or not to issue an amendment.
- 4) All enquiries and other communications related to this bid sent throughout the solicitation period are to be directed ONLY to the Contracting Officer. Non-compliance with this requirement during the solicitation period can, for that reason alone, result in disqualification of a bid.

SPECIAL INSTRUCTIONS TO BIDDERS (Continued)

SI03 NON-MANDATORY SITE VISIT

- 1) Before submitting their bid, the Contractor shall examine the jobsite, construction and storage areas, compare drawings and specifications with existing conditions, and fully satisfy themselves as to all data and matters required for the completion of the contract.
- 2) There will be a site visit on Tuesday, September, 18, 2018 at 10: 00 AM PM Local Standard Time.

Interested bidders are to meet at:

K. W. Neatby Building (20) - Main Lobby
960 Carling Ave. Ottawa, ON K1A 0C6

SI04 REVISION OF BID

- 1) A bid may be revised by letter or facsimile in accordance with IB10 of the INSTRUCTIONS TO BIDDERS. The facsimile number for receipt of revisions is: 623 759-7005 .

SI05 BID RESULTS

- 1) Following bid closing, bid results may be obtained from the bid receiving office by email at dani.e.lafreniere@canada.ca .

SI06 BID VALIDITY PERIOD

- 1) Canada reserves the right to seek an extension to the bid validity period prescribed in Clause 4 of the BID AND ACCEPTANCE FORM. Upon notification in writing from Canada, Bidders shall have the option to either accept or reject the proposed extension.

SI07 CONSTRUCTION DOCUMENTS

- 1) The successful contractor will be provided with one paper copy of the sealed and signed drawings, the specifications and the amendments upon acceptance of the offer. Additional copies, up to a maximum of one (1), will be provided free of charge upon request by the Contractor. Obtaining more copies shall be the responsibility of the Contractor including costs.

SI08 PERSONNEL SECURITY REQUIREMENTS

- 1) The successful Bidder's personnel, as well as any subcontractor and its personnel, who are required to perform any part of the work pursuant to the subsequent contract, must meet the following contract security requirements:
 - Unscreened personnel may be used for the work. Unscreened personnel will not need an escort.

SPECIAL INSTRUCTIONS TO BIDDERS (Continued)

SI09 INTEGRITY PROVISIONS – DECLARATION OF CONVICTED OFFENCES

As applicable, pursuant to IB18 of the Declaration of Convicted Offences, paragraph 10 (copied below) of the General Instruction AAFC / AAC5319, the Bidder must provide with its bid, a completed *Declaration Form*, to be given further consideration in the procurement process.

Declaration of Convicted Offences

Where a Bidder or its Affiliate is unable to certify that it has not been convicted of any of the offences referenced under the Canadian Offences Resulting in Legal Incapacity, the Canadian Offences and the Foreign Offences subsections, the Bidder must provide with its bid the completed [Declaration Form](#), to be given further consideration in the procurement process.

INSTRUCTIONS TO BIDDERS

IB01	Completion of Bid
IB02	Identity or Legal Capacity of the Bidder
IB03	Applicable Taxes
IB04	Tax to Be Included
IB05	Capital Development and Redevelopment Charges
IB06	Registry and Pre-qualification of Floating Plant
IB07	Listing of Subcontractors and Suppliers
IB08	Bid Security Requirements
IB09	Submission of Bid
IB10	Revision of Bid
IB11	Acceptance of Bid
IB12	Bid Costs
IB13	Compliance with Applicable Laws
IB14	Approval of Alternative Materials
IB15	Income Tax Requirement
IB16	Contingency Fees
IB17	Status of the Bidder
IB18	Integrity Provisions - Bids Over \$10,000.00
IB19	Code of Conduct for Procurement - Bid

IB01 Completion of Bid

- 1) The bid shall be:
 - (a) submitted on the BID AND ACCEPTANCE FORM provided by AAFC or on a clear and legible reproduced copy of such BID AND ACCEPTANCE FORM that must be identical in content and format to the BID AND ACCEPTANCE FORM provided by AAFC;
 - (b) based on the Bid Documents listed in the SPECIAL INSTRUCTIONS TO BIDDERS;
 - (c) correctly completed in all respects;
 - (d) signed, with an original signature, by a duly authorized representative of the Bidder; and
 - (e) accompanied by any other document or documents specified elsewhere in the solicitation where it is stipulated that said documents are to accompany the bid.

- 2) Subject to paragraph 6) of IB11, any alteration to the pre-printed or pre-typed sections of the BID AND ACCEPTANCE FORM, or any condition or qualification placed upon the bid shall be cause for disqualification. Alterations, corrections, changes or erasures made to statements or figures entered on the BID AND ACCEPTANCE FORM by the Bidder shall be initialed by the person or persons signing the bid. Initials shall be original(s). Alterations, corrections, changes or erasures that are not initialed shall be deemed void and without effect.

- 3) Unless otherwise noted elsewhere in the Bid Documents, facsimile copies of bids are not acceptable.

INSTRUCTIONS TO BIDDERS (Continued)

IB02 Identity or Legal Capacity of the Bidder

- 1) In order to confirm the authority of the person or persons signing the bid or to establish the legal capacity under which the Bidder proposes to enter into Contract, any Bidder who carries on business in other than its own personal name shall, if requested by Canada, provide satisfactory proof of:
 - (a) such signing authority; and
 - (b) the legal capacity under which it carries on business;prior to contract award. Proof of signing authority may be in the form of a certified copy of a resolution naming the signatory(ies) that is (are) authorized to sign this bid on behalf of the corporation or partnership. Proof of legal capacity may be in the form of a copy of the articles of incorporation or the registration of the business name of a sole proprietor or partnership.

IB03 Applicable Taxes

- 1) Bidders are not to include any amounts for Applicable Taxes (Goods and Services Tax (GST), Harmonized Sales Tax (HST) or Quebec Sales Tax (QST), whichever is applicable. Any amount levied in respect of Applicable Taxes shall be billed as a separate item in a progress claim submitted by the Contractor, and shall be paid to the Contractor in addition to the amount approved by Canada for work performed under the Contract. The Contractor shall be required to remit the appropriate amount to the appropriate tax authority in accordance with the applicable legislation.

IB04 Tax to Be Included

- 1) The Contractor is not entitled to use Canada's exemptions from any tax, such as provincial sales taxes, unless otherwise specified by law. The Contractor must pay applicable provincial sales tax, ancillary taxes, and any commodity tax, on taxable goods or services used or consumed in the performance of the Contract (in accordance with applicable legislation), including for material incorporated into real property.

IB05 Capital Development and Redevelopment Charges

- 1) For the purposes of GC1.5 in the General Conditions of the Contract, only fees or charges directly related to the processing and issuing of building permits shall be included. The Bidder shall not include any monies in the bid amount for special municipal development, redevelopment or other fees or charges which a municipal authority may seek as a prerequisite to the issuance of building permits.

IB06 Registry and Pre-qualification of Floating Plant

- 1) Dredges or other floating plant to be used in the performance of the Work must be of Canadian registry. For dredges or other floating plant that are not of Canadian make or manufacture, the Bidder must obtain a certificate of qualification from Industry Canada and this certificate must accompany the bid. Plant so qualified by Industry Canada may be accepted on this project.

IB07 Listing of Subcontractors and Suppliers

- 1) Notwithstanding any list of Subcontractors that the Bidder may be required to submit as part of the bid, the Bidder submitting the lowest acceptable bid shall, within 48 hours of receipt of a notice to do so, submit all information requested in the said notice including the names of Subcontractors and Suppliers for the part or parts of the Work listed. Failure to do so may result in the disqualification of its bid.

INSTRUCTIONS TO BIDDERS (Continued)

IB08 Bid Security Requirements

- 1) **NO** bid security is required for this solicitation notice.

IB09 Submission of Bid

- 1) The BID AND ACCEPTANCE FORM, duly completed, shall be enclosed and sealed in an envelope provided by the Bidder, and shall be addressed and submitted to the office designated on the Front Page of the BID AND ACCEPTANCE FORM for the receipt of bids. The bid must be received on or before the date and time set for solicitation closing.
- 2) Unless otherwise specified in the SPECIAL INSTRUCTIONS TO BIDDERS
 - (a) the bid shall be in Canadian currency;
 - (b) exchange rate fluctuation protection is not offered; and
 - (c) any request for exchange rate fluctuation protection shall not be considered.
- 3) Prior to submitting the bid, the Bidder shall ensure that the following information is clearly printed or typed on the face of the bid envelope:
 - (a) Solicitation/File Number;
 - (b) Name of Bidder;
 - (c) Return address; and
 - (d) Closing Date and Time.
- 4) Subject to paragraph 6) of IB11, failure to comply with paragraphs 1), 2) and 3) of IB09 shall render the bid liable to disqualification. Timely and correct delivery of bids is the sole responsibility of the Bidder.

IB10 Revision of Bid

- 1) A bid submitted in accordance with these instructions may be revised by letter or facsimile provided the revision is received at the office designated for the receipt of bids, on or before the date and time set for the closing of the bid. The letter or facsimile shall:
 - (a) be on the Bidder's letterhead or bear a signature that identifies the Bidder;
 - (b) for the lump sum portion of a bid, clearly identify the amount of the current revision. The total aggregate sum of all revisions submitted, including the current revision, shall be shown separately; and
 - (c) for the Price Per Unit portion of a bid, clearly identify the change(s) in the Price(s) per Unit and the specific Item(s) to which each change applies. If a revision is to be applied to a specific Item that was previously amended then, in addition to the amount of the current revision, the total aggregate sum of all revisions submitted, including the current revision, for that Item shall be shown separately.
- 2) A letter or facsimile submitted to confirm an earlier revision shall be clearly identified as "CONFIRMATION ONLY" for each contemplated change.
- 3) Failure to comply with any of the above provisions shall result in the rejection of the non-compliant revision(s) only. The bid shall be evaluated based on the original bid submitted and all other compliant revision(s).

IB11 Acceptance of Bid

- 1) Canada may accept any bid, whether it is the lowest or not, or may reject any or all bids.
- 2) Without limiting the generality of paragraph 1) of IB11, Canada may reject a bid if any of the following circumstances is present:

INSTRUCTIONS TO BIDDERS (Continued)

- (a) the Bidder, or any employee or subcontractor included as part of the bid, has been convicted under section 121 ("Frauds on the government" & "Contractor subscribing to election fund"), 124 ("Selling or purchasing office"), 380 ("Fraud committed against Her Majesty") or 418 ("Selling defective stores to Her Majesty") of the Criminal Code of Canada; or under paragraph 80(1)(d) ("False entry, certificate of return"), subsection 80(2) ("Fraud against Her Majesty") or Section 154.01 ("Fraud against Her Majesty") of the *Financial Administration Act*;
 - (b) the Bidder's bidding privileges are suspended or are in the process of being suspended;
 - (c) the bidding privileges of any employee or subcontractor included as part of the bid are suspended or are in the process of being suspended, which suspension or pending suspension would render that employee or subcontractor ineligible to bid on the Work, or the portion of the Work the employee or subcontractor is to perform;
 - (d) with respect to current or prior transactions with Canada
 - (i) the Bidder is bankrupt or if, for whatever reason, its activities are rendered inoperable for an extended period;
 - (ii) evidence, satisfactory to Canada, of fraud, bribery, fraudulent misrepresentation or failure to comply with any law protecting individuals against any manner of discrimination, has been received with respect to the Bidder, any of its employees or any subcontractor included as part of its bid;
 - (iii) Canada has exercised, or intends to exercise, the contractual remedy of taking the work out of the contractor's hands with respect to a contract with the Bidder, any of its employees or any subcontractor included as part of its bid; or
 - (iv) Canada determines that the Bidder's performance on other contracts is sufficiently poor to jeopardize the successful completion of the requirement being bid on.
- 3) In assessing the Bidder's performance on other contracts pursuant to subparagraph 2)(d)(iv) of IB11, Canada may consider, but not be limited to, such matters as:
- (a) the quality of workmanship in performing the Work;
 - (b) the timeliness of completion of the Work;
 - (c) the overall management of the Work and its effect on the level of effort demanded of the department and its representative; and
 - (d) the completeness and effectiveness of the Contractor's safety program during the performance of the Work.
- 4) Without limiting the generality of paragraphs 1), 2) and 3) of IB11, Canada may reject any bid based on an unfavourable assessment of the:
- (a) adequacy of the bid price to permit the work to be carried out and, in the case of a bid providing prices per unit or a combination of lump sum and prices per unit, whether each such price reasonably reflects the cost of performing the part of the work to which that price applies;
 - (b) Bidder's ability to provide the necessary management structure, skilled personnel, experience and equipment to perform competently the work under the Contract; and
 - (c) Bidder's performance on other contracts.
- 5) If Canada intends to reject a bid pursuant to a provision of paragraphs 1), 2), 3) or 4) of IB11, other than subparagraph 2)(b) of IB11, Canada shall so inform the Bidder and provide the Bidder ten (10) days within which to make representations, prior to making a final decision on the bid rejection.
- 6) Canada may waive informalities and minor irregularities in bids received if Canada determines that the variation of the bid from the exact requirements set out in the Bid Documents can be corrected or waived without being prejudicial to other Bidders.

INSTRUCTIONS TO BIDDERS (Continued)

IB12 Bid Costs

- 1) No payment will be made for costs incurred in the preparation and submission of a bid in response to the bid solicitation. Costs associated with preparing and submitting a bid, as well as any costs incurred by the Bidder associated with the evaluation of the bid, are the sole responsibility of the Bidder.

IB13 Compliance with Applicable Laws

- 1) By submission of a bid, the Bidder certifies that the Bidder has the legal capacity to enter into a contract and is in possession of all valid licences, permits, registrations, certificates, declarations, filings, or other authorizations necessary to comply with all federal, provincial and municipal laws and regulations applicable to the submission of the bid and entry into any ensuing contract for the performance of the work.
- 2) For the purpose of validating the certification in paragraph 1) of IB13, a Bidder shall, if requested, provide a copy of every valid licence, permit, registration, certificate, declaration, filing or other authorization listed in the request, and shall provide such documentation within the time limit(s) set out in the said request.
- 3) Failure to comply with the requirements of paragraph 2) of IB13 shall result in disqualification of the bid.

IB14 Approval of Alternative Materials

- 1) When materials are specified by trade names or trademarks, or by manufacturers' or suppliers' names, the bid shall be based on use of the named materials. During the bid period, alternative materials may be considered provided full technical data is received in writing by the Contracting Officer at least 10 calendar days prior to the bid closing date.

IB15 Income Tax Requirement

- 1) Payments made under applicable contracts must be reported by Canada for taxation purposes. To comply with this requirement, the successful bidder shall provide to Canada immediately upon award: its legal name; address; and Revenue Canada identifier (SIN, BN, GST/HST, T2N number) as is applicable.

IB16 Contingency Fees

- 1) The Bidder declares that the Bidder has not, directly or indirectly, paid or agreed to pay, and will not, directly or indirectly, pay a contingency fee to any individual for the solicitation, negotiation or obtaining of the contract if the payment of the fee would require the individual to file a return under section 5 of the *Lobbying Act*.

IB17 Status of the Bidder

- 1) The Bidder declares that the Bidder has not been convicted of an offence, other than an offence for which a pardon has been granted, under section 121, 124 or 418 of the *Criminal Code*.

IB18 Integrity Provisions - Bids Over \$10,000.00

INSTRUCTIONS TO BIDDERS (Continued)

- 1) Ineligibility and Suspension Policy (the "Policy"), and all related Directives, are incorporated by reference into, and form a binding part of the procurement process. The Supplier must comply with the Policy and Directives, which can be found at [Ineligibility and Suspension Policy](#).
- 2) Under the Policy, charges and convictions of certain offences against a Supplier, its affiliates or first tier subcontractors, and other circumstances, will or may result in a determination by Public Works and Government Services Canada (PWGSC) that the Supplier is ineligible to enter, or is suspended from entering into a contract with Canada. The list of ineligible and suspended Suppliers is contained in PWGSC's Integrity Database. The Policy describes how enquiries can be made regarding the ineligibility or suspension of Suppliers.
- 3) In addition to all other information required in the procurement process, the Supplier must provide the following:
 - a. by the time stated in the Policy, all information required by the Policy described under the heading "Information to be Provided when Bidding, Contracting or Entering into a Real Property Agreement"; and
 - b. with its bid / quote / proposal, a complete list of all foreign criminal charges and convictions pertaining to itself, its affiliates and its proposed first tier subcontractors that, to the best of its knowledge and belief, may be similar to one of the listed offences in the Policy. The list of foreign criminal charges and convictions must be submitted using an Integrity Declaration Form, which can be found at [Declaration form for procurement](#).
- 4) Subject to subsection 5, by submitting a bid / quote / proposal in response a request by AAFC, the Supplier certifies that:
 - a. it has read and understands the [Ineligibility and Suspension Policy](#);
 - b. it understands that certain domestic and foreign criminal charges and convictions, and other circumstances, as described in the Policy, will or may result in a determination of ineligibility or suspension under the Policy;
 - c. it is aware that Canada may request additional information, certifications, and validations from the Supplier or a third party for purposes of making a determination of ineligibility or suspension;
 - d. it has provided with its bid / quote / proposal a complete list of all foreign criminal charges and convictions pertaining to itself, its affiliates and its proposed first tier subcontractors that, to the best of its knowledge and belief, may be similar to one of the listed offences in the Policy;
 - e. none of the domestic criminal offences, and other circumstances, described in the Policy that will or may result in a determination of ineligibility or suspension, apply to it, its affiliates and its proposed first tier subcontractors; and
 - f. it is not aware of a determination of ineligibility or suspension issued by PWGSC that applies to it.
- 5) Where a Supplier is unable to provide any of the certifications required by subsection 4, it must submit with its bid/ quote / proposal a completed Integrity Declaration Form, which can be found at [Declaration form for procurement](#).
- 6) Canada will declare non-responsive any bid / quote / proposal in respect of which the information requested is incomplete or inaccurate, or in respect of which the information contained in a certification or declaration is found by Canada to be false or misleading in any respect. If Canada

INSTRUCTIONS TO BIDDERS (Continued)

establishes after award of the Contract that the Supplier provided a false or misleading certification or declaration, Canada may terminate the Contract for default. Pursuant to the Policy, Canada may also determine the Supplier to be ineligible for award of a contract for providing a false or misleading certification or declaration.

Ineligibility and Suspension Policy - <http://www.tpsgc-pwgsc.gc.ca/ci-if/politique-policy-eng.html>

Declaration form for procurement - <http://www.tpsgc-pwgsc.gc.ca/ci-if/declaration-eng.html>

IB19 Code of Conduct for Procurement - Bid

- 1) The Code of Conduct for Procurement provides that Bidders must respond to bid solicitations in an honest, fair and comprehensive manner, accurately reflect their capacity to satisfy the requirements set out in the bid solicitation and resulting contract, submit bids and enter into contracts only if they will fulfill all obligations of the Contract. By submitting a bid, the Bidder is certifying that it is complying with the Code of Conduct for Procurement. Failure to comply with the Code of Conduct for Procurement may render the bid non-responsive.

CONTRACT DOCUMENTS (CD)

1. The following are the contract documents:

- a) Contract Page(s) when signed by Canada;
- b) Duly completed Bid and Acceptance Form and any Appendices attached thereto;
- c) Drawings and Specifications;
- d) General Conditions for Minor Works;
- e) Insurance Terms;
- f) Any amendment issued or any allowable bid revision received before the date and time set or solicitation closing;
- g) Any amendment incorporated by mutual agreement between Canada and the Contractor before acceptance of the bid; and
- h) Any amendment or variation of the contract documents that is made in accordance with the General Conditions.

2. The language of the contract documents is the language of the Bid and Acceptance Form submitted.



TABLE OF CONTENTS GENERAL CONDITIONS FOR MINOR WORKS

GC 1	GENERAL PROVISIONS
GC 1.1	Definition
GC 1.2	Contract Documents
GC 1.3	Assignment
GC 1.4	Subcontracting
GC 1.5	Laws, Permits and Taxes
GC 1.6	Former Public Office Holders
GC 1.7	Status of the Contractor
GC 1.8	Contingency Fees
GC 1.9	Disclosure of Basic Information
GC 1.10	Integrity Provisions - Contracts over \$10,000.00
GC 1.11	Code of Conduct for Procurement - Contracts over \$10,000.00
GC 2	ADMINISTRATION OF THE CONTRACT
GC 2.1	Departmental Representative's Rights and Obligations
GC 2.2	Contractor's Superintendent and Workers
GC 2.3	Records to be Kept by the Contractor
GC 2.4	Notices
GC 3	EXECUTION OF THE WORK
GC 3.1	Material, Plant and Real Property Become the Property of Canada
GC 3.2	Cooperation With Other Contractors
GC 3.3	Use of the Work and Cleanup of Site
GC 3.4	Warranty and Rectification of Defects
GC 4	PROTECTION, HEALTH AND SAFETY
GC 4.1	Material, Plant and Real Property Supplied by Canada
GC 4.2	Construction Safety
GC 5	TERMS OF PAYMENT
GC 5.1	Definitions
GC 5.2	Payment - General Provisions
GC 5.3	Progress Payments
GC 5.4	Interest on Overdue Accounts
GC 5.5	Payment in the Event of Termination
GC 5.6	Final Completion
GC 5.7	Determination of Price
GC 5.8	Claims Against and Obligations of the Contractor or Subcontractor
GC 6	CHANGES IN THE WORK
GC 6.1	Changes in the Work
GC 6.2	Changes in Subsurface Conditions and Delays by Canada
GC 6.3	Extension of Time
GC 7	DEFAULT, SUSPENSION OR TERMINATION OF CONTRACT
GC 7.1	Taking the Work Out of the Contractor's Hands
GC 7.2	Effect of Taking the Work Out of the Contractor's Hands
GC 7.3	Suspension of the Contract
GC 7.4	Termination of the Contract
GC 8	DISPUTE RESOLUTION
GC 9	INDEMNIFICATION AND INSURANCE
GC 9.1	Indemnification
GC 9.2	Insurance Contracts
GC 9.3	Insurance Proceeds



GENERAL CONDITIONS FOR MINOR WORKS

GC 1 GENERAL PROVISIONS

GC 1.1 Definition

- "Applicable Taxes" means the Goods and Services Tax (GST), the Harmonized Sales Tax (HST), and any provincial tax, by law, payable by Canada such as, the Quebec Sales Tax (QST) as of April 1, 2013.
- "Canada", "Her Majesty" means Her Majesty, the Queen in right of Canada;
- "Contract" means the contract documents referred to as such therein and every other document specified or referred to in any of them as forming part of the Contract, all as amended by agreement of the parties;
- "Contractor" means a person, with whom Canada enters into a Contract to do the Work;
 - "Departmental Representative" means the person designated in the Contract, or by written notice to the Contractor, to act as the Departmental Representative for the purposes of the Contract, and includes a person, designated and authorized in writing by the Departmental Representative to the Contractor;
- "Material" includes all commodities, articles, machinery, equipment, fixtures and things required to be furnished in accordance with the Contract for incorporation into the Work;
- "Person" includes, unless there is an express stipulation in the Contract to the contrary, any partnership, proprietorship, firm, joint venture, consortium or corporation;
- "Plant" includes all tools, implements, machinery, vehicles, structures, equipment, articles and things that are necessary for the performance of the Contract, other than Material and those tools customarily provided by a trades person in practicing a trade;
- "Work" means everything that is necessary to be done, furnished or delivered by the Contractor to perform the Contract in accordance with the Contract Documents;

GC 1.2 Contract Documents

1. In interpreting the Contract, in the event of discrepancies or conflicts between anything in the Drawings and Specifications or Scope of Work and the General Conditions, the General Conditions govern.
2. In interpreting the Drawings and Specifications, in the event of discrepancies or conflicts between:
 - (a) the Drawings and Specifications, the Specifications govern;
 - (b) the Drawings, the Drawings with the largest scale govern; and
 - (c) figured dimensions and scaled dimensions, the figured dimensions govern.

GC 1.3 Assignment

1. This Contract shall not be assigned without the written consent of Canada.

GC 1.4 Subcontracting

1. The Contractor shall:
 - (a) not subcontract the whole or any part of the Work without the written consent of the Departmental Representative except for subcontracts specified in the Contract; and
 - (b) ensure that all subcontracts entered into at any tier shall incorporate all the terms and conditions of the Contract that can reasonably be applied thereto.

GENERAL CONDITIONS FOR MINOR WORKS (Continued)

GC 1.5 Laws, Permits and Taxes

1. The Contractor shall comply with all legislative and regulatory provisions whether federal, provincial, territorial or municipal applicable to the performance of the Work and shall require compliance therewith by all of its subcontractors and suppliers at any tier as if the Work were being performed for an owner other than Canada.
2. Unless otherwise provided for in the Contract, the Contractor shall obtain all permits and hold all certificates and licenses required for the performance of the Work.
3. Applicable Taxes will be paid by Canada at time when a progress payment is being made. It is the sole responsibility of the Contractor to charge Applicable Taxes at the correct rate in accordance with applicable legislation. The Contractor agrees to remit to appropriate tax authorities any amounts of Applicable Taxes paid or due.
4. The Contractor is not entitled to use Canada's exemptions from any tax, such as provincial sales taxes, unless otherwise specified by law. The Contractor must pay applicable provincial sales tax, ancillary taxes, and any commodity tax, on taxable goods or services used or consumed in the performance of the Contract (in accordance with applicable legislation), including for material incorporated into real property.

GC 1.6 Former Public Office Holders

1. No former public office holder who is not in compliance with the post-employment provisions of the Conflict of Interest and Post-Employment Code for Public Office Holders shall derive a direct benefit from the Contract.

GC 1.7 Status of the Contractor

1. The Contractor is engaged as an independent Contractor for the sole purpose of performing the Work. Neither the Contractor nor any of its personnel is engaged as an employee, servant or agent of Canada. The Contractor is responsible for all deductions and remittances required by law in relation to its employees including those required for Canada or Quebec Pension Plans, employment insurance, workers' compensation, and income tax.
2. The Contractor declares that the Contractor has not been convicted of an offence, other than an offence for which a pardon has been granted, under section 121, 124 or 418 of the Criminal Code.

GC 1.8 Contingency Fees

1. The Contractor declares that the Contractor has not, directly or indirectly, paid or agreed to pay, and will not, directly or indirectly, pay a contingency fee to any individual for the solicitation, negotiation or obtaining of the contract if the payment of the fee would require the individual to file a return under section 5 of the *Lobbying Act*.

GC 1.9 Disclosure of Basic Information

1. The Contractor consents, in the case of a contract that has a value in excess of \$10,000, to the public disclosure of basic information, other than information described in any of paragraphs 20(1)(a) to (d) of the Access to Information Act, relating to the contract.

GENERAL CONDITIONS FOR MINOR WORKS (Continued)

GC 1.10 Integrity Provisions - Contracts over \$10,000.00

- 1) The Ineligibility and Suspension Policy (the "Policy") and all related Directives are incorporated into, and form a binding part of the Contract. The Contractor must comply with the provisions of the Policy and Directives, which can be found on Public Works and Government Services Canada's website at Ineligibility and Suspension Policy. (<http://www.tpsgc-pwgsc.gc.ca/ci-if/politique-policy-eng.html>).

GC 1.11 Code of Conduct for Procurement - Contracts Over \$10,000.00

- 1) The Contractor agrees to comply with the Code of Conduct (<http://www.tpsgc-pwgsc.gc.ca/app-acq/cndt-cndct/contexte-context-eng.html>) for Procurement and to be bound by its terms for the period of the Contract.

GC 2 ADMINISTRATION OF THE CONTRACT

GC 2.1 Departmental Representative's Rights and Obligations

1. The Departmental Representative shall:
 - (a) have access to the Work at all times;
 - (b) decide questions regarding what has been done or what the Contractor is required to do;
 - (c) decide questions regarding the acceptability of the quality or quantity of any Labour, Plant or Material used or consumed in the execution of the Work; and
 - (d) decide questions regarding the timing and scheduling of the Work.

GC 2.2 Contractor's Superintendent and Workers

1. The Contractor shall keep a competent superintendent and capable and skilled workers on the site of the Work at all times during the progress of the Work. If, in the opinion of the Departmental Representative, the superintendent or the workers are deemed to be unacceptable because of incompetence, improper conduct or security risk, they shall be removed from the site of the Work and replaced forthwith.

GC 2.3 Records to be Kept by the Contractor

1. The Contractor shall maintain and keep intact complete records relating to the Work together with all tender calls, quotations, contracts, correspondence, invoices and any payment of fees or other compensation for the solicitation, negotiating or obtaining of the contract until the expiration of two (2) years after the date that a Certificate of Completion is issued or the final invoice is paid if no Certificate of Completion is issued. The Contractor shall, upon request from the Departmental Representative, make said records available for copy, audit or inspection to any person(s) acting on behalf of Canada.
2. The Contractor shall cause all Subcontractors, and all other Persons or entities directly or indirectly involved with the Work, to comply with the requirements of GC 2.3.1.

GC 2.4 Notices

1. Any notice shall be in writing and may be delivered by hand, by courier, by registered or regular mail, or by facsimile or other electronic means that provides a paper record of the text of the notice. The notice shall be addressed to the party for whom it is intended at the address in the Contract or at the last address from which the sender has received notice in accordance with this

GENERAL CONDITIONS FOR MINOR WORKS (Continued)

section. Any notice shall be deemed to be effective on the day it is received at that address or four (4) days after being sent, whichever is the earlier.

GC 3 EXECUTION OF THE WORK

GC 3.1 Material, Plant, and Real Property Become the Property of Canada

1. All Material and Plant used or consumed for the purposes of the Work shall be the property of Canada. The Material and Plant shall be used only for the purposes of the Work, and shall not be removed from the site of the Work until so approved by the Departmental Representative.
2. The Contractor shall be liable for all loss or damage to Material or Plant that is the property of Canada by virtue of this section.

GC 3.2 Cooperation with Other Contractors

1. The Contractor shall cooperate fully with other contractors or workers sent onto the site of the Work by the Departmental Representative.
2. If, at the time the Contract was executed: the Contractor could not have reasonably foreseen the sending of other contractors or workers onto the site of the Work; and, the Contractor incurs extra costs in complying with GC 3.2.1; and, the Contractor gives written notice of claim for the extra costs within ten (10) days from the date upon which the other contractors or workers were sent onto the site of the Work; then, Canada shall pay an additional amount to the Contractor, calculated pursuant to GC 5.7.

GC 3.3 Use of the Work and Cleanup of Site

1. The Contractor shall maintain the site of the Work in a tidy condition and free from the accumulation of waste material throughout the duration of the Contract.
2. Before the Departmental Representative issues the Certificate of Completion or approves payment of the final invoice, the Contractor shall remove all materials, tools, construction machinery, equipment, waste products and debris from the site of the Work.
3. Where the Work affects occupied portions of a building, the Contractor shall ensure continuity of all building services and shall ensure safe access for all persons requiring access to said building.

GC 3.4 Warranty and Rectification of Defects

1. Without restricting any warranty or guarantee implied or imposed by law or any extended warranty specified in the Contract, the Contractor shall, upon notice from the Departmental Representative and at its own expense, rectify all defects which appear in the Work within twelve (12) months from the date of issuance of the Certificate of Completion pursuant to GC 5.6.1, or from the date of the negotiable instrument issued as final payment if a Certificate of Completion is not issued, whichever is applicable.
2. The notice referred to in GC 3.4.1 shall be in writing and shall include the number of days within which the defect or fault is to be rectified.
3. The Contractor shall transfer and assign, to Canada, any subcontractor, manufacturer or supplier extended warranties or guarantees implied or imposed by law or contained in the contract documents covering periods beyond the twelve (12) months stipulated above. Extended

GENERAL CONDITIONS FOR MINOR WORKS (Continued)

warranties or guarantees referred to herein shall not extend the twelve (12) month period whereby the Contractor must rectify and make good any defect or fault that appears in the work or comes to the attention of Canada.

GC 4 PROTECTION, HEALTH AND SAFETY

GC 4.1 Material, Plant and Real Property Supplied by Canada

1. The Contractor, having care, custody and control of the Work and its site, shall be responsible for any loss or damage, excluding reasonable wear and tear, to any property of Canada arising out of the performance of the Work whether or not such loss arises from causes beyond the Contractor's control.

GC 4.2 Construction Safety

1. The Contractor shall be responsible for the health and safety of all persons granted access to the site of the Work and for initiating, maintaining and supervising all safety inspections, precautions and programs in connection with the performance of the Work in accordance with the health and safety legislation in force in the Province where the Work is being performed.

GC 5 TERMS OF PAYMENT

GC 5.1 Definitions

For the purposes of this section:

- Payment Period means a period of thirty (30) days or such other longer period as may be agreed between the Contractor and the Departmental Representative.
- An amount is Due and Payable when it is due and payable by Canada to the Contractor in accordance with the terms of the Contract.
- An amount is Overdue when it remains unpaid after the day upon which it is due and payable.
- Date of Payment means the date of the negotiable instrument of an amount due and payable by the Receiver General for Canada.
- Fixed Price Arrangement means that part of the Contract that prescribes a lump sum as payment for performance of the Work to which it relates.
- Unit Price Arrangement means that part of the Contract that prescribes the product of a Price Per Unit multiplied by a number of Units of Measurement of a Class as payment for performance of the Work to which it relates.
- Price Table means the table set out in the BID AND ACCEPTANCE FORM.
- Bank Rate means the rate of interest established from time to time by the Bank of Canada as the minimum rate at which the Bank of Canada makes short term advances to members of the Canadian Payments Association.
- Average Bank Rate means the simple arithmetic mean of the Bank Rates in effect at 4:00 pm Eastern Time each day during the calendar month which immediately precedes the calendar month in which payment is made.
- Duration of the Work means the number of calendar days required to complete the Work, commencing on the first day following receipt by the Contractor of the fully executed Contract and ending the day on which the Departmental Representative verifies that the Work has been satisfactorily completed.

GC 5.2 Payment - General Provisions

GENERAL CONDITIONS FOR MINOR WORKS (Continued)

1. It is a condition precedent to Canada's obligation under GC 5.3.5 that the Contractor has made and delivered to the Departmental Representative, a statutory declaration as described in GC 5.2.2.
2. A statutory declaration in a form acceptable to Canada shall contain a declaration that the Contractor has complied with all lawful obligations with respect to workers and that all lawful obligations towards Subcontractors and Suppliers in respect of the Work under the Contract have been fully discharged.
3. A payment by Canada pursuant to this section shall not be construed as evidence that the Work is satisfactory or in accordance with the Contract.
4. Delay in making payment by Canada under the Contract shall not constitute a breach of Contract.
5. Without limiting any right of setoff or deduction given or implied by law or elsewhere in the Contract, Canada may retain from amounts payable to the Contractor under the Contract, any amount payable to Canada by the Contractor under the Contract or any other current contract.
6. No additional payment shall be made for delays where the cause of the delay was under the control of the Contractor.
7. Except as provided for in these General Conditions, the amount payable to the Contractor under the Contract shall not be increased or decreased by reason of any increase or decrease in cost of the Work brought about by any increase in the cost of Labour, Plant or Material.
8. In the event of a change, including a new imposition or repeal of any tax, customs or other duty, charge, or any similar imposition that is imposed under sales or excise tax legislation of the Government of Canada or any Provincial or Territorial legislation, affects the cost of the Work to the Contractor, and occurs after the date of submission by the Contractor of the Contractor's bid, the contract amount shall be adjusted by an amount equal to the increased or decreased cost to the Contractor, which amount shall be determined through a detailed examination of the Contractor's records.
9. It is a term of every contract providing for the payment of any money by Her Majesty that payment under that contract is subject to there being an appropriation for the particular service for the fiscal year in which any commitment under that contract would come in course of payment. Section 40, *Financial Administration Act*, R.S., 1985, c. F-11, s. 40.

GC 5.3 Progress Payments

1. Where the duration of the Work is greater than thirty (30) days, the Contractor shall be entitled to receive monthly progress payments upon submitting a progress claim in a form approved by the Departmental Representative. Where the duration of the Work is less than thirty (30) days, the Contractor shall submit a progress claim after the Work is complete.
2. On the expiration of a Payment Period, the Contractor shall deliver to the Departmental Representative:
 - (a) a written progress claim that fully describes any part of the Work that has been satisfactorily completed and any Material that was delivered to the site of the Work but not incorporated into the Work during the Payment Period for which the progress claim relates;
 - (b) a completed and signed statutory declaration as described in GC 5.2.2; and

GENERAL CONDITIONS FOR MINOR WORKS (Continued)

- (c) in the case of the initial progress claim and the request for final payment, satisfactory evidence of compliance with workers compensation legislation that is applicable to the place of the Work.
- 3. Not later than ten (10) days after receipt of a progress claim properly submitted in accordance with GC 5.3.2, the Departmental Representative shall issue a progress report, a copy of which shall be given to the Contractor.
- 4. A progress report shall indicate the value of the part of the Work and Material described in the progress claim that, in the opinion of Canada:
 - (a) is in accordance with the Contract; and
 - (b) was not included in any other progress report related to the Contract.
- 5. Not later than thirty (30) days after the receipt by the Departmental Representative of a properly submitted progress claim and supporting documentation, Canada shall make a progress payment to the Contractor in an amount that is equal to one of the following:
 - (a) 90 percent of the value that is indicated in the progress report; or
 - (b) If the Departmental Representative is satisfied that the Work is substantially complete and is acceptable for use by Canada, 100 percent of the value of the Work and Material that is in accordance with the Contract, less amounts previously paid for under the Contract, less the amount equal to the estimated cost of completing the Work and the estimated cost of rectifying defects and faults in the Work as determined by the Departmental Representative; or
 - (c) If the Departmental Representative is satisfied that the Work is complete, 100 percent of the value of the Work that is in accordance with the Contract less amounts previously paid for under the Contract;plus Applicable Taxes and less the aggregate of any amounts payable to or costs and damages claimed by Canada or by a Claimant against the Contractor.
- 6. The Departmental Representative reserves the right to increase or decrease the quantities submitted by the Contractor if there is a disagreement between the Contractor's invoiced quantities and the quantities shown in the records maintained at the site of the Work.
- 7. Subject to GC 5.3.8, GC 5.3.9 and GC 5.3.10, the Departmental Representative and the Contractor may, by an agreement in writing, amend a Price Per Unit as set out in the Price Table for any Class of Labour, Plant or Material provided the Certificate of Measurement shows that the Authorized Quantity of the Class of Labour, Plant or Material actually performed, used or supplied by the Contractor in performing the Work is:
 - (a) less than 85 percent of the Estimated Total Quantity; or
 - (b) in excess of 115 percent of the Estimated Total Quantity.
- 8. In no event shall the total amount of an Item set out in the Price Table that has been amended pursuant to GC 5.3.7 (a) exceed the amount that would have been Payable to the Contractor had the Estimated Total Quantity actually been performed, used, or supplied.
- 9. An amendment that is made necessary by GC 5.3.7 (b) shall apply only to the quantities that are in excess of 115 percent.
- 10. Where the Departmental Representative and the Contractor fail to agree on the amount of any adjustment to a Price Per Unit as contemplated by GC 5.3.7, the amended Price Per Unit shall be determined in accordance with GC 5.7.

GENERAL CONDITIONS FOR MINOR WORKS (Continued)

GC 5.4 Interest on Overdue Accounts

1. Canada shall be liable to pay, to the Contractor, simple interest at the Average Bank Rate plus 3 percent per annum on any amount that is Overdue. The interest shall apply from the date such amount becomes Overdue until the day prior to the Date of Payment inclusively.
2. Interest shall be paid to the Contractor without demand on Overdue payments, except, in respect to amounts which are less than fifteen (15) days Overdue, in which case, no interest shall be paid unless the Contractor so demands.
3. Canada shall not be liable to pay interest where Canada is not responsible for the delay in paying the Contractor.

GC 5.5 Payment in the Event of Termination

1. If the Contract is terminated pursuant to GC 7.4, Canada shall pay the Contractor:
 - (a) an amount, as agreed upon by the Contractor and the Departmental Representative, for all Labour, Plant and Material performed, used or supplied by the Contractor as at the date of termination plus
 - (i) any fully supported termination costs incurred by the Contractor, less
 - (ii) any amounts payable to or costs and damages claimed by Canada or by a Claimant, against the Contractor; or
 - (b) failing such an agreement, an amount calculated in accordance with GC 5.7.2.

GC 5.6 Final Completion

1. A Certificate of Completion shall be issued to the Contractor on the date on which the Work has been completed and the Contractor has complied with the Contract and all orders and directions made pursuant thereto, all to the satisfaction of the Departmental Representative.
2. Where the Contract is, in whole or in part, a Unit Price Arrangement, the Departmental Representative shall, at the same time as the issuance of the Certificate of Completion, issue a Certificate of Measurement setting out the Authorized Quantities used or employed in respect of the classes and units set out in the Price Table under the BID AND ACCEPTANCE FORM and any subsequent amendments thereto, such certificate to be binding upon the Contractor and Canada.

GC 5.7 Determination of Price

1. By mutual agreement:
 - (a) where a Lump Sum Arrangement applies to the Contract or a part thereof, the price of any change shall be the aggregate estimated cost of Labour, Plant and Material that is required for the change as agreed upon in writing by the Contractor and Canada, and include an allowance for overhead, margin and the risk of undertaking the work within the stipulated amount;
 - (b) where a Unit Price Arrangement applies to the Contract or a part thereof, the Contractor and Canada may, by agreement in writing, add Items, Units of Measurement, Estimated Total Quantities and Price Per Units to the Price Table;
 - (c) a Price Per Unit referred to in GC 5.7.1 (b) shall be determined on the basis of the aggregate estimated cost of Labour, Plant and Material that is required for the additional Item as agreed upon by the Contractor and Canada, and include an allowance for overhead, margin and the risk of undertaking the work;

GENERAL CONDITIONS FOR MINOR WORKS (Continued)

- (d) to facilitate approval of the price of the additional Item, the Contractor shall submit a cost estimate breakdown identifying, as a minimum, the estimated cost of Labour, Plant, Material, each subcontract amount, and the amount of the appropriate percentage allowance;
- (e) if no agreement can be reached as contemplated in GC5.7.1 (a), the price shall be determined in accordance with GC 5.7.2; and
- (f) if no agreement can be reached as contemplated in GC 5.7.1 (b) and GC 5.7.1 (c), the Departmental Representative shall determine the Class and the Unit of Measurement of the Item of Labour, Plant or Material and the Price Per Unit shall be determined in accordance with GC 5.7.2.

2. Following Completion of the Additional Work

- (a) Where it is not possible to predetermine, or where there is failure to agree upon the price of a change in the Work, the price of the change shall be equal to the aggregate of:
 - (i) all reasonable and proper amounts actually expended or legally payable by the Contractor in respect of the Labour, Plant and Material that fall within one of the classes of expenditure described in GC 5.7.2(b), that are directly attributable to the performance of the Contract; plus
 - (ii) an allowance for profit and all other expenditures or costs equal to 10 percent of the sum of the amounts referred to in GC 5.7.2 (a)(i); plus
 - (iii) interest, if any, paid by the Contractor on the amounts determined under GC 5.7.2 (a)(i) and (ii), calculated in accordance with GC 5.4.
- (b) The cost of Labour, Plant and Material referred to in GC 5.7.2 (a) shall be limited to the following categories of expenditure:
 - (i) payments to Subcontractors and suppliers;
 - (ii) wages, salaries and traveling expenses of employees of the Contractor located at the site of the Work and that portion of wages, salaries, bonuses, living and traveling expenses of personnel of the Contractor generally employed at the head office or at a general office of the Contractor provided they are actually and properly engaged on the Work under the Contract;
 - (iii) assessments payable under any statutory authority relating to workers' compensation, employment insurance, pension plan or holidays with pay, provincial health or insurance plans, environmental reviews, and GST/HST collection costs;
 - (iv) rent that is paid for Plant, or an amount equivalent to the said rent if the Plant is owned by the Contractor, that is necessary for and used in the performance of the Work, if the rent or the equivalent amount is reasonable and use of that Plant had been approved by the Departmental Representative;
 - (v) payments for maintaining and operating Plant necessary for and used in the performance of the Work, and payments for effecting repairs thereto that, in the opinion of the Departmental Representative, are necessary for the proper performance of the Contract, other than payments for any repairs to the Plant arising out of defects existing before its allocation to the Work;
 - (vi) payments for Material that is necessary for and incorporated in the Work, or that is necessary for and consumed in the performance of the Contract;
 - (vii) payments for preparation, delivery, handling, erection, installation, inspection, protection and removal of the Plant and Material necessary for and used in the performance of the Contract; and
 - (viii) any other payments made by the Contractor with the approval of the Departmental Representative that are necessary for the performance of the Contract in accordance with the Contract Documents.

GC 5.8 Claims Against and Obligations of the Contractor or Subcontractor

GENERAL CONDITIONS FOR MINOR WORKS (Continued)

1. The Contractor shall ensure that all its lawful obligations arising out of the performance of the Work are discharged and satisfied at least as often as the Contract requires Canada to pay the Contractor. The Contractor shall provide the Departmental Representative with a Statutory Declaration, as referred to in GC 5.2.2. If any third party claims and outstanding obligations exist under the Contract, a Statutory Declaration shall also be accompanied by letter documentation that clearly identifies the existence and condition of any third party disputed claims and outstanding obligations.
2. In order to discharge lawful obligations of and satisfy lawful claims against the Contractor or a Subcontractor arising out of the performance of the Work, Canada may:
 - (a) pay an amount from money that is due and payable to the Contractor pursuant to the Contract directly to the claimant against the Contractor or the Subcontractor; or
 - (b) withhold from any amount that is due and payable to the Contractor pursuant to the Contract the full amount of the claim or any portion thereof. Monies withheld for this purpose shall not be subject to any interest payment in the event such claims are rejected.
3. The amount referred to in GC 5.8.2 (a) shall be that amount which the Contractor would have been obliged to pay to such claimant had the provisions of the Provincial or Territorial lien legislation, or in the province of Quebec, the law relating to mortgage, been applicable to the Work. Any such claimant need not comply with the provisions of such legislation setting out the steps by way of notice, registration, or otherwise as might have been necessary to preserve or perfect any claim for lien or mortgage which the claimant might have had.
4. For the purposes of GC 5.8, a claim shall be considered lawful when it is so determined:
 - (a) by a court of competent jurisdiction;
 - (b) by an arbitrator duly appointed to arbitrate the said claim; or
 - (c) by written notice delivered to the Departmental Representative and signed by the Contractor authorizing payment of the said claim(s).
5. A payment made pursuant to GC 5.8.2 is, to the extent of the payment, a discharge of Canada's liability to the Contractor under the Contract and may be deducted from any amount payable to the Contractor under the Contract.
6. GC 5.8.2 shall only apply to claims and obligations where:
 - (a) the notification of which has set forth the amount claimed to be owing and the person who by Contract is primarily liable;
 - (b) the notification or a copy of the notification was received by the Departmental Representative in writing before final payment is made to the Contractor and within one hundred and twenty (120) days of the date on which the claimant:
 - (i) should have been paid in full under the claimant's Contract with the Contractor or Subcontractor where the claim is for money that was lawfully required to be held back from the claimant; or
 - (ii) performed the last of the labour or furnished the last of the Plant or Material pursuant to the claimant's Contract with the Contractor or Subcontractor where the claim is not for money referred to in GC 5.8.6 (b)(i); and
 - (c) the proceedings to determine the right to payment for the claim shall have commenced within one year from the date that the notice referred to in GC 5.8.6 (b) was received by the Department Representative.
7. The Departmental Representative shall inform the Contractor in writing of receipt of any notification of claim and of the intention of Canada to withhold funds pursuant to GC 5.8.2. The Contractor may, at any time thereafter and until payment is made to the claimant, post with Canada, security in the form of a Claimant's Payment Bond acceptable to Canada and in an

GENERAL CONDITIONS FOR MINOR WORKS (Continued)

amount equal to the value of the said claim. Upon receipt of such security Canada shall release to the Contractor any funds which would be otherwise payable to the Contractor, that were withheld pursuant to the provisions of GC 5.8.2.

GC 6 CHANGES IN THE WORK

GC 6.1 Changes in the Work

1. Canada shall have the right to order additional Work, dispense with, or change the whole or any part of the Work described in the Drawings and Specifications or Scope of the Work.
2. The Departmental Representative shall decide whether anything done or not done as a result of directions given under GC 6.1.1 has increased or decreased the cost of the Work to the Contractor and where the cost of the Work has increased or decreased, the amount payable under the Contract shall be increased or decreased by an amount calculated in accordance with GC5.7.
3. Any change in the terms of the Contract, other than changes that may be ordered by Canada or the Departmental Representative pursuant to GC 6.1.1, may be made only by agreement in writing between Canada and the Contractor.

GC 6.2 Changes in Subsurface Conditions and Delays by Canada

1. No extra payment shall be made to the Contractor for any extra expense, loss or damage for any reason unless Canada shall certify that such extra expense, loss or damage is directly attributable to:
 - (a) a substantial difference between the subsurface conditions as indicated in the Drawings and Specifications or Scope of Work and the actual conditions found at the site of the Work; or
 - (b) the neglect or delay by Canada, occurring after the date of award of the Contract:
 - (i) in providing any information or the doing of any act which Canada is required expressly by the Contract to do or as required by a known custom of the trade; or
 - (ii) in suspending the Work pursuant to GC 7.3.
2. The Contractor shall, within ten (10) days immediately after encountering such subsurface conditions or such neglect or delay, give written notice to the Departmental Representative of a claim for such extra expense, loss or damage. Failure to provide such written notice shall render the claim null and void.
3. The amount of any extra payment made under this section shall be calculated in accordance with GC 5.7.
4. If, in the opinion of the Departmental Representative, any difference in subsurface conditions referred to in GC 6.2.1 results in a savings to the Contractor, the amount of said savings shall be deducted from the Contract Amount owing to the Contractor.

GC 6.3 Extension of Time

1. Upon written application by the Contractor made before the date fixed for the completion of the Work, Canada may extend the time for completion of the Work if, in the opinion of Canada causes beyond the control of the Contractor have delayed its completion.
2. If the Contractor does not complete the Work by the day fixed for its completion, but completes it thereafter, the Contractor shall:

GENERAL CONDITIONS FOR MINOR WORKS (Continued)

- (a) pay all Canada's inspection costs relating to the Work incurred after the stipulated completion date; and
- (b) compensate Canada for any loss or damage resulting from the failure by the Contractor to complete the Work by the completion date fixed by the Contract.

Unless, in the opinion of Canada, such delay was due to causes beyond the control of the Contractor or it is in the public interest to waive the whole or any part of the payment.

GC 7 DEFAULT, SUSPENSION OR TERMINATION OF CONTRACT

GC 7.1 Taking the Work Out of the Contractor's Hands

1. By giving notice in writing to the Contractor, Canada may take all or any part of the Work out of the Contractor's hands, and may employ such means as Canada sees fit to have the Work completed if the Contractor:
 - (a) fails to remedy any delay in the commencement or default in the execution of the Work to the satisfaction of the Departmental Representative within six (6) days of Canada giving written notice to the Contractor to do so;
 - (b) defaults in the completion of any part of the Work within the time fixed by the Contract for its completion;
 - (c) becomes insolvent or commits an act of bankruptcy and has neither made a proposal to its creditors nor filed a notice of intention to make such a proposal pursuant to the *Bankruptcy and Insolvency Act*;
 - (d) abandons the Work;
 - (e) makes an assignment contrary to GC 1.3; and or
 - (f) otherwise fails to observe or perform any of the provisions of the Contract.
2. If the whole or any part of the Work is taken out of the Contractor's hands, the Contractor's right to any further payment that is due or accruing due under the Contract is extinguished.
3. The Contractor shall be liable to pay Canada, upon demand, an amount that is equal to the sum of all losses and damages incurred or sustained by Canada in respect of the Contractor's failure to complete the Work.
4. If the whole or any part of the Work that is taken out of the Contractor's hands pursuant to GC 7.1.1 is completed by Canada, the Departmental Representative shall calculate the amount, if any, of the holdback or progress claims that had accrued and was due prior to the date on which the Work was taken out of the Contractor's hands.
5. If it is determined that there is an amount that is not required for the purposes of having the Work performed or of compensating Canada for any other loss or damage incurred or sustained by reason of the Contractor's default, Canada may then pay the Contractor the amount determined not to be required pursuant to GC 7.1.4.

GC 7.2 Effect of Taking the Work Out of the Contractor's Hands

1. The taking of the Work or part thereof out of the Contractor's hands pursuant to GC 7.1.1 does not operate so as to relieve or discharge the Contractor from any obligations under the Contract or imposed upon the Contractor by law except the obligation to complete the performance of that part of the Work that was taken out of the Contractor's hands.
2. All Plant and Material and the interest of the Contractor in all real property, licenses, powers and privileges acquired, used, provided or consumed by the Contractor under the Contract shall continue to be the property of Canada without compensation to the Contractor.

GENERAL CONDITIONS FOR MINOR WORKS (Continued)

3. When the Departmental Representative certifies that any Plant, Material or any interest of the Contractor referred to in GC 7.2, is no longer required for the purpose of the Work, or that it is not in the interests of Canada to retain that Plant, Material or interest, it shall revert to the Contractor.

GC 7.3 Suspension of the Contract

1. Canada may, upon giving notice in writing to the Contractor, suspend the performance of the Work at any time. The Contractor shall comply with such notice immediately, subject to any conditions that may be stipulated in the notice.
2. If Canada suspends the Work for thirty (30) days or less the Contractor shall, subject to its remedy under GC 5.7, complete the Work when called upon to do so. If Canada suspends the Work for a period in excess of thirty (30) days, the Contractor may request that Canada terminate the Contract pursuant to GC 7.4.
3. It is the responsibility of the Contractor to mitigate all costs during the suspension period.

GC 7.4 Termination of the Contract

1. Canada may terminate the Contract at any time by giving notice of termination in writing to the Contractor and upon receipt of such notice the Contractor shall cease all operations in performance of the Contract, subject to any conditions that may be stipulated in the notice.
2. Termination under GC 7.4.1 shall not relieve the Contractor of any legal or contractual obligations other than that portion of Work that remains to be completed at the time of the termination.
3. Payment, in event of termination under this subsection, shall be made pursuant to the provision of GC 5.5.

GC 8 DISPUTE RESOLUTION

1. The Contractor may, within 10 days after the communication to the Contractor of any decision or direction referred to in GC2.1(b) and GC6.1, protest that decision or direction.
2. A protest referred to in GC8.1 shall be in writing, contain full reasons for the protest, be signed by the Contractor and be given to Canada.
3. If the Contractor gives a protest pursuant to GC8.2, any compliance by the Contractor with the decision or direction that was protested shall not be construed as an admission by the Contractor of the correctness of that decision or direction, or prevent the Contractor from taking whatever action the Contractor considers appropriate in the circumstances.
4. The giving of a protest by the Contractor pursuant to GC8.2 shall not relieve the Contractor from complying with the decision or direction that is the subject of the protest.
5. Subject to GC8.6, the Contractor shall take any action referred to in GC8.3 within 3 months after the date of the Certificate of Completion referred to in GC5.6 and not afterwards, except where it is otherwise provided by law.
6. The Contractor shall take any action referred to in GC8.3 resulting from a direction under GC3.4, within 3 months after the expiry of a warranty or guarantee period and not afterwards, except where it is otherwise provided by law.

GENERAL CONDITIONS FOR MINOR WORKS (Continued)

7. Subject to GC8.8, if Canada determines that the Contractor's protest is justified, Canada shall pay the Contractor the cost of the additional labour, Plant and Material necessarily incurred by the Contractor in carrying out the protested decision or direction.
8. Costs referred to in GC8.7 shall be calculated in accordance with GC5.7.

GC 9 INDEMNIFICATION AND INSURANCE

GC 9.1 Indemnification

1. The Contractor shall indemnify and save harmless Canada, its servants, agents and all those for whom Canada may be, in law, responsible, from and against all claims, demands, losses, damages, costs and legal proceedings by whomever made, sustained, brought or prosecuted, and in any manner based upon, occasioned by or attributed to the activities of the Contractor, the Contractor's employees, agents or persons for whom the Contractor is, in law, responsible for the performance or purported performance of the Contract, including an infringement or alleged infringement of a patent of invention or any other kind of intellectual property.
2. For the purpose of GC 9.1.1, activities include any act improperly carried out and any omission or delay in carrying out an act.
3. The Contractor's liability to indemnify or reimburse Canada under the Contract shall not affect or prejudice Canada from exercising any rights available to Canada at law or in equity.

GC 9.2 Insurance Contracts

1. The Contractor shall, at the Contractor's expense, obtain and maintain insurance contracts in respect of the work and shall provide evidence thereof to Canada in accordance with the requirements of the INSURANCE TERMS.
2. The insurance contracts referred to in GC 9.2.1 shall:
 - (a) be in a form, of the nature, in the amounts, for the periods and containing the terms and conditions specified in INSURANCE TERMS; and
 - (b) provide for the payment of claims under such insurance contracts in accordance with GC 9.3.

GC 9.3 Insurance Proceeds

1. In the case of a claim payable under a Builders Risk/Installation (All Risks) insurance contract maintained by the Contractor pursuant to GC 9.2, the proceeds of the claim shall be paid directly to Canada, and
 - (a) the monies so paid shall be held by Canada for the purposes of the Contract, or
 - (b) if Canada elects, shall be retained by Canada, in which event they vest in Canada absolutely.
2. In the case of a claim payable under a General Liability insurance contract maintained by the Contractor pursuant to GC 9.2, the proceeds of the claim shall be paid by the insurer directly to the claimant.
3. If an election is made pursuant to GC 9.3.1, Canada may cause an audit to be made of the accounts of the Contractor and of Canada in respect of the part of the work that was lost, damaged or destroyed for the purpose of establishing the difference, if any, between
 - (a) the aggregate of the amount of the loss or damage suffered or sustained by Canada, including any costs incurred in respect of the clearing and cleaning of the Work and its

GENERAL CONDITIONS FOR MINOR WORKS (Continued)

- site and any other amount that is payable by the Contractor to Canada under the Contract, minus any monies retained pursuant to GC 9.3.1 (b); and
- (b) the aggregate of the amounts payable by Canada to the Contractor pursuant to the Contract up to the date of the loss or damage.
4. A difference that is established pursuant to GC 9.3.3 shall be paid forthwith by the party who is determined by the audit to be the debtor to the party who is determined by the audit to be the creditor.
 5. When payment of a deficiency has been made pursuant to GC 9.3.4, all rights and obligations of Canada and the Contractor under the Contract shall, with respect only to the part of the work that was the subject of the audit referred to in GC 9.3.3, be deemed to have been expended and discharged.
 6. If an election is not made pursuant to GC 9.3.1 (b), the Contractor shall, subject to GC 9.3.7, clear and clean the work and its site and restore and replace the part of the work that was lost, damaged or destroyed at the Contractor's expense as if that part of the work had not yet been performed.
 7. When the Contractor clears and cleans the Work and its site and restores and replaces the work referred to in GC 9.3.6, Canada shall pay the Contractor out of the monies referred to in GC 9.3.1 so far as they will thereon to extend.
 8. Subject to GC 9.3.7, payment by Canada pursuant to GC 9.3.7 shall be made in accordance with the Contract but the amount of each payment shall be 100 percent of the amount claimed notwithstanding GC 5.3 a) and b).



INSURANCE TERMS

IN1 GENERAL

- IN1.1 Worker's Compensation
- IN1.2 Indemnification
- IN1.3 Proof of Insurance
- IN1.4 Insured
- IN1.5 Payment of Deductible

IN2 COMMERCIAL GENERAL LIABILITY

- IN2.1 Scope of Policy
- IN2.2 Period of Insurance

IN3 AUTOMOBILE INSURANCE

- IN3.1 Scope of Policy

IN4 BUILDER'S RISK / INSTALLATION FLOATER

- IN4.1 Scope of Policy
- IN4.2 Amount of Insurance
- IN4.3 Period of Insurance
- IN4.4 Insurance Proceeds

IN1 GENERAL

IN1.1 Worker's Compensation

- 1) The Contractor shall provide and maintain Worker's Compensation Insurance in accordance with the legal requirements of the Province or Territory where the work is being carried out.

IN1.2 Indemnification

- 1) The insurance required by the provisions of these Insurance Terms shall in no way limit the Contractor's responsibility under the Indemnification clause of the General Conditions of the contract. Any additional coverage the Contractor may deem necessary to fulfill his obligations under the aforesaid clause shall be at his own discretion and expense.

IN1.3 Proof of Insurance

- 1) Before commencement of the Work, and within thirty (30) days after acceptance of its bid, the Contractor shall deposit with Canada a CERTIFICATE OF INSURANCE (form AAFC / AAC5314) available upon request.
- 2) In the event that the Contractor already possesses an insurance certificate clearly demonstrating that their insurance coverage meets IN2.1 Scope of Policy provisions, then the Contractor may deposit an original copy of this insurance certificate.
- 3) Upon request by Canada, the Contractor shall provide originals or certified true copies of all contracts of insurance maintained by the Contractor pursuant to the provisions contained herein.

IN1.4 Insured

- 1) Each policy shall insure the Contractor and shall include Her Majesty the Queen in right of Canada, represented by the Minister of Agriculture & Agri-Food Canada as an additional Insured, with respect to liability arising out of the operations of the contractor with regard to the work.

INSURANCE TERMS (Continued)

IN1.5 Payment of Deductible

- 1) The payment of monies up to the deductible amount made in satisfaction of a claim shall be borne by the Contractor.

IN2 COMMERCIAL GENERAL LIABILITY

IN2.1 Scope of Policy

- 1) The insurance coverage provided shall not be less than that provided by IBC Form 2100, as amended from time to time, and shall have:
 - (a) an Each Occurrence Limit of not less than \$1,000,000.00 ;
 - (b) a Products/Completed Operations Aggregate Limit of not less than \$1,000,000.00 ; and
 - (c) a General Aggregate Limit of not less than \$2,000,000.00 per policy year, if the policy is subject to such a limit.
- 2) The policy shall either include or be endorsed to include coverage for the following exposures or hazards if the Work is subject thereto:
 - (a) Blasting.
 - (b) Pile driving and caisson work.
 - (c) Underpinning.
 - (d) Removal or weakening of support of any building or land whether such support be natural or otherwise if the work is performed by the insured contractor.
 - (e) Asbestos.
 - (f) Non-owed Automobile Policy.

IN2.2 Period of Insurance

- 1) Unless otherwise directed in writing by Canada, or, otherwise stipulated elsewhere herein, the policy required herein shall be in force and be maintained from the date of contract award until the day of issue of the Certificate of Completion except that the coverage for Completed Operations Liability shall, in any event, be maintained for a period of at least six (6) years beyond the date of the CERTIFICATE OF COMPLETION.

IN3 AUTOMOBILE INSURANCE

IN3.1 Scope of Policy

- 1) Automobile Liability Insurance in respect of licensed vehicles shall have limits of not less than one million dollars inclusive per occurrence for bodily injury, death, and damage to property.

INSURANCE TERMS (Continued)

IN4 BUILDER'S RISK / INSTALLATION FLOATER

IN4.1 Scope of Policy

- 1) The insurance coverage provided by a Builder's Risk policy or an Installation Floater policy shall not be less than that provided by IBC Forms 4042 and 4047, as amended from time to time.
- 2) The policy shall permit use and occupancy of the project, or any part thereof, where such use and occupancy is for the purposes for which the project is intended upon completion.
- 3) The policy may exclude or be endorsed to exclude coverage for loss or damage caused by any of the following:
 - (a) Asbestos.
 - (b) Fungi or spores.
 - (c) Cyber.
 - (d) Terrorism.

IN4.2 Amount of Insurance

- 1) The amount of insurance shall not be less than the sum of the contract value plus the declared value (if any) set forth in the contract documents of all material and equipment supplied by Canada at the site of the project to be incorporated into and form part of the finished Work. If the value of the Work is changed, the policy shall be changed to reflect the revised contract value.

IN4.3 Period of Insurance

- 1) Unless otherwise directed in writing by Canada, or, stipulated elsewhere herein, the policy required herein shall be in force and be maintained from prior to the commencement of work until the day of issue of the CERTIFICATE OF COMPLETION.

IN4.4 Insurance Proceeds

- 1) The policy shall provide that the proceeds thereof are payable to Her Majesty or as Canada may direct in accordance with GC 9.3 Insurance Proceeds.
- 2) The Contractor shall, without delay, do such things and execute such documents as are necessary to effect payment of the proceeds.

BID AND ACCEPTANCE FORM
CONSTRUCTION CONTRACT - MINOR WORKS

Solicitation / File Number: 18-1163
Project: CEF18 0174
Contract: 18-1163

MAIL OR DELIVER BID TO:
K.W. Neatby Building (Building 20)
Central Experimental Farm
960 Carling Ave.
Ottawa, ON
K1A 0C6

BID CLOSING TIME:
Wednesday, September 26, 2018
Day of week, Month, Day, Year
at 02:00 AM PM local time.

DESCRIPTION OF WORKS:
Building 82 Restoration

INSTRUCTIONS TO BIDDERS:
Bidders shall be governed by the following instructions:
- SPECIAL INSTRUCTIONS TO BIDDERS - Form AAFC / AAC5318-E
- INSTRUCTIONS TO BIDDERS - Form AAFC / AAC5319-E

The following additional documents form an attachment to this BID AND ACCEPTANCE FORM:

No additional document attachments
 Statement of Equipment
 List of Subcontractors
 List of Suppliers

OFFER AND AGREEMENT

1. The undersigned bidder (hereinafter called the "Contractor") hereby offers to Her Majesty the Queen in right of Canada, as represented by the Minister of Agriculture and Agri-Food (hereinafter called "Canada"), to furnish all necessary labour, plant and material and to execute and complete in a satisfactory and workmanlike manner all the work required under this contract for the consideration of the unit or lump sum price or prices set forth in the Price Table below. The Contractor agrees that these prices include all applicable provincial sales taxes, ancillary taxes and any commodity tax. Note: Do not include Applicable Taxes (GST/HST/QST) as defined in the General Conditions in price(s).

PRICE TABLE					
Item	Class of Labour, Plant, or Material	Unit of Measurement	Estimated Total Quantity	Price Per Unit	Estimated Total Price
01	Building 82 Foundation	EA	1	N/a	
NOTE: Both price per unit and estimated total price must be filled in for each item in the Price Table. All estimated total prices will be subject to verification by Canada. In case of variation between the price per unit and the estimated total price, the price per unit will be considered to be the price bid.				Total Bid	

2. The Contractor shall perform and complete the Work on or before 2018-10-31.
3. The Contractor hereby acknowledges receipt of the following addenda to the bid documents (give number and date of each):
Addenda numbers: _____ Dates: _____
4. The Contractor agrees that this offer: supersedes and cancels all communications, negotiations, and agreements relating to the work other than contained in this completed bid or any amendment incorporated by mutual agreement between the Contractor and Canada before acceptance of this Offer and Agreement; is irrevocable for 30 days after the Bid Closing Time shown hereon.
5. The Contractor agrees, that the complete bid together with and subject to all the provisions contained herein shall, when accepted and executed on behalf of Canada, constitute a binding contract between the Contractor and Canada.
6. The following additional documents form an attachment to a binding contract:
6.1 GENERAL CONDITIONS FOR MINOR WORKS - Form AAFC / AAC5316-E

BID AND ACCEPTANCE FORM (Continued)

6.2 Specifications

6.3 Insurance Terms

CONTRACTOR'S FULL BUSINESS NAME (Please print or type)

CONTRACTOR'S BUSINESS ADDRESS (for all purposes of or incidental to the contract)

Unit/Suite/Apt.	Street number	Number suffix	Street name	Street type	Street direction
PO Box or Route Number		Municipality (City, Town, etc.)		Province	Postal code

Telephone number	Ext.	Facsimile number	E-mail (optional)	GST/HST number
------------------	------	------------------	-------------------	----------------

Attested to and Delivered on Behalf of the Contractor this _____ day of _____, _____.
Month Year

CONTRACTOR'S or, where applicable, SIGNING OFFICER'S SIGNATURE(S)	TITLE(S)	In the presence of: WITNESS SIGNATURE(S)
_____	_____	_____
_____	_____	_____

NOTE: Corporate Firms shall affix their Corporate Seal if applicable.

(FOR DEPARTMENTAL USE ONLY)

Accepted and Executed on Behalf of Canada this _____ day of _____, _____.
Month Year

SIGNATURE	TITLE	In the presence of: WITNESS SIGNATURE
_____	_____	_____

Bid opened in _____ on _____, _____ at _____ AM PM local time.
Location Day of week Month Day Year

in the presence of _____

BID AND ACCEPTANCE FORM (Continued)

INTEGRITY PROVISIONS - LIST OF NAMES
(complete if your bid exceeds \$10,000.00)

If the required list of names has not been received by the time the evaluation of bids is completed, Canada will inform the Bidder of a time frame within which to provide the information. Failure to provide the names within the time frame specified will render the bid non-responsive. Providing the required names is a mandatory requirement for contract award.

Bidders who are incorporated, including those bidding as a joint venture, must provide a complete list of names of all individuals who are currently directors of the Bidder.

Bidders bidding as sole proprietorship, as well as those bidding as a joint venture, must provide the name of the owner(s).

Bidders bidding as societies, firms or partnerships do not need to provide lists of names.



Agriculture and
Agri-Food Canada

Agriculture et
Agroalimentaire Canada

DRAWINGS AND SPECIFICATIONS

#18-1163

FOR

**CEF BUILDING 82
RESTORATION**

PROJECT: CEF18 00174

**CENTRAL EXPERIMENTAL FARM (CEF)
Agriculture and Agri-Food Canada (AAFC)
K.W. Neatby building
960 Carling Avenue
Ottawa, Ontario K1A 0C6**

1 GENERAL

1.1 SECTION INCLUDES

- .1 Materials, design, and execution of concrete formwork and accessories.

1.2 RELATED SECTIONS

- .1 Section 03 20 00 - Concrete Reinforcing
- .2 Section 03 30 00 - Cast-in-Place Concrete

1.3 REFERENCES

- .1 Canadian Standards Association (CSA International):
 - .1 CSA-A23.1-04/A23.2-04, Concrete Materials and Methods of Concrete Construction/Methods of test and Standard Practices for Concrete.
 - .2 CAN/CSA-086-01, Engineering Design in Wood and CSA-O86S1-05, Supplement No. 1 to CAN/CSA-086-01, Engineering Design in Wood.
 - .3 CSA O121-M1978 (R2003), Douglas Fir Plywood.
 - .4 CSA O141-05 Softwood Lumber.
 - .5 CSA O151-04, Canadian Softwood Plywood.
 - .6 CSA O153-M1980 (R2003), Poplar Plywood.
 - .7 CAN/CSA-O325.0-07 Construction Sheathing.
 - .8 CSA O437 Series-93 (R2006), Standards on OSB and Waferboard.
 - .9 CSA S269.1-1975 (R2003), Falsework for Construction Purposes.
 - .10 CAN/CSA-S269.3-M92 (R2003), Concrete Formwork.
 - .11 CSA B111 – 1974 (R2003) Wire Nails, Spikes and Staples.
- .2 Underwriters' Laboratories of Canada (ULC)
 - .1 CAN/ULC-S701-05, Standard for Thermal Insulation, Polystyrene, Boards and Pipe Covering.
- .3 Conform to National Building Code of Canada 2010.

1.4 SUBMITTALS

- .1 Submit shop drawings for formwork and falsework
 - .1 Each shop drawing submission shall bear stamp and signature of qualified professional engineer registered or licensed in the Province of Ontario, and holder of a BCIN number.
- .2 Submit WHMIS MSDS –Material Safety Data Sheets in accordance with Section 01 47 15 – Sustainable Requirements: Construction and Section 02 61 33 Hazardous Materials.
- .3 Indicate method and schedule of construction, shoring, stripping and re-shoring procedures, materials, arrangement of joints, special architectural exposed

finishes, ties, liners, and locations of temporary embedded parts. Comply with CSA S269.1, for falsework drawings. Comply with CAN/CSA-S269.3 for formwork drawings.

- .4 Indicate formwork design data, such as permissible rate of concrete placement, and temperature of concrete, in forms.
- .5 Indicate sequence of erection and removal of formwork/falsework and proposed strengths of concrete at time of stripping forms.

2 PRODUCTS

2.1 MATERIALS

- .1 Formwork Lumber: Plywood and wood formwork materials to CSA-O121, CAN/CSA-O86.1, CSA O437 Series and/or CSA-O153.
 - .1 For concrete not exposed in finished work use square edged, T&G lumber, solid one side or medium density overlaid one side grade plywood or other material, suitable to retain concrete without leakage or distortion.
 - .2 For exposed concrete, use new, square edged, flat, smooth surfaced, high density one side overlaid Douglas Fir Plywood panels, free of holes, surface markings or other defects to CAN/CSA-A23.1.
 - .3 Lumber to CSA-O141.
- .2 Form ties:
 - .1 For unexposed concrete, use removable or snap-off metal ties, fixed or adjustable length, free of devices leaving holes wider or deeper than 25 mm in concrete surfaces. Use no wire ties.
 - .2 For exposed concrete, use snap ties complete with plastic cones and light grey concrete plugs
- .3 Form Liner:
 - .1 Douglas Fir high density overlay medium density overlay to CSA 0121, Canadian Softwood Plywood to CSA O151, Poplar to CSA O153, T and G square edge, grade and thickness to be submitted for review.
 - .2 Waferboard: to CAN/CSA – 0325.00, grade and thickness to be submitted for review.
- .4 Form release agent: Non-staining, non-toxic, low VOC, biodegradable, chemically active release agent containing compounds that react with free lime present in concrete to provide water insoluble soaps, preventing set of film of concrete in contact with form.
- .5 Form stripping agent: colourless mineral oil, non-toxic, biodegradable, low VOC, free of kerosene, with viscosity between 70 and 110s Saybolt Universal, 15 to 24 mm²/s at 40°C, flashpoint minimum 150°C, open cup.

3 EXECUTION

3.1 FABRICATION AND ERECTION

- .1 Verify lines, levels and centres before proceeding with formwork/falsework and ensure dimensions agree with drawings.
- .2 Do not place shores and mud sills on frozen ground.
- .3 Provide site drainage to prevent washout of soil supporting mud sills and shores.
- .4 Fabricate and erect formwork in accordance with CAN/CSA-S269.3 to produce finished concrete conforming to shape, dimensions, locations and levels indicated within tolerances required by CAN/CSA-A23.1/A23.2.
- .5 Align form joints and make watertight. Keep form joints to minimum.
- .6 Construct forms for exposed concrete with joints and tie patterns as indicated and/or as directed. Joint pattern not necessarily based on using standard size panels or maximum permissible spacing of ties.
- .7 Form linings:
 - .1 Do not stagger joints of form lining material. Align joints to obtain uniform pattern.
 - .2 Secure lining taut to formwork to prevent folds.
 - .3 Ensure lining is new material.
 - .4 Ensure lining is dry and free of oil when concrete is poured.
 - .5 Cost of textile lining is included in price of concrete for corresponding portion of work.
- .8 Clean formwork in accordance with CAN/CSA-A23.1, before placing concrete.
- .9 For walls and shearwalls, leave one side of forms open for inspection of reinforcing steel. Close form only after Departmental Representative has reviewed and approved bar placement.
- .10 Re-use of formwork subject to requirements of CAN/CSA-A23.1.

3.2 REMOVAL AND RESHORING

- .1 Leave formwork in place for following minimum periods of time after placing concrete unless otherwise agreed to by Departmental Representative.
 - .1 3 days for walls or as required to meet strength requirements.
 - .2 3 days for footings and abutments or as required to meet strength requirements
- .2 Provide all necessary reshoring of members where early removal of forms may be required or where members may be subjected to additional loads during construction as required.

- .3 Space reshores in each principal direction not more than 3000 mm apart.
- .4 If concrete surfaces require cleaning after form removal, use only pressurized water stream so as not to alter smooth concrete finish.

END OF SECTION

1 GENERAL

1.1 RELATED SECTIONS

- .1 Section 03 30 00 - Cast-In-Place Concrete

1.2 REFERENCES

- .1 National Building Code of Canada 2015
- .2 American Concrete Institute (ACI)
 - .1 SP-66(04) – ACI Detailing Manual 2004
- .3 Reinforcing Steel Institute of Ontario / Canada (RSIO / RSIC):
 - .1 Reinforcing Steel Manual of Standard Practice (2004);
- .4 American Society for Testing and Materials (ASTM):
 - .1 ASTM A82 / A82M-05a, Standard Specification for Steel Wire, Plain, for Concrete Reinforcement;
 - .2 ASTM A184 / A184M-06, Standard Specification for Fabricated Deformed Steel Bar Mats for Concrete Reinforcement;
 - .3 ASTM A185 / A185M-06e1, Standard Specification for Steel Welded Wire Reinforcement, Plain, for Concrete;
 - .4 ASTM A496 / A496M-05, Standard Specification for Steel Wire, Deformed, for Concrete Reinforcement;
 - .5 Rod Mats for Concrete Reinforcement;
 - .6 ASTM A775 / A775M - 06, Standard Specification for Epoxy-Coated Steel Reinforcing Bars.
- .5 Canadian Standards Association (CSA)
 - .1 CAN/CSA-A23.1-04, Concrete Materials and Methods of Concrete Construction.
 - .2 CAN3-A23.3-04, Design of Concrete Structures.
 - .3 CAN/CSA-G30.18-M92 (R2002), Billet-Steel Bars for Concrete Reinforcement.
 - .4 CAN/CSA-G40.21-04, Structural Quality Steel.
 - .5 CAN/CSA-G164-M92 (2003), Hot Dip Galvanizing of Irregularly Shaped Articles.
 - .6 CSA W186-M1990 (R2002), Welding of Reinforcing Bars in Reinforced Concrete Construction.

1.3 SHOP DRAWINGS

- .1 Submit shop drawings and bar lists. Allow ten working days for shop drawing review before commencing fabrication.
- .2 Indicate on shop drawings, bar bending details, lists, quantities of reinforcement and wire mesh, sizes, spacing, locations of reinforcement and mechanical splices

if approved by Departmental Representative, with identifying code marks to permit correct placement without reference to structural drawings. Indicate sizes, spacing and locations of chairs, spacers and hangers. Prepare reinforcement drawings in accordance with Reinforcing Steel Manual of Standard Practice - by Reinforcing Steel Institute of Canada. ANSI/ACI 315 and ACI 315R, Manual of Engineering and Placing Drawings for Reinforced Concrete Structure.

- .3 Indicate (and detail) all proposed construction joints.
- .4 Show reinforced concrete and reinforced masonry walls and beams in full elevation and detail all bars.
- .5 When requested, for slab construction, show top and bottom layer slab reinforcing on separate plans. Detail sections to fully illustrate bar placement at dowels, curbs, openings, changes of elevation, beams, stairs, and areas of congested steel, and wherever else required.
- .6 Detail placement of reinforcing where special conditions occur.
- .7 Design and detail lap lengths and bar development lengths to CAN/CSA-A23.1 and CAN3-A23.3, unless otherwise specified on drawings. Use Class "B" tension splices unless otherwise noted.
- .8 Indicate details for placement of dowels.

1.4 SUBSTITUTIONS

- .1 Substitute different size bars only if permitted in writing by Departmental Representative.

2 PRODUCTS

2.1 MATERIALS

- .1 Reinforcing steel: weldable low alloy steel deformed bars to CAN/CSA-G30.18.
- .2 Welded deformed steel wire fabric: to ASTM A497 / A497M. Provide in flat sheets only.
- .3 Galvanizing of non-prestressed reinforcement: to CSA G164, minimum zinc coating 600g/m².
- .4 Chairs, bolsters, bar supports, spacers adequate for strength and support of reinforcing under construction conditions: to CAN/CSA-A23.1. Use chairs with plastic coated feet where slab and beam soffits will be exposed.
- .5 Mechanical splices: subject to approval of Departmental Representative.
- .6 Plain round bars: to CAN/CSA-G40.21.

2.2 FABRICATIONS

- .1 Fabricate reinforcing steel in accordance with CAN/CSA-A23.1, ACI SP-66 – Detailing Manual, and RSIO/RSIC Reinforcing Steel Manual of Standard Practice unless indicated otherwise..
- .2 Fabricate to tolerances specified by RSIO/RSIC Reinforcing Steel Manual of Standard Practice unless indicated otherwise.
- .3 Obtain Departmental Representative's approval for locations of reinforcement splices other than those shown on placing drawings.
- .4 Upon approval of Departmental Representative, weld reinforcement in accordance with CSA W186.
- .5 Ship bundles of bar reinforcement, clearly identified in accordance with bar bending details and lists. Bundling and transportation of epoxy coated bars shall be in accordance with ASTM A775/A775M.
- .6 Discard and re-fabricate bars having extra bends, cracks, splits, kinks or excessive rust.

2.3 SOURCE QUALITY CONTROL

- .1 Upon request, provide Departmental Representative with certified copy of mill test report of reinforcing steel to be supplied, showing physical and chemical analysis, corresponding to identification tagging of material at the fabrication plant prior to commencing reinforcing work.

3 EXÉCUTION

3.1 PLACING REINFORCEMENT

- .1 Place reinforcing steel to CAN/CSA-A23.1 and as indicated on reviewed shop drawings.
- .2 Set tie wires so that ends are directed into concrete, not toward exposed concrete surfaces. Un-coated metal tie wires shall not project more than 5mm into the concrete cover.
- .3 Do not tack weld reinforcing unless shown on the Structural Drawings, or approved by the Departmental Representative.
- .4 Do not displace reinforcing to accommodate sleeves, inserts, waterstops, reglets, or other cast-in hardware.
- .5 Maximum chair spacing unless otherwise required by the Drawings or by "Reinforcing Steel Manual of Standard Practice":

Bar Size	Chair Spacing
----------	---------------

10M	600mm
15M	1200mm
20M	1600mm
25M	2000mm

Provide additional chairs and support bars as deemed necessary by the Departmental Representative.

- .6 Place welded wire fabric in as long lengths as practical lapping at least one mesh, (200mm minimum) and tie, unless noted on the Drawings.
- .7 Obtain Departmental Representative's approval of reinforcing steel and position before placing concrete. Give 24 hours notice prior to the time at which approval is required. For walls and deep beams, ensure that one side of formwork is left open for inspection of reinforcing steel.
- .8 Clean reinforcing and forms before placing concrete, and adjust reinforcing and forms immediately before concrete is poured, as required, to ensure bars and inserts are placed correctly.
- .9 Obtain approval from Departmental Representative for all construction joint locations. Ensure additional reinforcement at construction joints is available before commencing pour.
- .10 Do not force reinforcing steel inserts or anchor bolts into fresh or semi-hardened concrete.
- .11 Ensure cover to reinforcement is maintained during concrete pour.

3.2 FIELD BENDING

- .1 Do not field bend reinforcing bars partially embedded in concrete, except as indicated in the Contract Documents or permitted by the Departmental Representative.
- .2 When field bending is authorized, bend without heat, applying a slow and steady pressure.
- .3 Replace bars which develop cracks or splits during field bends.

END OF SECTION

1 GENERAL

1.1 RELATED SECTIONS

- .1 Section 03 10 00 - Concrete Forming and Accessories
- .2 Section 03 20 00 - Concrete Reinforcing

1.2 REFERENCES

- .1 Conform to National Building Code of Canada 2015.
- .2 American Society for Testing and Materials (ASTM)
 - .1 ASTM C260-06, Standard Specification for Air-Entraining Admixtures for Concrete.
 - .2 ASTM C494/C494M-05a, Standard Specification for Chemical Admixtures for Concrete.
 - .3 ASTM C1017/C1017M-03, Standard Specification for Chemical Admixtures for use in Producing Flowing Concrete.
- .3 Canadian Standards Association (CSA)
 - .1 CAN/CSA-A3000-03, Cementitious Materials Compendium.
 - .2 CAN/CSA-A23.1-04, Concrete Materials and Methods of Concrete Construction.
 - .3 CAN/CSA-A23.2-04, Methods of Test and Standard Practices for Concrete.

2 PRODUCTS

2.1 MATERIALS

- .1 Portland Cement shall conform to CAN/CSA-A3000-03, Type 10, or as otherwise indicated on Drawings, or in the Soil Report, from the same source for the entire project.
- .2 Where used, supplementary cementing materials, such as cementitious hydraulic slag, blended hydraulic cement and Pozzolanic mineral admixtures shall conform to CAN/CSA-A3000-03.
- .3 Water, fine aggregates, and normal density coarse aggregates shall conform to CAN/CSA-A23.1. Coarse aggregate size to meet the requirements of CAN/CSA-A23.1, Clause 4.2.3., and the drawings. Coarse aggregates for slab-on-grade to be 20mm (minimum) crushed stone.
- .4 Air-entrainment admixtures shall conform to ASTM C260;

- .5 Chemical admixtures shall conform to ASTM C494;
- .6 Pozzolanic mineral admixtures shall conform to ASTM C1017;
- .7 Superplasticizing admixtures shall conform to ASTM C494;
- .8 Non-shrink grout shall be premixed compound consisting of non-metallic aggregate, cement, water reducing and plasticizing agents, of pouring consistency, and containing not less than 50% by mass of cement and not more than 0.06% soluble chloride ion by mass of cement, with an expansion of not less than 0.04% at 28 days, capable of developing compressive strength of 50 MPa at 28 days.
- .9 Dry pack shall be premixed compound of non-metallic aggregate, cement and sufficient water for the mixture to retain its shape when made into a ball by hand and capable of developing a compressive strength of 50MPa at 28 days.

2.2 CONCRETE MIXES

- .1 Prepare concrete mix designs, and be responsible for all mix design costs including related testing.
- .2 Base design on CAN/CSA-A23.1, Clause 4 to produce concretes having the 28 day compressive strengths and slumps specified on the structural drawings. Where compressive strengths or slumps are not noted on the drawings, provide the following:

LOCATION	28 DAY STRENGTH	SLUMP *	CLASS OF EXPOSUR E
All concrete work in areas exposed to de-icing material	35 MPa	75	C-1
Footings unless noted	30 MPa	75	N
Foundation walls	30 MPa	75	F-2

* Obtain these slumps with aid of specified water reducing agent.

- .3 Design mix to meet the specified exposure requirements of CAN/CSA-A23.1, with the appropriate water/cement ratio and entrained air content given in Tables 1 to 9 of A23.1.
- .4 Concrete for all exposed work shall be of uniform colour and aggregate.
- .5 Only use admixtures which have been tested and accepted in mix designs. Obtain the approval of the Departmental Representative before using chemical admixtures, or supplementary cementing materials.
- .6 The use of calcium chloride or chloride-containing admixtures is strictly prohibited, for all concrete mixes.

3 EXECUTION

3.1 PREPARATION

- .1 Obtain Departmental Representative's approval for planned sequence and form of communications before each concrete pour. Do cast-in-place concrete work in accordance with CAN/CSA-A23.1.
- .2 Anchor reinforcement and inserts to ensure they will not be displaced during concrete placement.
- .3 Prior to placing of concrete obtain Departmental Representative's approval of proposed method for protection of concrete during placing and curing in adverse weather.
- .4 Maintain accurate records of poured concrete items to indicate date, location of pour, quality, air temperature and test samples taken.
- .5 Obtain Geotechnical Departmental Representative's approval of foundation bearing surfaces for bearing capacity, depths, and dimensions, prior to placing concrete. Assist Geotechnical Departmental Representative as required. Maintain accurate records of as-built founding elevations, and submit record drawings to Owner.

3.2 CONSTRUCTION

- .1 Placing of Concrete
 - .1 Obtain Departmental Representative's approval of reinforcing placement before placing concrete. Provide Departmental Representative minimum 24 hours notice prior to placing concrete. Notify the Testing Agency in sufficient time to allow necessary tests or other preparatory work to be done. Do not begin to place concrete until the work of other trades affecting concrete is complete. Failure to meet this requirement may be cause for classification of the Work as being defective.
 - .2 Immediately before concrete placement, moisten all absorbent material that will be in direct contact with the fresh concrete. Take care to prevent ponding.
 - .3 Place concrete in accordance with CAN/CSA-A23.1, under the supervision of a competent foreman at all times. Do not permit disapproved or rejected materials on the site.
 - .4 Water, cement, aggregates or admixtures shall not be added to the concrete after the initial introduction of the mixing water to the batch.
 - .5 Ensure reinforcement and inserts are not disturbed during concrete placement and vibration.
- .2 Finishing, General
 - .1 Finish concrete in accordance with CAN/CSA-A23.1.
 - .2 Rub exposed sharp edges of concrete with carborundum to produce 3mm

radius edges unless otherwise detailed.

3.3 CURING

- .1 Cure concrete as specified in CAN/CSA-A23.1.
- .2 Do not use curing compounds that would have a detrimental effect on bonding, adhesion, curing, appearance, or similar qualities of materials to be applied to concrete surfaces. Use only moisture curing (wet burlap with polyethylene sheeting) at a temperature of at least 10°C for surfaces where applied coatings or finishes are incompatible with curing compound, and maintain continuously moist for a minimum of 7 days.

3.4 DEFECTIVE CONCRETE

- .1 Remove damage, discoloured or defective concrete, blemishes, honeycombing, excessive laitance and embedded debris as directed by Departmental Representative.
- .2 Defects shall be repaired at no cost to the Contract.

3.5 WINTER PROTECTION

- .1 Place concrete in cold weather as specified in CAN/CSA-A23.1, Clause 7.4.1.8. Protect concrete from physical damage or reduced strength due to premature drying or weather extremes.
- .2 To ensure that concrete cures without suffering damage, take precautions by protective methods, provision of heat, maintenance of humidity, free circulation of warm moist air at concrete surfaces, and other means made necessary by conditions that arise. Do not use unvented heaters.
- .3 Carry out hot weather concreting in accordance with CAN/CSA-A23.1, Clauses 5.2 and 7.4, including use of approved moisture retention film, if applicable

END OF SECTION

Part 1 General

1.1 RELATED STANDARDS

- .1 National Building Code of Canada, 2015.
- .2 CSA A23.1-14/A23.2-14 – Concrete Materials and Methods of Concrete Construction/Test Methods and Standard Practices for Concrete.
- .3 Occupational Health and Safety Act, Latest Edition.

1.2 SUBMITTALS

- .1 Submit mix designs for ready-mix concrete, to achieve specified strengths and properties.
- .2 Submit Manufacturer's specifications for all epoxy products, concrete bonding agents and polymer repair mortars.

1.3 CONDITIONS

- .1 All conditions of the general contract apply to work of this section.
- .2 Examine work upon which this section depends. Check dimensions on drawings with existing structure. Report all discrepancies to the Departmental Representative, in writing.
- .3 Examine site conditions prior to commencement of work. Absence of written refusal implies acceptance of all existing conditions and shall constitute a waiver of all claims for extras, regarding the quality or quantities of work in this section.
- .4 Co-operate with all other trades, supply any articles to be built-in and notify other trades of any preparation to be made properly attaching and securing any of the work of this section or related sections.
- .5 Submit written description of proposed procedures for pressure grouting work for the review and approval of the Departmental Representative.

1.4 BONDS AND GUARANTEES

- .1 Contractor shall provide to the Owner a single source written guarantee of full faithful performance against deterioration or delamination of the repair areas on the structural slabs for a period of three (3) years from the date of substantial performance of the project as certified by the Departmental Representative.

Part 2 Products

2.1 PRODUCTS

- .1 Epoxy coating material on existing reinforcing steel to be "Sikatop Armatec 110 EpoCem" as manufactured by Sika Canada Inc.
- .2 Concrete bonding slurry to be "Sikatop Armatec 110 EpoCem" as manufactured by Sika Canada Inc.
- .3 Elastomeric sealant for crack repairs to be "Dymeric 240" as manufactured by Tremco Inc., or approved equivalent. Colour to be confirmed by Departmental Representative.

2.2 MATERIALS

- .1 Ready-mix concrete to be 35 MPa (5000 psi) at 28 days; specified slump 80mm at point of delivery; concrete to be proportioned to CAN/CSA-A23.1, Clause 4; concrete to be air entrained in accordance with class C1 Exposure as per CAN/CSA-A23.1. The use of calcium chloride is prohibited. Maximum chloride content to be 0.20% acid soluble chloride by mass of cement as determined by ASTM Test Method C114.
- .2 Coarse aggregate to be non-reactive to alkalis; size to be less than 1/4" (6mm) for 2" topping and 3/8"(10mm) for patch areas less than 3" (75mm) deep. Aggregate size of 3/4" (20mm) may be used in patch areas greater than 3" (75mm) depth.

Part 3 Execution

3.1 REPAIR AREAS

- .1 Specific repair areas will be identified on site by the Departmental Representative.

3.2 SHORING & FORMWORK

- .1 Full shoring is to be installed and maintained from the underside of the structural slabs. Shores to be adjustable steel shore posts with a capacity of 5,000 lbs. at required extension. Submit shoring details for all work bearing the seal and signature of a professional Engineer, registered in Ontario. Shoring to be inspected on a weekly basis by the responsible Engineer. Submit inspection reports to the project Departmental Representative. Shoring to be maintained until new concrete achieves 80% of the specified strength, but not less than 5 days after concrete placement unless noted otherwise.

- .2 Formwork to be 20mm 'formply' or equivalent plywood with suitable form release agent. Falsework to forms to consist of normal 4" x 4" timbers, or equivalent, with adequate shoring and bracing. Contractor to provide and maintain adequate lateral bracing to all formwork and falsework.
- .3 Contractor to provide specific formwork details bearing the seal and signature of a professional Engineer registered in the Province of Ontario. Submit inspection reports from Formwork Engineer prior to each concrete placement.

3.3 CONCRETE REMOVALS / REPAIRS

- .1 Contractor to provide plan and specifications on equipment to be used for concrete removals. Concrete removal equipment shall not be such that it may cause damage to adjacent areas of the concrete wall (to remain) or to adjacent elements to remain or be repaired.
- .2 Sawcut 1/2" around repair area. Remove all loose, unsound, and delaminated concrete as directed by the Departmental Representative. Do not cut reinforcing steel unless otherwise noted.
- .3 Remove concrete to 1" (25mm) minimum beneath all exposed reinforcing steel.
- .4 Reinforcing steel damaged during concrete removal operations will be replaced by the Contractor at no cost to the Owner, as directed by the Departmental Representative.
- .5 Retain all reinforcing steel for examination by the Departmental Representative. Discard and replace only those bars as directed by the Departmental Representative.
- .6 Wirebrush clean all exposed reinforcing steel to a white metal condition.
- .7 Provide and install new reinforcing bars as directed by the Departmental Representative.
- .8 Clean all patch areas to sound concrete using oil free compressed air.
- .9 Coat all existing reinforcing steel with specified epoxy coating. Apply epoxy using stiff brush method. Allow epoxy to cure on steel as per manufacturer's specifications. Provide additional coat of epoxy coating prior to concrete placement.
- .10 Ensure surrounding concrete surfaces of patch area are in saturated, surface dry condition. Where applicable, apply specified bonding slurry to patch areas.

- .11 Where applicable, immediately prior to concrete placement, retighten all shoring.
- .12 Place new concrete in repair areas within 20 minutes of application of bonding slurry. Consolidate concrete into patch areas with vibrators. Provide positive drainage toward exterior edge of balcony.
- .13 Form patch area to original dimension while providing 3/4" (19mm) clear concrete cover to exposed reinforcing steel. Finish exposed surfaces to match original unless otherwise noted or as directed by the Departmental Representative.
- .14 Place wet burlap and polyethylene sheeting over entire patch area immediately after final trowelling. Maintain wet curing for three (3) days minimum.
- .15 Maintain formwork and shoring in place until concrete has reached min. 80% of design strength or for 5 days minimum unless otherwise noted.
- .16 Upon removal of formwork, examine concrete surfaces for defects. Repair and make good all surface defects to the approval of the Departmental Representative.

3.4 TYPICAL DETAILS – CONCRETE REPAIRS

- .1 Refer to following figure for typical detail for repairs to deep concrete delamination on concrete wall. .

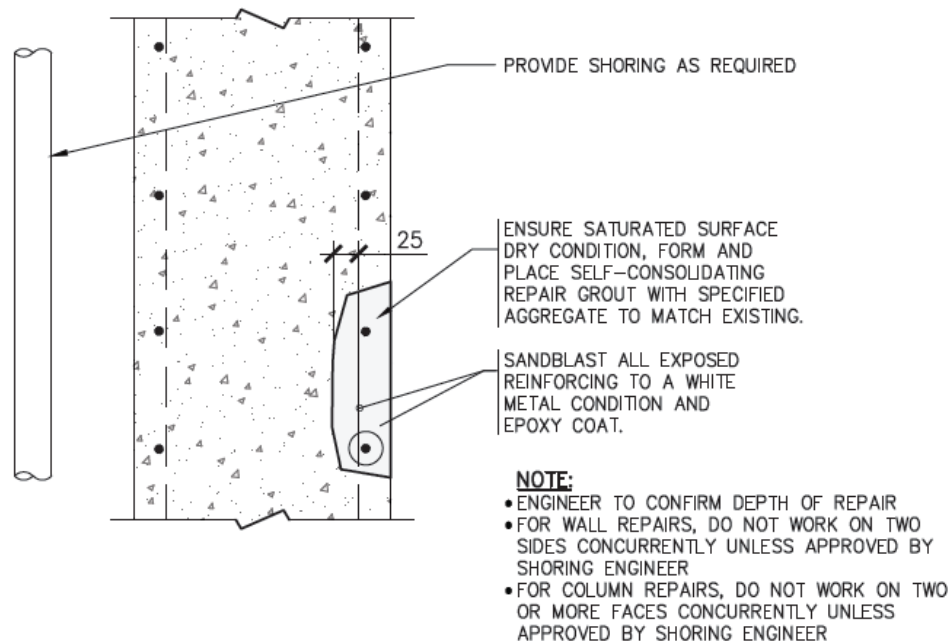

TYPICAL DEEP REPAIR - COLUMN / WALL BASE

1" = 1'-0"

3.5 SITE REVIEW AND TESTING

- .1 Contractor is to provide a minimum of 24 hours notice for any site review or testing work on this project.
- .2 Ensure review by the Departmental Representative of concrete surfaces in patch areas prior to final cleaning operations.
- .3 Ensure review and acceptance by the Departmental Representative of all concrete surfaces and reinforcing steel cleaning operations prior to application of any steel or concrete coating.
- .4 At the Departmental Representatives discretion, tensile bond test may be performed to repair areas. The tensile bond testing shall consist of applying a tensile load of at least 0.9 MPa to four inch diameter cores using an epoxy adhered plate applied to the end surface of the concrete core. Bond test holes to be made good by the Contractor. If bond tests indicate failure to meet specified tensile bond capacity of 0.9 MPa, the Departmental Representative shall have the right to request corrective measures as required including removal and replacement of the repair work.
- .5 Departmental Representative may perform sounding survey of repair areas to verify bond.

- .6 Contractor to fully cooperate with the testing agency and Departmental Representative. Provide all necessary manpower and equipment to allow access to repair areas for review of work or testing.

END OF SECTION

GENERAL NOTES / TYPICAL DETAILS

GENERAL

THE GENERAL NOTES AND TYPICAL DETAILS ARE APPLICABLE TO ALL STRUCTURAL CONDITIONS NOT SPECIFICALLY DETAILED OR REFERENCED ON STRUCTURAL DRAWINGS.

THESE NOTES, DETAILS AND DRAWINGS ARE TO BE READ IN CONJUNCTION WITH THE PROJECT SPECIFICATIONS.

THESE DRAWINGS ARE FOR THE USE OF THE CONSULTANT'S CLIENT ONLY. ALL INFORMATION SHOWN APPLIES TO THIS PROJECT ONLY AND REFLECTS THE BEST JUDGEMENT OF THE CONSULTANT IN LIGHT OF THE AVAILABLE INFORMATION AT THE TIME OF PREPARATION. DECISIONS OR ACTIONS MADE BY THIRD PARTIES BASED ON THE DRAWINGS ARE THE SOLE RESPONSIBILITY OF SUCH PARTIES.

THESE DRAWINGS ARE THE PROPERTY OF ADJELEIAN ALLEN RUBELI LTD.

CODES AND STANDARDS

DESIGN AND CONSTRUCTION TO BE IN ACCORDANCE WITH THE NATIONAL BUILDING CODE OF CANADA 2010, AND THE TERM "BUILDING CODE" THROUGHOUT THESE DRAWINGS MEANS THAT CODE.

THE FOLLOWING STANDARDS MAY BE REFERRED TO BY SHORT FORM ON THESE DRAWINGS:

STANDARD	TITLE/DESCRIPTION	SHORT FORM
ASTM F1554-07	ANCHOR BOLTS, STEEL, 36, 55, AND 105-KSI YIELD STRENGTH	ASTM F1554
CSA A23.1-09	CONCRETE MATERIALS AND METHODS OF CONCRETE CONSTRUCTION	CSA A23.1
CSA A23.2-09	TEST METHODS AND STANDARD PRACTICES FOR CONCRETE	CSA A23.2
CSA A23.3-04	DESIGN OF CONCRETE STRUCTURES	CSA A23.3
CSA 086-09	ENGINEERING DESIGN IN WOOD	CSA 086

REFERENCES ARE TO METRIC VERSIONS OF STANDARDS, UNLESS CONTEXT DICTATES OTHERWISE. SHORT FORM REFERENCES TO CSA STANDARDS MAY SOMETIMES OMIT "CSA".

REFERENCES INCLUDE ALL PUBLISHED ERRATA AND SUPPLEMENTS, UNLESS NOTED OTHERWISE.

ABBREVIATIONS AND SYMBOLS

IN ADDITION TO NORMAL ABBREVIATIONS AND SYMBOLS FOR UNITS OF MEASUREMENT (SI UNITS AND US CUSTOMARY UNITS) OR DEFINED IN THE BUILDING CODE AND VARIABLES DESCRIBED ON THE DRAWINGS, THE FOLLOWING ABBREVIATIONS MAY HAVE BEEN USED ON THESE DRAWINGS, WITH OR WITHOUT PERIODS AND SOMETIMES IN COMBINATION:

AFF	ABOVE FINISHED FLOOR	L.L.	LIVE LOAD OR LOWER LAYER
B	BOTTOM	LLH	LONG LEG HORIZONTAL
BOT.	BOTTOM	LLV	LONG LEG VERTICAL
BPL	BASE PLATE	M	MOMENT
BRG	BEARING	MIRR.	MIRRORED
C	CHANNEL OR COMPRESSION	N.F.	NEAR FACE
c/c	CENTRE TO CENTRE	N.I.C.	NOT IN CONTRACT
CJ	CONTROL JOINT	N.T.S.	NOT TO SCALE
CONC.	CONCRETE	O.F.	OUTSIDE FACE
CONT.	CONTINUOUS	OPP.	OPPOSITE
c/w	COMPLETE WITH (INCLUDING)	P.C.	PRECAST CONCRETE OR PILECAP
D.L.	DEAD LOAD	PCO	PILE CUT-OFF
DIM.	DIMENSION	PL	PLATE
EA.	EACH	REINF.	REINFORCING
E.E	EACH END	REQ'D	REQUIRED
E.F.	EACH FACE	R.O.	ROUGH OPENING
E.J.	EXPANSION JOINT	SEC	SECTION
E.S.	EACH SIDE	S.O.G.	SLAB ON GRADE
EXP. JT	EXPANSION JOINT	STD	STANDARD
EX.	EXISTING	T	TOP OR TENSION FORCE
EXIST.	EXISTING	T/	TOP OF
E.W.	EACH WAY	T.O.	TOP OF
EL.	ELEVATION	TJ	TIE JOIST
EXT.	EXTERIOR	T.O.S.	TOP OF STEEL OR TOP OF SLAB
F	FORCE, AXIAL FORCE	T.O.W.	TOP OF WALL
F.F	FAR FACE	TYP.	TYPICAL
F.D.	FLOOR DRAIN	U.L.	UPPER LAYER
FDN	FOUNDATION	U/N	UNLESS NOTED
FTG	FOOTING	U/S	UNDERSIDE
FL.	FLOOR	V	VERTICAL OR SHEAR FORCE
GALV.	GALVANIZED	VERT.	VERTICAL
H	HORIZONTAL	V.O.S.	VERIFY ON SITE
HOR.	HORIZONTAL	WWM	WELDED WIRE MESH
I.F.	INSIDE FACE	@	AT (SPACING CENTRE TO CENTRE)
INT.	INTERIOR	Ø	DIAMETER
INCL.	INCLUDING		
L	LENGTH OR STEEL ANGLE		
Ld	REINFORCEMENT DEVELOPMENT LENGTH (TENSION UNLESS NOTED OTHERWISE)		

OTHER ABBREVIATIONS MAY BE USED IN CONTEXT - REQUEST CLARIFICATION IF UNSURE

SHOP DRAWINGS, SUBMITTALS AND DESIGN DETAILING

CRITERIA FOR SUPPLIERS:

GENERAL:
REPRODUCTIONS OF THE STRUCTURAL DRAWINGS SHALL NOT BE ACCEPTED AS SHOP DRAWINGS.

"PROFESSIONAL ENGINEER" IN THE FOLLOWING PARAGRAPHS AND THROUGHOUT THESE DRAWINGS MEANS A PROFESSIONAL ENGINEER REGISTERED IN AND LICENSED TO PRACTICE IN THE PROVINCE OF ONTARIO AND THE ENGINEER'S SEAL SHALL INCLUDE THEIR STAMP, THEIR SIGNATURE AND THE DATE OF SEALING.

REVIEW OF DRAWINGS APPLIES TO GENERAL ARRANGEMENT ONLY FOR THE PURPOSE OF ASCERTAINING CONFORMANCE WITH THE GENERAL DESIGN CONCEPT. THIS REVIEW DOES NOT IMPLY APPROVAL OF DETAIL DESIGN OR QUANTITIES IN SUBMITTED DRAWINGS, NOR DOES IT RELIEVE THE CONTRACTOR OF THEIR RESPONSIBILITY FOR MAKING THE WORK COMPLETE, ACCURATE AND IN ACCORDANCE WITH THE STRUCTURAL DRAWINGS. ALLOW 15 WORKING DAYS FOR SHOP DRAWING REVIEW.

DO NOT FABRICATE MATERIALS BASED ON REJECTED OR DISAPPROVED SHOP DRAWINGS.

DOCUMENT SUBMISSIONS SHALL INCLUDE FOR EACH DOCUMENT ELECTRONIC FILES IN PDF FORMAT DELIVERED BY EMAIL TO submittals@aar.ca, UNLESS OTHER FORMATS AND/OR METHODS OF DELIVERY ARE AGREED IN WRITING IN ADVANCE OF SUBMISSION.

PAPER DOCUMENTS SUBMITTED IN LIEU OF ELECTRONIC DOCUMENTS SHALL INCLUDE 2 COPIES AND 1 REPRODUCIBLE FOR EACH DOCUMENT.

FALSEWORK:

PROVIDE DETAILS OF DESIGN AND CONSTRUCTION OF FORMS AND FALSEWORK, SHORING AND RESHORING AND ANY SPECIAL REQUIREMENTS FOR STRIPPING OF FORMWORK. ALL SUCH DESIGN SHEETS SHALL BE PREPARED AND SEALED BY A PROFESSIONAL ENGINEER.

SUBMIT FOR REVIEW DRAWINGS OF ALL PROPOSED CONSTRUCTION JOINTS LOCATIONS, AND LAYOUT DRAWINGS OF CONCRETE ISOLATION, SLAB ON GRADE SAWCUTS, AND HOUSEKEEPING PADS.

CONCRETE - MATERIAL:

SUBMIT FOR REVIEW ALL PROPOSED CONCRETE MIX DESIGNS. SUBMIT AT LEAST 15 WORKING DAYS BEFORE START OF WORK.

CONCRETE - REINFORCING:

SUBMIT FOR REVIEW REINFORCEMENT PLACING DRAWINGS AND BAR LISTS FOR EVERY PORTION OF THE STRUCTURE. SHOW WALLS IN FULL ELEVATION. SHOW TOP STEEL AND BOTTOM STEEL FOR SLABS ON SEPARATE PLANS WITH REINFORCING STEEL CALLED UP DIRECTLY ON PLAN.

DIMENSIONS

CHECK DIMENSIONS ON THESE DRAWINGS AGAINST DIMENSIONS ON ARCHITECTURAL DRAWINGS BEFORE USING THEM FOR FABRICATION OR CONSTRUCTION. REPORT DISCREPANCIES IMMEDIATELY UPON DISCOVERY.

DRAWINGS HAVE BEEN MADE REASONABLY TO SCALE BUT CONTRACTOR MUST NOT SCALE THE DRAWINGS.

RECORD DRAWINGS

CONTRACTOR SHALL MAINTAIN TWO SETS OF RECORD DRAWINGS, SHOWING AS-BUILT CONDITIONS OF ALL ASPECTS OF THE STRUCTURE, AVAILABLE FOR REVIEW DURING CONSTRUCTION, AND FOR SUBMISSION TO THE CONSULTANT AND THE OWNER UPON PROJECT COMPLETION.

INSPECTIONS AND TESTING

THE FOLLOWING ITEMS SHALL BE INSPECTED OR TESTED BY INDEPENDENT INSPECTION/ TESTING AGENCIES DESIGNATED BY THE CLIENT. MATERIALS AND WORKMANSHIP NOT CONFORMING TO THE SPECIFICATIONS SHALL BE REJECTED BY THE CONTRACTOR. REPORTS AND TEST RESULTS SHALL BE PROMPTLY SUBMITTED TO THE ENGINEER FOR REVIEW. TESTING SHALL INCLUDE BUT NOT BE LIMITED TO:

SOILS:

ALL TESTING AND INSPECTIONS (COMPACTION, BEARING CAPACITY ETC.) AS PER THE REQUIREMENTS OF THE SOILS REPORT AND/OR GEOTECHNICAL ENGINEER.

SHORING:

ALL TESTING (e.g. PROOF TESTING OF TIE-BACKS) AS PER THE REQUIREMENTS OF THE SHORING ENGINEER AND/OR THE SPECIFICATIONS.

CONCRETE:

CONCRETE AND GROUT TESTING IN ACCORDANCE WITH CSA A23.2 LATEST EDITION AND THE SPECIFICATIONS, INCLUDING THE REQUIREMENTS OF SLUMP, AIR AND AGE BEFORE BEING USED. CONTRACTOR TO KEEP RECORDS OF POUR DATES, TESTING PERFORMED, CLASS OF CONCRETE USED WITH LOCATION AND TEST RESULTS FOR ALL ITEMS POURED.

TESTING TO DETERMINE THE IN-SITU STRENGTH OF CONCRETE FOR EARLY FORM REMOVAL PURPOSES WITH THE TYPE OF TEST BEING DETERMINED ON THE ADVICE OF THE TESTING AGENCY. TESTING AND REPAIRS NECESSARY TO THE STRUCTURE AS A RESULT OF THESE TESTS SHALL BE MADE BY THE CONTRACTOR AT NO EXPENSE TO THE OWNER.

TESTING AS REQUIRED AND SPECIFIED BY THE ENGINEER TO DETERMINE THE IN-SITU STRENGTH OF CONCRETE WHICH FAILS TO MEET THE SPECIFIED REQUIREMENTS OR WHICH, DUE TO APPEARANCE, DAMAGE OR DEFECTS MAY BE DEEMED REJECTABLE. CORES SHALL BE ACQUIRED AND TESTED BY THE DESIGNATED TESTING AGENCY BUT ANY REPAIRS NECESSARY TO THE STRUCTURE AS A RESULT OF THESE TESTS SHALL BE PERFORMED AT NO COST TO THE OWNER.

FOUNDATIONS

BEARING:
ALL FOUNDATIONS TO BEAR ON SOUND, UNDISTURBED, NATURAL SOIL.

DESIGN BEARING VALUES:
700 kPa AT ULS AND 75 kPa AT SLS UNLESS NOTED.

ALL BEARING SURFACES TO BE APPROVED BY GEOTECHNICAL CONSULTANT BEFORE POURING CONCRETE.

DO NOT BACKFILL AGAINST FOUNDATION WALLS UNTIL SUPPORTING SLABS HAVE BEEN POURED, UNLESS BRACING DETAILS ARE SUBMITTED. WHERE POSSIBLE BACKFILL BOTH SIDES OF WALLS SIMULTANEOUSLY.

FROST COVER:
BOTTOM OF FOOTINGS TO HAVE A MINIMUM 1830 mm COVER TO FINISHED EXTERIOR GRADE FOR FROST PROTECTION UNLESS NOTED. PROVIDE FROST PROTECTION FOR ALL FOOTINGS DURING WINTER CONSTRUCTION.

EXCAVATION SHORING

DESIGN SHALL BE BASED ON THE CRITERIA RECOMMENDED IN THE SOILS REPORT AND SHALL BE TO THE APPROVAL OF THE CITY OR THE OTHERWISE GOVERNING AUTHORITY.

WHERE REQUIRED, SHORING CONTRACTOR TO OBTAIN ALL NECESSARY APPROVALS FOR INSTALLATION OF TIE-BACK ANCHORS OUTSIDE THE INDICATED PROPERTY LINE. CONTRACTOR SHALL ESTABLISH THE LOCATION AND EXTENT OF UNDERGROUND UTILITY LINES WHERE INTERFERENCE WITH EXCAVATION/SHORING OPERATIONS ARE POSSIBLE TO OCCUR.

CONCRETE

ALL CONCRETE WORK TO BE IN ACCORDANCE WITH CSA-A23.1 AND CSA-A23.3 WITH THE FOLLOWING FURTHER PROVISIONS:

LOCATION	MIN. SPECIFIED 28 DAY CONC. STRENGTH	SLUMP	CLASS OF EXPOSURE	REMARKS
	MPa	mm		
BELOW GRADE FOOTINGS	35	80 ± 30	C-1	

NO ADDITIONAL WATER SHALL BE ADDED AT THE JOB SITE. CONCRETE WHICH HAS BEEN WATERED OR DOES NOT MEET SPECIFICATIONS SHALL BE REJECTED BY THE GENERAL CONTRACTOR.

CALCIUM CHLORIDE ADMIXTURES SHALL NOT BE USED.

REINFORCING STEEL

DETAIL AND PLACE REINFORCING STEEL IN ACCORDANCE WITH THE R.S.I.C. "REINFORCING STEEL MANUAL OF STANDARD PRACTICE" AND CSA-A23.1 UNLESS OTHERWISE NOTED.

REINFORCING BAR SHALL BE DEFORMED GRADE 400W AS PER CSA G30.18.

SPLICES:

ALL 1.3 Ld (TENSION) LAP U/N

LAPS FOR DOWELS TO MATCH THE LONGER REQUIREMENT OF THE ELEMENTS BEING CONNECTED.

REINFORCING CHAIRS:

PROVIDE CHAIRS, SPACER BARS, SUPPORT BARS AND OTHER ACCESSORIES TO SUPPORT REINFORCING IN ACCORDANCE WITH THE LATEST EDITIONS OF CSA A23.1 AND A23.3. CHAIRS TO BE PLASTIC, PLASTIC TIPPED OR CONCRETE. ALL TIE WIRE, CHAIRS AND BAR SUPPORTS USED FOR COATED REINFORCING SHALL BE NON-METALLIC OR PROTECTED WITH AN ACCEPTABLE COATING.

CHAIRS SHALL BE SPACED AT 1200 mm O.C. MAXIMUM. PROVIDE CONTINUOUS CHAIRS WHERE POSSIBLE.

CONCRETE COVER: (CLEAR TO REINFORCING)

U/S FOOTINGS (AGAINST SOIL)	75mm
U/S FOOTINGS (NOT AGAINST SOIL)	50mm
FOOTINGS (SIDES AND TOP)	50mm

1	2018/09/06	ISSUED FOR TENDER
B	2018/08/10	ISSUED FOR 99% REVIEW
A	2018/08/03	ISSUED FOR 66% REVIEW

No.	Date	Revision
-----	------	----------

Architect

Scale	By	Date	Checked
AS NOTED	J.M./C.A.	AUG. 2018	P.R.

Project
**BUILDING 82
RESTORATION**

Drawing
**GENERAL NOTES /
TYPICAL DETAILS**

Stamp 	Project No. CEF18 00174
Drawing No. S01	Revision

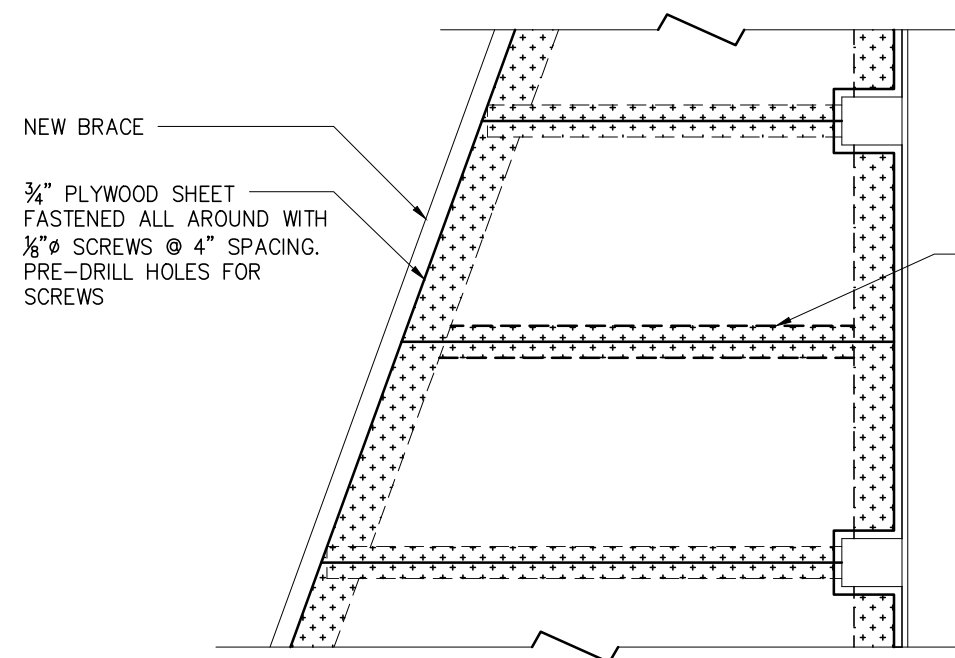

3
S03
DETAIL - TYP. PLYWOOD CONNECTION
1/2" = 1'-0"

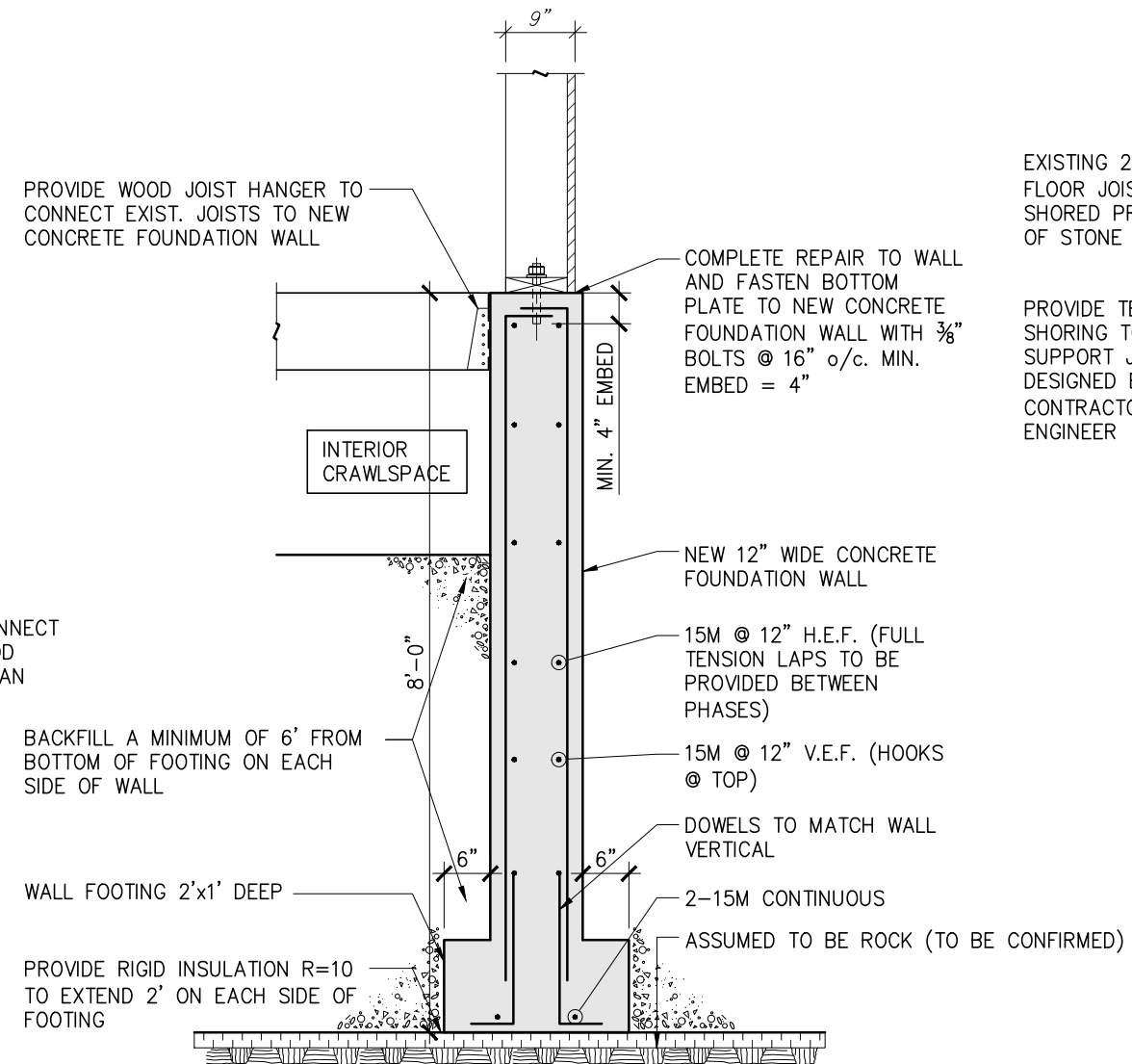

2
S02
SECTION - NEW FOUNDATION WALL WORK
1/2" = 1'-0"

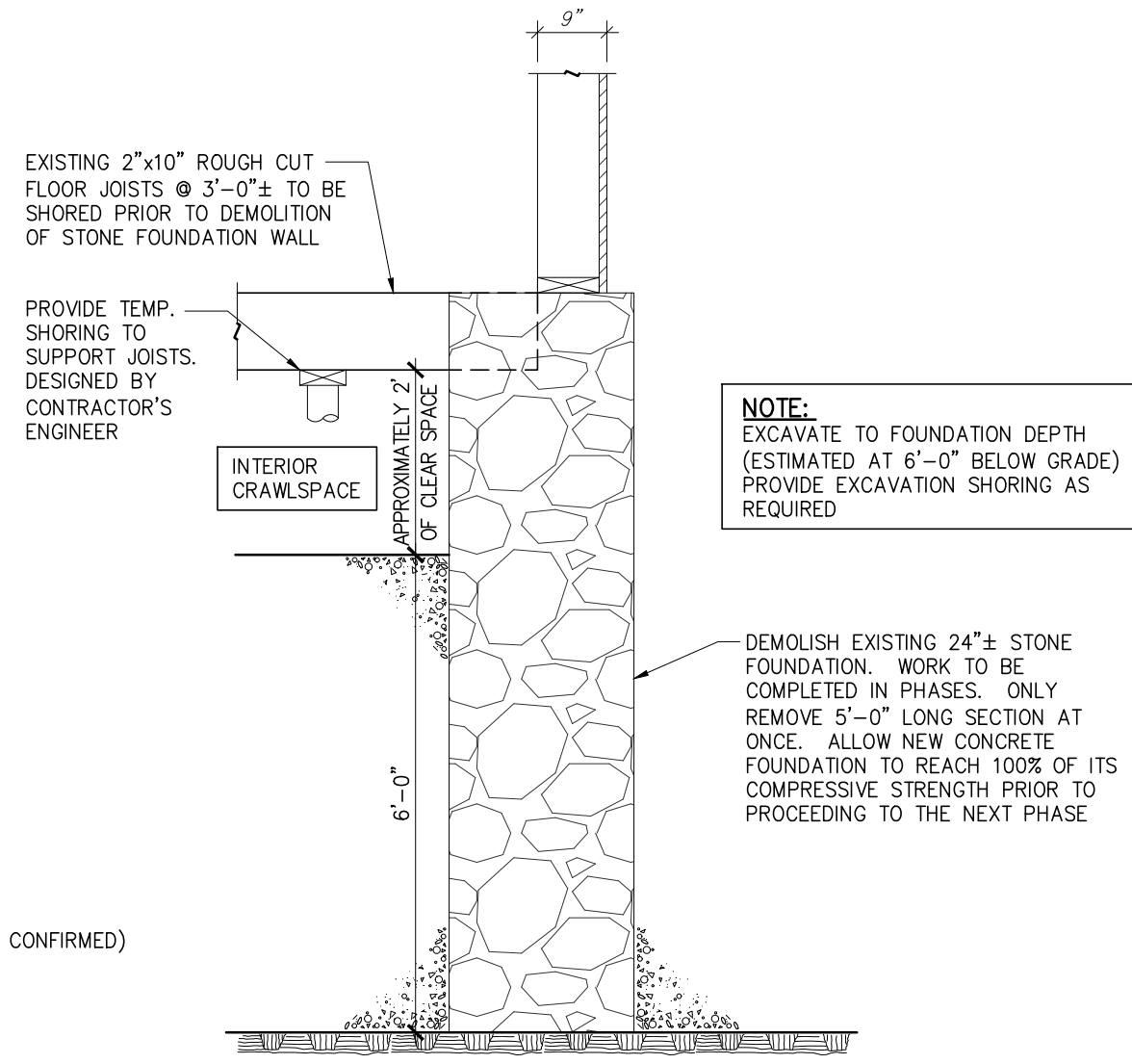

1
S02
SECTION - EXISTING FOUNDATION WALL DEMOLITION
1/2" = 1'-0"

NOTE:
EXCAVATE TO FOUNDATION DEPTH (ESTIMATED AT 6'-0" BELOW GRADE) PROVIDE EXCAVATION SHORING AS REQUIRED

DEMOLISH EXISTING 24"± STONE FOUNDATION. WORK TO BE COMPLETED IN PHASES. ONLY REMOVE 5'-0" LONG SECTION AT ONCE. ALLOW NEW CONCRETE FOUNDATION TO REACH 100% OF ITS COMPRESSIVE STRENGTH PRIOR TO PROCEEDING TO THE NEXT PHASE

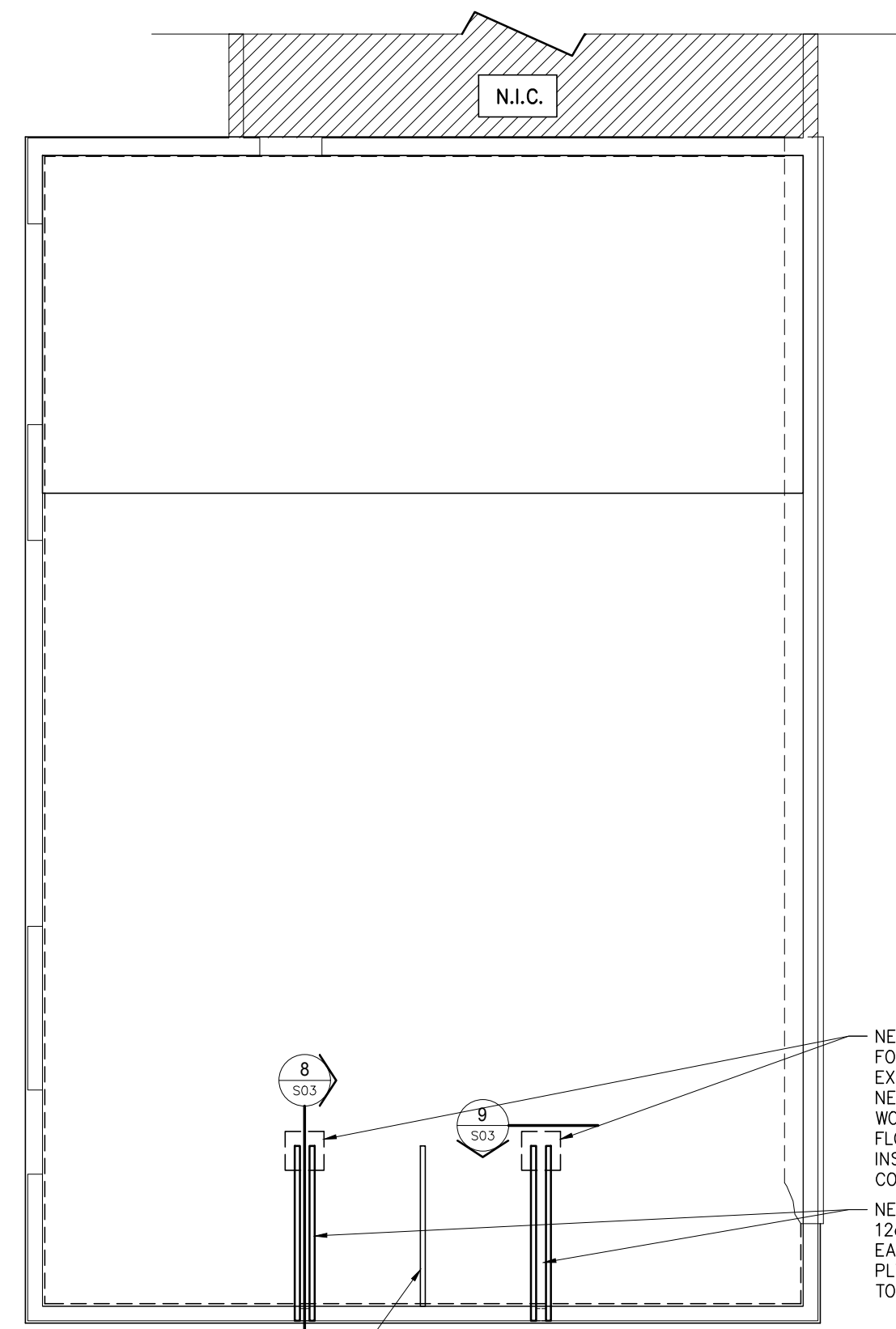

EXISTING PLAN - BRACING LAYOUT
1/8" = 1'-0"

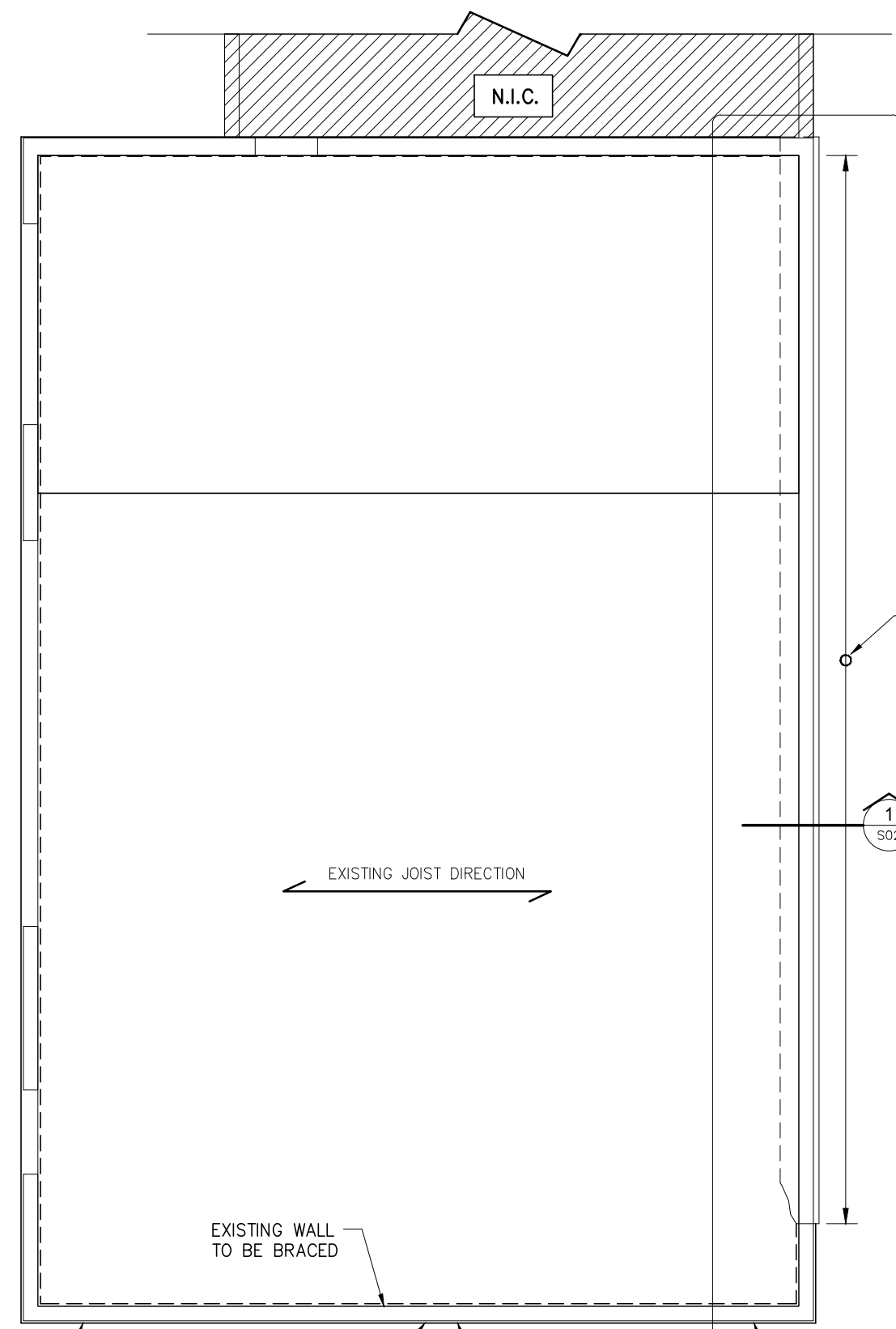

EXISTING PLAN - REPAIR AREAS
1/8" = 1'-0"

No.	Date	Revision
1	2018/09/06	ISSUED FOR TENDER
B	2018/08/10	ISSUED FOR 99% REVIEW
A	2018/08/03	ISSUED FOR 66% REVIEW

Architect

Scale	By	Date	Checked
AS NOTED	J.M./C.A.	AUG. 2018	P.R.

Project
BUILDING 82 RESTORATION

Drawing
GROUND FLOOR PLAN AND SECTIONS

Stamp

Project No.
CEF18 00174

Drawing No. **S02** Revision

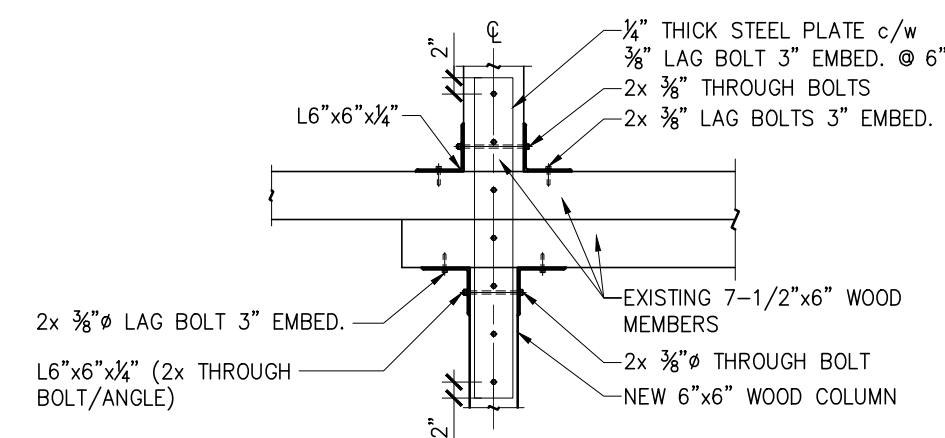

4 DETAIL - CONNECTION BETWEEN
S03 1/2" = 1'-0" EXIST. AND NEW COLUMN

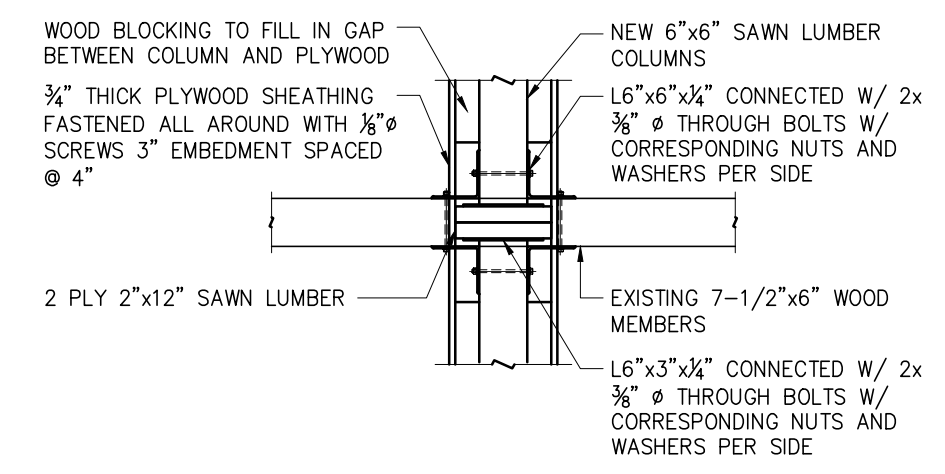

5 DETAIL - CONNECTION OF NEW 6x6
S03 1/2" = 1'-0" WOOD MEMBERS

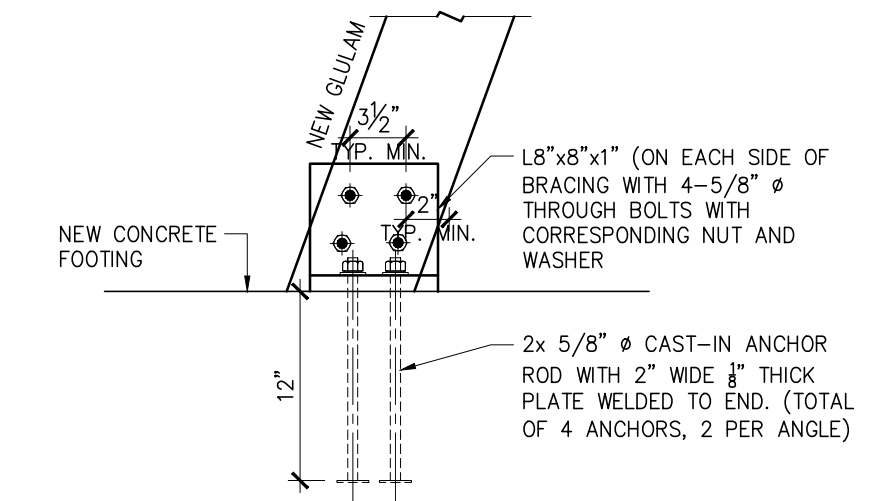

6 DETAIL - CONNECTION AT BRACE
S03 1" = 1'-0" AND FOOTING

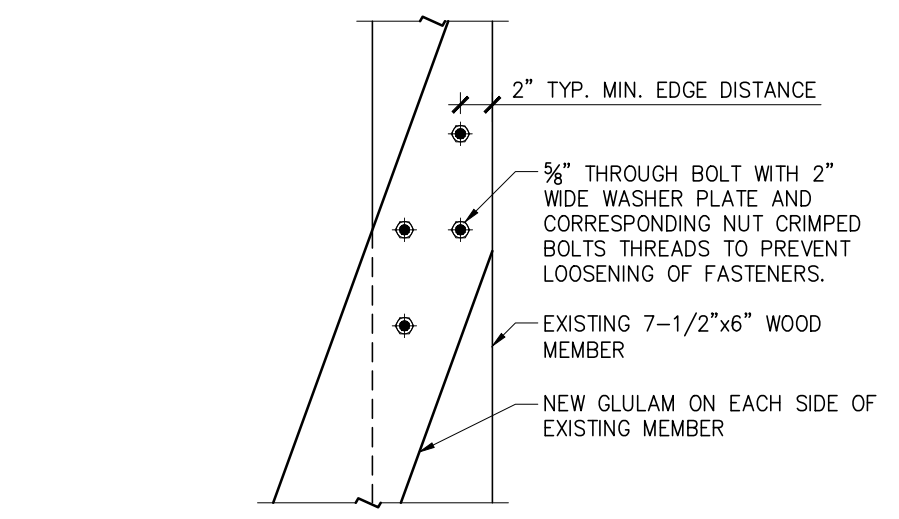

7 DETAIL - CONNECTION AT TOP
S03 1" = 1'-0" OF BRACE

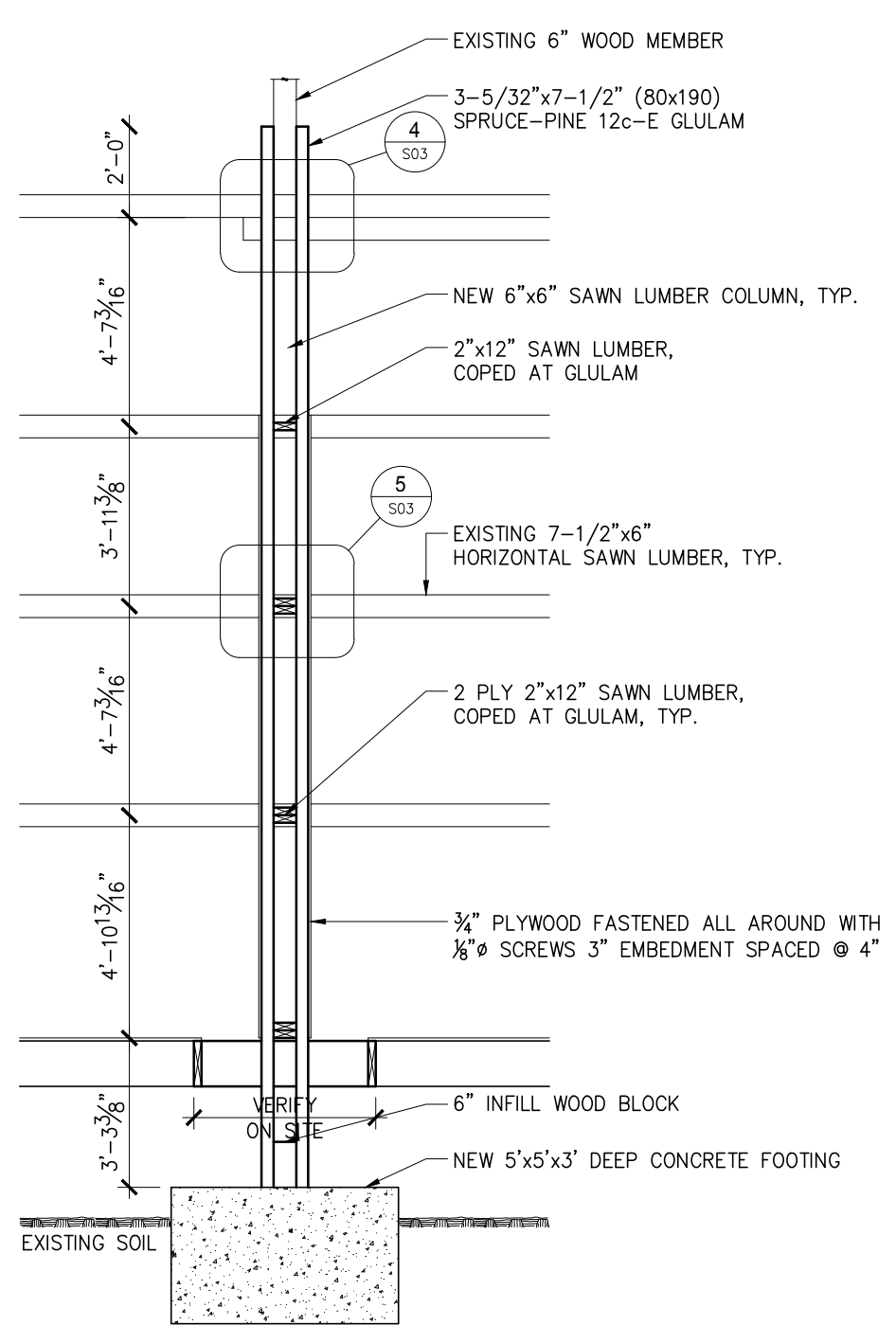

9 SECTION - FRONT ELEVATION VIEW
S02 1/4" = 1'-0"

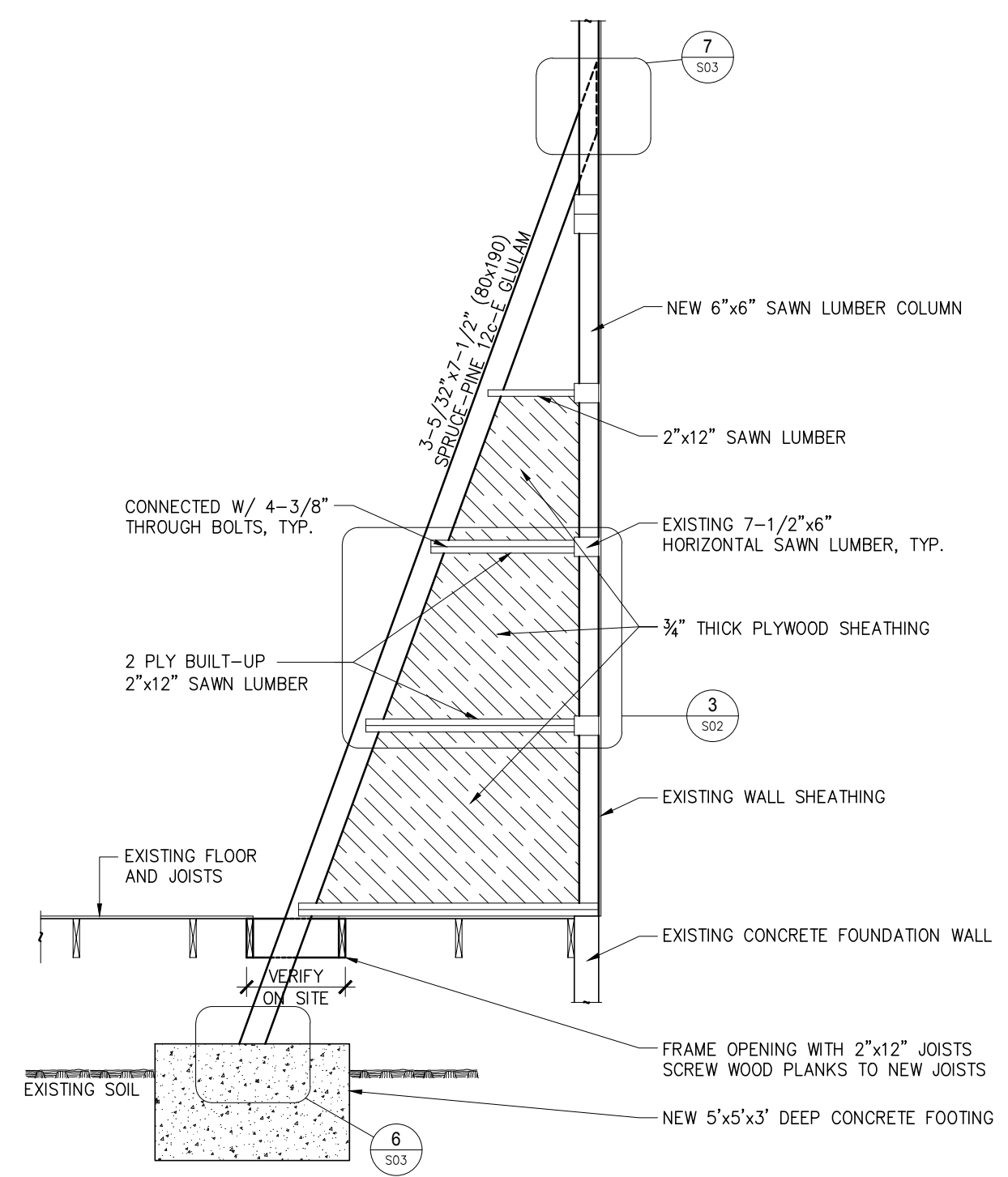

8 SECTION - THROUGH BRACE
S02 1/4" = 1'-0"

No.	Date	Revision
1	2018/09/06	ISSUED FOR TENDER
B	2018/08/10	ISSUED FOR 99% REVIEW
A	2018/08/03	ISSUED FOR 66% REVIEW

Scale	By	Date	Checked
AS NOTED	J.M./C.A.	AUG. 2018	P.R.

Project
BUILDING 82 RESTORATION

Drawing
SECTIONS AND DETAILS

Stamp 	Project No. CEF18 00174
Drawing No. S03	Revision