



Fisheries and Oceans
Canada

Pêches et Océans
Canada

Canadian
Coast Guard

Garde côtière
canadienne



SPECIFICATIONS

TOWER INSTALLATION

LL 123 LANCASTER FRONT RANGE (D50)

LAKE ST. FRANCIS

**LANCASTER, ON
(Vicinity CORNWALL, ON)**

File: FP802-180122

MARITIME AND CIVIL INFRASTRUCTURE



TABLE OF CONTENTS

SECTION:	011100 GENERAL INSTRUCTIONS	1
SECTION:	013300 SUBMITTAL PROCEDURES	8
SECTION:	013530 HEALTH AND SAFETY REQUIREMENTS	9
SECTION:	013543 ENVIRONMENTAL PROCEDURES	10
SECTION:	014500 QUALITY ASSURANCE AND CONTROL	13
SECTION:	016100 COMMON PRODUCT REQUIREMENTS	15
SECTION:	024116 DEMOLITION	17
SECTION:	033000 CONCRETE WORK	19
SECTION:	133613 METAL TOWERS	23
SECTION:	310099 FOUNDATIONS	25

APPENDICES

- APPENDIX B1 – SITE LOCATION AND PHOTOGRAPHS
- APPENDIX B2 – SUMMARY OF CONTRACT SUBMITTALS
- APPENDIX B3 – DRAWINGS
- APPENDIX B4 – GEOTECHNICAL INFORMATION
- APPENDIX B5 – MARINE ACCESS REQUIREMENTS
- APPENDIX B6 – CCG ROTARY WING SUPPORT



SECTION: 011100 GENERAL INSTRUCTIONS

PART 1 - GENERAL

1.1 Minimum Standards

- .1 Perform work in accordance with National Building Code of Canada (NBC) and any other code of provincial or local application. In the case of any conflict or discrepancy, the more stringent requirements shall apply.
 - .1 Meet or exceed requirements of:
 - .1 Contract documents;
 - .2 Specified standards, codes and referenced documents.

1.2 Definitions

- .1 The following acronyms utilized throughout these specifications are to be interpreted as follows:
 - .1 CCG: Canadian Coast Guard
 - .2 DFO: Department of Fisheries and Oceans
 - .3 PA: Project Authority/Technical Authority
 - .4 CA: Contract Authority
 - .5 ATON: Aid to Navigation
 - .6 SRAN: Short Range Aid to Navigation
 - .1 Term encompassing the daymark, marine lantern, solar panel, batteries and all related appurtenances
 - .7 DSL: Designated Staging Location

1.3 Background

- .1 CCG requires the installation of a new ATON tower at the site known as LL123 – Lancaster Front Range (D50) to ensure that all necessary SRAN equipment can be safely accessed and maintained. Existing tower has historical significance and is to be maintained in its present condition. Intent is to construct the new tower in the area currently occupied by the concrete helipad which is surplus to CCG requirements. The new tower has been fabricated by others in anticipation of construction and will be provided to the Contractor at the CCG DSL.



1.4 Description of Work

- .1 Work under this Contract includes, but is not limited to, the provision of all labour, materials, and equipment required to:
 - .1 Mobilize to the site;
 - .2 Design and construct a foundation of suitable structural capacity to support the intended loads of the ATON;
 - .1 Bidders are instructed to assume the installation of a reinforced concrete foundation as detailed in Appendix B3, Contract Drawings.
 - .2 Geotechnical investigation has been completed at this location and borehole log is presented in Appendix B4, Geotechnical Information.
 - .3 Transport the ATON from the CCG DSL to the site; and,
 - .4 Install the ATON upon the completed foundation.
- .2 The following works are to be undertaken by others and are hereby excluded from the work of this contract.
 - .1 Fabrication of the new tower;
 - .2 Application of marine coating system;
 - .3 Supply and installation of all SRAN equipment; and,
 - .4 Removal of the existing ATON.

1.5 Submittals

- .1 Mandatory deliverables and the related deadlines for submission are detailed below and in Appendix B2. The following identifies general requirements only. The relevant sections must be consulted for a complete listing of mandatory content.
- .2 Detailed Schedule:
 - .1 Deadline:
 - .1 No later than ten (10) working days following award.
 - .2 Deliverables:
 - .1 The Contractor shall furnish a high level schedule outlining:
 - .1 Anticipated start and finish dates of the project.
 - .2 Proposed submission dates for:



- .1 Preliminary design package; and,
- .2 Construction plan.
- .3 Anticipated onsite periods (preliminary investigations, material staging, construction).
- .3 The schedule is to be updated and revised as necessary throughout the duration of the project upon reasonable request of the CCG PA.
- .3 Project participant listing:
 - .1 Deadline: With detailed schedule.
 - .2 Deliverables: Contractor to identify the following:
 - .1 Project Manager,
 - .2 Project Engineer (responsible for foundation design), and,
 - .3 Pertinent subcontractors, specifically:
 - .1 Any firm providing marine access to the site.
- .4 Design Package
 - .1 Deadline: As identified in Contractor's schedule.
 - .2 Deliverables: Foundation design (Section 310099).
- .5 Construction Plan:
 - .1 Deadline:
 - .1 As identified in the Contractor's schedule.
 - .2 No less than ten [10] working days prior to mobilization.
 - .2 Deliverables:
 - .1 A written plan of sufficient detail to demonstrate that the Contractor has considered all the challenges of the project and is prepared to undertake the works in a competent and professional manner in accordance with all legislation, including:
 - .1 Project specific safety program (Section 013530);
 - .2 Project environmental protection plan (Section 013543);
 - .3 Concrete placement plan, if required (Section 033000);
 - .4 Foundation installation package (Section 310099).



.6 Maintenance Package

.1 Deadline:

.1 No more than 30 calendar days following substantial completion of the installation.

.2 Deliverables:

.1 Consolidated as-constructed/as-built documentation. Package is to include; but, is not necessarily limited to the following:

.1 Concrete test results (Section 033000); and,

.2 Foundation and anchorage maintenance package (Section 310099).

1.6 Contractor Qualifications

.1 The work shall be carried out under the supervision and responsibility of a sole specialized Contractor with experience in the installation of similar facilities.

.2 The Project Engineer must be licensed to practice the required discipline within the Province of Ontario.

.3 Subcontractors engaged by the Contractor must possess all necessary licenses and certifications necessary to practice their trade within the Province of Ontario.

1.7 Site Location

.1 The location of the site is as follows:

LL #	Name	Latitude	Longitude
123	Lancaster Range Front(D50)	45° 6'1.18"N	74°29'28.19"W

.2 Site is located offshore of the village of Lancaster, ON in Lake St. Francis. The nearest major city is Cornwall, ON.

1.8 Existing Conditions

.1 Bidders must make their own estimate of the difficulties associated with all phases of the works.

.2 The Contractor must include in their costs, all expenses related to the difficulties of working at the site.

.3 Photographs of the existing site are included in Appendix B1.



1.9 Contractor's Access to Site

- .1 Contractor is responsible for transportation of all labour, materials, and equipment to and from the site.
- .2 Access to the site is offshore. Anticipated mobilization point is Lancaster, ON.
- .3 Access is anticipated to be completed by appropriate vessel /floating barge.
 - .1 CCG requirements for marine access are listed in Appendix B4.

1.10 Canadian Coast Guard Access to the Site.

- .1 The Contractor must allow in their price for the proper transportation to and from the site of the CCG PA and/or designated representatives.
 - .1 Transportation is to be from Lancaster, ON unless otherwise agreed upon between the Contractor and the CCG PA.
 - .1 PPE for CCG PA (/ representatives) is the responsibility of CCG. PPE provided will be in accordance with more stringent requirements of either the Contractor's or CCG's designated safety equipment.
 - .2 Contractor must estimate that such services will be required throughout the field work phase while the Contractor is undertaking work at the Project Site.
 - .1 Total number of passengers will be one (1) on average; but, may increase to two or three (2-3) depending on quality assurance requirements itemized herein.

1.11 Designated Staging Location

- .1 Items identified as supplied by, or, salvaged to Coast Guard shall be collected or delivered by the Contractor to the following staging location, unless alternate arrangements have been made.
 - .1 Staging location: CCG Base – Prescott, 401 King St W, Prescott, ON K0E 1T0.
 - .2 Advise MCI at least three (3) working days prior to pick-up/delivery.
 - .1 Shipping/Receiving hours: Monday through Friday, 9:00AM to 3:00PM.
- .2 The Contractor shall be responsible for all transportation costs between the project site and the identified staging area.

1.12 Canadian Coast Guard Helicopter Support

- .1 Upon the request of the Contractor, CCG PA will coordinate the support of CCGs rotary wing assets.
- .2 Use of CCGs rotary wing assets will be subject to **FULL COST RECOVERY** from any amount payable under the Contract. Such costs include; but, are not necessarily limited to: all flying time (inclusive of ferry time to contractor's staging area), fuel consumption, and crew per diem.



- .3 Use of CCG's helicopter assets is not **MANDATORY**. Use of such assets is at the Contractor's discretion. The Contractor's bid must include their estimate of charges intend to be incurred in the use of such assets.
 - .1 Charge out rates, fuel consumption estimates, and airframe capacities are indicated in Appendix B6.
 - .1 Bidders may consult the use case provided as a baseline to establish an appropriate estimate.
- .4 Coordination of CCG's rotary wing assets will be completed through CCG PA only.
- .5 Helicopter support is subject to equipment capability (as determined by PIC), the availability of either airframe, and weather.

1.13 Completion, Scheduling and Planning of the Works

- .1 Work may commence as early as practical following CCGs acceptance and approval of mandatory submissions.
- .2 However, bidders are instructed to assume that the new ATON tower will not be available for pick up at the DSL prior to 28 SEP 18.
- .3 Work shall be completed no later than 30 NOV 18 unless otherwise negotiated and approved in writing by CCG PA and DFO CA.

1.14 Temporary Facilities

- .1 Arrange, pay for, and maintain temporary electrical power supply as required for construction, and water supply as required, in accordance with governing regulations and ordinances.
- .2 Maintain emergency spills kit on-site at all times.

1.15 Fees, Permits, Certificates and Information

- .1 Contractor shall provide authorities having jurisdiction with all information requested.
 - .1 Contractor shall provide copies to CCG of any documentation submitted to other authorities related to the work described in this document.
- .2 Contractor shall pay fees and obtain certificates and permits required.
- .3 Contractor shall furnish certificates and permits when requested.

1.16 Reference Documents

- .1 The most recent publication or edition of any document referenced in this specification should be used unless stated otherwise.



Fisheries and Oceans
Canada

Pêches et Océans
Canada

Canadian
Coast Guard

Garde côtière
canadienne



1.17 Required Submissions

- .1 A summary of the minimum mandatory submissions required can be found in Appendix B2. This summary is not an exhaustive list of all submissions required for the duration of the project. Additional submissions may be required after award.

PART 2 - PRODUCTS

- 2.1 Not Used

PART 3 - EXECUTION

- 3.1 Not Used



SECTION: 013300 SUBMITTAL PROCEDURES

PART 1 - GENERAL

1.1 General

- .1 This section specifies general requirements and procedures for the Contractor's submissions of documents to CCG PA for review.
- .2 Do not proceed with the work until submitted documents or samples have been reviewed by CCG PA.
- .3 Where items or information is not produced in SI Metric units, converted values are acceptable.
- .4 Contractor's responsibility for errors and omissions in submission is not relieved by CCG PA's review of the submitted documents.
- .5 Notify CCG PA, in writing at time of submission, identifying deviations from requirements of Contract Documents stating reasons for deviations.
- .6 Contractor's responsibility for deviations in submission from requirements of Contract Documents is not relieved by CCG PA's review of submission, unless CCG PA gives written acceptance of specific deviations.
- .7 Make any changes to submissions that CCG PA may require consistent with Contract Documents and resubmit as directed by CCG PA.
- .8 Provide CCG PA with a written notice, when resubmitting, of any revisions other than those requested CCG PA.

1.2 Submission Requirements

- .1 Coordinate each submission with requirements of work and Contract Documents. Individual submissions will not be reviewed until all related information is available.
- .2 Allow at least three (3) working days, or as stipulated elsewhere in these specifications, for CCG PA to review the submission.



SECTION: 013530 HEALTH AND SAFETY REQUIREMENTS

PART 1 - GENERAL

1.1 Scope

- .1 The Contractor shall be responsible to develop, implement and enforce a safety program which addresses all elements of the work performed at the project location.

1.2 References

- .1 Work under this section shall be undertaken in strict conformance with all listed references, In the case of any conflict or discrepancy the more stringent requirements shall apply.
 - .1 Canada Labour Code Part II
 - .2 NRC-CNRC National Building Code of Canada
 - .3 Ontario Occupational Health and Safety Act and Regulations
 - .4 Any and all other Provincial/Territorial Regulations and Policies; Worker's Compensation Board Policies; Local municipal regulations; pertaining to safety of the Contractors workers

1.3 Submittals

- .1 Project Specific Safety Program
 - .1 Deadline: With Construction Plan.
 - .2 Deliverables: Safety Program Document, include:
 - .1 A listing of all activities specific to this phase of the project and their Health & Safety risks or hazards.
 - .2 Detailed descriptions of how the activities are to be carried out as well as methods for mitigating hazards and risks.
 - .3 A listing of personnel responsible for health and safety measures, and Emergency procedures.
 - .4 Material Safety Data Sheets for hazardous products to be utilized in the execution of the works.



SECTION: 013543 ENVIRONMENTAL PROCEDURES

PART 1 - GENERAL

1.1 Scope of Work

- .1 The Contractor must implement and enforce the following procedures throughout the duration of the work completed at the project location to mitigate potential negative impacts on the surrounding environment.

1.2 References

- .1 Work under this section shall be undertaken in strict conformance with all listed references, In the case of any conflict or discrepancy the more stringent requirements shall apply.
 - .1 Canadian Environmental Protection Act

1.3 Submittals

- .1 Contractor shall submit an Environmental Protection Plan.
 - .1 Deadline: With Construction Plan.
 - .2 Deliverables: Submit a plan addressing procedures to be implemented to mitigate any negative impact on the environment. Detail:
 - .1 Equipment features (age, spill containment);
 - .2 Staging, refueling, and cleaning areas;
 - .3 Clean-up and/or containment procedures (including concrete/grout);
 - .4 Waste disposal methods and sites; and,
 - .5 Sedimentation control measures.

PART 2 - PRODUCTS

1.2 General

- .1 Avoid use of hazardous products. Use environmentally friendly products where practical.

PART 3 - EXECUTION

1.1 Construction Area

- .1 Confine construction activities to as small an area as practical.



- .2 Establish material storage, cleaning, and refueling areas where impacts to the surrounding environment will be negligible or readily mitigated.

3.2 Stockpiling of materials

- .1 Materials must be stockpiled as far from the shoreline as practical. Tarps must be used to control dust and run-off.
- .2 Stockpiled excavated materials shall be skirted using filter fabric to control run-off of fines during rain.

3.3 Disposal of Wastes

- .1 Clean-up the site at the end of each working day.
- .2 All waste material to be disposed of in a legal manner at a site approved by local authorities. Transporter/hauler must be appropriately licensed.
 - .1 Recycle or reuse materials where possible.
- .3 Fires and burning of rubbish on site not permitted.
- .4 Do not bury rubbish and waste materials on site.

3.4 Clearing and Grubbing

- .1 Only clear vegetation that interferes with construction.

3.5 Drainage

- .1 Provide temporary drainage and pumping as necessary to keep excavations and site free from water.
 - .1 Suspend works during periods of heavy rainfall and add temporary covers to discourage run-off.
 - .2 Water pumped from excavation shall be adequately treated to ensure that water returning to the watercourse contains minimal fines. Procedures anticipated for preventing the pumping of fines shall be identified in the environmental protection plan, and may include the following:
 - .1 The use of filter bags;
 - .2 Straw bale check dams or silt fence;
 - .3 The means for controlling silt run-off shall be dependent on the site and the quantity of water pumped, and shall be to the discretion of the CCG site staff.
 - .4 Sediment control measures shall be inspected and improved/cleaned/replaced as necessary.



3.6 Pollution Control

- .1 Provide methods, means, and facilities to prevent the contamination of soil, water, and atmosphere from the discharge of pollutants produced by construction operations.
- .2 Vehicles, machinery, and equipment shall be in good repair, equipped with emission controls as applicable and operated within regulatory requirements.
- .3 Abide by local noise by-laws.
- .4 Avoid unnecessary idling of vehicles or heavy machinery.
- .5 Limit use of equipment around the shoreline where possible.
- .6 Implement and maintain dust and particulate control measures in accordance with provincial requirements:
 - .1 All bulk material haul equipment shall be appropriately tarped. Watertight vehicles shall be used to haul wet materials
- .7 Designate a cleaning area for tools to limit water use and runoff. Do not allow deleterious materials to enter waterways. Ensure emptied containers are sealed and stored safely for disposal.
- .8 The Contractor shall take all necessary precautions to guard against the release of any noxious substance or pollutant to the environment. In the event of any spill the Contractor shall take immediate action to contain the release and mitigate any impact.
 - .1 Materials and equipment to intercept, contain, and clean-up any spill or other release shall be maintained on site throughout the construction period and must be readily accessible at all times.
 - .2 Any uncontrolled release of a known contaminant (spills, fire/smoke) shall be reported to appropriate Provincial Authority and CCG. Spills of deleterious substances to be immediately contained and cleaned up in accordance with provincial regulatory requirements.
 - .3 Provincial Authority: Ontario Spills Action Centre 1-800-1-800-265-0237
- .9 Traffic
 - .1 Minimize soil compaction by driving, parking vehicles, and walking, etc. on existing paved roadways/laneways. If soil is impacted by compaction, compensate by restoring areas with new soil, as required.



SECTION: 014500 QUALITY ASSURANCE AND CONTROL

PART 1 - GENERAL

1.1 Inspection

- .1 CCG PA or their representative shall have access to the work at all times. If parts of the work are prepared off-site or in a shop, access shall be given to such work throughout the duration of the project.
- .2 In the event the work must be submitted to special testing, inspection or approvals prescribed by these specifications or provided for in work-site regulations, the request for inspection must be made without unreasonable delay.

1.2 Procedures

- .1 Provide CCG PA with advance notice whenever testing is required in accordance with these specifications, so that all parties involved can be present.
- .2 Provide necessary manpower and installations for obtaining and handling samples and material on site.
- .3 Provide access to site if the site is of remote nature whereby the Contractor is responsible for providing access to the site

1.3 Rejected Work

- .1 Remove defective work, whether incorporated into the work or not, which has been rejected by CCG PA as failing to comply with the contract documents. Replace or re-execute in accordance with the Contract Documents.

1.4 Tests and Mixture Formulas

- .1 Supply test reports and required mixture formulas.

1.5 Factory Tests

- .1 Submit test certificates as prescribed in the relevant section of the specifications.

1.6 Acceptance of Work

- .1 CCG PA will make acceptance visits of work executed by the Contractor at the critical milestones identified in the following sections.
- .2 The Contractor is to inform CCG PA at least three (3) working days before achieving these milestones to allow time for inspection to be coordinated.



Fisheries and Oceans
Canada

Pêches et Océans
Canada

Canadian
Coast Guard

Garde côtière
canadienne



- .3 All work shall be completed in compliance with these specifications before requesting inspection. If the work is not completed or deemed non-compliant, the Contractor shall be responsible for all costs incurred for subsequent inspections.



SECTION: 016100 COMMON PRODUCT REQUIREMENTS

PART 1 - GENERAL

1.1 General

- .1 Secure CCG PA's approval of all products to be incorporated into the works. Work shall not commence until product data and/or samples have received written approval.
- .2 Supply and/or fabricate material and equipment of prescribed quality, with performance conforming to these specifications, references and industry standards.
- .3 Use new material and equipment unless otherwise specified.
- .4 Ensure replacements parts may be readily procured.
- .5 Use products from one manufacturer for material and equipment of same type or classification, unless otherwise specified.

1.2 Manufacturer's Instructions

- .1 Unless otherwise specified, comply with manufacturer's latest printed instructions for materials and installation methods.
- .2 Notify CCG PA in writing of any conflict between these specifications and manufacturer's instructions; CCG PA will designate which document is to be followed.

1.3 Compliance

- .1 When material or equipment is specified by standard or performance specifications, upon request of CCG PA, obtain an independent testing laboratory report from the manufacturer, stating that material or equipment meets or exceeds specified requirements.

1.4 Substitution

- .1 Where specific products have been specified, proposals for substitution may only be submitted after award of contract. Such requests must include statements of respective costs of items originally specified and the proposed substitution.
- .2 No substitutions will be permitted without prior written approval of CCG PA. Substitutions will be considered by CCG PA only when:
 - .1 Materials specified in Contract Documents are not available; or,
 - .2 Delivery date of materials selected from those materials specified would unduly delay completion of contract; or,
 - .3 Alternative materials to those specified which are brought to the attention of, and are considered by CCG PA as equivalent to the material specified. Where the value of such



Fisheries and Oceans
Canada

Pêches et Océans
Canada

Canadian
Coast Guard

Garde côtière
canadienne



material is less than the material specified the difference is to be credited from the Contract amount.

- .3 Should the proposed substitution be accepted either in whole or in part, the Contractor must assume full responsibility and costs when such substitution affects other work on the project including any and all design or drawing changes required as a result of substitution.

1.5 Submittals

- .1 Provide product specifications and/or samples upon request from CCG PA.



SECTION: 024116 DEMOLITION

PART 1 - GENERAL

1.1 Scope of Work

- .1 Demolition is not anticipated to be required. This section is included for the purposes of making Bidder's and the successful Contractor aware of CCG requirements in the event that demolition works are deemed necessary upon the completion of the Contractor's geotechnical investigation.

1.2 References

- .1 Work under this section shall be undertaken in strict conformance with all listed references, In the case of any conflict or discrepancy the more stringent requirements shall apply.
 - .1 Canada Labour Code Part II
 - .2 NRC-CNRC National Building Code of Canada
 - .3 Ontario Occupational Health and Safety Act and Regulations
 - .4 CSA S350-[M1980(R1998)], Code of Practice for Safety in Demolition of Structures

1.3 Existing Conditions

- .1 Existing facilities are as noted in Appendix B1.
- .2 The existing ATON tower is not to be damaged. All damage to the existing structure will be remedied by the Contractor, at their expense, to the satisfaction of the CCG PA.

1.4 Submittals

- .1 Waste disposal receipts
 - .1 Deadline: With Maintenance Package
 - .2 Deliverables: Provide documentation pertaining to the final disposal location and method of the existing marine cable haul out system.



PART 2 - PRODUCTS

- 1.1 Not used.

PART 3 - EXECUTION

1.1 Preparation

- .1 Erect warning signs and barricades.
- .2 Ensure all environmental protection/mitigation measures are in place.
- .3 Ensure all items identified for salvage have been removed and stored.

3.2 Demolition

- .1 Demolish existing facilities to the limits specified in the foundation design drawings.
- .2 Existing concrete foundation is to be demolished only as necessary to facilitate installation and performance of the new foundation.
- .3 Ensure that demolition does not adversely affect adjacent watercourses, groundwater and wildlife, or contribute to excess air and noise pollution.

3.3 Disposal

- .1 All material is to be disposed of off-site and a licensed disposal/recycling facility.



SECTION: 033000 CONCRETE WORK

PART 1 - GENERAL

1.1 Scope of Work

- .1 Work of this section includes the supply of all labour, material, and equipment, necessary to complete the:
 - .1 Installation of reinforced concrete features stipulated in the Contractor's approved foundation design.
 - .2 Supply, install and maintain any and all measures to ensure that curing is adequate for adequate strength development, durability, and impermeability.

1.2 Related sections

- .1 Section 310099 Foundations. Section stipulates design requirements.

1.3 References

- .1 Work under this section shall be undertaken in strict conformance with all listed references, In the case of any conflict or discrepancy the more stringent requirements shall apply.
 - .1 Canada Labour Code Part II
 - .2 NRC-CNRC National Building Code of Canada
 - .3 Ontario Occupational Health and Safety Act and Regulations
 - .4 CAN/CSA-A23.1 Concrete Materials and Methods of Concrete Construction
 - .5 CAN/CSA A23.2 Methods of Test and Standard Practices for Concrete
 - .6 CAN/CSA A23.3 Design of Concrete Structures
 - .7 CAN/CSA-G30.18 Billet Steel Bars for Concrete Reinforcement
 - .8 CAN/CSA S269.3 Concrete Formwork
 - .9 ACI Specification 306 Cold Weather Concreting (if relevant)

1.4 Submittals

- .1 The following submittals are to be provided to the CCG PA:
 - .1 Concrete Placement Plan:
 - .1 Deadline: Furnish with Construction Plan (Section 011100)



.2 Deliverables: Provide a high level summary of:

.1 Mix properties and admixtures;

.1 Demonstrate compliance with CCG Criteria and completed foundation design;

.2 identify the location of the source of ready mix concrete, the haul route; and , any other relevant information required to demonstrate a plan for getting the concrete into the forms in the required amount of time;

.3 Finishing procedures;

.4 Curing methods and schedule;

.5 Clean-up procedures; and,

.6 Mitigation measures to account for hot or cold temperatures where reasonably anticipated during the construction period.

.2 Concrete test results

.1 Air, Slump and associated plastic properties.

.1 Deadline: as soon as practical upon completion of testing

.2 Deliverables: Technicians field report

.2 Strength,

.1 Deadline: with Maintenance Package (Section 011100).

.2 Deliverables: results of all concrete testing undertaken by the Contractor.

1.5 Quality Assurance

.1 CCG's minimum inspection requirements are detailed below. The Contractor shall be responsible to notify CCG of the date and time that the works may be inspected.

.1 Upon completion of formwork and placement of reinforcement.

.2 During execution of concrete placement.

.2 The Contractor shall be responsible to arrange for concrete testing on site the day of the pour. This shall include at minimum a test for slump, air entrainment and strength (3 cylinders, one [1] 7 day, and two [2] 28 day).

.1 Testing is to be completed by a third party independent Consultant and is to be completed by a certified technician in accordance with CSA Code A23.2. Test results are to be provided to both CCG and the Contractor.



PART 2 - MATERIALS

2.1 General

- .1 All materials shall conform to requirements of CAN/CSA-A23.1.

2.2 Concrete

- .1 Concrete supplier shall be a holder of valid "Certificate of Ready Mixed/Mobile Mix Concrete Production Facilities" as issued by the 'Ready Mixed Concrete Association of Ontario' (RMCAO)/Concrete Ontario.
- .2 Concrete performance criteria must be as determined by Contractor and indicated on their approved engineering plans/drawings.

2.3 Reinforcement

- .1 Shall be as specified by the Contractor's Engineer.
- .2 Reinforcement is to conform to the requirements of CAN/CSA-A23

PART 3 - EXECUTION

3.1 General

- .1 Concrete must be placed, finished, and cured in accordance with the Contractor's submitted construction plan and the Contractor's engineered drawings.

3.2 Preparation

- .1 Remove all loose and deleterious material.
- .2 Construct forms and reinforcement in accordance with the Engineer's specifications.
- .3 All exposed edges are to be chamfered.

3.3 Placement

- .1 Concrete placement shall not commence until formwork and reinforcement have been inspected by CCG.
- .2 Contractor shall place finish and cure concrete as per CAN CSA A23.1 making all adjustments necessary to account for climatic conditions anticipated during the curing period.
- .3 Concrete shall be placed in one continuous pour unless alternative arrangements specified by the Contractor's Engineer.
- .4 The development of cold joints shall be avoided.



Fisheries and Oceans
Canada

Pêches et Océans
Canada

Canadian
Coast Guard

Garde côtière
canadienne



- .5 Exposed concrete surfaces are to be finished to provide a lightly brushed non-skid surface, unless otherwise specified.
- .6 Cut control joints as specified.
- .7 Concrete shall be finished so as to slope gently away from the center of the slab. No water shall pond on the finished surface.

3.4 Curing

- .1 Curing must be undertaken in accordance with CAN CSA A23.1 and the Contractor's approved Construction Plan.
 - .1 Curing regiment employed must take into account local climatic conditions reasonably anticipated to occur during the curing period.



SECTION: 133613 METAL TOWERS

PART 1 - GENERAL

1.1 Scope of Work

- .1 Work under this section includes the supply of all labour, material, and equipment required to:
 - .1 Collect the new ATON at CCG DSL and transport same to the project site.
 - .2 Install the new ATON upon the completed foundation.
- .2 Tower and lantern will be provided by CCG and Contractor is to collect same from the CCG designated staging location.

1.2 References

- .1 Work under this section shall be undertaken in strict conformance with all listed references. In the case of any conflict or discrepancy the more stringent requirements shall apply.
 - .1 Canada Labour Code Part II
 - .2 NRC-CNRC National Building Code of Canada

1.3 Submittals

- .1 The following submittals are to be provided to the CCG PA.
 - .1 Erection package
 - .1 Deadline: with construction plan (ref sect, 011100)
 - .2 Deliverables:
 - .2 Written plan: Outline all procedures and methods to be employed to:
 - .1 Erect the tower;
 - .2 Field remedies to address any damage to the coating system incurred during transportation and erection.

1.4 Quality Assurance

- .1 CCG's minimum inspection requirements are detailed below. The Contractor shall be responsible to notify CCG of the date and time that the works may be inspected.
- .2 During installation.



PART 2 - PRODUCTS

2.1 Tower (provide by CCG)

- .1 Tower is as detailed in Appendix B3 – Contract Drawings
 - .1 Tower is fabricated with a bolting flange between each section.
 - .2 Tower will be supplied in three individual sections.
 - .3 Original engineered drawings are provided as reference for the purposes of determining foundation design.

2.2 Grout

- .1 Sika M-Bed or approved equivalent.

PART 3 - EXECUTION

3.1 Handling of Material and Transportation

- .1 The Contractor is to take all necessary precautions to avoid damage to the tower members or to tower coating during transport, unloading and erection. All components or damaged members shall be immediately reported to MCI Engineering.

3.2 Site preparation

- .1 Complete installation of all foundation elements prior to tower erection.
- .2 Adjust supporting/leveling nuts to uniform elevation.

3.3 Erection

- .1 Ensure that tower is plumb and level.
- .2 Tighten the first nut in EACH connection using turn of nut method associated to the length of bolt provided. The second nuts shall be snug tight.

3.4 Grout

- .1 Install grout between the tower base plate and mounting surface in accordance with manufacture's recommendations.
- .2 Ensure drainage outlets are installed within the grout pad to prevent the accumulation of moisture within the tower base.
 - .1 Drainage elements are anticipated to be constructed of 13mm PVC tubing or similar.



SECTION: 310099 FOUNDATIONS

PART 1 - GENERAL

1.1 Scope of Work

- .1 Work of this section includes the design, supply and installation of the following:
 - .1 Supporting foundation for new the ATON.
 - .1 Bidders may assume a reinforced concrete slab on grade having surface dimensions of (3.05 x 3.05 x 0.90m) for the purposes of initial estimation and project costing.
 - .1 Foundation is intended to be constructed upon the existing helipad as detailed previously and as noted in the contract drawings.
 - .2 Geotechnical investigation has been completed. The designer may reference the information provided in Appendix B4.
 - .2 Services of a qualified surveyor to ensure that the new foundation and anchor elements are constructed along the existing range centerline.

1.2 Related Sections

- .1 Section 033000 - Concrete Work.
 - .1 Section details requirements for concrete supply, placement and finishing.

1.3 References

- .1 Work under this section shall be undertaken in strict conformance with all listed references, In the case of any conflict or discrepancy the more stringent requirements shall apply.
 - .1 Canada Labour Code Part II
 - .2 NRC-CNRC National Building Code of Canada
 - .3 Ontario Occupational Health and Safety Act and Regulations

1.4 Existing conditions

- .1 Historical records indicate the island upon which the site is located is constructed of imported rip rap founded upon the bed of the existing lake.

1.5 System Description

- .1 The foundation element(s) is to provide a stable base for the ATON detailed in Appendix B3 – Contract Drawings.



- .1 Foundation elements shown are for bidding purposes only. Actual size and construction method is to be determined in consideration of the findings of an appropriate geotechnical investigation completed by the successful Contractor.
- .2 Top of foundation proposed is critical to ensure that the new navigational lantern will be visible above the historical ATON to maintained to the east.
- .3 Anchor bolts may deviate from those shown in consideration of the Project Engineer's assessment of local requirements.

- .2 It is critical that the center of the constructed foundation is installed along the existing range centerline.

1.6 Design Requirements

- .1 Foundation is to be designed to resist all anticipated dead and live loads.
- .2 Design must be completed in consideration of the findings of the geotechnical investigation completed at this location. Borehole logs are presented in Appendix B4.

1.7 Performance Requirements

- .1 Expected service life of this element is 50 years+. The constructed foundation element is expected to perform as reasonably expected throughout this period.

1.8 Submittals

- .1 The following submittals are to be forwarded to CCG PA:

.1 Foundation Design

- .1 Deadline: With design package (Section 011100)

.2 Deliverables:

- .1 Engineered drawings. Drawing shall be stamped and signed by an engineer licensed to practice in the Province of Ontario.

.1 Drawings must detail:

- .1 Plan, elevation and relevant section views of the proposed installation;
- .2 All incorporated products and/or performance parameters for bulk materials (i.e. ready mix concrete)
- .3 Any pertinent commentary concerning construction of the proposed foundation and anchorage element of the proposed facility.

- .2 Summary Report (if necessary). The summary report shall contain all additional technical references and requirements not otherwise detailed within the engineered drawings (i.e. chemical adhesive anchors -> manufacturer's installation instructions).



.2 Foundation and Anchorage Maintenance Package

.1 Deadline: With Project Maintenance Package (Section 011100)

.2 Deliverables:

.1 Amended project design drawings noting adherence, or any approved deviation completed during construction

1.9 Quality Control

.1 CCG's minimum inspection requirements are detailed below. The Contractor shall be responsible to notify CCG of the date and time that the works may be inspected.

.1 Onsite throughout installation of all critical foundation elements.

PART 2 - PRODUCTS

1.1 General

.1 Products shall be as stipulated by the Contractor's Engineer.

.1 Where concrete products are stipulated they are expected to conform to the requirements indicated in Section 033000, unless otherwise approved in writing by the CCG PA.

PART 3 - EXECUTION

1.1 General

.1 Installation shall be undertaken in accordance with the Contractor's engineered drawings and accompanying materials as contained in the Contractor's Summary Report.



Fisheries and Oceans
Canada

Pêches et Océans
Canada

Canadian
Coast Guard

Garde côtière
canadienne



APPENDIX B1: SITE LOCATION AND PHOTOGRAPHS

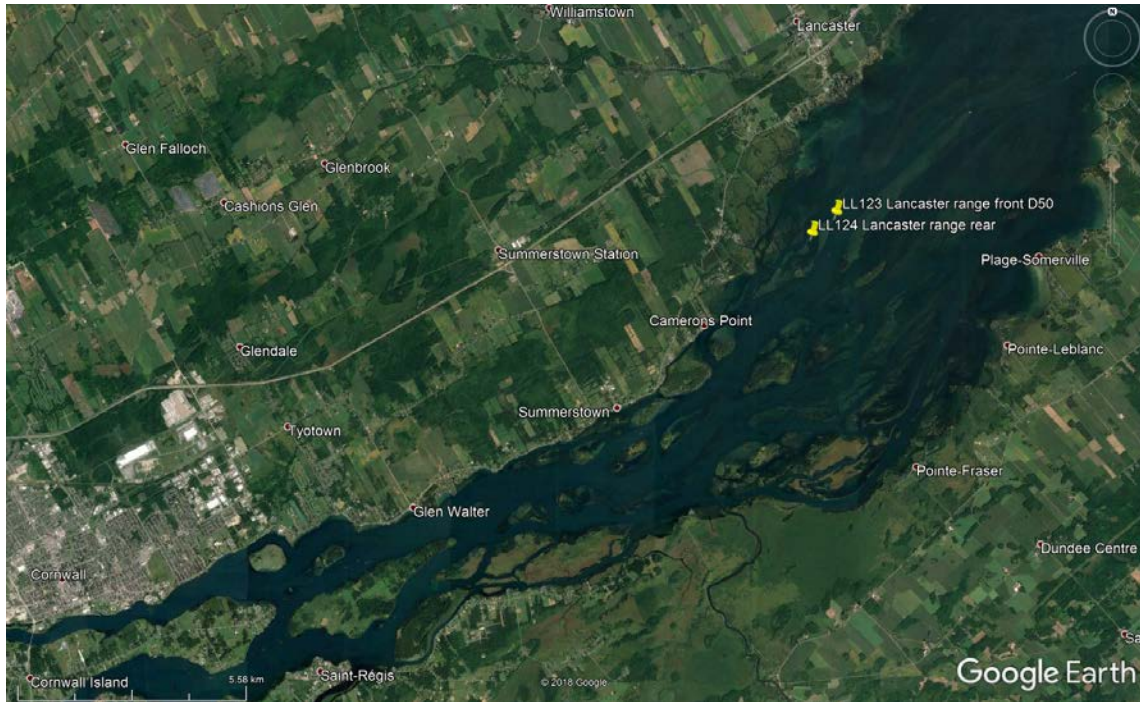

Project Location

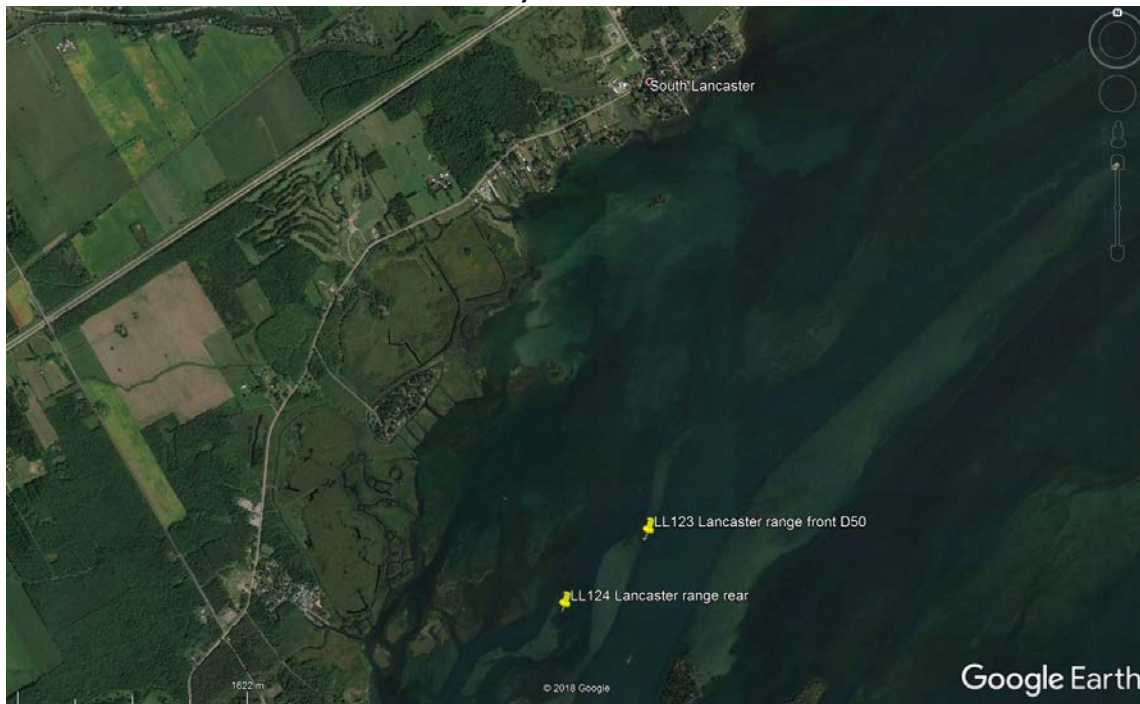

Project Location



Fisheries and Oceans
Canada

Pêches et Océans
Canada

Canadian
Coast Guard

Garde côtière
canadienne

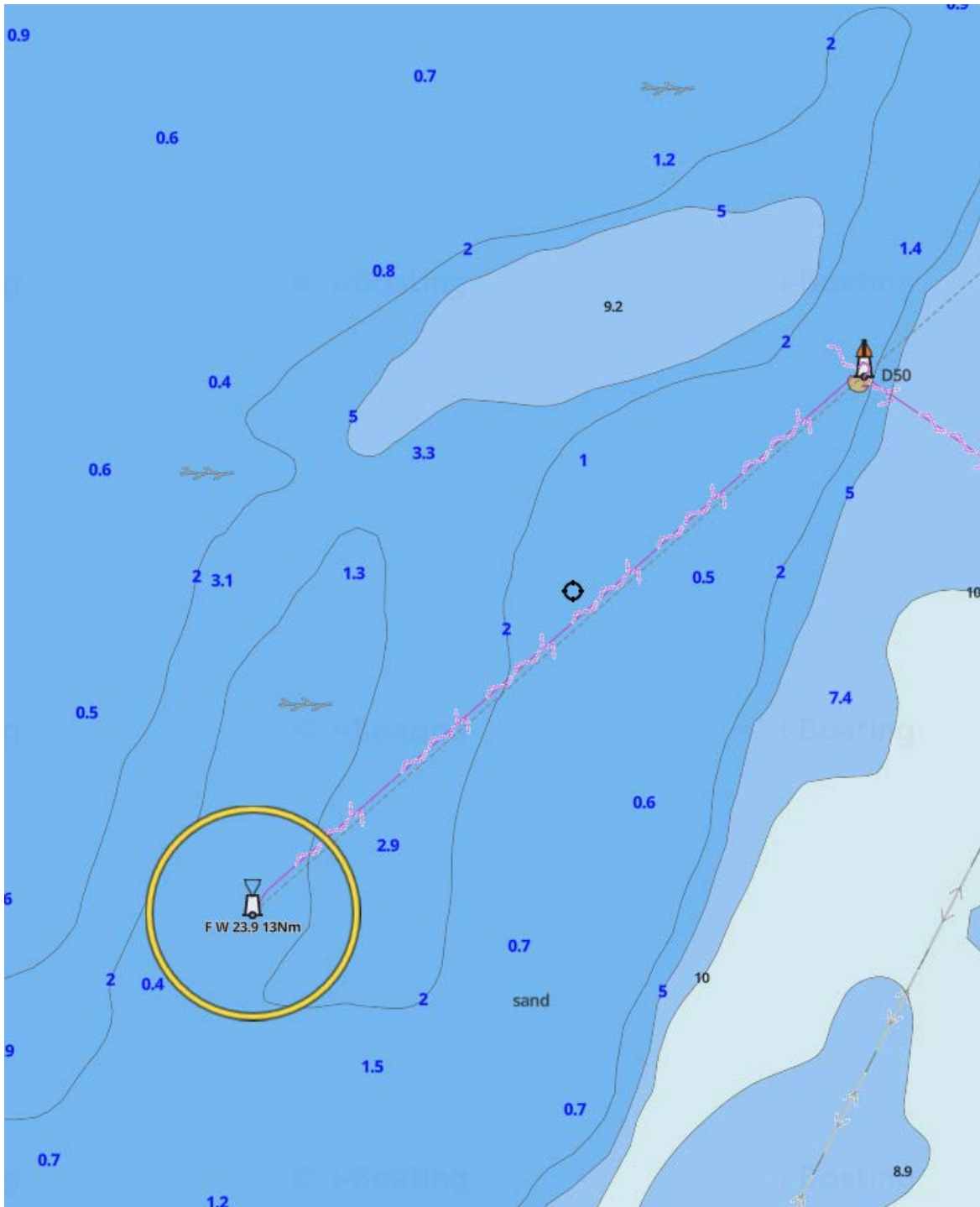

Approximate water depths vicinity of project location



Fisheries and Oceans
Canada

Pêches et Océans
Canada

Canadian
Coast Guard

Garde côtière
canadienne



Existing ATON



Proposed Location of new tower



Fisheries and Oceans
Canada

Pêches et Océans
Canada

Canadian
Coast Guard

Garde côtière
canadienne



Proposed center of
new tower
foundation

Proposed location of new tower



Fisheries and Oceans Canada / Pêches et Océans Canada

Canadian Coast Guard

Garde côtière canadienne



APPENDIX B2 – SUMMARY OF CONTRACT SUBMITTALS (a)

Sect 011100 General Requirements		Sect 013530 Health and Safety Requirements	Sect 013543 Environmental Procedures	Sect 024116 Demolition	Sect 033000 Concrete Work	Sect 310099 Foundations (c)
Deliverable	Deadline					
Detailed Schedule	<i>10 working days following award</i>					
Project Participants Listing	<i>With schedule</i>					
Design Package	As detailed in Contractor's submitted schedule					<i>Foundation design</i>
Construction Plan	As detailed in Contractor's submitted schedule (b)	<i>Project specific safety program</i>	<i>Environmental protection plan</i>		<i>Concrete placement plan</i>	
Maintenance Package	<i>30 days following substantial completion</i>			<i>Waste disposal receipts or records of disposal</i>	<i>Concrete test results</i>	<i>Foundation and anchorage maintenance package</i>

- a) Requirements of Section 013300 Submittal Procedures govern all submissions
- b) Documents to be submitted 10 days prior to mobilization
- c) Submissions may be combined were feasible, for clarity electrical, foundation, and marine cable haul system drawings may be combined for each individual submittal



Fisheries and Oceans
Canada

Pêches et Océans
Canada

Canadian
Coast Guard

Garde côtière
canadienne



APPENDIX B3 – DRAWINGS

Vendor / Sous-traitant

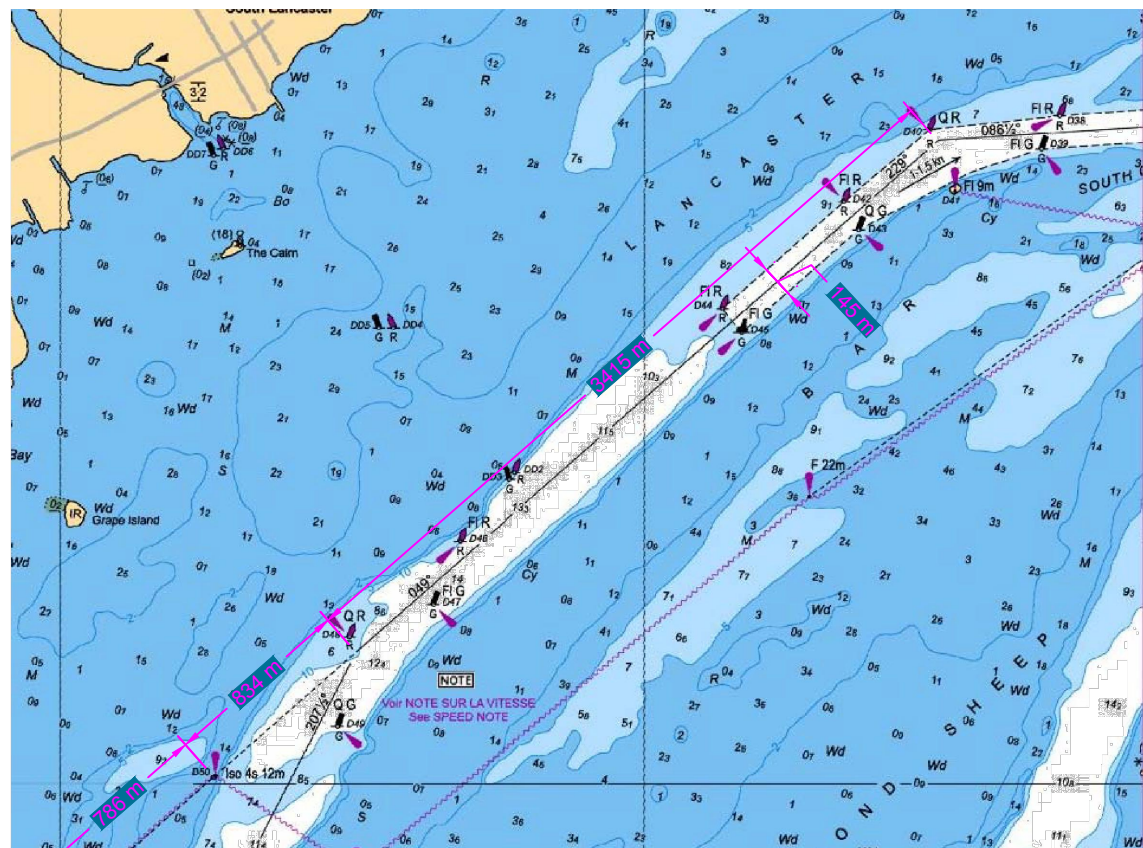

PLAN VIEW

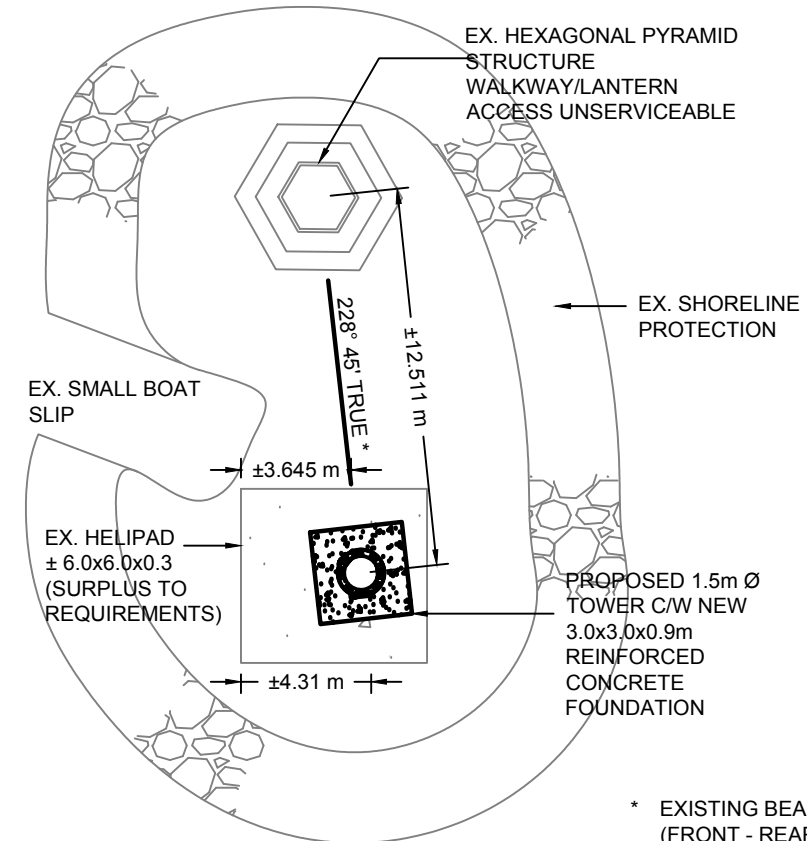

* EXISTING BEARING (FRONT - REAR) TOWER MUST BE MAINTAINED

NEW NAVIGATIONAL EQUIPMENT BY CCG (GREEN, ISO 2s FL / 2s EC) C/W WITH ALL APPURTENANCES

NEW 7.4m - 1.5m Ø TOWER (CLAYMAR) C/W DAYMARK MOUNTING PLATFORM
1. HANDRAILS AND DECK COATED RED
2. DAYMARK TO BE RELOCATED AT FUTURE DATE

EXISTING ATON EQUIPMENT TO BE SALVAGED AND RETURNED TO COAST GUARD

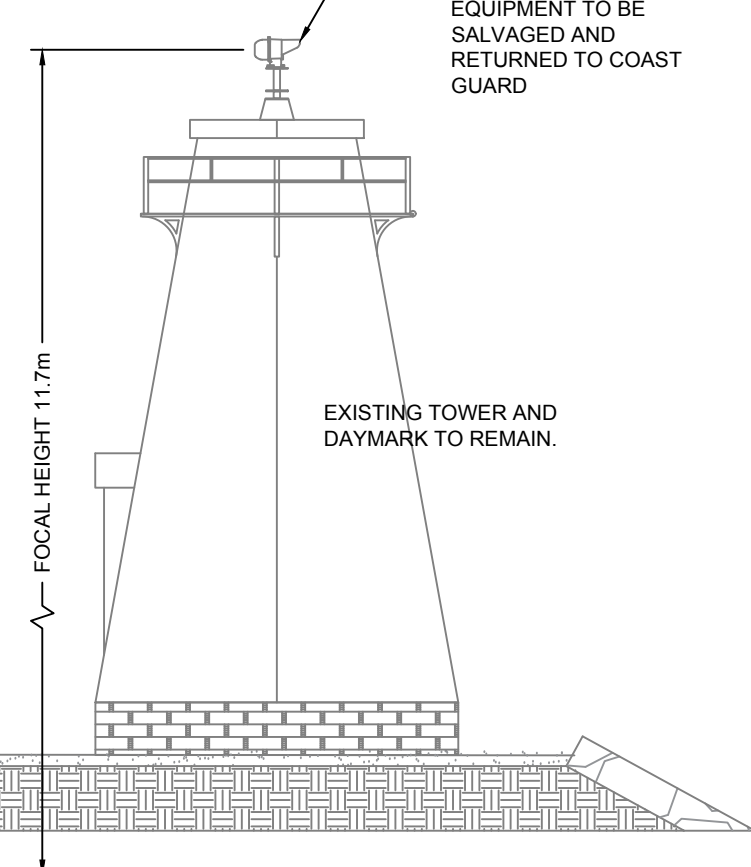
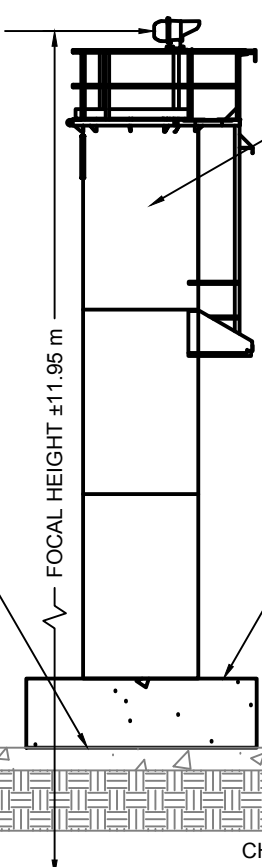

EX 6.0x6.0x0.3m CONCRETE HELIPAD (SURPLUS TO REQUIREMENTS)

NEW 3.0x3.0x0.9m REINFORCED CONCRETE FOUNDATION

EX. SHORELINE PROTECTION

CHART DATUM

EXISTING TOWER AND DAYMARK TO REMAIN.

0	DESCRIPTION	BY	yyyy-mm-dd
rev	description	by	date
Asset - Actif			
LL 123 - LANCASTER FRONT D50			
Front Range			
Drawing - Dessin			
PROPOSED CONSTRUCTION			
designed - conception		date	
JIBB.D		2018-05-29	
drawn - dessiné		date	
JIBB.D		2018-05-29	
checked - vérifié		date	
GUAY.MP		2018-05-29	
approved - approuvé		date	
RICHARD.L		YYYY-MM-DD	
CCG ref. no. - no. réf. GCC		scale - échelle	
EWTM-8010-0123000		VARIABLES	
drawing no. - no. dessin		sheet-feuille	rev
1		01/01	0

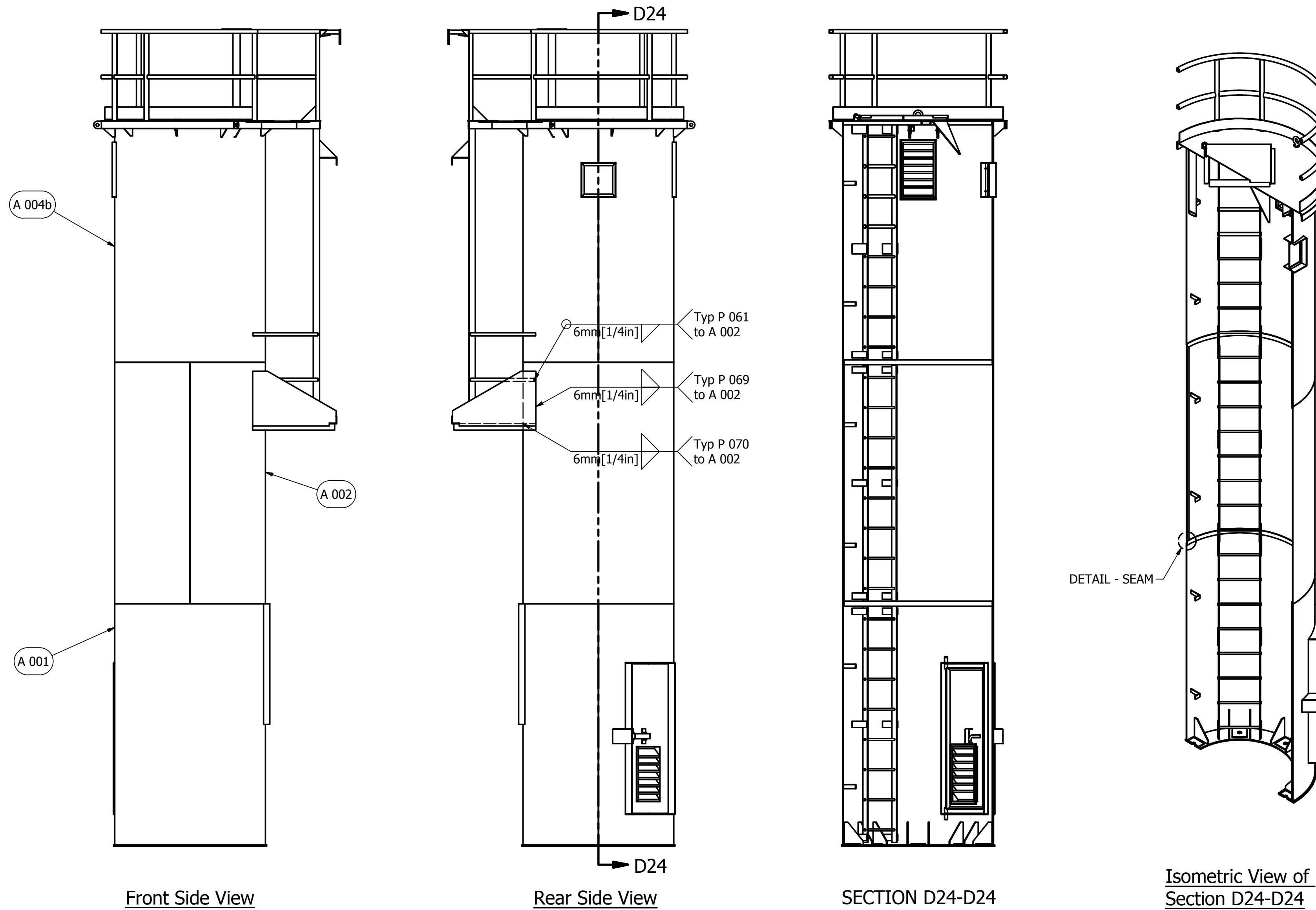
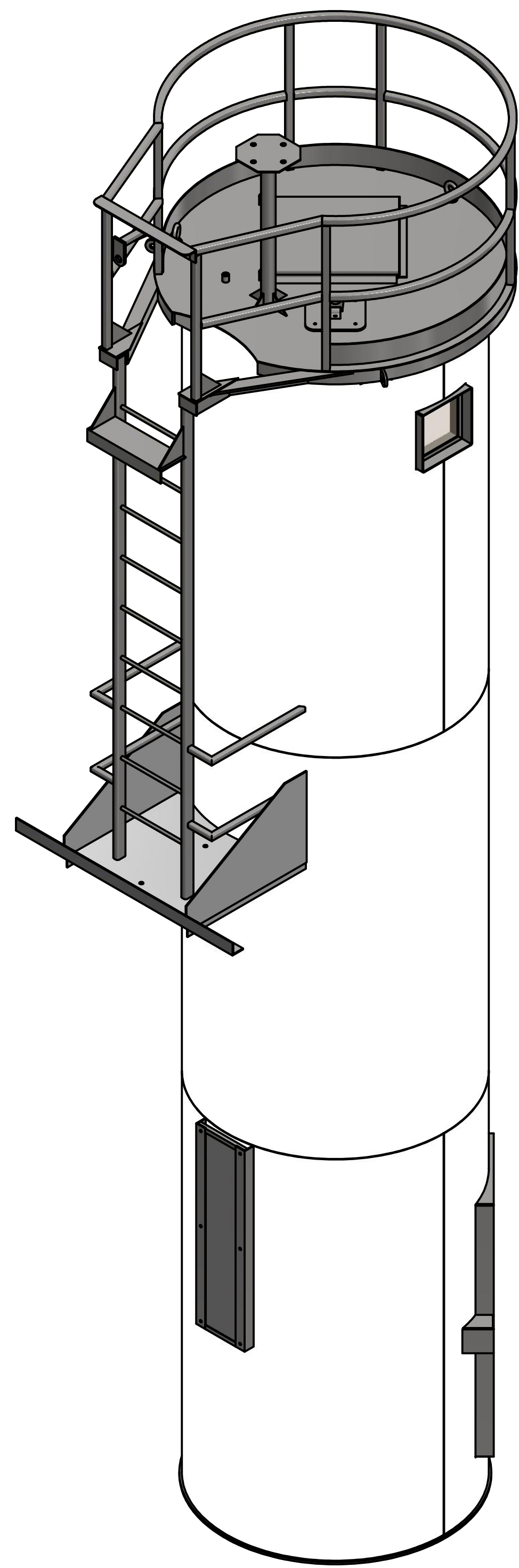

Front Side View

Rear Side View

SECTION D24-D24

Isometric View of Section D24-D24

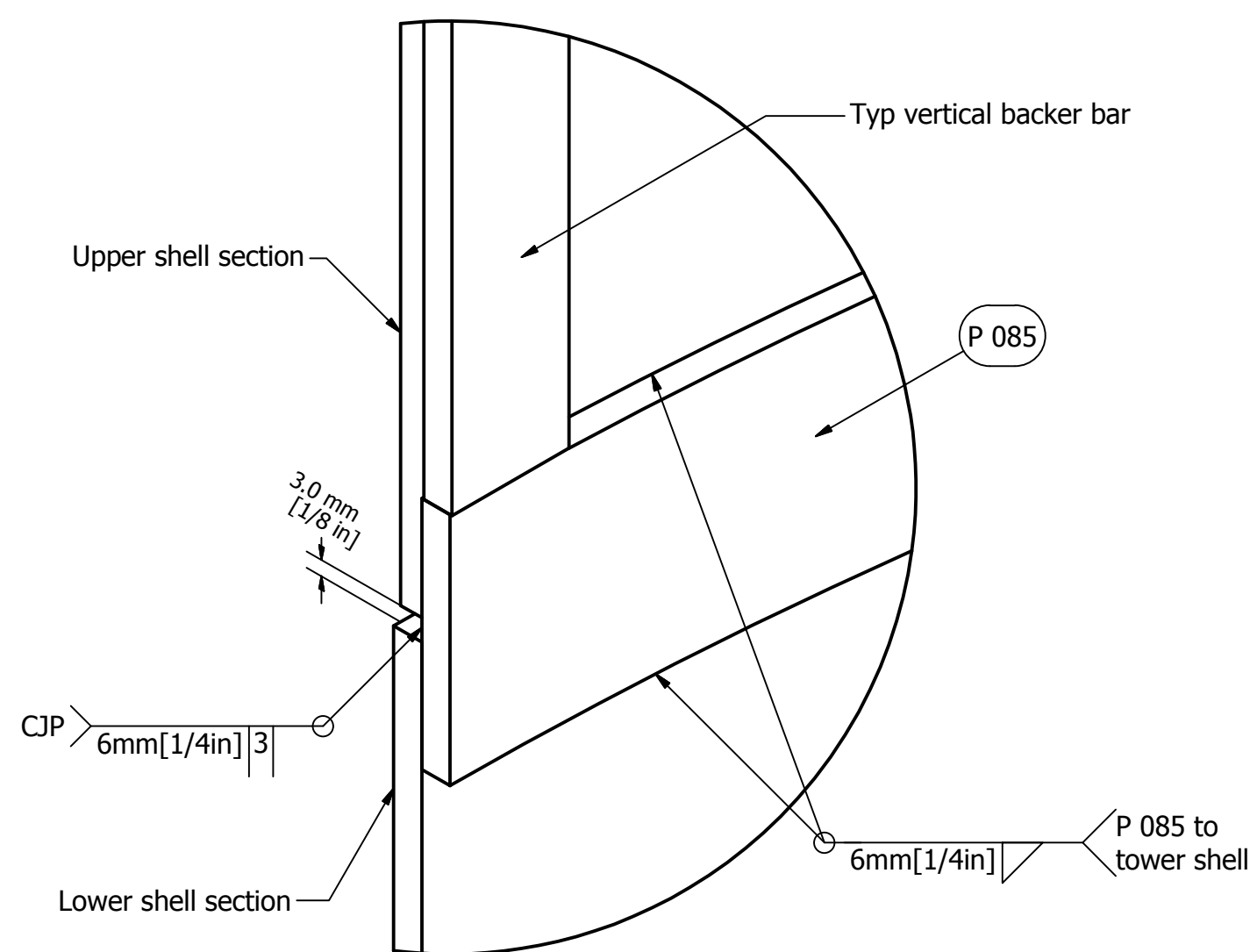

DETAIL - SEAM
Typ Section Seam Detail

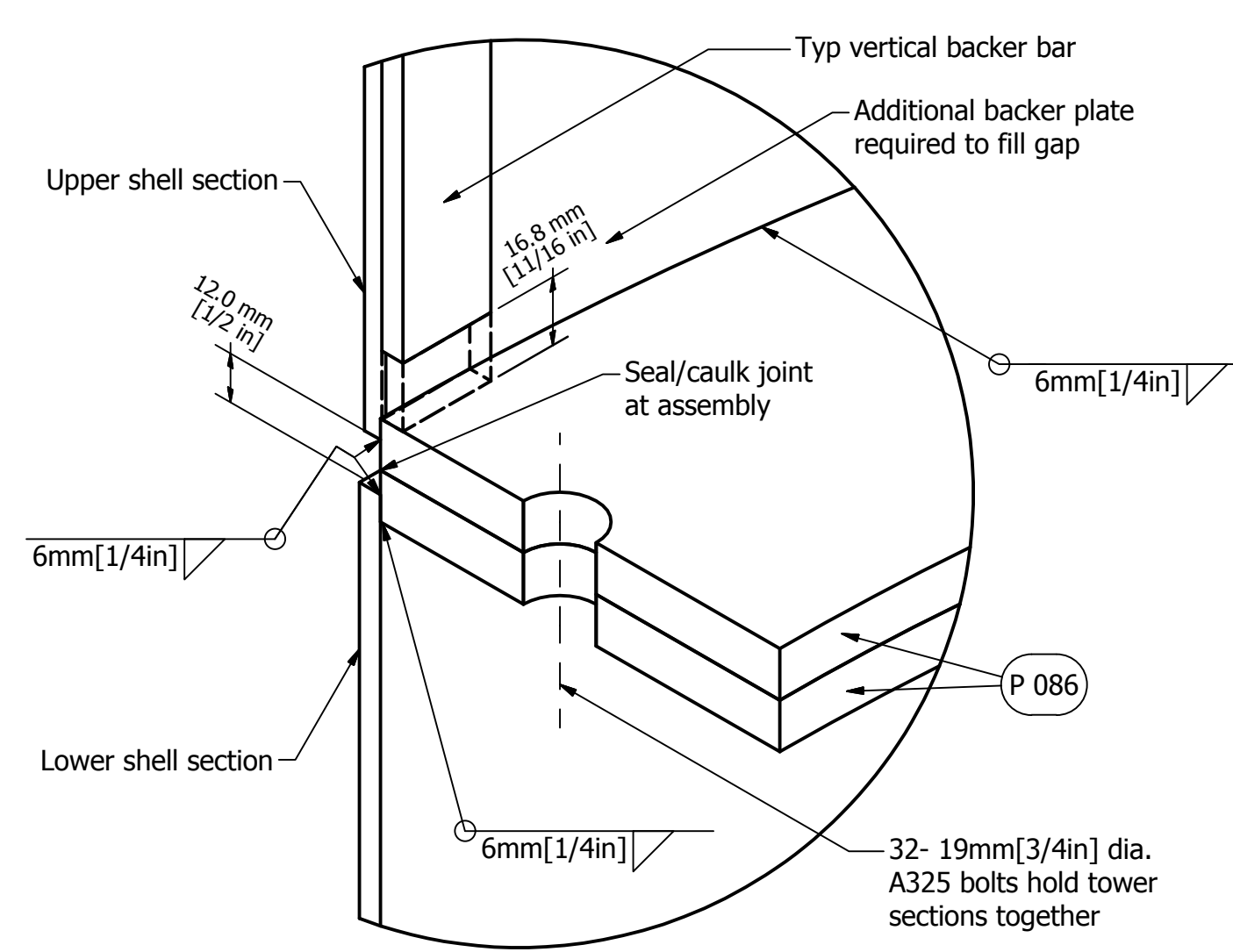

Optional Splice Ring Detail

Note: Splice can be utilized in place of the usual backer bar, in situations where erecting the tower in multiple sections is advantageous and/or necessary

Notes:

1. Design Location - Great Lakes, Ontario shore line, from Cornwall to Thunder Bay. Wind design loads include allowance for wind speed up on hill top location (Maximum hill height = 45m).
2. Design shall be in accordance with the National Building Code of Canada. (NBC 2005), NBC 1995 Structural Commentaries (wind) and CSA S16-01.
3. All work to comply with CSA S16-01, NBC 2005 & Canada Labour Code.
4. **Materials**
 - Structural Shapes - CSA G40.21M, Grade 300W.
 - HSS - CSA G40.21M, Grade 350W, CL. C.
 - Plates & Bar - CSA G40.21M Grade 300W.
5. **Welding**
 - Electrodes - E49XX (E70XX).
 - All connections shall be fully welded U.N.O.
 - Fabricator must be certified by CWB to CSA standard W47.1, division 1 or 2.1
 - Shall be in accordance with CSA S16-01, W47 & W59, latest version.
 - Remove all weld splatter, sharp edges & corners
 - Provide 6x50mm[1/4x2in] Backer Bar on all tower fabricated seams, weld 100% inside.
6. **Galvanization**
 - Tower to be hot dip galvanized
 - Hot dip galvanizing shall conform to CAN/CSA-G164
7. **Bolts**
 - Structural Bolts - ASTM A325 U.N.O.
8. **Paint**
 - Primer - CAN/CGSB-1.40 ALKYD Type.
 - Paint - CAN/CGSB-1.60 ALKYD Enamel or High Build Mastic Epoxy or Polyurethane.
 - Apply in accordance with CGSB 85-GP-14M.
9. **Fall Protection**
 - Supply and install DBI-SALA "LAD-SAF" system in accordance with manufacturer's instructions.
 - Installation must allow for simultaneous use by two personnel.
 - D-Ring Anchorage - DBI SALA D-Ring Anchorage Connector, Stainless Steel D-Ring, Stainless Steel Anchorage Plate with 9/16in Dia. mounting holes.
 - 9.5mm[3/8 in] doubler Plate to be installed as shown.
10. **Manufacturing Tolerance**
 - Maximum out of roundness of 1% on diameter, $D_{max} - D_{min} = 0.6in$.

Canadian Coast Guard 24' Claymar Tower With Daymark Attachment

PARTS LIST		
ITEM	QTY	DESCRIPTION
A 001	1	Bottom Assembly
A 002	1	8' Middle Assembly
A 004b	1	Top Assembly
P 085	2	Backer Bar
P 086	4	Splice Ring (Optional)

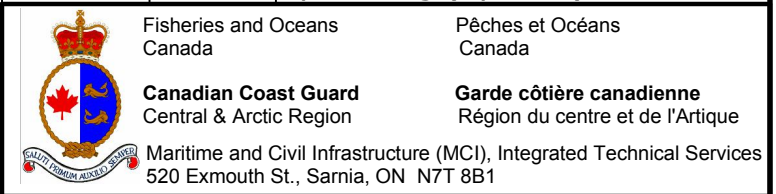

Cover Page				
FILE No.	06044	SCALE:	N.T.S.	
DWG No.	1	of 22		
Rv.	DATE	DESCRIPTION	DRAWN	APP'D
0	N/A	DRAWING INITIATED	A.W.	A.W.
1	9 Mar 13	UPDATED DRAWINGS BASED ON GLOS REVISIONS	E.G.	B.Y.
2	26 Apr 13	TOWER DRAWING COMPLETED	E.G.	B.Y.
3	5 Nov 13	REDESIGNED COVER PAGE AND SPLICE DETAILS	G.L.	B.Y.

All Dimensions in mm unless otherwise noted.



GLOS ASSOCIATES INC.
3535 North Service Road East
Windsor, Ontario
NBW 5R7
TEL: (519) 946-6750
FAX: (519) 946-6753

ISO 9001:2000 REGISTERED PROJECT: 06044

Notes

- DESIGN LOCATION - GREAT LAKES, ONTARIO SHORE LINE, FROM CORNHALL TO THUNDER BAY. WIND DESIGN LOADS INCLUDE ALLOWANCE FOR WIND SPEED UP ON HILL TOP LOCATION (MAXIMUM HILL HEIGHT 45m.)
- DESIGN SHALL BE IN ACCORDANCE WITH THE NATIONAL BUILDING CODE OF CANADA (NBC 2005), NBC 1995 STRUCTURAL COMMENTARIES (WIND) AND CSA 516-01.
- ALL WORK TO COMPLY WITH CSA 516-01, NBC 2005 & CANADA LABOUR CODE
- MATERIALS**
 - STRUCTURAL SHAPES - CSA G40.21M GRADE 300H
 - HSS - CSA G40.21M, GRADE 350M, CL. C
 - PLATES & BARS - CSA G40.21M, GRADE 300H
 - GRATING - TYPE 1944, WELDED, 32mm X 5mm (1 1/4" X 3/8")
 - SERRATED BEARING BARS, BAND EDGES, HOT DIPPED GALVANIZED FINISH.
 - PIPE - ASTM A53
- WELDING**
 - ELECTRODES: E60XX (E70XX)
 - ALL CONNECTIONS SHALL BE FULLY WELDED UNO.
 - SHALL BE IN ACCORDANCE WITH CSA 516-01, PART 4 AND W89, LATEST EDITION
 - REMOVE ALL WELD SPATTER SHARP EDGES & CORNERS.
 - PROVIDE 6x50 (1/4x2) BACKER BAR ON ALL TOWER FABRICATED PLATE SEAMS WELD 100% INSIDE.
- BOLTS**
 - STRUCTURAL BOLTS - ASTM A325 UNO.
 - SECONDARY CONNECTIONS - SAE J429, GRADE 5
- PAINT**
 - PRIMER: CAN/CGSB-140 ALKYD TYPE
 - PAINT: CAN/CGSB-160 ALKYD ENAMEL OR HIGH BUILD PASTIC EPOXY OR POLYURETHANE
 - APPLY IN ACCORDANCE WITH CGSB B5-GP-14P1.
- FALL PROTECTION**
 - PROVIDE FALL PROTECTION IN ACCORDANCE WITH CANADA OCCUPATIONAL HEALTH AND SAFETY REGULATIONS SECTION 12.10
 - SYSTEM HAS A MAXIMUM CAPACITY OF TWO USERS (1 USER + 1 RESCUER) WITH A MAXIMUM COMBINED HEIGHT OF 1.4 m (315 lbs) PER USER INCLUDING TOOLS AND EQUIPMENT
 - PROVIDE CAPACITY SIGNAGE AT BASE OF LADDER.
 - LADDER - DBI SALA "LAD-SAF" FLEXIBLE CABLE LADDER SAFETY SYSTEM
 - MINIMUM 4 RUNG ATTACHMENTS REQUIRED FOR TOP BRACKET INSTALLATION.
 - LADDER RUNGS ARE SUITABLE FOR CENTER MOUNTING OF TOP & BOTTOM BRACKETS
 - INSTALL AND MAINTAIN IN ACCORDANCE WITH MANUFACTURERS SPECIFICATIONS.
 - D-RING ANCHORAGE - DBI SALA D-RING ANCHORAGE CONNECTOR, STAINLESS STEEL
 - D-RING, STAINLESS STEEL ANCHORAGE PLATE WITH 3/8" DIA. MOUNTING HOLES.
 - 9.5 mm (3/8") DOUBLER PLATE TO BE INSTALLED AS SHOWN.
- FOUNDATIONS**
 - PROVIDE DETAILED FOUNDATION DESIGN FOR INDIVIDUAL LOCATIONS
 - CONCRETE - 25 MPa MINIMUM
 - ANCHOR RODS - CSA G40.21M GR. 300H
 - GROUT - SIKKA F1-BED STANDARD OR EQUAL
- MANUFACTURING TOLERANCE**
 - MAXIMUM OUT OF ROUNDNESS OF IS ON DIAMETER, $D_w - D_m = \pm 0.6$

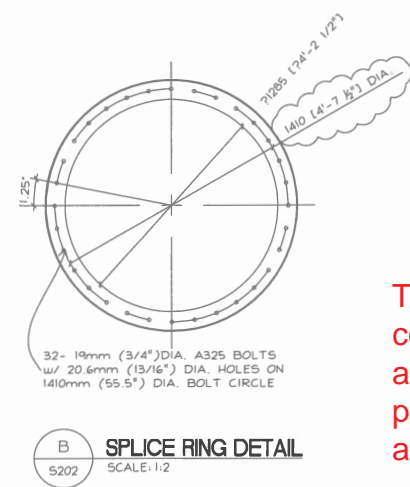
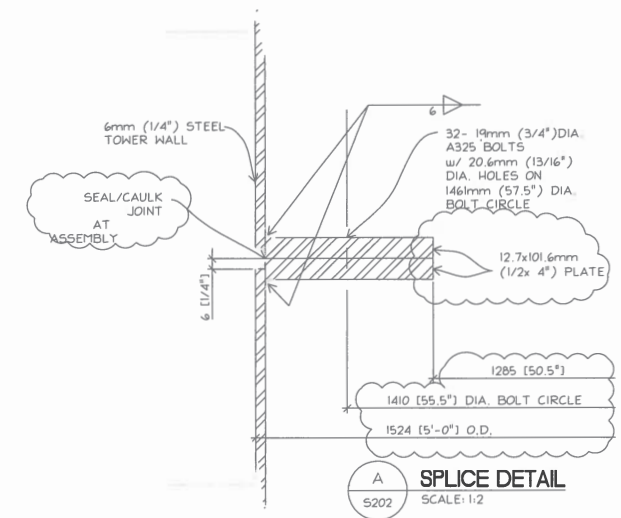

This drawing is to be considered a reference only and is provided for the purposes of communicating anticipated weights.

APPROXIMATE TOWER WEIGHTS

TOWER HEIGHT	6' TOP SECTION		8' TOP SECTION		INTERMEDIATE w/ LOWER DAYMARK PLATFORM		INTERMEDIATE w/ LOWER DAYMARK PLATFORM		4' INTERMEDIATE		8' INTERMEDIATE		6' BASE		8' BASE		TOTAL WEIGHT		
	(m)	(ft)	(kN)	(lbs)	(kN)	(lbs)	(kN)	(lbs)	(kN)	(lbs)	(kN)	(lbs)	(kN)	(lbs)	(kN)	(lbs)	(kN)	(lbs)	
3.658	12	9.0	2,030	-	-	-	-	-	-	-	-	-	-	6.9	1,550	-	-	15.9	3,580
4.877	16	-	-	10.6	2,380	-	-	-	-	-	-	-	-	-	-	8.9	2,000	19.5	4,380
6.096	20	-	-	10.6	2,380	5.1	1,150	-	-	-	-	-	-	-	-	8.9	2,000	24.6	5,530
7.315	24	-	-	10.6	2,380	-	-	7.9	1,785	-	-	-	-	-	-	8.9	2,000	27.4	6,165
8.534	28	-	-	10.6	2,380	-	-	7.9	1,785	4.0	900	-	-	-	-	8.9	2,000	31.4	7,065
9.754	32	-	-	10.6	2,380	-	-	7.9	1,785	4.0	900	7.1	1,595	-	-	8.9	2,000	34.5	7,760
10.973	36	-	-	10.6	2,380	-	-	7.9	1,785	4.0	900	7.1	1,595	-	-	8.9	2,000	38.5	8,660
12.192	40	-	-	10.6	2,380	-	-	7.9	1,785	-	-	7.1	1,595	-	-	8.9	2,000	41.6	9,355

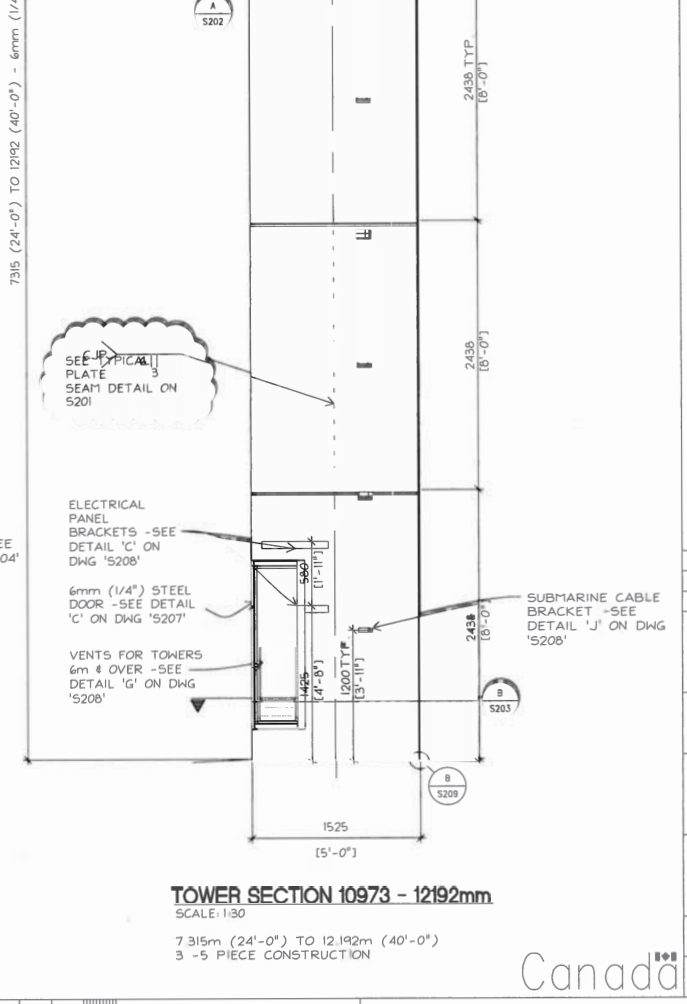
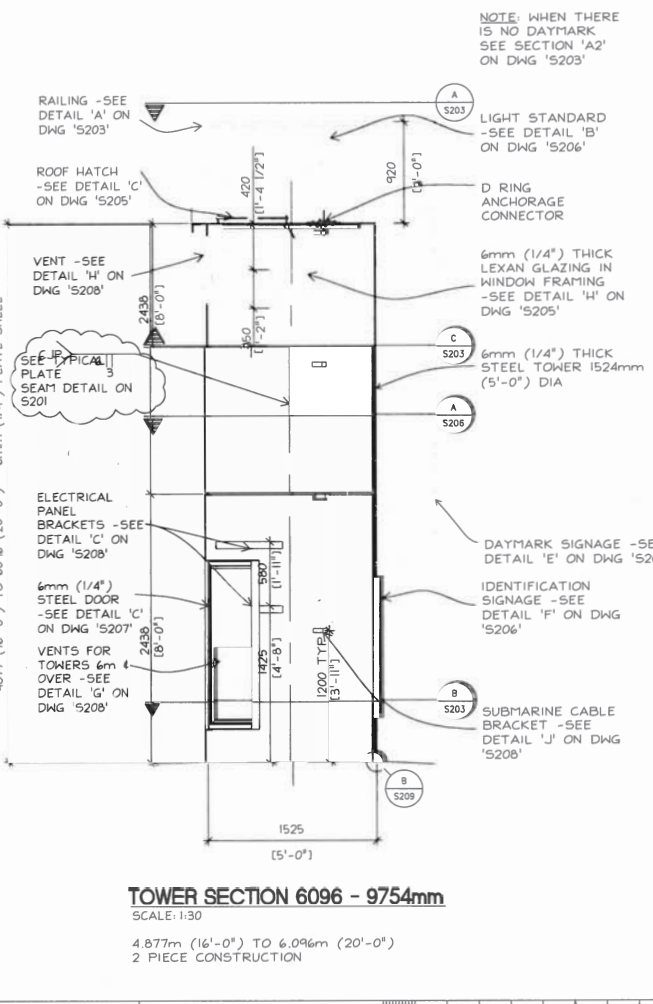
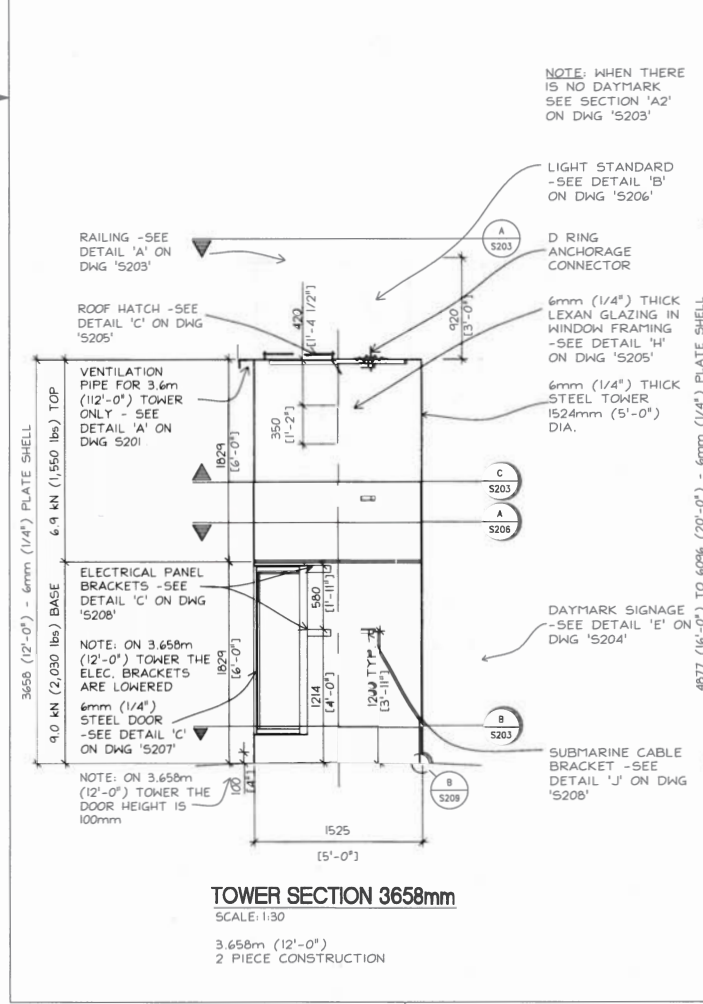

Revision	Date	By	Description
01	MAR 28/08	GLOS	MINOR REVISIONS AS NOTED

FACILITIES ENGINEERING AND CONSTRUCTION
FACILITES INGENIERIE ET CONSTRUCTION

project title
1524m (5'-0") DIA. CLAYMAR TOWER

drawing title
MODULAR TOWER SECTIONS FOR HELICOPTER LIFTS

date - date	drawn - dessine	checked - verifie	approved - approuve
04/05/2006	AS/AG/DP	DL	
scale - echelle	reference - reference	drawing no. - no du dessin	sheet
AS NOTED		S202	1





Fisheries and Oceans
Canada

Pêches et Océans
Canada

Canadian
Coast Guard

Garde côtière
canadienne



APPENDIX B4 – GEOTECHNICAL INFORMATION



Fisheries and Oceans
Canada

Pêches et Océans
Canada

Canadian
Coast Guard

Garde côtière
canadienne



APPENDIX B5 – MARINE ACCESS

.1 Marine Access

.1 Vessel(s) employed in the performance of the contract shall be certified as required by the Canada Shipping Act 2001 and its applicable regulations including Marine Personnel Regulation

.1 The Contractor shall ensure that the vessel(s) proposed for the work meets all requirements of the Canada Shipping Act 2001 and the applicable Regulations under the Canada Shipping Act.

.2 The Contractor shall provide copies of the following documentation to facilitate evaluation and award:

.1 Proof of vessel registration as a commercial vessel in accordance with the Canada Shipping Act 2001. Either one of two registrations will be accepted:

.1 Proof of commercial vessel registration in the Small Vessel Register (SVR) if less than 15 Gross Tons or;

.2 Proof of commercial vessel registration in the Canadian Register of Vessels (CRV) if more than 15 Gross Tons.

.3 NOTE: Pleasure Craft are not acceptable for the performance of this work – it must be a commercially registered vessel.

.2 Where the vessel is registered in the SVR:

.1 The Contractor shall provide identification of the primary operator of the vessel along with their Transport Canada candidate number.

.2 The Project Authority may, at his/her sole discretion, request the Contractor to provide a copy of any of the following at any time during the period of the resulting contract:

.1 Vessel certification and operation limitations within scope of work. Where the vessel is restricted, the operator shall ensure that the vessel can be used to safely perform the work in this specification;

.2 A copy of inspection according to the Small Vessel Compliance Program; Contractor shall submit proof of enrolment in the compliance program and;

.3 Either a copy of the initial inspection report or the most recent copy of an annual inspection report and;

.3 Where the vessel is registered in the CRV:

.1 The Contractor shall provide identification of the primary operator of the vessel along with their Transport Canada candidate number.

- .2 The Project Authority may, at his/her sole discretion, request the Contractor to provide a copy of any of the following at any time during the period of the resulting contract:
 - .1 The latest Annual Inspection Certificate endorsement for the proposed vessel;
 - .2 A copy of any restrictions that the vessel is operating under and the general sailing limitations of the vessel. Where the vessel is restricted, the operator shall ensure that the vessel can be used to safely perform the work in this specification.
- .2 Vessels and crew found to be in contravention of the act will not be permitted to be engaged in any elements of the works identified herein. In the event that a vessel or crew is found non-compliant a suitable replacement vessel and/or crew will be retained by the Contractor at their sole expense.



Fisheries and Oceans
Canada

Pêches et Océans
Canada

Canadian
Coast Guard

Garde côtière
canadienne



APPENDIX B6 – CCG ROTARY WING SUPPORT

.1 Rotary Wing (Helicopter) Access.

- .1 In the case where the Contractor will be providing its own helicopter access the Project Authority will require the Contractor to meet the requirements outlined below and provide the PA with all identified information or certifications prior to use of the helicopter.
- .2 Helicopter(s), Operators and Crew employed in the performance of the contract must be certified and licensed to operate in accordance with the requirements of the Aeronautics Act and the Canadian Aviation Regulations.
- .3 Helicopters utilized in the performance of the work must be equipped with CCG mandatory safety equipment as detailed in CCG FO 218, *Helicopter Safety Equipment Requirements*.
- .4 Passengers embarked aboard the helicopter are to be provided with Personal Protective Equipment (PPE) as detailing in CCG FO 218, *Helicopter Safety Equipment Requirements*.
- .5 In no case may the Contractor overrule or supersede the discretion of the Pilot in Command or in other way jeopardize the safety of the airframe or the employees engaged in the performance of the work.
- .6 The Contractor's submitted Project Specific Safety Program must address the hazards associated with rotary wing operations including slinging.
- .7 The Contractor's submitted Construction Plan must detail planned rotary wing operations, inclusive of all routing, loads (internal/external), landing and refueling areas.

.2 Canadian Coast Guard Helicopter Support

- .1 The Contractor may consider the use of either CCGs Bell 429 or Bell 412 in support of the execution of the works. Use of CCGs rotary wing assets will be subject to availability of airframe, crew and CCGs operational priorities.
 - .1 Relevant operating parameters for each airframe are provided in Table 1.
- .2 Use of CCGs rotary wing assets will be subject to full cost recovery from any amount payable under the Contract. A representative example is provided for consideration

TABLE 1			
Airframe/ Operating Characteristics	Notes	Bell 429	Bell 412
Flight rules		Visual, daylight operations only	Visual, daylight operations only
Maximum Lift Capacity (lbs)	(a)	2200 (1750)	2900 (2200)
Cruise Speed (kts)		125	110
Operating Rate (\$/h)		\$ 1748.00	\$ 1871.00
Fuel Burn Rates (l/h)		297	428
Fuel consumption cost (\$/h)	(b)	320	460
Passengers	(c)	7 max (3)	6 max (4)
Per diem rate, Ontario (\$/day/crew)	(d)	\$ 250.00	
Per diem rate, Nunavut (\$/per)		\$ 550.00	
Overtime rate (\$/h/crew)	(e)	\$ 75.00	

- a) Assumes airframe fully stripped and minimal fuel load, value shown in brackets is standard threshold for comparison.
- b) Value provided for budgeting only, recovery will be based on actuals. Fuel consumption cost assumes fuel cost of \$1.08
- c) Value excludes Pilot. Assumes airframe configured to maximum passenger configuration value shown in brackets is typical
- d) Value provided for budgeting only, recovery will be for actual costs incurred. Travel costs will be incurred in accordance with Government of Canada National Joint Committee Travel Directive.
- e) Overtime standard rate