

**ADDENDUM NUMBER: TWO**

**ISSUED BY: SEPW Architecture Inc.**  
109 – 3725 Pasqua St., Regina, SK. S4S 6W8  
PH. (306) 569-2255

**PROJECT: INTERIOR RENOVATION  
PROJECT #42/17  
REGINA, SASKATCHEWAN**

This Addendum forms part of the Contract Documents and amends the original Drawings and Specifications dated 2018-07-13, previous Addenda if applicable and as noted below. This Addendum consists of 1 page plus attached Specifications and Attachments as listed below. Ensure that all parties are aware of all items included in this Addendum.

**The following revised or additional Attachments accompany and form an integral part of this Addendum:**

<b>Attachment</b>
AR 1 Security Bars
AR 2 Security Bars
AR 3 Security Bars

**A-2-1 REFERENCE SECTION 05 50 00 METAL FABRICATIONS**

ADD: the following clause to Section 05 50 00:

**2.8 SECURITY BARS**

1. Galvanized metal.
2. As noted in drawings.

**A-2-2 REFERENCE DRAWING A2 & M3.1**

CLARIFICATION: provide security bars as detailed in drawings AR1, AR2 and AR3 in locations as noted in drawings. Adjust dimensions to suit duct size.

**A-2-3 GENERAL QUESTIONS**

1. Q: *Does Glycol have to be drained for whole building?*  
A: No.
2. Q: *Approximately how many gallons of glycol will have to be stored*  
A: The hydronic heating system does not have glycol in it.

**END OF ADDENDUM 2**

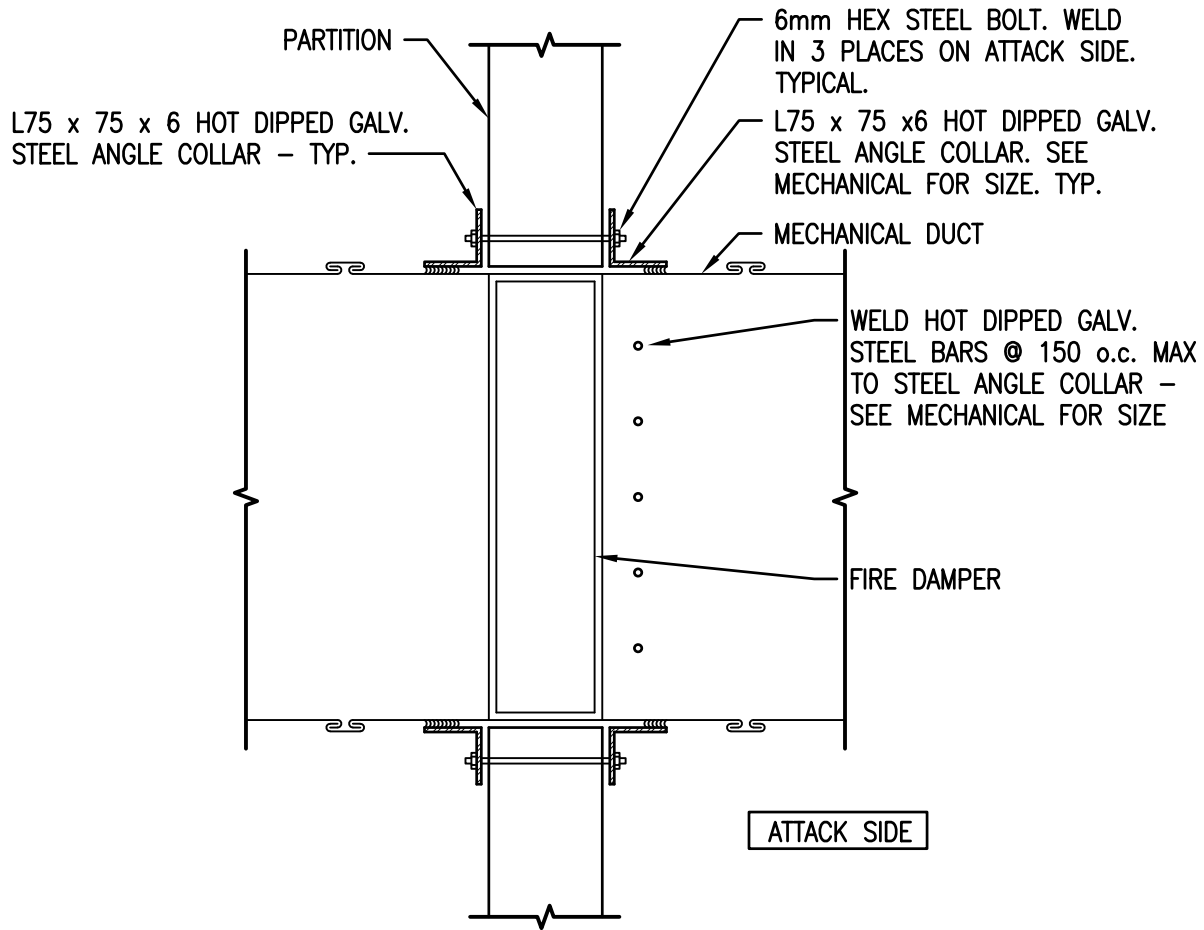

1 SECURE DUCT DETAIL – PLAN VIEW  
1:10



**SEPW Architecture Inc.**

■ 109 - 3725 Pasqua Street, Regina, SK, S4S 6W8 ph: (306) 569-2255  
 □ 204 - 2100 Alrport Drive, Saskatoon SK, S7L 6M6 ph: (306) 652-6457  
 ■ website: www.sepwa.ca

PROJECT TITLE  
HSU INTERIOR RENOVATION  
REGINA, SASKATCHEWAN

DRAWING TITLE  
SECURITY BARS

DATE  
2018-10-11

SCALE  
AS SHOWN

DRAWN  
VS

CHECKED  
GP

PROJECT NO.  
42/17

DRAWING NO.

**AR1**

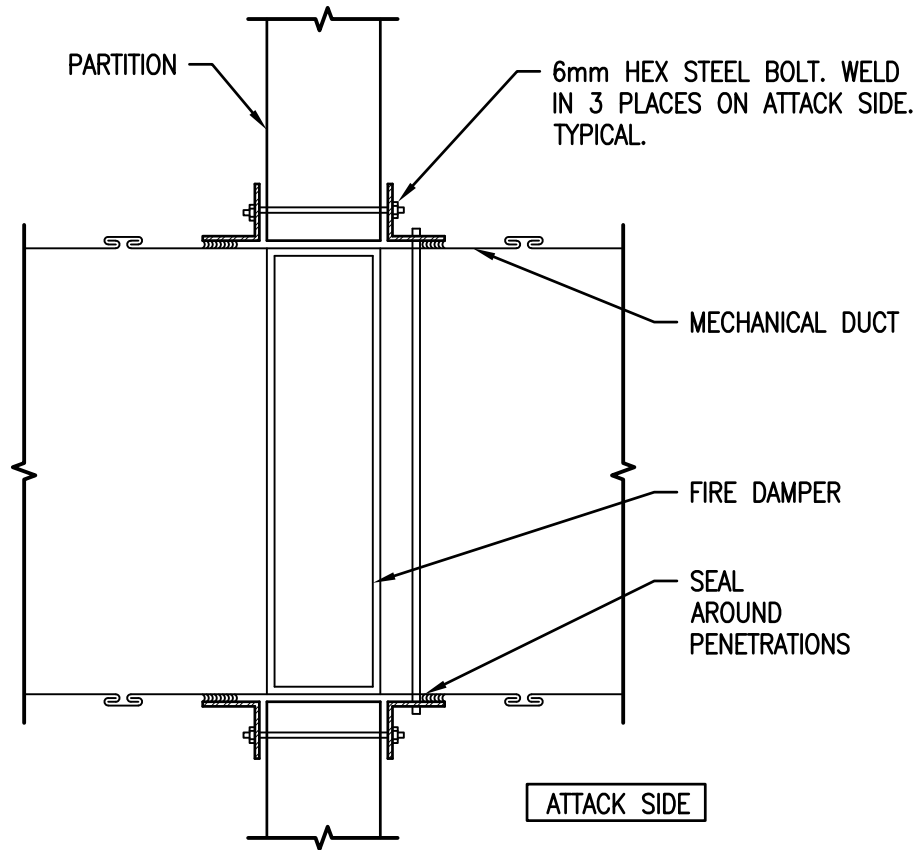

1 SECURE DUCT DETAIL – SECTION  
1:10



**SEPW Architecture Inc.**

■ 109 - 3725 Pasqua Street, Regina, SK, S4S 6W8 ph: (306) 569-2255  
 □ 204 - 2100 Alrport Drive, Saskatoon SK, S7L 6M6 ph: (306) 652-6457  
 ■ website: www.sepwa.ca

PROJECT TITLE  
HSU INTERIOR RENOVATION  
REGINA, SASKATCHEWAN

DRAWING TITLE  
SECURITY BARS

DATE  
2018-10-11

SCALE  
AS SHOWN

DRAWN  
VS

CHECKED  
GP

PROJECT NO.  
42/17

DRAWING NO.

**AR2**

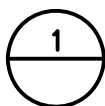
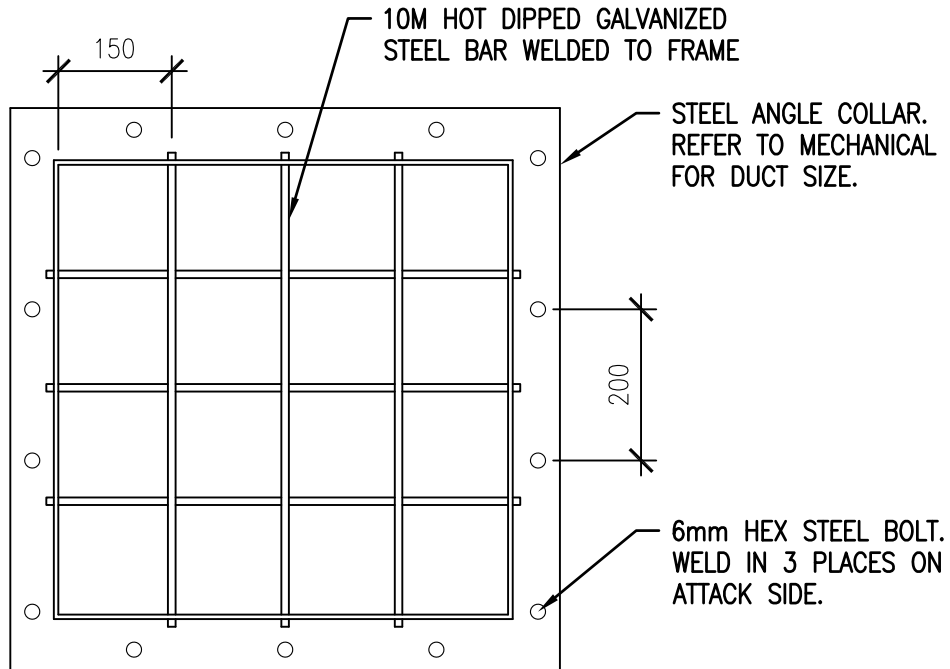

## SECURE DUCT DETAIL – ELEVATION

1:10

REFER TO MECHANICAL FOR DUCT LOCATIONS. PROVIDE AT ALL SECURE WALL LOCATIONS, REFER TO PARTITION SCHEDULE.

2018/10/10 X:\SEPW PROJECT FILES\2017\42-2017 HSU F DIV HQ BLDG\ACAD\WORKING DRAWINGS\AR SHEETS\PLOT FILES\AR 1 2 3



**SEPW Architecture Inc.**

■ 109 - 3725 Pasqua Street, Regina, SK, S4S 6W8 ph: (306) 569-2255  
 □ 204 - 2100 Alrport Drive, Saskatoon SK, S7L 6M6 ph: (306) 652-6457  
 ■ website: www.sepwa.ca

PROJECT TITLE  
**HSU INTERIOR RENOVATION  
 REGINA, SASKATCHEWAN**

DRAWING TITLE  
**SECURITY BARS**

DATE  
**2018-10-11**

SCALE  
**AS SHOWN**

DRAWN  
**VS**

CHECKED  
**GP**

PROJECT NO.  
**42/17**

DRAWING NO.

**AR3**