

--BRAKE ALL SHARP EDGES .010-.015
 -TOLERANCE DECIMAL +/- .005 +/- .0010
 -HARD COAT ANODIZE MIL-A-8625 TYPE III
 CLASS 2 , MATT BLACK .002 SURFACE
 -ALL TOLERANCE APPLY AFTER ANODIZE

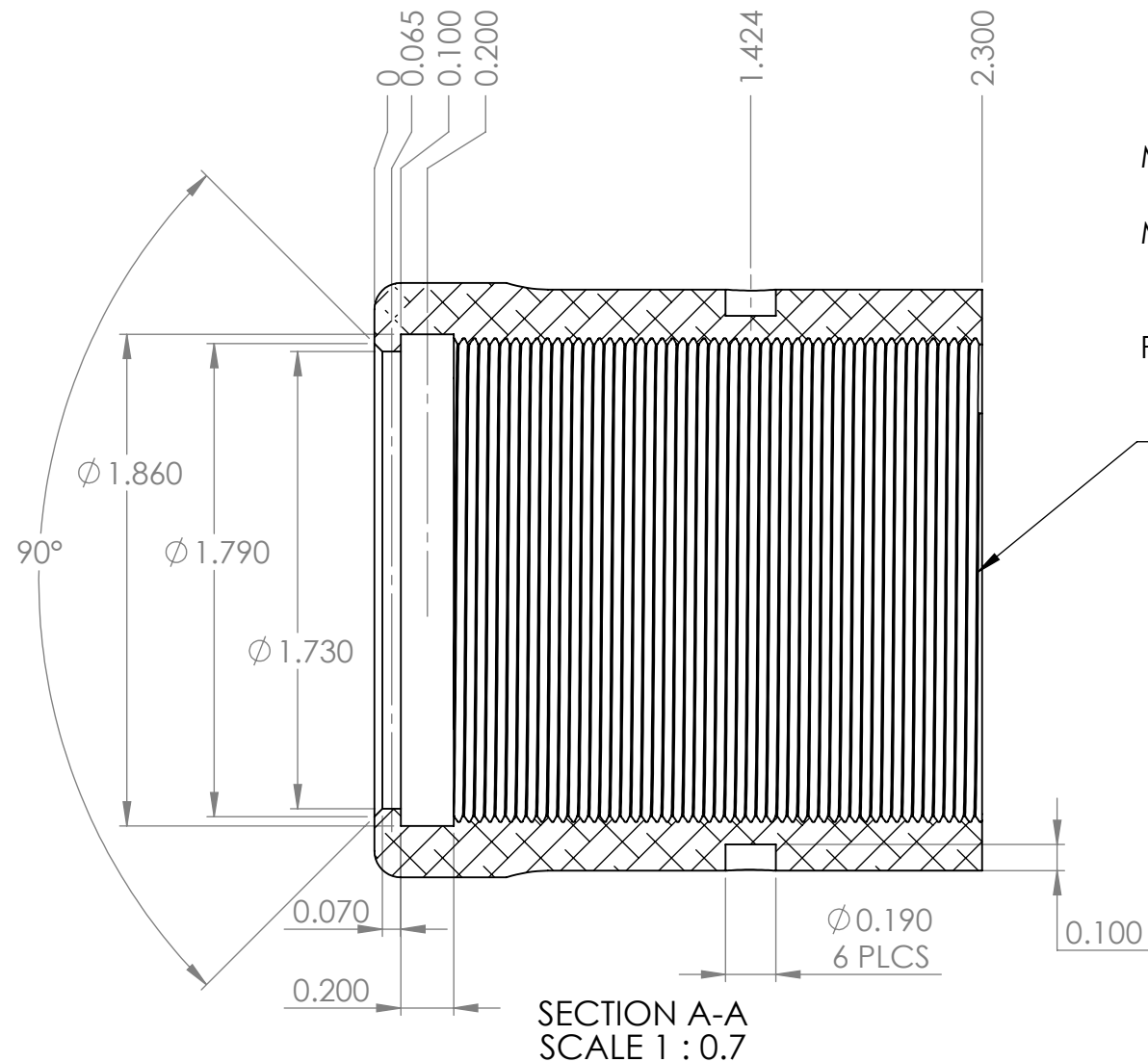
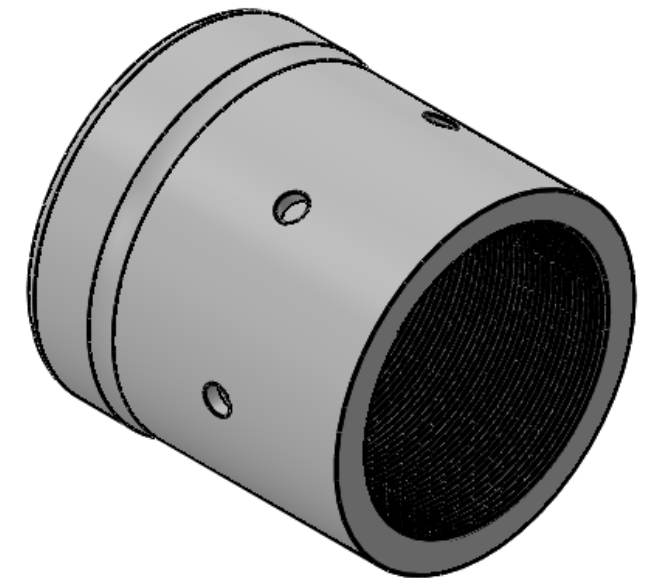

M46.5 X1 - 6H (TROUGH FIRST BRAKE)
 MAJOR DIAMETER MIN 46.526
 MINOR DIAMETER MIN 45.443
 MAX 45.679
 PITCH DIAMETER MIN 45.876
 MAX 46.051

SECTION A-A
 SCALE 1 : 0.7

UNLESS OTHERWISE SPECIFIED: DIMENSIONS ARE IN MILLIMETERS SURFACE FINISH: TOLERANCES: LINEAR: ANGULAR:			FINISH: CLEAN		DEBURR AND BREAK SHARP EDGES		DO NOT SCALE DRAWING		REVISION		
							RCMP-GRC				
							TITLE: MUZZLE PROTECTOR 40MM				
DRAWN			NAME		SIGNATURE		DATE		DWG NO. MUZZLE PROTECTOR 40MM		
CHK'D									A3		
APPV'D									SHEET 1 OF 1		
MFG											
Q.A							MATERIAL: 7075-T6				
							WEIGHT:		SCALE:1:1		